

CPF 20/80
PARTICULATE AIR FILTER
O. M. 04143

MC FILE NUMBER: 161-0278
DATE OF ISSUE: 06/30/78
REVISION: J, 12/2007

 **WARNING**

Do not proceed with these instructions until you have READ the orange cover of this MANUAL and YOU UNDERSTAND its contents. *

These WARNINGS are included for the health and safety of the operator and those in the immediate vicinity.

***If you are using a Clemco Distributor Maintenance and Part Guide, refer to the orange warnings insert preceding the Index before continuing with the enclosed instructions.**

Electronic files include a Preface containing the same important information as the orange cover.

© 2007 CLEMCO INDUSTRIES CORP.
One Cable Car Dr.
Washington, MO 63090
Phone (636) 239-4300
Fax (800) 726-7559
Email: info@clemcoindustries.com
www.clemcoindustries.com



⚠ WARNING

- Read and follow ALL instructions before using this equipment.
- Failure to comply with ALL instructions can result in serious injury or death.
- In the event that the user, or any assistants of the user of this equipment cannot read or cannot completely understand the warnings and information contained in these instructions, the employer of the user and his assistants must thoroughly educate and train them on the proper operation and safety procedures of this equipment.

NOTICE TO PURCHASERS AND USERS OF OUR PRODUCTS AND THIS INFORMATIONAL MATERIAL

The products described in this material, and the information relating to those products, is intended for knowledgeable, experienced users of abrasive blasting equipment.

No representation is intended or made as to the suitability of the products described herein for any particular purpose or application. No representations are intended or made as to the efficiency, production rate, or the useful life of the products described herein. Any estimate regarding production rates or production finishes are the responsibility of the user and must be derived solely from the user's experience and expertise, and must not be based on information in this material.

The products described in this material may be combined by the user in a variety of ways for purposes determined solely by the user. No representations are intended or made as to the suitability or engineering balance of the combination of products determined by the user in his selection, nor as to the compliance with regulations or standard practice of such combinations of components or products.

Abrasive Blast Equipment is only a component of the range of equipment used in an abrasive blasting job. Other products may include an air compressor, abrasive, scaffolding, hydraulic work platforms or booms, paint spray equipment, dehumidification equipment, air filters and receivers, lights, ventilation equipment, parts handling equipment, specialized respirators, or equipment that while offered by Clemco may have been supplied by others. Each manufacturer and supplier of the other products used in the abrasive blasting job must be contacted for information, training, instruction and warnings with regard to the proper and safe use of their equipment in the particular application for which the equipment is being used. The information provided by Clemco is intended to provide instruction only on Clemco products. All operators must be trained in the proper, safe, use of this equipment. It is the responsibility of the users to familiarize themselves with, and comply with, all appropriate laws, regulations, and safe practices that apply to the use of these products. Consult with your employer about training programs and materials that are available.

Our company is proud to provide a variety of products to the abrasive blasting industry, and we have confidence that the professionals in our industry will utilize their knowledge and expertise in the safe efficient use of these products.

GENERAL INSTRUCTIONS

Described herein are some, BUT NOT ALL, of the major requirements for safe and productive use of blast machines, remote control systems, operator respirator assemblies, and related accessories. Completely read ALL instruction manuals prior to using equipment.

The user's work environment may include certain HAZARDS related to the abrasive blasting operation. Proper protection for the blaster, as well as anyone else that may be EXPOSED to the hazards generated by the blasting process, is the responsibility of the user and/or the employer. Operators MUST consult with their employer about what hazards may be present in the work environment including, but not limited to, exposure to dust that may contain TOXIC MATERIALS due to the presence of silica, cyanide, arsenic or other toxins in the abrasive, or materials present in the surface to be blasted such as lead or heavy metals in coatings. The environment may also include fumes that may be present from adjacent coatings application, contaminated water, engine exhaust, chemicals, and asbestos. The work area may include PHYSICAL HAZARDS such as an uneven work surface, poor visibility, excess noise, and electrical hazards. The operator MUST consult with his employer on the identification of potential hazards, and the appropriate measures that MUST be taken to protect the blaster and others that might be exposed to these hazards.

ALL machines, components and accessories MUST be installed, tested, operated and maintained only by trained, knowledgeable, experienced users.

DO NOT modify or substitute any Clemco parts with other types or brands of equipment. Unauthorized modification and parts substitution on supplied air respirators is a violation of OSHA regulations and voids the NIOSH approval.

OPERATIONAL INSTRUCTIONS

OPERATOR SAFETY EQUIPMENT

⚠ WARNING

- Blast operators and others working in the vicinity of abrasive blasting must always wear properly-maintained, NIOSH-approved, respiratory protection appropriate for the job site hazards.
- DO NOT USE abrasives containing more than one percent crystalline (free) silica. Ref. NIOSH Alert #92-102
- Inhalation of toxic dust (crystalline silica, asbestos, lead paint and other toxins) can lead to serious or fatal disease (silicosis, asbestosis, lead or other poisoning).

- ALWAYS wear NIOSH-approved supplied-air respirators as required by OSHA, in the presence of any dust including, but not limited to, handling or loading abrasive; blasting or working in the vicinity of blast jobs; and cleanup of expended abrasive. Prior to removing respirator, an air monitoring

instrument should be used to determine when surrounding atmosphere is clear of dust and safe to breathe.

- NIOSH-approved, supplied-air respirators are to be worn ONLY in atmospheres:
 - NOT IMMEDIATELY dangerous to life or health and,
 - from which a user can escape WITHOUT using the respirator.
- Clemco supplied-air respirators **DO NOT REMOVE OR PROTECT AGAINST CARBON MONOXIDE (CO) OR ANY OTHER TOXIC GAS.** Carbon monoxide and toxic gas removal and/or monitoring device must be used in conjunction with respirator to insure safe breathing air.
- Air supplied to respirator **MUST BE AT LEAST GRADE D QUALITY** as described in Compressed Gas Association Commodity Specification G-7.1, and as specified by OSHA Regulation 1910.139 (d).
- ALWAYS locate compressors to prevent contaminated air (such as CO from engine exhaust) from entering the air intake system. A suitable in-line air purifying sorbent bed and filter or CO Monitor should be installed to assure breathing air quality.
- ALWAYS use a NIOSH-approved breathing air hose to connect an appropriate air filter to the respirator. Use of a non-approved air hose can subject the operator to illness caused by the release of chemical agents used in the manufacture of non-approved breathing air hose.
- ALWAYS check to make sure air filter and respirator system hoses are NOT CONNECTED to in-plant lines that contain nitrogen, acetylene or any other non-breathable gas. NEVER use oxygen with air line respirators. NEVER modify air line connections to accommodate air filter/respirator breathing hose WITHOUT FIRST testing content of the air line. **FAILURE TO TEST THE AIR LINE MAY RESULT IN DEATH TO THE RESPIRATOR USER.**
- Respirator lenses are designed to protect against rebounding abrasive. They do not protect against flying objects, glare, liquids, radiation or high speed heavy materials. Substitute lenses from sources other than the original respirator manufacturer will void NIOSH-approval of this respirator.

BLAST MACHINES AND REMOTE CONTROLS

 WARNING
<ul style="list-style-type: none"> • ALWAYS equip abrasive blast machines with remote controls. • Abrasive blast machine operators must wear NIOSH-approved supplied-air respirators (ref: OSHA regulations 1910.94, 1910.132, 1910.139 and 1910.244).

- NEVER modify OR substitute remote control parts. Parts from different manufacturers are NOT compatible with Clemco

equipment. If controls are altered, involuntary activation, which may cause serious injury, can occur.

- Inspect the air control orifice DAILY for cleanliness. NEVER use welding hose in place of twinline control hose. The internal diameter and rubber composition are UNSAFE for remote control use.
- UNLESS OTHERWISE SPECIFIED, maximum working pressure of blast machines and related components MUST NOT exceed National Board approved 125 psig (8.5 BAR).
- NEVER weld on blast machine. Welding may affect dimensional integrity of steel wall and WILL VOID National Board approval.
- Point nozzle ONLY at structure being blasted. High velocity abrasive particles WILL inflict serious injury. Keep unprotected workers OUT of blast area.
- NEVER attempt to manually move blast machine when it contains abrasive. EMPTY machines, up to 6 cu. ft.(270kg) capacity, are designed to be moved:
 - on flat, smooth surfaces by AT LEAST two people;
 - with the Clemco "Mule"; or
 - with other specially designed machine moving devices.
- Larger empty blast machines or ANY blast machine containing abrasive MUST be transported by mechanical lifting equipment.

AIR HOSE, BLAST HOSE, COUPLINGS, AND NOZZLE HOLDERS

- Air hose, air hose fittings and connectors at compressors and blast machines MUST be FOUR times the size of the nozzle orifice. Air hose lengths MUST be kept as short as possible AND in a straight line. Inspect DAILY and repair leakage IMMEDIATELY.
- Blast hose inside diameter MUST be THREE to FOUR times the size of the nozzle orifice. AVOID sharp bends that wear out hose rapidly. Use SHORTEST hose lengths possible to reduce pressure loss. Check blast hose DAILY for soft spots. Repair or replace IMMEDIATELY.
- ALWAYS cut loose hose ends square when installing hose couplings and nozzle holders to allow uniform fit of hose to coupling shoulder. NEVER install couplings or nozzle holders that DO NOT provide a TIGHT fit on hose. ALWAYS use manufacturers recommended coupling screws.
- Replace coupling gaskets FREQUENTLY to prevent leakage. Abrasive leakage can result in dangerous coupling failure. ALL gaskets MUST be checked SEVERAL times during a working day for wear, distortion and softness.
- Install safety pins at EVERY coupling connection to prevent accidental disengagement during hose movement.
- ALWAYS attach safety cables at ALL air hose AND blast hose coupling connections. Cables relieve tension on hose and control whipping action in the event of a coupling blow-out.

MAINTENANCE

- ALWAYS shut off compressor and depressurize blast machine BEFORE doing ANY maintenance.
- Always check and clean ALL filters, screens and alarm systems when doing any maintenance.
- ALWAYS cage springs BEFORE disassembling valves IF spring-loaded abrasive control valves are used.
- ALWAYS completely follow owner's manual instructions and maintain equipment at RECOMMENDED intervals.

ADDITIONAL ASSISTANCE

- Training and Educational Programs. Clemco Industries Corp. offers a booklet, Blast-Off 2, developed to educate personnel on abrasive blast equipment function and surface preparation techniques. Readers will learn safe and productive use of machines, components and various accessories, including selection of abrasive materials for specific surface profiles and degrees of cleanliness.
- The Society for Protective Coatings (SSPC) offers a video training series on protective coatings including one entitled "Surface Preparation." For loan or purchase information, contact SSPC at the address shown below.

TECHNICAL DATA AND RESEARCH COMMITTEES

- The following associations offer information, materials and videos relating to abrasive blasting and safe operating practices.

The Society for Protective Coatings (SSPC)
 40 24th Street, Pittsburgh PA 15222-4643
 Phone: (412) 281-2331 • FAX (412) 281-9992
 Email: research@sspc.org • Website: www.sspc.org

National Association of Corrosion Engineers (NACE)
 1440 South Creek Drive, Houston TX 77084
 Phone: (281) 228-6200 • FAX (281) 228-6300
 Email: msd@mail.nace.org • Website: www.nace.org

American Society for Testing and Materials (ASTM)
 100 Barr Harbor Dr., West Conshohocken, PA 19428
 Phone (610) 832-9500 • FAX (610) 832-9555
 Email: service@astm.org • Website: www.astm.org

NOTICE

This equipment is not intended to be used in an area that might be considered a hazardous location as described in the National Electric Code NFPA 70 1996, article 500.

WARRANTY

The following is in lieu of all warranties express, implied or statutory and in no event shall seller or its agents, successors, nominees or assignees, or either, be liable for special or consequential damage arising out of a breach of warranty. This warranty does not apply to any damage or defect resulting from negligent or improper assembly or use of any item by the buyer or its agent or from alteration or attempted repair by any person other than an authorized agent of seller. All used, repaired, modified or altered items are purchased "as is" and with all faults. In no event shall seller be liable for consequential or incidental damages. The sole and exclusive remedy of buyer for breach of warranty by seller shall be repair or replacement of defective parts or, at seller's option, refund

- of the purchase price, as set forth below:
1. Seller makes no warranty with respect to products used other than in accordance hereunder.
 2. On products seller manufactures, seller warrants that all products are to be free from defects in workmanship and materials for a period of one year from date of shipment to buyer, but no warranty is made that the products are fit for a particular purpose.
 3. On products which seller buys and resells pursuant to this order, seller warrants that the products shall carry the then standard warranties of the manufacturers thereof, a copy of which shall be made available to customer upon request.
 4. The use of any sample or model in connection with this order is for illustrative purposes only and is not to be construed as a warranty that the product will conform to the sample or model.
 5. Seller makes no warranty that the products are delivered free of the rightful claim of any third party by way of patent infringement or the like.
 6. This warranty is conditioned upon seller's receipt within ten (10) days after a buyer's discovery of a defect, of a written notice stating in what specific material respects the product failed to meet this warranty. If such notice is timely given, seller will, at its option, either modify the product or part to correct the defect, replace the product or part with complying products or parts, or refund the amount paid for the defective product, any one of which will constitute the sole liability of seller and a full settlement of all claims. No allowance will be made for alterations or repairs made by other than those authorized by seller without the prior written consent of seller. Buyer shall afford seller prompt and reasonable opportunity to inspect the products for which any claim is made as above stated.

Except as expressly set forth above, all warranties, express, implied or statutory, including implied warranty of merchantability, are hereby disclaimed.

DAILY SET-UP CHECK LIST

 WARNING
<ul style="list-style-type: none"> • ALL piping, fittings and hoses MUST be checked DAILY for tightness and leakage. • ALL equipment and components MUST be thoroughly checked for wear. • ALL worn or suspicious parts MUST be replaced. • ALL blast operators MUST be properly trained to operate equipment. • ALL blast operators MUST be properly outfitted with abrasive resistant clothing, safety shoes, leather gloves and ear protection. • BEFORE blasting ALWAYS use the following check list.

1. PROPERLY MAINTAINED AIR COMPRESSOR sized to provide sufficient volume (cfm) for nozzle and other tools PLUS a 50% reserve to allow for nozzle wear. Use large compressor outlet and large air hose (4 times the nozzle orifice size). FOLLOW MANUFACTURERS MAINTENANCE INSTRUCTIONS.

2. BREATHING AIR COMPRESSOR (oil-less air pump) capable of providing Grade D Quality air located in a dust free, contaminant free area. If oil-lubricated air compressor is used to supply respirator, it should have high temperature monitor and CO monitor or both. If CO monitor is not used, air **MUST** be tested FREQUENTLY to ensure proper air quality.

3. Clean, properly maintained NIOSH-APPROVED SUPPLIED-AIR RESPIRATOR. ALL components should ALWAYS be present. NEVER operate without inner lens in place. Thoroughly inspect ALL components DAILY for cleanliness and wear. ANY substitution of parts voids NIOSH approval i.e. cape, lenses, breathing hose, breathing air supply hose, air control valve, cool air or climate control devices.

4. OSHA required BREATHING AIR FILTER for removal of moisture and particulate matter from breathing air supply. THIS DEVICE DOES NOT REMOVE OR DETECT CARBON MONOXIDE (CO). ALWAYS USE CO MONITOR ALARM.

5. ASME CODED BLAST MACHINE sized to hold 1/2 hour abrasive supply. ALWAYS ground machine to eliminate static electricity hazard. Examine pop up valve for alignment. Blast machine MUST be fitted with a screen to keep out foreign objects and a cover to prevent entry of moisture overnight.

6. AIR LINE FILTER installed AS CLOSE AS POSSIBLE to machine inlet. Sized to match inlet piping or larger air supply line. Clean filter DAILY. Drain OFTEN.

7. REMOTE CONTROLS MUST be in PERFECT operating condition. ONLY use APPROVED spare parts, including twin-line hose. DAILY: test system operation and check button bumper and spring action of lever and lever lock. DO NOT USE WELDING HOSE.

8. BLAST HOSE with ID 3 to 4 times the nozzle orifice. Lines MUST be run AS STRAIGHT AS POSSIBLE from machine to work area with NO sharp bends. Check DAILY for internal wear and external damage.

9. HOSE COUPLINGS, NOZZLE HOLDERS fitted SNUGLY to hose end and installed using PROPER coupling screws. Coupling lugs MUST be snapped FIRMLY into locking position. Gasket MUST form positive seal with safety pins inserted through pin holes. Check gaskets and replace if ANY sign of wear, softness or distortion. ALWAYS install safety cables at every connection to prevent disengagement. Check nozzle holder for worn threads. NEVER MIX DIFFERENT BRANDS OF COMPONENTS. Check each of these components DAILY.

10. Inspect NOZZLE and GASKET DAILY for wear. Replace nozzle when 1/16" larger than original size or if liner appears cracked. Check nozzle threads for wear.

11. Use abrasive that is properly sized and free of harmful substances; such as, free silica, cyanide, arsenic or lead. Check material data sheet for presence of toxic or harmful substances.

12. Test surface to be blasted for toxic substances. Take appropriate, and NIOSH required, protective measures for operator and bystanders which pertain to substances found on the surface to be blasted.

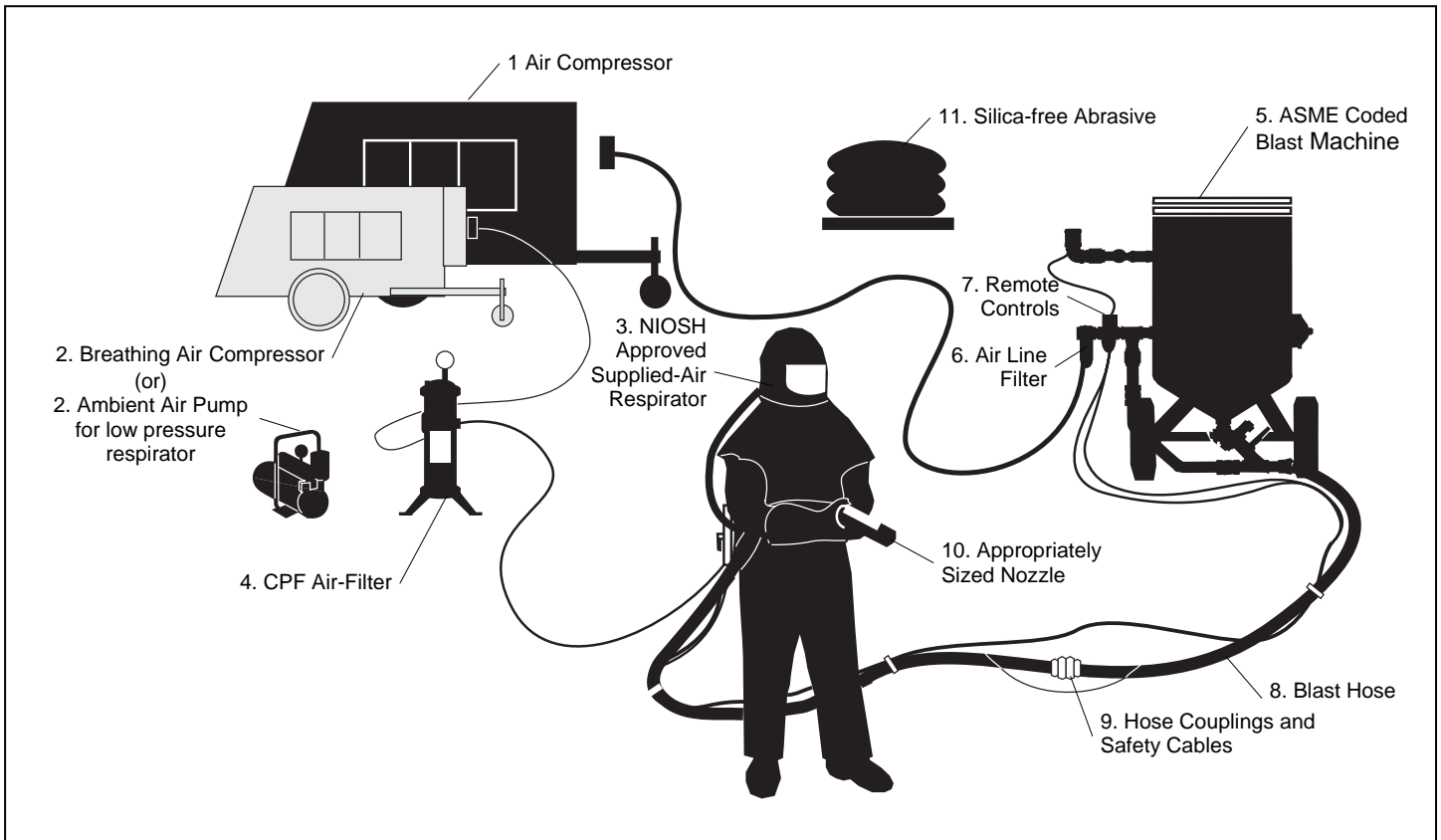

1.0 INTRODUCTION

1.1 Scope of Manual

1.1.1 These instructions cover setup, operation, maintenance, replacement parts, and important warnings to safely operate the Clemco CPF Particulate Air Filter.

1.1.2 These instructions also contain important information required for safe operation of the filter. All respirator users and maintenance personnel must be trained to safely operate and maintain the filter and respirators. The respirator users and all personnel involved with the breathing air process must be able to identify potential hazards associated with breathing compressed air. Before using the filter, all personnel involved with the operation must read this entire manual, including the orange cover, plus the respirator manuals and all accessory manuals.

1.2 Safety Alerts

1.2.1 Clemco uses safety alert signal words, based on ANSI Z535.4-1998, to alert the user of a potentially hazardous situation that may be encountered while operating this equipment. ANSI's definitions of the signal words are as follows:



This is the safety alert symbol. It is used to alert the user of this equipment of potential personal injury hazards.

Obey all safety messages that follow this symbol to avoid possible injury or death.

CAUTION

Caution used without the safety alert symbol indicates a potentially hazardous situation which, if not avoided, may result in property damage.

CAUTION

Caution indicates a potentially hazardous situation which, if not avoided, may result in minor or moderate injury.

WARNING

Warning indicates a potentially hazardous situation which, if not avoided, could result in death or serious injury.

DANGER

Danger indicates an imminently hazardous situation which, if not avoided, will result in death or serious injury.

1.3 OSHA Compliance

1.3.1 When CPF Filters are used with a NIOSH-approved supplied-air respirator, meets OSHA regulations 1910.94(a)(6) and 1910.134 (i)(5)(iii), requiring air for abrasive blasting respirators shall be free of harmful quantities of dust, mists, and noxious odors. CPF filters provide a pressure-reducing valve to lower the pressure to meet the pressure requirements of the respirator, providing that the filter's inlet pressure does not exceed 150 psi.

1.3.2 Important information concerning the quality of compressed air, the use of respirators, and exposure to hazardous dust is found in OSHA regulations 29 CFR 1910.94, 29 CFR 1910.134 and 29 CFR 1910.1000. Note regulations 29 CFR 1910.94 and 29CFR1910.134 require that abrasive blasting respirators meet the requirements for supplied-air quality. For total compliance, the system must also include a NIOSH-approved supplied-air respirator.

1.3.3 All supplied-air respirators using non-oil-lubricated or oil-lubricated compressors shall have a carbon monoxide monitor to meet the requirements of CFR 1910.134 (i)(6) and (i)(7).

1.3.4 OSHA regulations 29 CFR1910 and 29CFR1926 require that respirator air line couplers be incompatible with air lines for non-respirable use. This prevents inadvertent servicing of respirators with non-respirable gases or oxygen. It is the employer's or facility owner's responsibility to comply with the regulation.

1.3.5 The CPF filter is to be used with NIOSH-approved supplied-air respirators in atmospheres not immediately dangerous to life or health (IDLH), with at least 19.5% oxygen, and from which a user can escape without the use of the respirator.

1.3.6 Breathing air used to supply the filter must be respirable breathing air and contain no less than 19.5 volume-percent of oxygen. Breathing air shall also meet the requirements for Grade D or higher quality, as described in Compressed Gas Association Commodity Specification pamphlet G-7.1., titled Commodity Specification For Air, published by Compressed Gas Association Inc., Chantilly, VA. CGA Website is cganet.com

⚠ WARNING

Respirator(s) must be supplied with at least Grade "D" quality respirable air, containing no less than 19.5 volume-percent of oxygen. Breathing air requirements are described in Compressed Gas Association, G-7.1., Commodity Specification For Air, published by Compressed Gas Association Inc., Chantilly, VA. CGA Website is cganet.com. If air quality is unknown, consult a safety professional and/or industrial hygienist. Poor quality air will cause serious respiratory injury or death to the user.

1.4 General Description

1.4.1 The CPF is a particulate filter, which removes mists (including oil mist), water vapor and particulate matter, down to 0.5 micron in size from breathing air supplied by a breathing-air compressor. **The CPF Filter does not detect or remove carbon monoxide (CO) or any other toxic gases.** Filter effectiveness and cartridge life will be reduced considerably if the supplied air is heavily contaminated with particulate matter or moisture.

1.4.2 The main components of the filters are shown in Figure 1. The CPF-20 is equipped with an outlet that

supplies filtered air to one or two supplied-air respirators. The CPF-80 has four outlets, and will accommodate up to four supplied-air respirators with total air requirement not to exceed 100 cfm.

⚠ WARNING

Respirators are NIOSH-approved to operate within specific pressure ranges. When connecting multiple respirators, make sure that all respirators are approved to operate within the same pressure range. Operating the respirator outside of the approved pressure range will increase or restrict airflow beyond permissible limits.

1.4.3 Compressed air enters the filter through either of the two side inlet ports. Moisture condensing inside the filter is drained through the petcock at the bottom of the filter body. Air is forced through a replaceable filter cartridge, which contains several filtering materials, which traps particulates.

1.4.4 Outlet pressure is adjusted by the knob on the pressure regulator. Both filters are equipped with a pressure relief valve. The relief valve is an audible signal that pressure is exceedingly high.

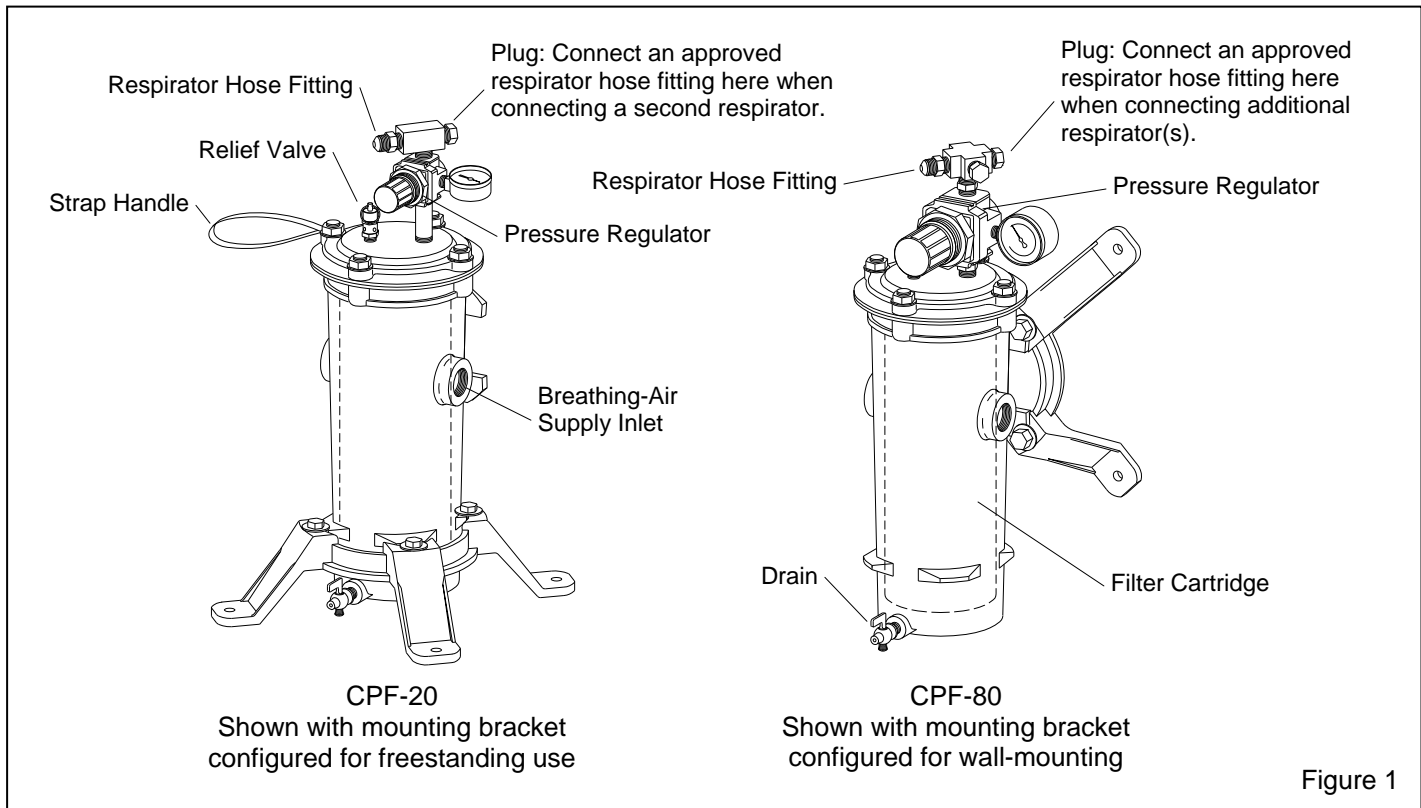

Figure 1

2.0 ASSEMBLY

2.1 Mounting Bracket

2.1.1 Refer to Figure 2 and attach the mounting bracket to the four bottom lugs for freestanding, floor use, or to the four side lugs for wall mounting.

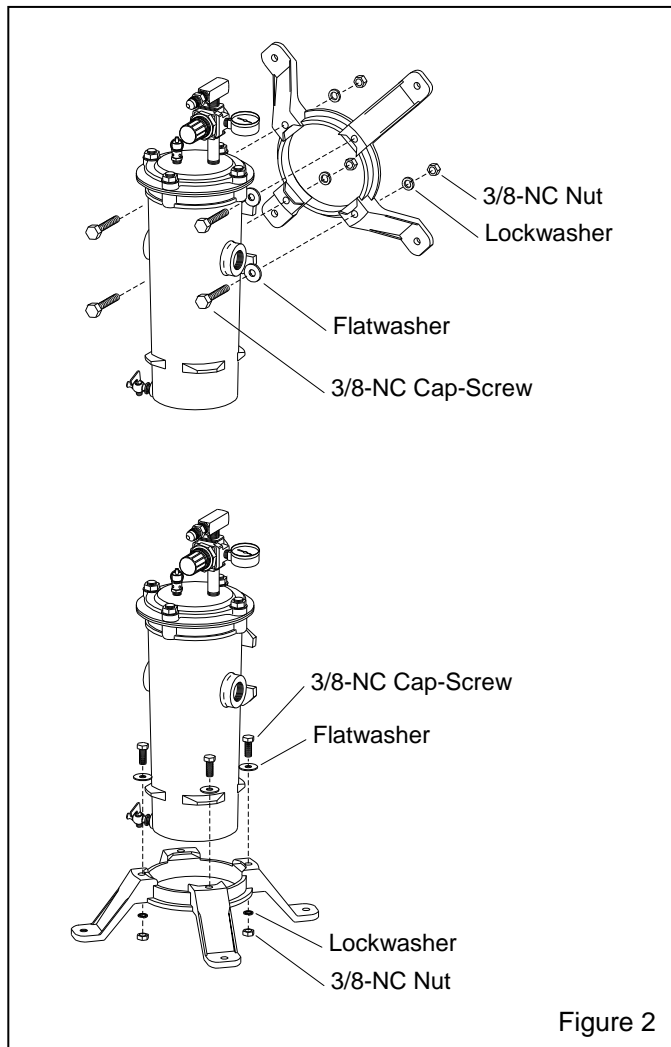

Figure 2

2.2 Regulator Assembly, Ref. Figure 3

NOTE: To ensure air tight seals, use Teflon tape on all male pipe threads. It is easiest to assemble the CPF regulator assembly, wrench tight in a vice, and then screw the assembly onto the cap.

2.2.1 Attach the male end of the 3/8" NPT tee, (cross manifold on CPF-80) to the pressure regulator outlet port (see direction of air-flow arrow on the regulator, the inlet is from the back of the arrow).

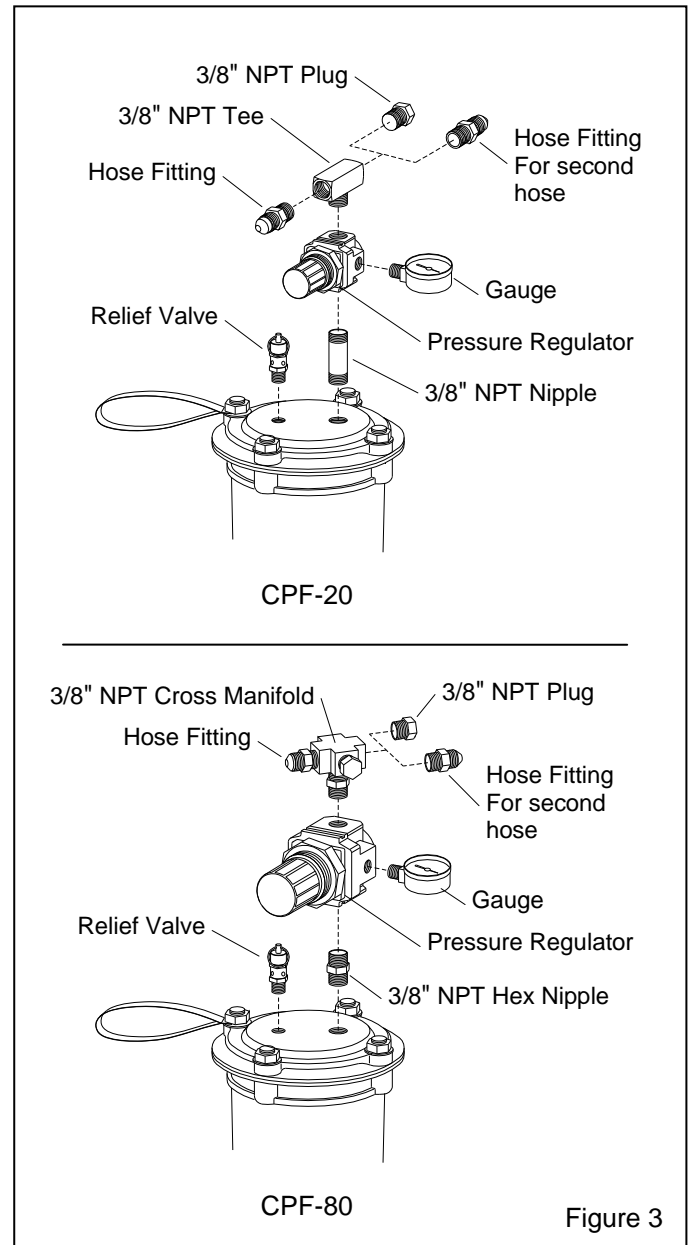

Figure 3

2.2.2 Attach a respirator hose fitting that is approved for use with the respirator (the fitting is supplied with the respirator hose), to one of the ports on the 3/8" branch tee (cross manifold on CPF-80). Plug the other port(s) when connecting a single respirator.

2.2.3 Multiple outlets: When supplying air to additional respirators, remove as many plugs as required and replace them with approved hose fittings, up to two on the CPF-20, up to four on the CPF-80. When multiple respirators are used with the CPF, they must all be approved to operate within the same pressure range.

⚠ WARNING

Outlet fittings (the point of attachment) and respirator hose must be NIOSH-approved for use with the respirator. Use of non-approved fittings and hose will void the NIOSH approval of the respirator, and could restrict air flow. Do not use any bushings or reducers that reduce the internal diameter of the plumbing. Reduced air flow may result in ingress of hazardous dust, fumes or gases, exposing the user to immediate health risk and subsequent respiratory disease and possible death.

2.2.4 Attach the 3/8" x 2" nipple (3/8" hex nipple on CPF-80) to the regulator inlet port, and tighten the regulator assembly into the 3/8" port on the filter cap. Arrange the assembly so the outlet ports of the tee are accessible, and the regulator control knob is convenient to adjust.

2.2.5 Screw the pressure gauge into one of the regulator side ports, and position it so the pressure can be easily monitored.

2.2.6 Screw the relief valve into the remaining port on the cap.

3.0 AIR SUPPLY**⚠ WARNING**

Air supply to this filter is critical to the safety of the user. Read this section and the respirator manuals carefully. Poor quality air will cause serious respiratory injury or death to the user. (See Toxic Dust Poisoning Warning on page 1.)

3.1 Air Quality

3.1.2 Air supplied to the filter's inlet must be at least Grade "D" quality. Special care must also be taken to avoid accidental connection to any other gas lines, such as, oxygen, acetylene, or nitrogen.

⚠ DANGER

CPF Filters are particulate filters. They do not remove carbon monoxide or other toxic gases. Air supplied to the filter inlet must be at least Grade "D" quality. Never connect the CPF Filter or any breathing-air line to an air source that has not been tested for gas contamination. The presence of unacceptable levels of carbon monoxide (CO) or other gases, or oxygen deficiency in the breathing air will cause death to the user.

⚠ WARNING

OSHA regulations 29 CFR 1910 and 29 CFR 1926 require that respirator air line couplers be incompatible with air lines for non-respirable use. This incompatibility prevents inadvertent supply of respirators with potentially hazardous, non-respirable gases, or oxygen. It is the employer's or facility owner's responsibility to comply with the regulations.

3.1.3 Prior to using the filter and respirator, read the owner's manual and all instructions, labels, and warnings related to the compressed air source. Take special care to abide by all warnings from the compressor manufacturer regarding compressor use.

3.1.4 A breathing-air-type-compressor must be used. The compressor must be equipped with necessary safety and monitoring devices, plus suitable in-line air filters and purifying equipment to assure breathing-air quality. [Reference OSHA Regulation 1910.134 (d)].

3.1.5 If an oil-lubricated compressor is used, it must be equipped with a high-temperature alarm or carbon monoxide (CO) alarm, or both. If only a high-temperature alarm is used, the air from the compressor must be tested frequently for the presence of carbon monoxide. [Reference OSHA Regulation 1910.134 (d)].

3.1.6 Regardless of the air compressor type, precautions must be taken to prevent contaminants from entering through the compressor intake. The compressor inlet must be located away from all sources of toxic contaminants including carbon monoxide, which is found in engine exhaust, and in any form of combustion. No vehicles should be allowed near the compressor intake. Contaminants can enter respiratory equipment through the compressor air inlet. This inlet must not be located near any exhaust system outlet, ventilation flue, or source of fumes or particles of any kind.

3.1.7 The preceding precautions also apply to portable compressors. In addition, in the case of engine-driven compressors, precautions must be taken to prevent engine exhaust gases from entering the air intake of the compressor. Compressor engine exhaust should be piped to a location safely downwind from the compressor air intake. Compressors vary in design and operation; therefore, it is important that users carefully read the manufacturer's operation and maintenance instructions before making modifications.

3.1.8 It is the owner's and user's responsibility to make sure the air supply is safe to breathe. The air supply includes the compressor, carbon monoxide alarms, and shutdown devices. An overheated compressor, or one that is in poor mechanical condition, may produce carbon monoxide. A carbon monoxide removal or conversion system may also be used to ensure breathing-air quality. The maximum allowable level of carbon monoxide in Grade D breathing air is 10 ppm (parts per million).

3.2 Air Pressure (Outlet Pressure)

3.2.1 Outlet pressure must be set to the pressure for which the respirator(s) is designed. Refer to the respirator owner's manual to find the approved pressure setting. All respirators connected to the filter must be approved to operate within the same pressure range.

WARNING

Failure to maintain the minimum pressure at the CPF filter outlet (point of attachment) may reduce air flow below the minimum flow required by OSHA. Reduced air flow may result in ingress of hazardous toxic dust, subjecting the user to immediate health and life threatening poisoning and subsequent respiratory disease.

4.0 SETUP

NOTE: The filter must be setup and placed in an area that permits monitoring of the outlet pressure, access to the drain, and removal of the cap for filter cartridge replacement.

4.1 Breathing-Air Connections

4.1.1 Filters can be configured for either left or right hand inlet. If it is more convenient to have the air inlet on the opposite side, swap the plug and inlet connector. This is usually required only with fixed installations.

4.1.2 The following instructions explain air connections using hose as the air supply line; hard piping may be used in place of hose. If the filter is hard-piped, place an isolation valve in the piping to enable depressurization for service.

4.1.3 Connect an air fitting that is compatible with the air supply hose, from an air source that meets OSHA requirements for respirable air, to either of the inlet ports on the side of the filter. The port's thread size is 1" NPT.

4.1.4 Connect a 3/4" ID or larger air hose, from a respirable air source to the inlet fitting. Maximum inlet pressure is 150 psi.

DANGER

Do not connect the CPF Filter to bottled air or any other air source that does not have a pressure-reducing valve that lowers pressure to maximum of 150 psi. Failure to comply with this warning will cause the CPF filter to explode under the high pressure of bottled air, and could cause severe injury or death.

5.0 ADJUSTMENTS

5.1 Outlet Pressure

5.1.1 Outlet pressure must be set to the pressure for which the respirator(s) is approved. The respirator's approved pressure may be found in the respirator's owner's manual. All respirators connected to a filter must be approved to operate within the same pressure range.

5.1.2 Adjust pressure with respirators attached and prior to donning the respirator.

5.1.3 To adjust pressure: pull the regulator knob out, and turn clockwise to increase pressure or counter-clockwise to decrease. Pressure will register on the gauge. Once operating pressure is set, push the knob in to lock.

6.0 MAINTENANCE

6.1 Draining

6.1.1 Drain moisture from the filter every four hours. More frequent draining may be required in humid environments. The drain petcock is located on the bottom of the filter body.

6.2 Filter Cartridge Replacement

6.2.1 Never attempt to clean the filter cartridge. Replace the filter cartridge at least every three months. Replace it sooner if:

- Users detect any objectionable odors.
- The filter begins to pass moisture through the outlets.
- The outlet pressure nears the lowest pressure for which the respirators are approved.

6.2.2 Before replacing the cartridge, always drain the filter through the petcock and leave the drain open. Shut off the compressed air supply to the filter. Make sure petcock no longer exhausts air and that the pressure gauge reads zero.

6.2.3 Remove the four nuts that hold cap in place and lift the cap. Install the new cartridge with the arrow pointing up. Inspect the cap gasket and o-ring and replace them as needed.

6.3 Cartridge Replacement Record

6.3.1 Use the chart in Figure 4 to maintain an accurate record of filter cartridge replacement dates. Replace the filter cartridge at least every three months with a genuine Clemco replacement filter cartridge.

Filter Cartridge Replacement Record	
Date originally Installed:	
Replacement Due Date	Date of Replacement

Figure 4

7.0 REPLACEMENT PARTS

Item	Description	Stock No.
(-)	CPF-80 air filter assembly	03527
(-)	CPF-20 air filter assembly	03578

7.1 Common Parts, Figure 5

Item	Description	Stock No.
1.	Cartridge, CPF filter	03547
2.	Cap screw, 3/8-NC x 1" hex head	03252
3.	Washer, 1-1/4" OD	03310
4.	Nut, 3/8-NC	03311
5.	Petcock, 1/4"	01993
6.	Mounting bracket	03557
7.	Plug, 1" NPT	03532
8.	Washer, 1/2" SAE flat	03515
9.	Nut, 1/2-NC	03511
10.	Gasket, filter top	03559
11.	Washer, 3/8" lock	03318
12.	Stud, 1/2-NC x 2"	03545
13.	Handle strap	03623
14.	O-ring, cap	03561

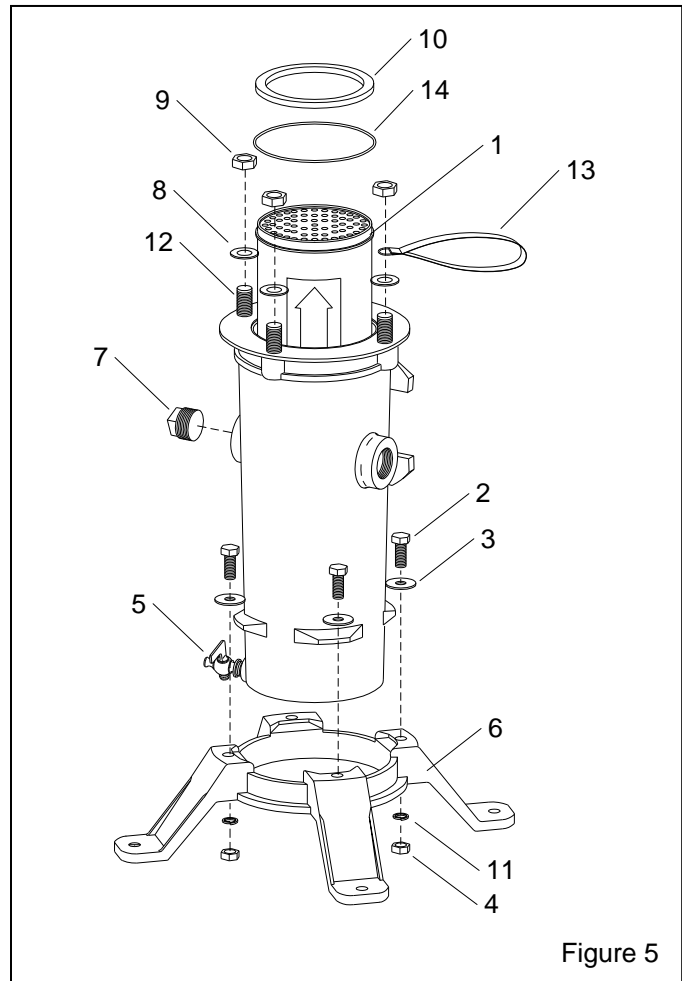

Figure 5

7.2 CPF-20 Cap, Figure 6

Item	Description	Stock No.
1.	Pressure gauge	00024
* 2.	Tee, 3/8" NPT male branch	22843
* 3.	Nipple, 3/8" NPT x 2" brass	03720
4.	Relief valve, 1/4" NPT	01909
* 5.	Pressure regulator, less gauge 3/8" NPT small body.....	03594
6.	Cap, CPF filter	03584
* 7.	Plug, 3/8" NPT brass	03536
(-)	Regulator kit, converts old style regulator to new style, includes items marked * ...	03582

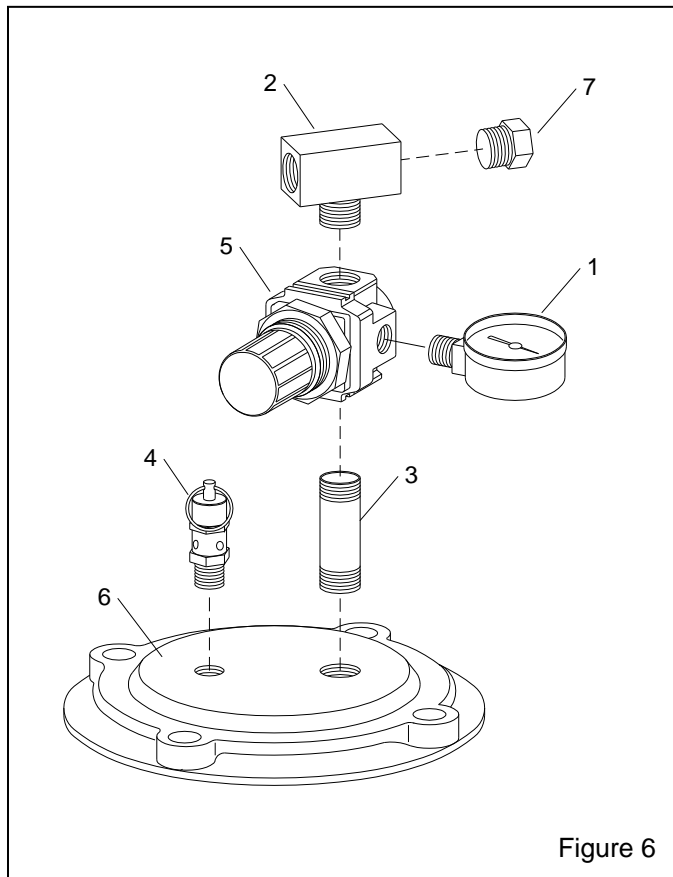

Figure 6

7.3 CPF-80 Cap, Figure 7

Item	Description	Stock No.
1.	Pressure gauge	00024
* 2.	Cross manifold, 3/8" NPT	22941
* 3.	Nipple, 3/8" NPT hex	03596
4.	Relief valve, 1/4" NPT	01909
* 5.	Pressure regulator, less gauge 3/8" NPT large body.....	22939
6.	Cap, CPF filter	03584
* 7.	Plug, 3/8" NPT brass	03536
(-)	Regulator kit, converts CPF-20 to CPF-80 includes items marked *	22937
(-)	Conversion kit, converts old style CPF-80 to new style. Includes items marked*, plus cap, cap o-ring, and handle strap. The kit does not include the relief valve item (4) or gauge item (1) Order separately if needed.....	23477

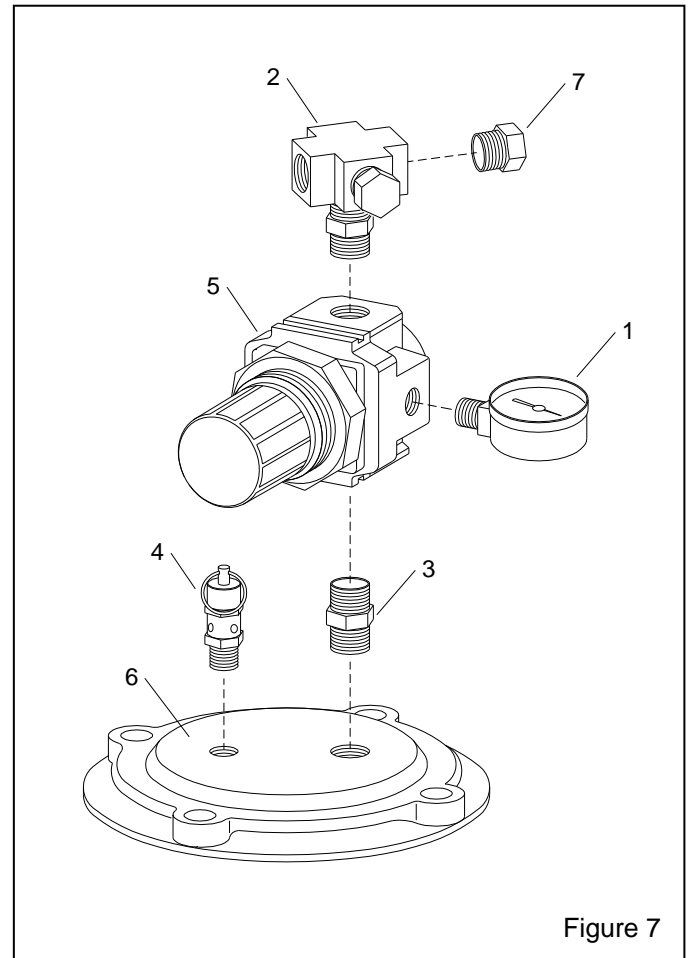

Figure 7