

01 Nov 2009

Husqvarna X390

Illustrated Parts List

574 64 94-11

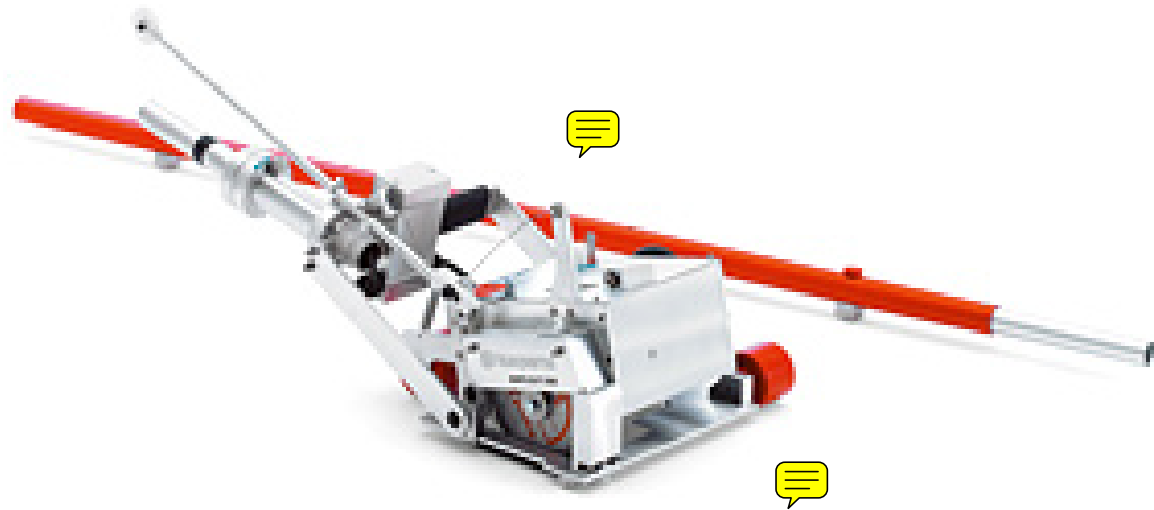

#505583001 - Starter Plate
(guide to start the cut through the form)

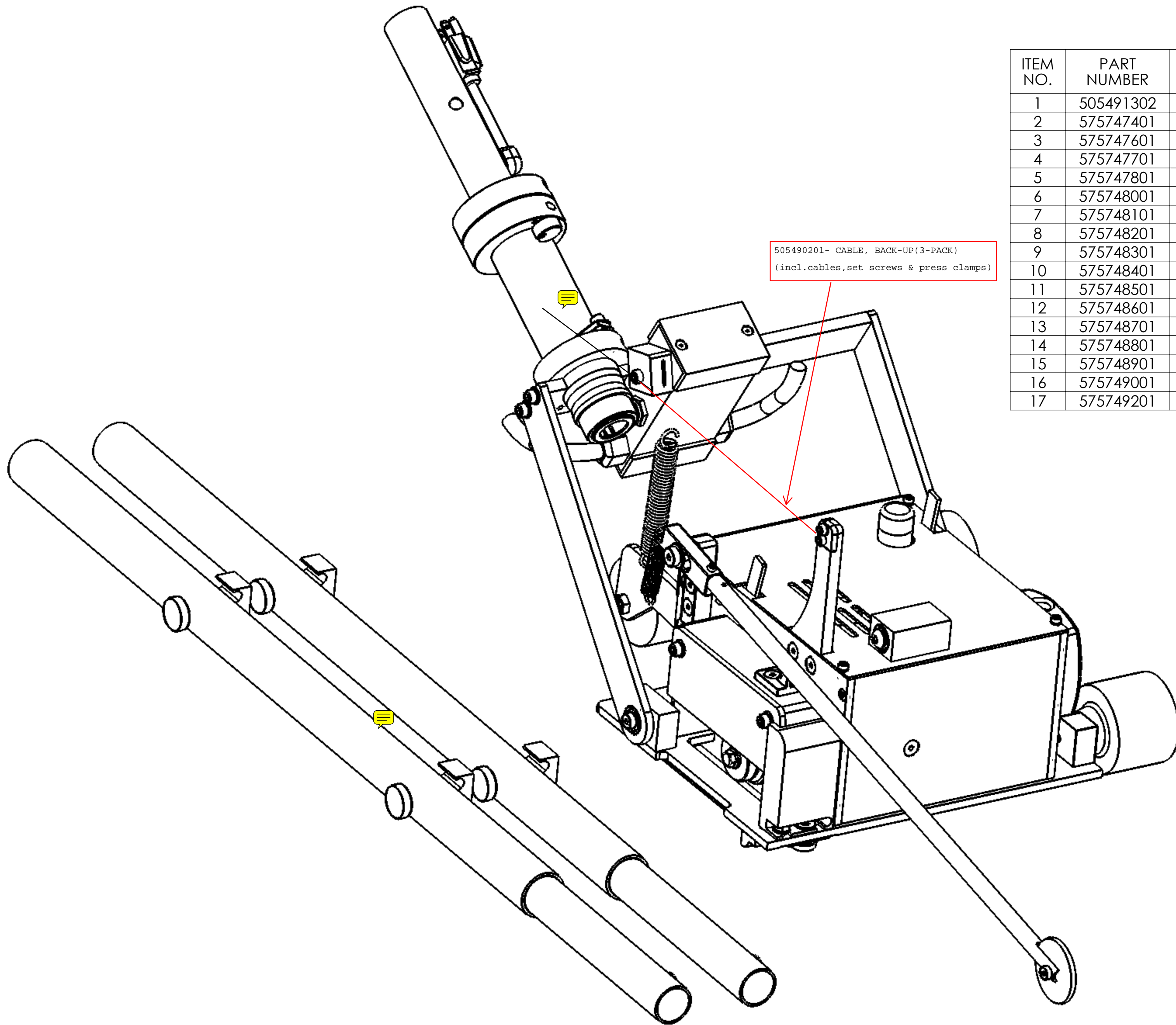

ITEM NO.	PART NUMBER	DESCRIPTION	QTY.
1	505491302	KIIT, HANDLE POLE, FRONT	2
2	575747401	BOTTOM PLATE ASSEMBLY	1
3	575747601	FRONT WHEEL ASSEMBLY	1
4	575747701	REAR WHEEL ASSEMBLY	1
5	575747801	MOTOR BOX ASSEMBLY	1
6	575748001	BACK-UP WHEEL ASSEMBLY	1
7	575748101	PENDULUM ASSEMBLY	1
8	575748201	BLADE SHROUD ASSEMBLY	1
9	575748301	PRESSURE BLOCK ASSEMBLY	1
10	575748401	ARBOR LOCK LEVER ASSEMBLY	1
11	575748501	CABLE MOUNTING BLOCK ASSEMBLY	1
12	575748601	BOX RELEASE LEVER ASSEMBLY	1
13	575748701	HANDLE BRACKET ASSEMBLY	1
14	575748801	HANDLE TUBE ASSEMBLY	1
15	575748901	SWITCH TUBE ASSEMBLY	1
16	575749001	GUIDE ARM ASSEMBLY	1
17	575749201	TOP COVER ASSEMBLY	1

SUB-ASSEMBLY BILL OF MATERIAL

SOFF-CUT INTL. INC. CLAIMS PROPRIETARY RIGHTS TO THE MATERIAL DISCLOSED IN THIS DOCUMENT. THIS DOCUMENT IS PROVIDED IN CONFIDENCE AND MAY NOT BE REPRODUCED OR DISCLOSED WITHOUT WRITTEN PERMISSION FROM SOFF-CUT INTL. © COPYRIGHT 2005, SOFF-CUT INTL. INC. ALL RIGHTS RESERVED.

~~575749101~~
505859501

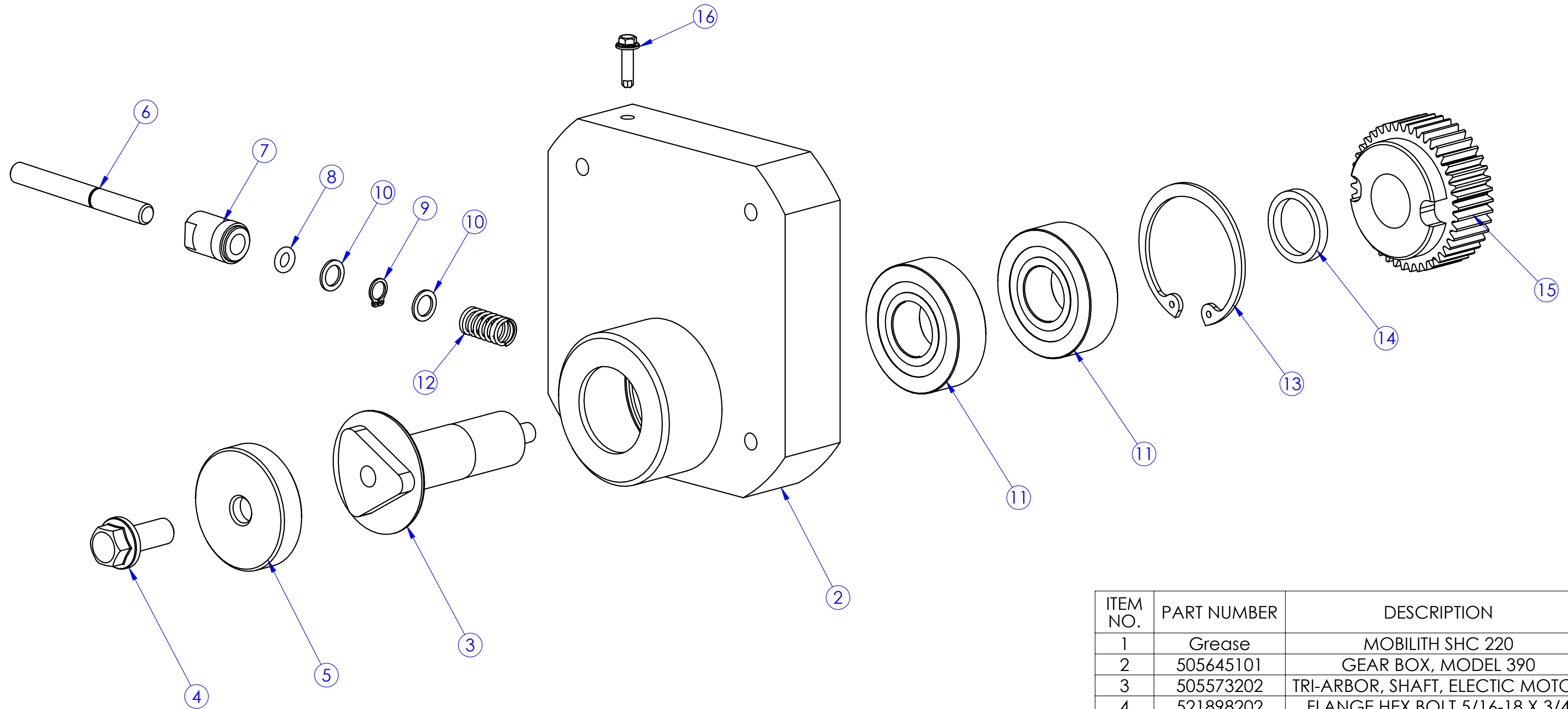

ITEM NO.	PART NUMBER	DESCRIPTION	QTY.
1	Grease	MOBILITH SHC 220	1
2	505645101	GEAR BOX, MODEL 390	1
3	505573202	TRI-ARBOR, SHAFT, ELECTIC MOTOR	1
4	521898202	FLANGE HEX BOLT 5/16-18 X 3/4	1
5	505491501	WASHER, OUTER ARBOR	1
6	505645201	SHAFT, ARBOR LOCK	1
7	505645401	FITTING, ARBOR LOCK	1
8	505646001	O-RING 3/16 ID X .070 THK	1
9	505646201	SNAP RING, EXT .250"	1
10	505646401	WASHER, LOCK BUTTON	2
11	505646501	BEARING, 6203	2
12	505646801	SPRING, LOCK BUTTON	1
13	505645901	SNAP RING, INT 40mm	1
14	505645501	SPACER, X390	1
15	505646601	GEAR, MAIN	1
16	505634901	SCREW, TEKS, #8 X 1/2 HEX S.S.	1

SUB-ASSEMBLY BILL OF MATERIAL

SOFF-CUT INT'L, INC. CLAIMS PROPRIETARY RIGHTS TO THE MATERIAL DISCLOSED IN THIS DOCUMENT. THIS DOCUMENT IS PROVIDED IN CONFIDENCE AND MAY NOT BE REPRODUCED OR DISCLOSED WITHOUT WRITTEN PERMISSION FROM SOFF-CUT INT'L. © COPYRIGHT 2007, SOFF-CUT INT'L, INC. ALL RIGHTS RESERVED.

575747901

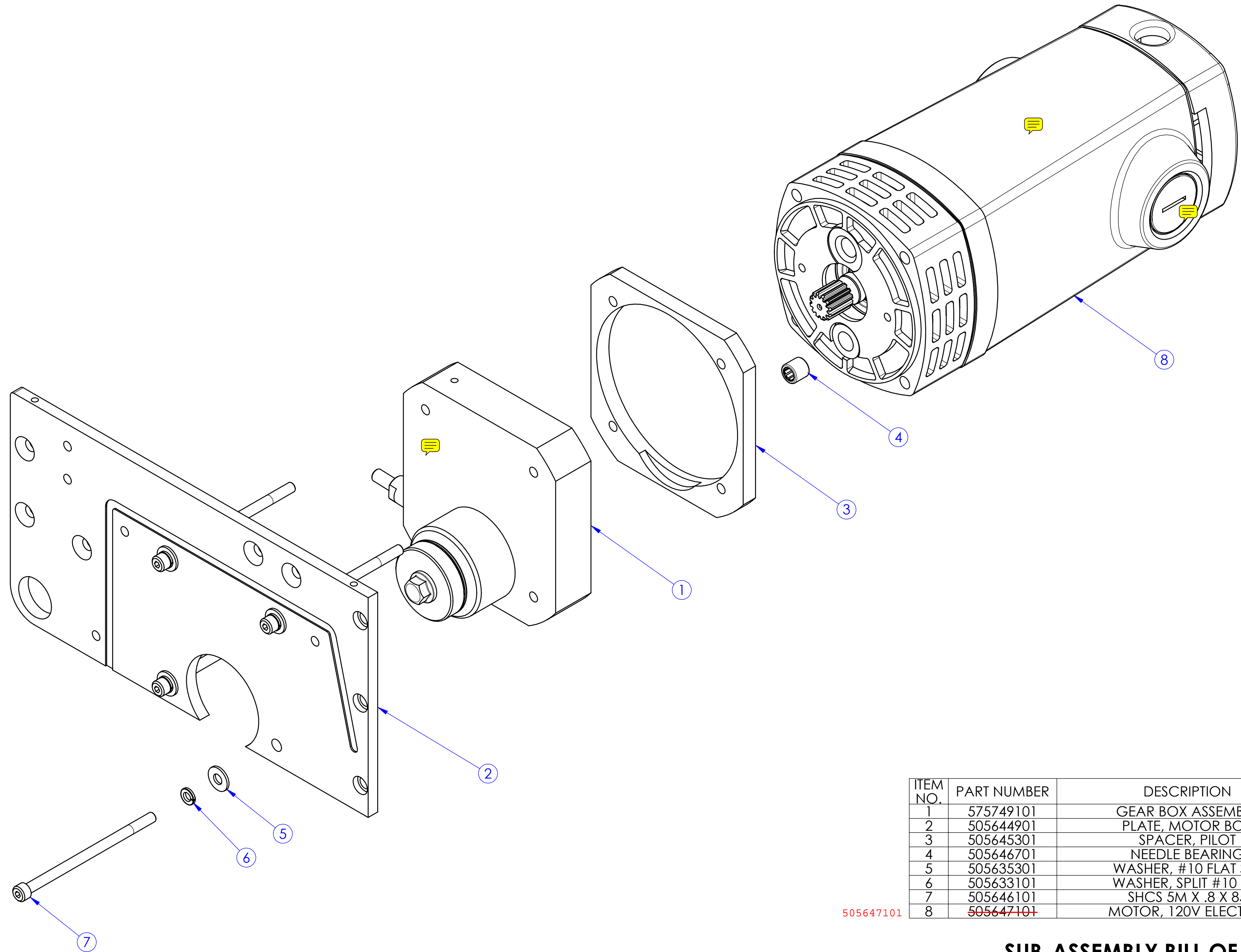

505647101

ITEM NO.	PART NUMBER	DESCRIPTION	QTY.
1	575749101	GEAR BOX ASSEMBLY	1
2	505644901	PLATE, MOTOR BOX	1
3	505645301	SPACER, PILOT	1
4	505646701	NEEDLE BEARING	1
5	505635301	WASHER, #10 FLAT S.S.	4
6	505633101	WASHER, SPLIT #10 S.S.	4
7	505646101	SHCS 5M X .8 X 85	4
8	505647101	MOTOR, 120V ELECTRIC	1

SUB-ASSEMBLY BILL OF MATERIAL

SOFF-CUT INT'L, INC. CLAIMS PROPRIETARY RIGHTS TO THE MATERIAL DISCLOSED IN THIS DOCUMENT. THIS DOCUMENT IS PROVIDED IN CONFIDENCE AND MAY NOT BE REPRODUCED OR DISCLOSED WITHOUT WRITTEN PERMISSION FROM SOFF-CUT INT'L. © COPYRIGHT 2006, SOFF-CUT INT'L, INC. ALL RIGHTS RESERVED.

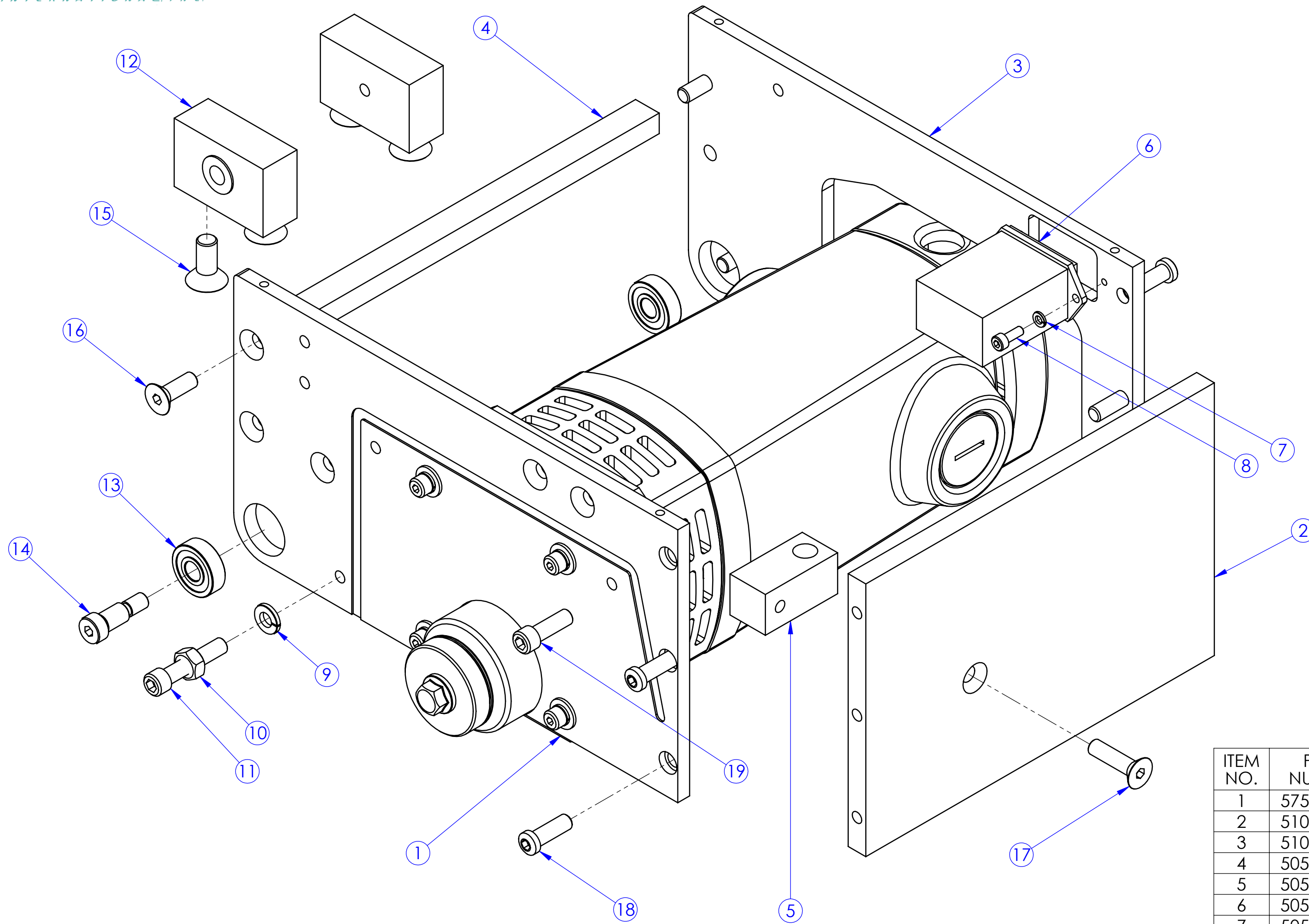

ITEM NO.	PART NUMBER	DESCRIPTION	QTY.
1	575747901	MOTOR AND GEARBOX ASSEMBLY	1
2	510320801	FRONT PLATE	1
3	510320701	PLATE, MOTOR REAR	1
4	505625801	BAR, SUPPORT BRACE	1
5	505625201	BLOCK, DEPTH GAUGE	1
6	505638601	HOUR METER, 120V60	1
7	505632401	WASHER, SPLIT #6 S.S.	2
8	505627601	SHCS 6-32 X 3/8 S.S.	2
9	505632801	WASHER, SPLIT 1/4" S.S.	1
10	505631901	NUT, 1/4-20 HEX, S.S.	1
11	505628001	SHCS 1/4-20 X 1 1/4 S.S.	1
12	505611901	PILLOW BLOCK, HANDLE (SHORT)	2
13	505635501	BALL BEARING, 8mm ID	2
14	505627001	SHSB, 5/16 X 1/2	2
15	505628801	FHS, 5/16-18 x 3/4 S.S.	4
16	505628601	FHS, 1/4-20 x 3/4 S.S.	2
17	505628701	FHS, 1/4-20 x 1 S.S.	1
18	505667201	GBHS, 1/4-20 X 3/4	5
19	505627801	SHCS 1/4-20 X 3/4 S.S.	1

SUB-ASSEMBLY BILL OF MATERIAL

SOFF-CUT INT'L, INC. CLAIMS PROPRIETARY RIGHTS TO THE MATERIAL DISCLOSED IN THIS DOCUMENT. THIS DOCUMENT IS PROVIDED IN CONFIDENCE AND MAY NOT BE REPRODUCED OR DISCLOSED WITHOUT WRITTEN PERMISSION FROM SOFF-CUT INT'L. © COPYRIGHT 2007, SOFF-CUT INT'L, INC. ALL RIGHTS RESERVED.

575747401

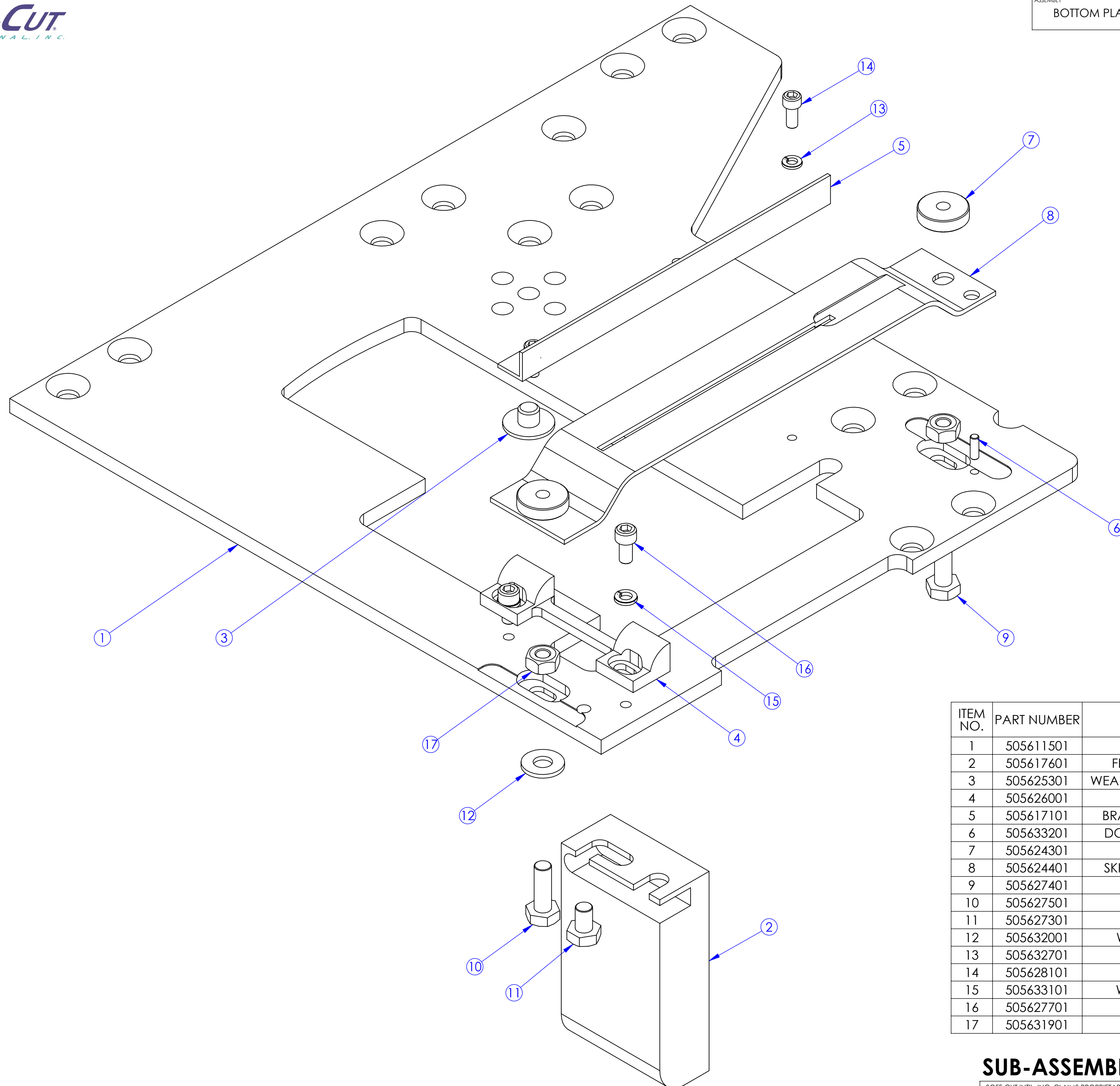

ITEM NO.	PART NUMBER	DESCRIPTION	QTY.
1	505611501	PLATE, BASE	1
2	505617601	FRONT DIVERTER BLOCK	1
3	505625301	WEAR BUTTON, STAINLESS STEEL	1
4	505626001	BLOCK, DIVERTER	1
5	505617101	BRACKET, ANGLE DIVERTER	1
6	505633201	DOWEL PIN .125 X .375 S.S.	1
7	505624301	THUMB NUT, 1/4-20	2
8	505624401	SKIDPLATE, 5.5" STANDARD	1
9	505627401	HHB 1/4-20 X .625 S.S.	1
10	505627501	HHB 1/4-20 X .75 S.S.	1
11	505627301	HHB 1/4-20 X .375 S.S.	1
12	505632001	WASHER, 1/4" FLAT S.S.	1
13	505632701	WASHER, SPLIT #8 S.S.	2
14	505628101	SHCS 8-32 X 3/8 S.S.	2
15	505633101	WASHER, SPLIT #10 S.S.	2
16	505627701	SHCS 10-32 X 3/8 S.S.	2
17	505631901	NUT, 1/4-20 HEX, S.S.	2

SUB-ASSEMBLY BILL OF MATERIAL

SOFF-CUT INT'L, INC. CLAIMS PROPRIETARY RIGHTS TO THE MATERIAL DISCLOSED IN THIS DOCUMENT. THIS DOCUMENT IS PROVIDED IN CONFIDENCE AND MAY NOT BE REPRODUCED OR DISCLOSED WITHOUT WRITTEN PERMISSION FROM SOFF-CUT INT'L. © COPYRIGHT 2007, SOFF-CUT INT'L, INC. ALL RIGHTS RESERVED.

575748001

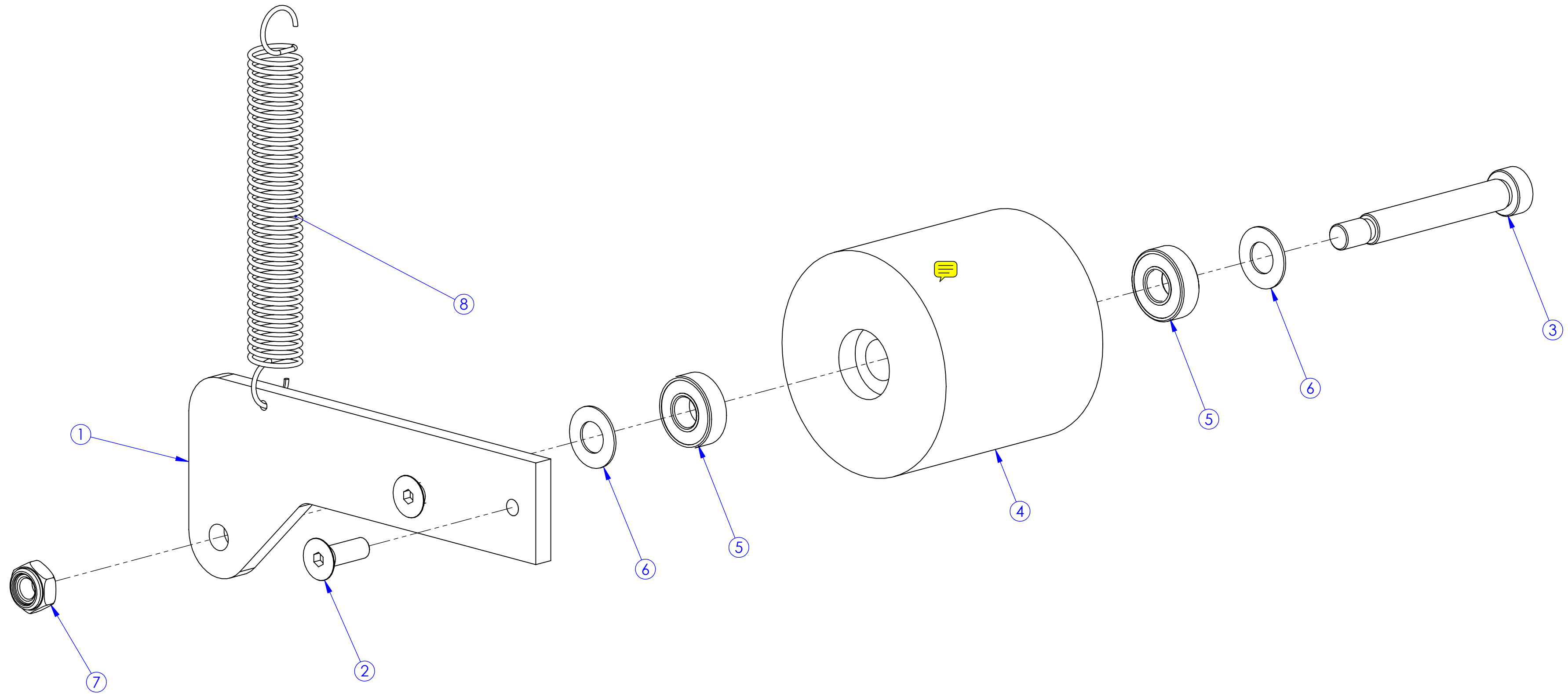

ITEM NO.	PART NUMBER	DESCRIPTION	QTY.
1	505615801	ARM, BACK-UP	1
2	505628601	FHS, 1/4-20 x 3/4 S.S.	2
3	505627201	SHSB, 3/8 X 2 1/4	1
4	505636601	WHEEL, 2.75 OD X 2.63, GRAY	1
5	505635601	BEARING, .375 ID, R6-2RS	2
6	505634201	WASHER, 3/8"X .03"THK FLAT S.S.	2
7	505631701	NUT, NYLOC, 5/16-18 .265 HT.	1
8	505635901	SPRING, EXTENSION	1

SUB-ASSEMBLY BILL OF MATERIAL

SOFF-CUT INT'L. INC. CLAIMS PROPRIETARY RIGHTS TO THE MATERIAL DISCLOSED IN THIS DOCUMENT. THIS DOCUMENT IS PROVIDED IN CONFIDENCE AND MAY NOT BE REPRODUCED OR DISCLOSED WITHOUT WRITTEN PERMISSION FROM SOFF-CUT INT'L. © COPYRIGHT 2007, SOFF-CUT INT'L, INC. ALL RIGHTS RESERVED.

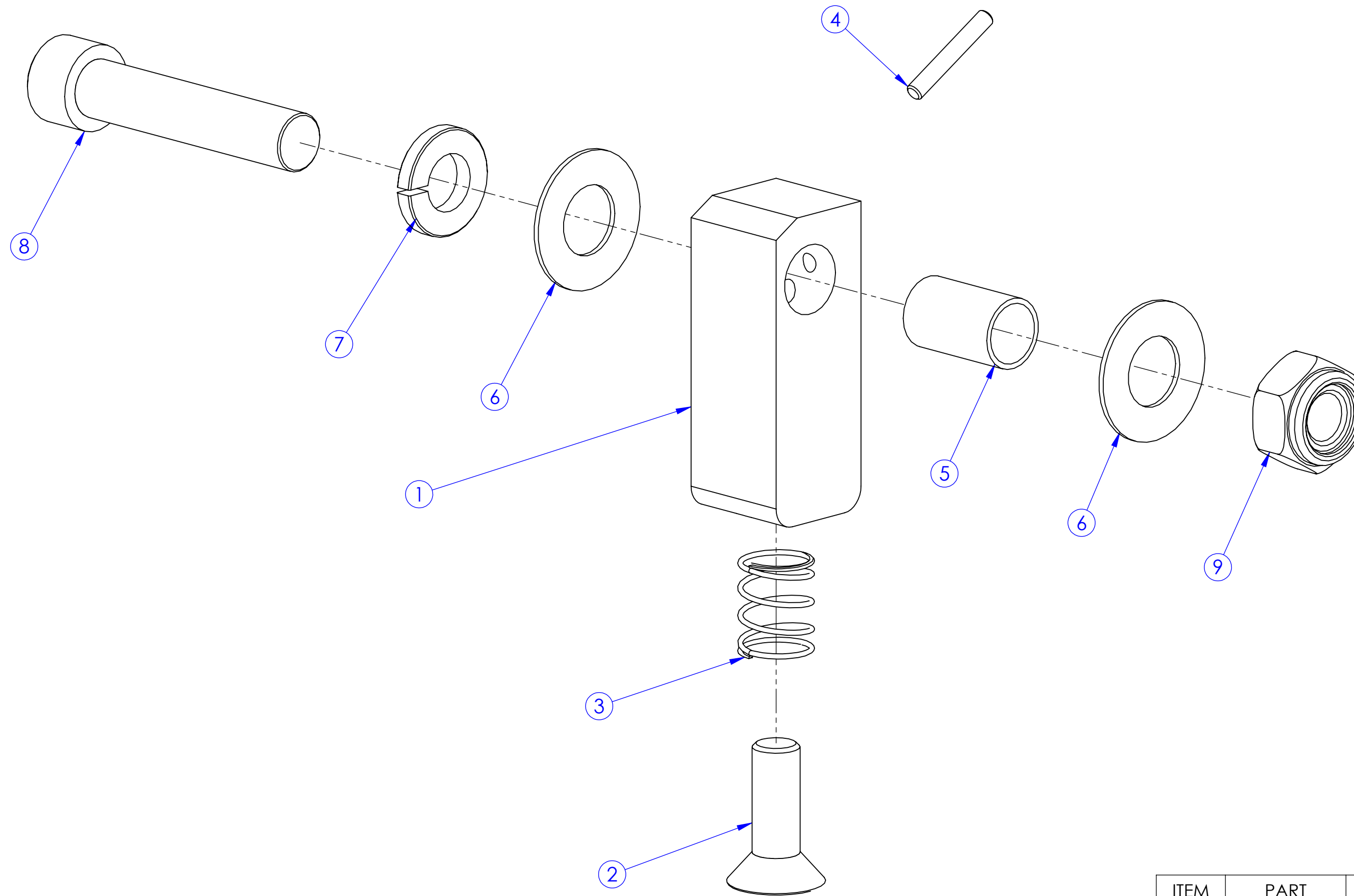

ITEM NO.	PART NUMBER	DESCRIPTION	QTY.
1	505615001	BLOCK, PENDULUM	1
2	505628601	FHS, 1/4-20 x 3/4 S.S.	1
3	505636401	SPRING, COMPRESSION	1
4	505633301	DOWEL PIN .094 X .625 STEEL	1
5	505617201	SPACER	1
6	505634501	WASHER, 3/8" DELRIN	2
7	505633001	WASHER, SPLIT 5/16" S.S.	1
8	505628401	SHCS 5/16-18 X 1 1/2 S.S.	1
9	505630601	NUT, NYLOC, 5/16-18 CAD	1

SUB-ASSEMBLY BILL OF MATERIAL

SOFF-CUT INT'L, INC. CLAIMS PROPRIETARY RIGHTS TO THE MATERIAL DISCLOSED IN THIS DOCUMENT. THIS DOCUMENT IS PROVIDED IN CONFIDENCE AND MAY NOT BE REPRODUCED OR DISCLOSED WITHOUT WRITTEN PERMISSION FROM SOFF-CUT INT'L. © COPYRIGHT 2007, SOFF-CUT INT'L, INC. ALL RIGHTS RESERVED.

575748201

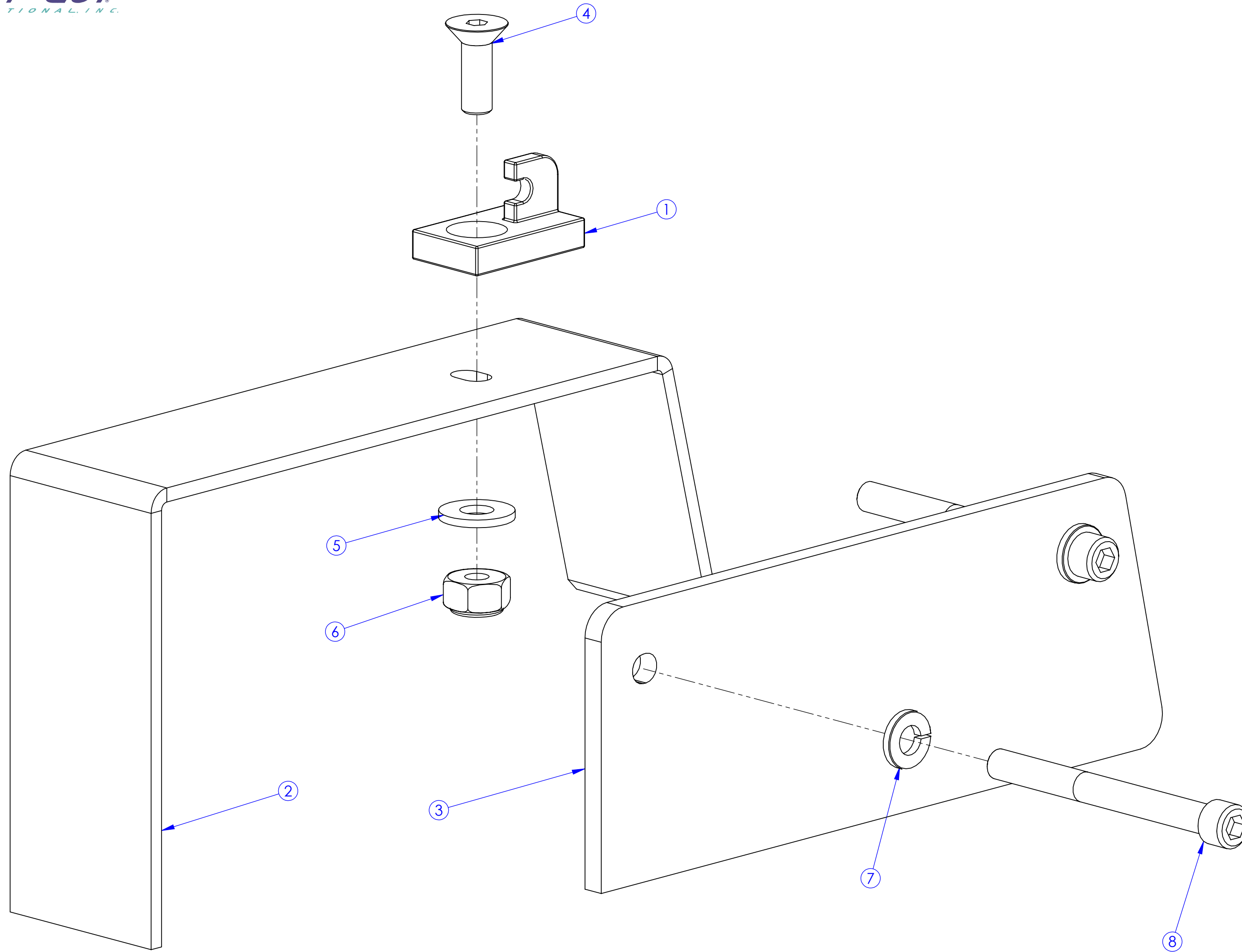

ITEM NO.	PART NUMBER	DESCRIPTION	QTY.
1	505616801	LATCH, GUIDE ARM	1
2	505616501	SHROUD	1
3	505616601	BLADE COVER	1
4	505628601	FHS, 1/4-20 x 3/4 S.S.	1
5	505632001	WASHER, 1/4" FLAT S.S.	1
6	505630501	NUT, NYLOC, 1/4-20 CAD	1
7	505632801	WASHER, SPLIT 1/4" S.S.	2
8	505628301	SHCS 1/4-20 X 2 1/2 S.S.	2

SUB-ASSEMBLY BILL OF MATERIAL

SOFF-CUT INT'L. INC. CLAIMS PROPRIETARY RIGHTS TO THE MATERIAL DISCLOSED IN THIS DOCUMENT. THIS DOCUMENT IS PROVIDED IN CONFIDENCE AND MAY NOT BE REPRODUCED OR DISCLOSED WITHOUT WRITTEN PERMISSION FROM SOFF-CUT INT'L. © COPYRIGHT 2007, SOFF-CUT INT'L, INC. ALL RIGHTS RESERVED.

575748301

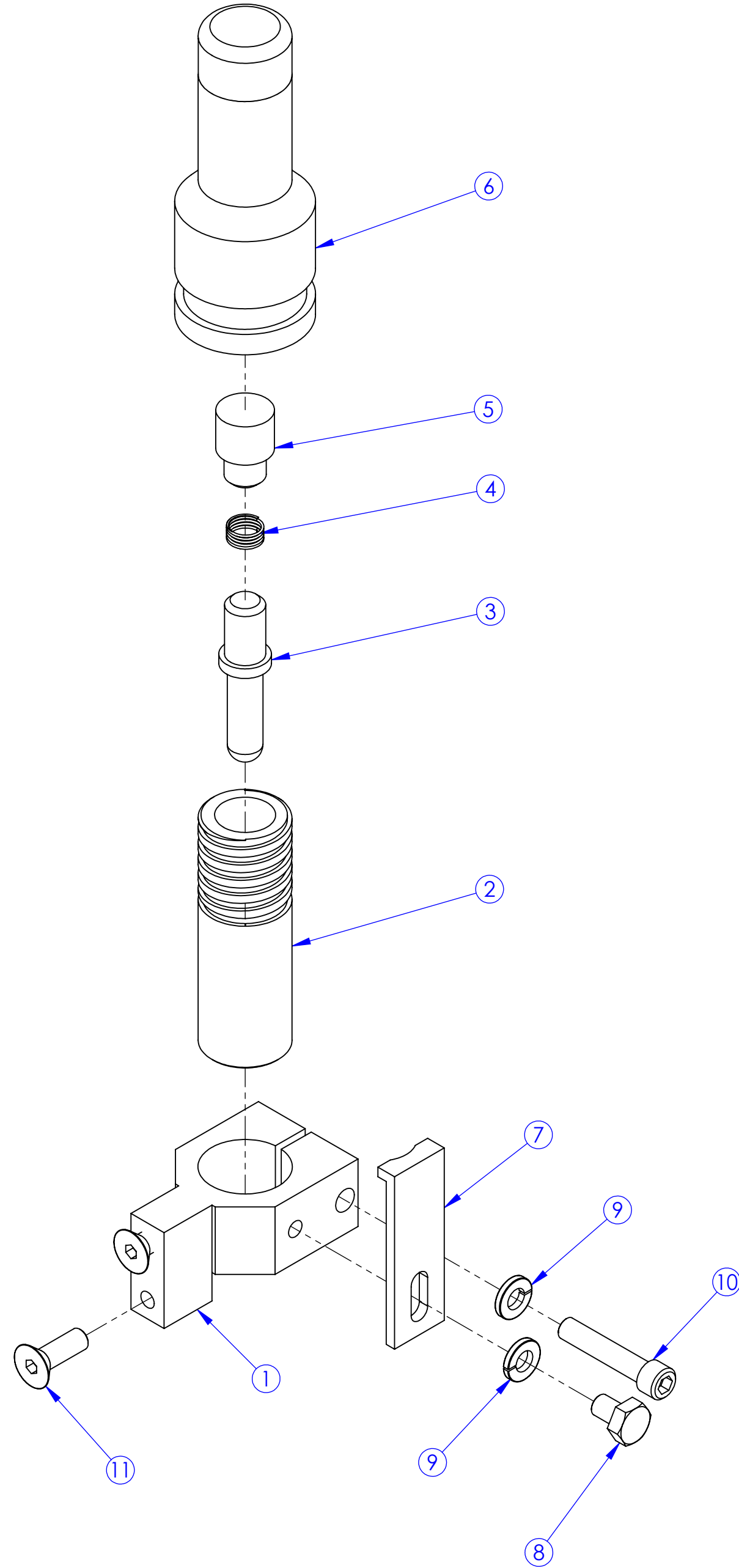

ITEM NO.	PART NUMBER	DESCRIPTION	QTY.
1	505624801	BLOCK, PRESSURE GAUGE	1
2	505624701	PRESSURE GAGE BLOCK	1
3	505617401	PRESSURE BLOCK ROD	1
4	505636401	SPRING, COMPRESSION	1
5	505625101	SPRING CAP/PRESSURE BLOCK	1
6	505624901	KNOB, PRESSURE BLOCK	1
7	505625701	PRESSURE BLOCK STOP	1
8	505627301	HHB 1/4-20 X .375 S.S.	1
9	505632801	WASHER, SPLIT 1/4" S.S.	2
10	505628001	SHCS 1/4-20 X 1 1/4 S.S.	1
11	505628601	FHS, 1/4-20 x 3/4 S.S.	2

SUB-ASSEMBLY BILL OF MATERIAL

SOFF-CUT INT'L, INC. CLAIMS PROPRIETARY RIGHTS TO THE MATERIAL DISCLOSED IN THIS DOCUMENT. THIS DOCUMENT IS PROVIDED IN CONFIDENCE AND MAY NOT BE REPRODUCED OR DISCLOSED WITHOUT WRITTEN PERMISSION FROM SOFF-CUT INT'L. © COPYRIGHT 2007, SOFF-CUT INT'L, INC. ALL RIGHTS RESERVED.

575748401

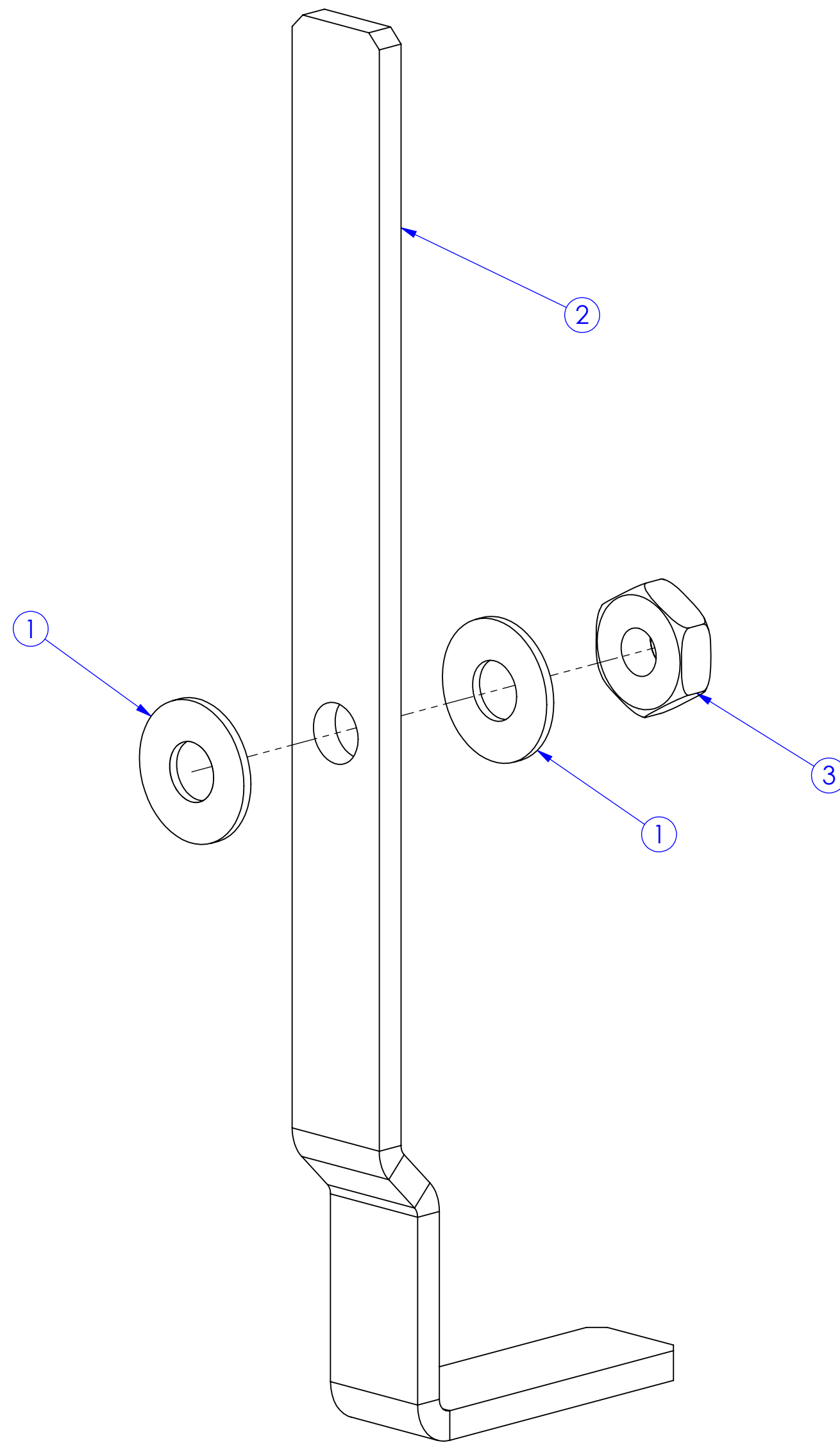

ITEM NO.	PART NUMBER	DESCRIPTION	QTY.
1	505634401	WASHER, 1/4" DELRIN	2
2	505645001	LEVER, ARBOR LOCK	1
3	505630701	NUT, NYLOC, 1/4-20 .218 HT.	1

SUB-ASSEMBLY BILL OF MATERIAL

SOFF-CUT INT'L, INC. CLAIMS PROPRIETARY RIGHTS TO THE MATERIAL DISCLOSED IN THIS DOCUMENT. THIS DOCUMENT IS PROVIDED IN CONFIDENCE AND MAY NOT BE REPRODUCED OR DISCLOSED WITHOUT WRITTEN PERMISSION FROM SOFF-CUT INT'L. © COPYRIGHT 2007, SOFF-CUT INT'L, INC. ALL RIGHTS RESERVED.

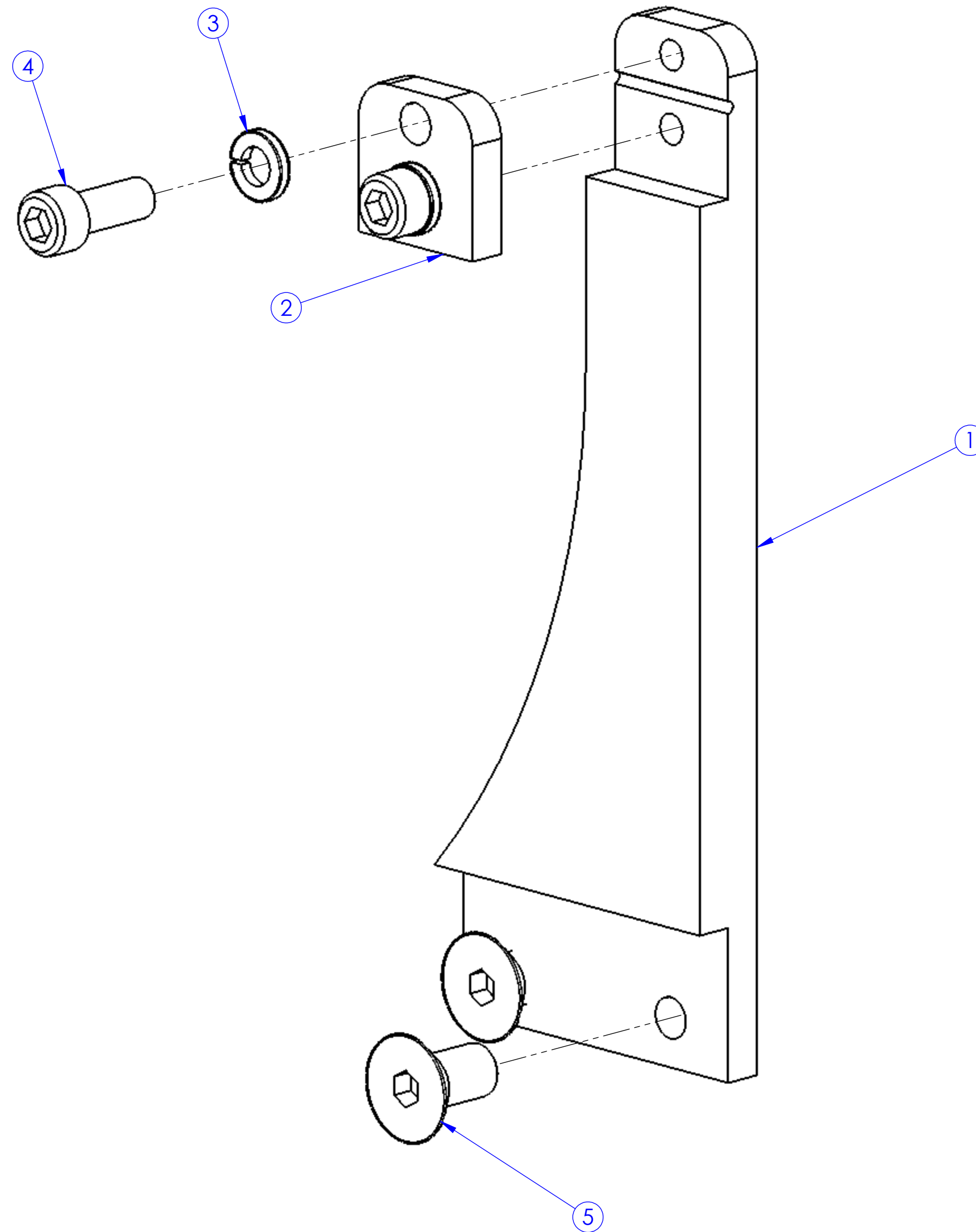

ITEM NO.	PART NUMBER	DESCRIPTION	QTY.
1	505618101	CABLE MOUNT ARM	1
2	505626101	BLOCK, CABLE MOUNT	1
3	505633101	WASHER, SPLIT #10 S.S.	2
4	505772401	SHCS 10-24 X 1/2 S.S.	2
5	505628501	FHS, 1/4-20 x 1/2 S.S.	2

SUB-ASSEMBLY BILL OF MATERIAL

SOFF-CUT INT'L, INC. CLAIMS PROPRIETARY RIGHTS TO THE MATERIAL DISCLOSED IN THIS DOCUMENT. THIS DOCUMENT IS PROVIDED IN CONFIDENCE AND MAY NOT BE REPRODUCED OR DISCLOSED WITHOUT WRITTEN PERMISSION FROM SOFF-CUT INT'L. © COPYRIGHT 2007, SOFF-CUT INT'L, INC. ALL RIGHTS RESERVED.

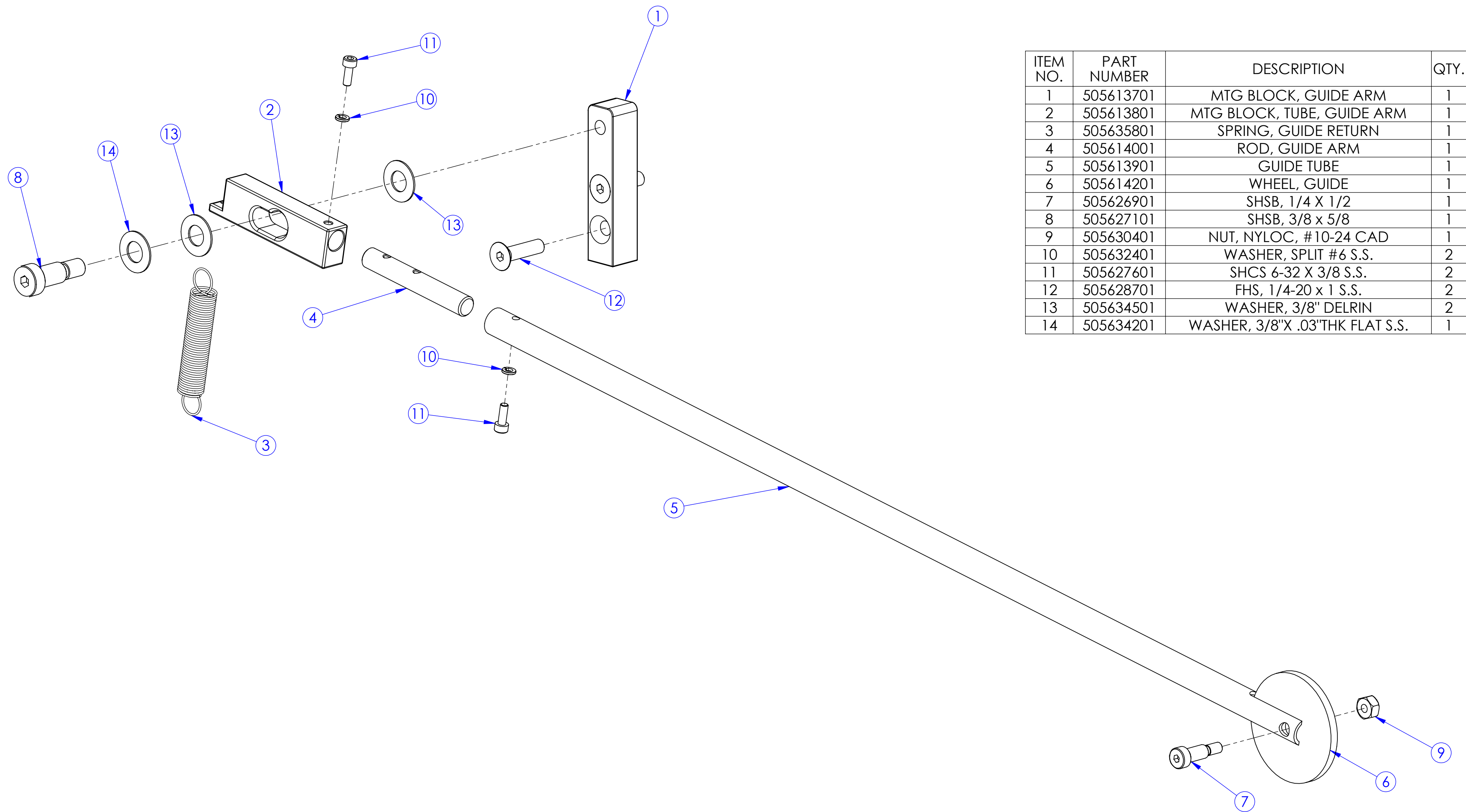

ITEM NO.	PART NUMBER	DESCRIPTION	QTY.
1	505613701	MTG BLOCK, GUIDE ARM	1
2	505613801	MTG BLOCK, TUBE, GUIDE ARM	1
3	505635801	SPRING, GUIDE RETURN	1
4	505614001	ROD, GUIDE ARM	1
5	505613901	GUIDE TUBE	1
6	505614201	WHEEL, GUIDE	1
7	505626901	SHSB, 1/4 X 1/2	1
8	505627101	SHSB, 3/8 x 5/8	1
9	505630401	NUT, NYLOC, #10-24 CAD	1
10	505632401	WASHER, SPLIT #6 S.S.	2
11	505627601	SHCS 6-32 X 3/8 S.S.	2
12	505628701	FHS, 1/4-20 x 1 S.S.	2
13	505634501	WASHER, 3/8" DELRIN	2
14	505634201	WASHER, 3/8"X .03"THK FLAT S.S.	1

SUB-ASSEMBLY BILL OF MATERIAL

SOFF-CUT INT'L, INC. CLAIMS PROPRIETARY RIGHTS TO THE MATERIAL DISCLOSED IN THIS DOCUMENT. THIS DOCUMENT IS PROVIDED IN CONFIDENCE AND MAY NOT BE REPRODUCED OR DISCLOSED WITHOUT WRITTEN PERMISSION FROM SOFF-CUT INT'L. © COPYRIGHT 2007, SOFF-CUT INT'L, INC. ALL RIGHTS RESERVED.

575748801

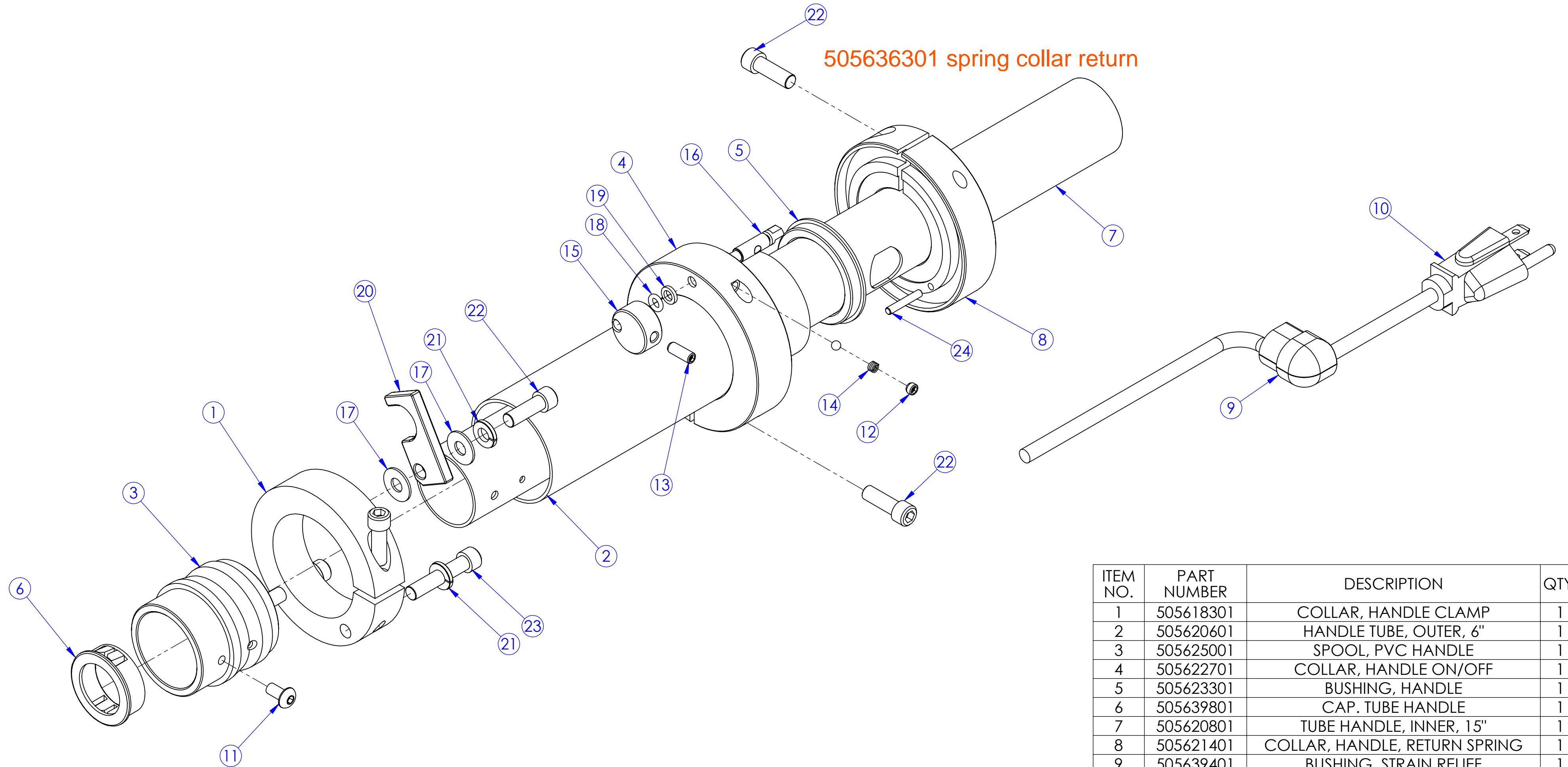

ITEM NO.	PART NUMBER	DESCRIPTION	QTY.
1	505618301	COLLAR, HANDLE CLAMP	1
2	505620601	HANDLE TUBE, OUTER, 6"	1
3	505625001	SPOOL, PVC HANDLE	1
4	505622701	COLLAR, HANDLE ON/OFF	1
5	505623301	BUSHING, HANDLE	1
6	505639801	CAP. TUBE HANDLE	1
7	505620801	TUBE HANDLE, INNER, 15"	1
8	505621401	COLLAR, HANDLE, RETURN SPRING	1
9	505639401	BUSHING, STRAIN RELIEF	1
10	505638701	POWER CORD	1
11	505629101	BHS, 10-32 X 3/8 S.S.	1
12	505630201	SET SCREW, FLAT 10-32 X .125 S.S.	1
13	505630101	SET SCREW, FLAT 10-32 X .500 S.S.	1
14	505636201	SPRING	1
15	505623401	ON/OFF KNOB	1
16	505623701	PIN, ON/OFF	1
17	505634401	WASHER, 1/4" DELRIN	2
18	505646001	O-RING 3/16 ID X .070 THK	1
19	505634301	WASHER, #10 X .06"THK DELRIN	1
20	505616901	LATCH. GUIDE ARM	1
21	505632801	WASHER, SPLIT 1/4" S.S.	3
22	505627801	SHCS 1/4-20 X 3/4 S.S.	4
23	505628001	SHCS 1/4-20 X 1 1/4 S.S.	2
24	505804601	DOWEL PIN .125 X .750 STEEL	1

SUB-ASSEMBLY BILL OF MATERIAL

SOFF-CUT INT'L, INC. CLAIMS PROPRIETARY RIGHTS TO THE MATERIAL DISCLOSED IN THIS DOCUMENT. THIS DOCUMENT IS PROVIDED IN CONFIDENCE AND MAY NOT BE REPRODUCED OR DISCLOSED WITHOUT WRITTEN PERMISSION FROM SOFF-CUT INT'L. © COPYRIGHT 2007, SOFF-CUT INT'L, INC. ALL RIGHTS RESERVED.

575748601

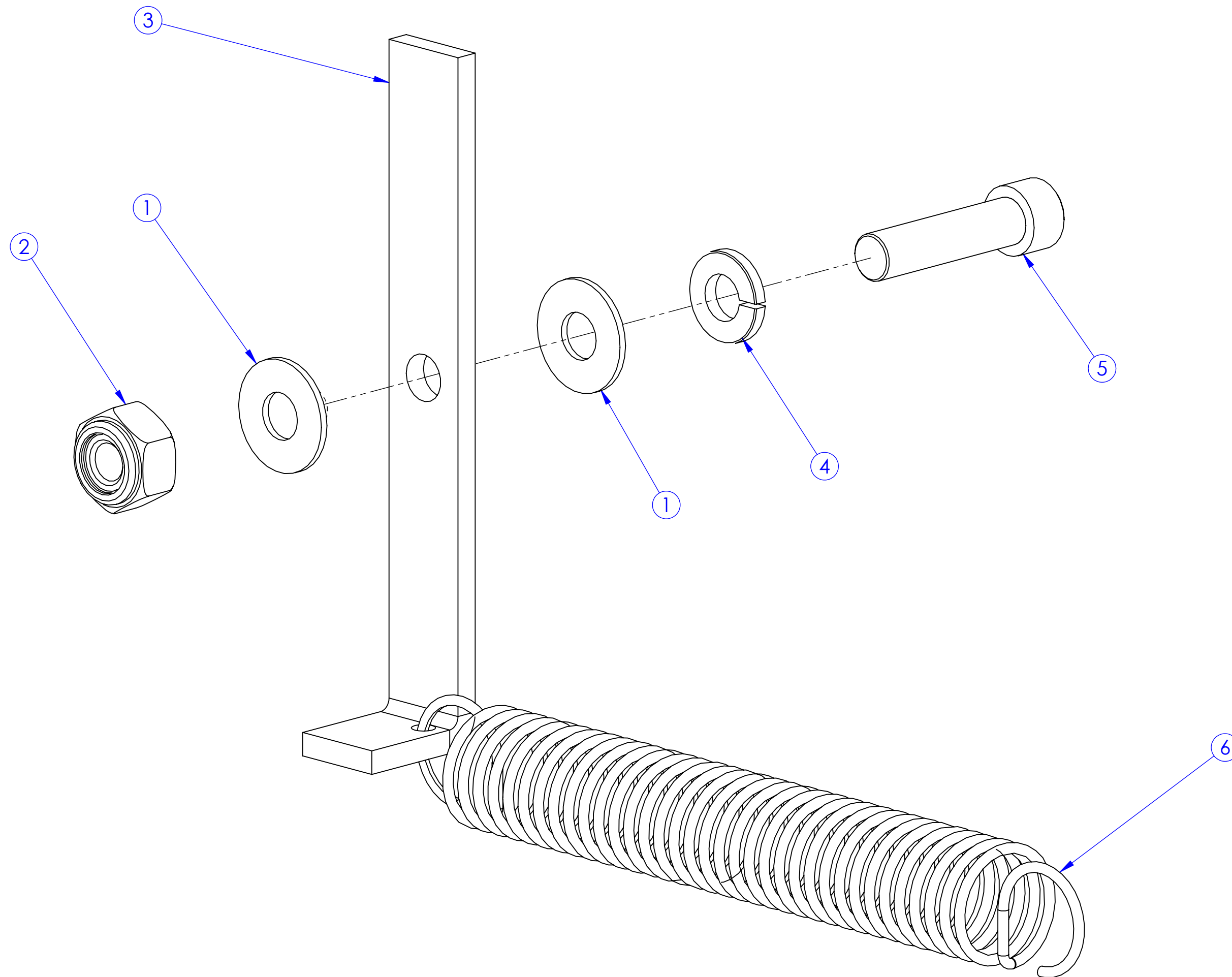

ITEM NO.	PART NUMBER	DESCRIPTION	QTY.
1	505634401	WASHER, 1/4" DELRIN	2
2	505630501	NUT, NYLOC, 1/4-20 CAD	1
3	505621601	LEVER, BOX RELEASE	1
4	505632801	WASHER, SPLIT 1/4" S.S.	1
5	505627901	SHCS 1/4-20 X 1 S.S.	1
6	505635901	SPRING, EXTENSION	1

SUB-ASSEMBLY BILL OF MATERIAL

SOFF-CUT INT'L. INC. CLAIMS PROPRIETARY RIGHTS TO THE MATERIAL DISCLOSED IN THIS DOCUMENT. THIS DOCUMENT IS PROVIDED IN CONFIDENCE AND MAY NOT BE REPRODUCED OR DISCLOSED WITHOUT WRITTEN PERMISSION FROM SOFF-CUT INT'L. © COPYRIGHT 2007, SOFF-CUT INT'L, INC. ALL RIGHTS RESERVED.

575747601

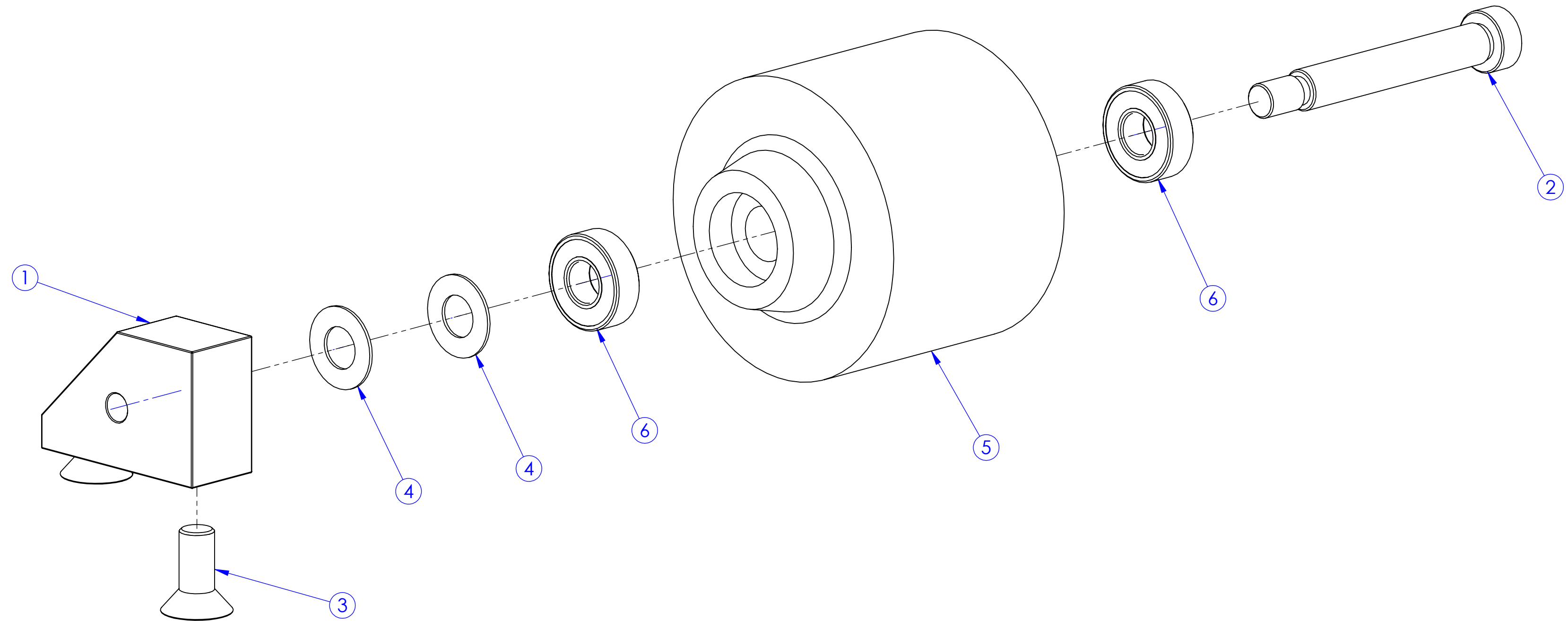

ITEM NO.	PART NUMBER	DESCRIPTION	QTY.
1	505645601	BLOCK, FRONT WHEEL	1
2	505627201	SHSB, 3/8 X 2 1/4	1
3	505628801	FHS, 5/16-18 x 3/4 S.S.	2
4	505634201	WASHER, 3/8"X .03"THK FLAT S.S.	2
5	505646901	WHEEL, CHOPPED, GRAY	1
6	505635601	BEARING, .375 ID, R6-2RS	2

SUB-ASSEMBLY BILL OF MATERIAL

SOFF-CUT INT'L, INC. CLAIMS PROPRIETARY RIGHTS TO THE MATERIAL DISCLOSED IN THIS DOCUMENT. THIS DOCUMENT IS PROVIDED IN CONFIDENCE AND MAY NOT BE REPRODUCED OR DISCLOSED WITHOUT WRITTEN PERMISSION FROM SOFF-CUT INT'L. © COPYRIGHT 2007, SOFF-CUT INT'L, INC. ALL RIGHTS RESERVED.

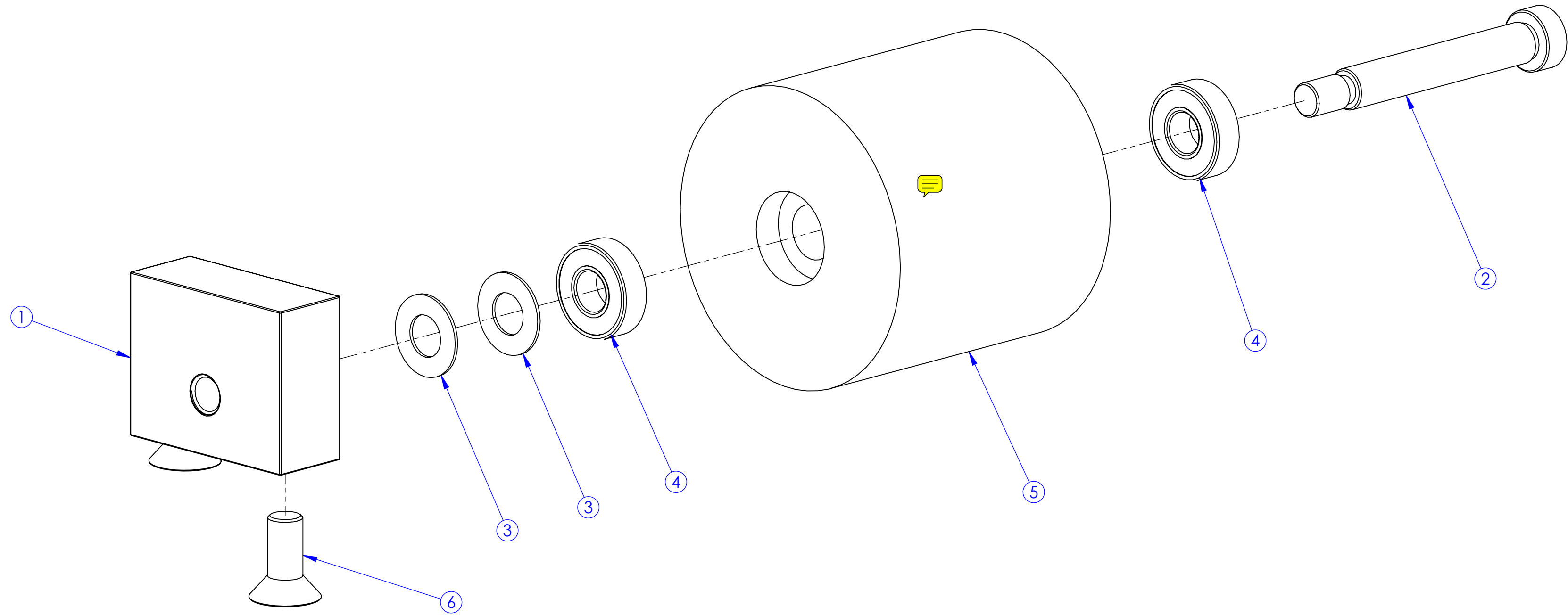

ITEM NO.	PART NUMBER	DESCRIPTION	QTY.
1	505612101	BLOCK, BACK WHEEL	1
2	505627201	SHSB, 3/8 X 2 1/4	1
3	505634201	WASHER, 3/8"X .03"THK FLAT S.S.	2
4	505635601	BEARING, .375 ID, R6-2RS	2
5	505636601	WHEEL, 2.75 OD X 2.63, GRAY	1
6	505628801	FHS, 5/16-18 x 3/4 S.S.	2

SUB-ASSEMBLY BILL OF MATERIAL

SOFF-CUT INT'L, INC. CLAIMS PROPRIETARY RIGHTS TO THE MATERIAL DISCLOSED IN THIS DOCUMENT. THIS DOCUMENT IS PROVIDED IN CONFIDENCE AND MAY NOT BE REPRODUCED OR DISCLOSED WITHOUT WRITTEN PERMISSION FROM SOFF-CUT INT'L. © COPYRIGHT 2007, SOFF-CUT INT'L, INC. ALL RIGHTS RESERVED.

575748701

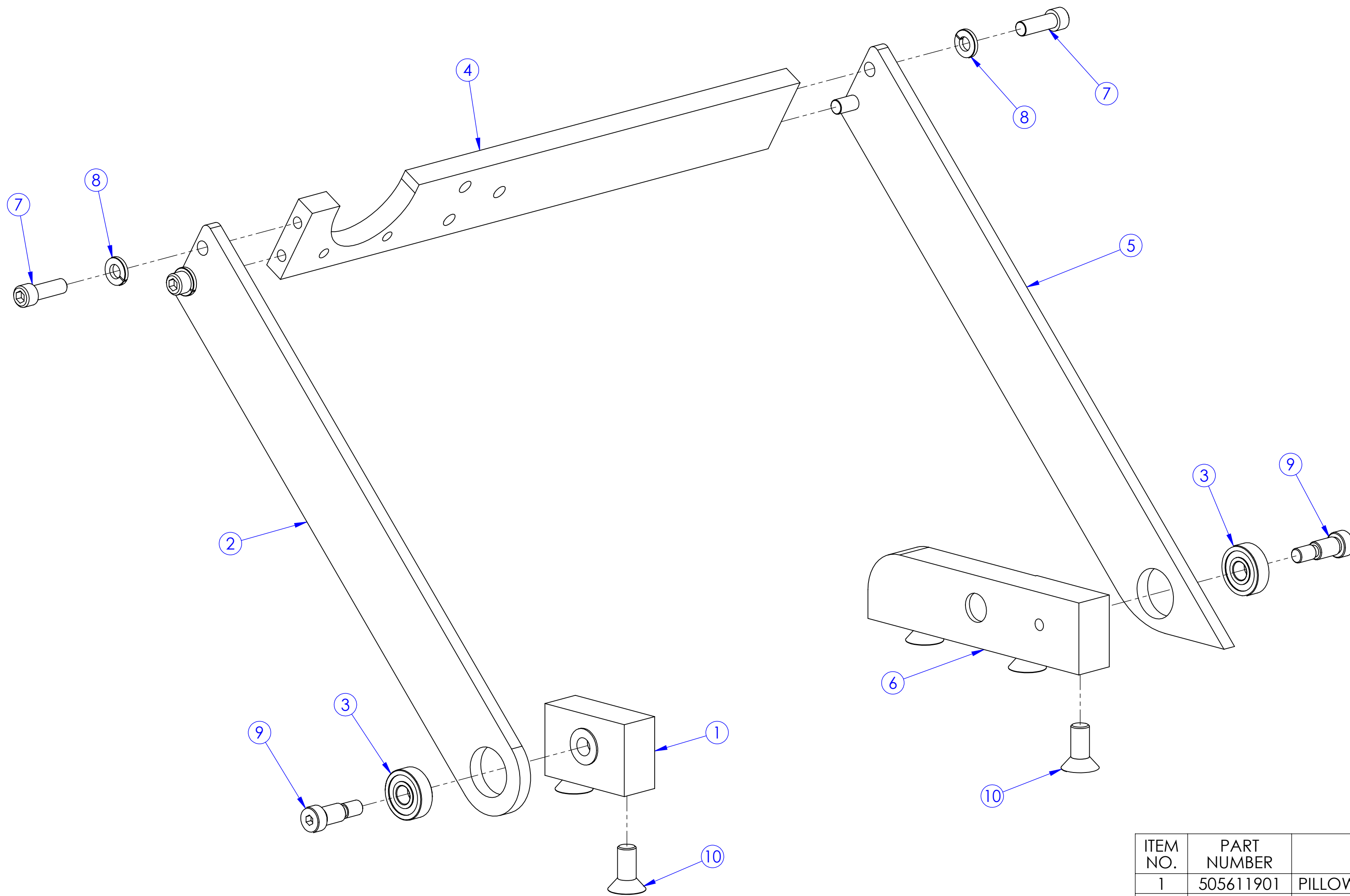

ITEM NO.	PART NUMBER	DESCRIPTION	QTY.
1	505611901	PILLOW BLOCK, HANDLE (SHORT)	1
2	505616301	HANDLE, RIGHT ARM	1
3	505635501	BALL BEARING, 8mm ID	2
4	505615901	REAR HANDLE PLATE	1
5	505616401	HANDLE, LEFT ARM	1
6	505613201	PILLOW BLOCK, HANDLE (LONG)	1
7	505627801	SHCS 1/4-20 X 3/4 S.S.	4
8	505632801	WASHER, SPLIT 1/4" S.S.	4
9	505627001	SHSB, 5/16 X 1/2	2
10	505628801	FHS, 5/16-18 x 3/4 S.S.	5

SUB-ASSEMBLY BILL OF MATERIAL

SOFF-CUT INT'L, INC. CLAIMS PROPRIETARY RIGHTS TO THE MATERIAL DISCLOSED IN THIS DOCUMENT. THIS DOCUMENT IS PROVIDED IN CONFIDENCE AND MAY NOT BE REPRODUCED OR DISCLOSED WITHOUT WRITTEN PERMISSION FROM SOFF-CUT INT'L. © COPYRIGHT 2007, SOFF-CUT INT'L, INC. ALL RIGHTS RESERVED.

575748901

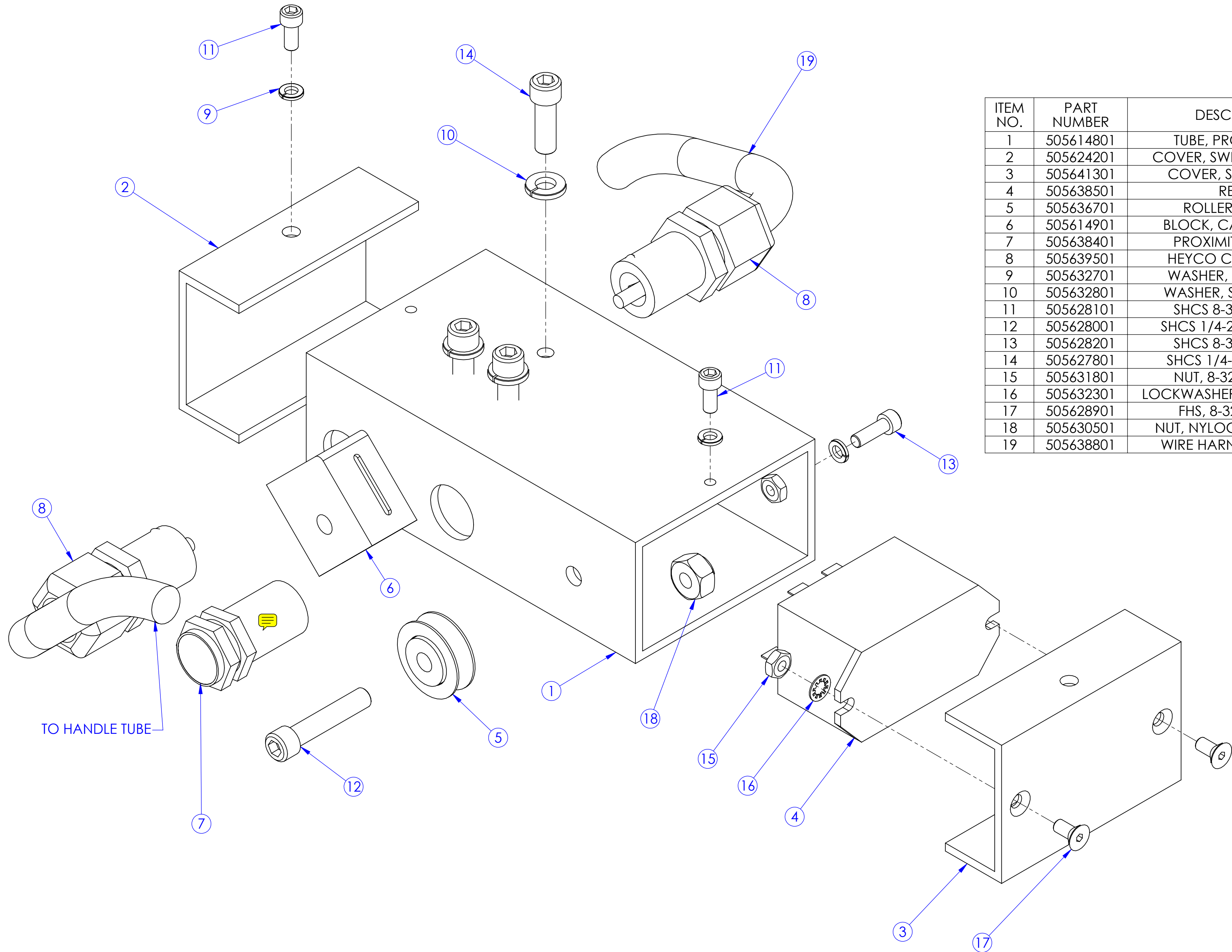

ITEM NO.	PART NUMBER	DESCRIPTION	QTY.
1	505614801	TUBE, PROX SWITCH	1
2	505624201	COVER, SWITCH, BOTTOM	1
3	505641301	COVER, SWITCH TUBE	1
4	505638501	RELAY	1
5	505636701	ROLLER, 1", STEEL	1
6	505614901	BLOCK, CABLE ROLLER	1
7	505638401	PROXIMITY OMRON	1
8	505639501	HEYCO CONNECTOR	2
9	505632701	WASHER, SPLIT #8 S.S.	3
10	505632801	WASHER, SPLIT 1/4" S.S.	3
11	505628101	SHCS 8-32 X 3/8 S.S.	2
12	505628001	SHCS 1/4-20 X 1 1/4 S.S.	1
13	505628201	SHCS 8-32 X 1/2 S.S.	1
14	505627801	SHCS 1/4-20 X 3/4 S.S.	3
15	505631801	NUT, 8-32 HEX, ZINC	3
16	505632301	LOCKWASHER, #8 INT TOOTH	2
17	505628901	FHS, 8-32 x 3/8 S.S.	2
18	505630501	NUT, NYLOC, 1/4-20 CAD	1
19	505638801	WIRE HARNESS, MOTOR	1

SUB-ASSEMBLY BILL OF MATERIAL

SOFF-CUT INTL, INC. CLAIMS PROPRIETARY RIGHTS TO THE MATERIAL DISCLOSED IN THIS DOCUMENT. THIS DOCUMENT IS PROVIDED IN CONFIDENCE AND MAY NOT BE REPRODUCED OR DISCLOSED WITHOUT WRITTEN PERMISSION FROM SOFF-CUT INTL. © COPYRIGHT 2007, SOFF-CUT INTL, INC. ALL RIGHTS RESERVED.

575749201

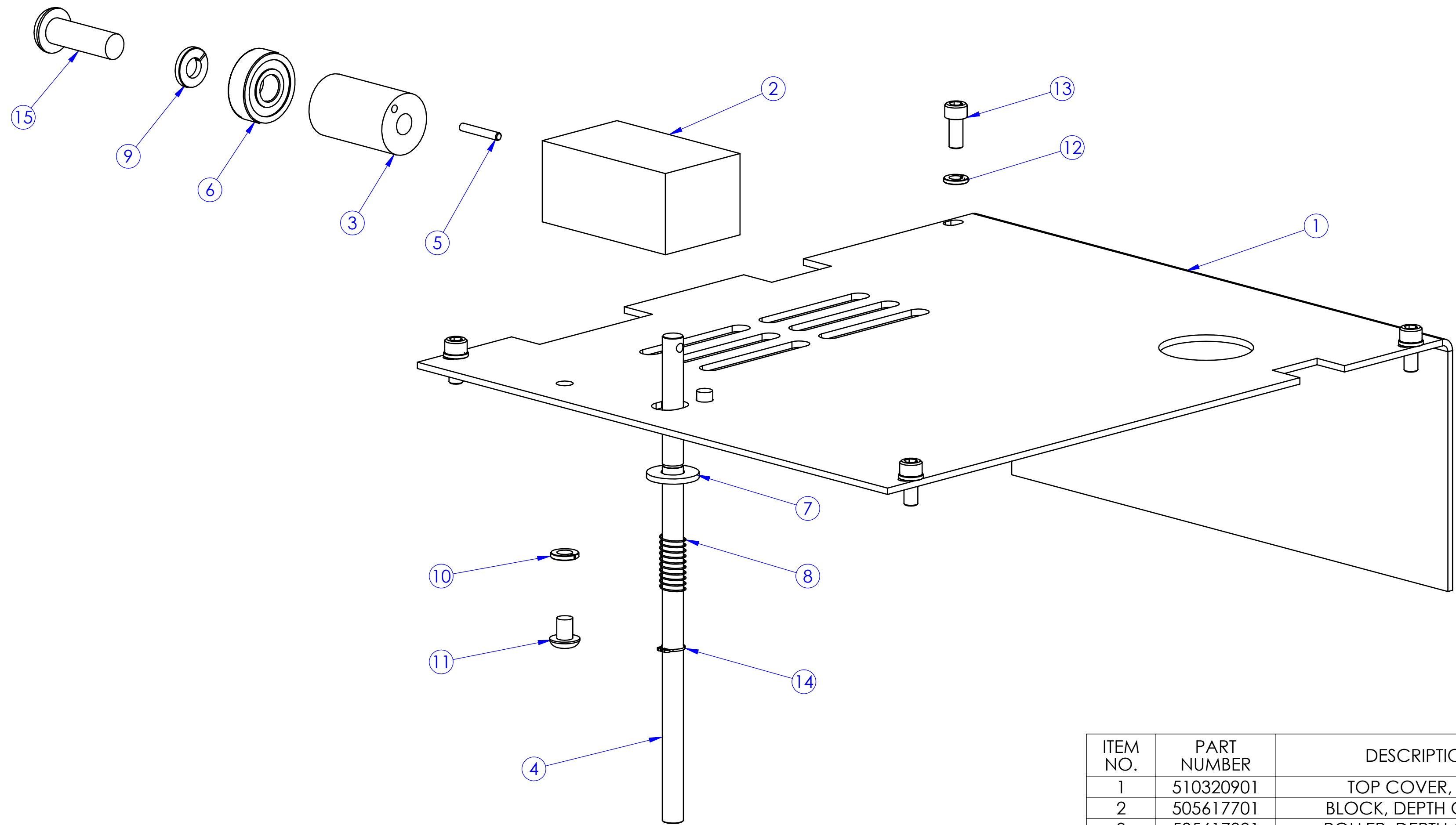

ITEM NO.	PART NUMBER	DESCRIPTION	QTY.
1	510320901	TOP COVER, BOX	1
2	505617701	BLOCK, DEPTH GAUGE	1
3	505617801	ROLLER, DEPTH GAUGE	1
4	516027001	ROD, STEEL DEPTH	1
5	505633301	DOWEL PIN .094 X .625 STEEL	1
6	505635501	BALL BEARING, 8mm ID	1
7	505632001	WASHER, 1/4" FLAT S.S.	1
8	505636101	SPRING, DEPTH GAUGE	1
9	505632801	WASHER, SPLIT 1/4" S.S.	1
10	505633101	WASHER, SPLIT #10 S.S.	2
11	505629501	BHS, 10-32 X 1/4 S.S.	2
12	505632701	WASHER, SPLIT #8 S.S.	4
13	505628101	SHCS 8-32 X 3/8 S.S.	4
14	505646201	SNAP RING, EXT .250"	1
15	505773501	BHS, 5/16-18 X 1	1

SUB-ASSEMBLY BILL OF MATERIAL

SOFF-CUT INT'L, INC. CLAIMS PROPRIETARY RIGHTS TO THE MATERIAL DISCLOSED IN THIS DOCUMENT. THIS DOCUMENT IS PROVIDED IN CONFIDENCE AND MAY NOT BE REPRODUCED OR DISCLOSED WITHOUT WRITTEN PERMISSION FROM SOFF-CUT INT'L. © COPYRIGHT 2007, SOFF-CUT INT'L, INC. ALL RIGHTS RESERVED.

505491302

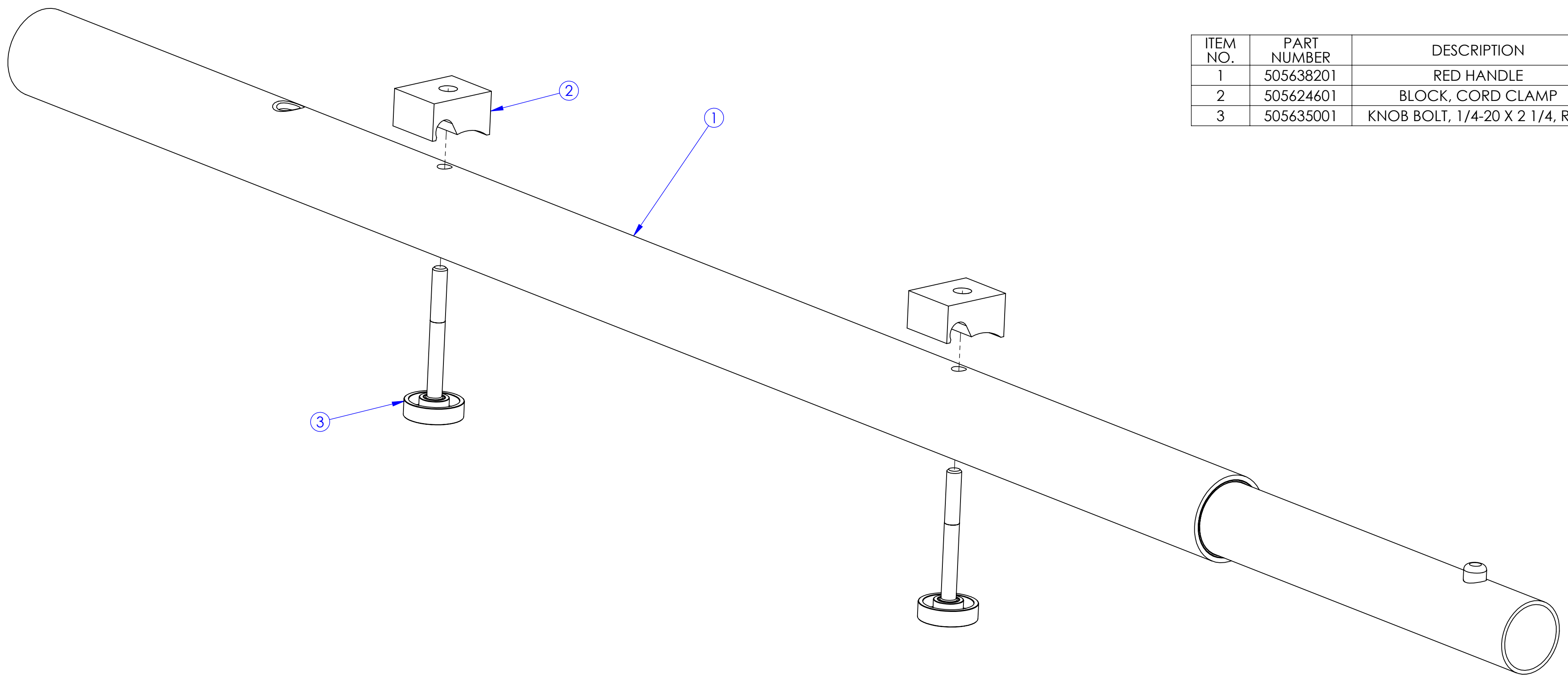

ITEM NO.	PART NUMBER	DESCRIPTION	QTY.
1	505638201	RED HANDLE	1
2	505624601	BLOCK, CORD CLAMP	2
3	505635001	KNOB BOLT, 1/4-20 X 2 1/4, RED	2

SUB-ASSEMBLY BILL OF MATERIAL

SOFF-CUT INT'L, INC. CLAIMS PROPRIETARY RIGHTS TO THE MATERIAL DISCLOSED IN THIS DOCUMENT. THIS DOCUMENT IS PROVIDED IN CONFIDENCE AND MAY NOT BE REPRODUCED OR DISCLOSED WITHOUT WRITTEN PERMISSION FROM SOFF-CUT INT'L. © COPYRIGHT 2007, SOFF-CUT INT'L, INC. ALL RIGHTS RESERVED.