







Click Here To View  
Item at

[www.GapPower.com](http://www.GapPower.com)

*Sales • Rentals  
Parts & Service*



The **TRANSCUBE™ 10TCG** is a compact, transportable, double-walled fuel tank. Quickly and easily supply fuel where you need it, when you need it.

-  **Transportable.** Full load lifting eyes, forklift pockets and internal baffles designed to allow handling of the tank full of fuel.
-  **Stackable.** Easily stackable (2)-high full of fuel and (3)-high empty to reduce storage space requirements.
-  **Accessible.** Access manway for maintenance and inspection of inner tank. Removable inner tank for servicing and cleaning.
-  **Efficient.** ENVIROconnect Equipment Cabinet locks and secures equipment and fuel ports to run up to 3 pieces of diesel-powered equipment.
-  **Environmentally Safe.** Double-walled, 110% containment eliminates the need for spill pans, UL 142 approved.

## SPECIFICATION

STANDARD FITTINGS:	High accuracy contents gauge; 3" Fill Point; 2" fusible link fill port; 1" pump feed with flexible dip pipe, strainer & non-return valve; (1) engine feed and return port set; pressure/vacuum vent; breather vent.		
OPTIONAL EQUIPMENT:	Complete transfer pump kits; water & particulate filter kits; fuel up to (2) feed & return blocks; fuel hose & quick couplers.		
Capacity (brim full) Litres:	1,000	Bund Material Thickness (in):	1/8"
Capacity (brim full) Gallons (UK/US):	264	Inner Tank Material (thickness):	1/8"
Dimension Length (in):	46"	Weight Empty (Lbs):	1,118 lbs
Dimension Width (in):	46"	Weight Laden (Lbs):	2,994 lbs
Dimension Height (in):	52"	Design Approvals:	UL142, UN IBC Type 31A, US DOT
Dimension Cabinet Opening:	33½"W x 14" H		

IF IN DOUBT ASK

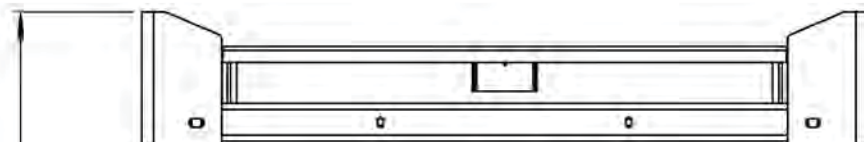

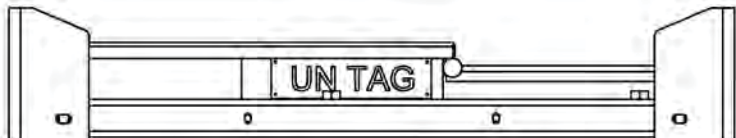
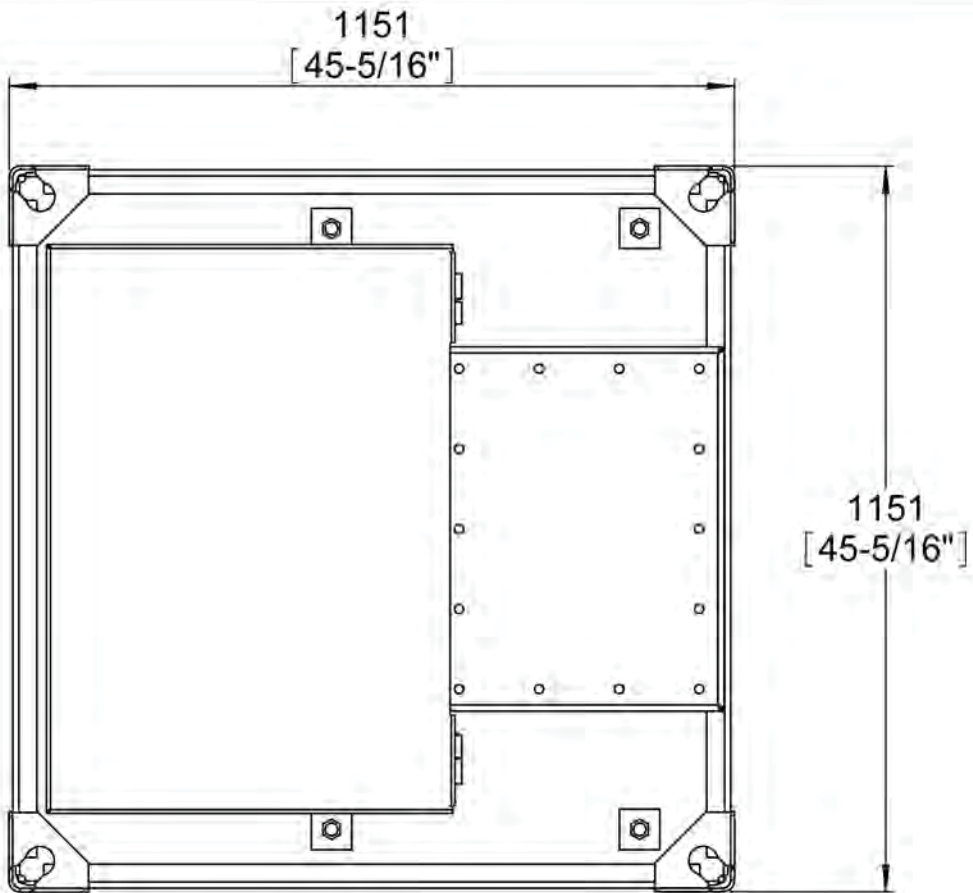

1318  
[51-7/8"]

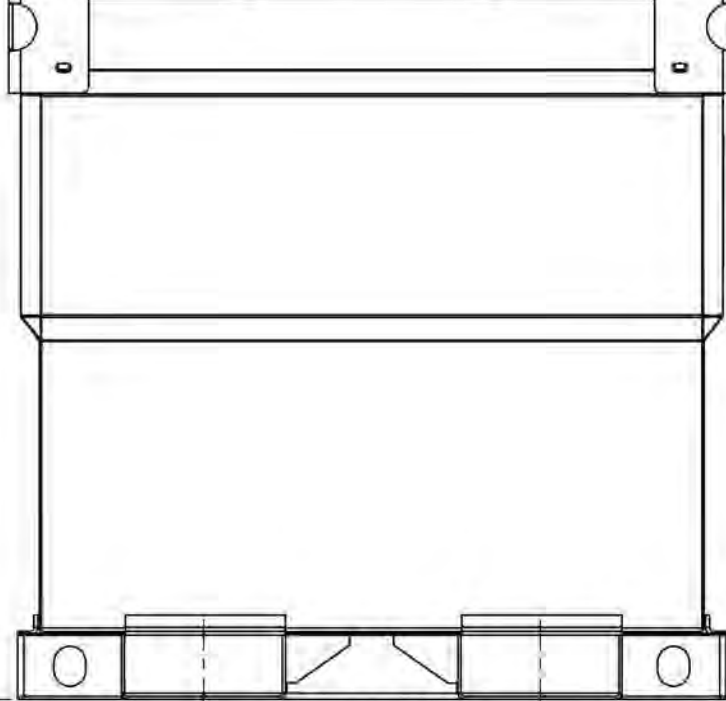

534  
[21"]

**REVISIONS**



WEST

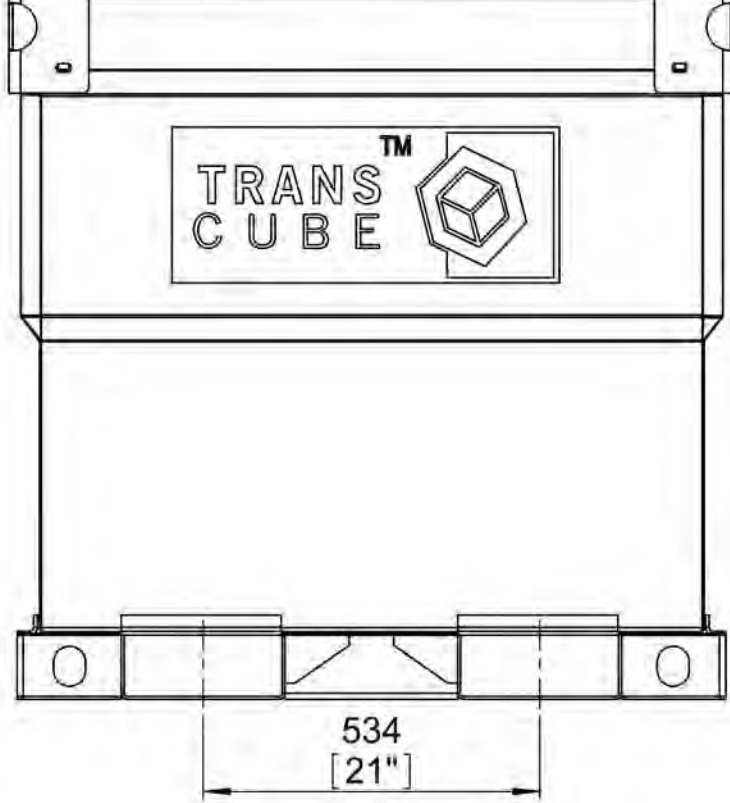

**SCALE**  
**1:12**

WESTERN INTERNATIONAL, INC. 290 QUARRY ROAD MILFORD, CT 06460  TEL: +1 203 847 4300 Email: info@western.us.com www.western-intl.com	<b>MATERIAL</b>		<b>THICKNESS</b>	<b>WEIGHT</b>	<b>DATE</b>
	SEE INDIVIDUAL PARTS		SEE INDIVIDUAL PARTS	497 kg	1/27/2012
	<b>DRAWN</b>	<b>TITLE</b> MAIN ASSEMBLY			
	<b>DRAWING No</b> 10TCG SALES DRAWING			<b>SHEET</b> 1/3	

IF IN DOUBT ASK

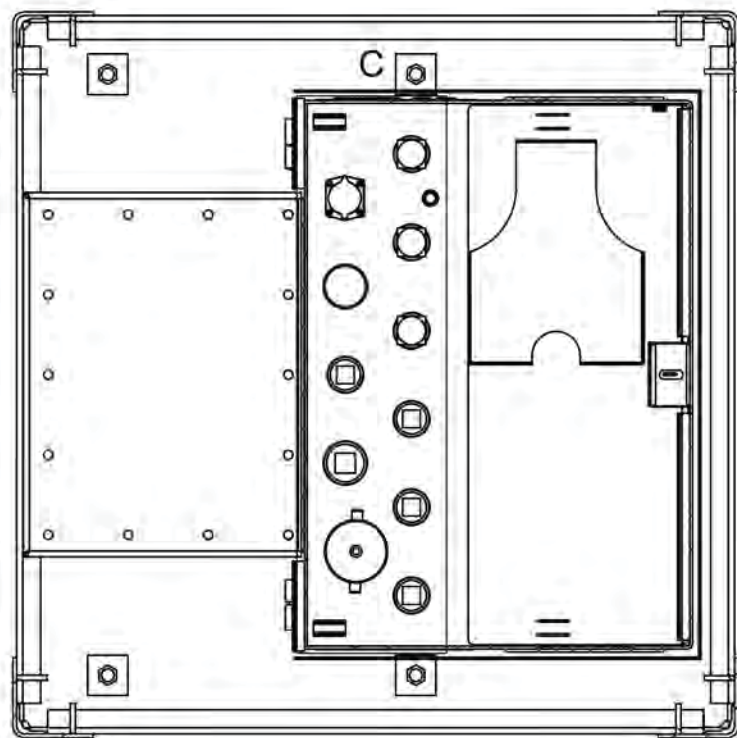

SECTION B-B





1 x GAUGE BRACKET

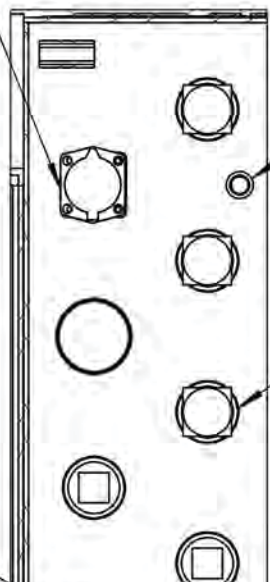

1 x SOCKET 1/4"

7 x SOCKET 1-1/4"

2 x SOCKET 2"



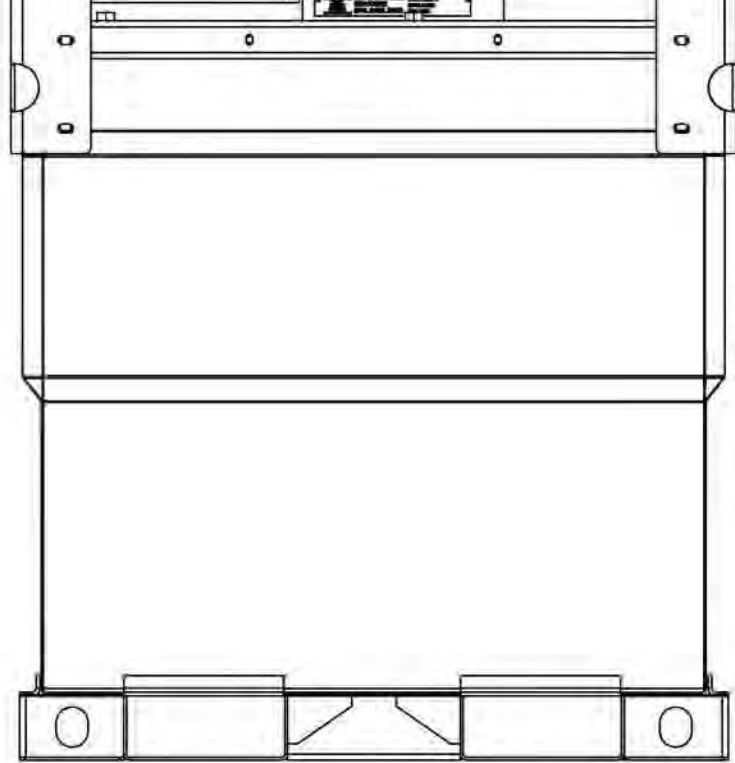

**REVISIONS**

**WESTERN**  
INTERNATIONAL



WEST

1 x3" NPT NIPPLE

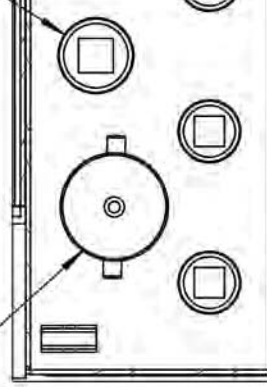

DETAIL C  
SCALE 1 : 7

<b>SCALE</b>
<b>1:12</b>

WESTERN INTERNATIONAL, INC. 290 QUARRY ROAD MILFORD, CT 06460  TEL: +1 203 847 4300 Email: info@western.us.com www.western-intl.com	<b>MATERIAL</b>		<b>THICKNESS</b>	<b>WEIGHT</b>	<b>DATE</b>
	SEE INDIVIDUAL PARTS		SEE INDIVIDUAL PARTS	497 kg	1/27/2012
	<b>DRAWN</b>	<b>TITLE</b> MAIN ASSEMBLY			
	<b>DRAWING No</b> 10TCG SALES DRAWING				<b>SHEET</b> 2/3

IF IN DOUBT ASK

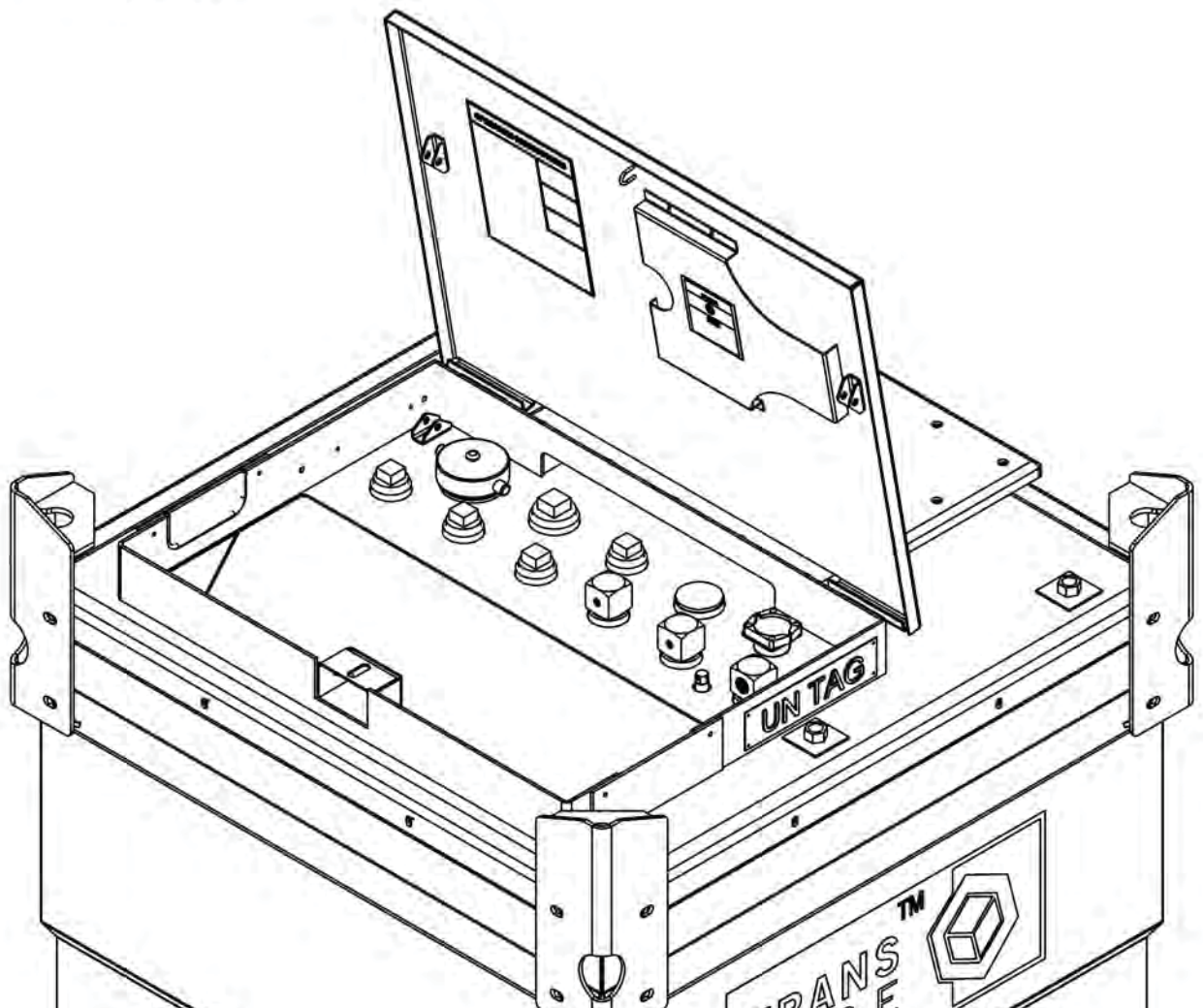

**TANK VOLUME**

**THE USEFUL VOLUME OF THE TANK IS LITRES.**

**5% OF THE TANK VOLUME IS USED FOR THERMAL  
EXPANSION & ULLAGE.**

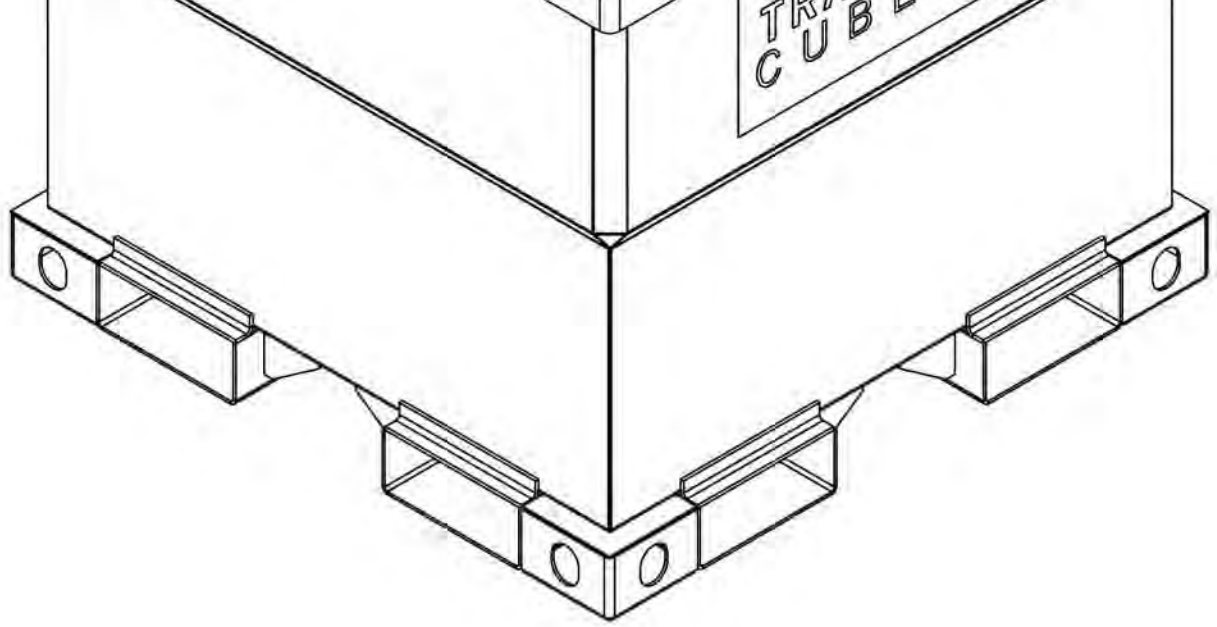

**REVISIONS**

Liquid Volume	Litres/US gal/UK gal
Tank @ 95%	937/248/206
Tank brim Full	986/260/216
Bund (dike) Brim Full	1203/318/265

<b>SCALE</b>
<b>1:10</b>

WESTERN INTERNATIONAL, INC. 290 QUARRY ROAD MILFORD, CT 06460  TEL: +1 203 847 4300 Email: info@western.us.com www.western-intl.com	<b>MATERIAL</b>		<b>THICKNESS</b>	<b>WEIGHT</b>	<b>DATE</b>
	SEE INDIVIDUAL PARTS		SEE INDIVIDUAL PARTS	497 kg	1/27/2012
	<b>DRAWN</b>	<b>TITLE</b> MAIN ASSEMBLY			
	<b>DRAWING No</b> 10TCG SALES DRAWING				<b>SHEET</b> 3/3