

# Core Aerators

CA2560 & CA2572

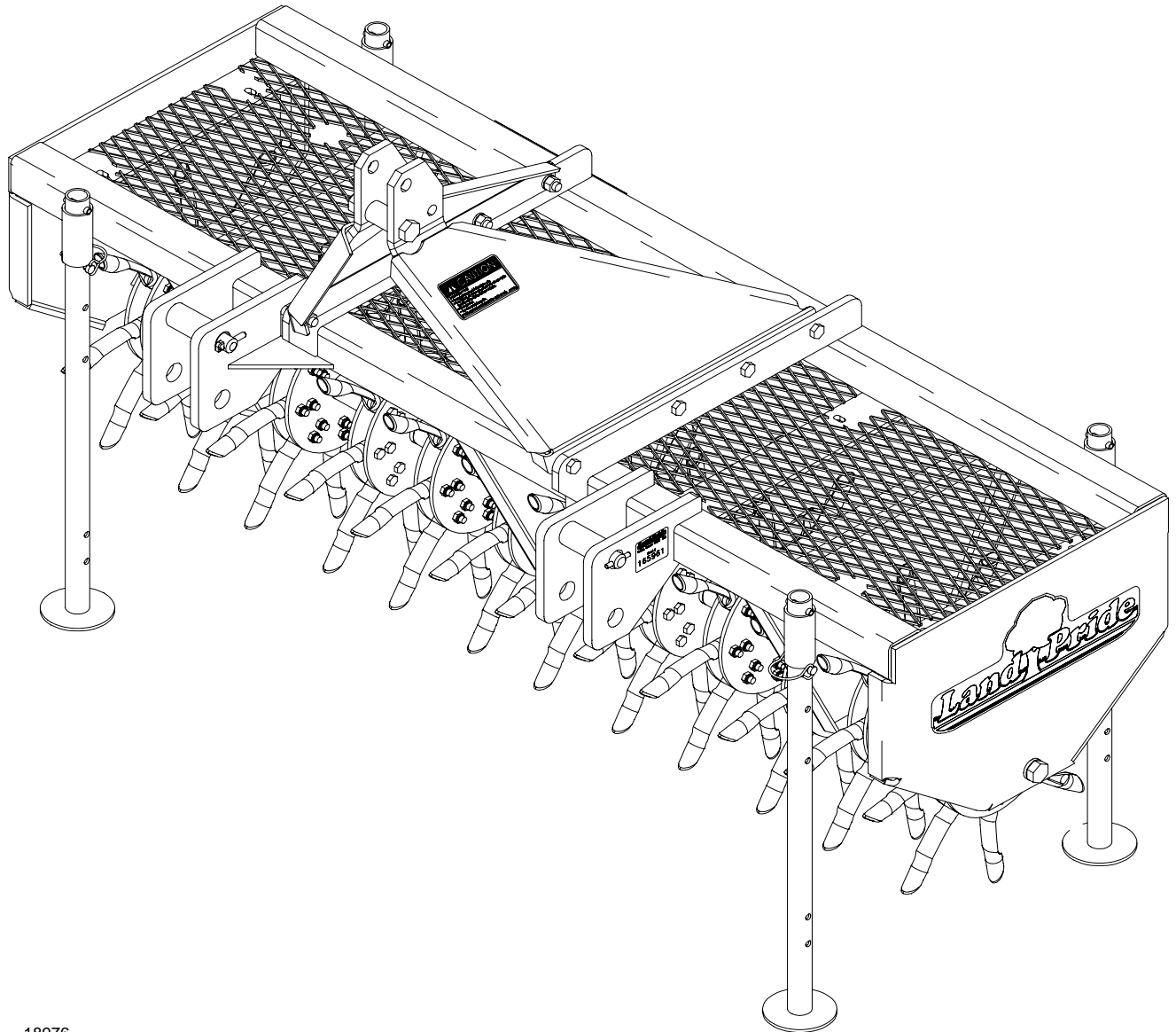

18976

**325-020M**  
**Operator's Manual**



Read the Operator's Manual entirely. When you see this symbol, the subsequent instructions and warnings are serious - follow without exception. Your life and the lives of others depend on it!

**Cover photo may show optional equipment not supplied with standard unit.**

© Copyright 2011 Printed 12/06/11



<b>Important Safety Information</b> . . . . .	<b>1</b>	<b>Section 4: Options</b> . . . . .	<b>14</b>
Safety at All Times . . . . .	1	Weight Tanks . . . . .	14
Look For The Safety Alert Symbol . . . . .	1	<b>Section 5: Maintenance and Lubrication</b>	<b>15</b>
Safety Labels . . . . .	4	Maintenance . . . . .	15
<b>Introduction</b> . . . . .	<b>5</b>	General . . . . .	15
Application . . . . .	5	Cleaning the Spoons . . . . .	15
Using This Manual . . . . .	5	Lubrication . . . . .	15
Terminology . . . . .	5	Rotor . . . . .	15
Definitions . . . . .	5	<b>Section 6: Specifications &amp; Capacities</b>	<b>16</b>
Owner Assistance . . . . .	5	<b>Section 7: Features &amp; Benefits</b> . . . . .	<b>17</b>
Serial Number . . . . .	5	<b>Section 8: Troubleshooting</b> . . . . .	<b>18</b>
Further Assistance . . . . .	6	<b>Section 9: Torque Values Chart</b> . . . . .	<b>19</b>
<b>Section 1: Assembly and Set-Up</b> . . . . .	<b>7</b>	<b>Section 10: Warranty</b> . . . . .	<b>21</b>
General Description . . . . .	7		
Tools Required . . . . .	7		
Unloading Instructions . . . . .	7		
Torque Requirements . . . . .	7		
Assembly Instructions . . . . .	7		
Hitch Assembly . . . . .	7		
Optional Weight Tanks . . . . .	8		
<b>Section 2: Adjustments</b> . . . . .	<b>9</b>		
Parking Stands . . . . .	9		
Storage Position Without Added Weight . . . . .	9		
Storage Position With Added Weight . . . . .	9		
Working Position . . . . .	9		
<b>Section 3: Operating Instructions</b> . . . . .	<b>10</b>		
Pre-Start Checklist . . . . .	10		
Operator Safety . . . . .	10		
Equipment Safety . . . . .	10		
Tractor Hook-Up . . . . .	11		
Quick Hitch Hook-Up . . . . .	11		
Leveling Adjustments . . . . .	12		
Transporting . . . . .	12		
Un-hooking Core Aerator . . . . .	12		
Storage . . . . .	12		
General Operation Instructions . . . . .	13		



© Copyright 2011 All rights Reserved

Land Pride provides this publication "as is" without warranty of any kind, either expressed or implied. While every precaution has been taken in the preparation of this manual, Land Pride assumes no responsibility for errors or omissions. Neither is any liability assumed for damages resulting from the use of the information contained herein. Land Pride reserves the right to revise and improve its products as it sees fit. This publication describes the state of this product at the time of its publication, and may not reflect the product in the future.

Land Pride is a registered trademark.

All other brands and product names are trademarks or registered trademarks of their respective holders.

Printed in the United States of America.

**Important Safety Information**

These are common practices that may or may not be applicable to the products described in this manual.

**Safety at All Times**

Thoroughly read and understand the instructions given in this manual before operation. Refer to the "Safety Label" section, read all instructions noted on them.

Do not allow anyone to operate this equipment who has not fully read and comprehended this manual and who has not been properly trained in the safe operation of the equipment.

- ▲ Operator should be familiar with all functions of the unit.
- ▲ Operate implement from the driver's seat only.
- ▲ Make sure all guards and shields are in place and secured before operating implement.
- ▲ Do not leave tractor or implement unattended with engine running.
- ▲ Dismounting from a moving tractor could cause serious injury or death.
- ▲ Do not allow anyone to stand between tractor and implement while backing up to implement.
- ▲ Keep hands, feet, and clothing away from power-driven parts.
- ▲ Wear snug fitting clothing to avoid entanglement with moving parts.
- ▲ Watch out for wires, trees, etc., when raising implement. Make sure all persons are clear of working area.
- ▲ Turning tractor too tight may cause implement to ride up on wheels. This could result in injury or equipment damage.
- ▲ Do not carry passengers on implement at any time.

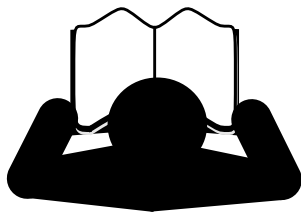

**Look For The Safety Alert Symbol**

The SAFETY ALERT SYMBOL indicates there is a potential hazard to personal safety involved and extra safety precaution must be taken. When you see this symbol, be alert and carefully read the message that follows it. In addition to design and configuration of equipment, hazard control and accident prevention are dependent upon the awareness, concern, prudence and proper training of personnel involved in the operation, transport, maintenance and storage of equipment.

**Be Aware of Signal Words**

A Signal word designates a degree or level of hazard seriousness. The signal words are:

**⚠ DANGER**  
Indicates an imminently hazardous situation which, if not avoided, will result in death or serious injury. This signal word is limited to the most extreme situations, typically for machine components that, for functional purposes, cannot be guarded.

**⚠ WARNING**  
Indicates a potentially hazardous situation which, if not avoided, could result in death or serious injury, and includes hazards that are exposed when guards are removed. It may also be used to alert against unsafe practices.

**⚠ CAUTION**  
Indicates a potentially hazardous situation which, if not avoided, may result in minor or moderate injury. It may also be used to alert against unsafe practices.

**For Your Protection**

- ▲ Thoroughly read and understand the "Safety Label" section, read all instructions noted on them.

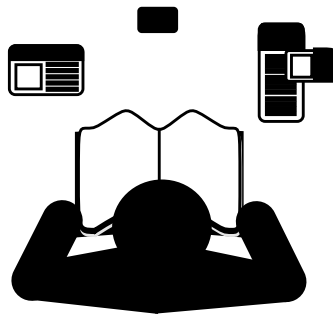

**Shutdown and Storage**

- ▲ Lower machine to ground, put tractor in park, turn off engine, and remove the key.
- ▲ Detach and store implements in a area where children normally do not play. Secure implement by using blocks and supports.

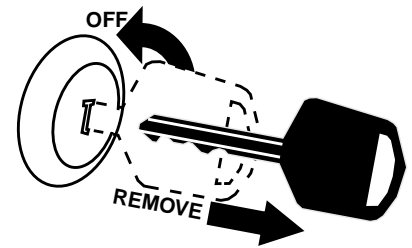

**Parts Manual QR Locator**

The QR (Quick Reference) code on the front cover and to the left will take you to the Parts Manual for this equipment. Download the appropriate App on your smart phone, open the App, point your phone on the QR code and take a picture.



**Dealer QR Locator**

The QR code on the left will link you to available dealers for Land Pride products. Refer to Parts Manual QR Locator on this page for detailed instructions.

These are common practices that may or may not be applicable to the products described in this manual.

### Use Safety Lights and Devices

- ▲ Slow moving tractors, self-propelled equipment, and towed implements can create a hazard when driven on public roads. They are difficult to see, especially at night.
- ▲ Flashing warning lights and turn signals are recommended whenever driving on public roads.

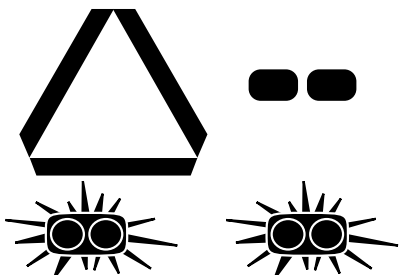

### Transport Machinery Safely

- ▲ Comply with state and local laws.
- ▲ Maximum transport speed for implement is 20 mph. **DO NOT EXCEED.** Never travel at a speed which does not allow adequate control of steering and stopping. Some rough terrain require a slower speed.
- ▲ Sudden braking can cause a towed load to swerve and upset. Reduce speed if towed load is not equipped with brakes.
- ▲ Use the following maximum speed - tow load weight ratios as a guideline:
  - 20 mph** when weight is less than or equal to the weight of tractor.
  - 10 mph** when weight is double the weight of tractor.
- ▲ **IMPORTANT:** Do not tow a load that is more than double the weight of tractor.

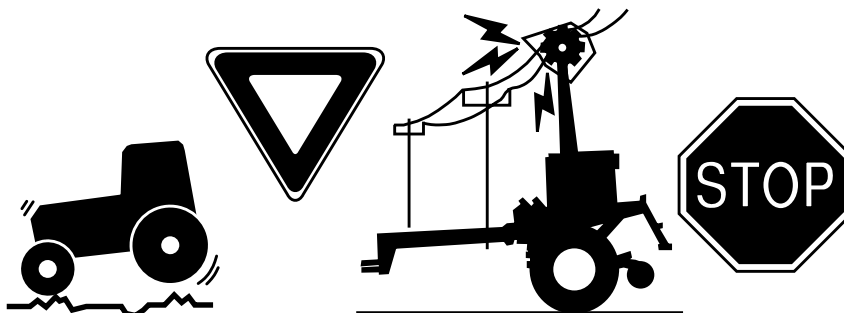

### Use A Safety Chain

- ▲ A safety chain will help control drawn machinery should it separate from the tractor drawbar.
- ▲ Use a chain with the strength rating equal to or greater than the gross weight of the towed machinery.
- ▲ Attach the chain to the tractor drawbar support or other specified anchor location. Allow only enough slack in the chain to permit turning.
- ▲ Do not use safety chain for towing.

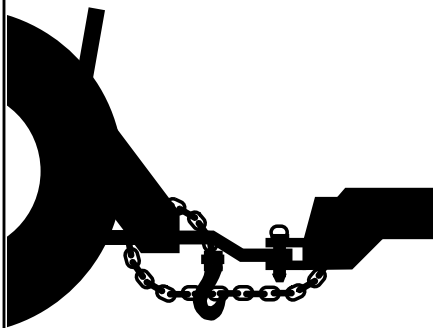

### Practice Safe Maintenance

- ▲ Understand procedure before doing work. Use proper tools and equipment, refer to Operator's Manual for additional information.
- ▲ Work in a clean dry area.
- ▲ Lower the implement to the ground, put tractor in park, turn off engine, and remove key before performing maintenance.
- ▲ Allow implement to cool completely.
- ▲ Do not grease or oil implement while it is in operation.
- ▲ Inspect all parts. Make sure parts are in good condition & installed properly.
- ▲ Remove buildup of grease, oil or debris.
- ▲ Remove all tools and unused parts from implement before operation.



**Important Safety Information**

These are common practices that may or may not be applicable to the products described in this manual.

**Prepare for Emergencies**

- ▲ Be prepared if a fire starts.
- ▲ Keep a first aid kit and fire extinguisher handy.
- ▲ Keep emergency numbers for doctor, ambulance, hospital and fire department near phone.

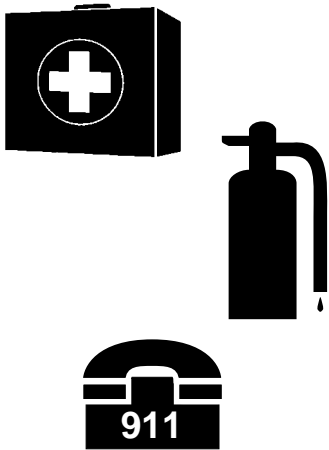

**Wear Protective Equipment**

- ▲ Wear protective clothing and equipment appropriate for the job. Avoid loose fitting clothing.
- ▲ Prolonged exposure to loud noise can cause hearing impairment or hearing loss. Wear suitable hearing protection such as earmuffs or earplugs.
- ▲ Operating equipment safely requires the full attention of the operator. Avoid wearing radio headphones while operating machinery.



**Keep Riders Off Machinery**

- ▲ Riders obstruct the operator's view they could be struck by foreign objects or thrown from the machine.
- ▲ Never allow children to operate equipment.

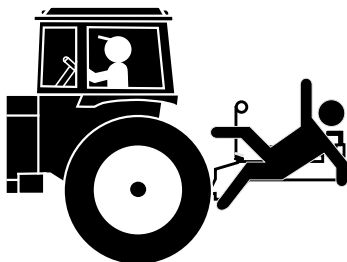

**Avoid High Pressure Fluids Hazard**

- ▲ Escaping fluid under pressure can penetrate the skin causing serious injury.
- ▲ Avoid the hazard by relieving pressure before disconnecting hydraulic lines or performing work on the system.
- ▲ Make sure all hydraulic fluid connections are tight and all hydraulic hoses and lines are in good condition before applying pressure to the system.
- ▲ Use a piece of paper or cardboard, NOT BODY PARTS, to check for suspected leaks.
- ▲ Wear protective gloves and safety glasses or goggles when working with hydraulic systems.
- ▲ If an accident occurs, see a doctor immediately. Any fluid injected into the skin must be treated within a few hours or gangrene may result.



## Important Safety Information

### Safety Labels

Your Core Aerator comes equipped with all safety labels in place. They were designed to help you safely operate your implement. Read and follow their directions.

1. Keep all safety labels clean and legible.
2. Replace all damaged or missing labels. To order new labels go to your nearest Land Pride dealer or visit our dealer locator at [landpride.com](http://landpride.com).
3. Some new equipment installed during repair require safety labels to be affixed to the replaced component as specified by Land Pride. When ordering new components make sure the correct safety labels are included in the request. To order new labels go to your Land Pride Dealer.

4. Refer to this section for proper label placement.  
To install new labels:
  - a. Clean the area the label is to be placed.
  - b. Spray soapy water on the surface where the label is to be placed.
  - c. Peel backing from label. Press firmly onto the surface.
  - d. Squeeze out air bubbles with the edge of a credit card.

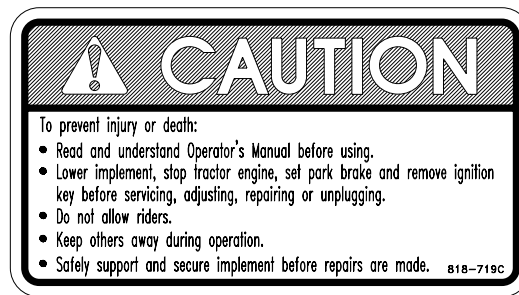
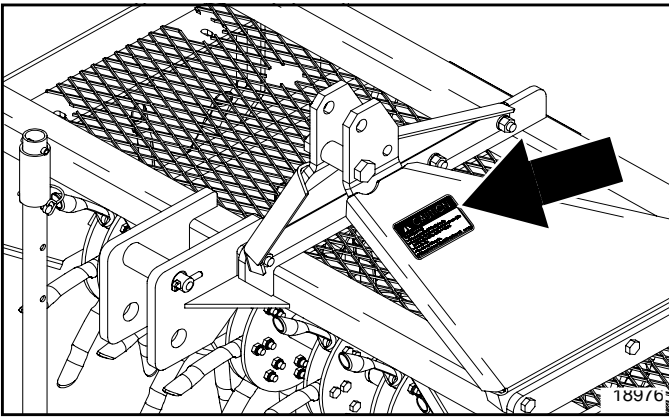

**818-719C**

General Caution Decal



## Introduction

Land Pride welcomes you to the growing family of new product owners.

This Core Aerator has been designed with care and built by skilled workers using quality materials. Proper assembly, maintenance, and safe operating practices will help you get years of satisfactory use from the Aerator.

## Application

The Land Pride 25 Series Core Aerators are designed for Category 1 - three-point hitch or Quick-Hitch System mounting. The 25 Series Core Aerators are adapted for attachment to tractors capable of properly lifting, lowering, and transporting up to 1200 lbs. on the three-point hitch. These Aerators come in 60" and 72" working widths.

The 25 Series Core Aerators are designed to relieve soil compaction and allow air circulation in grassy surfaces such as lawns, soccer fields, football fields, baseball fields, municipal parks, and golf course fairways. The 25 series Aerators utilize replaceable case hardened closed spoons mounted on weighted rotating discs. These spoons pull cores up to 3" in length from the soil profile every 7" of forward travel. The lateral gang spacing on the CA256 is 5 1/2" and 6 1/2" on the CA2572. Pulled cores are deposited on the surface for subsequent drying, pulverization, or removal. In order to achieve maximum penetration the CA2560 & CA2572 offer optional poly water tanks that fit in the top mounted weight trays. When filled with water these tanks provide significantly increased down pressure on the spoons.

When your turf begins to suffer the effects of compaction and wear, such as shallow root zones, thatch build-up, worn pathways, rock hard ground, poor surface percolation, or water stands, a Land Pride 25 Series Core Aerator will help provide seasonal relief.

See "**Specifications & Capacities**" on page 16 and "**Features & Benefits**" on page 17 for additional information and performance enhancing options.

## Using This Manual

- This Operator's Manual is designed to help familiarize you with safety, assembly, operation, adjustments, troubleshooting, and maintenance. Read this manual and follow the recommendations to help ensure safe and efficient operation.
- The information contained within this manual was current at the time of printing. Some parts may change slightly to assure you of the best performance.
- To order a new Operator's or Parts Manual contact your authorized dealer. Manuals can also be downloaded, free-of-charge from our website at [www.landpride.com](http://www.landpride.com).

## Terminology

"Right" or "Left" as used in this manual is determined by facing the direction the machine will operate while in use unless otherwise stated.

## Definitions

**IMPORTANT:** A special point of information related to the following topic. Land Pride's intention is this information must be read & noted before continuing.

**NOTE:** A special point of information that the operator should be aware of before continuing.

## Owner Assistance

The Warranty Registration card should be filled out by the dealer at the time of purchase. This information is necessary to provide you with quality customer service.

If customer service or repair parts are required contact a Land Pride Dealer. A dealer has trained personnel, repair parts and equipment needed to service the implement.

The parts on your CA25 Series Core Aerator have been specially designed and should only be replaced with genuine Land Pride parts. Therefore, should your Aerator require replacement parts go to your Land Pride Dealer.

## Serial Number

Model No. \_\_\_\_\_ Serial No. \_\_\_\_\_

For quick reference and prompt service, record model number and serial number in the spaces provided above and again on warranty page 19. Always provide model number and serial number when ordering parts and in all correspondences with your Land Pride dealer. Refer to Figure 1 for location of your serial number plate.

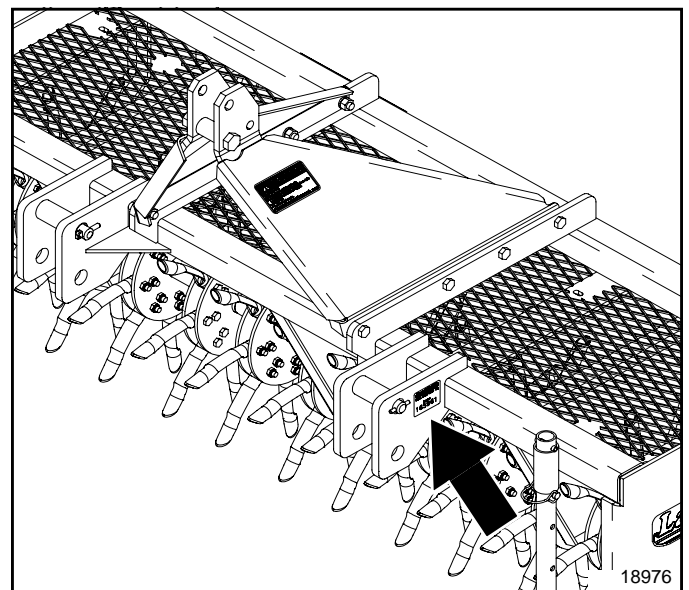

Serial Number Plate Location  
Figure 1

### Further Assistance

Your dealer wants you to be satisfied with your new Core Aerator. If for any reason you do not understand any part of this manual or are not satisfied with the service received, the following actions are suggested:

1. Discuss the matter with your dealership service manager making sure he is aware of any problems you may have and that he has had the opportunity to assist you.
2. If you are still not satisfied, seek out the owner or general manager of the dealership, explain the problem and request assistance.
3. For further assistance write to:

**Land Pride Service Department**

**1525 East North Street**

P.O. Box 5060

Salina, Ks. 67402-5060

E-mail address

[lp servicedept@landpride.com](mailto:lp servicedept@landpride.com)



## Section 1: Assembly and Set-Up

### General Description

This unit is shipped partially assembled. It is the Dealerships responsibility to finish the assembly.

### Tools Required

- Lift truck or hoist capable of handling the load
- Wrench set
- Socket set

### Unloading Instructions



### CAUTION

*Never allow anyone under the unit while unloading.*

Remove crated Aerator from the flat bed trailer with a lifting devise designed for handling the load. Gently set the crate down on a smooth flat work surface. Carefully uncrate the unit to protect against scratching and/or damaging the paint.

### Torque Requirements

Refer to “Torque Values Chart For Common Bolt Size” on page 19 to determine correct torque values when tightening hardware.

### Assembly Instructions

Review all safety instructions printed in this manual before assembling the Aerator.

**NOTE:** Do not tighten the hardware until assembly is complete.

### Hitch Assembly

*Refer to Figure 1-1:*

1. Install upper hitches (#1) & (#2) to frame using 1/2" x 1 1/2" bolts (#3), lockwashers (#4) & nuts (#5).
2. Install bushing (#6) between upper hitches with 3/4" x 4" long bolt (#7), lockwasher (#8) and nut (#9).
3. Tighten all hardware using torque requirements on page 19.

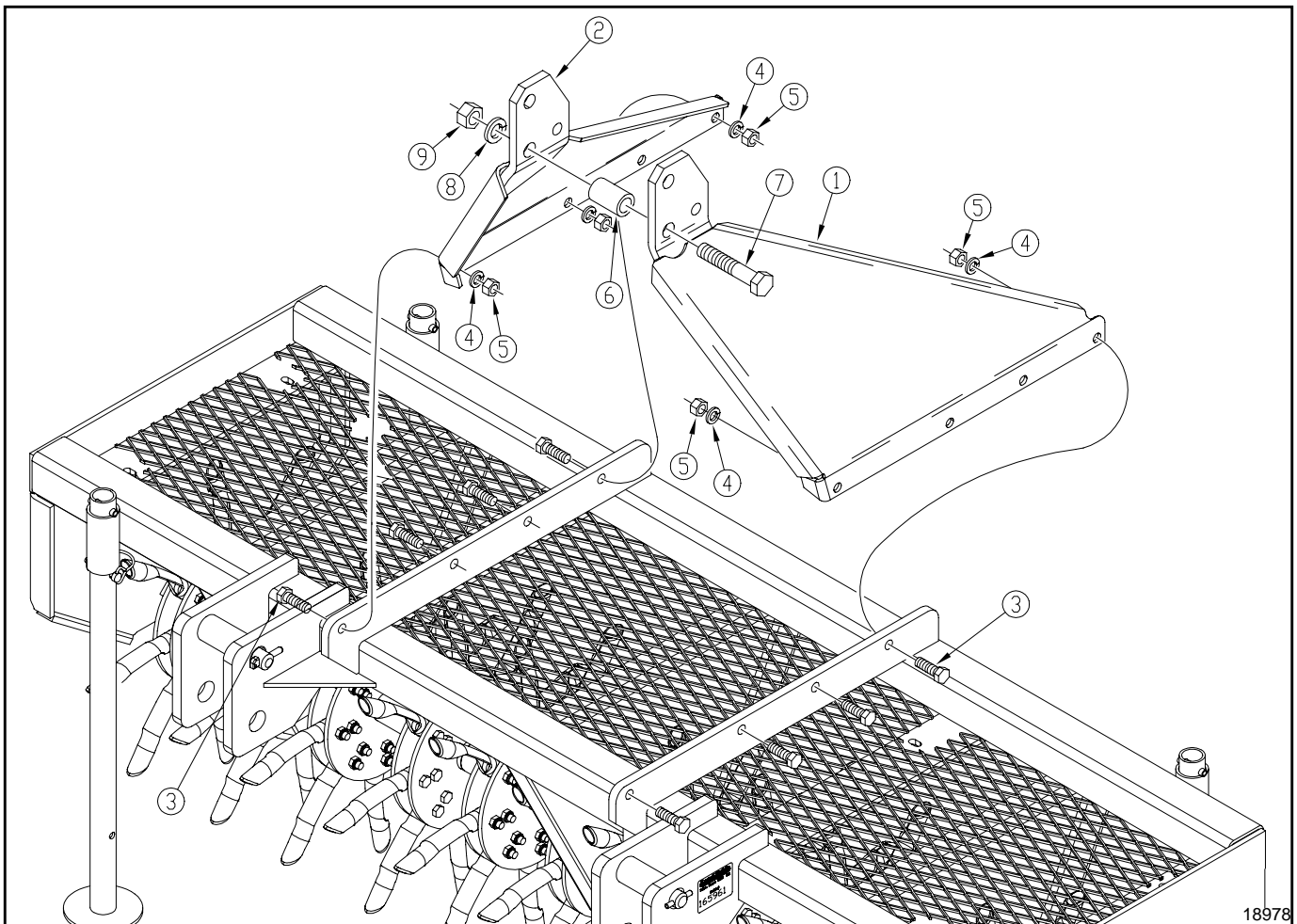

**Hitch Assembly  
Figure 1-1**

## Section 1: Assembly and Set-Up

### Optional Weight Tanks

**IMPORTANT:** You could lose steering control if your tractor is too light. Refer to your tractor's manual to determine if additional ballast is needed.

**Refer to Figure 1-2:**

Additional weight may be added to Models CA2560 and CA2572 Core Aerators with weight tanks that can be filled with water.

1. Attach water tanks (#2) to Aerator frame with 3/8"-16 x 1" GR5 cap screws (#6), lock washers (#5) and flat washers (#4). Tighten bolts to the correct torque.
2. Make sure vented caps (#1) and drain plugs (#3) are screwed on tight to the weight tanks.

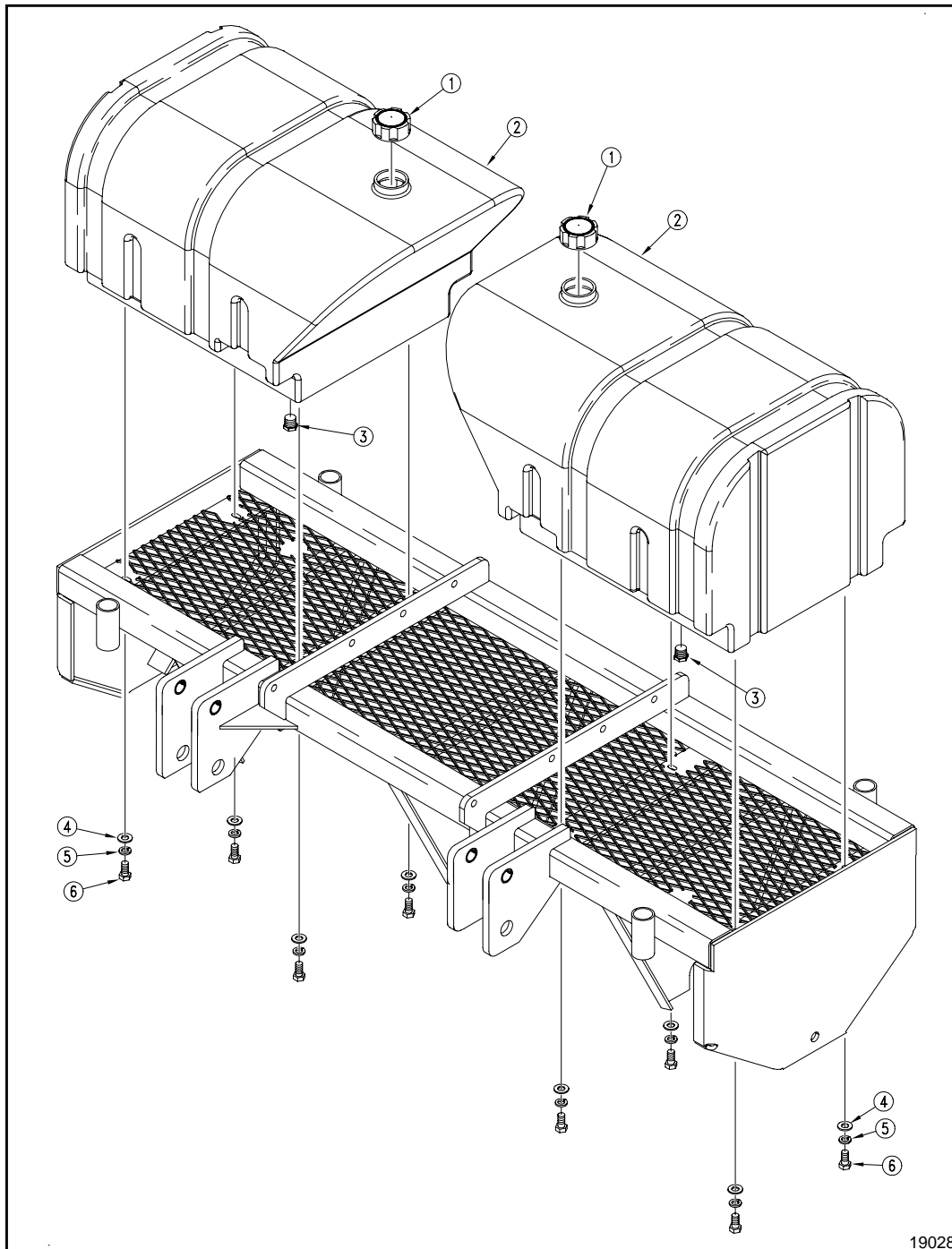

19028

**Water Tanks Option  
Figure 1-2**

Section 2: Adjustments

**Parking Stands**

**Storage Position Without Added Weight**

Refer to Figure 2-1:

Parking stands may be adjusted fully down so that the Core Aerator spoons are supported above ground as shown in Figure 2-1. Use this position only when parking the Core Aerator without weight added to the unit.

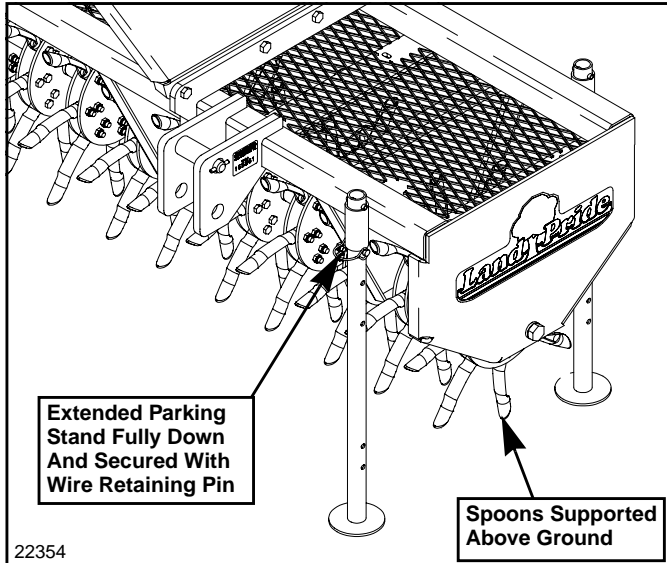

Parking Stand Un-hooked Position without added weights  
Figure 2-1

**Storage Position With Added Weight**

Refer to Figure 2-2:

If weight has been added to the unit, the parking stands must be adjusted so that the Aerator spoons rest on level ground as shown in Figure 2-2.

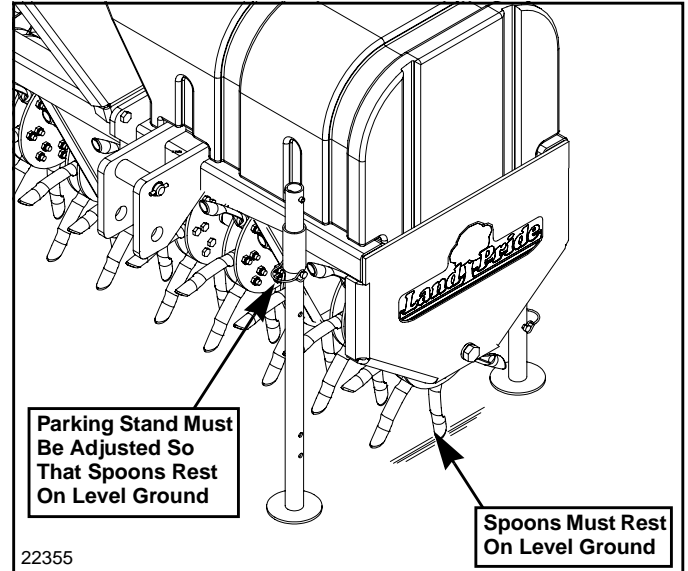

Parking Stand Un-hooked Position with added weights  
Figure 2-2

**Working Position**

Refer to Figure 2-3:

The four parking stands should be fully raised for working and while transporting.

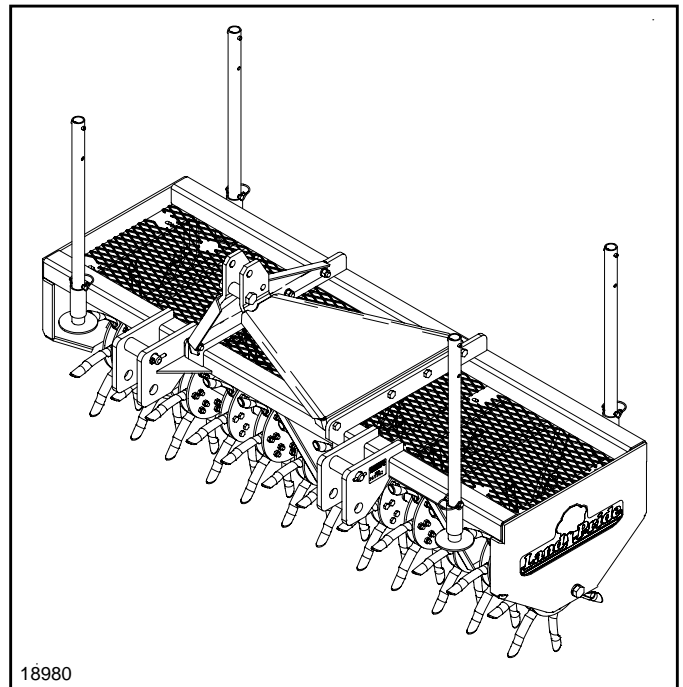

Parking Stand Working Position  
Figure 2-3

Section 3: Operating Instructions

**Pre-Start Checklist**

Hazard control and accident prevention are dependent upon the awareness, concern, prudence and proper training involved in the operation, transport, maintenance and storage of the Core Aerator. Therefore, it is absolutely essential that no one operates the Aerator without first having read, fully understood and become totally familiar with the Operator's Manual. Make sure the operator has completed the Operating Checklist below.

**Operating Checklist**

✓	Check	Page No.
	Read and follow all Safety Rules carefully. Refer to "Important Safety Information".	Page 1
	Read and follow all preparation instructions. Refer to "Section 1: Assembly and Set-Up".	Page 7
	Read and make all required adjustments. Refer to "Section 2: Adjustments".	Page 9
	Read and follow Hook-up & all operating procedures. Refer to "Section 3: Operating Instructions".	Page 10
	Read and follow all Maintenance Instructions. Refer to "Section 5: Maintenance and Lubrication".	Page 15
	Read and follow all Lubrication Instructions. Refer to "Lubrication".	Page 15
	Check Aerator initially and periodically for loose bolts and pins. Refer to "Torque Values Chart For Common Bolt Size".	Page 19

**Operator Safety**

**DANGER**

*Operator must age 16 or older and must be properly trained in the safe operation of this Core Aerator.*

**DANGER**

*Operator must wear a seat belt at all times. Without being seat belted, the operator could fall off and be ran over by the Aerator and its sharp spoon.*

**DANGER**

*Never carry passengers on the Core Aerator or tractor and never operate the unit when bystanders are present. There is always a risk of running over the passenger or bystander.*

**DANGER**

*Always keep your feet and legs out from under the Core Aerator and never work under the unit without properly blocking it up. The Aerator could drop instantly resulting in bodily injury or death.*

**DANGER**

*Do not operate on slopes too steep to maintain stability or near the edge of a drop off. The tractor and Aerator could roll over resulting in equipment damage, bodily injury or death.*

**DANGER**

*Do not work over any underground electrical wiring or gas lines. If there is any doubt, call your public service agency. Be sure to ask how close you can work to their flags or marks. Making contact with electrical wiring or gas pipes can cause serious injury or death.*

**WARNING**

*Never pull the Core Aerator behind a vehicle at high speeds. High speeds can cause the tires to break resulting in loss of control.*

**CAUTION**

*Make sure all safety labels are in their proper location and in good working condition before operation. Be sure to follow all directions on the safety labels.*

**Equipment Safety**

1. Use Core Aerator for its intended purpose only. Never use it as a wagon to carry things. Never pull or tow other equipment or objects. Never pull post, stumps or other objects. Misuse of the Core Aerator can break the unit.
2. Mark underground water piping, sprinkler heads, sizable rocks and other objects that can be damage or cause damage to the Aerator with small warning flags so they can be avoided.
3. Do not exceed the weight tray weight limit. Exceeding the limit can damage the spoon, tires and Aerator frame.
4. Make gradual turns with spoon in the ground. Too sharp a turn can break the spoon.
5. Do not turn tractor tires into the tongue, spoon or frame. Slow down and watch tractor tires carefully when forced to make sharp turns.
6. Working speeds in excess of 5 mph can damage the spoon and frame.
7. Do not use spoon to tear up asphalt or for anything other than to aerate soil.
8. If the area being worked has a sprinkler system, locate and mark sprinkler heads with warning flags so they can be avoided.
9. Do not alter Core Aerator in a way which will adversely affect its performance or reliability or use the unit for a purpose for which it was not designed.

## Section 3: Operating Instructions

### Tractor Hook-Up



#### DANGER

A *Crushing Hazard* exists when hooking-up equipment to a tractor. **Do not** allow anyone to stand between tractor and implement while backing-up to implement. **Do not** operate hydraulic 3-point lift controls while someone is directly behind the tractor or near the implement.



#### CAUTION

Always make sure the hitch pin is secured with a keeper clip. Not doing so can result in the unit coming unhitched and out of control.



#### CAUTION

Always engage parking brake, shut off tractor and remove key before dismounting from tractor to hook-up equipment.

**IMPORTANT:** You could lose steering control if your tractor is too light. Refer to your tractor's manual to determine if additional ballast is needed.

#### Refer to Figure 2-1:

1. If installed, remove 3-point stabilizing equipment to allow Aerator to float over the ground and to help reduce side loading on the spoons.
2. Move drawbar fully forward. (Towards front of tractor)
3. Slowly back tractor up to Core Aerator until tractor's lower 3-point links are aligned with Aerator's lower hitch clevises.

**NOTE:** Supplied with the Core Aerator are two lower bushing for hooking-up to the implement with a Quick-hitch. Do not use the lower bushings when connecting directly to the tractor's 3-point arms.

4. Secure tractor's 3-point lower links to the lower hitch clevises as follows:

#### Standard Tractors

Attach 3-point lower arms to the upper clevis holes with 7/8" diameter hitch pins. (7/8" hitch pins are furnished with Aerator.)

#### Compact Tractors

Attach 3-point lower arms to the lower clevis holes with 7/8" diameter hitch pins. (7/8" hitch pins are furnished with Aerator.)

5. Secure tractor's top center link to the Aerator's top hitch using a 3/4" diameter hitch pin. (3/4" top hitch pin is supplied by customer.)
6. Raise park stands up and secure in working position. See "Parking Stands" on page 9
7. Return to the tractor and slowly operate controls up and down to check for clearance between Core Aerator, tractor tires, frame and drawbar. Move or remove drawbar if it interferes with Aerator.

### Quick Hitch Hook-Up

#### Refer to Figure 3-1 on page 11:

Land Pride's Model QH15 Quick hitch fits the Core Aerator's Cat. I hitch. If using a compact tractor that cannot lift the Aerator high enough for transport, move 7/8" hitch pins and Quick Hitch bushing to the lowest holes in the 3-point clevises. The Upper J-hook of the Quick Hitch will need to be adjusted vertically to accommodate center hook-up. Other brands that do not have an adjustable J-hook may not fit when using the lowest 3-point hitch holes.

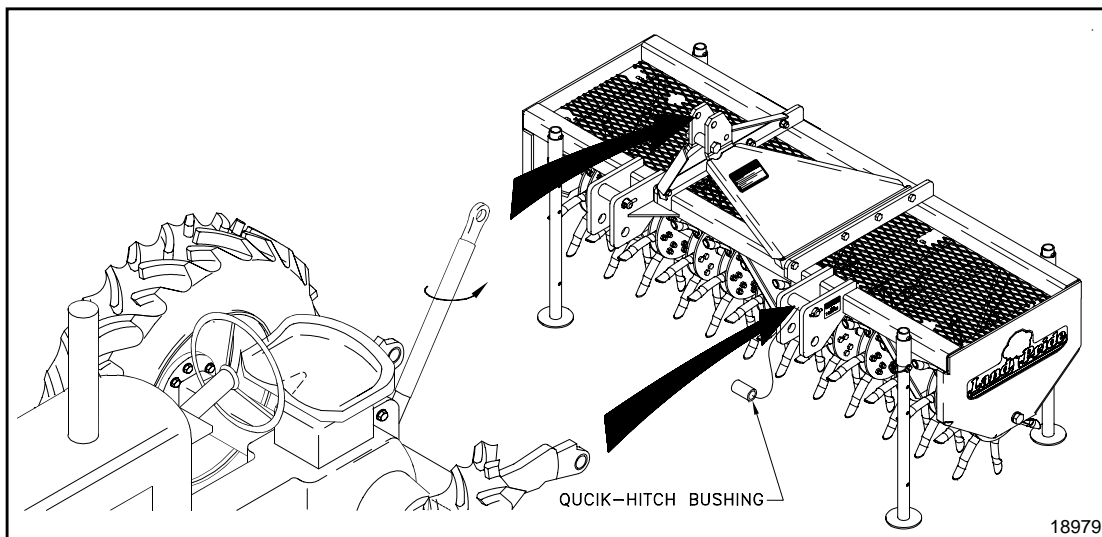

Tractor Hook-Up  
Figure 3-1



## Section 3: Operating Instructions

### Leveling Adjustments

Check for levelness by parking tractor on a level surface and lowering Aerator down until unit is approximately 1 to 2 inches off the ground. Place tractor in park or set park brake, shut tractor off and remove switch key.

**NOTE:** See Tractor Operator's Manual for instructions on how to adjust tractor's lower 3-point arms and top center link.

1. Place a level on the front mainframe tube. Level mainframe from left to right by adjusting one of the tractor's lower 3-point arms up or down.
2. Without starting the tractor, lower tractor's 3-point hitch until all weight is off of tractor.
3. Rotate level 90 degrees and place across end of mainframe. Adjust tractor's top center link until mainframe is level from front to back.

### Transporting



#### CAUTION

*When traveling on public roads at night or during the day, use accessory lights and devices for adequate warning to operators of other vehicles. Comply with all federal, state and local laws.*

1. Select a safe ground speed when transporting from one area to another.
2. Be sure to reduce tractor ground speed when turning and leave enough clearance so the equipment does not contact obstacles such as buildings, trees or fences.
3. Always raise Core Aerator up before traveling on public roadways.
4. When traveling on roadways, transport in such a way that faster moving vehicles may pass you safely.
5. Shift to a lower gear when traveling over rough or hilly terrain.

### Un-hooking Core Aerator

The following steps should be done when un-hooking Core Aerator from the tractor:

1. Park tractor and Core Aerator on a solid level surface. Lower Aerator until approximately 6" off the ground. Place tractor in park or set park brake, shut tractor off and remove switch key.
2. See "**Parking Stands**" on page 9 for information on adjusting them to the correct height. Lower parking stands to the correct height and make sure wire retaining pins are secured in place.
3. Without starting tractor, lower tractor's 3-point hitch until all weight is off of tractor.
4. Remove center hitch pin. Store hitch pin in a safe location for reuse.
5. Remove lower hitch pins. Store lower hitch pins in lower clevises for reuse.
6. Be sure implement is clear of tractor and then drive tractor away from implement.

### Storage

Clean, inspect, service and make necessary repairs to the Core Aerator when parking it for long periods and when parking it at the end of a working season. This will help ensure that the Aerator is ready for field use next time you hook-up to it.

1. Clean off any dirt and grease that may have accumulated on the Core Aerator. Scrape off compacted dirt. Clean out cores lodged in the spoon. See "**Cleaning the Spoons**" on page 15.
2. When finished cleaning and scraping dirt and grease off, wash the surfaces thoroughly with a garden hose.
3. Repaint parts where paint is worn or scratched to prevent rust. A coating of oil may also be applied to the spoon to minimize oxidation.
4. Replace all damaged or missing decals.
5. Store the Core Aerator inside if possible. Inside storage will reduce maintenance and make for a longer Aerator life.
6. Inspect Core Aerator for loose, damaged or worn parts and adjust or replace as needed.



## Section 3: Operating Instructions

### General Operation Instructions

By now you should have read your Operator's Manual and properly installed your Land Pride 25 Series Core Aerator on your tractor. If you haven't, please do so now.

Using the Core Aerator is a fairly simple task but there are a few things you need to consider before beginning. If you are aerating in an area that uses a sprinkler system, you will need to mark the sprinkler heads with small warning flags so they can be avoided. Also you will want to avoid any sizable rocks or foreign material that might be embedded in the soil that could cause damage to the aerating spoon. Most important, do not work over underground electrical wiring or gas lines.



#### **DANGER**

*Do not work over any underground electrical wiring or gas lines. If there is any doubt, call your public service agency. Be sure to ask how close you can work to their flags or marks. Making contact with electrical wiring or gas pipes can cause serious injury or death.*

Now that you know where you are going to aerate and what precautions need to be taken, it is time to start the tractor and travel to the site where you intend to aerate. It is best to start in the middle of the field and gradually work your way to the outer perimeter with each pass. This will also help keep you from compressing freshly pulled cores.

Begin by lowering the three-point hitch until the Aerator is fully on the ground with all the weight off of the tractor. Put the three-point in float position and pull ahead slowly to get the spoons into the ground. Gradually increase ground speed to approximately 5mph. Do not make sharp turns with the Aerator in the ground as equipment damage may result. At the end of each pass lift the Aerator out and off of the ground until you have realigned the tractor for the next pass. Look back often to observe your pattern and to make sure you are getting good soil penetration. If you aren't achieving the desired penetration, you may need to add more weight or wait until after a rain or after irrigation has been applied to softened the ground.

Usually allow about twelve to twenty-four hours after pulling the cores before pulverizing the solid parts left on the ground with a drag mat. The pulverizing action of the drag mat breaks up the soil portion of the core which is redistributed into the undisturbed thatch layer setting off a microbial action that accelerates thatch breakdown. The vegetation portion of the core remains on the surface for debris collection or destruction by a mulching mower.

With very little practice you should become very proficient and effective with your Land Pride 25 Series Core Aerator.

At the completion of the aeration task the Aerator should be washed, cleaned and lubricated. Any lodged cores should be cleaned out of the spoons. Units being put up for the winter should also have water drained from the weight tanks and storage stands should be put in place. Store in a dry and well drained area.

Section 4: Options

Weight Tanks

**WARNING**

*Under no circumstances should riders be allowed. Never allow riders for the purpose of adding extra weight to the unit.*

**IMPORTANT:** You could lose steering control if your tractor is too light. Refer to your tractor's manual to determine if additional ballast is needed.

**Refer to Figure 4-1:**

Weight may be added installing optional Land Pride poly water tanks. Bricks, sand bags, blocks, etc. may be added if fastened securely to the frame. Do not exceed the following weight limits:

- Model CA2560 .....500 lbs.
- Model CA2572 .....600 lbs.

For additional information, see “Optional Weight Tanks” on page 8 and “Specifications and Capacities” on page 16.

See your nearest Land Pride Dealer to purchase the tanks.

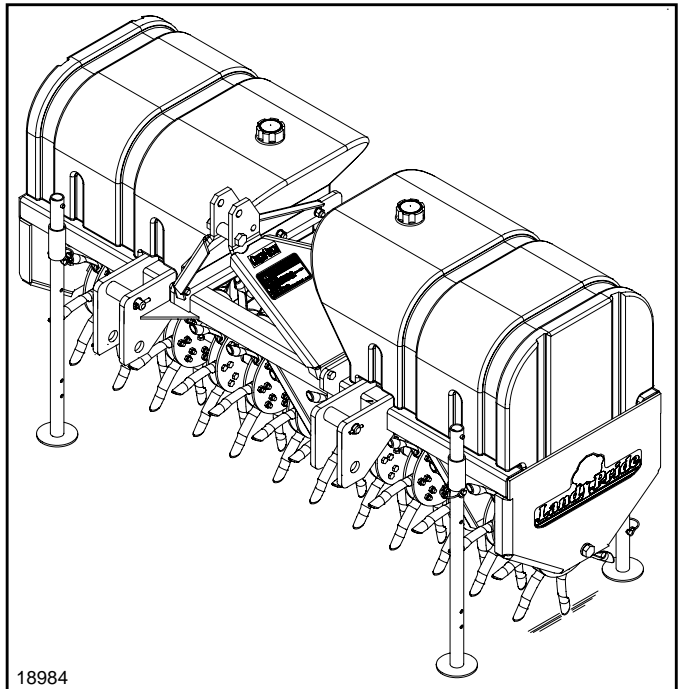

CA2560 Shown with optional water tanks  
Figure 4-1

Land Pride Weight Tanks	
Part No.	Part Description
325-026A	CA2560 WEIGHT TANK BUNDLE
325-025A	CA2572 WEIGHT TANK BUNDLE

## Section 5: Maintenance and Lubrication

### Maintenance

#### General

Proper servicing and adjustment is the key to the long life of any implement. With careful and systematic inspection, costly maintenance, time and repair can be avoided.

After using the unit for several hours, check all bolts to be sure they are tight.





Replace any worn, damaged or illegible safety labels by obtaining new labels from your Land Pride Dealer.

### Cleaning the Spoons



The spoons should be cleaned immediately after operation for easier cleaning.

The spoons can get plugged with dirt or debris. This can be removed with the use of a tool such as a screw driver or any hard pointed object. Clogged spoons reduce the efficiency of the Core Aerator.

### Lubrication

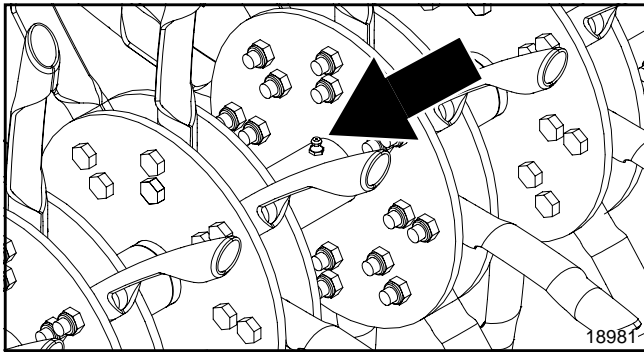
<b>Lubrication Legend</b>	 Multi-purpose spray lube	 Multi-purpose grease lube	 Multi-purpose oil lube	 <b>50 Hrs</b> Intervals in hours at which lubrication is required



	 <b>8 Hours</b>
---	--

#### Rotor

Six places

Type of Lubrication: multi-purpose grease lube

Quantity = As Required

## Section 6: Specifications & Capacities

### CA25 Series

Description	CA2560	CA2572
Working Width	60"	72"
Overall Width	68 3/4"	79 3/4"
Overall Length	30 1/4"	
Overall Height (With support stands up)	42"	
Weight (w/o added weight)	464#	480#
Number Of Spoons	96	96
Spoon Material	3/4" Closed case hardened Replaceable.	
Spoon Spacing in forward travel	7"	
Spoon Penetration	4 1/2" Depending on ground conditions and added weight.	
Gang Spacing	5 1/2"	6 1/2"
Number of Gangs	12	12
Frame Construction	Tubing 2 1/2" x 2 1/2" x 3/16"	
Hitch	Cat. 1	
Quick Hitch	Fits Land Pride's Model QH15 Quick Hitch (Upper hitch of Quick Hitch will need to be raised up to fit.)	
Support Stands	Support stands in all four corners	
Water Tank Capacity (gallons per tank)	29 gallons per tank	36 gallons per tank
Full Water Tank Weight (2-tanks)	490 lbs. Total weight	600 lbs. Total weight

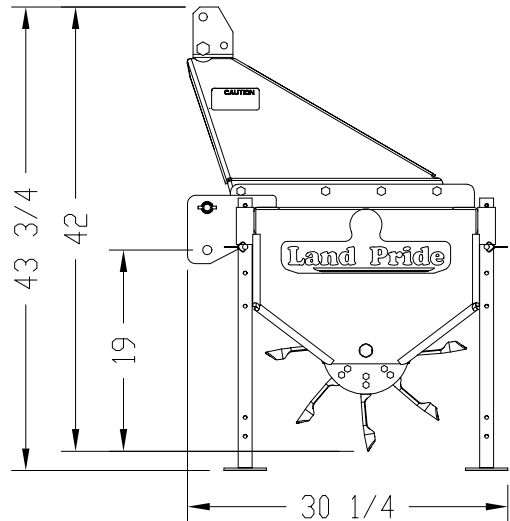
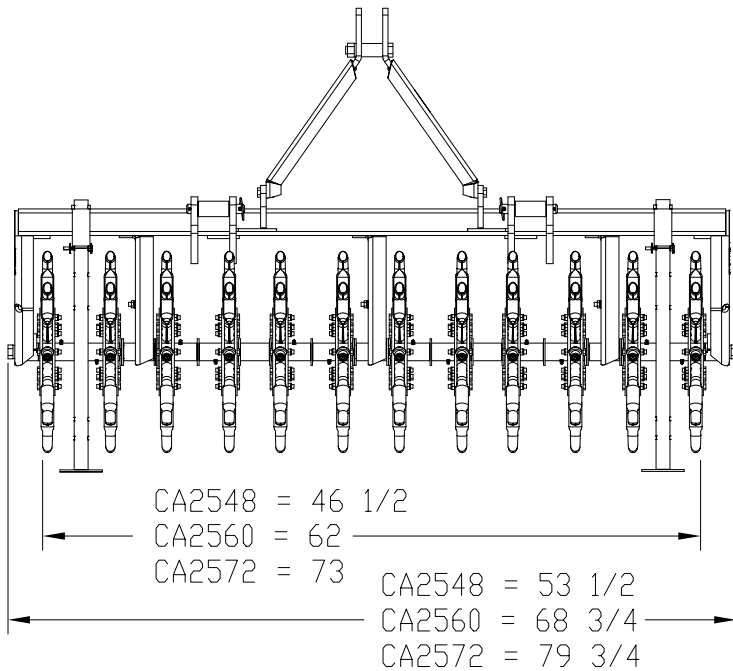

26738



## CA25 Series

Features	Benefits
<b>2 Sizes 60" &amp; 72"</b>	Great sizes for small landscapers to golf courses, campuses, cities.
<b>Cat. 1 Hitch</b>	Fits Land Pride Quick-Hitch, and stout enough to work with any Cat. 1 tractor.
<b>Plate steel 'A' frame</b>	Plate steel offers greater strength from natural force applied downward from tractor top link.
<b>Tubular Construction</b>	2 1/2" x 2 1/2" x 3/16" Tubing vs. angle iron offers greater strength as well as gives a better appearance.
<b>Expanded metal in weight tray</b>	Adds safety over spoon area, doesn't allow foreign weight object to fall into spoon area, keeps cores from being thrown forward.
<b>Hardened steel spoons</b>	3/4" ID spoons, with 3 mm wall thickness and beveled edge penetrate the ground easier than thicker OD spoons, but are just as strong.
<b>Individual Spoon Replacement</b>	Requires removal of only two bolts to replace a worn-out spoon. Don't have to disassemble the whole rotary section to get to the spoons.
<b>5 1/2" Gang spacing on 60" units 6 1/2" Gang spacing on 72" units</b>	5 1/2" on 60" Units, 6 1/2" on 72" unit offers optimum core pulling pattern.
<b>Spoon gangs</b>	Spoon gangs are independent of each other allowing for less side load torque on each gang and tearing of the turf during turns.
<b>Spoon gang greasing</b>	Each gang has a grease zerk for smooth rotation.
<b>Storage stands</b>	Each corner has a storage stand to aid in off the ground storing, as well as aiding in hooking to the tractor.
<b>Spoon spacing – forward travel</b>	7" Spacing in forward travel offers optimum aeration.
<b>Sq. foot aeration</b>	4 Cores per sq. ft. on 72" unit, and 6 cores per sq. ft. on 60".
<b>Optional Water Tanks</b>	Easily add up to 490 lbs. to the 60" and 600 lbs. to the 72" to aid in compacted soil conditions. Can easily reduce weight by draining tank incrementally. Water tanks are safer due to precise fit and fastening vs. stacking inconsistent sized objects and difficulty in uniform fastening.



## Section 8: Troubleshooting

Problem	Solution
<b>Spoons bending sideways.</b>	Raise the Core Aerator so the spoons are not engaged in the ground before attempting to turn
<b>Bending frame and or spoons</b>	Do not operate the Core Aerator on concrete, asphalt, or blacktop. Do not run over solid objects such as tree stumps, rocks, curbs, etc.
<b>Spoons won't go into ground</b>	Make sure the 3-point has not been lowered to the ground.
	Extra weight may need to be added to the frame (refer to adding weight in operating instructions). <i>Do not allow Riders for extra weight!</i>
	There may not be enough moisture in the ground
	The spoons may be clogged due to improper cleaning from the previous use. Refer to <b>"Cleaning the Spoons"</b> page 15.



Torque Values Chart For Common Bolt Size													
Bolt Size (Inches)	Bolt Head Identification						Bolt Size (Metric)	Bolt Head Identification					
	Grade 2		Grade 5		Grade 8			Class 5.8		Class 8.8		Class 10.9	
in-tpi <sup>1</sup>	N-m <sup>2</sup>	ft-lb <sup>3</sup>	N-m	ft-lb	N-m	ft-lb	mm x pitch	N-m	ft-lb	N-m	ft-lb	N-m	ft-lb
1/4" - 20	7.4	5.6	11	8	16	12	M 5 X 0.8	4	3	6	5	9	7
1/4" - 28	8.5	6	13	10	18	14	M 6 X 1	7	5	11	8	15	11
5/16" - 18	15	11	24	17	33	25	M 8 X 1.25	17	12	26	19	36	27
5/16" - 24	17	13	26	19	37	27	M 8 X 1	18	13	28	21	39	29
3/8" - 16	27	20	42	31	59	44	M10 X 1.5	33	24	52	39	72	53
3/8" - 24	31	22	47	35	67	49	M10 X 0.75	39	29	61	45	85	62
7/16" - 14	43	32	67	49	95	70	M12 X 1.75	58	42	91	67	125	93
7/16" - 20	49	36	75	55	105	78	M12 X 1.5	60	44	95	70	130	97
1/2" - 13	66	49	105	76	145	105	M12 X 1	90	66	105	77	145	105
1/2" - 20	75	55	115	85	165	120	M14 X 2	92	68	145	105	200	150
9/16" - 12	95	70	150	110	210	155	M14 X 1.5	99	73	155	115	215	160
9/16" - 18	105	79	165	120	235	170	M16 X 2	145	105	225	165	315	230
5/8" - 11	130	97	205	150	285	210	M16 X 1.5	155	115	240	180	335	245
5/8" - 18	150	110	230	170	325	240	M18 X 2.5	195	145	310	230	405	300
3/4" - 10	235	170	360	265	510	375	M18 X 1.5	220	165	350	260	485	355
3/4" - 16	260	190	405	295	570	420	M20 X 2.5	280	205	440	325	610	450
7/8" - 9	225	165	585	430	820	605	M20 X 1.5	310	230	650	480	900	665
7/8" - 14	250	185	640	475	905	670	M24 X 3	480	355	760	560	1050	780
1" - 8	340	250	875	645	1230	910	M24 X 2	525	390	830	610	1150	845
1" - 12	370	275	955	705	1350	995	M30 X 3.5	960	705	1510	1120	2100	1550
1-1/8" - 7	480	355	1080	795	1750	1290	M30 X 2	1060	785	1680	1240	2320	1710
1 1/8" - 12	540	395	1210	890	1960	1440	M36 X 3.5	1730	1270	2650	1950	3660	2700
1 1/4" - 7	680	500	1520	1120	2460	1820	M36 X 2	1880	1380	2960	2190	4100	3220
1 1/4" - 12	750	555	1680	1240	2730	2010							
1 3/8" - 6	890	655	1990	1470	3230	2380							
1 3/8" - 12	1010	745	2270	1670	3680	2710							
1 1/2" - 6	1180	870	2640	1950	4290	3160							
1 1/2" - 12	1330	980	2970	2190	4820	3560							

<sup>1</sup> in-tpi = nominal thread diameter in inches-threads per inch  
<sup>2</sup> N·m = newton-meters  
<sup>3</sup> ft-lb= foot pounds  
<sup>4</sup> mm x pitch = nominal thread diameter in millimeters x thread pitch

Torque tolerance + 0%, -15% of torquing values. Unless otherwise specified use torque values listed above.



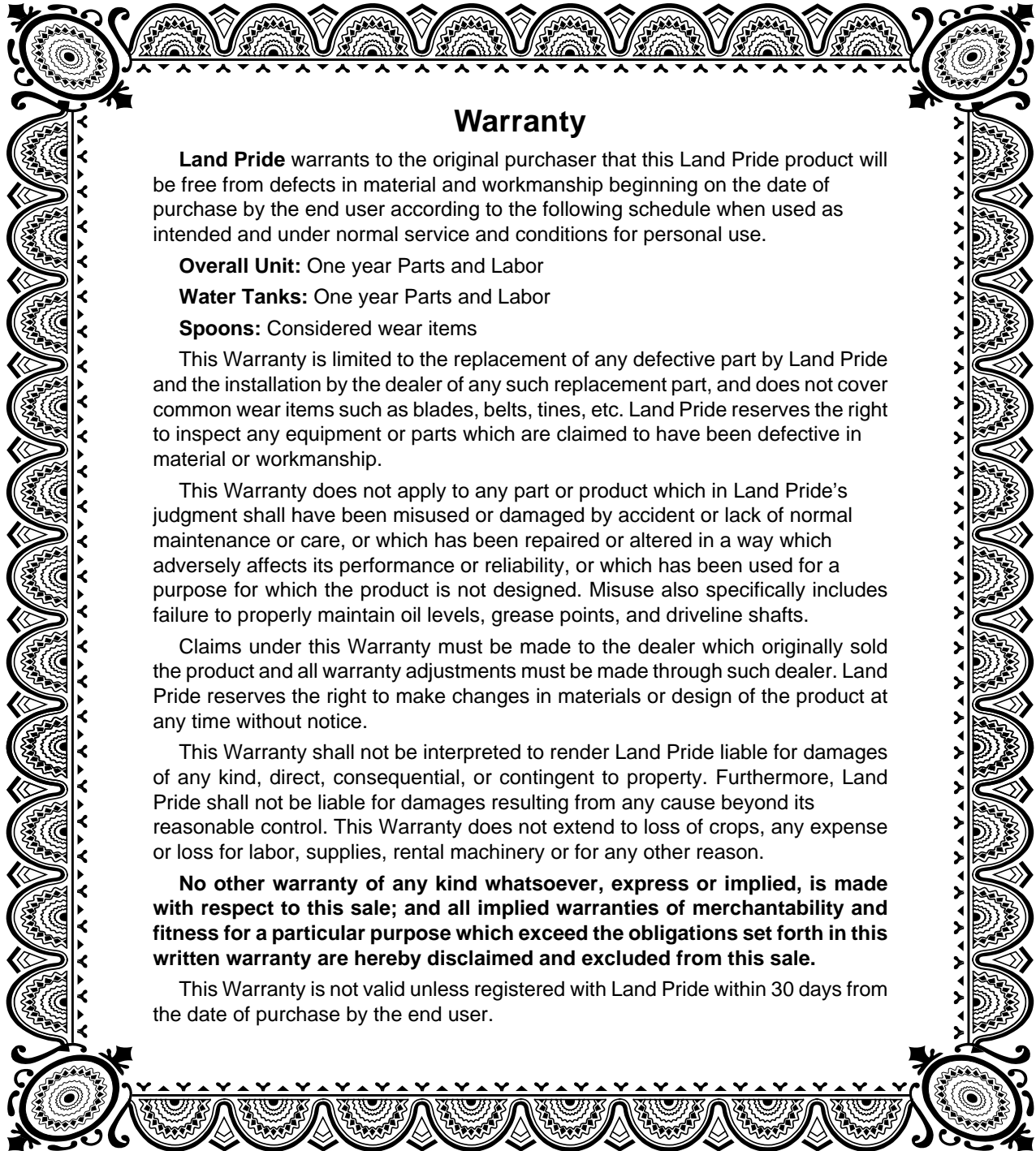

## Warranty

Land Pride warrants to the original purchaser that this Land Pride product will be free from defects in material and workmanship beginning on the date of purchase by the end user according to the following schedule when used as intended and under normal service and conditions for personal use.

**Overall Unit:** One year Parts and Labor

**Water Tanks:** One year Parts and Labor

**Spoons:** Considered wear items

This Warranty is limited to the replacement of any defective part by Land Pride and the installation by the dealer of any such replacement part, and does not cover common wear items such as blades, belts, tines, etc. Land Pride reserves the right to inspect any equipment or parts which are claimed to have been defective in material or workmanship.

This Warranty does not apply to any part or product which in Land Pride's judgment shall have been misused or damaged by accident or lack of normal maintenance or care, or which has been repaired or altered in a way which adversely affects its performance or reliability, or which has been used for a purpose for which the product is not designed. Misuse also specifically includes failure to properly maintain oil levels, grease points, and driveline shafts.

Claims under this Warranty must be made to the dealer which originally sold the product and all warranty adjustments must be made through such dealer. Land Pride reserves the right to make changes in materials or design of the product at any time without notice.

This Warranty shall not be interpreted to render Land Pride liable for damages of any kind, direct, consequential, or contingent to property. Furthermore, Land Pride shall not be liable for damages resulting from any cause beyond its reasonable control. This Warranty does not extend to loss of crops, any expense or loss for labor, supplies, rental machinery or for any other reason.

**No other warranty of any kind whatsoever, express or implied, is made with respect to this sale; and all implied warranties of merchantability and fitness for a particular purpose which exceed the obligations set forth in this written warranty are hereby disclaimed and excluded from this sale.**

This Warranty is not valid unless registered with Land Pride within 30 days from the date of purchase by the end user.

Model Number \_\_\_\_\_

Serial Number \_\_\_\_\_



Corporate Office: P.O. Box 5060  
Salina, Kansas 67402-5060 USA  
[www.landpride.com](http://www.landpride.com)

---