

No. 400-CS Junior Carpet Stretcher

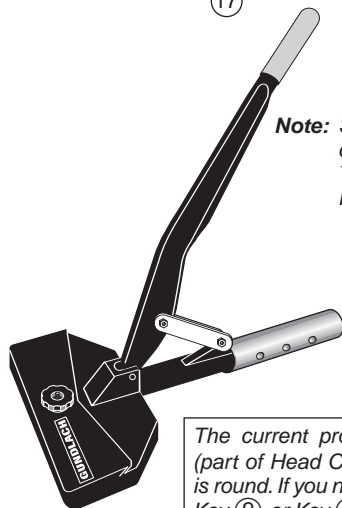

Note: See current product catalog for No. 402-TS Tubing Sections and No. 403-RC Steel Case.

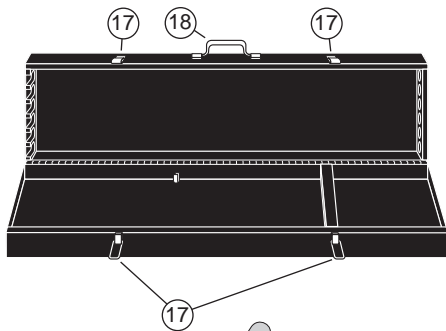
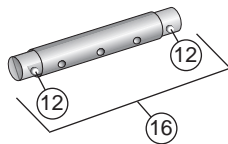

The current production Thrust Bar (part of Head Casting, see Key 8) is round. If you need to replace either Key 8 or Key 5, and your present Thrust Bar is square, you must order both Key 8 and Key 5.

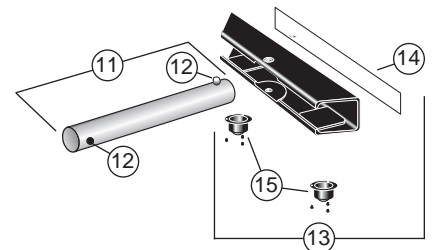
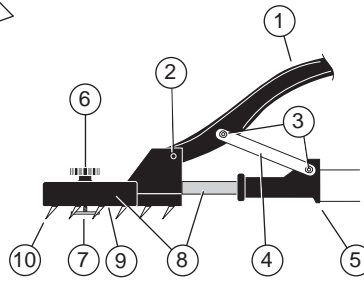

Key	Item Number	Qty. Used	Description
1	1400-B	1	Handle with Grip and Bushings
2	1400-C	1	Knurled Pin
3	1400-D	2	Link Pin with 4 Washers and 2 Nuts
4	1400-E	2	Connecting Link
5	1400-F	1	Neck Casting and Tube Assembly
6	1400-G	1	Pin Adjustment Knob with Washer
7	1400-H	1	Pin Depth Adjustment Bar with 3 Springs
8	1400-I	1	Head Casting and Thrust Bar Assembly
9	1400-J	1	Pin Plate Assembly with No. 1400-P
10	214-07	4 pkg	Kicker/Stretcher Teeth (16/package, 59/assembly)
11	1400-K	1	Tail Tube Assembly
12	402-TS-A	—	Spring Clip Assembly
13	1400-M	1	Tail Block with Pad and Casters
14	1400-Q	1	Rubber Pad for No. 1400-M
15	1400-R	1 set	Caster with 3 Screws (2/set)
16	1400-N	1	Straight Transfer Tube Assembly
17	E-1635-6AB	2 set	Large Latch Set with 4 Rivets
18	E-1635-4AB	1 set	Handle, 2 Clips and 4 Rivets
—	1400-A	1 pkg	Bushings for Nos. 1400-B and 1400-F (3/package)
—	1400-P	1 pkg	5 Screws and 3 Screw/Post Sets



Beno J. Gundlach Company
 211 North 21st Street • P.O. Box 544
 Belleville, IL 62222 • U.S.A.
 TEL: 618 233-1781 • FAX: 618 233-3636
 www.benojgundlachco.com