

MK Diamond Products, Inc.

www.mkdiamond.com

MK-1600 Electric Concrete Saw OWNER'S MANUAL & OPERATING INSTRUCTIONS

Model	Part
MK-1605B 5 Hp Single Phase Premium	168099
MK-1610B 10 Hp Single Phase Premium	168611
MK-1610B 10 Hp Three Phase Premium	167426
MK-1610B 10 Hp Three Phase Premium	167427



Revision 201	08.2018
Manual Part# 171200	

Caution: Read all safety and operating instructions before using this equipment. This owner's manual **MUST** accompany the equipment at all times.



INTRODUCTION

Congratulations on your purchase of a MK Diamond Concrete Saw. We are certain that you will be pleased with your purchase. MK Diamond takes pride in producing the finest construction power tools and diamond blades in the industry.

Operated correctly, your Concrete Saw should provide you with years of service. In order to help you, we have included this manual. This owners manual contains information necessary to operate and maintain your Concrete Saw safely and correctly. Please take the time to familiarize yourself with the Concrete Saw by reading and reviewing this manual.

Read and follow all safety, operating and maintenance instructions.

If you should have questions concerning your Concrete Saw, please feel free to call our friendly customer service department at: 800.421.5830

Regards,

MK Diamond

NOTE THIS INFORMATION FOR FUTURE USE:

MODEL NUMBER:	
SERIAL NUMBER:	
PURCHASE PLACE:	
PURCHASE DATE:	

NOTE: For your (1) one year warranty to be effective, complete the warranty card (including the Serial Number) and mail it in as soon as possible.

TABLE OF CONTENTS

SAFETY

General Safety Precautions	4-7
California Proposition 65 Message	8
Electrical Requirements and Grounding Instructions	9-12
Safety Label Locations	13
Product Specifications	14

UNPACKING, TRANSPORT and ASSEMBLY

Unpacking	15
Contents	15
Transport	16
Assembly	17-18

STARTUP, OPERATION and SHUTDOWN

Pre-Start Up	19
Operation	20-22
Cleanup	23

MAINTENANCE AND TROUBLESHOOTING

Maintenance	23-24
Troubleshooting	25

ACCESSORIES ORDERING and RETURN INSTRUCTIONS

Accessories	26
Ordering Information	28
Return Material Policy	28
Packaging Instructions	28
Authorized Service Centers	28
Contact	29
Warranty	29

Read and follow all safety, operating and maintenance instructions. Failure to read and follow these instructions could result in injury or death to you or others. Failure to read and follow these instructions could also result in damage and/or reduced equipment life. Safety warnings and guidelines do not by themselves eliminate danger. They are not substitutes for proper accident prevention procedures and good judgement.

SAFETY MESSAGES

A safety message alerts you to potential hazards that could hurt you or others. Each safety message is preceded by a safety alert symbol () and one of three words: **DANGER**, **WARNING**, or **CAUTION**.



DANGER You **WILL** be **KILLED** or **SERIOUSLY INJURED** if you **DO NOT** follow directions.



WARNING You **CAN** be **KILLED** or **SERIOUSLY INJURED** if you **DO NOT** follow directions.



CAUTION You **CAN** be **INJURED** if you **DO NOT** follow directions. It may also be used to alert against unsafe practices.

DAMAGE PREVENTION AND INFORMATION MESSAGES

A Damage Prevention Message is to inform the user of important information and/or instructions that could lead to equipment or other property damage if not followed. Information Messages convey information that pertains to the equipment being used. Each message will be preceded by the word **NOTE**, as in the example below.

NOTE: Equipment and/or property damage may result if these instructions are not followed.

GENERAL SAFETY PRECAUTIONS AND HAZARD SYMBOLS

In order to prevent injury, the following safety precautions and symbols should be followed at all times!



ALWAYS read this Owner's Manual before operating the machine. **DO NOT** operate or service this equipment before reading this entire manual. Read and understand all warnings, instructions and controls on the machine. Know how to stop the equipment quickly in case of emergency. It is the operators responsibility to use this machine under safe working conditions and conform with federal, state and local codes or regulations pertaining to safety, air, pollution, noise etc...



ALWAYS keep the Blade and Belt Guards in place. **DO NOT** operate this machine with any guard or safety device removed. A Guard, or any damaged part should be repaired or replaced immediately.



NEVER operate this equipment without proper protective clothing, shatterproof glasses, steel-toed boots and other protective devices required by the job. Non-slip foot wear is recommended.

**PERSONAL PROTECTIVE EQUIPMENT**

ALWAYS wear approved respiratory, head, ear and eye protection when operating this machine.

**ACCIDENTAL STARTS!**

Before starting the engine/motor, be sure the **ON/OFF** switch is in the **OFF** position to prevent accidental starting. Place the **ON/OFF** switch in the **OFF** position before performing any service operation. **ALWAYS** place the power **ON/OFF** switch in the **OFF** position when the machine is not in use.

**ROTATING PARTS**

Keep hands, feet, hair, and clothing away from all moving parts to prevent injury. Never operate the motor with covers, shrouds, or guards, removed.

**HOT PARTS!**

Engine components can become extremely hot from operation. To prevent severe burns, do not touch these areas while the engine is running, or immediately after it is turned off. Never operate the engine with heat shields removed.

**OVER SPEED**

NEVER tamper with the governor components or settings to increase the maximum speed. Severe personal injury and damage to the engine or equipment can result if operated at speeds above maximum.

**ELECTRICAL SHOCK**

NEVER touch electrical wires or components while the engine is running. Exposed, frayed or worn electrical wiring and plugs can be sources of electrical shock which could cause severe injury or burns. Do not touch the plug with wet hands.



ALWAYS avoid inhalation of and skin contact with silica dust and/or mist. Provide proper dust removal. Use dust-collection system when applicable.



NEVER operate the machine in an explosive atmosphere or near combustible materials. Sparks from the cutting-action of this machine can ignite flammable materials, liquids, gases or dust.



This equipment should not be operated by persons under 18 years of age.

**KEEP CHILDREN AWAY**

All visitors and children should be kept a safe distance from work area. Maintain a safe operating distance to other personnel.

**MAKE THE WORKSHOP KID PROOF**

Make the workshops kid proof by using padlocks, master switches or by removing starter keys.

**DO NOT FORCE THE TOOL**

A power tool will do a job better and safer operating at the rate for which it was designed. **DO NOT** force a tool or an attachment to do a job that it was not designed to do.

**USE PROPER APPAREL**

DO NOT wear loose clothing, gloves, neckties, rings, bracelets, or other jewelry that may be caught in moving parts. Non-slip footwear is recommended. Wear protective hair covering to contain long hair.

**SECURE WORK**

Clamps or a vise should be used to hold work whenever practical. Keeping your hands free to operate a power tool is safer.

**DO NOT OVERREACH**

Keep proper footing and balance at all times by not overreaching.

**DISCONNECT TOOLS**

Power tools should always be disconnected before servicing, adjusting or when changing accessories, such as blades, bits, cutters, and the like.

**MAINTAIN TOOLS WITH CARE**

Keep tools clean and maintained for the best and safest performance. Always follow maintenance instructions and examine the machine before use. If any abnormal vibrations or noises occurs, turn off machine immediately and have the problem corrected before further use.

**REMOVE ADJUSTING KEYS AND WRENCHES**

Form a habit of checking to see that keys and adjusting wrenches are removed from the power tool before it is turned on.

**KEEP WORK AREA CLEAN**

Cluttered work areas and benches invite accidents. Keep area around machine clear of obstructions which could cause persons to fall.

**DO NOT USE IN DANGEROUS PLACES**

DO NOT operate equipment in dangerous or hazardous environments. **DO NOT** use power tools in damp or wet locations nor expose them to rain. Always keep the work area well lighted.

**USE RECOMMENDED ACCESSORIES**

Consult the owner's manual for recommended accessories. Using improper accessories may increase the risk of personal or by-stander injury. Unauthorized equipment modifications will void all warranties. Manufacturer does not assume responsibility for any accident due to equipment modifications.



ALWAYS ensure that the machine is on level ground before using.

**NEVER STAND ON THE TOOL**

Serious injury could occur if a power tool is tipped, or if a cutting tool is unintentionally contacted.

**TRANSPORT**

When loading or unloading the machine, use caution. Remove the blade prior to hoisting, loading and transporting the machine.

**CHECK FOR DAMAGED PARTS**

Before using a power tool, check for damaged parts. A guard or any other part that is damaged should be carefully checked to determine if it would operate properly and perform its intended function. Always check moving parts for proper alignment or binding. Check for broken parts and mountings and all other conditions that may affect the operation of the power tool. A guard, or any damaged part, should be properly repaired or replaced. Always check the machine for loose bolts before starting.

**DIRECTION OF ROTATION**

A blade or cutter should always be installed so that rotation is in the direction of the arrow imprinted on the side of the blade or cutter. It should correspond with the rotational direction of the motor.

**NEVER LEAVE A TOOL UNATTENDED**

TURN POWER OFF - Do not leave a tool until it comes to a complete stop. **ALWAYS** turn a power tool **OFF** when leaving the work area, or, when a cut is finished.



NEVER disconnect any "emergency or safety devices". These devices are intended for operator safety. Disconnection of these devices can cause severe injury, bodily harm, or even death! Disconnection of any of these devices will void all warranties. Unauthorized equipment modifications will void all warranties. Manufacturer does not assume responsibility for any accident due to equipment modifications.



NEVER use this machine with any cutter designed for woodworking.



NEVER operate this equipment when not feeling well due to fatigue, illness or taking medicine.



NEVER operate this equipment under the influence of drugs or alcohol.



On belt driven equipment, overtensioning of belts will result in premature crank and/or bearing failure.



Whenever necessary, replace nameplate, operation and safety decals when they become difficult to read.



ALWAYS store equipment properly when it is not being used. Equipment should be stored in a clean, dry location out of the reach of children



DO NOT lend or rent this equipment without including the Owner's Manual and the Engine/Motor Manufacturer's Manual.



Check the chemical properties of the material to be cut/grinded and follow all EPA/OSHA Regulations. (cut/ground)

SILICA DUST WARNING

Grinding/cutting/drilling of masonry, concrete, metal and other materials with silica in their composition may give off dust or mists containing crystalline silica. Silica is a basic component of sand, quartz, brick clay, granite and numerous other minerals and rocks. Repeated and/or substantial inhalation of airborne crystalline silica can cause serious or fatal respiratory diseases, including silicosis. In addition, California and some other authorities have listed respirable crystalline silica as a substance known to cause cancer. When cutting such materials, always follow respiratory precautions.

Use appropriate NIOSH-approved respiratory protection where dust hazard may occur. Paper masks or surgical masks without a NIOSH approval number are not recommended because they do little to protect the worker. For more information about respirator programs, including what respirators have received NIOSH approval as safe and effective, please visit the NIOSH website at:

<http://www.cdc.gov/niosh/topics/respirators>

Observe OSHA regulations for respirator use (29 C.F.R. §1910.134).

Visit <http://www.osha.gov> for more information.

CALIFORNIA PROPOSITION 65 MESSAGE

Some dust created by power sanding, sawing, grinding, drilling, and other construction activities contain chemicals known (to the State of California) to cause cancer, birth defects or other reproductive harm. Some examples of these chemicals are:

- Lead, from lead-based paints
- Crystalline silica, from bricks and cement and other masonry products
- Arsenic and chromium, from chemically treated lumber

For further information, consult the following sources:

<http://www.osha.gov/dsg/topics/silicacrystalline/index.html>

<http://www.cdc.gov/niosh/docs/96-112/>

<http://oehha.ca.gov/prop65/law/P65law72003.html>

<http://www.dir.ca.gov/Title8/sub4.html>

<http://www.P65warnings.ca.gov>

Your risk from these exposures varies depending on how often you do this type of work. To reduce your exposure to these chemicals, work in a well-ventilated area, and work with approved safety equipment, such as dust masks that are specially designed to filter out microscopic particles. Where use of a dust extraction device is possible, it should be used. To achieve a high level of dust collection, use an industrial HEPA vacuum cleaner. Observe OSHA 29 CFR part 1926.57 and 1926.103.

ELECTRICAL REQUIREMENTS AND GROUNDING INSTRUCTIONS

In order to prevent electrical shock and injury, the following electrical safety precautions and symbols should be followed at all times!



WARNING

In case of a malfunction or breakdown, grounding provides a path of least resistance for electrical current to reduce the risk of electric shock. This tool is equipped with an electric cord which has an equipment-grounding conductor and a grounding plug. The plug must be plugged into a matching outlet that is properly installed and grounded in accordance with all local codes and ordinances.

- **DO NOT** modify the plug provided - if it will not fit the outlet, have the proper outlet installed by a qualified electrician.
- Improper connections of the equipment-grounding conductor can result in a risk of electric shock. The equipment-grounding conductor is the insulated conductor that has an outer surface that is green, with or without yellow stripes. If repair or replacement of the electric cord or plug is necessary, **DO NOT** connect the equipment-grounding conductor to a live terminal.
- Check with a qualified electrician or service personnel if the grounding instructions are not completely understood, or if in doubt as to whether the tool is properly grounded.
- Use only 3-wire extension cords that have 3-prong grounding plugs and 3-pole receptacles that accept the tool's plug.
- Repair or replace a damaged or worn cord immediately.

ELECTRIC MOTOR SAFETY

For maintenance care and operation of the electric motor, refer to your electric motor instruction booklet furnished with the electric motor. Protect the electric motor from dust as much as possible and keep ventilating openings clean. Before plugging in the machine, make sure that the outlet voltage is within the voltage marked on the machines's data plate.



CAUTION



DO NOT spray water on the electric motor. **DO NOT** touch the plug with wet hands. To reduce the risk of electrocution, keep all connections dry and off the ground.



DO NOT operate electric motor in an explosive environment.



DO NOT EXPOSE TO RAIN

DO NOT expose to rain or use in damp locations.

**WARNING**

If operating the equipment in damp locations is unavoidable, **ALWAYS** use a Ground Fault Circuit Interrupter, **ALWAYS** wear rubber gloves and footwear in damp conditions.



DO NOT abuse the cord. Never use the cord to carry the equipment or to pull the plug from the outlet. Keep the cord away from heat, sharp edges, and moving parts. Replace damaged cords immediately. Damaged cords increase the risk of electric shock.

**WARNING**

To reduce the risk of electrocution, keep all connections dry and off the ground. A Ground Fault Circuit Interrupter (GFCI) should be provided on the circuit(s) or outlet(s) to be used for this machine. Receptacles are available having built-in GFCI protections and may be used for this measure of safety. When using an extension cord, GFCI should be installed closest to the power source, followed by the extension cord and lastly, the machine.

If the plug or receptacle gets wet, **DO NOT** unplug the cord. Disconnect the fuse or circuit breaker that supplies power to the tool. Then unplug and examine for presence of water in the receptacle.

**WARNING**

Use only extension cords that are intended for outdoor use. These extension cords are identified by a marking "Acceptable for use with outdoor appliances; store indoors while not in use." Use only extension cords having an electrical rating not less than the rating of the product. **DO NOT** use damaged extension cords. Examine extension cords before using and replace if damaged. **DO NOT** abuse extension cords and **DO NOT** yank on any cord to disconnect. Keep cords away from heat and sharp edges. Always disconnect the extension cord from the receptacle before disconnecting the product from the extension cord.

ALWAYS make certain that the power source required for the electric motor is correct and always use the correct NEMA configuration plug. Motors can burn out when the line voltage falls 10% below the voltage rating of the motor. Failure to use proper voltage will cause the motor to overheat. Make certain that the correct size grounded (3-wires) extension cord is used.

**WARNING**

Use of undersized extension cords result in low voltage to the motor that can result in motor burnout and premature failure. MK Diamond warns that equipment returned to us showing signs of being run in a low voltage condition, through the use of undersized extension cords, will be repaired or replaced totally at the customer's expense. There will be no warranty claim.

To choose the proper extension cord,

- Locate the length of extension cord needed in the table below.
- Once the proper length is found, move down the column to obtain the correct AWG size required for that length of extension cord.

MOTOR SPECS			EXTENSION CORD LENGTH			
Motor	Voltage	Amps	25'	50'	100'	200'
172414	240V 1 Ph	19.5	12 ga	12 ga	8 ga	6 ga
165675	230V 1 Ph	38	8 ga	8 ga	6 ga	4 ga
165676	230V 3 Ph	28.4	10 ga	10 ga	8 ga	6 ga
165676	460V 3 Ph	14.2	14 ga	14 ga	12 ga	12 ga

OPERATION & SAFETY DECALS

The MK-1600 Concrete Saw is equipped with a number of safety decals. These decals are provided for operator safety and maintenance information. Should any of these operation or safety decals become unreadable, replacements can be obtained by calling (800) 421-5830.

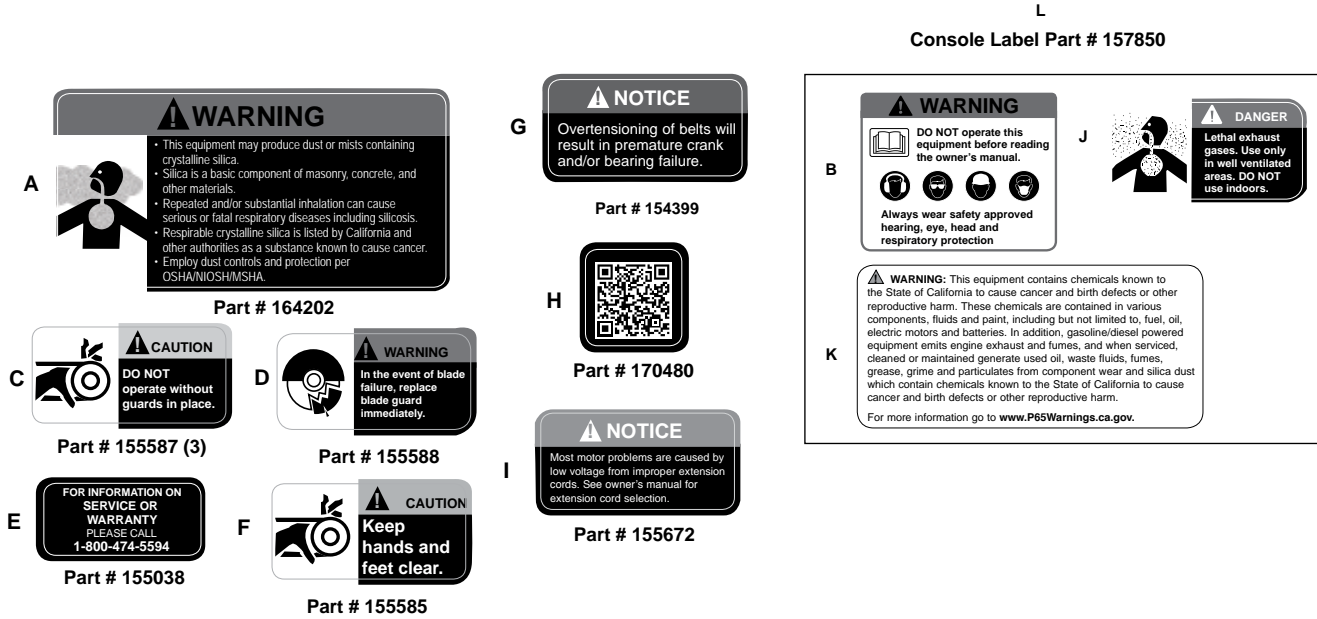

Location	Description
A Motor	Warning - Silica
B Console	Read Manual
C Shaft/Blade Guard/Belt Guard	Guards in Place
D Blade Guard	Replace Blade Guard
E Motor	Service
F Frame/Front	Hand & Feet Clear
G Belt Guard	Overtensioning Belts
H Console	QR Manuals
I Console	Extension Cords
J Console	Lethal Exhaust
K Console	Prop 65
L Console	Machinery Hazard

SAFETY DECALS LOCATION

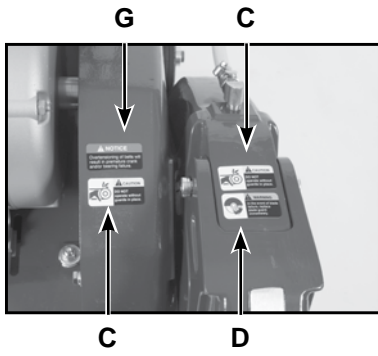
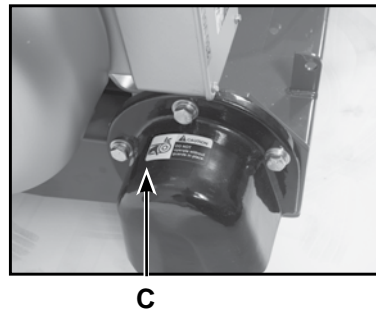
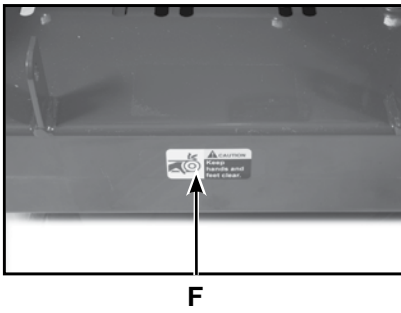
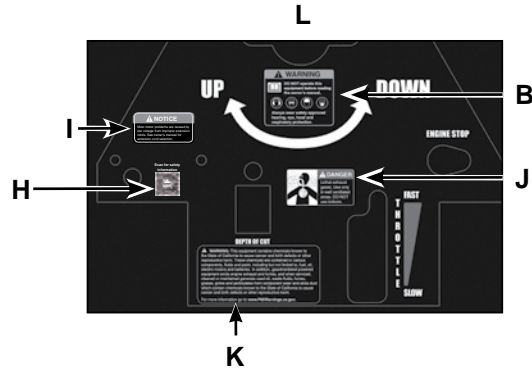
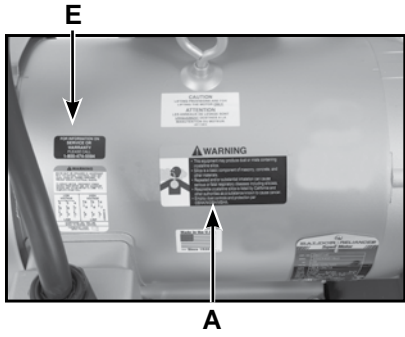

PRODUCT SPECIFICATIONS

The MK-1600 is a versatile electric powered Concrete Saw. Operated and used according to this manual, the MK-1600 will provide years of dependable service.

General Description

The MK-1600 is engineered as a portable concrete saw powered by a Baldor motor. The saw is capable of 6-5/8" depth of cut with an 18" blade.

Saw Specifications

Model	MK-1605B Premium	MK-1610B Premium	MK-1610B Premium	MK-1610B Premium
Motor	Baldor (Electric)	Baldor (Electric)	Baldor (Electric)	Baldor (Electric)
Power	5 Hp	10 Hp	10 Hp	10 Hp
Arbor Size	1" (25 mm)	1" (25 mm)	1" (25 mm)	1" (25 mm)
Blade Capacity	18" (457 mm)	18" (457 mm)	18" (457 mm)	18" (457 mm)
Blade RPM	2,400	2,400	2,400	2,400
Depth of Cut	6-5/8" (168 mm)	6-5/8" (168 mm)	6-5/8" (168 mm)	6-5/8" (168 mm)
L x W x H (inches)	42" x 25" x 39"	43" x 25.5" x 39"	43" x 25.5" x 39"	43" x 25.5" x 39"
L x W x H (mm)	1067 x 635 x 991	1092 x 648 x 991	1092 x 648 x 991	1092 x 648 x 991
Voltage	240V	230V	230V	460V
Amperage	19.5	38	28.4	14.2
Phase	1	1	3	3
Weight	275 lbs. (125 kgs)	315 lbs. (143 kgs)	315 lbs. (143 kgs)	315 lbs. (143 kgs)
Part #	168099	168611	167426	167427

Blade

The MK-1600 uses a 18 inch diameter diamond blade.

Concrete Saw Usage

The MK-1600 is designed to cut various grades of concrete surfaces.

MK-1600 Series Features

- One-piece box construction chassis made from 3/16" hot-rolled steel
- Powder-coated chassis resists peeling and corrosion
- Cast-aluminum hinged blade guard
- Stainless steel water distribution system supplies water to both sides of blade
- 1" blade shaft supported by two heavy-duty, self-aligning pillow block bearings
- Depth control assembly is engineered for smooth, controlled blade insertion
- Durable 8" x 2-1/4" non-slip rubber wheels with maintenance-free hubs & roller bearings
- Positive-locking depth control mechanism
- One-year limited warranty

UNPACKING

Your saw has been shipped from the factory thoroughly inspected. Only minimal assembly and service is required. Check each item, making certain all items are accounted for and in good visual condition before discarding any packing materials. If there are any missing or damaged parts call MK Diamond Customer Service at 800-421-5830.







WARNING Never start motor until all initial servicing and set up steps are completed according to this operations manual and motor manual. Read and familiarize yourself with all controls and features of the saw before beginning operations.

Remove the saw from the pallet and place it on a flat surface. Two people are required to lift saw.

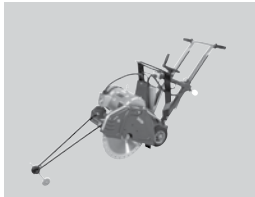
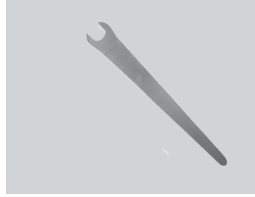
CONTENTS

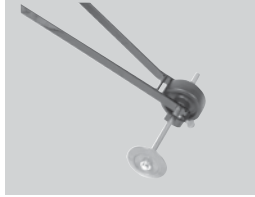
In the containers you will find one (1) MK-1600 Saw, one (1) Blade Shaft Wrench, one (1) Handlebar, two (2) Handlebar Bolts and Washers, one (1) Pointer, one (1) MK-1600 Owner's Manual, one (1) Warranty Card.

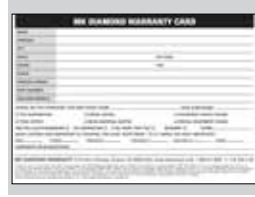
			
<p>MK-1600 Saw</p>	<p>1 Blade Shaft Wrench</p>	<p>Handlebar</p>	<p>Handlebar Bolts and Washers</p>
			
<p>Pointer</p>	<p>MK-1600 Owner's Manual</p>	<p>Warranty Card</p>	

TRANSPORT



- CAUTION**
1. The MK-1600 weighs approximately three hundred and fifteen (315 pounds), use care when transporting.
 2. Two people are required to lift and transport the MK-1600.

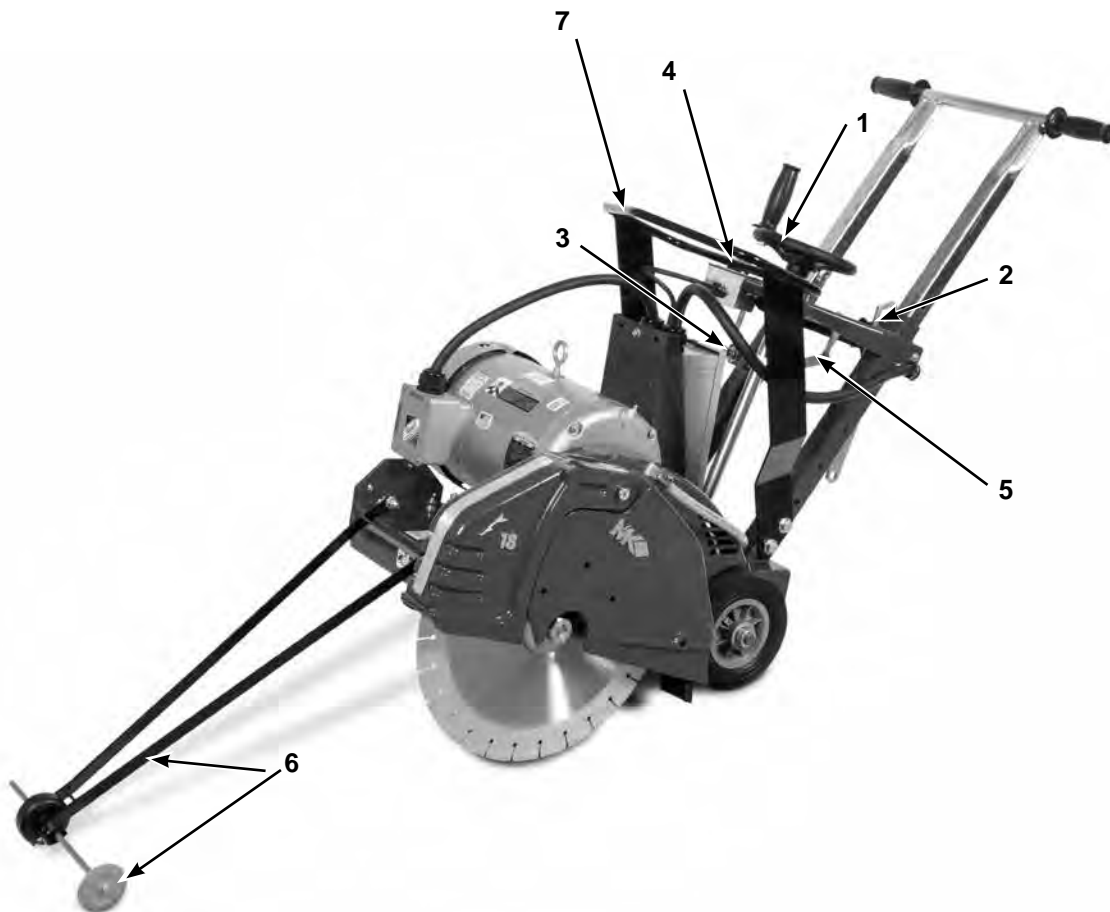

1. The raise lever wheel raises the blade when rotated clockwise and lowers the blade when rotated counterclockwise.
2. The raise/lower wheel lock is engaged when the knob is tightened.
3. The water control lever is off in the vertical position and fully on in the horizontal position. It may be placed at in between settings to regulate the water flow.
4. The OFF switch is located on the console for quick motor shut-off.
5. Depth control clamp must be adjusted for desired depth of cut.
6. The pointer is set in line at the factory but should be checked for proper alignment with the blade after every use.
7. Lifting bail to assist with transportation.

Follow the assembly instructions to prepare your saw for operation.

Handlebar Assembly



(A)

Locate the threaded holes on both sides of the handlebar.



(B)

Align the handlebar with the holes on both sides of the frame at the desired height.



(C)

Install one Washer onto each bolt. Install bolt through the Handlebar and into the holes and tighten.

Diamond Blade Installation

- NOTE:**
1. When installing the blade retaining-bolt, ensure the threads of the bolt are aligned with the threads of the drive shaft so as not to “cross-thread” the bolt.
 2. When installing the blade ensure that the blade shaft and flanges are free from dirt and all foreign material before mounting blade on the blade shaft. Tightening a blade against an uneven surface can cause fracture or cause the blade to run out of alignment.
 3. Blade shaft threads are left-handed on the right side of the saw and right-hand on the left of the saw.



(A)

Open the Blade Guard Cover. Locate the Blade Shaft Nut and the Outer Flange.



(B)

Loosen the Blade Shaft Nut while holding the Shaft Wrench steady.

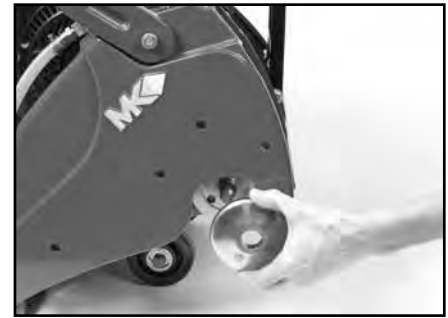

(C)

Remove the Blade Nut and Outer Flange.

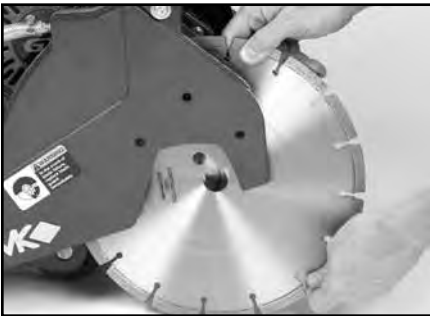

(D)

Install the Diamond Blade onto the Blade Shaft. Ensure directional arrow on the blade indicates proper rotational direction.



(E)

Install the Outer Flange. Verify the drive pin is seated; it must project through the hole in the blade and into the flange.



(F)

Install the Blade Shaft Nut.



(G)

Tighten Blade Shaft Nut holding the Blade Shaft steady. Lower and close Blade Guard.

CAUTION

Diamond Blades improperly used are dangerous. Comply with American National Standards Institute Safety Code, B7.1 and, Occupational Safety and Health Act covering Speed, Safety Guards, Flanges, Mounting Procedures, General Operating Rules, Handling, Storage and General Machine Conditions.

Pre-Start Inspection

The pre-start inspection should be performed before beginning any job. If Diamond Blade is worn, replace the blade before starting work.

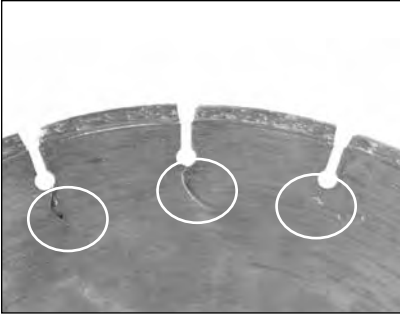

(A)

Inspect Blade for damage for cracks. Verify the Blade is correct for the material being cut.



(B)

Inspect the saw for general damage and/or loose hardware.

Motor Start



(A)

Use the Depth Control Wheel to raise the Blade clear of the floor.



(B)

Push out red button.



(C)

Push green button to start motor.

Front Pointer Alignment

The Front Pointer is set in line at the factory. However, the pointer should be checked for proper alignment with the blade after every use.

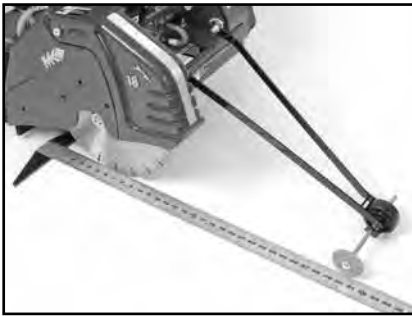

(A)

Using a straight edge, carefully mark a line 12 feet long on a smooth level concrete surface. Place Saw parallel to line; lower Blade and center it over the line.



(B)

With the Blade centered over the line and the Saw Frame parallel to the line, lower the front Pointer assembly and position the pointer over the line.

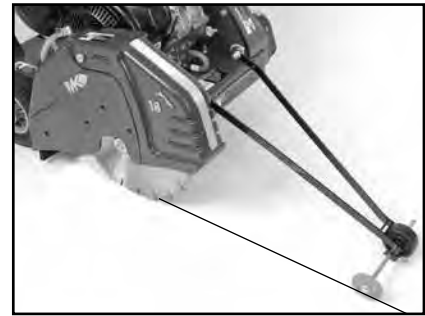

(C)

Adjust the Pointer in or out if the orange wheel is off the line by loosening the thumbscrew on the end of pointer. Align orange wheel with line and tighten thumbscrew.

Adjusting Depth of Cut Gauge



(A)

Loosen Depth Lock Knob.



(B)

Turn Crank Wheel until Blade touches the ground.



(C)

Loosen Depth Indicator Knob and slide the Depth Control Clamp until the Depth of Cut Indicator reads zero.



(D)

Tighten Depth Indicator Knob.



(E)

Tighten Depth Lock Knob.

Standard Operation

The MK-1600 is intended for industrial applications and operated by experienced professionals. The operator must be aware of the machine's capabilities and limitations. It is the operators responsibility to use this machine under safe working conditions and conform with federal, state and local codes or regulations pertaining to safety, air, pollution, noise etc...



CAUTION

Prior to operation of this machine the operator must determine the existence and location of any subsurface features that may be hazardous or could damage the equipment, (i.e. electric cable, natural gas line etc...)



(A)

Use the Depth Control Wheel to raise the blade clear of the floor.



(B)

Attach the water hose to the water supply valve.

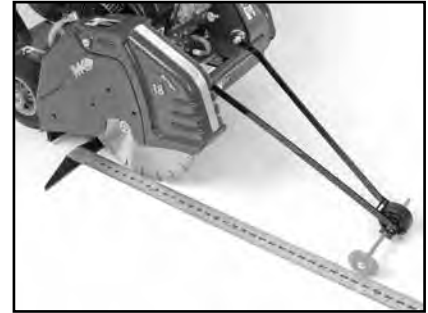

(C)

Lower the Pointer. Using a Straight-edge, align the Pointer to the Blade see "Front Pointer Alignment."

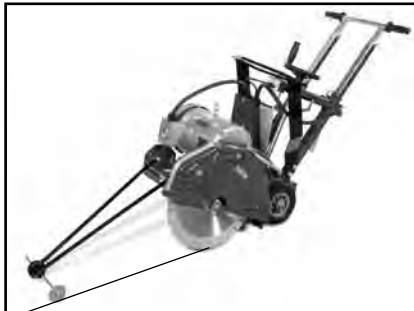

(D)

Layout and mark the area to be cut using a chalk-line. Align Pointer and Blade to chalk-line.



(E)

To start saw pull red button.



(F)

Then push the green button.



(G)

For Wet Cutting, open water supply valve. Verify proper cooling flow and adjust the water flow on the Blade to a desired amount.

NOTE: Perform the cut using only enough pressure to follow the original marked line. The saw has a natural tendency to pull towards the side on which the blade is mounted. To assure straight line cutting, apply pressure to the appropriate handle. If excessive pressure is required reduce the forward speed of the saw. Driving the saw too fast while cutting may cause the front wheels to lift causing the blade to cut at uneven depths. Do not attempt to steer the saw. Sudden and severe corrections can cause the blade to be damaged or broken.



(J)

Slowly lower the Blade until the desired depth is reached and begin the cut.



(K)

When the cut is complete, raise the Blade completely out of the cut by turning Depth Control Wheel counter-clockwise.



(L)

Close water supply valve.



(M)

Shut down saw by pushing red button.

Dry Cutting

NOTE: 1. Ensure the blade you are using is clearly marked for dry cutting.



WARNING

Dry cutting has the potential to expose you to high levels of crystalline silica. Repeated and/or substantial inhalation can cause serious or fatal respiratory diseases including silicosis. For more information go to www.P65Warnings.ca.gov. Employ dust controls and protection per OSHA/NIOSH/MSHA.

Airflow helps to cool the blade during dry cutting. Cutting too deep with one pass, or exerting excessive forward or side pressure can be dangerous and cause damage. Step cut in increments of 2 inches or less, for best results. Thinner blades are especially advantageous when cutting dry.

Cleanup

- NOTE:**
1. To extend operating life, the Concrete Saw should be cleaned following every use.
 2. Use care when cleaning around electrical components.



(A)

Clean the saw with soap and water.



(B)

Clean around the Console.



(C)

Clean the Depth Control Screw and lubricate as needed.



(D)

Clean water system outlets, including water tubes in blade guard.



(E)

Clean the remainder of the exterior surface.

MAINTENANCE SAFETY

- Always push the motor red button to turn the saw off.
- **NEVER** lubricate components or attempt service on a running machine.
- Keep the machinery in proper running condition.
- Fix damage to the machine immediately and always replace broken parts, or missing decals.

New Maintenance

Perform the following after initial purchase and operation of the saw.

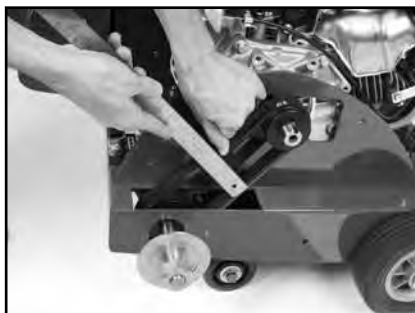

(A)

Check and adjust tension on all belts following first 48 hours of operation (See Belt section).

Weekly (50 hours) and Monthly (200 hours)

The following should be performed monthly. Items should be lubricated using waterproof grease.



(A)
Lubricate the Depth Control
Screw (Monthly).

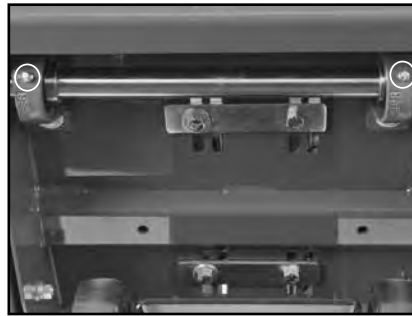

(B)
Lubricate the Blade Shaft Bear-
ings (Monthly).

Diamond Blade Removal

(A)
Open the Blade Guard Cover.

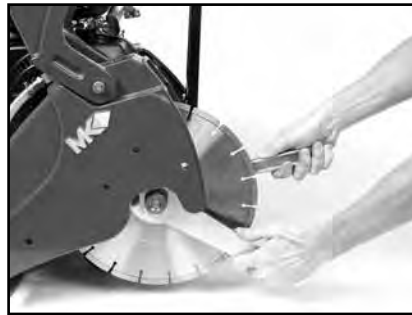

(B)
Remove the Blade Shaft Nut and
the Outer Flange.

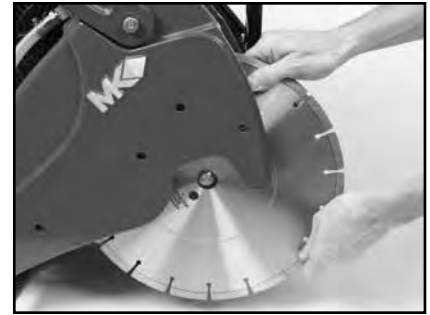

(C)
Remove blade.

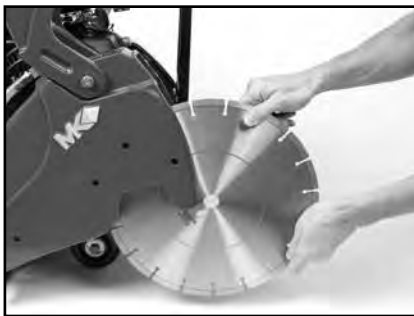

(D)
Install the new Blade, Retaining
Bolt and Outer Flange.

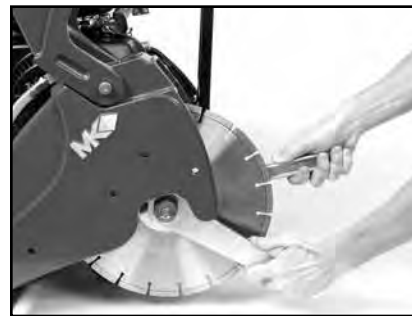

(E)
Tighten Blade Retaining Bolt
while holding the Blade Shaft
steady.

TROUBLESHOOTING







When trouble occurs, be sure to check the simple causes which, at first, may seem too obvious to be considered. Refer to the table below for problems and their possible causes.

Problem \ Cause	Improper Blade for the Application	Improper Belt Tension	Damage Caused by External Objects
Reduced blade life	X	X	
Excessive belt wear		X	X

SAW STOPS

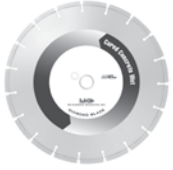
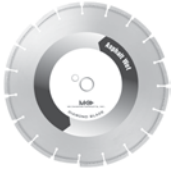
Push reset button, check connections and check circuit breaker.

ACCESSORIES

ITEM	NUMBER	DESCRIPTION	
1	134965	MK-500 18" x .125 x 1" Standard grade wet cutting blade for cured concrete	
2	129072	MK-505 18" x .125 x 1" Premium grade, wet cutting blade for cured concrete	
3	134965	MK-525 18" x .125 x 1" Supreme grade, wet cutting blade for cured concrete	
4	133850	MK-705W 18" x .142 x 1" Premium grade, wet cutting blade for asphalt	
5	139162	MK-610W 18" x .142 x 1" Supreme grade, wet cutting blade for green concrete	
6	153550	MK-465D 18" x .142 x 1" Premium grade, dry cutting blade for asphalt and green concrete	
7	157852	6.5 Gallon Water Tank	
8	157745	Lifting Bail	

ORDERING INFORMATION

You may order MK Diamond products through your local MK Diamond distributor or, you may order direct from MK Diamond.

When ordering direct from MK Diamond, please have the following information ready before calling:

- The Model Number of the saw
- The Serial Number of the saw
- Where the saw was purchased and when
- The Part Number for the part(s) being ordered
- The Part Description for the part(s) being ordered

NOTE: Standard orders are \$50.00 or more when ordering direct from MK Diamond. A \$6.00 charge will be added to orders having a net billing value under \$50.00. A nominal handling fee of \$5.00 may apply to some orders.

All parts may be ordered by calling toll free to – 800 421-5830 or 310 539-5221 and asking for Customer Service. For technical questions, call – 800 474-5594.

RETURN MATERIALS POLICY

To expedite the service relative to the return of a product purchased through MK Diamond, please observe the following:

NOTE: When returning all items, they must have been purchased within the previous twelve (12) months.

- Have the Model Number of the saw
- Have the Serial Number of the saw
- Have the location of where the saw was purchased
- Have the date when the saw was purchased
- Contact Customer Service for approval to return the item(s)
- Obtain a Returned Goods Number (RGA) authorizing the return
- Follow the packaging instructions in the following section
- Ensure the RGA number is on the outside of the returned package
- Ensure your item(s) are prepaid to the destination

For returned items, call toll free to – 800 421-5830 or 310 539-5221 and ask for Customer Service.

PACKAGING INSTRUCTIONS

- Remove the Cutting Head and Support Angle Assembly
- Dry the saw before shipping
- When packing, include the following: Saw, Diamond Blade, Blade Guard and Support Angle Assembly and Adjustable Cutting Guide (Other Accessories are not required)
- Package the unit in its original container or one of comparable size (do not ship the unit partially exposed)
- Ensure all parts are secured in the packaging to prevent moving

AUTHORIZED SERVICE CENTERS

For quicker repair time, you may contact MK Diamond Customer Service, toll free, at 800 421-5830 or 310 539-5221 for the Authorized Service Center closest to you or visit our web site at www.mkdiamond.com. For technical questions, call – 800 474-5594.

CONTACT

Please contact MK Diamond Products, Inc. Customer Service Department with any questions you might have regarding distributors, parts or service.

Telephone: **(800) 421-5830**

Fax: **(310) 539-5158**

E-mail: **Customer_Service@MKDiamond.com**

Customer Service Hours: **Monday through Friday, 6AM-4PM PST**

MK Diamond Products, Inc.

1315 Storm Parkway

Torrance, CA 90501

MK DIAMOND PRODUCTS, INC. LIMITED WARRANTY

MK DIAMOND PRODUCTS, INC. will guarantee every machine they build, to be free from defects in material and workmanship for (1) one year from date of purchase. The obligation of MK DIAMOND PRODUCTS, INC. under this warranty is limited to the repair or replacement of any parts which, under normal use, prove to be defective in material or workmanship. The parts involved or the unit in question should be returned to MK DIAMOND PRODUCTS, INC. or to a point designated by us, transportation prepaid.

This warranty does not obligate us to bear the cost of labor or transportation charges in connection with replacement or repair of defective parts. Likewise, it shall NOT apply to any unit which has been subjected to misuse, neglect or accident. This warranty does NOT apply to any machine which has been repaired or altered outside our factory.

This warranty does NOT obligate MK DIAMOND PRODUCTS, INC., with respect to items not of our manufacture, such as engines, motors, hydraulics, etc., which are subject to their own guarantees and warranties.

We shall in no event be liable for consequential damages or contingent liabilities arising out of failure of any equipment or parts to operate properly.

© COPYRIGHT 2018, MK DIAMOND PRODUCTS, INC. ALL RIGHTS RESERVED.

The MK Diamond logo is a registered trademark of MK Diamond Products, Inc. and may not be used, reproduced, or altered without written permission. All other trademarks are the property of their respective owners and used with permission.

MK Diamond may have patents, patent applications, trade marks, copyrights of other intellectual property right covering this product in this document.

This manual MUST accompany the equipment at all times. This manual is considered a permanent part of the equipment and should remain with the unit if resold.

The information and specifications included in this publication were in effect at the time of approval for printing.

MK-1600 Electric
OWNER'S MANUAL & OPERATING INSTRUCTIONS



MK Diamond Products, Inc.

MK Diamond Products, Inc.
1315 Storm Parkway
Torrance, CA 90501

Toll-Free: (800) 421-5830
Phone: (310) 539-5221
Fax: (310) 539-5158
www.mkdiamond.com