

DET-2 Theodolite User Guide



CONTENTS

- Cautions 3
- Usage and applications of the instrument 4
- Specifications 5
- Nomenclature 6
- Functions of buttons 8
- Preparation before measurement 9
- Battery installation 9
- Recharging of battery 10
- Eyepiece and telescope focusing 11
- Parameter settings 11
- Centering and leveling with optical plummet 14
- Operation 16
- Inspection 22
- Accessories 28
- Error codes 29

SOLD & SERVICED BY
Survey Instrument Sales
 Helping You Measure the World
 24037 Acacia Redford, MI 48239 313-535-5252

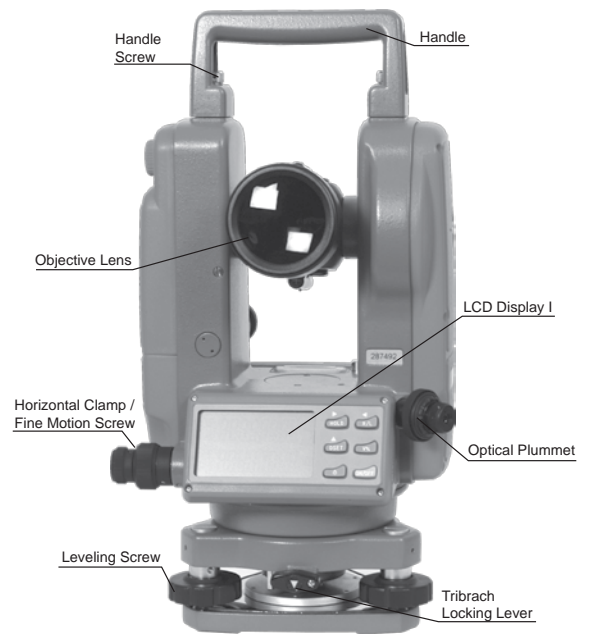

EYEPiece AND TELESCOPE FOCUSING

Adjustment of Eyepiece
 Direct the telescope to a bright background. Turn the eyepiece ring so that the crosshairs of the reticle are clearly seen.

Elimination of Optical Parallax
 Adjust the focusing ring to clearly see an object on the reticle. Move your eyes up and down to see if the image of the object moves relative to the graduation lines. If it does not move, there is no optical parallax; otherwise turn the focusing ring to eliminate the optical parallax.

Parameter Settings
 Please enter all desired initial settings prior to the first measurement.
 Items in bold indicate factory settings.

Initial Setting	Selection
1. Unit of Angle	360° / 400G / 6400 Unit A / Unit B / Unit C
2. Zenith Angle	ZEN == 0 / ZEN == 90
3. Auto Power Off Time	30 OFF / NO OFF
4. Min. Display	dsp1 / dsp5
5. Tilt Sensor Switch	TILT ON / TILT OFF
6. Indication of Horizontal Angle Position	No Beep / 90° Beep

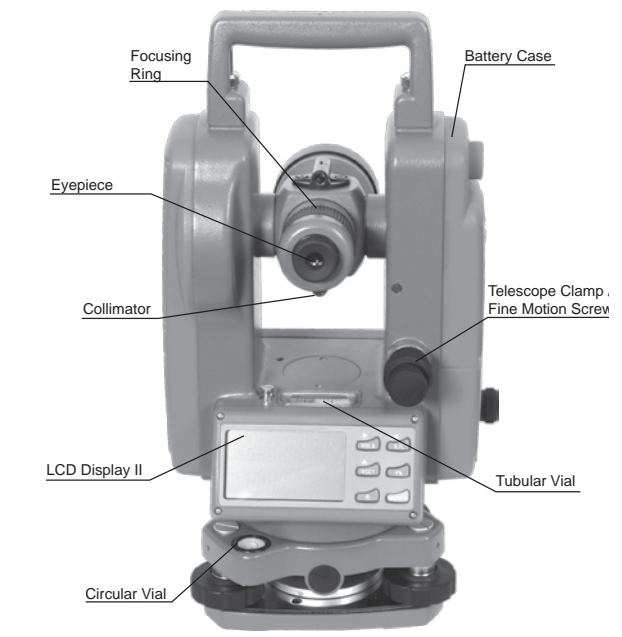

Changing Parameter Settings

Press and hold [HOLD] button + [0SET] button and press [ON/OFF] button. Release [ON/OFF] button when the full character display appears and release [HOLD] + [0SET] buttons when four beeps are heard. The instrument enters into its initial setup mode and the LCD displays:



- Press [▶] button or [◀] button to change screens for selecting options.
- Press [▲] button for selecting specific content in the options.
- Finally, press [V / %] button to confirm and enter into angle measuring mode.

- Unit of Angle**
- UNIT A: 360° (Degree)
 - UNIT B: 400 (GON)
 - UNIT C: 6400 (Mil)

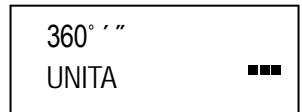

- Zero Position of Vertical Angle**
- ZEN == 0 : Zenith is 0°
 - ZEN == 90 : Zenith is 90°

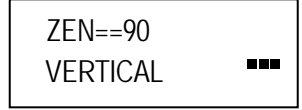

CAUTIONS
 Carefully read and understand this User Guide before use.
 Avoid eye injury. Do not aim the telescope at the sun.
 The instrument should be protected from hard shock.
 Do not carry a tripod mounted instrument on your shoulder.
 Avoid sudden changes in temperature. Sudden changes in temperature will influence the precision of measurement, will effect the operation of the electronic system, and will cause condensation on the objective lens. When the instrument is taken from the cold weather outdoor to indoor, it must be placed in a warm dry place to allow condensation to evaporate.
 This instrument contains sensitive electronic components that are protected against dust and moisture. Dust or moisture inside the instrument will cause damage. After using in a humid environment, the instrument must be dried immediately and stored in a dry instrument case.
 The LCD will respond slowly in low temperatures.

To prevent battery leakage, please remove the battery pack if the instrument will be stored for an extended length of time.

Before placing the instrument into the instrument case, align the dot marks on the instrument and lightly tighten the clamp knobs. Place the instrument in the case with dots facing upwards. Loosen clamps after the instrument is in the case and insure instrument is properly seated. Slightly tighten clamps after instrument is fully seated.

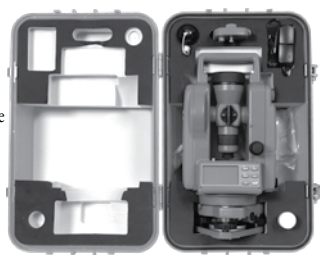

Button	Primary Function	Other
ON/OFF	Turns the instrument ON/OFF	1. Function button for entering into instrument setup. 2. Function button for entering into index error setting. 3. Function button for entering into compensation setting.
[Lighting Icon]	Button for lighting of reticule and LCD	
0SET	Reset of horizontal angle (zeroing)	1. Menu selection button in Instrument Setup. 2. Function button for entering into Compensator setting. 3. Function button for input while in Instrument Setup.
HOLD	Horizontal angle Hold Button	1. Menu selection button in Instrument Setup. 2. Function button for entering while in Instrument Setup. 3. Function button for entering into index error setting.
R/L	Increment of left rotation and right rotation of horizontal angle.	1. Menu selection button in Instrument Setup. 2. Function button for input while in Instrument Setup.
V%	Vertical angle and slope convert	1. Function button for input while in Instrument Setup. 2. Button for confirmation after initial Setup

Auto Power Off Time

- NO OFF: Auto power off disabled
- 30 OFF: Turns power off if inactive for 30 min

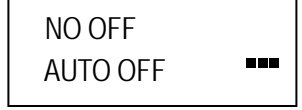

Minimum Display

- DSP 1: Minimum display is 1"
- DSP 5: Minimum display is 5"

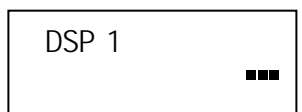

Setting of Tilt Sensor

- V TILT ON: Turn on the tilt sensor
- V TILT OFF: Turn off the tilt sensor

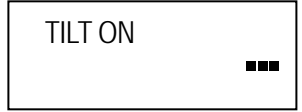

Indication of Horizontal Angle

- NO BEEP: Horizontal angle indication disabled
- 90 BEEP: Sounds beep when the instrument is close to 0°, 90°, 180° and 270°.



USAGE AND APPLICATIONS OF THE INSTRUMENT
 This electronic theodolite utilizes the photoelectric incremental angle measuring system. The precision of angle measurement is 2". It integrates optical, mechanical, electronic and computer technologies for a variety of functions including angle measurement, display and storage. It displays horizontal and vertical angles and makes conversions from vertical angle to percent. The vertical angle measurement is also compensated.
 The theodolite can be used in a variety of applications including measurement in railway, highway, bridge, water projects, etc. It can be also used in various construction applications including orientation of large equipment, topographic survey, and various kinds of construction measurements.

- 4 -

SPECIFICATIONS		
Telescope	Image	Erect
	Magnification	30x
	Aperture	45 mm (1.7 in)
	Angle of view	1° 30'
	Shortest distance	1.35 m (4.43 ft)
	Stadia constant	100
Angle Measuring System	Resolution	3"
	Angle measurement	Incremental
	Min. Reading	1" or 5"
	Detection method	H. Both sides, V. Single side
	Precision	2"
Tilt Sensor	Unit of angle	Deg / mil / gon / V %
	Display	LCD both sides
Optical Plummet	Automatic Compensation	Yes
	Range of compensation	+/-3'
	Image	Erect
	Magnification	3X
Vials	Angle of view	5°
	Focusing range	0.5 m ~ ∞ (1.6 ft ~ ∞)
	Reticle type	Crosshair
	Tubular vial	30"/2 mm
Range	Circular vial	8'/2 mm
	Temperature	-20°C to +50°C (-4°F to +122°F)
Power	Battery type	4xAA alkaline or NiMH Pack
	Voltage	4.8
	Battery Life	36 hours - alkaline
Dust / Water Protection	IP54	
Weight	4.5 kg (9.9 lbs)	
Size	164x154x340 mm (6.4x6.1x13.4)	
Warranty	1 Year	

- 5 -

PREPARATION BEFORE MEASUREMENT

Power Options
 The theodolite has two power options: Disposable and rechargeable batteries. The rechargeable batteries are supplied in a sealed pack. The disposable batteries are inside a similar shaped pack with a sliding door.

To remove the pack, turn the knob until the mark "▼" points to [UNLOCK], then remove the battery pack.

To insert battery pack, place the raised bottom part of the battery case into the slot in the theodolite.

Push the top of the battery case in place. Turn the knob until the mark "▼" points to [LOCK].

To Install Alkaline Batteries into the Disposable Battery Pack, open the battery pack cover, insert four AA alkaline batteries into the battery case according to the (+) and (-).



Centering and Leveling with Optical Plummet

- Extend the tripod legs to a suitable working height with equal length legs. Spread the tripod legs and make the tripod head as level as possible while at the same time placing the center of the tripod head directly over the ground point. Press the leg feet firmly into the ground and make sure the tripod legs are locked.
- Set the instrument carefully on the center of the tripod head orientating the leveling screws centered with each tripod leg. Attach the instrument to the tripod. Make sure the center mark is visible on all three leveling screws (this ensures a complete leveling range).



• Adjust the Optical Plummet Eyepiece to focus the crosshairs. Adjust the Optical Plummet telescope focus to see the ground clearly. If you can not see the ground point while looking through the optical plummet, carefully lift two of the tripods legs, then pivot on the third leg, carefully moving the tripod until the ground point is within one inch of the reticle. Press the two tripod feet back into the ground and recheck the optical plummet alignment. Repeat if necessary until the ground point can be seen in the optical plummet field. Complete the alignment by turning the leveling screws (you will not be level but you are pointed correctly).

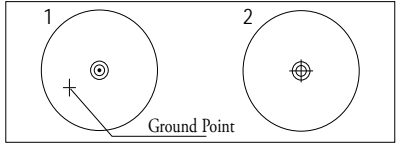

Recharging the battery
 Connect the charger to the AC power source. The green light on the charger will light. Connect the plug of the charger to the charging port of the battery pack. The green light of the charger will turn red indicating the charging process has started. After 3-4 hours the red light turns green indicating that the batteries are charged.

Caution: Do not charge Alkaline Batteries, severe damage can happen to the battery pack or charger.

Attention: Turn off the instrument's power before removing the battery pack.

Centering and Leveling with Optical Plummet

- Now center the instruments Circular Vial by carefully extending or shortening the tripod leg closest to the bubble. Caution: Use only two legs. Repeat until alignment is within 6 mm (¼ inch) or better.
- Next use the Tubular Vial to accurately level the instrument. Unlock and turn the instrument so that the tubular vial is parallel to BC, any two leveling screws. Note the direction to turn the leveling screws in the graphic. When turning the two screws, adjust them equally. The bubble will move in the direction that your left thumb turns. To move the bubble to the right, turn the B leveling screw in and simultaneously turn the C leveling screw in. To move the bubble left, move both screws out simultaneously. Once centered turn the instrument 90° over A leveling screw and turn screw A in or out until bubble is centered. Go back to the first position BC, and repeat until the bubble is centered in both positions. Then from position BC turn 180° to check the adjustment. If the bubble stays centered or within ¼ division, you are leveled.
- Now, check the ground point centering. If you are not directly on the point, carefully loosen the tripod fastener and move the instrument on the tripod head in an x - y direction. Do not rotate the instrument. Recheck leveling and repeat until instruments is level and over the ground point at the same time. With practice, this becomes easier.

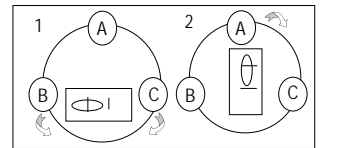

OPERATION

Start Up

- Press and hold [ON/OFF] button. Release [ON/OFF] button when the full character display appears. The LCD displays:

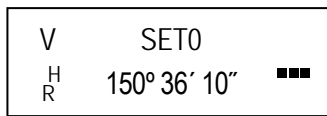

- Move the telescope up and down when the instrument is at the normal position. The beeper beeps and the LCD displays the vertical angle. The instrument enters into measuring mode.
- After the power is switched on and the instrument has entered into measuring mode, the battery level is indicated by the battery symbol in the lower right corner of LCD.
- If all of the three squares are displayed, the battery is fully charged.
- Decreasing squares indicates reduction of charge.
- If the battery symbol blinks, the battery is low and needs recharging or replacing.

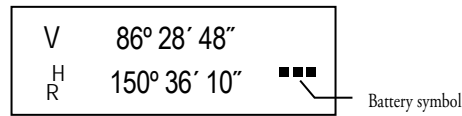

Battery symbol

- 16 -

Installation and Removal of the Base

Base Removal

- Turn the screw on the Tribrach Locking Lever outward using a flat screw driver to its stop.
- Turn Tribrach Locking Lever 180° counterclockwise. Holding the base with one hand, take the main body off the base.

Base Installation

- Turn the Tribrach Locking Knob counterclockwise until it reaches the position limit. Align the positioning block on the main body of the instrument to the notch on the base. Install the main body onto the base.
- Turn the Tribrach Locking Lever clockwise until it reaches the position limit so that the 'V' mark points downward. Turn the locking screw inward until it hits its stop.

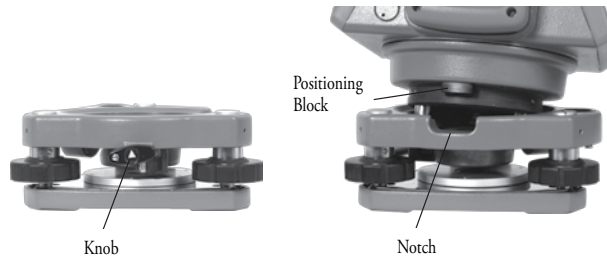

- 21 -

Collimation Error

- Attach the instrument on a tripod and precisely level.
- Aim at point A in the distance with the normal, direct position of telescope. Record the reading of the horizontal angle - HR-DIRECT. Next using the reverse position of the telescope, take the reading of the horizontal angle - HR-REVERSE, then:

$$\text{Collimation Error } C = (\text{HR-Direct} - \text{HR-Reverse} \pm 180^\circ) / 2$$

If $C < 10''$, no adjustment is required. If $C > 10''$, the following adjustment is required: Adjust the horizontal fine motion in the reverse position of the telescope so that the reverse reading $\text{HR-Rev} = \text{HR-Direct} + C$.

Remove the protective cover of the reticule of the telescope and adjust both the left and right adjusting screws so that the vertical hair of the reticule coincides with object A.

Repeat the steps until acceptable condition is reached.

Index Error of Vertical Circle

- Attach the instrument on a tripod and precisely level.
- Aim at any object, point P, in the normal position and take the reading of vertical angle - V-Direct.
- Turn the telescope to the reverse position and aim it at point P again. Take the reading of other vertical angle - V-Rev.
- If $(V\text{-Direct} + V\text{-Rev}) - 360^\circ = \leq 15''$, no adjustment is required. Otherwise, perform adjustment as follows:

Measurement of Angle

Observing in the "Normal" and "Reverse" Positions of the Telescope

The normal, or direct, position of the telescope refers to observation with the vertical circle being on the left. The reverse position refers to observation with the vertical circle being on the right. The mechanical errors can be offset by averaging the values measured in the normal and reverse positions.



Measurement of Vertical Angle

- 0° angle position can be set as follows in the initial setting:

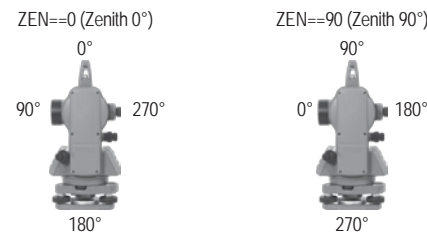

- 17 -

INSPECTION

Tubular vial

- Attach the instrument to a tripod and rough level. Position the tubular vial parallel to a line connecting any two of the three leveling screws on the base. Adjust the two leveling screws so that the tubular bubble is centered.
- Turn the instrument 180° and check if the bubble remains at the center.

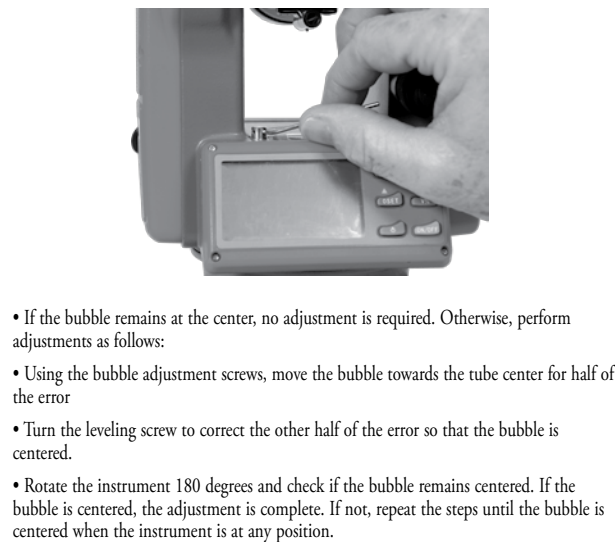

- If the bubble remains at the center, no adjustment is required. Otherwise, perform adjustments as follows:
- Using the bubble adjustment screws, move the bubble towards the tube center for half of the error
- Turn the leveling screw to correct the other half of the error so that the bubble is centered.
- Rotate the instrument 180 degrees and check if the bubble remains centered. If the bubble is centered, the adjustment is complete. If not, repeat the steps until the bubble is centered when the instrument is at any position.

- 22 -

Press and hold [R/L] + [HOLD] buttons while pressing [ON/OFF] button. Release [ON/OFF] button when full character display appears and then release [R/L] + [HOLD] buttons when four beeps are heard.

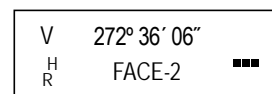
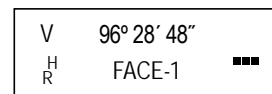

Swing the telescope near horizontal with the instrument in the normal position. Allow the vertical angle to reset after it crosses zero. Aim the telescope in the normal position at object P and press [0SET] to confirm.

Aim the telescope in the reverse position at object P and press [0SET] to confirm. With this, the compensation of index error is completed.

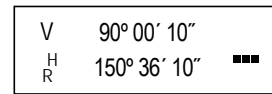

- 27 -

Compensation of the Tilt Sensor to Vertical Angle.

- If the instrument is inclined within $\pm 3'$, the tilt sensor can compensate the vertical angle. If the inclination is greater than $\pm 3'$, the instrument will display [TILT] as shown in the figure.

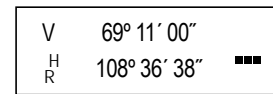
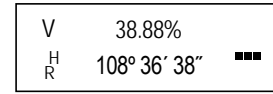
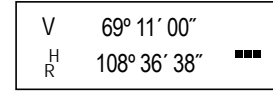
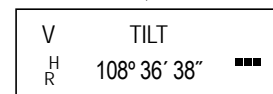
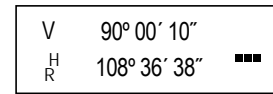

Display of slope

- Press [V/%] button, the vertical angle display is changed to slope display; press [V/%] button, the vertical angle display is resumed.

Note: When vertical angle is converted to slope, the precision of the slope reading is two digits after the decimal. The value of slope is displayed only within $\pm 45^\circ$ (100%). There will be no slope display exceeding this range.

- 18 -

Circle vial

After making sure that the tubular vial is correctly adjusted, check the circular level. If the bubble is centered, no adjustment is required. Otherwise, adjust the three adjustment screws with a needle to center the bubble.



Optical Plummet

- Attach the theodolite to a tripod (no leveling is required).
- Place a target under the instrument.
- Focus the image of the target then adjust the leveling screws so that the target is centered in the reticule.
- Turn the instrument 180°.
- If the target remains at the center of the reticule, no adjustment is required. Otherwise, adjust as follows.

- 23 -

ACCESSORIES

- 1 plumb bob
- 1 tool kit (containing a screw driver and 2 needles)
- 2 bags of desiccant
- 1 rain cover
- 1 user guide
- 1 charger
- 1 battery pack alkaline
- 1 battery pack rechargeable

- 28 -

Measurement of Horizontal Angle

- Reset of Horizontal Angle
- Press [0SET] button, the horizontal angle returns to zero

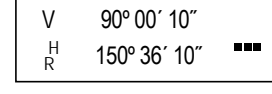
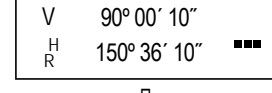
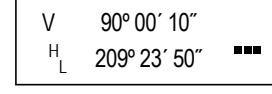
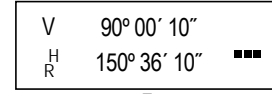
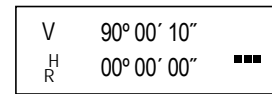
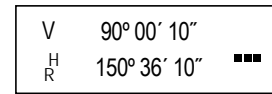

Selecting the Direction of Measurement of Horizontal Angle.

- Press [R/L] button to change the direction of measurement of the horizontal angle.

When "HR" is displayed, the angle increases with clockwise turning.

When "HL" is displayed, the angle increases with counterclockwise turning.

Holding Horizontal Angle.

- Press [HOLD] button, the horizontal angle will be held. The reading of the horizontal angle will remain unchanged even if the direction of telescope is changed. Press [HOLD] button again, the hold of horizontal angle is released.

- 19 -

Turning Off.

- Press - [ON/OFF] button and hold, "OFF" will be displayed, after a beep; release [ON/OFF] button, the instrument is turned OFF.

- Repeat the above steps until the target coincides with the center.

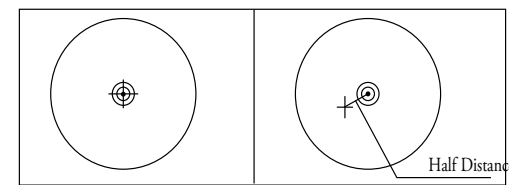

- 24 -

ERROR CODES

Display	Meaning and remedy
E01	Count error, if displayed repeatedly, repair is needed
TOO FAST	The telescope or collimation unit rotated too fast, press any key except [on/off] and [L], the instrument returns to normal state
E04	Horizontal sensor I error, repair is needed.
E05	Horizontal sensor II error, repair is needed.
E06	Vertical sensor error, repair is needed.
TILT	The tilt sensor is out of range. Level the instrument again. If this does not clear the error code, repair is needed. Note: For a temporary solution, the tilt sensor can be turned off.

Due to our policy of continuous improvement, we reserve the right to alter product design and specification without prior notification.

- 29 -

Turning Off.

- Press - [ON/OFF] button and hold, "OFF" will be displayed, after a beep; release [ON/OFF] button, the instrument is turned OFF.

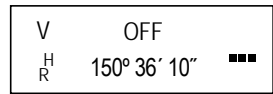

Measuring Distance Using the Stadia Method

Read the leveling rod using the stadia hair on the reticule of the telescope. Multiply the reading by 100, to obtain the actual distance L from the target to the measured point. (100 is the multiplication constant error of the instrument, i.e., $L = 1 \times 100$)

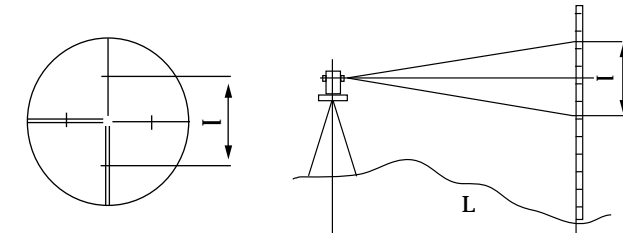

- 20 -

Perpendicularity of Vertical Crosshair of Reticule of Telescope

- Attach the instrument on a tripod and precisely level
- Place a target point, A, 50M away from instrument.
- Aim the telescope at point A. Move the telescope using the vertical fine movement. If point A moves along the vertical hair of the reticule, no adjustment is required.
- Perform the following adjustment if the point A strays from the vertical crosshair:
- Remove the protective cover of the reticule and slightly loosen the four adjusting screws. Turn the assembly so that point A coincides with the vertical hair, retighten the four adjusting screws.

Repeat the above steps until there is no error.

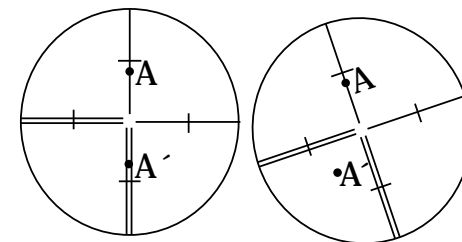

- 25 -

Notice to Our European Union Customers

For product recycling instructions and more information, please go to: www.trimble.com/environment/summary.html

Recycling in Europe

To recycle Trimble WEEE, call: +31 497 53 2430, and ask for the OWEEE associate. Or mail a request for recycling instructions to: Trimble Europe BV, c/o Menlo Worldwide Logistics, Meerheide 45, 5521 DZ Eersel, NL



Survey Instrument Sales
24037 Acacia
Redford, MI 48239
U.S.A.
Phone 1-313-535-5252



www.surveyinstrumentsales.com

- 26 -