

Figure 5. Major Components

Table 3. Generator Major Components	
ITEM NO.	DESCRIPTION
1	Muffler Assembly
2	Engine Assembly
3	Generator Assembly
4	Output Terminal Assembly
5	Fuel Tank Assembly
6	Battery Assembly
7	Generator Control Panel Assembly
8	Engine Operating Panel Assembly

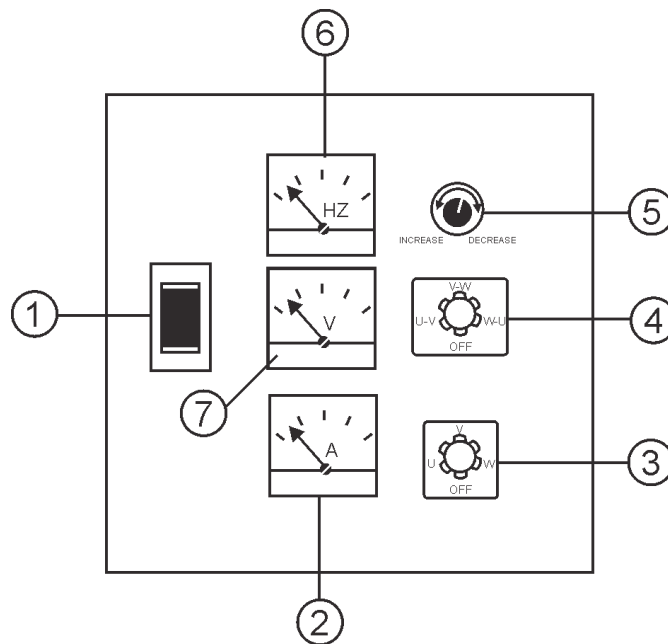

Figure 6. Generator Control Panel

The definitions below describe the controls and functions of the DCA-45SSIU2 "**Generator Control Panel**" (Figure 6).

1. **Main Circuit Breaker** – This three-pole, 110 amp main breaker is provided to protect the **UVWO** output terminals from overload.
2. **AC Ammeter** – Indicates the amount of current the load is drawing from the generator per leg selected by the ammeter phase-selector switch.
3. **Ammeter Change-Over Switch** – This switch allows the AC ammeter to indicate the current flowing to the load connected to any phase of the output terminals, or to be switched off. This switch does not effect the generator output in any fashion, it is for current reading only.
4. **Voltmeter Change-Over Switch** – This switch allows the AC voltmeter to indicate phase to phase voltage between any two phases of the output terminals or to be switched off.
5. **Voltage Regulator Control** – Allows $\pm 15\%$ manual adjustment of the generator's output voltage.
6. **Frequency Meter** – Indicates the output frequency in hertz (Hz). Normally 60 Hz ± 1 Hz .
7. **AC Voltmeter** – Indicates the output voltage present at the **UVWO** terminals.

Located behind the generator control panel is the **Generator Control Box**. This box contains some of the necessary electronic components required to make the genertator function.

The "**Control Box**" is equipped with the following major components:

- Over-Current Relay
- Voltage Rectifer
- Starter Relay
- Engine Controller (Computer Controlled)
- Current Transformer
- Voltage Selector Switch

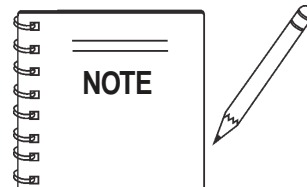

Remember the **overcurrent relay** monitors the current flowing from the **UVWO** output terminals to the load.

In the event of a short circuit or over current condition, it will automatically trip the main 250 amp breaker.

To restore power to the **UVWO** output terminals, press the **reset** button on the overcurrent relay and place the **main** circuit breaker in the **closed** position (**ON**).

DCA-45SSIU2 — ENGINE OPERATING PANEL

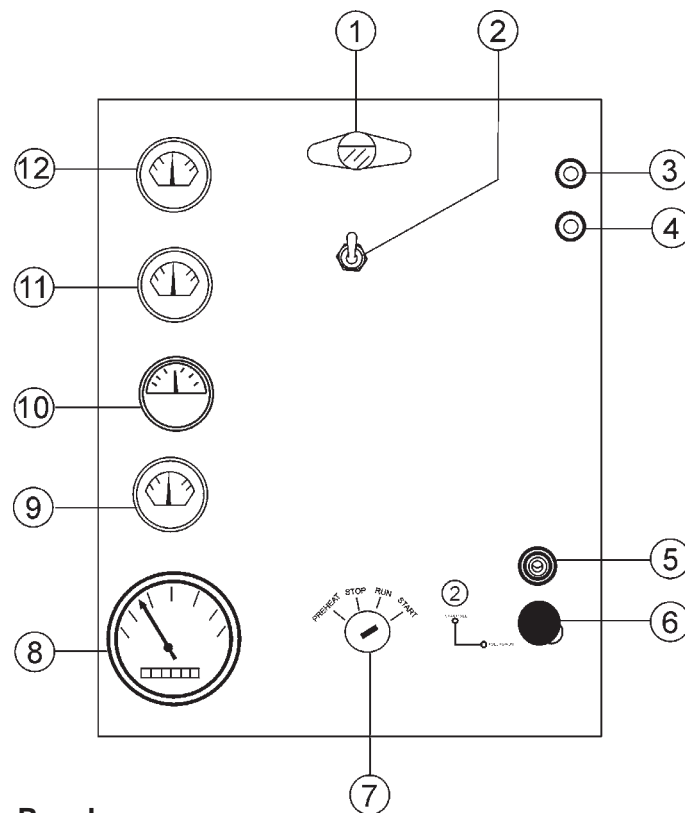

Figure 7. Engine Operating Panel

The definitions below describe the controls and functions of the DCA-45SSIU2 "**Engine Operating Panel**" (Figure 7).

1. **Panel Light** - Normally used in dark places or at night. When activated, panel will luminate. When the generator is not in use, turn the panel light switch to the 'OFF' position.
2. **Panel Light Switch**- When activated, will turn on control panel light.
3. **Water Temperature Lamp** - Indicates that the water temperature is outside of normal range and will shut down the engine.
4. **Oil Pressure Lamp** - Indicates that the oil pressure is too low or high and will shut down the engine.
5. **Pre-heat Lamp** - This indicates when the engine is ready for starting during cold weather operating conditions.
6. **Engine Speed Handle**- This handle will change the speed of the engine from **high** to **low**.
7. **Starter Switch** – Four position switch, pre-heat, stop, run and start. Insert ignition key to start and stop engine.
8. **Tachometer** – Indicates engine speed in RPM's for 60 Hz operation. This meter should indicate 1800 RPM's when the rated load is applied. In addition a built in hour meter will record the number of operational hours that the generator has been in use.
9. **Fuel Gauge** - Indicates amount of diesel fuel available.
10. **Charging Ammeter Gauge** – Indicates the current being supplied by the engine's alternator which provides current for generator's control circuits and battery charging system.
11. **Water Temperature Gauge** – During normal operation this gauge be should read between 165° F to 215° F.
12. **Oil Pressure Gauge** – Normal operation should be about 25 psi. When starting the generator the oil pressure may read a bit higher, but after the engine warms up the oil pressure should return to normal.

DCA-45SSIU2 — OUTPUT TERMINAL PANEL FAMILIARIZATION

Output Terminal Familiarization

The “**Output Terminal Panel**” (Figure 8) is provided with the following:

- Three (3) 240V output receptacles, 50 amp
- Three (3) Circuit Breakers 240V @50 amps
- Two (2) 120V GFCI receptacles, 20 amp
- Two (2) GFCI Circuit Breakers 120V@ 20 amps
- One Main Circuit Breaker 250V @110 amps
- Five (5) Output Terminal Lugs

Output Terminal Panel

The **Output Terminal Panel** (Figure 8) shown below is located on the right-hand side (left from control panel) of the generator. Lift up on the cover to gain access to receptacles and terminal lugs.

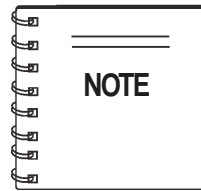

Terminal legs “O” and “Ground” are considered **bonded grounds**.

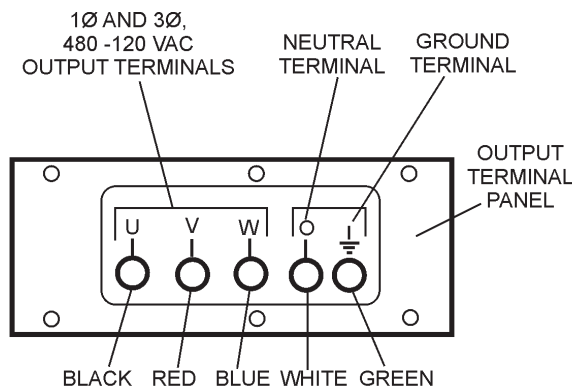
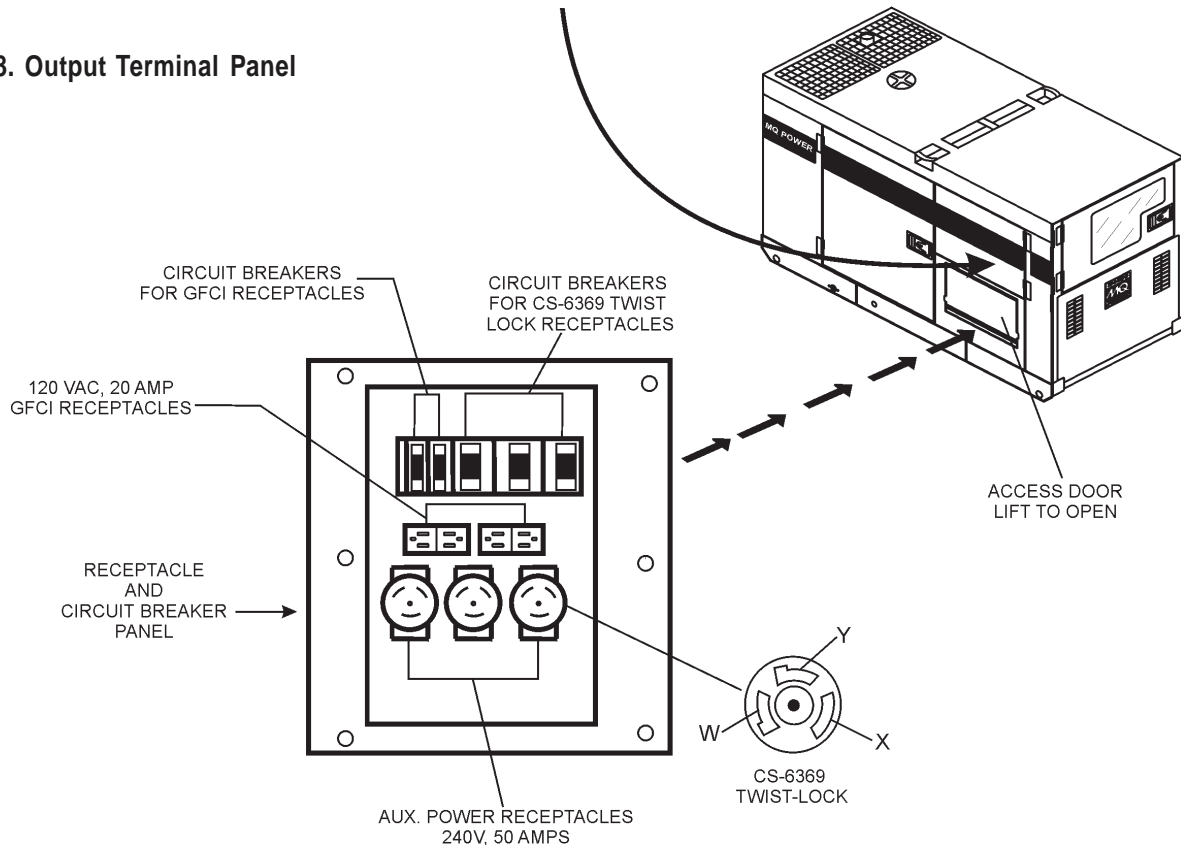

Figure 8. Output Terminal Panel



DCA-45SSIU2 — OUTPUT TERMINAL PANEL FAMILIARIZATION

120 VAC GFCI Receptacles

There are two 120 VAC, 20 amp GFCI (Duplex Nema 5-20R) receptacles provided on the output terminal panel. These receptacles can be accessed in **any voltage selector switch** position. Each receptacle is protected by a 20 amp circuit breaker. These breakers are located directly above the GFCI receptacles. Remember the load output (current) of both GFCI receptacles is dependent on the load requirements of the UVWO terminals.

Pressing the **reset** button resets the GFCI receptacle after being tripped. Pressing the "**Test Button**" (See Figure 9) in the center of the receptacle will check the GFCI function. Both receptacles should be tested at least once a month.

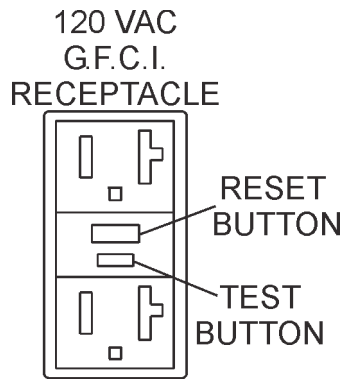

Figure 9. G.F.C.I. Receptacle

Twist Lock Dual Voltage 120/240 VAC Receptacles

There are three 240 VAC, 50 amp auxilliary twist-lock (CS-6369) receptacles (Figure 10) provided on the output terminal panel. These receptacles can **only** be accessed when the voltage selector switch is placed in the **single-phase 240/120 position**.

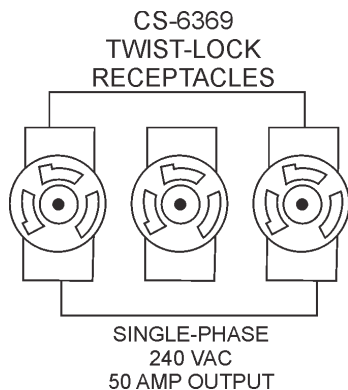

Figure 10. 240 VAC Twist-Lock Auxiliary Receptacles

Each auxilliary receptacle is protected by a 50 amp circuit breaker. These breakers are located directly above the GFCI receptacles. Remember the load output (current) on all three receptacles is dependent on the load requirements of the UVWO terminals.

Turn the **voltage regulator control knob** (Figure 11) on the control panel to obtain the desired voltage. Turning the knob clockwise will **increase** the voltage, turning the knob counter-clockwise will **decrease** the voltage.



Figure 11. Voltage Regulator Control Knob

Removing the Plastic Face Plate (UVWO Terminals)

The UVWO terminal lugs are protected by a plastic face plate cover (Figure 12). Un-lock the locking latch, and lift the terminal cover to gain access to the plastic face plate. Remove the screws securing the face plate to the terminal enclosure, then lift the plastic hinged face plate.

After the load wires have been securely attached to the UVWO terminals, reinstall the plastic face plate. Place the terminal cover in the down position and secure the locking latch.

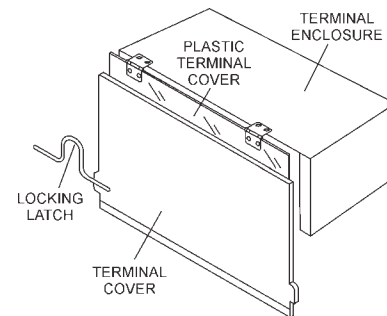

Figure 12. Plastic Face Plate (UVWO Terminals)

DCA-45SSIU2 — OUTPUT TERMINAL PANEL FAMILIARIZATION

Connecting Loads

Loads can be connected to the generator by the **UVW0** terminal lugs or the convenience receptacles. (See Figure 13). Make sure to read the operation manual before attempting to connect a load to the generator.

To protect the UVW0 output terminals from overload, a 3-pole, 250 amp, **main** circuit breaker is provided. Make sure to switch **ALL** circuit breakers to the "OFF" position prior to starting the engine.

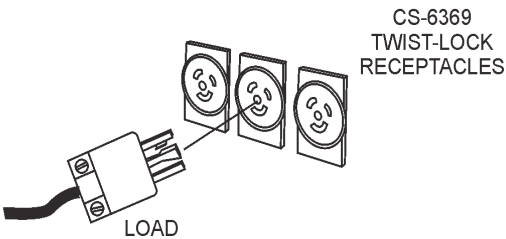
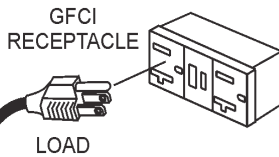
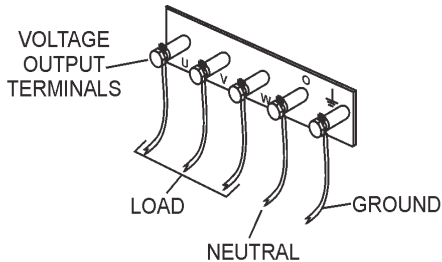

Figure 13. Connecting Loads

Over Current Relay

An **over current relay** (Figure 14) is connected to the main circuit breaker. In the event of an overload, both the circuit breaker and the over current relay may trip. If the circuit breaker can not be reset, the **reset button** on the over current relay must be pressed. The over current relay is located in the control box.

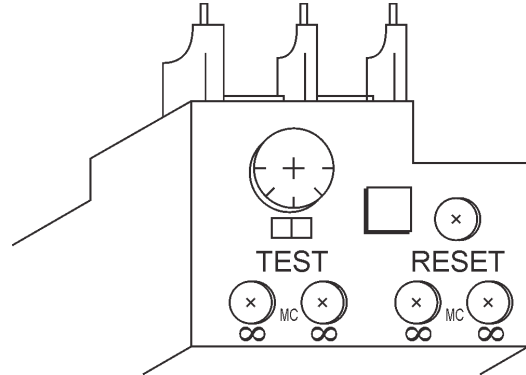

Figure 14. Over Current Relay

Single Phase Load

Always be sure to check the nameplate on the generator and equipment to insure the wattage, amperage and frequency requirements are satisfactorily supplied by the generator for operating the equipment.

Generally, the wattage listed on the nameplate of the equipment is its rated output. Equipment may require 130—150% more wattage than the rating on the nameplate, as the wattage is influenced by the efficiency, power factor and starting system of the equipment.



If wattage is not given on the equipment's name plate, approximate wattage may be determined by multiplying nameplate voltage by the nameplate amperage.

WATTS | VOLTAGE x AMPERAGE

The power factor of this generator is 0.8. See Table 4 below when connecting loads.

Type Of Load	Power Factor
Single-phase induction motors	0.4 - 0.75
Electric heaters, incandescent lamps	1.0
Fluorescent lamps, mercury lamps	0.4 - 0.9
Electronic devices, communication equipment	1.0
Common power tools	0.8

Table 5. Cable Selection (60 Hz, Single Phase Operation)

Current in Amperes	Load In Watts		Maximum Allowable Cable Length			
	At 120 Volts	At 240 Volts	#10 Wire	#12 Wire	#14 Wire	#16 Wire
2.5	300	600	1000 ft.	600 ft.	375 ft.	250 ft.
5	600	1200	500 ft.	300 ft.	200 ft.	125 ft.
7.5	900	1800	350 ft.	200 ft.	125 ft.	100 ft.
10	1200	2400	250 ft.	150 ft.	100 ft.	
15	1800	3600	150 ft.	100 ft.	65 ft.	
20	2400	4800	125 ft.	75 ft.	50 ft.	

CAUTION: Equipment damage can result from low voltage.

Three Phase Load

When calculating the power requirements for 3-phase power use the following equation:

$$KVA = \frac{VOLTAGE \times AMPERAGE \times 1.732}{1000}$$

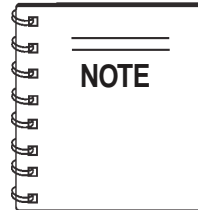

Motors and motor-driven equipment draw much greater current for starting than during operation.

An inadequate size connecting cable which cannot carry the required load can cause a voltage drop which can burn out the appliance or tool and overheat the cable. See Table 5.

- When connecting a resistance load such as an incandescent lamp or electric heater, a capacity of up to the generating set's rated output (kW) can be used.
- When connecting a fluorescent or mercury lamp, a capacity of up to the generating set's rated output (kW) multiplied by 0.6 can be used.
- When connecting an electric drill or other power tools, pay close attention to the required starting current capacity.

When connecting ordinary power tools, a capacity of up to the generating set's rated output (kW) multiplied by 0.8 can be used.

CAUTION:



Before connecting this generator to any building's electrical system, a **licensed electrician** must install an **isolation (transfer) switch**. Serious injury or death may result without this transfer switch.

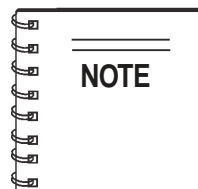

If 3Ø load (kVA) is not given on the equipment nameplate, approximate 3Ø load output may be determined by multiplying voltage by amperage by 1.732.

Generator Output Voltages

A wide range of voltages are available to supply voltage for many different applications. Voltages are selected by using the **voltage selector** switch (Figure 15). To obtain some of the voltages as listed in Table 6 (see below) will require a fine adjustment using the **voltage regulator (VR) control knob** located on the control panel.

Voltage Selector Switch

The **voltage selector** switch (Figure 15) is located above the UVWO Hard Wire Hook-up Panel. It has been provided for ease of voltage selection.

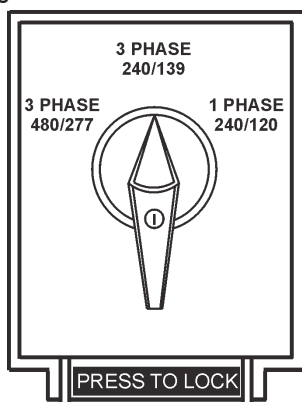

Figure 15. Voltage Selector Switch

Voltage Selector Switch Locking Button

The voltage selector switch has a locking button to protect the generator and load from being switched while the engine is running. To lock the voltage selector switch, **press** and **hold** the **red button** located at the bottom of the switch.

CAUTION:



NEVER change the position of the **voltage selector switch** while the engine is running. **ALWAYS** place circuit breaker in the open position before selecting voltage.

Generator Amperage

Tables 7 and 8 describe the generator's current output capability for both 1Ø-phase and 3Ø phase applications.

Table 7. Generator Ampere Ratings — 1Ø

kW	240V	120V
20	83	166
25	104	208
30	225	250
35	145	291
40	166	333
45	187	375
50	208	417
60 (Max)	250	500

Table 8. Generator Ampere Ratings — 3Ø

kW	208V	240V	480V
20	59	60	30
25	87	75	38
30	104	90	45
35	121	105	53
40	139	120	60
45	156	136	68
50	174	152	76
60	208	181	99

Table 6. Voltages Available

	208 VOLT	220 VOLT	240 VOLT	416 VOLT	440 VOLT	480 VOLT
Three Phase (Switchable)						
Single Phase (Switchable)	120 VOLT	127 VOLT	139 VOLT	240 VOLT	254 VOLT	277 VOLT

DCA-45SSIU2 — GENERATOR OUTPUTS/GAUGE READING

GFCI Receptacle Load Capability

The load capability of the GFCI receptacles is directly related to the voltage being supplied at either the UVWO terminals or the 3 twist lock auxilliary receptacles.

Tables 9 and 10 show what amount of current is available at the GFCI receptacles when the UVWO terminals and twist lock receptacles are in use. Be careful that your load does not to exceed the available current capability at the receptacles.

Table 9. GFCI Receptacle Load Capability

KVA in Use (UVWO Terminals)	Available Load Current (AMPS)
3Ø 240/480V	GFCI Duplex NEMA 5-20R 120V
82	0
77.8	5 amps per receptacle
73.7	10 amps per receptacle
69.5	15 amps per receptacle
65.4	20 amps per receptacle

Table 10. GFCI Receptacle Load Capability

KW in Use Twist-Lock (CS6369)	Available Load Current (AMPS)
1Ø 240/120V	GFCI Duplex NEMA 5-20R 120V
60	0
58.8	5 amps per receptacle
57.6	10 amps per receptacle
56.4	15 amps per receptacle
55.2	20 amps per receptacle

How to Read the Output Terminal Gauge.

The gauge and selector switch on the control panel **DO NOT** effect the generator output. They are provided to help observe how much power is being supplied, produced at the UVWO terminals lugs.

When the Voltage selector switch is in the 3Ø,240/139V position (See Figure 16), place the **AC Voltmeter Change-Over Switch** (Figure 17) to the W-U position and the **AC Ammeter Change-Over Switch** (Figure 19) to the U or W position to read the output on the selected leg.

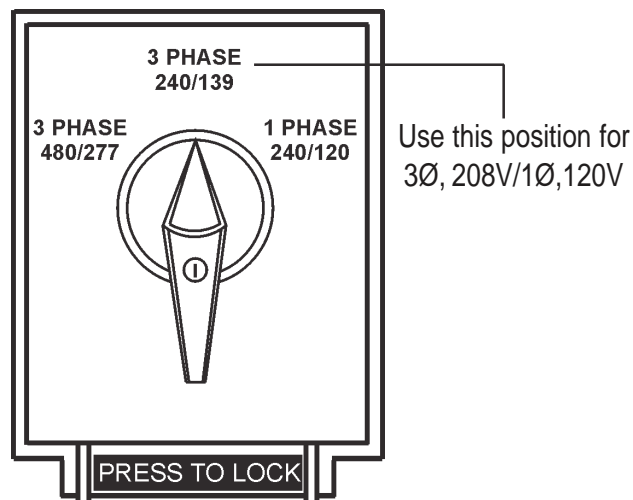

Figure 16. Voltage Selector Switch 240/139V Three Phase Position (for 3Ø, 208V, 120V voltage)

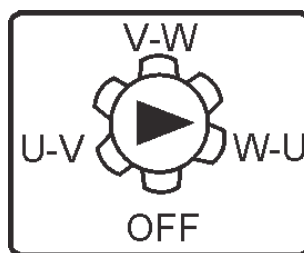

Figure 17. AC Voltmeter Change-Over Switch

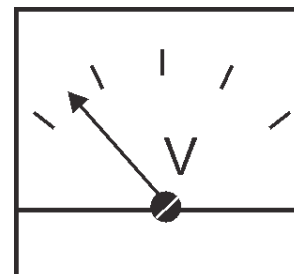

Figure 18 AC Voltmeter Gauge (Volt reading on W-U Lug)

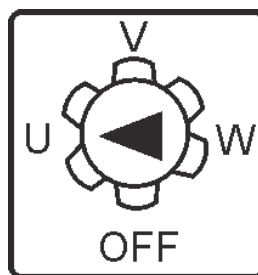

Figure 19. AC Ammeter Change-Over Switch

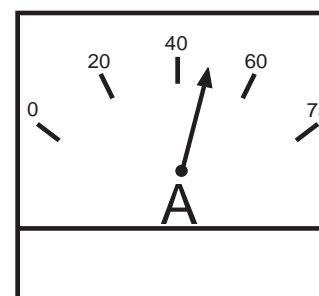
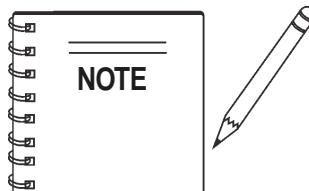

Figure 20. AC Ammeter (Amp reading on U lug)



The **ammeter** and **voltmeter** gauges are only active when the UVWO terminals are in use.

DCA-45SSIU2 — OUTPUT TERMINAL PANEL CONNECTIONS

UVWO Terminal Output Voltages

Various output voltages can be obtained using the UVWO output terminal lugs. The voltages at the terminals are dependent on the position of the **Voltage Selector Switch** and the adjustment of the **Voltage Regulator Control Knob**.

Remember the voltage selector switch determines the **range** of the output voltage. The voltage regulator (VR) allows the user to increase or decrease the selected voltage.

3Ø 240/139 UVWO Terminal Output Voltages

1. Place the voltage selector switch in the 3Ø 240/139 position as shown in Figure 21.

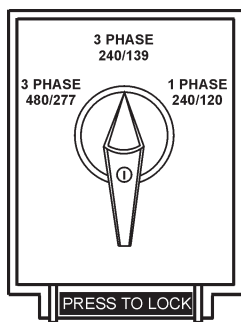

Figure 21. Voltage Selector Switch 240/139V Three-Phase Position

2. Connect the load wires to the UVWO terminals as shown in Figure 22.

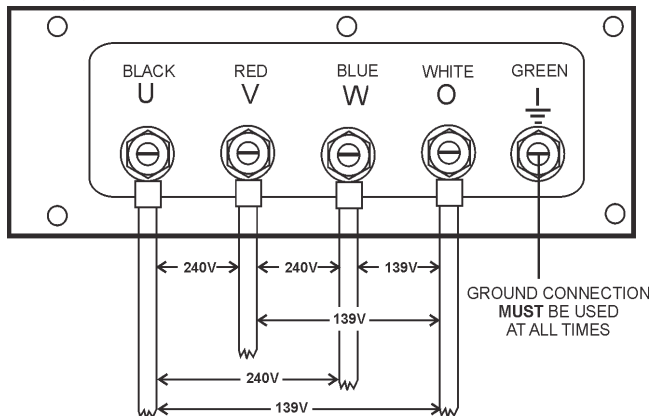

Figure 22. UVWO Terminal Lugs 240/139V Three Phase Connections

3. Turn the voltage regulator knob (Figure 23) clockwise to increase voltage output, turn counterclockwise to decrease voltage output.



Figure 23. Voltage Regulator Knob (139V/240V)

3Ø 208V/1Ø120V UVWO Terminal Output Voltages

1. Place the voltage selector switch in the 3Ø 240/139 position as shown in Figure 24.

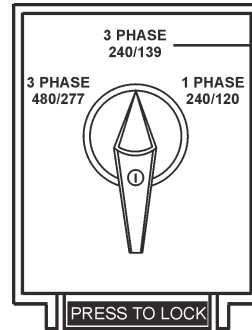

Use this position for 3Ø-208 or 1Ø120V.

Figure 24. Voltage Selector Switch 3Ø-208V/1Ø-120V Three-Phase Position

2. Connect the load wires to the UVWO terminals as shown in Figure 25.

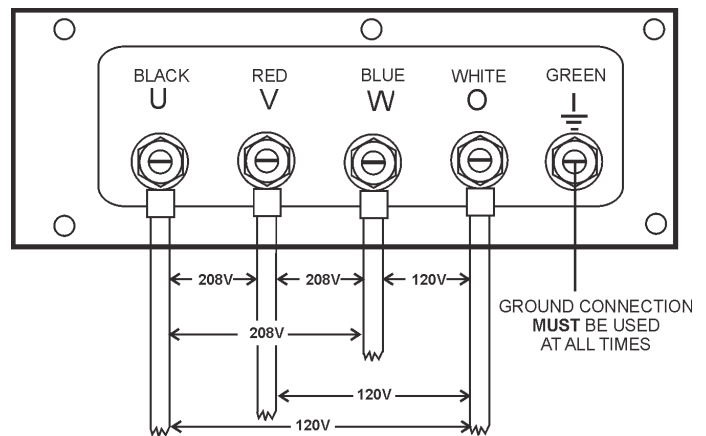
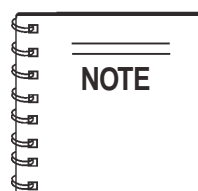

Figure 25. UVWO Terminal Lugs 3Ø-208V/120V Connections

3. Turn the voltage regulator knob (Figure 26) clockwise to increase voltage output, turn counterclockwise to decrease voltage output.



Figure 26. Voltage Regulator Knob (208V)



To achieve a 3Ø 208V output the voltage selector switch must be in the 3Ø-240/139 position and the voltage regulator must be adjusted to 208V.

DCA-45SSIU2 — OUTPUT TERMINAL PANEL CONNECTIONS

3Ø 480/277 UVWO Terminal Output Voltages

1. Place the voltage selector switch in the 3Ø 480/277 position as shown in Figure 27.

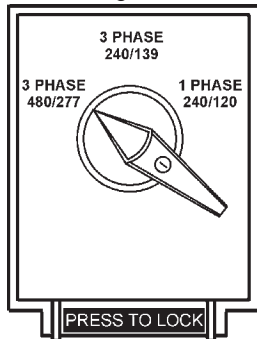

Figure 27. Voltage Selector Switch 480/277V Three-Phase Position

2. Connect the load wires to the UVWO terminals as shown in Figure 28.

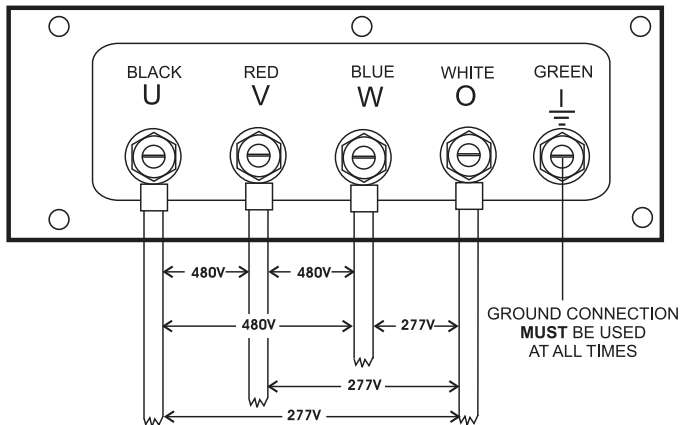

Figure 28. UVWO Terminal Lugs 240/139V Three Phase Connections

3. Turn the voltage regulator knob (Figure 29) clockwise to increase voltage output, turn counterclockwise to decrease voltage output.



Figure 29. Voltage Regulator Knob (139V/240V)

1Ø 240V/120V UVWO Terminal Output Voltages

1. Place the voltage selector switch in the 1Ø 240/120 position as shown in Figure 30.

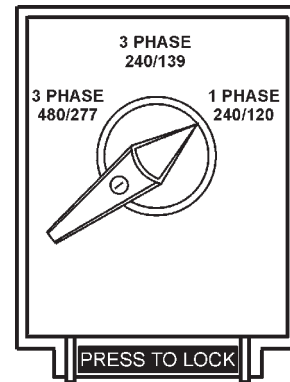

Figure 30. Voltage Selector Switch 240/120V Single-Phase Position

2. Connect the load wires to the UVWO terminals as shown in Figure 31.

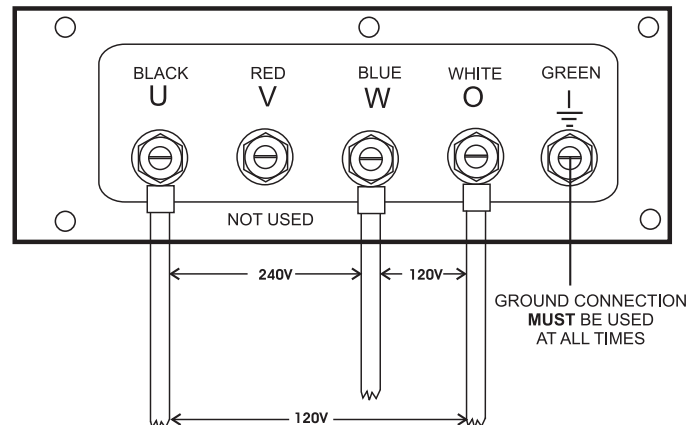

Figure 31. UVWO Terminal Lugs 1Ø-240V/120V Connections

3. Turn the voltage regulator knob (Figure 32) clockwise to increase voltage output, turn counterclockwise to decrease voltage output.



Figure 32. Voltage Regulator Knob (1Ø-240/120V)

Circuit Breakers

To protect the generator from an overload, a 3-pole, 110 amp, **main** circuit breaker is provided to protect the UVW output terminals from overload. In addition two single-pole, 20 amp **GFCI** circuit breakers are provided to protect the GFCI receptacles from overload. Three 50 amp **load** circuit breakers have also been provided to protect the auxiliary receptacles from overload. Make sure to switch **ALL** circuit breakers to the "OFF" position prior to starting the engine.

Lubrication Oil

Fill the engine crankcase with lubricating oil through the filler hole, but **DO NOT** overfill. Make sure the generator is level. and verify that the oil level is maintained between the two notches (Figure 33) on the dipstick. See Table 11 for proper selection of engine oil.

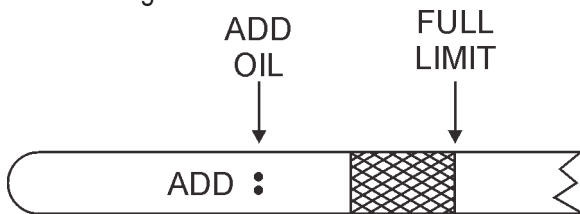

Figure 33. Engine Oil Dipstick

When checking the engine oil, be sure to check if the oil is clean. If the oil is not clean, drain the oil by removing the oil drain plug, and refill with the specified amount of oil as outlined in the **Isuzu Engine Owner's Manual**. Oil should be warm before draining.

Other types of motor oils may be substituted if they meet the following requirements:

- API Service Classification CH-4
- API Service Classification CG-4
- API Service Classification CF-4
- ACEA Specification E3
- ACEA Specification E2

Table 11. Recommended Motor Oil

Temperature Range	Type Oil
77°F and greater (25°C and greater)	SAE15W-40 or SAE40
32°F to 77°F (0°C to 25°C)	SAE 10W-30 or SAE30
-22°F to -32°F (-30°C to 0°C)	SAE10W-30 or SAE10

Fuel Check **DANGER:**



Fuel spillage on a **hot!** engine can cause a **fire** or **explosion**. If fuel spillage occurs, wipe up the spilled fuel completely to prevent fire hazards. **NEVER!** smoke around or near the generator.



Refilling the Fuel System

The DCA45SSJU genset may (if equipped with a trailer or skid) have a **double fuel tank system** (Figure 34), which consists of an **internal** generator fuel tank, and a **trailer mounted** fuel tank. It is also possible the genset can be equipped with a **skid mounted** fuel tank (Figure 5). The skid type fuel system does not use the internal generator fuel tank.

Use the instructions in this section that applies to your type of fuel tank system.

ALWAYS fill the fuel tank with clean and fresh **#2 diesel fuel**. **DO NOT** fill the fuel tanks beyond their capacities.

Pay attention to the fuel tank capacity when replenishing fuel. The fuel tank cap must be closed tightly after filling. Handle fuel in a safety container. If the container does not have a spout, use a funnel. Wipe up any spilled fuel immediately.

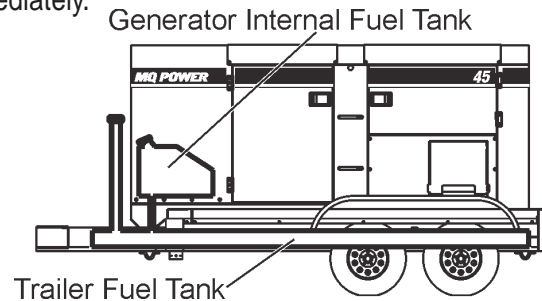

Figure 34. Double Fuel Tank System

WARNING:



ONLY properly trained personel who have read and understand this section should refill the double fuel tank system.
Use **#2 diesel fuel**.

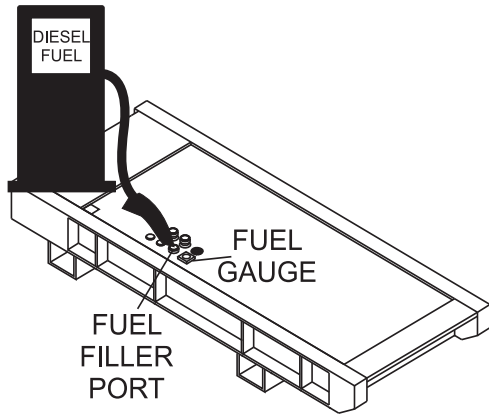

Figure 35. Skid Type Fuel Tank System

Refueling Procedure:

DANGER:



Diesel fuel and its vapors are dangerous to your health and the surrounding environment. Avoid skin contact and/or inhaling fumes.



1. **Level Tanks** – make sure fuel cells are level with the ground. Failure to do so will cause fuel to spill from the tank before reaching full capacity. See Figure 36.

WARNING:



ALWAYS! place trailer on firm level ground before refueling.

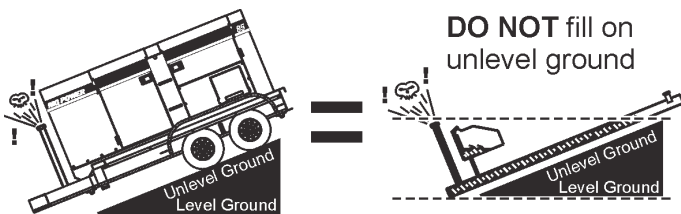

Figure 36. Only Fill on Level Ground

2. **Trailer Fuel Tank First** – The trailer fuel tank is the primary fuel tank and holds a larger capacity of fuel. The fuel in the trailer will be filtered and sent to the engine. **ALWAYS** fill trailer fuel tank (Figure 37) first.

CAUTION:



ALWAYS! fill trailer tank *first* with **#2 diesel fuel**, before filling secondary internal tank.

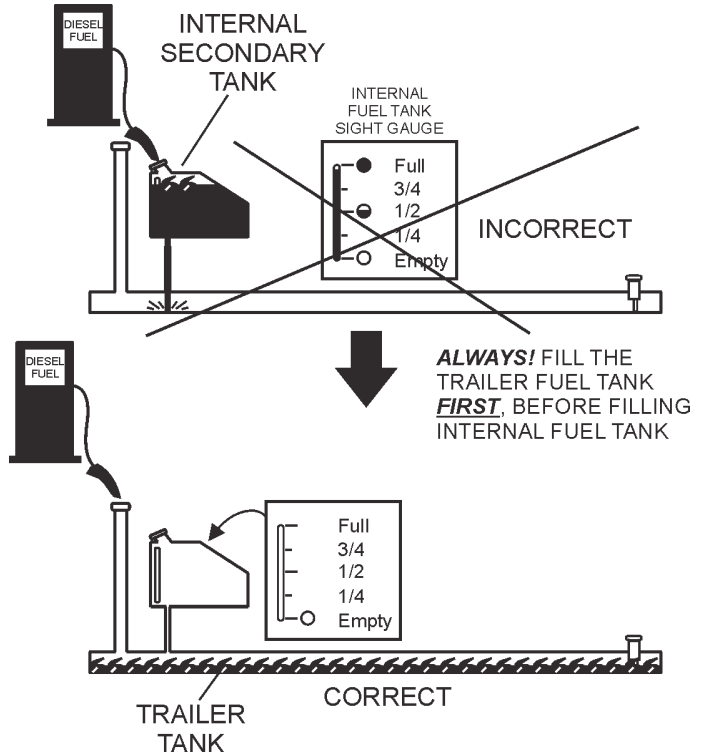
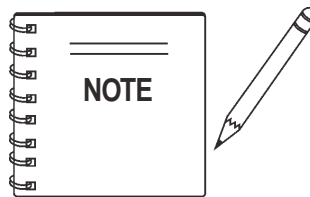
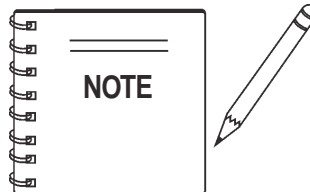

Figure 37. Fuel Tank Filling Order



ONLY! use **#2 diesel fuel** when refueling.



Fuel from the secondary inner tank will eventually drain into the primary trailer tank.

3. **NEVER overfill trailer fuel tank** – It is important to read the trailer fuel gauge when filling trailer fuel tank. **DO NOT** wait for fuel to rise in filler neck. See Figure 38.

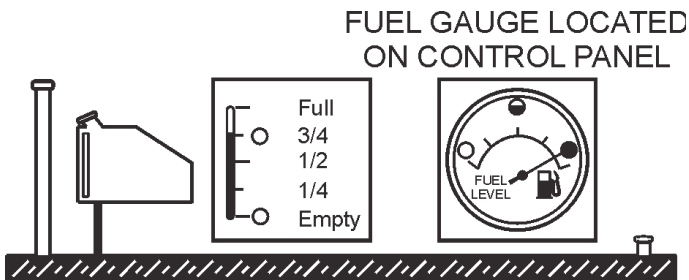

Figure 38. Full Trailer Tank

5. Figure 40 below reflects a full fuel system.

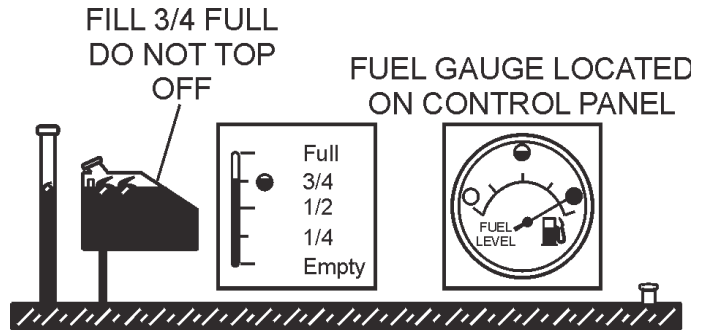

Figure 40. Full Fuel System

WARNING:



DO NOT OVER-FILL fuel system. Leave room for fuel expansion. Fuel expands when heated.

4. Once the trailer tank is full, the **secondary inner tank** can be filled (See Figure 39). Notice how the trailer filler tube level rises when the internal tank is filled.

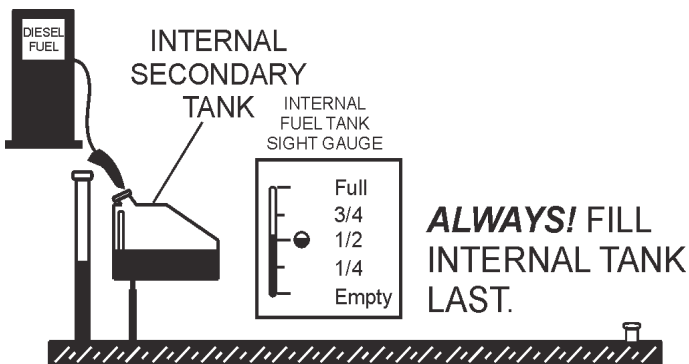

Figure 39. Filling Secondary Internal Fuel Tank

6. Fuel from the engine return line will drain into the secondary internal fuel tank. This fuel will eventually drain into the primary trailer tank in order to return to the engine.

WARNING:



It is recommended to only fill the internal secondary tank to 3/4 full in order to allow for fuel return, fuel expansion, and to avoid spillage. See Figure 41 for fuel expansion.

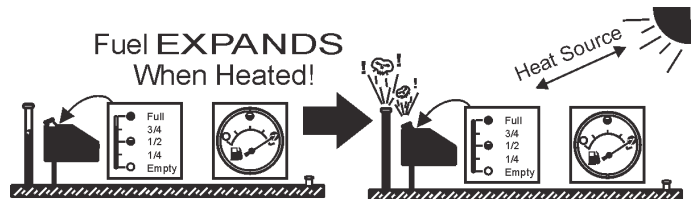

Figure 41. Fuel Expansion

Coolant (Ethylene Glycol [Green] / Water — 50/50 mix)

Use only drinkable tap water. If hard water or water with many impurities is used, the inside of the engine and radiator may become coated with deposits and cooling efficiency will be reduced.

An anticorrosion additive added to the water will help prevent deposits and corrosion in the cooling system. See the engine manual for further details.

CAUTION:



If adding coolant/antifreeze mix to the radiator, **DO NOT** remove the radiator cap until the unit has completely cooled. The possibility of **hot!** coolant exists which can cause severe burns.



Day-to-day addition of coolant is done from the recovery tank. When adding coolant to the radiator, **DO NOT** remove the radiator cap until the unit has completely cooled. See Table 12 for engine, radiator, and recovery tank coolant capacities. Make sure the coolant level in the recovery tank is always between the "H" and the "L" markings.

Table 12. Coolant Capacity

Engine and Radiator	5.3 Gal. (20 L)
Reserve Tank	0.26 Gal. (1L)

Operation Freezing Weather

When operating in freezing weather, be certain the proper amount of antifreeze (Table 13) has been added.

Table 13. Anti-Freeze Operating Temperatures

Vol % Anti-Freeze	Freezing Point		Boiling Point	
	°C	°F	°C	°F
40	-24	-12	106	222
50	-37	-34	108	226

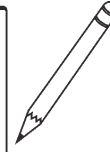
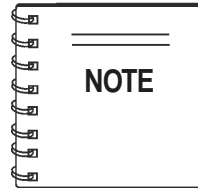

When the antifreeze is mixed with water, the antifreeze mixing ratio **must be** less than 50%.

Cleaning the Radiator

The engine may overheat if the radiator fins become overloaded with dust or debris. Periodically clean the radiator fins with compressed air. Cleaning inside the machine is dangerous, so clean only with the engine turned off and the **negative** battery terminal disconnected.

Air Cleaner

Periodic cleaning/replacement is necessary. Inspect it in accordance with the **Isuzu Engine Owner's Manual**.

Fan Belt Tension

A slack fan belt may contribute to overheating, or to insufficient charging of the battery. Inspect the fan belt for damage and wear and adjust it in accordance with the **Isuzu Engine Owner's Manual**.

The fan belt tension is proper if the fan belt bends 10 to 15 mm (Figure 42) when depressed with the thumb as shown below.

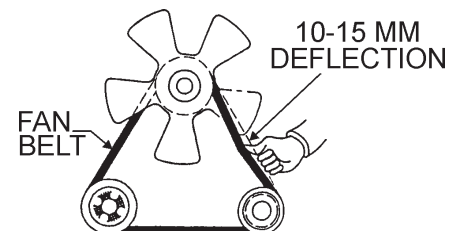

Figure 42. Fan Belt Tension

CAUTION:



NEVER! place hands near the belts or fan while the generator set is running.



Battery

This unit is of negative ground **DO NOT** connect in reverse. Always maintain battery fluid level between the specified marks. Battery life will be shortened, if the fluid level are not properly maintained. Add only distilled water when replenishment is necessary.

DO NOT over fill. Check to see whether the battery cables are loose. Poor contact may result in poor starting or malfunctions. **Always** keep the terminals firmly tightened. Coating the terminals with an approved battery terminal treatment compound. Replace battery with only recommended type battery. The battery type used in this generator is BCI Group 27.

The battery is sufficiently charged if the specific gravity of the battery fluid is 1.28 (at 68° F). If the specific gravity should fall to 1.245 or lower, it indicates that the battery is dead and needs to be recharged or replaced.

Battery Cable Installation

ALWAYS be sure the battery cables (Figure 43) are properly connected to the battery terminals as shown below. The **RED** cable is connected to the positive terminal of the battery, and the **BLACK** cable is connected to the negative terminal of the battery.

CAUTION:



ALWAYS disconnect the negative terminal **FIRST** and reconnect negative terminal **LAST**.

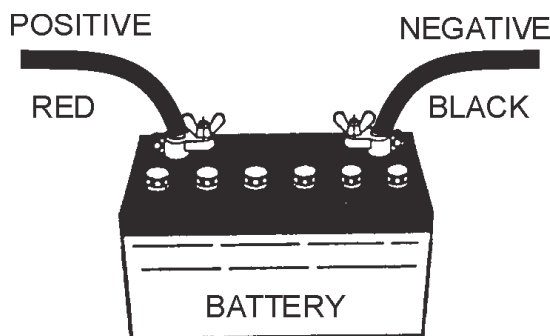
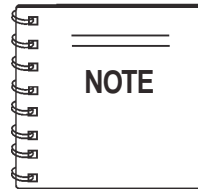

Figure 43. Battery Connections

When connecting battery do the following:

1. **NEVER** connect the battery cables to the battery terminals when the **ignition** switch is in either the **Pre-Heat, RUN, or START** position. **ALWAYS** make sure that the ignition switch is in the **STOP** position when connecting the battery.
2. Place a small amount of battery terminal treatment compound around both battery terminals. This will ensure a good connection and will help prevent corrosion around the battery terminals.



If the battery cable is connected incorrectly, electrical damage to the generator will occur. Pay close attention to the polarity of the battery when connecting the battery.

CAUTION:



Inadequate battery connections may cause poor starting of the generator, and create other malfunctions.

Alternator

The polarity of the alternator is negative grounding type. When an inverted circuit connection takes place, the circuit will be in short circuit instantaneously resulting the alternator failure.

DO NOT put water directly on the alternator. Entry of water into the alternator leads an electrolyte corrosion causing an alternator failure.

Before charging the battery with an external electric source, be sure to disconnect the battery cables.

Wiring

Inspect the entire generator for bad or worn electrical wiring or connections. If any wiring or connections are exposed (insulation missing) replace wiring immediately.

Piping and Hose Connection

Inspect all piping, oil hose, and fuel hose connections for wear and tightness. Tighten all hose clamps and check hoses for leaks.

If any hose (**fuel** or **oil**) lines are defective replace them immediately.

DCA-45SSIU2 — GENERATOR START-UP PROCEDURE

WARNING:



The engine's exhaust contains harmful emissions. **ALWAYS have adequate ventilation when operating.** Direct exhaust away from nearby personnel.

BEFORE STARTING

Generator and Control Panel

CAUTION:



NEVER! manually start the engine with the main, GFCI or auxiliary circuit breakers in the "ON" (closed) position.

1. Be sure and place the **main, G.F.C.I.** and **aux.** circuit breakers (Figure 44) in the "OFF" position prior to starting the engine.

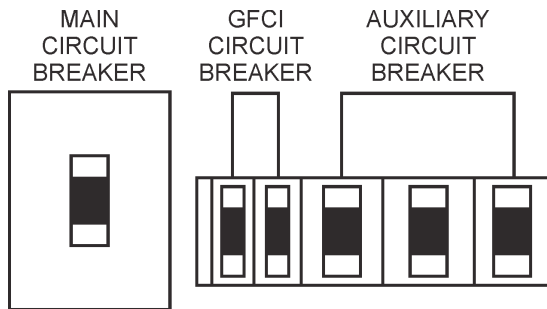

Figure 44. Main, Aux. and GFCI Circuit Breakers

2. Connect the load to the **UVWO** terminals or **auxiliary receptacles** as shown in Figure 45. These load connection points can be found on the output terminal panel. To gain access to the UVWO terminals or other power receptacles, unlock the access cover and lift the door.

The UVWO terminals are protected by a plastic cover, remove this cover to gain access to the terminals. Tighten terminal nuts securely to prevent load wires from slipping out.

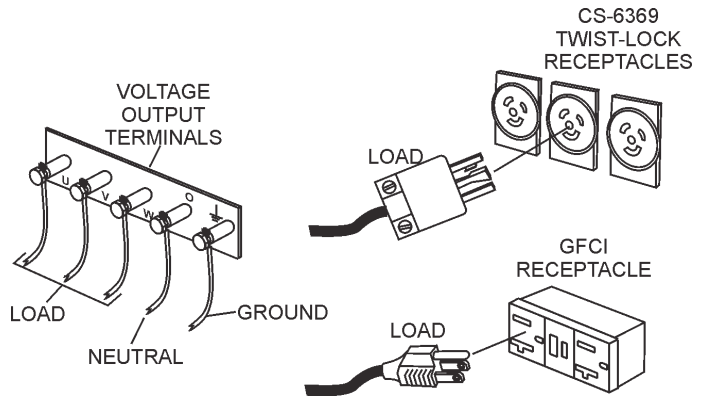

Figure 45. Load Connections

3. Close all engine enclosure doors (Figure 46).

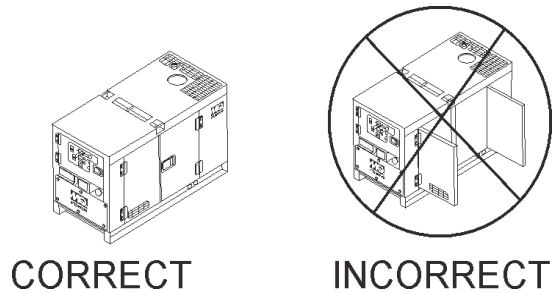

Figure 46. Engine Enclosure Doors

4. Place the voltage selector switch in the desired voltage position (Figure 47).

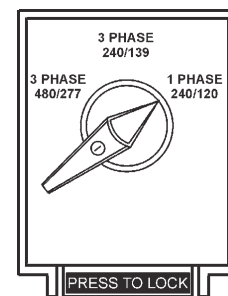

Figure 47. Voltage Selector Switch

DCA-45SSIU2 — GENERATOR START-UP PROCEDURE

5. Push the engine throttle control lever inward (Figure 48) to the “**LOW**” position.

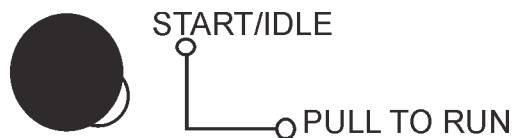

Figure 48. Engine Throttle Control Lever (Low)

6. Preheat the engine **glow plugs** by turning the ignition key (Figure 49) to the “**PRE-HEAT**” position.

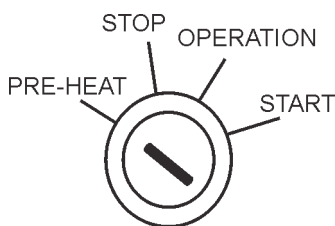

Figure 49. Ignition Switch (Pre-Heat Position)

7. When the preheat lamp luminates (Figure 50), turn the ignition key to the “**START**” position. Once the engine starts, release the ignition key and allow it to return to the “**OPERATION**” position (Figure 49).



Figure 50. Pre-Heat Indicator Lamp

8. Let the engine idle for 3-5 minutes, listen and check for any abnormal sounds or smells. Check for fuel leaks, and noises that would associate with a loose cover or hardware. If any of the above mentioned conditions exists, shut-down the engine and correct the problem.
9. If the engine is running smoothly with no problems, pull and place the engine throttle lever (Figure 51) in the “**HIGH**” position”.

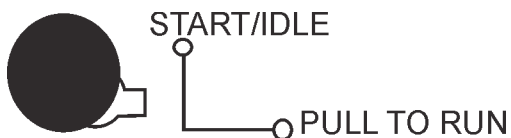

Figure 51. Engine Throttle Control Lever (High)

10. The generator's frequency meter (Figure 52) displays the 60 cycle output frequency in **HERTZ**.

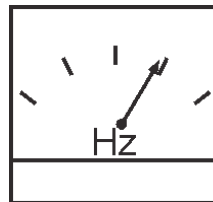

Figure 52. Frequency Meter (Hz)

11. The generator's voltage meter (Figure 53) displays the 120 VAC in **VOLTS**. If the voltage is not within the specified frequency tolerance,

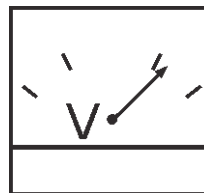

Figure 53. AC Voltmeter

12. Use the voltage adjustment control knob (Figure 54) to increase or decrease the desired voltage.



Figure 54. Voltage Adjust Control Knob

13. The ammeter (Figure 55) will indicate zero amps with no load applied. When a load is applied, this meter will indicate the amount of current that the load is drawing from the generator.

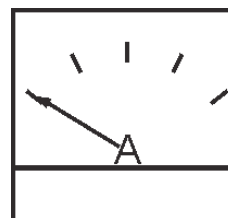

Figure 55. Ammeter (No Load)

DCA-45SSIU2 — GENERATOR START-UP PROCEDURE

14. The engine oil pressure gauge (Figure 56) will indicate the oil pressure (kg/ cm²) of the engine. Under normal operating conditions the oil pressure is approximately

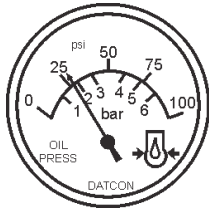

Figure 56. Oil Pressure Gauge

15. The coolant temperature gauge (Figure 57) will indicate the coolant temperature. Under normal operating conditions the coolant temperature is between 165 and 215 degrees Fahrenheit.

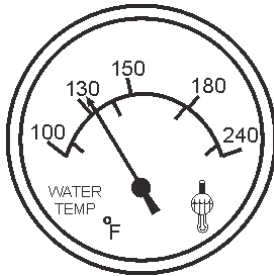

Figure 57. Coolant Temperature Gauge

16. The tachometer (Figure 58) will indicate the speed of the engine when the generator is operating. Under normal operating conditions this speed is approximately 1800 RPM's.

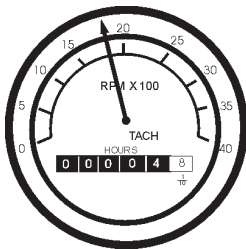

Figure 58. Engine Tachometer

17. Turn the **main**, **GFCI**, and **aux.** circuit breakers to the “ON” position (Figure 59).

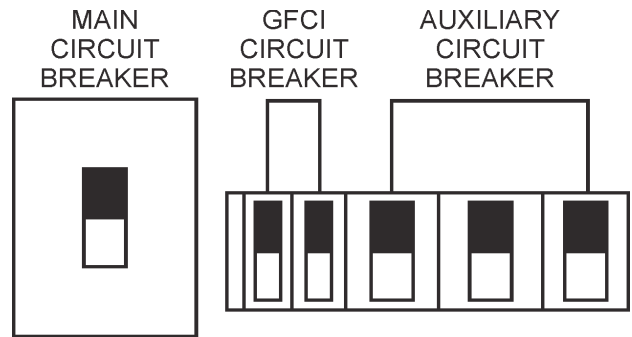

Figure 59. Main, AUX. and GFCI Circuit Breakers (ON)

18. Observe the generator's ammeter (Figure 60) and verify it reads the anticipated amount of current with respect to the load. The ammeter will only display a current reading if the load is in use.

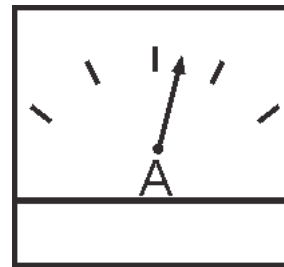

Figure 60. Ammeter (Load)

19. The generator will run until manually stopped or an abnormal condition occurs.

DCA-45SSIU2 — GENERATOR SHUT-DOWN PROCEDURE

NORMAL SHUT-DOWN

To shutdown the generator, use the following procedure:

1. Switch the **MAIN**, **AUX** and **GFCI** circuit breakers (Figure 61) to the “**OFF**” position (no load).

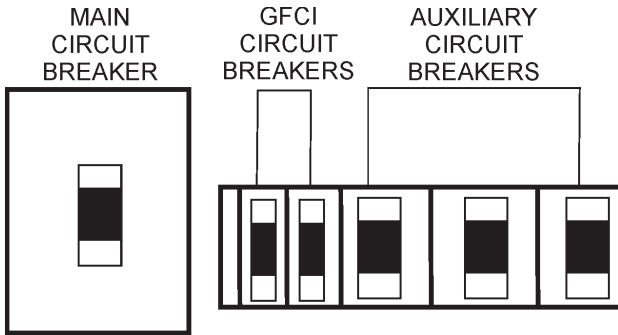

Figure 61. Main, AUX. and GFCI Circuit Breakers (OFF)

2. Push the engine throttle control lever inward (Figure 62) to the “**LOW**” position.

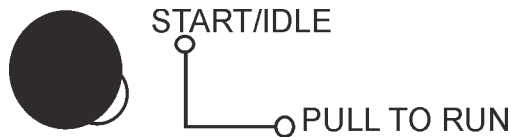

Figure 62. Engine Throttle Control Lever (Low)

3. Let the engine cool by running it for 3-5 minutes with no load applied (circuit breakers in the off position).
4. Place the ignition switch (Figure 63) in the “**STOP**” position, remove the key and store in a safe place.

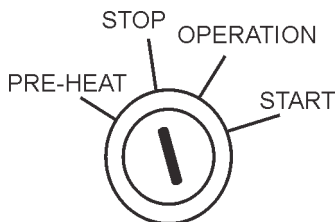

Figure 63. Ignition Switch (Off Position)

5. Remove ***all*** loads from the generator.

EMERGENCY SHUT-DOWN

1. To shut-down the engine in the event of an emergency, switch the **MAIN**, **GFCI** and **LOAD** (Figure 61) circuit breakers to “**OFF**” position.
2. Turn the ignition switch key to the “**STOP**” position.

DCA-45SSIU2 — GENERATOR/ENGINE MAINTENANCE

TABLE 14. INSPECTION/MAINTENANCE		10 Hrs DAILY	250 Hrs	500 Hrs	1000 Hrs
ENGINE	Check Engine Fluid Levels	X			
	Check Air Cleaner	X			
	Check Battery Acid Level	X			
	Check Fan Belt Condition	X			
	Check for Leaks	X			
	Check for Loosening of Parts	X			
	Replace Engine Oil and Filter *1		X		
	Clean Air Filter		X		
	Drain Bottom of Fuel Tank		X		
	Clean Unit, Inside and Outside		X		
	Change Fuel Filter *2			X	
	Clean Radiator and Check Coolant Protection Level			X	
	Test Fuel Injection Nozzle			X	
	Replace Air Filter Element				X
	Check all Hoses and Clamps				X
	Check Valve Clearance				X
Check Injection Nozzle			X	X	
Clean Inside of Fuel Tank				X	
GENERATOR	Measure Insulation Resistance Over 3M ohms		X		

*1 Replace engine oil and filter at 100 hours, first time only.

*2 Replace fuel filter at 250 Hours, first time only.

General Inspection

Prior to each use, the generator should be cleaned and inspected for deficiencies. Check for loose, missing or damaged nuts, bolts or other fasteners. Also check for fuel, oil, and coolant leaks.

Engine Side (Refer to the Engine Instruction Manual)

Air Cleaner

Every 50 hours: Remove air cleaner element and clean the heavy duty paper element with kerosene, or foam element with liquid detergent and hot water. Wrap foam element in a cloth and squeeze dry. For heavy duty paper element, wipe excess kerosene with towel.

Air Cleaner with Dust Indicator

This indicator is attached to the air cleaner. When the air cleaner element is clogged, air intake restriction becomes greater and the dust indicator signal shows "RED" meaning the element needs changing. After changing the air element, press the dust indicator button to reset the indicator.

Service Daily

If the engine is operating in very **dusty** or **dry grass** conditions, a clogged air cleaner will result. This can lead to a loss of power, excessive carbon buildup in the combustion chamber and high fuel consumption. Change air cleaner more **frequently** if these conditions exist.

Fuel Addition

Add diesel fuel (the grade may vary according to season and locations). Always pour through the mesh filter.

Removing Water from the Fuel Tank

After prolonged use, water and other impurities accumulate in the bottom of the tank. Occasionally remove the drain cock and drain the contents. During cold weather, the more empty volume inside the tank, the easier it is for water to condense. This can be reduced by keeping the tank full with diesel fuel.

Air Removal

If air enters the fuel injection system of a diesel engine, starting becomes impossible. After running out of fuel, or after disassembling the fuel system, bleed the system according to the following procedure.

To restart after running out of fuel, turn the switch to the "ON" position for 15-30 seconds. Try again, if needed. This unit is equipped with an automatic air bleeding system.

Cleaning the Fuel Strainer

Clean the fuel strainer if it contains dust or water. Remove dust or water in the strainer cap and wash it in gasoline. Securely fasten the fuel strainer cap so that fuel will not leak. Check the fuel strainer every 200 hours of operation or once a month.

Check Oil Level

Check the crankcase oil level prior to each use, or when the fuel tank is filled. Insufficient oil may cause severe damage to the engine. Make sure the generator is level. The oil level must be between the two notches on the dipstick as shown in Figure 33.

Replacing Oil Filter

- Detach the oil filter by loosening center bolt and remove the element together with the filter body.
- Apply a film of oil to the gasket for the cartridge.
- Install the filter body together with the element and fix them by tightening the center bolt.
- After the oil cartridge has been replaced, the engine oil will drop slightly. Run the engine for a while and check for leaks before adding more oil if needed. Clean excessive oil from engine.

Replacing Fuel Filter

- Replace the fuel filter cartridge with new one every 400 hours or so.
- Loosen the drain plug at the lower top of the fuel filter. Drain the fuel in the fuel body together with the mixed water. **DO NOT** spill the fuel during disassembly.
- Vent any air.

Feed Pump Strainer Cleaning

The strainer is incorporated in the feed pump inlet side joint bolt. Clean the strainer with compressed air and rinse it in the fuel oil.

Flushing Out Radiator and Replacing Coolant

- Open both cocks located at the crankcase side and at the lower part of the radiator and drain coolant. Open the radiator cap while draining. Remove the overflow tank and drain.
- Check hoses for softening and kinks. Check clamps for signs of leakage.
- Flush the radiator by running clean tap water through radiator until signs of rust and dirt are removed. **DO NOT** clean radiator core with any objects, such as a screwdriver.
- Tighten both cocks and replace the overflow tank.
- Replace with coolant (Table 12 for correct mixture).
- Close radiator cap tightly.

CAUTION:



Allow engine to **cool** when flushing out radiator. Flushing the radiator while **hot!** will damage radiator.

Generator Storage

For long term storage of the generator the following is recommended:

- Fill the fuel tank completely. Treat with a fuel stabilizer if necessary.
- Completely drain the oil from the crankcase and refill if necessary with fresh oil.
- Clean the entire generator, internal and external.
- Cover the generating set and store in a clean, dry place.
- Disconnect the battery.
- Make sure engine coolant is at proper level.
- If generator is mounted on a trailer, jack trailer up and place on block so tires do touch the ground or remove tires.

Jacket Water Heater and Internal Battery Charger 120 VAC Input Plugs (OPTIONAL)

This generator is equipped with two 120 VAC, 20 amp input plugs located on the output terminal panel.

The purpose of these plugs is to provide power via commercial power to the **jacket water heater** and **internal battery charger**.

These plugs will **ONLY** function when commercial power has been supplied to them (Figure 64). To apply commercial power to these plugs, a power cord of adequate size will be required (See Table 5).

When using the generator in **hot** climates there is no reason to apply power to jacket water heater. However, if the generator will be used in **cold** climates it is always a good idea to apply power to the jacket water heater at all times. To apply power to the jacket water heater, simply apply power to the **jacket water heater plug** via commercial power using a power cord of adequate size.

If the generator will be used daily, the battery should normally not require charging. If the generator will be idle (not used) for long periods of time, apply power to the **battery charger plug** via commercial power using a power cord of adequate size.

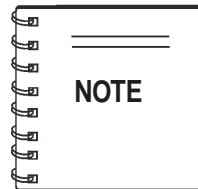

To ensure adequate starting capability, **always** have power applied to the generator's **internal battery charger**.

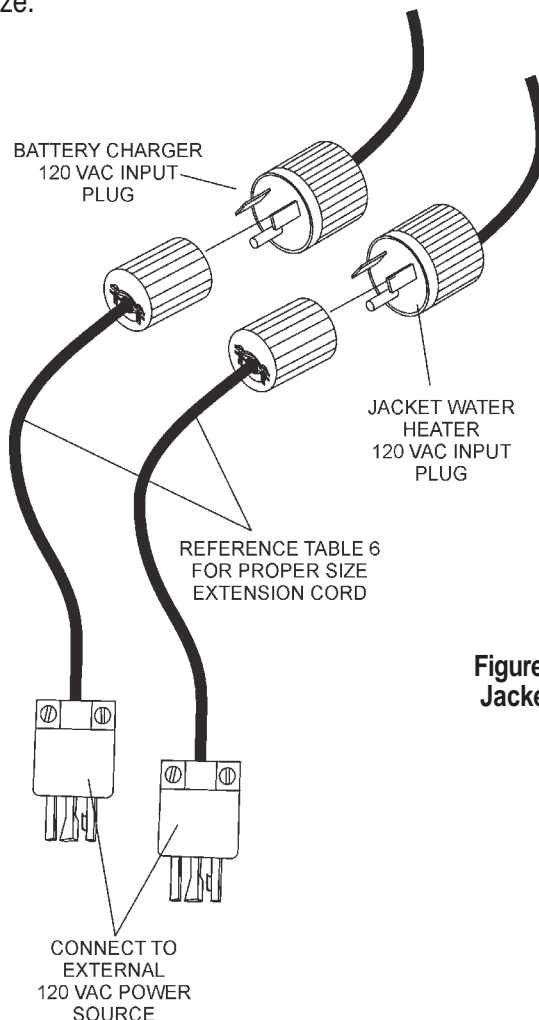

Figure 64. DCA-45SIU2 Battery Charger & Jacket Water Heater Power Connections

DCA-45SSIU2 — TRAILER BRAKES MAINTENANCE

Brakes

Trailer brakes should be inspected the **first 200 miles** of operation. This will allow the brake shoes and drums to seat properly. After the first 200 mile interval, inspect the brakes **every 3,000 miles**. If driving over rough terrain, inspect the brakes more frequently.

Figure 74 displays the major hydraulic surge brake components that will require inspection and maintenance. Please inspect these components as required using steps 1 through 8 as listed below:

Brake Adjustment

1. Place the trailer on jack stands. Make sure the jack stands are placed on secure level ground.
2. Check the wheel and drum for free rotation.
3. Remove the adjusting hole cover from the adjusting slot at the bottom brake backing plate.
4. With a screwdriver or standard adjusting tool, rotate the star wheel of the adjuster assembly to expand the brake shoes.
5. Adjust the brake shoes outward until the pressure of the lining against the wheel drum makes the wheel difficult to turn.
6. Adjust, rotate the star wheel in the opposite direction until the wheel rotates freely with slight lining drag.
7. Replace the adjusting hole cover and lower the trailer to the ground.
8. Repeat steps 1 through 7 on the remaining brakes.

Hydraulic Surge Brakes

Hydraulic surge brakes (Figure 65) should not require any special attention with the exception of routine maintenance such as shoe and lining replacement. Brake lines should be periodically checked for cracks, kinks, or blockage.

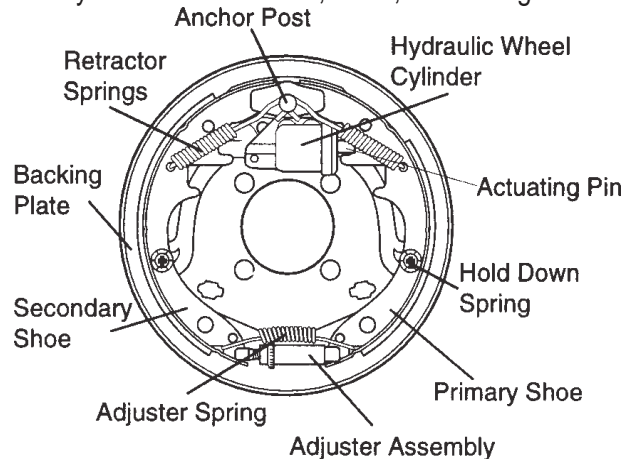

Figure 65. Hydraulic Brake Components

Actuator

Hydraulic surge braking requires the installation of an actuator at the tongue of the trailer. Remember the **surge** or **push** of the trailer toward the tow vehicle automatically synchronizes the trailer brakes with the tow vehicle brakes. As the trailer pushes against the tow vehicle the actuator telescopes together and applies force to the master cylinder, supplying hydraulic pressure to the trailer brakes.

Periodically check and test the surge **“actuator”** to make sure that it is functioning correctly. Never use an undersize actuator.

Table 15. Hydraulic Brake Troubleshooting

Symptom	Possible Cause	Solution
No Brakes	Brake line broken or kinked?	Repair or replace.
Weak Brakes or Brakes Pull to One Side	Brake lining glazed?	Reburnish or replace.
	Trailer overloaded?	Correct weight.
	Brake drums scored or grooved?	Machine or replace.
	Tire pressure correct?	Inflate all tires equally.
	Tires unmatched on the same axle?	Match tires.
Locking Brakes	Brake components loose, bent or broken?	Replace components.
	Brake drums out-of-round?	Replace.
Noisy Brakes	System lubricated?	Lubricate.
	Brake components correct?	Replace and correct.
Dragging Brakes	Brake lining thickness incorrect or not adjusted correctly?	Install new shoes and linings.
	Enough brake fluid or correct fluid?	Replace rubber parts fill with dot 4 fluid.

Tires/Wheels/Lug Nuts

Tires and wheels are a very important and critical components of the trailer. When specifying or replacing the trailer wheels it is important the wheels, tires, and axle are properly matched.

CAUTION:



DO NOT attempt to repair or modify a wheel. **DO NOT** install in inner tube to correct a leak through the rim. If the rim is cracked, the air pressure in the inner tube may cause pieces of the rim to explode (break off) with great force and cause serious eye or bodily injury.

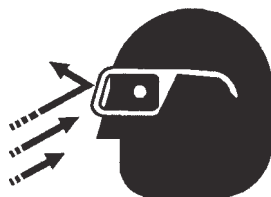

Tire Wear/Inflation

Tire inflation pressure is the most important factor in tire life. Pressure should be checked cold before operation **DO NOT** bleed air from tires when they are *hot!* Check inflation pressure weekly during use to insure the maximum tire life and tread wear.

Table 16 (Tire Wear Troubleshooting) will help pinpoint the causes and solutions of tire wear problems.

TABLE 16 TIRE WEAR TROUBLESHOOTING		
WEAR PATTERN	CAUSE	SOLUTION
Center Wear	Over Inflation.	Adjust pressure to particular load per tire manufacturer.
Edge Wear	Under Inflation.	Adjust pressure to particular load per tire manufacturer.
Side Wear	Loss of camber or overloading.	Make sure load does not exceed axle rating. Align wheels.
Toe Wear	Incorrect toe-in.	Align wheels.
Cupping	Out-of-balance.	Check bearing adjustment and balance tires.
Flat Spots	Wheel lockup & tire skidding.	Avoid sudden stops when possible and adjust brakes.

Suspension

The *leaf suspension* springs and associated components (Figure 66) should be visually inspected every 6,000 miles for signs of excessive wear, elongation of bolt holes, and loosening of fasteners. Replace all damaged parts (suspension) immediately. Torqued suspension components as detailed in Table 17.

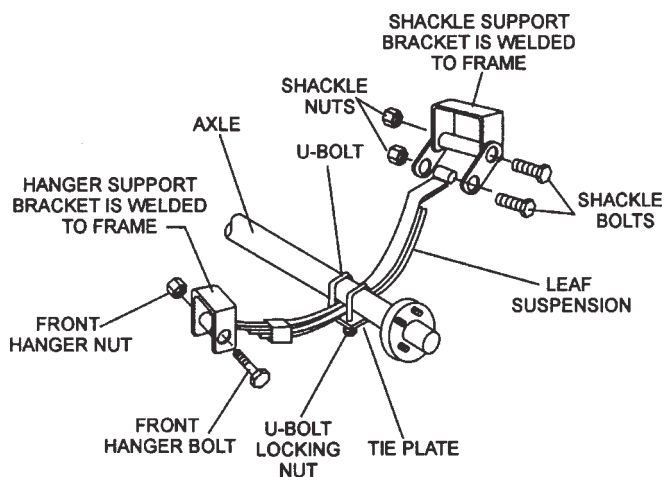

Figure 66. Major Suspension Components

Table 17. Suspension Torque Requirements

Item	Torque (Ft.-Lbs.)
3/8" U-BOLT	MIN-30 MAX-35
7/16" U-BOLT	MIN-45 MAX-60
1/2" U-BOLT	MIN-45 MAX-60
SHACKLE BOLT SPRING EYE BOLT	SNUG FIT ONLY. PARTS MUST ROTATE FREELY. LOCKING NUTS OR COTTER PINS ARE PROVIDED TO RETAIN NUT-BOLT ASSEMBLY.
SHOULDER TYPE SHACKLE BOLT	MIN-30 MAX-50

CAUTION:



ALWAYS wear safety glasses when removing or installing force fitted parts. Failure to comply may result in serious injury.

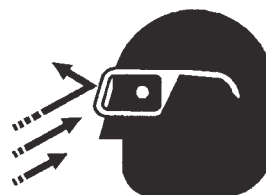

Lug Nut Torque Requirements

It is extremely important to apply and maintain proper wheel mounting torque on the trailer. Be sure to use only the fasteners matched to the cone angle of the wheel. Proper procedure for attachment of the wheels is as follows:

1. Start all wheel lug nuts by hand.
2. Torque all lug nuts in sequence. See Figure 67. **DO NOT** torque the wheel lug nuts all the way down. Tighten each lug nut in 3 separate passes as defined by Table 18.
3. After first road use, retorque all lug nuts in sequence. Check all wheel lug nuts periodically.

Table 18. Tire Torque Requirements

Wheel Size	First Pass FT-LBS	Second Pass FT-LBS	Third Pass FT-LBS
12"	20-25	35-40	50-65
13"	20-25	35-40	50-65
14"	20-25	50-60	90-120
15"	20-25	50-60	90-120
16"	20-25	50-60	90-120

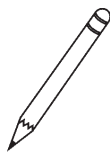
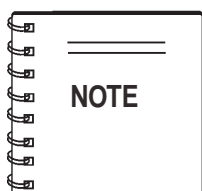

NEVER use an pneumatic air gun to tighten wheel lug nuts.

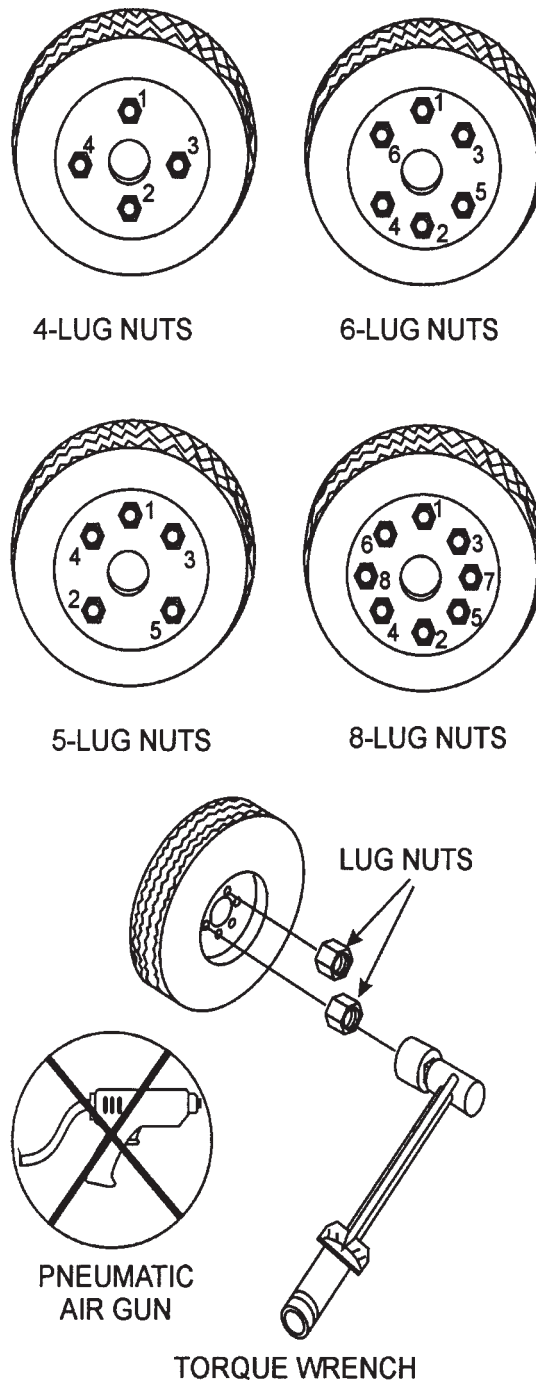

Figure 67. Wheel Lug Nuts Tightening Sequence

DCA-45SSIU2 — TRAILER WIRING DIAGRAM

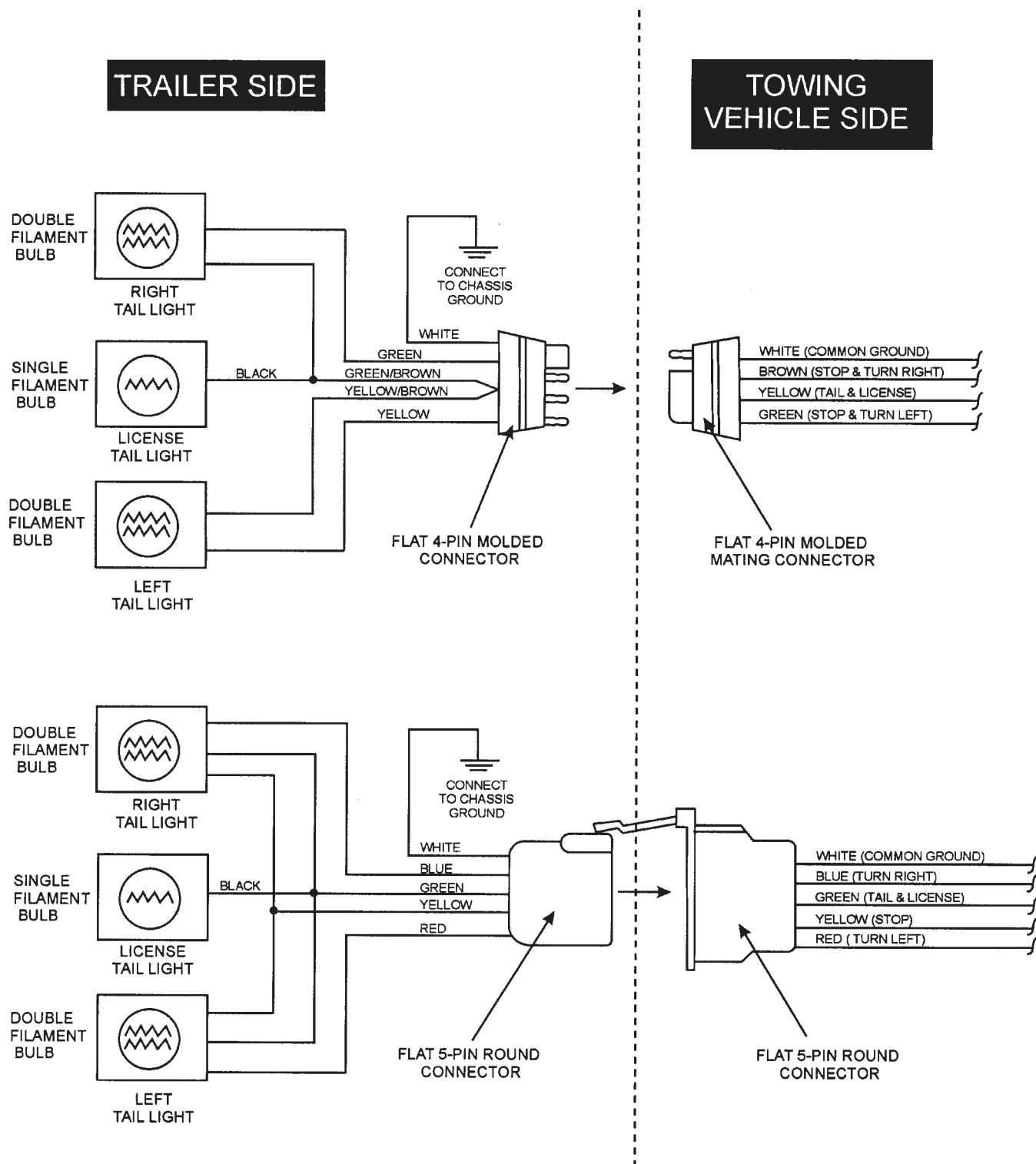
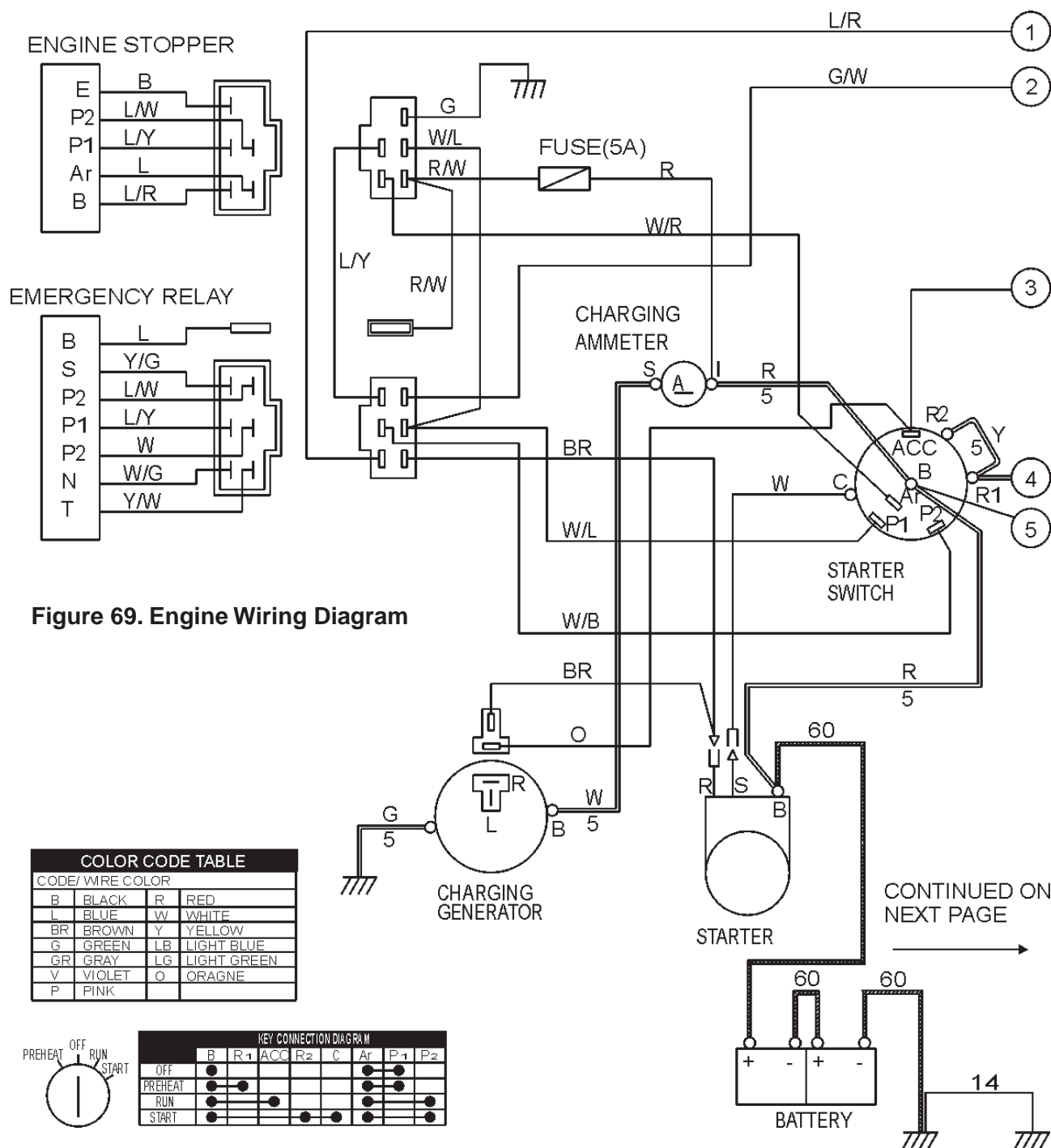

Figure 68. Trailer/Towing Vehicle Wiring Diagram

DCA-45SSIU2 — ENGINE WIRING DIAGRAM

DCA45SSIU2 STANDARD
ENGINE WIRE DIAGRAM



DCA-45SSIU2 — ENGINE WIRING DIAGRAM

DCA45SSIU2 STANDARD
ENGINE WIRE DIAGRAM

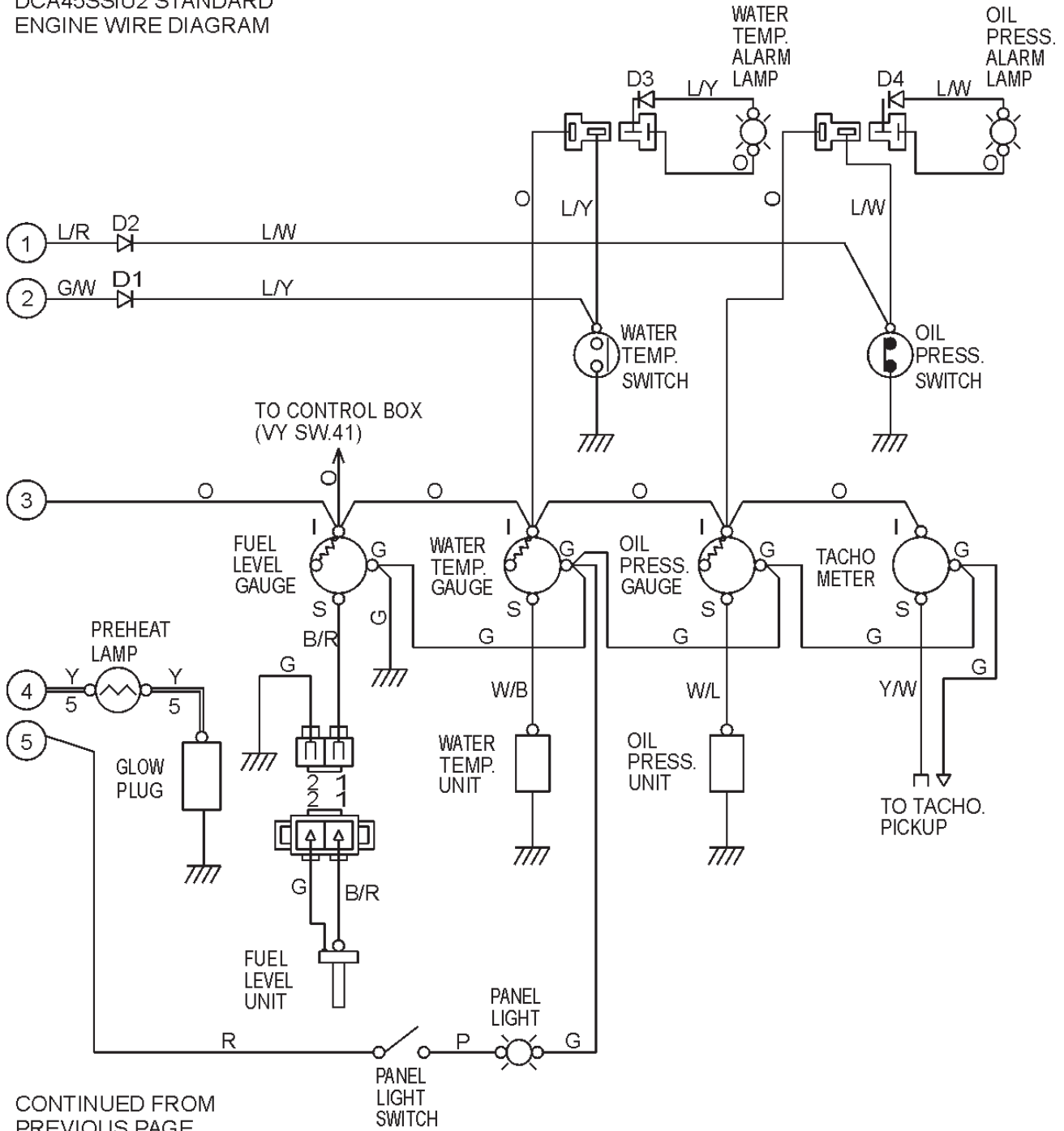
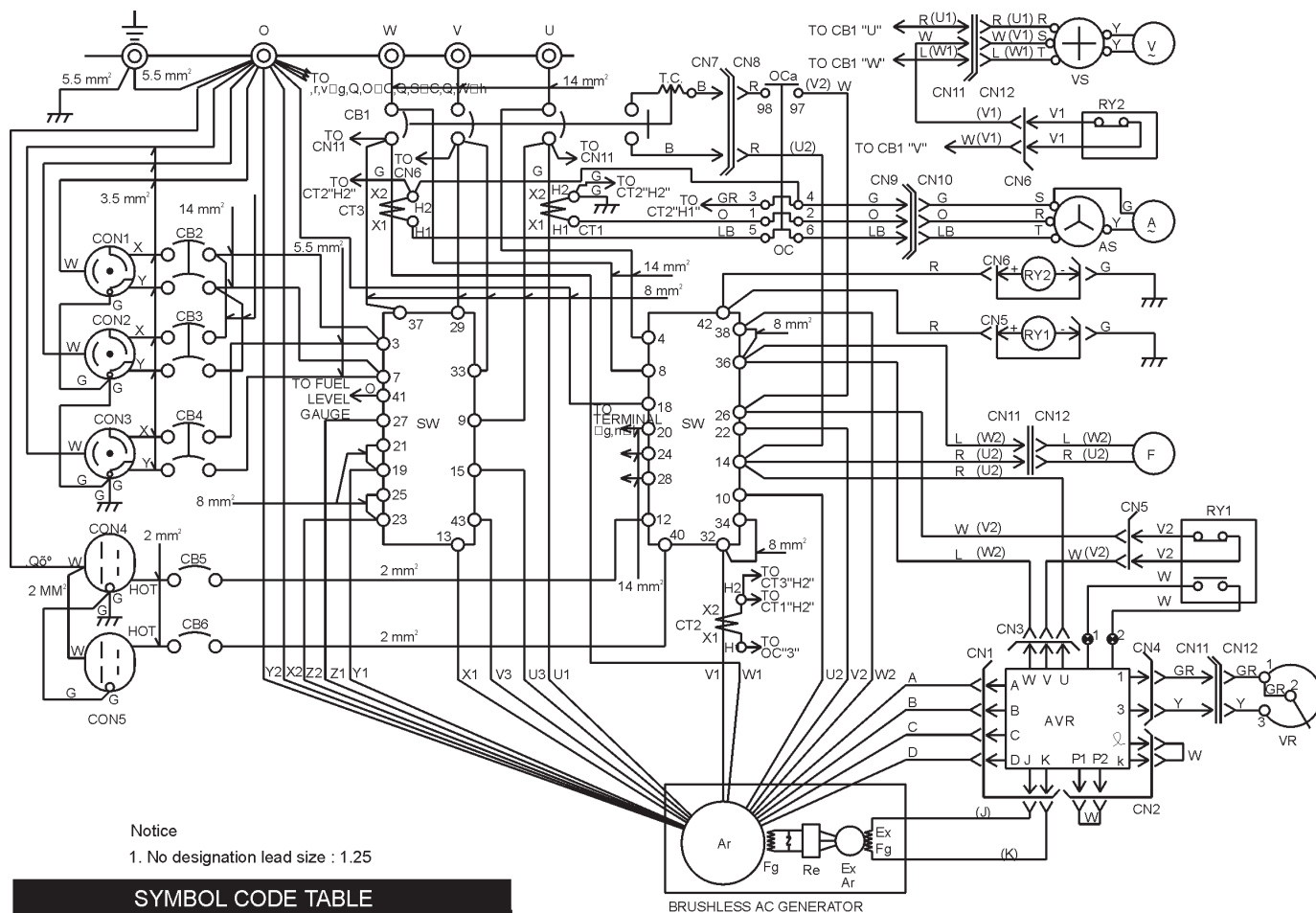

Figure 69. Engine Wiring Diagram(Continued)

DCA-45SSIU2 — GENERATOR WIRING DIAGRAM



Notice

1. No designation lead size : 1.25

SYMBOL CODE TABLE

SYMBOL	DESIGNATION
Ar	MAIN GENERATOR ARMATURE WINDING
Fg	MAIN GENERATOR FIELD WINDING
ExAr	EXCITER ARMATURE WINDING
ExFg	EXCITER FIELD WINDING
Re	RECTIFIER
AVR	AUTOMATIC VOLTAGE REGULATOR
VR	VOLTAGE REGULATOR (RHEOSTAT)
CT 1,2,3	CURRENT TRANSFORMER
AS	CHANGE-OVER SWITCH, AMMETER
A	AC AMMETER
VS	CHANGE-OVER SWITCH, VOLTMETER
V	AC VOLTMETER
F	FREQUENCY METER
Cb1	CIRCUIT BREAKER
CB 2,3,4	CIRCUIT BREAKER
CB 5,6	CIRCUIT BREAKER
CON 1,2,3	RECEPTACLE
CON 4,5	RECEPTACLE
OC	OVER CURRENT RELAY
SW	SELECTOR SWITCH
RY1,2	RELAY UNIT

COLOR CODE TABLE

CODE/ WIRE COLOR			
B	BLACK	R	RED
L	BLUE	W	WHITE
BR	BROWN	Y	YELLOW
G	GREEN	LB	LIGHT BLUE
GR	GRAY	LG	LIGHT GREEN
V	VIOLET	O	ORANGE
P	PINK		

Figure 70. Generator Wiring Diagram

CONNECTER ARRANGEMENT

(WIRING VIEW)

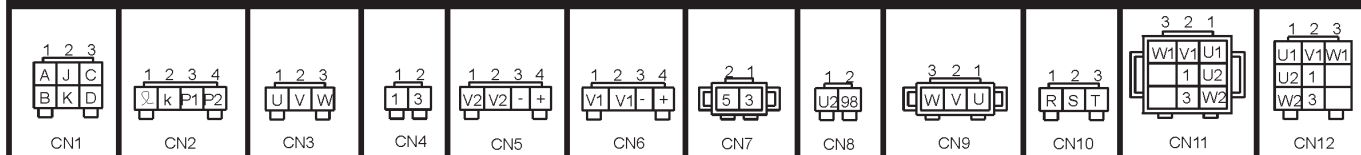

DCA-45SSIU2 — TROUBLESHOOTING (ENGINE)

Practically all breakdowns can be prevented by proper handling and maintenance inspections, but in the event of a breakdown, use the tables shown for

diagnosis based on the Engine Troubleshooting (Table 19). If the problem cannot be remedied, consult our company's business office or service plant.

TABLE 19. ENGINE TROUBLESHOOTING

SYMPTOM	POSSIBLE PROBLEM	SOLUTION
Engine does not start.	No fuel?	Replenish fuel.
	Air in the fuel system?	Bleed system.
	Water in the fuel system?	Remove water from fuel tank.
	Fuel pipe clogged?	Clean fuel pipe.
	Fuel filter clogged?	Clean or change fuel filter.
	Excessively high viscosity of fuel or engine oil at low temperature?	Use the specified fuel or engine oil.
	Fuel with low cetane number?	Use the specified fuel.
	Fuel leak due to loose injection pipe retaining nut?	Tighten nut.
	Incorrect injection timing?	Adjust.
	Fuel cam shaft worn?	Replace.
	Injection nozzle clogged?	Clean injection nozzle.
	Injection pump malfunctioning?	Repair or replace.
	Seizure of crankshaft, camshaft, piston, cylinder liner or bearing?	Repair or replace.
	Compression leak from cylinder?	Replace head gasket, tighten cylinder head bolt, glow plug and nozzle holder.
	Improper valve timing?	Correct or replace timing gear.
	Piston ring and liner worn?	Replace.
Excessive valve clearance?	Adjust.	
Starter does not run.	Starter malfunctioning?	Repair or replace.
	Wiring disconnected?	Connect wiring.

DCA-45SSIU2 — TROUBLESHOOTING (ENGINE)

TABLE 19. ENGINE TROUBLESHOOTING (CONTINUED)

SYMPTOM	POSSIBLE PROBLEM	SOLUTION
Engine revolution is not smooth.	Fuel filter clogged or dirty?	Clean or change.
	Air cleaner clogged?	Clean or change.
	Fuel leak due to loose injection pipe retaining nut?	Tighten nut.
	Injection pump malfunctioning?	Repair or replace.
	Incorrect nozzle opening pressure?	Adjust.
	Injection nozzle stuck or clogged?	Repair or replace.
	Fuel over flow pipe clogged?	Clean.
	Governor malfunctioning?	Repair.
Either white or blue exhaust gas is observed.	Excessive engine oil?	Reduce to the specified level.
	Piston ring and liner worn or stuck?	Repair or replace.
	Incorrect injection timing?	Adjust.
	Deficient compression?	Adjust top clearance.
Either black or dark gray exhaust gas is observed.	Overload?	Lessen the load.
	Low grade fuel used?	Use the specified fuel.
	Fuel filter clogged?	Clean or change.
	Air cleaner clogged?	Clean or change.
	Deficient nozzle injection?	Repair or replace the nozzle.
Deficient output.	Incorrect injection timing?	Adjust.
	Engine's moving parts seem to be seizing?	Repair or replace.
	Uneven fuel injection?	Repair or replace the injection pump.
	Deficient nozzle injection?	Repair or replace the nozzle.
	Compression leak?	Replace head gasket, tighten cylinder head bolt, glow plug and nozzle holder.

DCA-45SSIU2 — TROUBLESHOOTING (GENERATOR)

Practically all breakdowns can be prevented by proper handling and maintenance inspections, but in the event of a breakdown, use the tables shown for diagnosis based on the Engine and Radiator Troubleshooting (Table 20) . If the problem cannot be remedied, consult our company's business office or service plant.

TABLE 20. GENERATOR TROUBLESHOOTING

SYMPTOM	POSSIBLE PROBLEM	SOLUTION
No Voltage Output	AC Voltmeter defective?	Check output voltage using a voltmeter.
	Is wiring connection loose?	Check wiring and repair.
	Is AVR defective?	Replace if necessary.
	Defective Rotating Rectifier?	Check and replace.
Low Voltage Output	Is engine speed correct?	Turn engine throttle lever to "High".
	Is wiring connections loose?	Check wiring and repair.
	Defective AVR?	Replace if necessary.
High Voltage Output	Is wiring connections loose?	Check wiring and repair.
	Defective AVR?	Replace if necessary.
Circuit Breaker Tripped	Short Circuit in load?	Check load and repair.
	Over current?	Confirm load requirements and reduce.
	Defective circuit breaker?	Check and replace.
	Over current Relay actuated?	Confirm load requirement and replace.

EXPLANATION OF CODE IN REMARKS COLUMN

How to read the marks and remarks used in this parts book.

Items Found In the “Remarks” Column

Serial Numbers-Where indicated, this indicates a serial number range (inclusive) where a particular part is used.

Model Number-Where indicated, this shows that the corresponding part is utilized only with this specific model number or model number variant.

Items Found In the “Items Number” Column

All parts with same symbol in the number column, *, #, +, %, or <, belong to the same assembly or kit

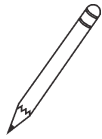
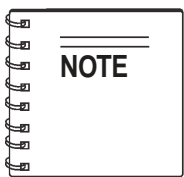

If more than one of the same reference number is listed, the last one listed indicates newest (or latest) part available.

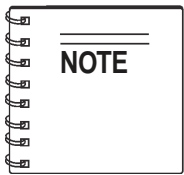

The contents of this catalog are subject to change without notice.

DCA-45SSIU2W/ISUZU 4BG1 DIESEL ENGINE 1 TO 3 UNITS

<u>Qty.</u>	<u>P/N</u>	<u>Description</u>
1	0601820671	AUTOMATIC VOLTAGE REGULATOR
1	0601840073	RHEOSTAT VOLTAGE REGULATOR
1	0601840121	KNOB RHEOSTAT
1	M1310500403	RADIATOR HOSE
1	M1310500303	RADIATOR HOSE
5	8943212191	OIL FILTER
5	X132400240	FUEL FILTER
5	0602046368	AIR ELEMENT
3	0602042420	FUEL TANK, IN-LINE FILTER
1	0602122272	UNIT, OIL PRESSURE
1	0602123260	UNIT WATER TEMPERATURE
2	0601810245	BULB, ALARM LAMP
1	8970208220	FAN BELT
1	1823100080	STARTER SWITCH
3	KEYISUZUF	KEY, STARTER SWITCH
2	0601808803	CIRCUIT BREAKER, GF-530EM 125V 20A
3	0601808804	CIRCUIT BREAKER, CS6369 250V 50A
4	9825139289	GLOW PLUG
1	47130106	KNOB, SELECTOR SWITCH
1	5825500422	EMERGENCY RELAY
1	0605505070	FUEL CAP

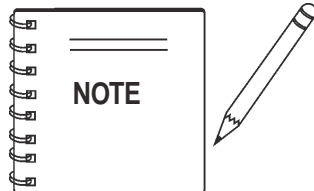

Part number on this Suggested Spare Parts list may supercede/replace the P/N shown in the text pages of this book.

DCA-45SSIU2 — GENERATOR ASSY.

GENERATOR ASSY.

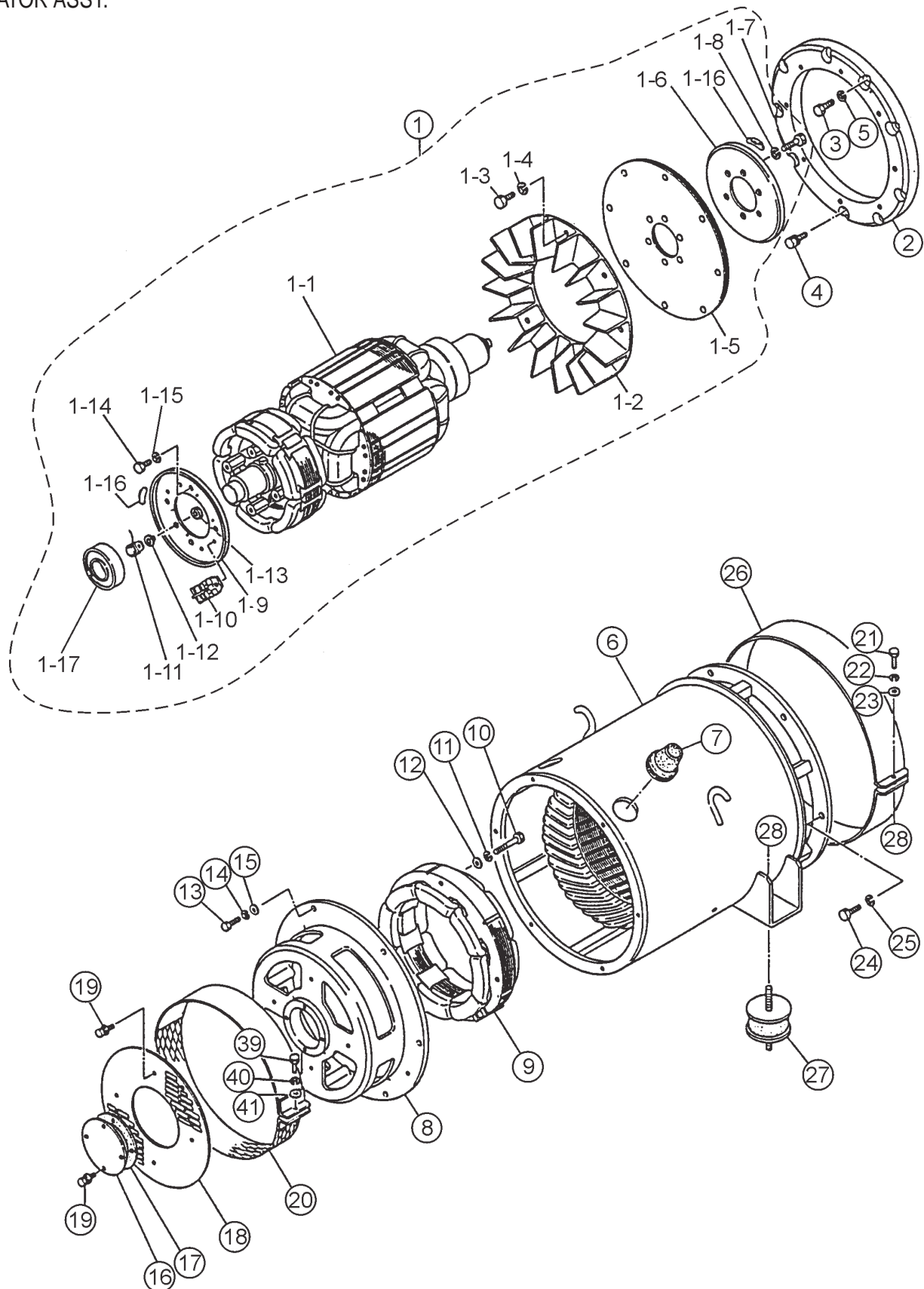

DCA-45SSIU2 — GENERATOR ASSY.

GENERATOR ASSY.

<u>NO.</u>	<u>PART NO.</u>	<u>ITEM</u>	<u>QTY.</u>	<u>REMARKS</u>
1	8051000042	ROTOR ASSY.	1	INCLUDES ITEMS W/*
1-1*		FIELD ASSY.	1	
1-2*	8051070003	FAN	1	
1-3*	0012110035	HEX. HEAD BOLT	8	
1-4*	030210250	LOCK WASHER	8	REPLACES 0042510000
1-5*	8041611004	COUPLING DISK	4	
1-6*	8041015003	BALANCING PLATE	1	
1-7*	0105091025	HEX. HEAD BOLT	6	REPLACES 0010310025
1-8*	0042510000	LOCK WASHER	6	
1-9*	8001026013	SET PLATE, RECTIFIER	1	
1-10*	0601821349	RECTIFIER	2	PT 3610
1-11*	0601822601	SURGE ABSORBER	1	ERZ-M14JK621A
1-12*	8001020004	INSULATOR WASHER	1	
1-13*	8001020504	INSULATOR WASHER	1	
1-14*	011008020	HEX. HEAD BOLT	4	REPLACES 0010108020
1-15*	0040080000	LOCK WASHER	4	
1-16*	0601000209	BALANCING WEIGHT KIT	1	
1-17*	0071906310	BEARING	1	6310 DDU C3
2	8051614003	COUPLING RING	1	REPLACES M1163400203
3	0801831704A	REAMER BOLT	2	REPLACES M9200100204
4	0012810030	HEX. HEAD BOLT	7	
5	030210250	LOCK WASHER	2	REPLACES 0042510000
6	8051340503	STRATOR ASSY.	1	
7	0845041904	GROMMET	2	
8	8041315202	END BRACKET	1	
9	8041350013	FIELD ASSY. EXCITER	1	
10	0010308065	HEX. HEAD BOLT	4	
11	0042608000	LOCK WASHER	4	
12	031108160	PLAIN WASHER	4	REPLACES 0041208000
13	0010108030	HEX. HEAD BOLT	6	
14	0040008000	LOCK WASHER	6	
15	031108160	PLAIN WASHER	6	REPLACES 0041208000
16	8041310024	COVER, BEARING	1	
17	8041312014	GASKET, BEARING	1	
18	8041331014	COVER, END BRACKET	1	
19	0017106012	HEX. HEAD BOLT	8	REPLACES 0017106012
20	8001333003	COVER, END BRACKET	1	
21	0010106030	HEX. HEAD BOLT	2	
22	0040006000	LOCK WASHER	2	
23	952404470	PLAIN WASHER	2	REPLACES 0041206000
24	0105091025	HEX. HEAD BOLT	6	REPLACES 0010310025
25	0042510000	LOCK WASHER	6	
26	8051332014	COVER, FAN	1	
27	0605000010	RUBBER SUSPENSION	2	
28	0030012000	HEX. NUT	2	
28	0040012000	LOCK WASHER	2	
28	031112230	PLAIN WASHER	2	REPLACES 0041212000

DCA-45SSIU2 — CONTROL BOX ASSY.

CONTROL BOX ASSY.

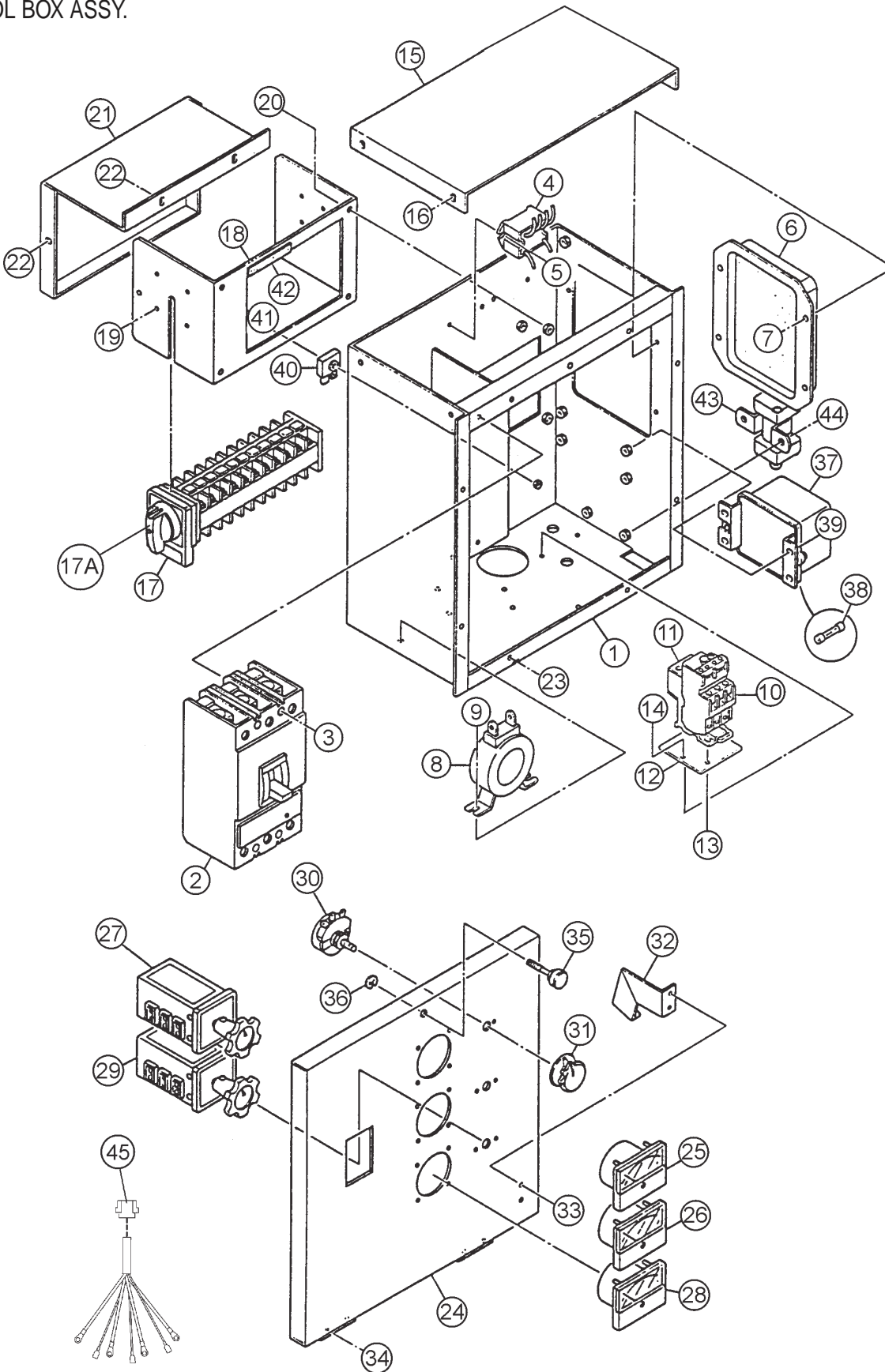

DCA-45SSIU2 — CONTROL BOX ASSY.

CONTROL BOX ASSY.

<u>NO.</u>	<u>PART NO.</u>	<u>ITEM</u>	<u>QTY.</u>	<u>REMARKS</u>
1	M1213000402	CONTROL BOX	1	S/N7500646 TO 7200915
1	M1213000412	CONTROL BOX	1	S/N7200916 TO 7200995
1	M1213000422	CONTROL BOX	1	S/N7200996~
2	0601808811	CIRCUIT BREAKER, KAF3611010213P110A	1	
3	0027105080	MACHINE SCREW	4	
4	0601823863	RELAY UNIT	2	MSA9013A
5	0021304015	MACHINE SCREW	4	REPLACES 0027104015
6	0601820671	AUTOMATIC VOLTAGE REGULATOR	1	NTA-5A-2DB
7	0027105010	MACHINE SCREW	4	S/N7200646 TO 7201105
7	0027105015	MACHINE SCREW	4	S/N7201106~
8	0601806116	CURRENT TRANSFORMER	3	812-943 75/5A
9	011808015	MACHINE SCREW	6	REPLACES 0027106015
10	0601820845	OVER CURRENT RELAY	1	LR2D1308
11	0601820846	OVER CURRENT RELAY	1	LR7D1064
12	M1260600004	FITTING BRACKET	1	S/N7200646 TO 7200996
13	0021304015	MACHINE SCREW	2	REPLACES 0027104015
13	0030004000	HEX. NUT	2	REPLACES 0207004000
14	0021004010	MACHINE SCREW	2	S/N7200646 TO 7200996
15	M1213500303	CONTROL BOX COVER	1	
16	011106015	HEX. HEAD BOLT	4	REPLACES 0016906015
17	M1923100004	SELECTOR SWITCH	1	VY-40
17A	47130106	KNOB, SELECTOR SWITCH	1	
18	M1213600104	SWITCH BRACKET	1	S/N7200646 TO 7200915
18	M1213600114	SWITCH BRACKET	1	S/N7200916~
19	0027103010	MACHINE SCREW	4	
20	011106015	HEX. HEAD BOLT	4	REPLACES 0016906015
21	M1213600004	SWITCH COVER	1	S/N7200646 TO 7200915
21	M1213600014	SWITCH COVER	1	S/N7200916~
22	011106015	HEX. HEAD BOLT	4	S/N7200646 TO 7200870;
			REPLACES 0016906015
22	011106015	HEX. HEAD BOLT	3	S/N720871~; REPLACES
			0016906015
23	011106015	HEX. HEAD BOLT	8	REPLACES 0016906015
23	0040506000	TOOTHED WASHER	1	
24	M1223000303	CONTROL PANEL	1	
25	0601807630	FREQUENCY METER, 264250JDJ9	1	S/N7200646 TO 7202360
25	0601807641	FREQUENCY METER, FCF6 45-65Hz 240V ...	1	S/N7202361~

DCA-45SSIU2 — CONTROL BOX ASSY. (CONT.)

CONTROL BOX ASSY. (CONT.)

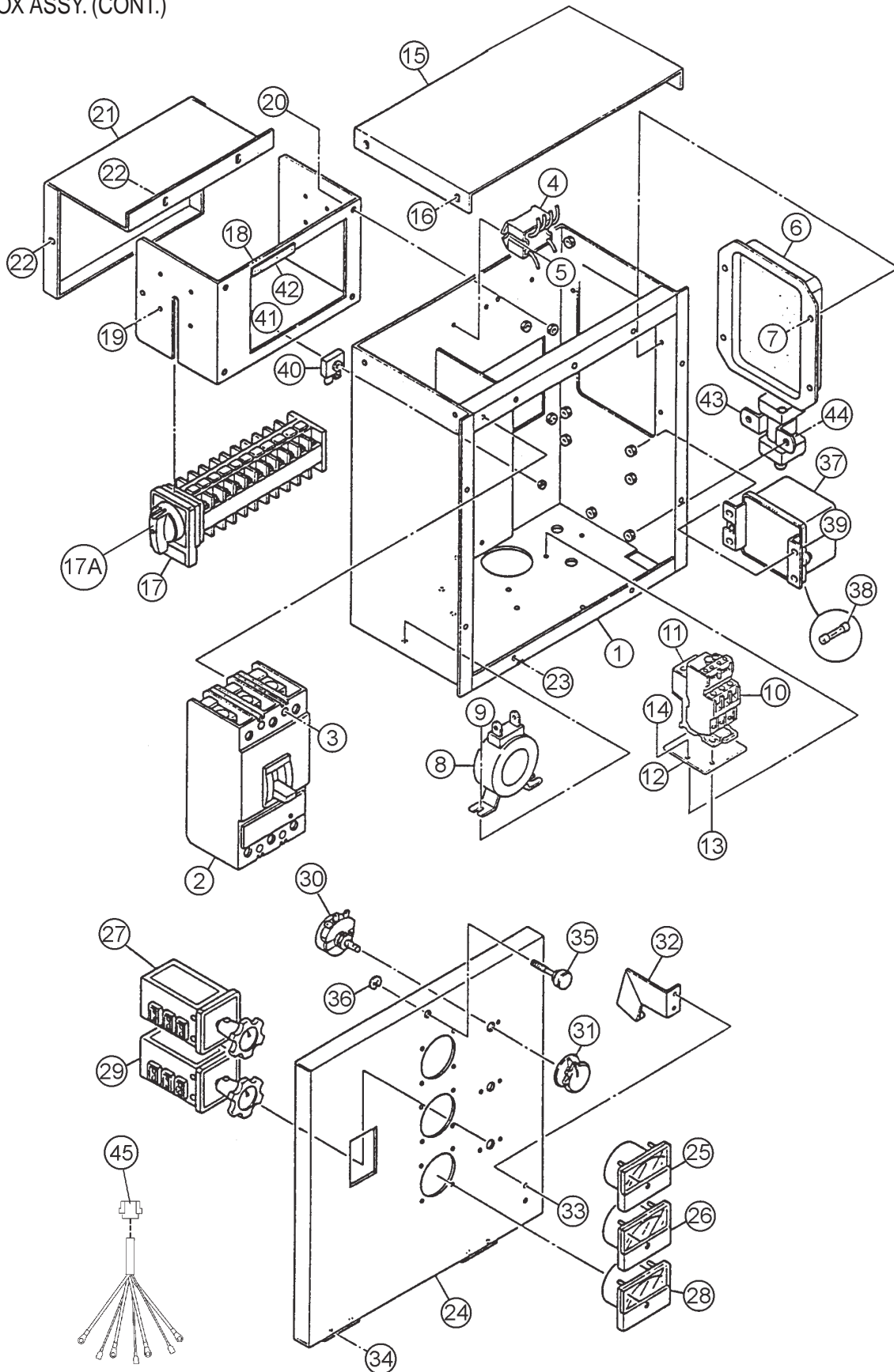

DCA-45SSIU2 — CONTROL BOX ASSY. (CONT.)

CONTROL BOX ASSY. (CONT.)

<u>NO.</u>	<u>PART NO.</u>	<u>ITEM</u>	<u>QTY.</u>	<u>REMARKS</u>
26	0601808950	AC AMMETER, 260240LSPB1	1	S/N7200646 TO 7202360
26	0601808986	AC AMMETER, ACF60-75A,0-150A/5A ...	1	S/N7202361~
27	0601801040	CHANGE-OVER SWITCH, AMMETER	1	SL-2AS
28	0601806813	AC VOLTMETER, 260244SJSJ1	1	S/N7200646 TO S/N7202360
28	0601806859	AC VOLTMETER, SCF6 0-600V	1	S/N7202361~
29	0601801041	CHANGE-OVER SWITCH, VOLTMETER	1	SL-2VS
30	0601840073	RHEOSTAT (VOLTAGE REGULATOR)	1	RA20A2SE102BJ 2W 1kOHM
31	0601840121	KNOB	1	
32	M1223100004	STOPPER	1	
33	0027105015	MACHINE SCREW	2	S/N7200646 TO 7201195
33	0027105010	MACHINE SCREW	2	S/N7201196~
34	0027105015	MACHINE SCREW	4	S/N7200646 TO 7201195
34	0027105010	MACHINE SCREW	4	S/N7201196~
35	M9220100004	SET SCREW	1	
36	0080200007	SNAP RING	1	
37	5825500422	EMERGENCY RELAY - 12 VOLT	1	REPLACES 0602200409
37	1825500732	EMERGENCY RELAY - 24 VOLT	1	
38	0601802132	FUSE, 10A	1	
39	011106015	HEX. HEAD BOLT	4	REPLACES 0016906015
40	0601821370	RECTIFIER	2	REPLACES 0601823240
41	0021004040	MACHINE SCREW	1	
41	0040004000	LOCK WASHER	1	
41	031104080	PLAIN WASHER	1	REPLACES 0041204000
42	0330000530	EDGING	1	
43	1825530400	SAFETY RELAY	1	REPLACES 0602200304
44	011106015	HEX. HEAD BOLT	2	REPLACES 0016906015
45	M12467001004	WIRE HARNESS, GENERATOR	1	UP TO S/N7106114
45	M1246700524	WIRE HARNESS, GENERATOR	1	S/N7106115~

DCA-45SSIU2 — ENGINE AND RADIATOR ASSY.

ENGINE AND RADIATOR ASSY.

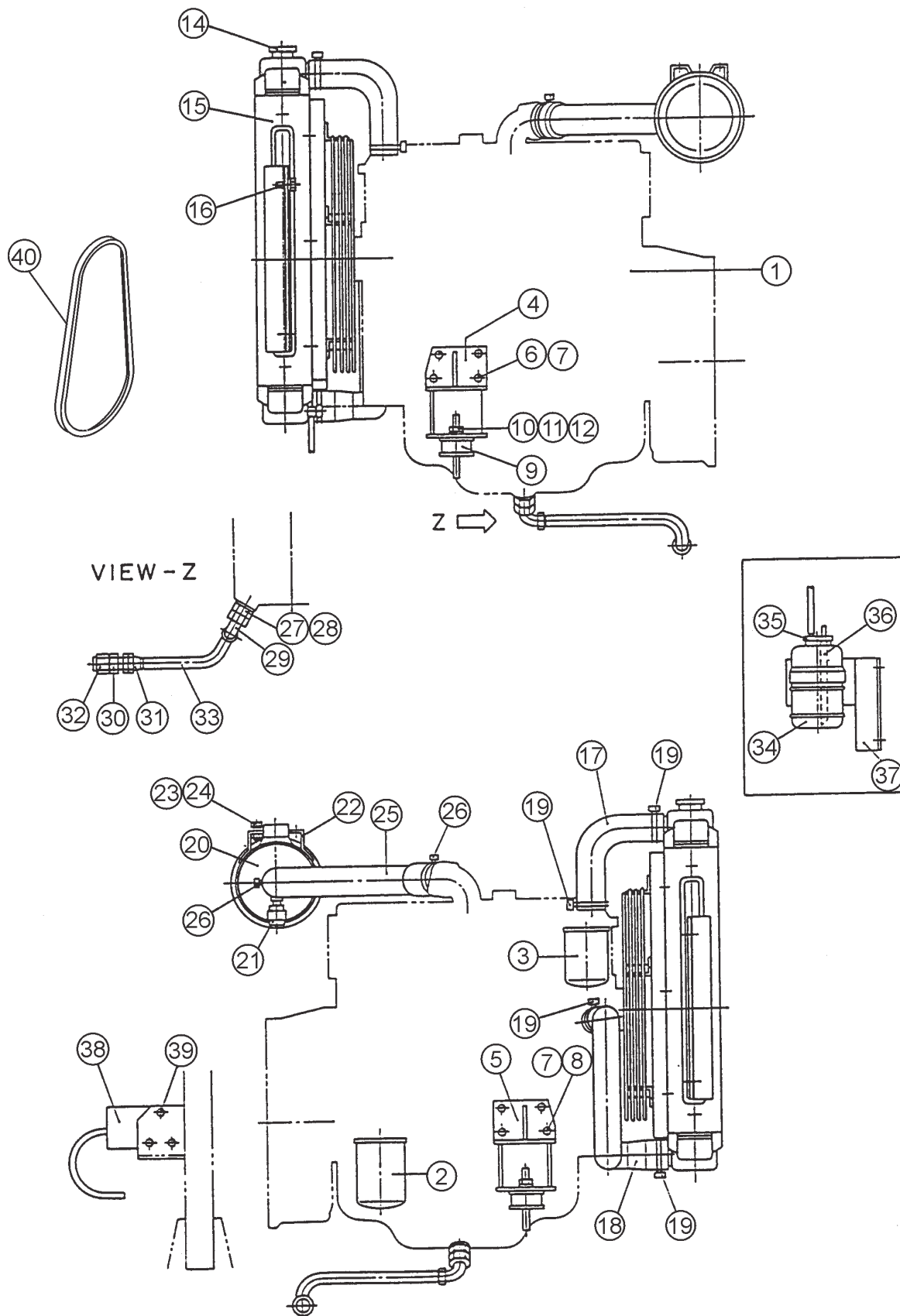

DCA-45SSIU2 — ENGINE AND RADIATOR ASSY.

ENGINE AND RADIATOR ASSY.

<u>NO.</u>	<u>PART NO.</u>	<u>ITEM</u>	<u>QTY.</u>	<u>REMARKS</u>
1	M19232000034	ENGINE	1	ISUZU B-4BG1
2	8943212191	CARTRIDGE, OIL FILTER	1	REPLACES 06020412113
3	X132400240	CARTRIDGE, FUEL FILTER	1	REPLACES 1132400791 AND 0602042511
4	M1303200103	ENGINE FOOT	1	
5	M1303200203	ENGINE FOOT	1	
6	0105091025	HEX. HEAD BOLT	7	REPLACES 0010710025
7	004251000	LOCK WASHER	8	
8	003041000	HEX. NUT	1	
9	060500008	RUBBER SUSPENSION	2	
10	00300120000	HEX. NUT	2	
11	0040012000	LOCK WASHER	2	
12	031112230	PLAIN WASHER	2	REPLACES 0041212000
13	0602012740	RADIATOR, C2810050000R2	1	S/N7200646 TO 7200705
13	0602012741	RADIATOR, C2810050001	1	S/N7200706~
14	0602011065	CAP, RADIATOR	1	C89C0115010
15	011008020	HEX. HEAD BOLT	6	REPLACES 0016908020
16	M1310500403	RADIATOR HOSE, UPPER	1	
17	M1310500303	RADIATOR HOSE, LOWER	1	
18	0605515147	HOSE BAND	4	
19	0602046232	AIR CLEANER	1	FWG065295
20	0602046368	ELEMENT. AIR CLEANER	1	P181052
21	0602040650	INDICATOR, AIR CLEANER	1	RBX002252
22	0602040595	BAND AIR CLEANER	2	P007191
23	011008020	HEX. HEAD BOLT	4	REPLACES 0016908020
24	020108060	HEX. NUT	4	REPLACES 0207008000
25	M1373100203	HOSE, AIR CLEANER	1	
26	060551548	HOSE BAND	2	
27	0602022560	ADAPTER	1	
28	M1320300304	PACKING, OIL PAN SIDE	1	
29	0602022561	90° ELBOW	1	
30	0602022562	UNION	1	
31	0602022792	SWIVEL	1	
32	0602021070	CAP	1	
33	0602021572	DRAIN HOSE	1	
34	M9300000103	RESERVE TANK	1	
35	M9300100003	CAP, RESERVE TANK	1	
36	0199100175	HOSE	1	
37	M1316100404	BRACKET, RESERVE TANK	1	
38	1819001902	ENGINE STOPPER	1	REPLACES 0602210810
38	0601802133	FUSE, 5A	1	
39	011808015	MACHINE SCREW	3	REPLACES 0027106015
40	8970208220	FAN BELT	1	REPLACES 5136711320 AND 0602011403

DCA-45SSIU2 — ENGINE OPERATING PANEL ASSY.

ENGINE OPERATING PANEL ASSY.

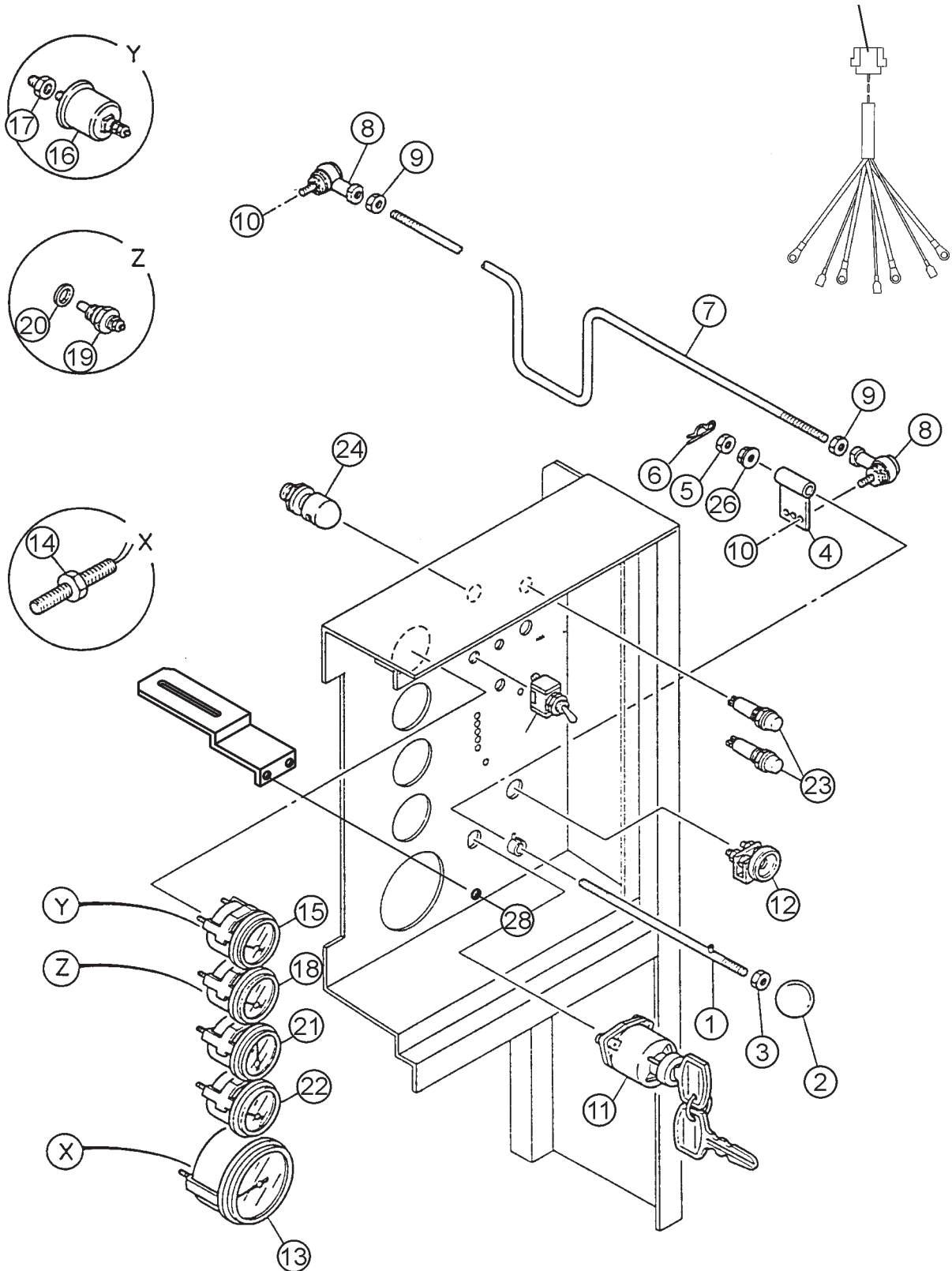

DCA-45SSIU2 — ENGINE OPERATING PANEL ASSY.

ENGINE OPERATING PANEL ASSY.

<u>NO.</u>	<u>PART NO.</u>	<u>ITEM</u>	<u>QTY.</u>	<u>REMARKS</u>
1	M1354300304	SLIDE LEVER	1	
2	0601840190	KNOB	1	REPLACES M9320000004
3	020108060	HEX. NUT	1	REPLACES 0036003000
4	M1354200004	BRACKET	1	
5	020108060	HEX. NUT	1	REPLACES 0030008000
6	06054010550	SNAP PIN	1	
7	M1354300104	GOVERNOR ROD	1	
8	0602180106	BALL JOINT	1	
9	020108060	HEX. NUT	2	REPLACES 0030008000
10	0207006000	HEX. NUT	2	
10	0041206000	PLAIN WASHER	2	
11	1823100080	STARTER SWITCH	1	REPLACES 0602100004
11	KEYISUZUF	KEY, STARTER SWITCH	1	
12	8944626110	PREHEAT LAMP	1	REPLACES 9825300410 AND 0602102066
13	0602120095	TACHOMETER	1	103680
14	0602120480	PICKUP, TACHOMETER	1	7154400
15	0602122093	OIL PRESSURE GAUGE	1	100174
16	0602122272	UNIT, OIL PRESSURE	1	REPLACES 0602122271
17	M9200100004	ADAPTER	1	
18	0602123090	WATER TEMPERATURE GAUGE ...	1	100683
19	0602123260	UNIT, WATER TEMPERATURE	1	0209400
20	9075720140	PACKING	1	REPLACES 9095720140 AND 0602121109
21	0602121080	CHARGING AMMETER	1	100158
22	0602125090	FUEL GAUGE	1	100176
23	0602103092	ALARM LAMP	2	PL-05
23	0601810245	BULB	2	E-10 T-10 DC18V
23	0601823223	RECTIFIER	2	30D4
24	0601810141	PANEL LIGHT	1	9826800370
25	0601831330	SWITCH, PANEL LIGHT	1	900001
26	020108060	HEX. NUT	1	REPLACES 0207008000
27	M1354200204	GUIDE, SLIDE LEVER	1	S/N7200646 TO 7200675
28	0027105015	MACHINE SCREW	2	S/N7200646 TO 7200675
29	M1357200302	WIRE HARNESS. ENGINE	1	

DCA-45SSIU2 — OUTPUT TERMINAL ASSY.

OUTPUT TERMINAL ASSY.

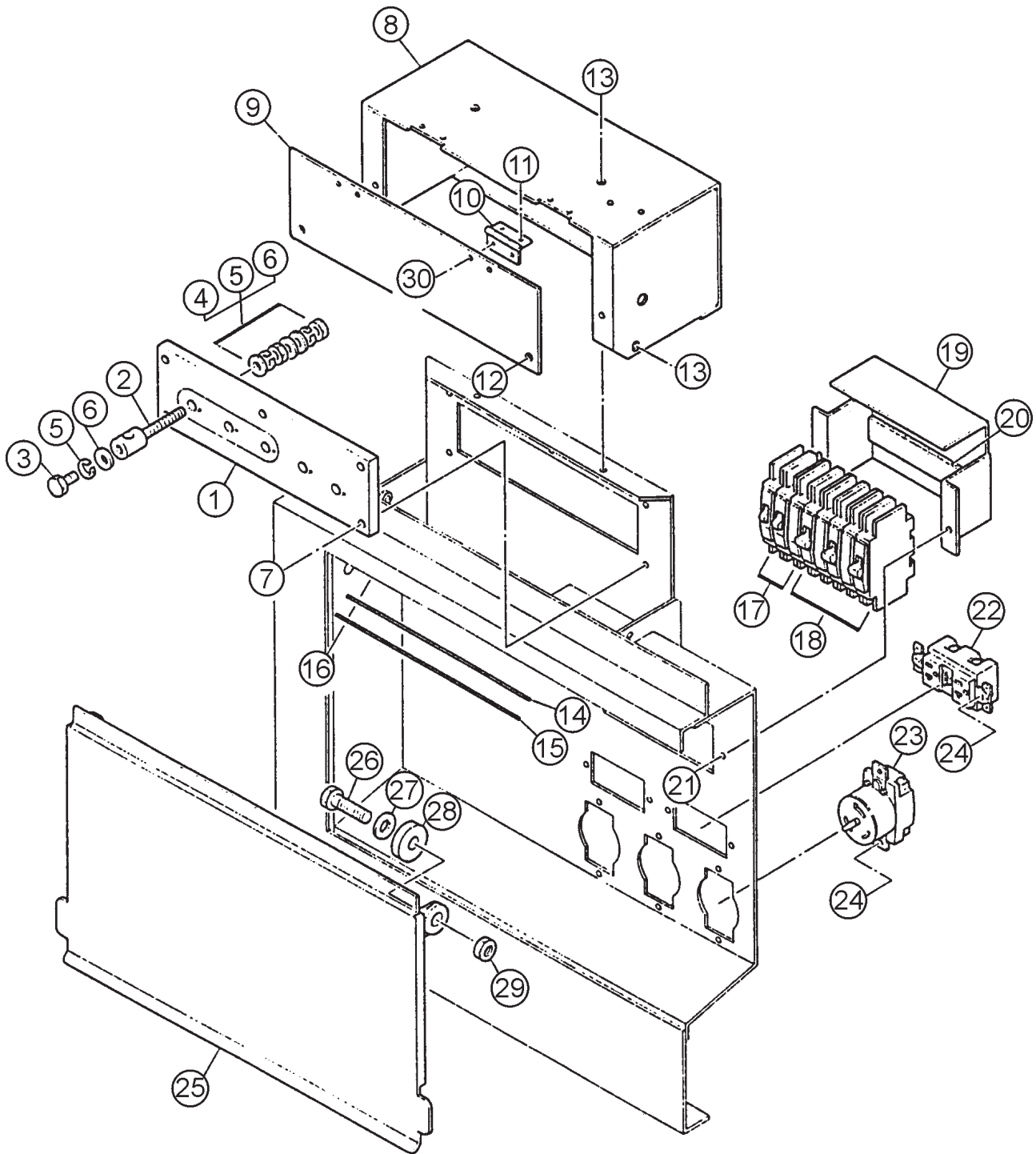

DCA-45SSIU2 — OUTPUT TERMINAL ASSY.

OUTPUT TERMINAL ASSY.

<u>NO.</u>	<u>PART NO.</u>	<u>ITEM</u>	<u>QTY</u>	<u>REMARKS</u>
1	8111860303	TERMINAL PANEL.....	1 REPLACES M1230700103
2	0801831704A	OUTPUT TERMINAL BOLT	5 REPLACES M9220100204
3	012210020	TIE BOLT	5 REPLACES M9220100104
4	0039310000	HEX. NUT	10	
5	0040010000	LOCK WASHER	15	
6	0041410000	PLAIN WASHER	20	
7	0016908025	HEX. HEAD BOLT	5	
8	M1236100603	TERMINAL COVER	1 S/N7200646 TO 7201195
8	M1236100613	TERMINAL COVER	1 S/N7201196~
9	M1236100704	OUTPUT WINDOW	1	
10	0605010040	HINGE	2	
11	0027103010	MACHINE SCREW	4	
11	0207003000	HEX. NUT	4 REPLACES 0030003000
11	58413	PLAIN WASHER	4 REPLACES 0041203000
12	016906020	HEX. HEAD BOLT	2	
13	011106015	HEX. HEAD BOLT	4 REPLACES 0016906015
14	M1236400004	CABLE OUTLET COVER	1	
15	M1236300004	SUPPORTER, CABLE OUTLET COVER	1	
16	011206020	HEX. HEAD BOLT	6 REPLACES 0016906020
17	0601808803	CIRCUIT BREAKER	2 QOU 120B 19 20A
18	0601808804	CIRCUIT BREAKER	3 QOU 250B 2P 50A
19	M1260700304	BREAKER FITTING COVER	1	
20	0222100150	CUSHION RUBBER	1	
21	011206020	HEX. HEAD BOLT	2 REPLACES 0016906020
22	0601812597	RECEPTACLE, GF-530EM 125V 20Ax2	2 REPLACES 0601812598
23	0601811034	RECEPTACLE, CS6369 250V 50A	3 REPLACES 0601812538
24	0021304015	MACHINE SCREW	10 REPLACES 0027104015
24	0030004000	HEX.NUT	10 REPLACES 0207004000
25	M1236100803	TERMINAL COVER	1	
26	012212045	HEX. HEAD BOLT	2 REPLACES 0010112045
27	031112230	PLAIN WASHER	2 REPLACES 0041212000
28	M9310200004	STAY RUBBER	2	
29	0030012000	HEX. NUT	2	
30	0027103010	MACHINE SCREW	4	
30	0207003000	HEX.NUT	4 REPLACES 0030003000

DCA-45SSIU2 — BATTERY ASSY.

BATTERY ASSY.

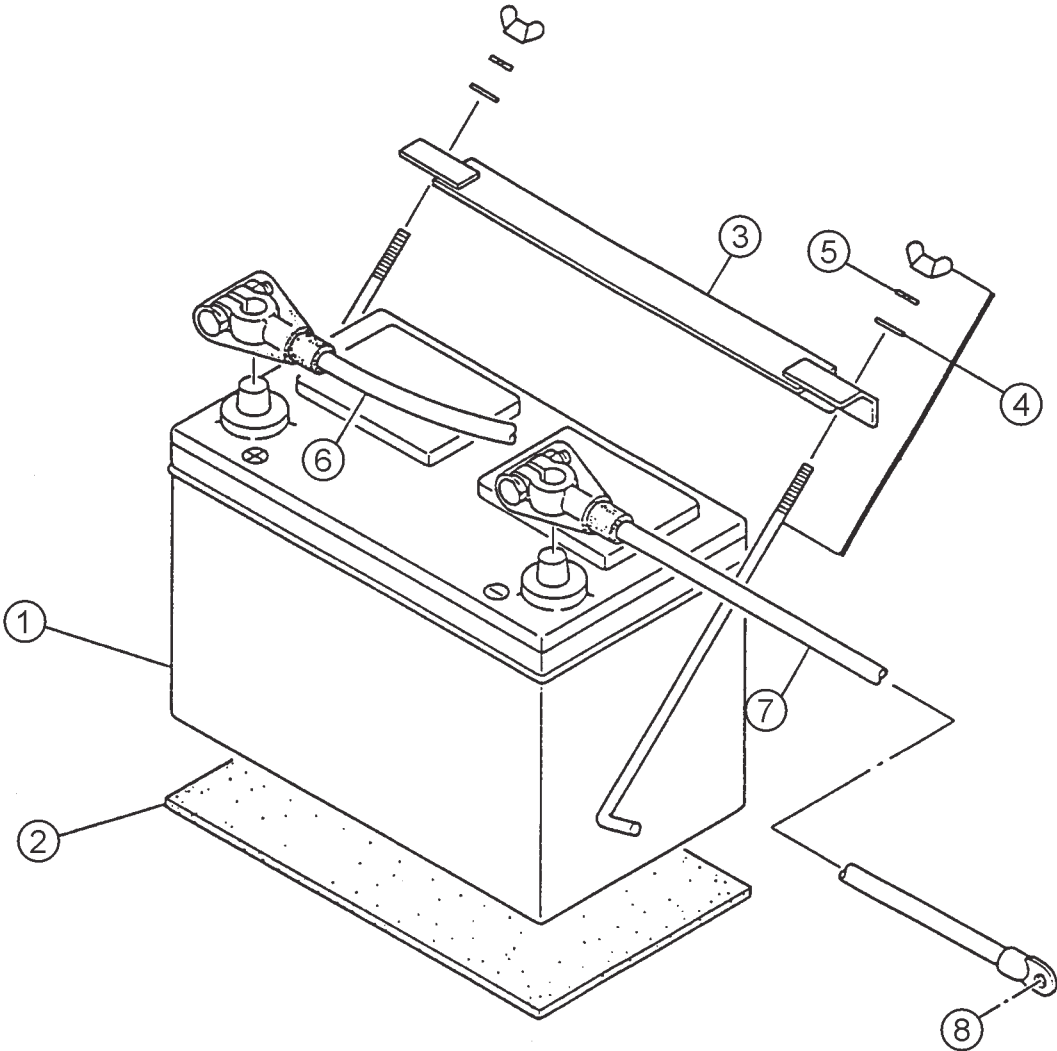

BATTERY ASSY.

<u>NO.</u>	<u>PART NO.</u>	<u>ITEM</u>	<u>QTY.</u>	<u>REMARKS</u>
1	551010280	BATTERY, 627MFD	1	REPLACES 0602220187
2	M9310500014	BATTERY SHEET	1	
3	M9103000304	BATTERY BAND	1	
4	0602220920	BATTERY BOLT SET	2	
5	0040006000	LOCK WASHER	2	
6	M1346400204	BATTERY CABLE	1	
7	M1346400404	BATTERY CABLE	1	
8	0016910020	HEX. HEAD BOLT	1	
8	0040510000	TOOTHED WASHER	1	

DCA-45SSIU2 — MUFFLER ASSY.

MUFFLER ASSY.

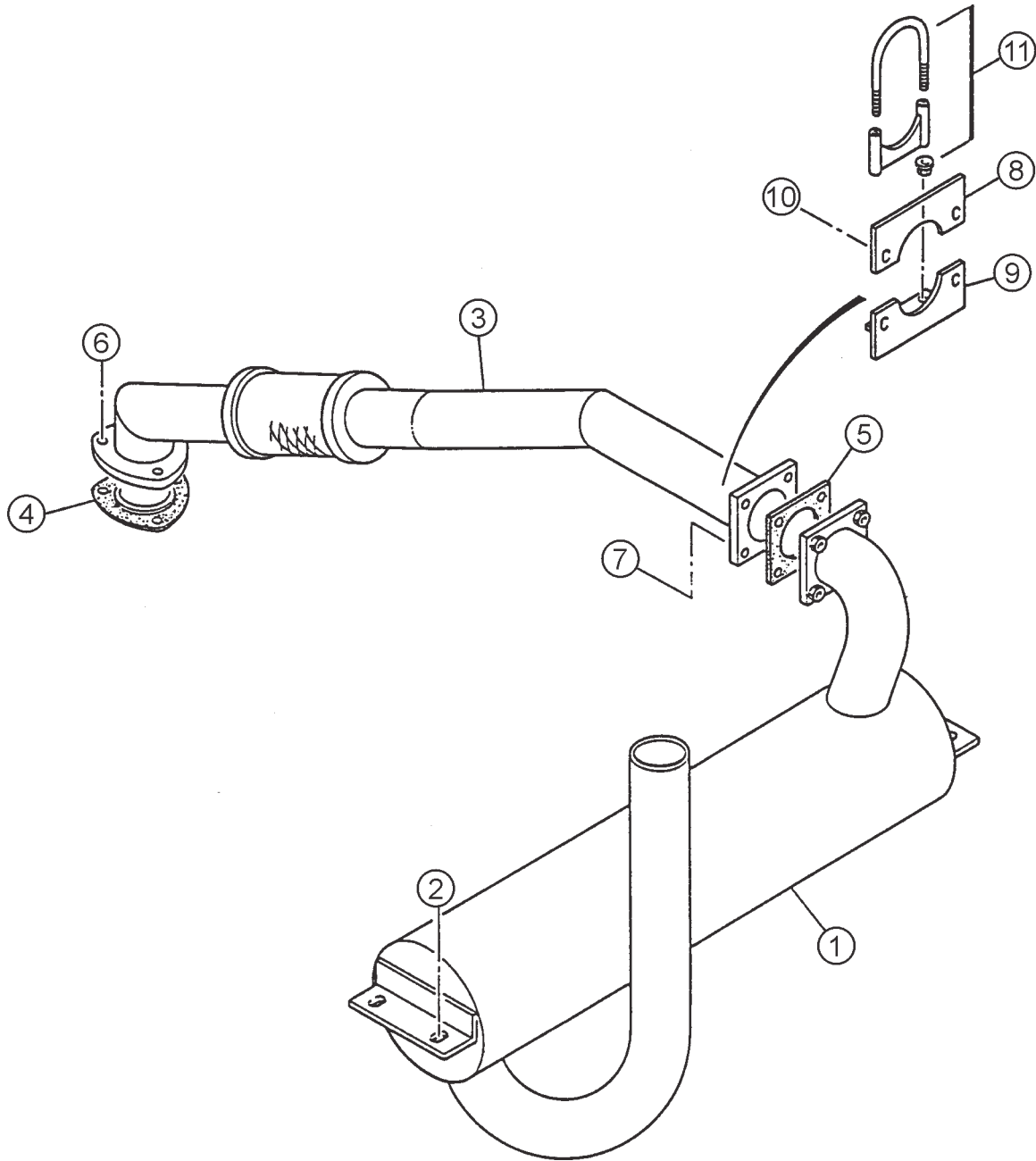

MUFFLER ASSY.

<u>NO.</u>	<u>PART NO.</u>	<u>ITEM</u>	<u>QTY.</u>	<u>REMARKS</u>
1	0602300165	MUFFLER	1	27242N
2	0016910025	HEX. HEAD BOLT	4	
3	M1333001303	EXHAUST PIPE	1	
4	1141450690	GASKET	1	REPLACES 0602320004
5	M1333200114	GASKET	1	
6	9098400850	HEX. NUT	3	REPLACES 0602323001
6	0040010000	LOCK WASHER	3	
7	0016908035	HEX. HEAD BOLT	4	
8	M1330400304	COVER	1	
9	M1333300004	BRACKET	1	
10	0016906015	HEX. HEAD BOLT	4	
11	0602326090	U BOLT SET	1	

DCA-45SSIU2 — FUEL TANK ASSY.

FUEL TANK ASSY.

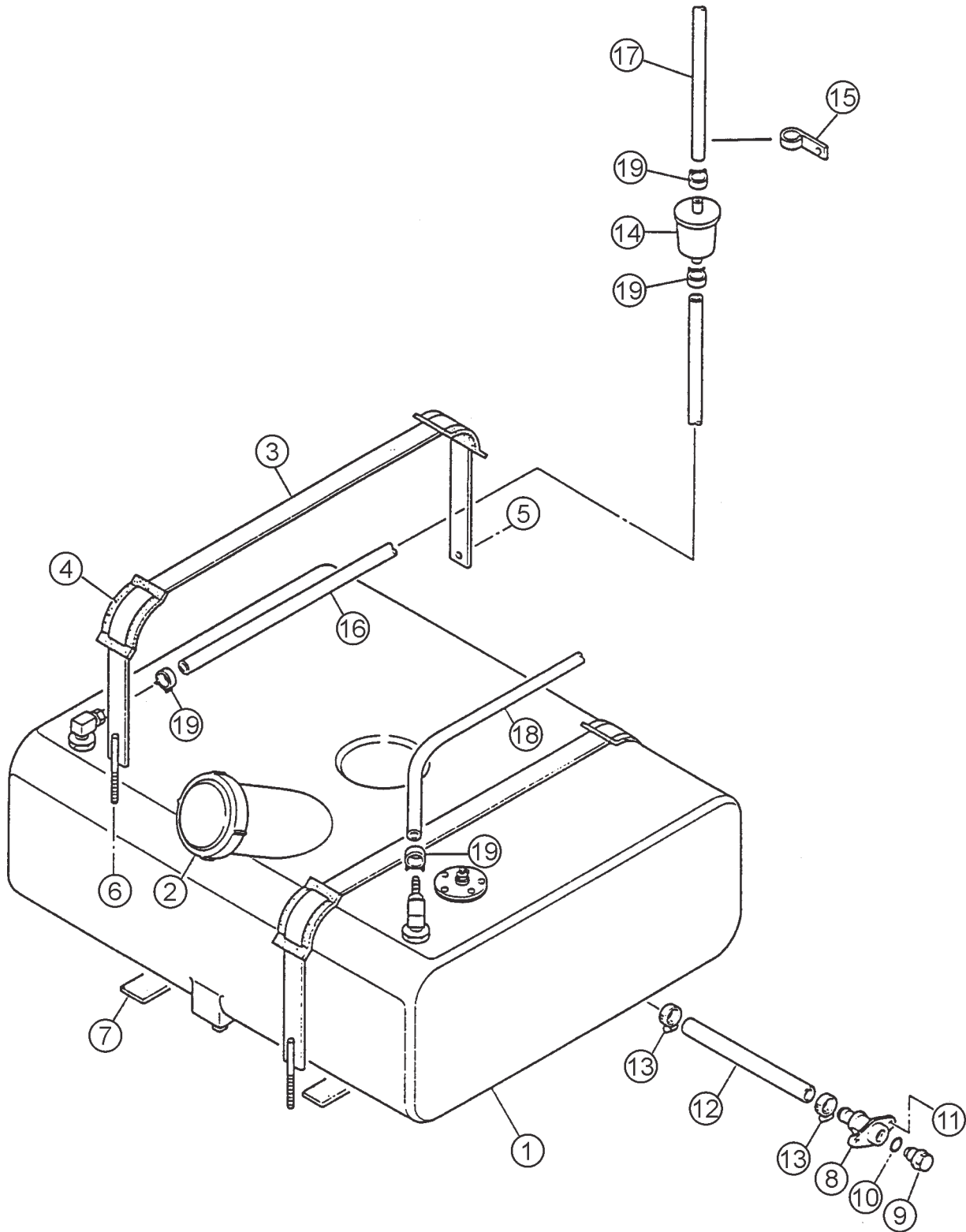

DCA-45SSIU2 — FUEL TANK ASSY.

FUEL TANK ASSY.

<u>NO.</u>	<u>PART NO.</u>	<u>ITEM</u>	<u>QTY.</u>	<u>REMARKS</u>
1	M1363000302	FUEL TANK	1	
2	0605505070	CAP, FUEL TANK	1	
3	M1363200104	TANK BAND	2	
4	M9310500104	SUPPORTER SHEET	4	
5	011008020	HEX. HEAD BOLT	2	REPLACES 0016908020
6	0207308000	HEX. NUT	2	
7	0222100600	RUBBER SHEET	2	
8	M9200000003	DRAIN JOINT	1	
9	M9200200004	DRAIN BOLT	1	
10	0150000018	O RING	1	
11	011206020	HEX. HEAD BOLT	2	REPLACES 0016906020
12	M1363400104	DRAIN HOSE	1	
13	0605515198	HOSE BAND	2	
14	0602042420	FUEL FILTER	1	
15	0602220911	CLAMP	1	
16	0191301200	SUCTION HOSE	1	
17	0191300300	SUCTION HOSE	1	
18	0191302000	RETURN HOSE	1	
19	0605515109	HOSE BAND	6	

DCA-45SSIU2 — ENCLOSURE ASSY.

ENCLOSURE ASSY.

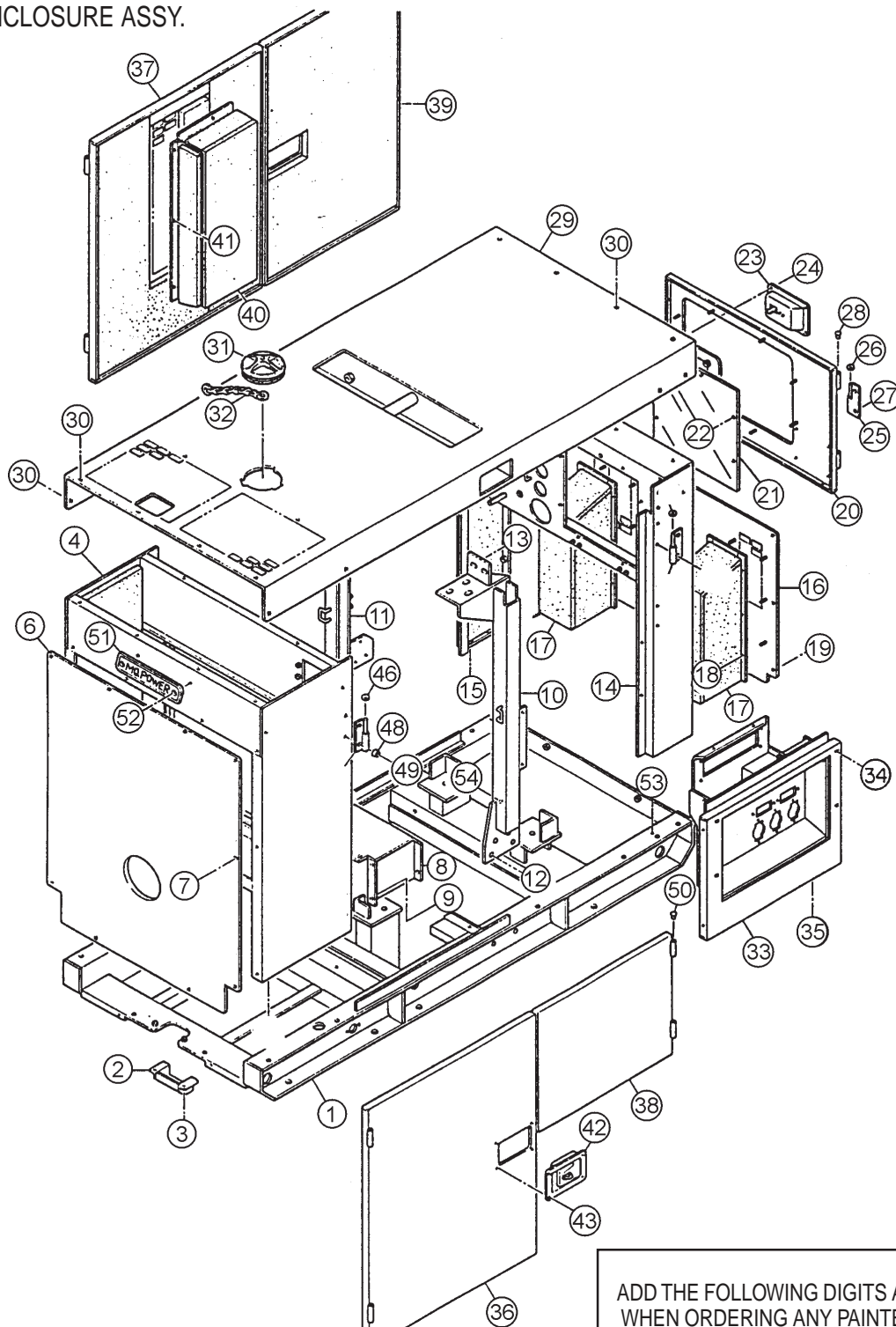

ADD THE FOLLOWING DIGITS AFTER THE PART NUMBER
WHEN ORDERING ANY PAINTED PANEL TO INDICATE
COLOR OF UNIT:

- | | |
|-----------------|----------------------|
| 1-ORANGE | 5-BLACK |
| 2-WHITE | 6-CATERPILLAR YELLOW |
| 3-SPECTRUM GRAY | 7-CATO GOLD |
| 4-SUNBELT GREEN | 8-RED |

THE SERIAL NUMBER MAY BE REQUIRED.

DCA-45SSIU2 — ENCLOSURE ASSY.

ENCLOSURE ASSY.

<u>NO.</u>	<u>PART NO.</u>	<u>ITEM</u>	<u>QTY.</u>	<u>REMARKS</u>
1	M1413000402	BASE	1	
2	M1413400004	UNDER COVER	1	
3	011008020	HEX. HEAD BOLT	2	REPLACES 0016908020
4	M1423000902	FRONT FRAME	1	S/N7200646 TO 7200740
4	M1423000912	FRONT FRAME	1	S/N7200741~
4	M1493102703	ACOUSTIC SHEET	1	
5	011008020	HEX. HEAD BOLT	4	REPLACES 0016908020
6	M1423200604	COVER, FRONT FRAME	1	
6	M1493100804	ACOUSTIC SHEET	1	
7	011008020	HEX. HEAD BOLT	12	REPLACES 0016908020
8	M1423200703	INNER COVER, FRONT FRAME	1	S/N7200646 TO 7200740
8	M1423200713	INNER COVER, FRONT FRAME	1	S/N7200741~
9	011008020	HEX. HEAD BOLT	6	REPLACES 0016908020
10	M1433000403	CENTER FRAME	1	
11	M1433000003	CENTER FRAME	1	
12	0010114030	HEX. HEAD BOLT	8	
12	030214350	LOCK WASHER	8	REPLACES 0040014000
12	031114260	PLAIN WASHER	8	REPLACES 0041214000
13	012012030	HEX. HEAD BOLT	10	REPLACES 0010112030
13	00400120000	SPRING WASHER	10	
13	031112230	PLAIN WASHER	10	REPLACES 0041212000
14	M1443000702	REAR FRAME	1	
14	M1493300504	ACOUSTIC SHEET	1	
15	011008020	HEX. HEAD BOLT	4	REPLACES 0016908020
15	0040508000	TOOTHED WASHER	1	
16	M1443300613	REAR COVER	1	
17	M1443300303	DUCT, REAR COVER	2	
17	M1493300604	ACOUSTIC SHEET	2	
18	0207006000	HEX. NUT	12	
19	011008020	HEX. HEAD BOLT	9	REPLACES 0016908020
20	M1443200803	REAR DOOR	1	
21	M1443600204	WINDOW PLATE	1	
22	020106050	HEX. NUT	8	REPLACES 0207306000
22	00412060000	PLAIN WASHER	8	
23	B9114000002	DOOR HANDLE ASSY.	1	REPLACES M9113000002
24	0027106016	MACHINE SCREW	4	REPLACES 0021806015
24	020106050	HEX. NUT	4	REPLACES 0030006000
25	M9110100204	HINGE	2	
26	M9116100004	WASHER	2	
27	0021808020	MACHINE SCREW	3	
28	0845031504	BLIND PLUG	2	REPLACES M9310000004
29	M1463000702	ROOF PANEL	1	
29	M1493501503	ACOUSTIC SHEET	1	
30	011008020	HEX. HEAD BOLT	19	REPLACES 0016908020
31	1625165103	BONNET CAP	1	REPLACES M9310000103

DCA-45SSIU2 — ENCLOSURE ASSY. (CONT.)

ENCLOSURE ASSY. (CONT.)

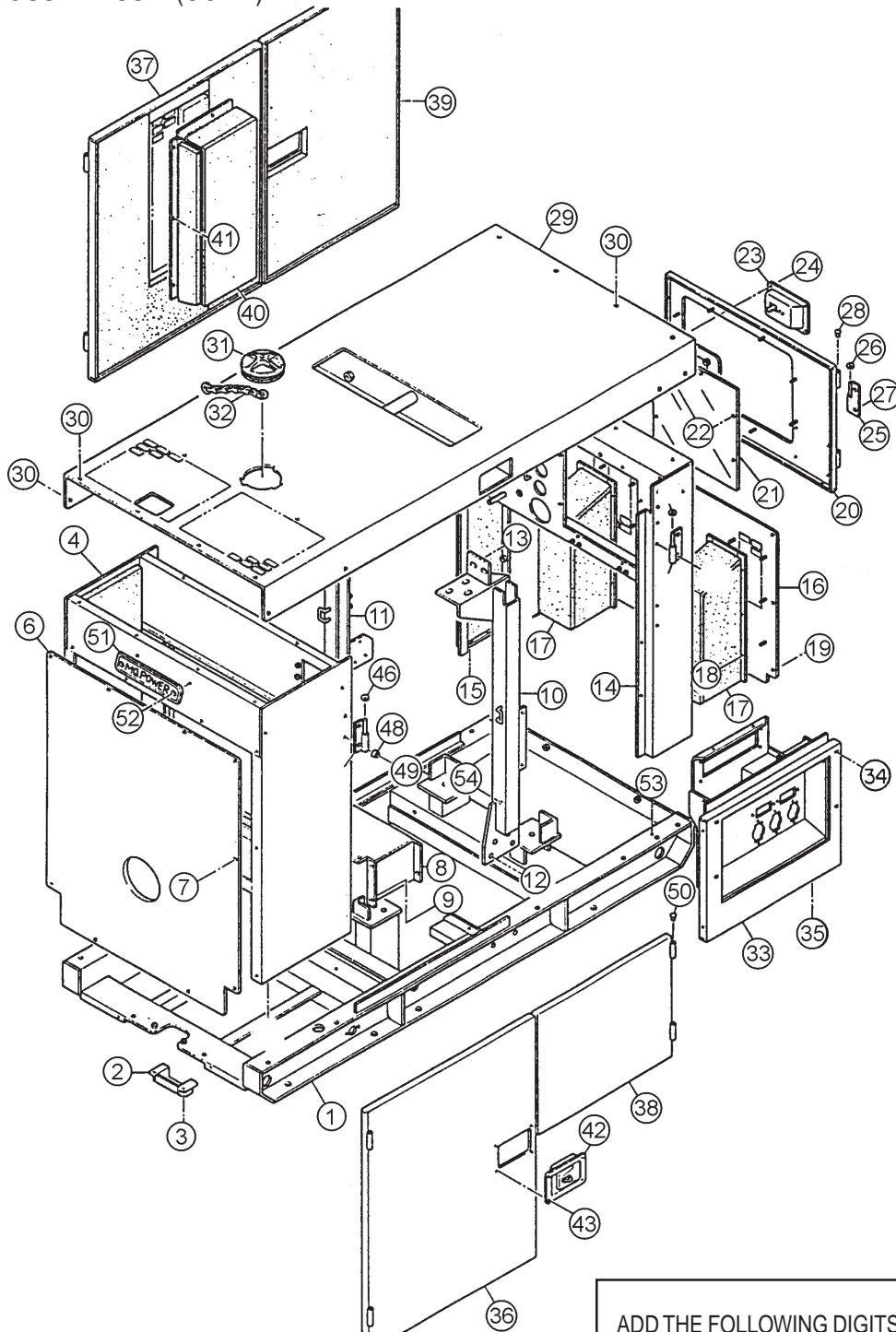

ADD THE FOLLOWING DIGITS AFTER THE PART NUMBER
WHEN ORDERING ANY PAINTED PANEL TO INDICATE
COLOR OF UNIT:

- | | |
|-----------------|----------------------|
| 1-ORANGE | 5-BLACK |
| 2-WHITE | 6-CATERPILLAR YELLOW |
| 3-SPECTRUM GRAY | 7-CATO GOLD |
| 4-SUNBELT GREEN | 8-RED |

THE SERIAL NUMBER MAY BE REQUIRED.

DCA-45SSIU2 — ENCLOSURE ASSY. (CONT.)

ENCLOSURE ASSY. (CONT.)

<u>NO.</u>	<u>PART NO.</u>	<u>ITEM</u>	<u>QTY.</u>	<u>REMARKS</u>
32	1625165204	CHAIN ASSY.	1	REPLACES M1483600204
33	M1453200002	SPLASHER PANEL	1	S/N7200646 TO 7201195
33	M1453200012	SPLASHER PANEL	1	S/N7201196~
33	M1493300204	ACOUSTIC SHEET	1	
34	011208060	HEX. HEAD BOLT	4	REPLACES 0016908055
35	011008020	HEX. HEAD BOLT	2	REPLACES 0016908020
36	M1453001503	SIDE DOOR	1	
36	M1493403104	ACOUSTIC SHEET	1	
37	M1453002003	SIDE DOOR	1	
37	M1493403003	ACOUSTIC SHEET	1	
38	M1453001303	SIDE DOOR	1	
38	M1493400404	ACOUSTIC SHEET	1	
39	M1453001203	SIDE DOOR	1	
39	M1493401404	ACOUSTIC SHEET	1	
40	M1453300603	DUCT	1	
40	M1493401304	ACOUSTIC SHEET	1	
41	0207006000	HEX. NUT	5	
42	B9114000002	DOOR HANDLE ASSY.	3	REPLACES M9113000002
43	0027106016	MACHINE SCREW	12	REPLACES 0021806015
43	020106050	HEX. NUT	12	REPLACES 0030006000
44	M9110100204	HINGE	4	
45	M9110100304	HINGE	4	
46	M9116100004	WASHER	8	
47	0021808020	MACHINE SCREW	9	
48	0601850097	DOOR STOPPER	8	
49	0027208025	MACHINE SCREW	8	
50	0845031504	BLIND PLUG	8	REPLACES M9310000004
51	0600500090	EMBLEM	1	
52	0021106015	MACHINE SCREW	2	
53	011008020	HEX. HEAD BOLT	1	REPLACES 0016908020
53	0040508000	TOOTHED WASHER	1	
54	0016910020	HEX. HEAD BOLT	1	
54	0040510000	TOOTHED WASHER	1	

DCA-45SSIU2 — RUBBER SEAL ASSY.

RUBBER SEAL ASSY.

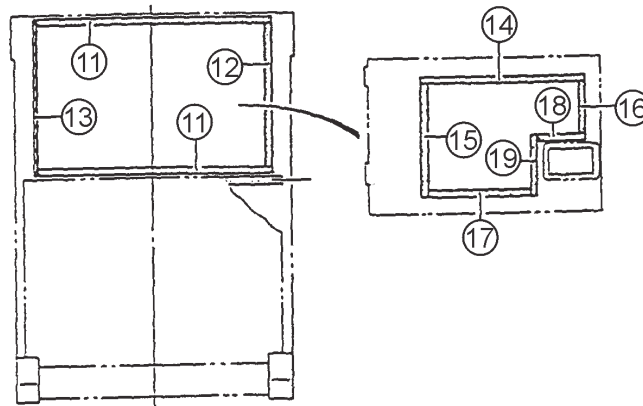
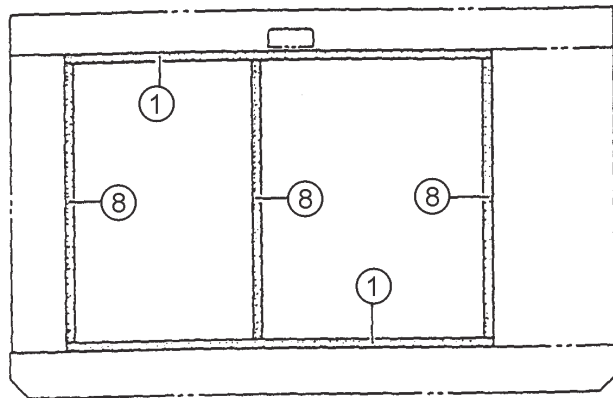
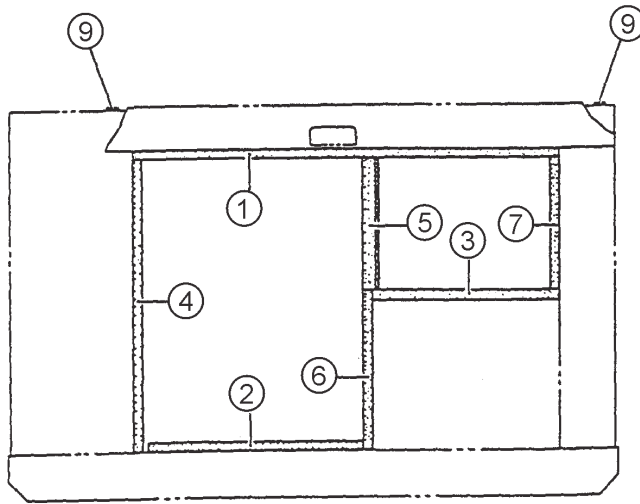

DCA-45SSIU2 — RUBBER SEAL ASSY.

RUBBER SEAL ASSY.

<u>NO.</u>	<u>PART NO.</u>	<u>ITEM</u>	<u>QTY.</u>	<u>REMARKS</u>
1	0228901400	RUBBER SEAL	3	
2	0229200695	RUBBER SEAL	1	
3	0228900620	RUBBER SEAL	1	
4	0228900940	RUBBER SEAL	1	
5	M1490300104	RUBBER SEAL	1	
6	0228800515	RUBBER SEAL	1	
7	0228900420	RUBBER SEAL	1	
8	0228900910	RUBBER SEAL	3	
9	0229200900	RUBBER SEAL	1	
10	0229200840	RUBBER SEAL	1	
11	0228800780	RUBBER SEAL	2	
12	0228800470	RUBBER SEAL	1	
13	0228800510	RUBBER SEAL	1	
14	0228100545	RUBBER SEAL	1	
15	0228100370	RUBBER SEAL	1	
16	0228100165	RUBBER SEAL	1	
17	0228100340	RUBBER SEAL	1	
18	0228100170	RUBBER SEAL	1	
19	0228100200	RUBBER SEAL	1	

DCA-45SSIU2 — NAMEPLATE AND DECALS

NAMEPLATE AND DECALS

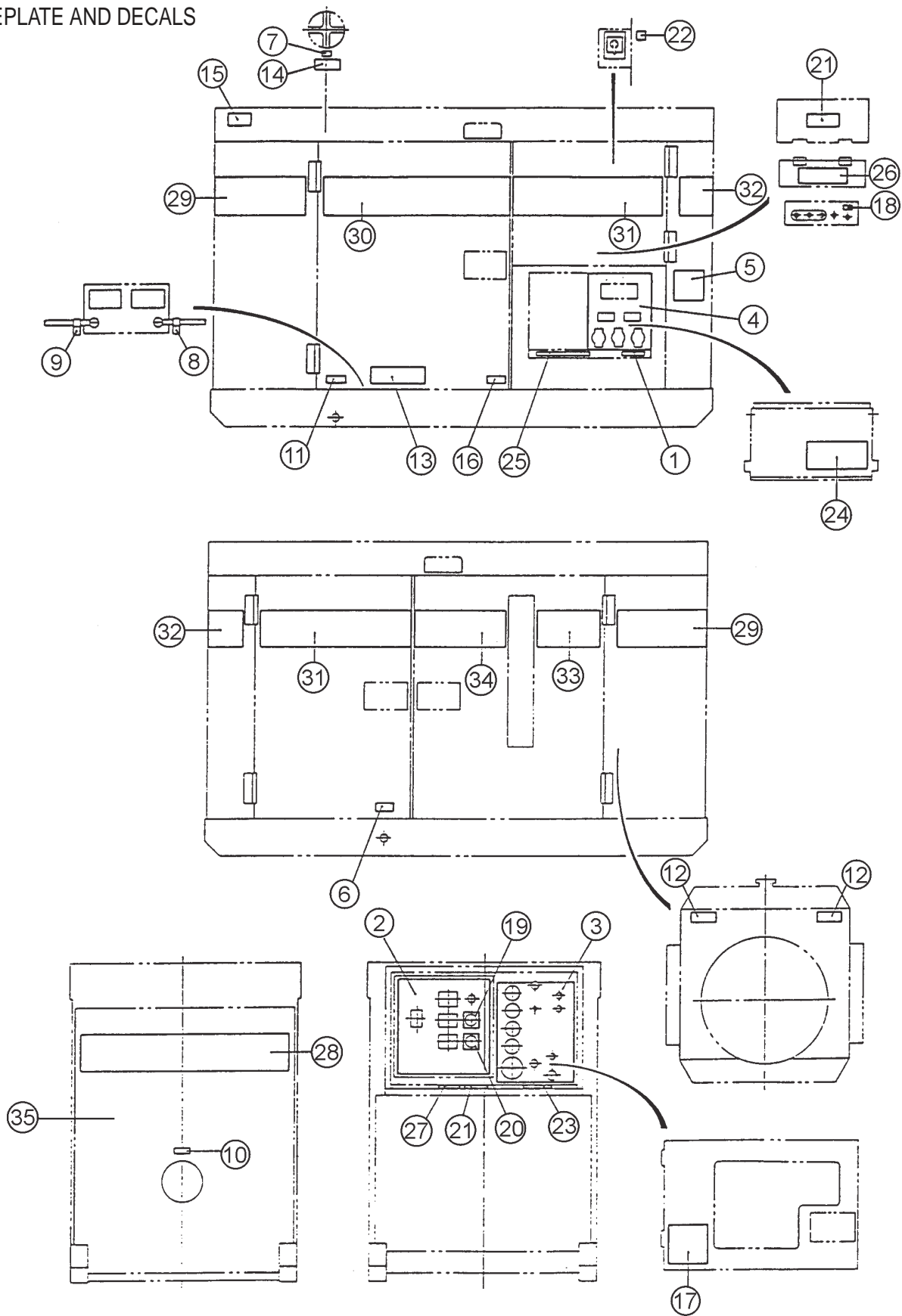

DCA-45SSIU2 — NAMEPLATE AND DECALS

NAMEPLATE AND DECALS

<u>NO.</u>	<u>PART NO.</u>	<u>ITEM</u>	<u>QTY.</u>	<u>REMARKS</u>
1	M1550000204	DECAL, NOTE	1	M15000020
2	M1550001003	DECAL, GENERATOR CONTROL	1	M15000100
3	M1550000603	DECAL, ENGINE OPERATING	1	M15000060
4	M1550000703	DECAL, AUXILIARY OUTPUT	1	M15000070
5	M1550000804	DECAL, NOTE	1	M15000080
6	M9500000004	DECAL, OIL DRAIN PLUG	1	M9000000
7	M9500100004	DECAL, WATER	1	M90010000
8	M9500300004	DECAL, -	1	M90030000
9	M9500300104	DECAL, +	1	M90030010
10	M9500500004	DECAL, DIESEL FUEL	1	M90050000
11	M9500500104	DECAL, FUEL DRAIN PLUG	1	M90050010
12	M9503000004	DECAL, WARNING	2	M90300000
13	M9503000103	DECAL, WATER, OIL CHECK	1	M90310000
14	M9503100004	DECAL, WARNING	1	M90320000
15	M9503200004	DECAL, WARNING	1	M90320000
16	M9510100004	DECAL, CAUTION	1	M91010000
17	M9510200002	DECAL, MQ	1	M91020000
18	M9520000004	DECAL, GROUND	1	M92000000
19	M9520000104	DECAL, AMMETER CHANGE-OVER SWITCH	1	M92000010
20	M9520000204	DECAL, VOLTMETER CHANGE-OVER SWITCH ..	1	M92000020
21	M9520100004	DECAL, WARNING	2	M92010000
22	M9520100204	DECAL, CAUTION	1	M92010020A
23	M9520100304	DECAL, SAFETY INSTRUCTIONS	1	M92010030
24	M9520100404	DECAL, DANGER	1	M92010040
25	M9520100503	DECAL, WARNING	1	M92010050
26	M9520200003	DECAL, CONNECTION OF OUTPUT CABLE	1	M92020000
27	M9520200104	DECAL, OVER CURRENT RELAY	1	M92020010
28	M1560100603	STRIPE, WHISPERWATT	1	
29	M1560100703	STRIPE, MQ POWER	2	
30	M1560101204	STRIPE	1	
31	M1560101104	STRIPE	2	
32	M1560100904	STRIPE, 45	2	
33	M1560100804	STRIPE	1	
34	M1560101004	STRIPE	1	
35	M1940011015Q	DECAL, FUELING PROCEDURE	1	

ISUZU 4BG1 — CYLINDER HEAD COVER ASSY.

CYLINDER HEAD COVER ASSY.

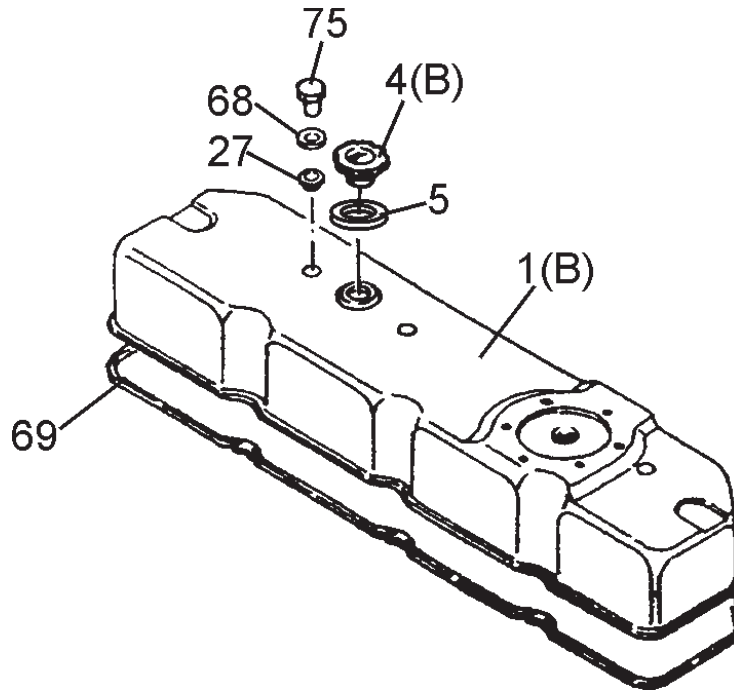

ISUZU 4BG1 — CYLINDER HEAD COVER ASSY.

CYLINDER HEAD COVER ASSY.

<u>NO</u>	<u>PART NO</u>	<u>PART NAME</u>	<u>QTY.</u>	<u>REMARKS</u>
1	8971334460	COVER	1	
4	8941332075	CAP	1	
5	8941236231	GASKET, OIL FILLER	1	
27	9111790300	GASKET, HEAD COVER	3	
68	9111791050	WASHER	3	
69	8943109120	GASKET, HEAD TO COVER	1	REPLACES 8944625590
75	9111750120	NUT	3	

ISUZU 4BG1 — CYLINDER HEAD ASSY.

CYLINDER HEAD ASSY.

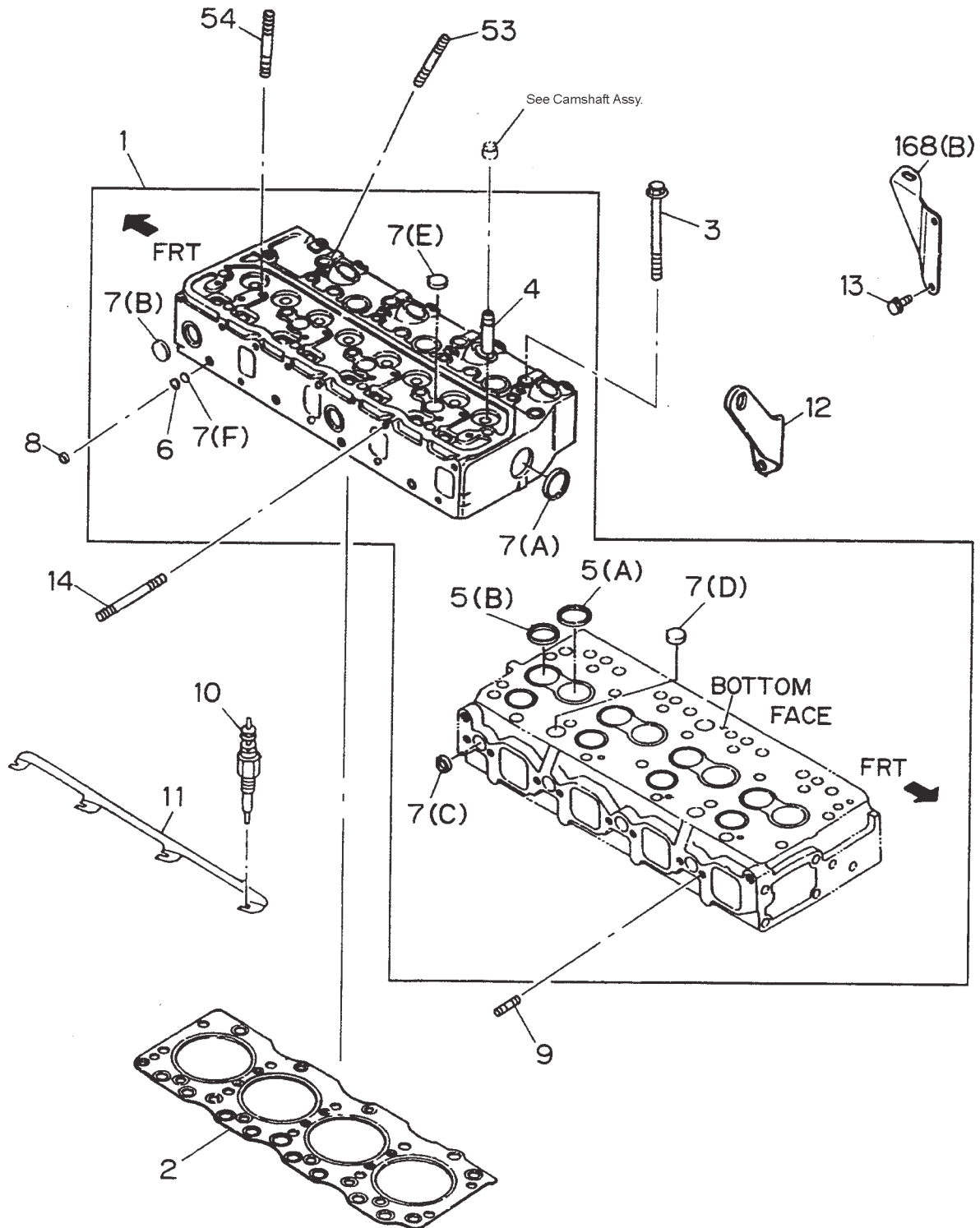

ISUZU 4BG1 — CYLINDER HEAD ASSY.

CYLINDER HEAD ASSY.

<u>NO</u>	<u>PART NO</u>	<u>PART NAME</u>	<u>QTY.</u>	<u>REMARKS</u>
1	8971418211	CYLINDER HEAD ASSY.	1	INCLUDES ITEM W/*
2	8944189200	GASKET, HEAD	1	
3	8943674380	BOLT	4	M12X 115
3	8943674370	BOLT	4	M12X102
4*	5117510010	GUIDE, VALVE	8	
5A*	8970376860	VALVE INSERT SEAT, INLET	4	
5B*	5117110280	VALVE, INSERT SEAT, EXHAUST	4	
6*	9096600340	PLUG PLATE	4	
7A*	1096000051	SEALING CYL. HEAD CUP	1	OD=45
7B*	5112190150	SEALING CYL. HEAD CUP	2	OD=32
7C*	1096000160	SEALING CYL. HEAD CUP	4	OD-25
7D*	9111291280	SEALING CYL. HEAD CUP	2	OD=20
7E*	1096000160	SEALING CYL. HEAD CUP	3	OD=25
7F*	5096000130	SEALING CYL. HEAD CUP	4	OD=12.3
8	9111296010	CUP, SEALING WATER JACKET	4	
9	9041108250	INLET MANIFOLD STUD	2	
10	9825139289	GLOW PLUG	4	
11	5197320021	GLOW PLUG CONNECTOR	1	
12	9117778050	REAR ENG. HANGER	1	
13	0500410200	HANGER BOLT	4	
14	9041108750	STUD, EX. MANIFOLD	3	M8X75 L=87
14	9098301770	STUD, EX. MANIFOLD	1	M8X85 L=97
53	1093000180	INJ. NOZZLE STUD	8	
54	5093000650	ROCKER ARM STUD	3	
168	5117770640	FRONT ENG. HANGER	1	

ISUZU 4BG1 — CYLINDER BLOCK ASSY.

CYLINDER BLOCK ASSY.

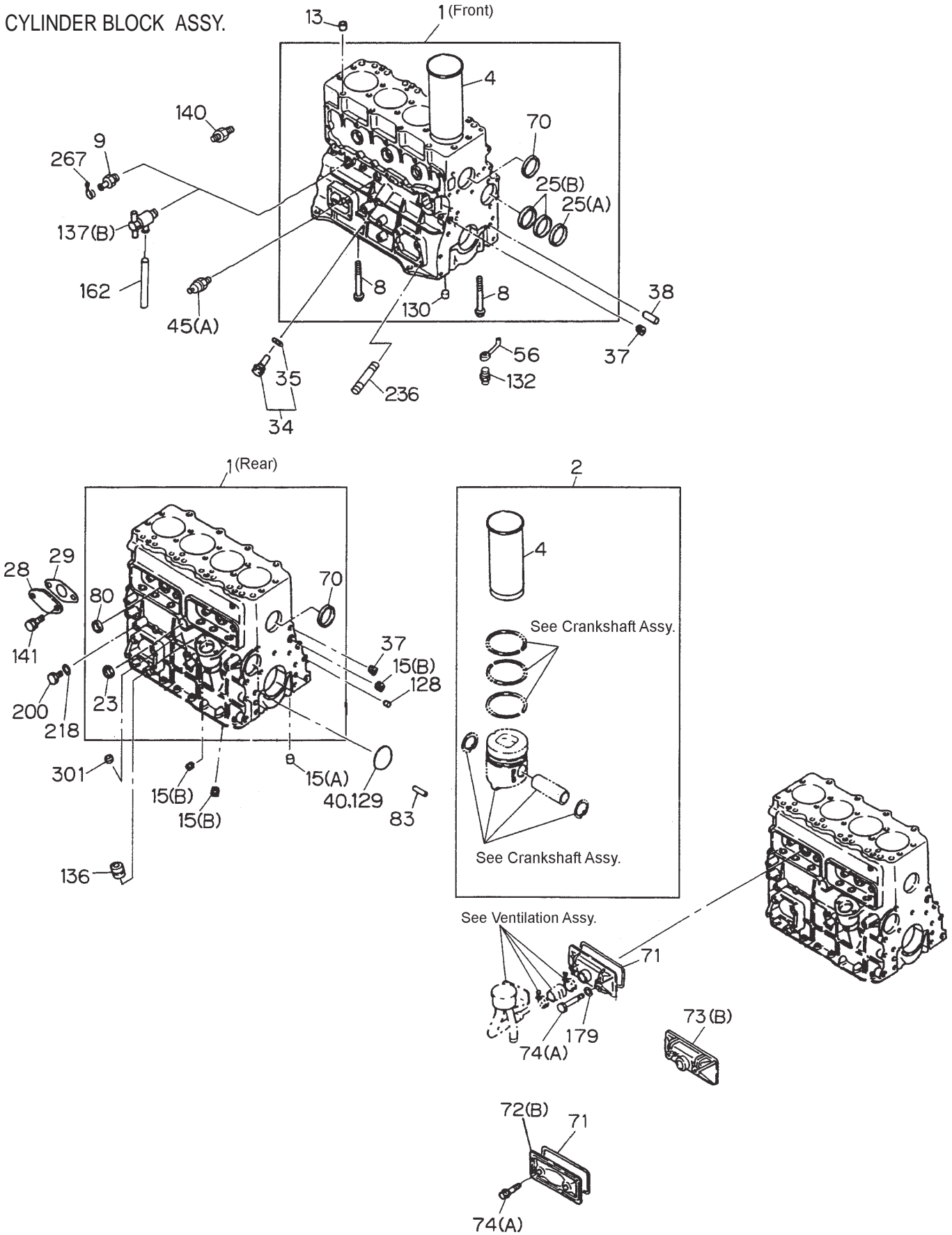

ISUZU 4BG1 — CYLINDER BLOCK ASSY.

CYLINDER BLOCK ASSY.

<u>NO.</u>	<u>PART NO.</u>	<u>PART NAME</u>	<u>QTY.</u>	<u>REMARKS</u>
1	8971239542	CYLINDER BLOCK ASSY.	1	INCLUDES ITEM W/*
2	5878133000	LINER SET	1	GRADE 1
2	4878133010	LINER SET	1	GRADE 2
2	4878133020	LINER SET	1	GRADE 3
2	5878133030	LINER SET	1	GRADE 4
4*	1112612480	LINER, CYLINDER BLOCK	4	OD GRD=1 ID GRD=AX
4*	1112612490	LINER, CYLINDER BLOCK	4	OD GRD=1 ID GRD=CX
4*	1112612500	LINER, CYLINDER BLOCK	4	OD GRD=2 ID GRD=AX
4*	1112612520	LINER, CYLINDER BLOCK	4	OD GRD=2 ID GRD=CX
4*	1112612520	LINER, CYLINDER BLOCK	4	OD GRD=3 ID GRD=AX
4*	1112612530	LINER, CYLINDER BLOCK	4	OD GRD=3 ID GRD=CX
4*	1112612540	LINER, CYLINDER BLOCK	4	OD GRD=4 ID GRD=AX
4*	1112612550	LINER, CYLINDER BLOCK	4	OD GRD=4 ID GRD=CX
8*	1090004691	BOLT	2	
13	8941480790	DOWEL	2	
15A	9992055170	OIL GALLERY PLUG	1	PT 3/8
15B	5096050180	OIL GALLERY PLUG	7	PT 1/8 (SQUARE HEAD)
23*	5112190140	CUP, SEALING	1	
25A*	9116110480	CAMSHAFT METAL	1	
25B*	9116130350	CAMSHAFT METAL	2	
28	8941745290	OIL PORT COVER	1	
29	8943706630	OIL PORT COVER GASKET	1	
34	8970233390	OIL RELIEF VALVE	1	
35	5096230350	OIL RELIEF GASKET	1	
37	1096050681	OIL GALLERY PLUG	2	
38	1097400780	TIMING GEAR CASE PIN	1	
40	8943444620	SEALING CUP	1	
45	9827200690	OIL PRESSURE SWITCH	1	
56	1133420742	PISTON COOLING OIL JET	4	
70*	1096000520	SEALING CUP	2	
71	8943673681	GASKET	2	
72	8970285250	TAPPET CHAMBER COVER	1	
73	9112916051	TAPPET CHAMBER ASSY.	1	
74	8943675301	BOLT		
80*	1096000121	TAPPET CHAMBER SEALING CUP	2	
83	9081510180	FLYWHEEL HOUSING PIN	2	
130*	5112570011	BRIDGE CAP DOWEL	1	
132	1131610120	OIL CHECK VALVE	4	
136	5112240040	OIL PUMP SHAFT DRIVE BUSHING	1	
137	5096800110	WATER DRAIN COCK	1	
140	5096600330	INJ. PUMP NIPPLE	1	
141	0500408180	BOLT, COVER	2	
162	1093660330	CYL. BLOCK WATER DRAIN HOSE	1	REPLACES 9099135050
179	9095720080	GASKET	4	
200	9992023140	OIL GALLERY PLUG	1	
218	9095720140	GASKET PLUG	1	
236	1093000790	ENGINE FOOT STUD	1	
267	5097070041	DRAIN HOSE CLIP	1	
301	5111290030	SEALING LEVEL GAUGE CUP	1	

ISUZU 4BG1 — OIL PAN AND LEVEL GAUGE ASSY.

OIL PAN AND LEVEL GAUGE ASSY.

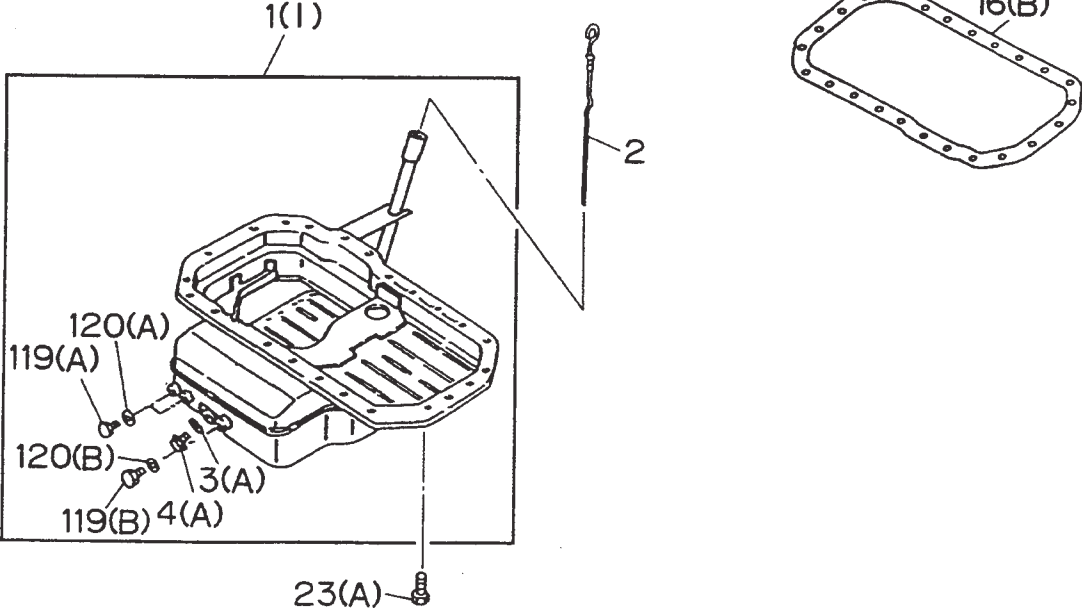

See and Oil and Vacuum Assy.

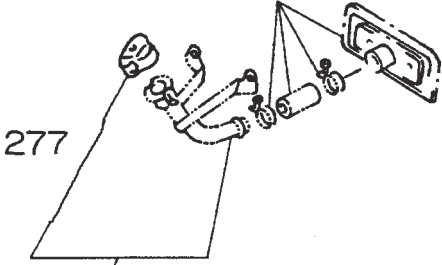

See and Oil and Vacuum Assy.

ISUZU 4BG1 — OIL PAN AND LEVEL GAUGE ASSY.

OIL PAN AND LEVEL GAUGE ASSY.

<u>NO.</u>	<u>PART NO.</u>	<u>PART NAME</u>	<u>QTY.</u>	<u>REMARKS</u>
1	8941340361	OIL PAN ASSEMBLY	1	INCLUDES ITEM W/*
2	5117601500	OIL LEVEL GAUGE	1	
3*	1096230570	DRAIN PLUG GASKET	1	
4*	9096620120	OIL DRAIN PLUG	1	
16	8943706660	OIL PAN GASKET	1	
23	0500408180	BOLT	24	
119A*	9992023160	OIL HEATER BLIND PLUG	2	
119B*	9992023240	OIL HEATER BLIND PLUG	1	
120A*	9095714160	GASKET	2	
120B*	9095714240	GASKET	1	
277	1117500120	OIL FILLER CAP	1	

ISUZU 4BG1 — CAMSHAFT AND VALVE ASSY.

CAMSHAFT AND VALVE ASSY.

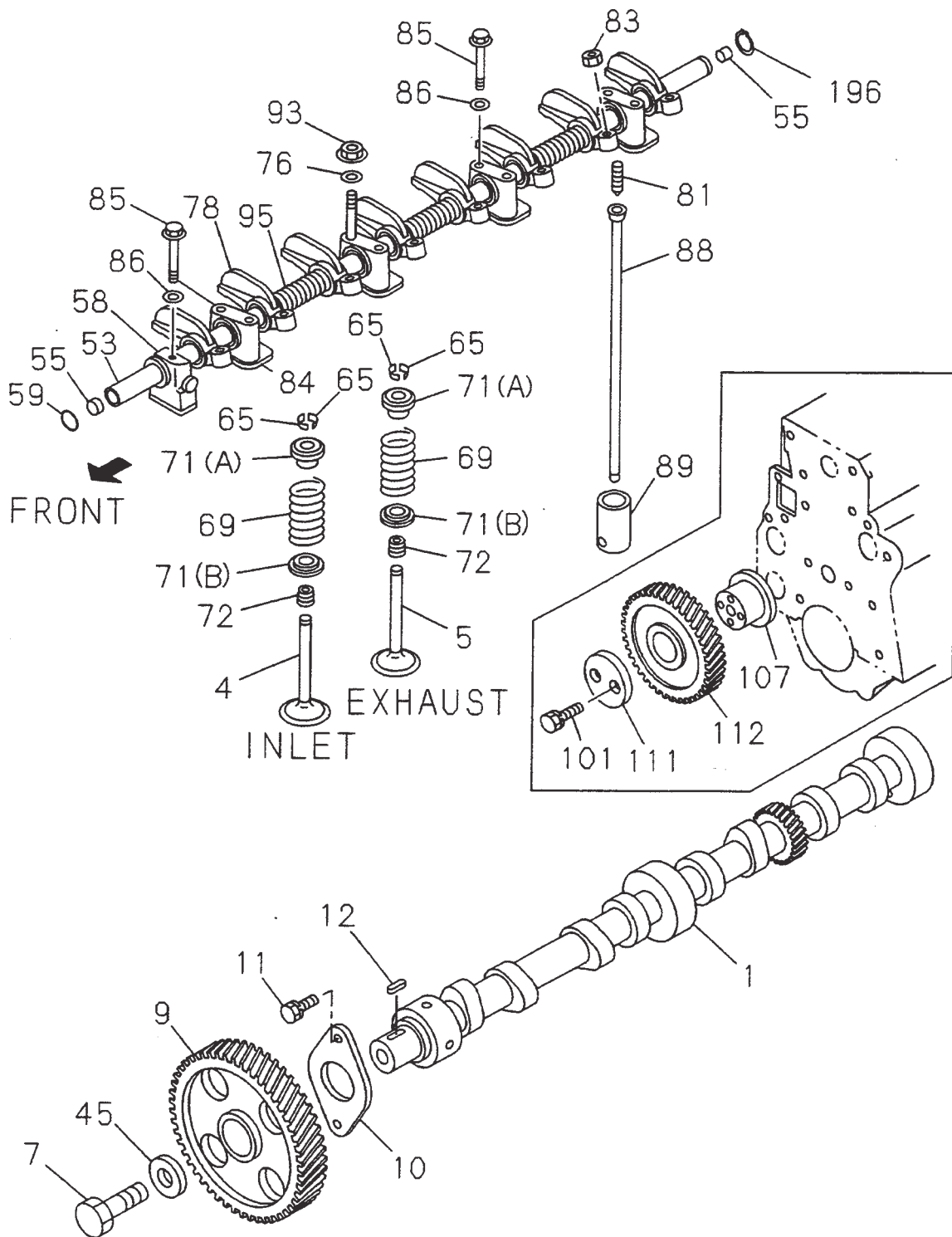

ISUZU 4BG1 — CAMSHAFT AND VALVE ASSY.

CAMSHAFT AND VALVE ASSY.

<u>NO.</u>	<u>PART NO.</u>	<u>PART NAME</u>	<u>QTY.</u>	<u>REMARKS</u>
1	8944094120	CAMSHAFT	1	
4	1125510501	INLET VALVE	4	
5	1125520251	EXHAUST VALVE	4	
7	5090002360	BOLT	1	
9	1125220161	CAMSHAFT GEAR	1	
10	9116810150	THRUST PLATE	1	
11	0500408250	BOLT	2	
12	9080107200	KEY	1	
45	9098518503	WASHER	1	
53	8941295510	ROCKER ARM SHAFT	1	
55	9126260050	ROCKER ARM PLUG	2	
58	5126280120	ROCKER ARM BRACKET	1	
59	5096230600	ROCKER SHAFT GASKET	1	
65	5125650060	SPLIT COLLAR	16	
69	5125610090	OUTER VALVE SPRING	8	
71A	8941145790	SPRING SEAT, UPPER	8	
71B	1125630351	SPRING SEAT, LOWER	8	
72	1125690150	VALVE GUIDE SEAT	8	
76	9098514300	WASHER	3	
78	5126110310	ROCKER ARM	8	
81	9126160420	ADJ. SCREW	8	
83	9091115080	ADJ. SCREW NUT	8	
84	9126281050	ROCKER SHAFT BRACKET	4	
85	1090005670	BOLT	6	
86	9098514300	WASHER	6	
88	1125750360	PUSH ROD	8	
89	5125710032	VALVE TAPPET	8	
93	1094001160	NUT	3	
95	1095803350	ROCKER SHAFT SPRING	3	
101	5090300381	BOLT	2	
107	9125310300	IDLE GEAR SHAFT	1	
111	5125350011	THRUST COLLAR	1	
112	8941339372	IDLER GEAR	1	
196	9091800190	SNAP RING	1	

ISUZU 4BG1 — CRANKSHAFT, PISTON AND FLYWHEEL ASSY.

CRANKSHAFT, PISTON AND FLYWHEEL ASSY.

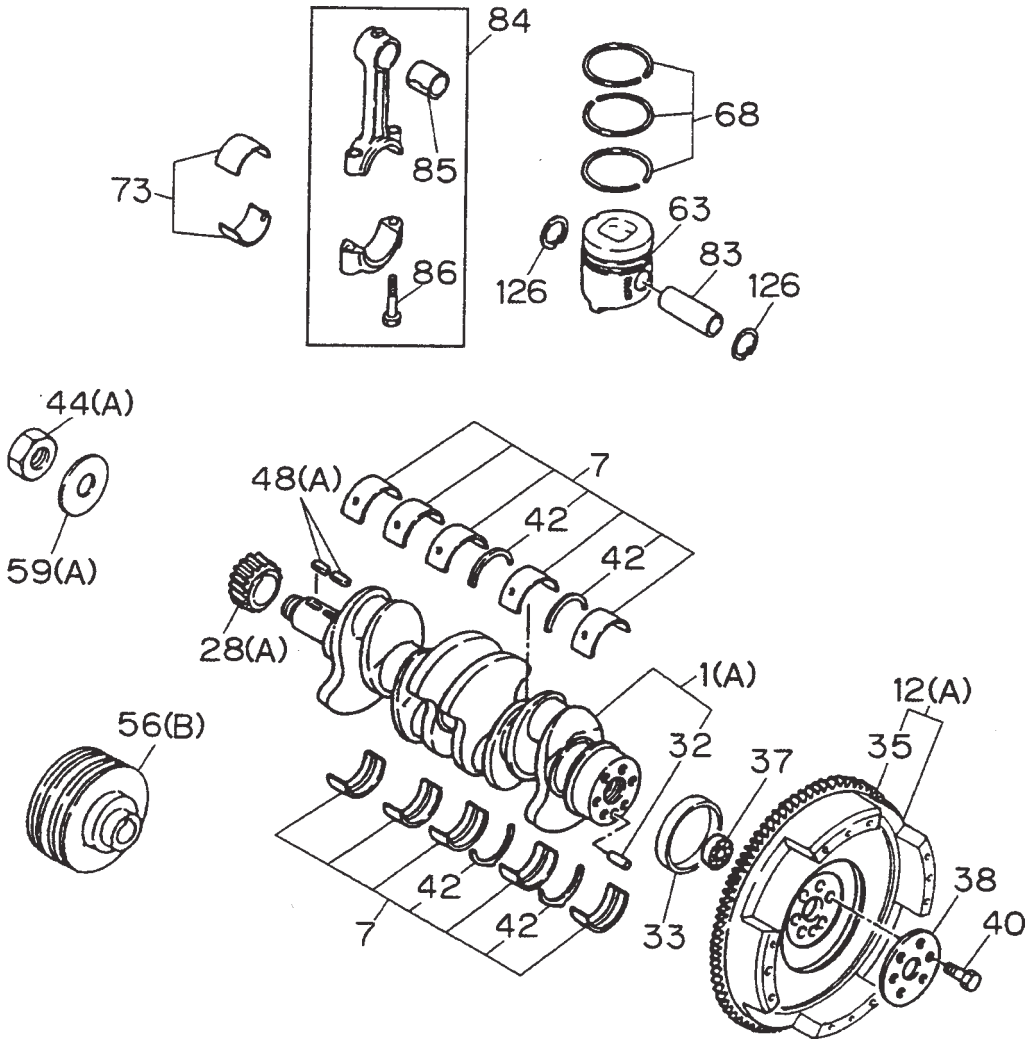

ISUZU 4BG1 — CRANKSHAFT, PISTON AND FLYWHEEL ASSY.

CRANKSHAFT, PISTON AND FLYWHEEL ASSY.

<u>NO</u>	<u>PART NO</u>	<u>PART NAME</u>	<u>QTY.</u>	<u>REMARKS</u>
1	8943398950	CRANKSHAFT	1	
7	8970716610	CRANKSHAFT, STD KIT	1	INCLUDES ITEM W/# REPLACES 8941170322
12	8970461810	FLYWHEEL	1	
28	8971379100	CRANKSHAFT GEAR	1	
32	9081612200	FLYWHEEL PIN	1	
33	5123190032	CRANKSHAFT RING	1	
35	9123336070	GEAR RING	1	
37	9000901570	PILOT BEARING	1	
38	5123360030	WASHER	1	
40	5123340060	BOLT	6	
42#	8970713580	WASHER	2	REPLACES 8941145652
44	5123780020	NUT	1	
48	8941075970	KEY	2	
56	8941004540	CRK DAMPER PULLEY	1	
59	5095030240	WASHER	1	
63	8971766500	PISTON, STD.	4	GRADE=AX
63	8971766510	PISTON, STD.	4	GRADE=CX
68	8971238330	RING SET	4	
73	9122716080	CONN. ROD METAL SET	4	
83	912211604	PISTON PIN	4	
84	1122301041	CONNECTING ROD ASSY.	4	INCLUDES ITEMS W/\$
85\$	1122510270	BUSHING	4	
86\$	1122350271	BOLT	8	
126	8941075751	SNAP PIN RING	8	

ISUZU 4BG1 — TIMING GEAR AND FLYWHEEL HOUSING ASSY.

TIMING GEAR AND FLYWHEEL HOUSING ASSY.

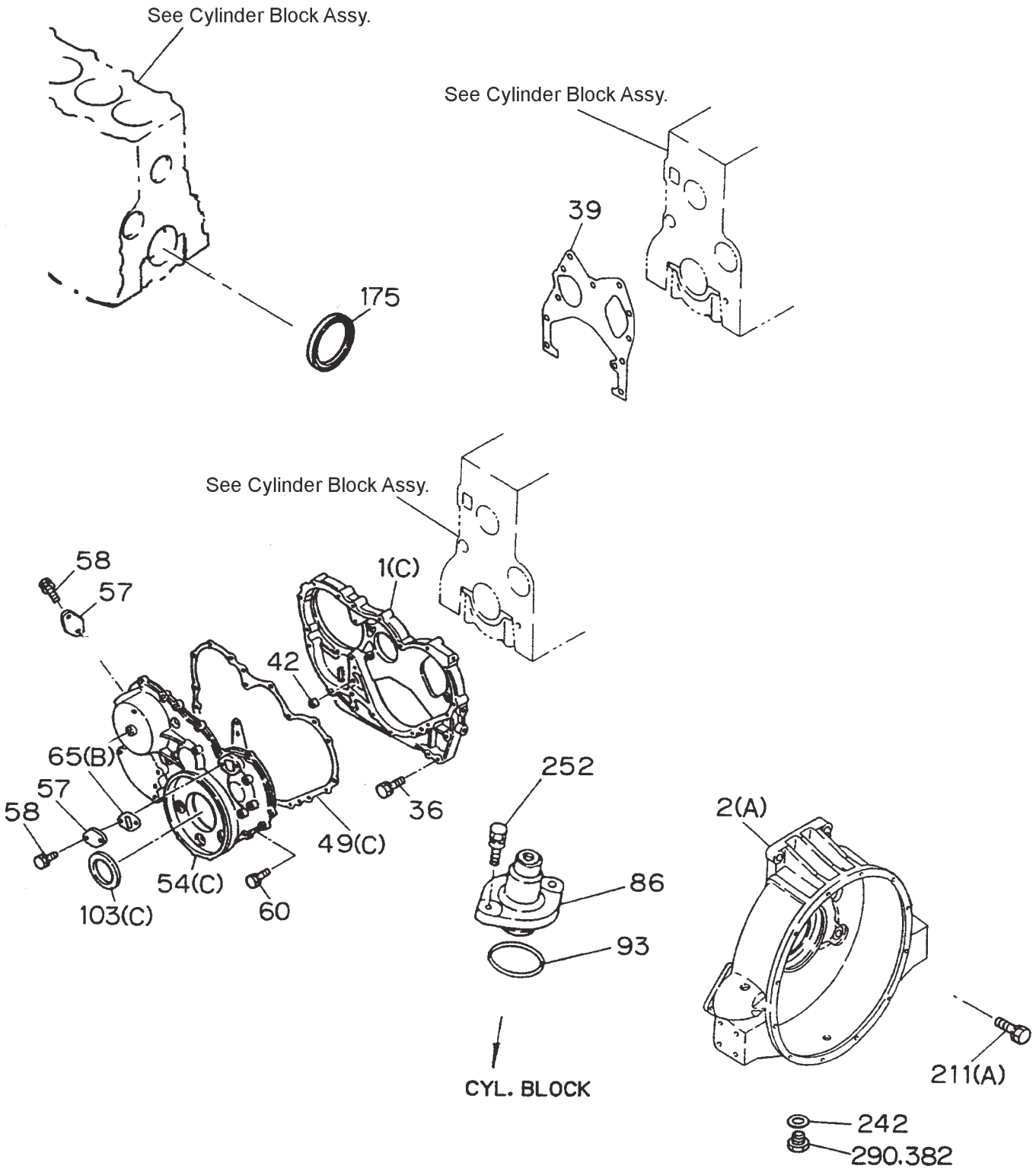

ISUZU 4BG1 — TIMING GEAR AND FLYWHEEL HOUSING ASSY.

TIMING GEAR AND FLYWHEEL HOUSING ASSY.

<u>NO.</u>	<u>PART NO.</u>	<u>PART NAME</u>	<u>QTY.</u>	<u>REMARKS</u>
1	8944509752	TIMING GEAR CASE	1	
2	8943213304	FLYWHEEL HOUSING	1	
36	0500408200	BOLT	4	M8X20 W/ LOCK WASHER
36	0500408450	BOLT	2	M8X45 W/ LOCK WASHER
39	8943706710	GASKET	1	
42	9112290581	DOWEL	1	
49	8943706720	GASKET	1	
54	8971298300	GEAR CASE COVER	1	
57	5113210090	TIMING CHECK COVER	2	
58	0500406140	BOLT	4	
60	0500408250	BOLT	8	MX45 W/ LOCK WASHER
60	0500408800	BOLT	1	M8X80W/ LOCK WASHER
60	5090000841	BOLT	4	M8X55 W/LOCK WASHER
60	5090300381	BOLT	3	M10X55
65	8970276011	GASKET	2	
86	8944533001	TACHO DRIVE ELBOW	1	
93	1096234650	ELBOW GASKET	1	
103	1096254380	OIL SEAL, FRONT	1	
175	1096253630	OIL SEAL, REAR	1	
211	0500408250	BOLT	7	
242	9095714160	PLUG GASKET	1	
252	0500408200	BOLT	2	
290	8943218380	PLUG	1	
382	9992023160	HOUSING PLUG	1	

ISUZU 4BG1 — ENGINE MOUNTING ASSY.

ENGINE MOUNTING ASSY

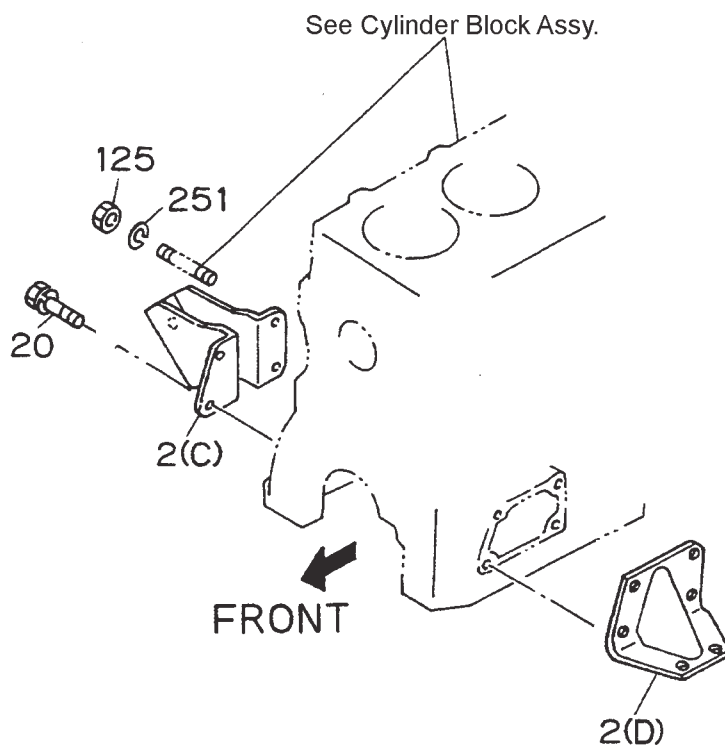

ISUZU 4BG1 — ENGINE MOUNTING ASSY.

ENGINE MOUNTING ASSY.

<u>NO.</u>	<u>PART NO.</u>	<u>PART NAME</u>	<u>QTY.</u>	<u>REMARKS</u>
2C	9117712470	ENGINE FOOT, RIGHT	1	
2D	9117712480	ENGINE FOOT, LEFT	1	
20	8943134650	BOLT	7	
125	9091105100	NUT	1	
251	9091505100	LOCKWASHER	1	

ISUZU 4BG1 — INLET MANIFOLD ASSY.

INLET MANIFOLD ASSY.

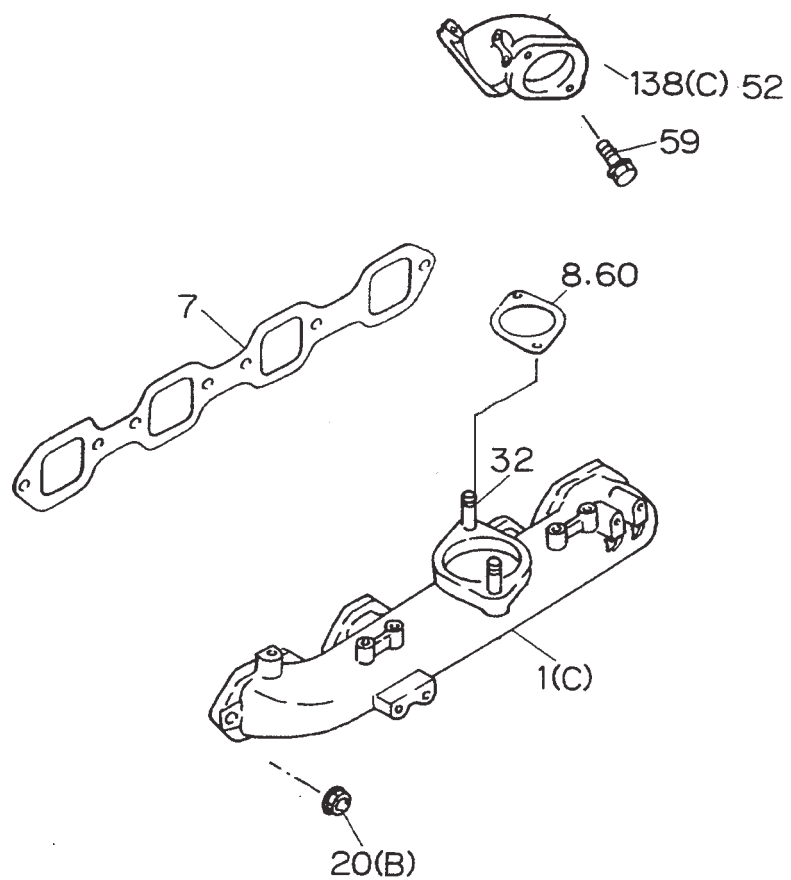

ISUZU 4BG1 — INLET MANIFOLD ASSY.

INLET MANIFOLD ASSY.

<u>NO.</u>	<u>PART NO.</u>	<u>PART NAME</u>	<u>QTY.</u>	<u>REMARKS</u>
1	8971333280	INLET MANIFOLD	1	
7	8970241220	GASKET	1	
20	0911501080	NUT	2	
52	8943216751	INLET PIPE	1	
59	0500510300	BOLT	2	M10X30 W/ LOCK WASHER
59	0501510300	BOLT	2	M10X30 W/ LOCK WASHER
60	8943706760	GASKET	1	
60	8970225710	GASKET	1	
138	5141111970	INLET PIPE	1	
144	0500408250	BOLT	6	

ISUZU 4BG1 — EXHAUST MANIFOLD ASSY.

EXHAUST MANIFOLD ASSY.

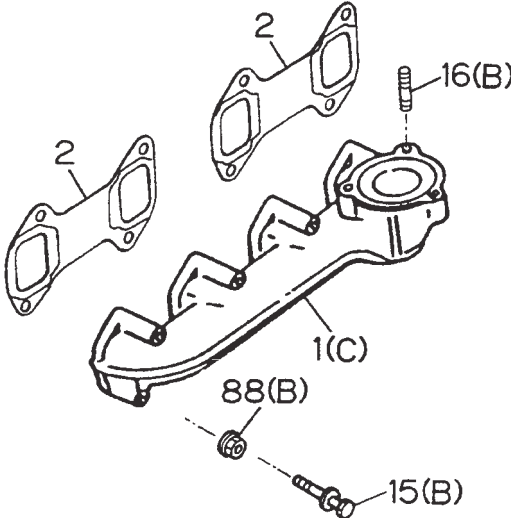

ISUZU 4BG1 — EXHAUST MANIFOLD ASSY.

EXHAUST MANIFOLD ASSY.

<u>NO.</u>	<u>PART NO.</u>	<u>PART NAME</u>	<u>QTY.</u>	<u>REMARKS</u>
1	5141410360	EXHAUST MANIFOLD	1	
2	8944046100	GASKET	2	
15	8943185540	BOLT	1	M8X63 W/PLAIN WASHER
15	8943185550	BOLT	3	M8X75 W/ PLAIN WASHER
16	9044110300	EXHAUST PIPE STUD	3	
88	8941704860	NUT	4	

ISUZU 4BG1 — VENTILATION ASSY.

VENTILATION ASSY.

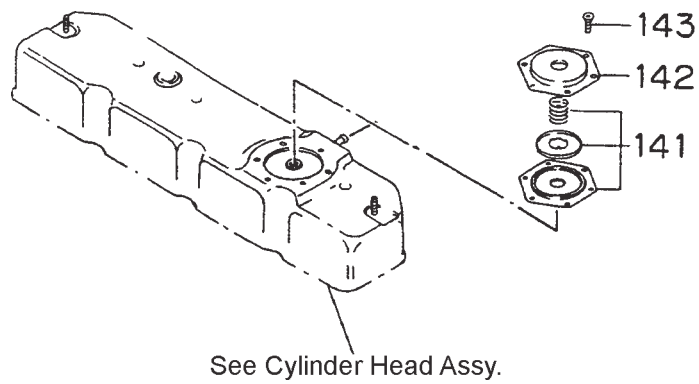

ISUZU 4BG1 — VENTILATION ASSY.

VENTILATION ASSY.

<u>NO.</u>	<u>PART NO.</u>	<u>PART NAME</u>	<u>QTY.</u>	<u>REMARKS</u>
141	894110110	DIAPHRAGM ASSY.	1	
142	1143620020	PCV COVER	1	
143	9934905100	SCREW	6	

ISUZU 4BG1 — WATER PUMP AND CORROSION RESISTOR ASSY.

WATER PUMP AND CORROSION RESISTOR ASSY.

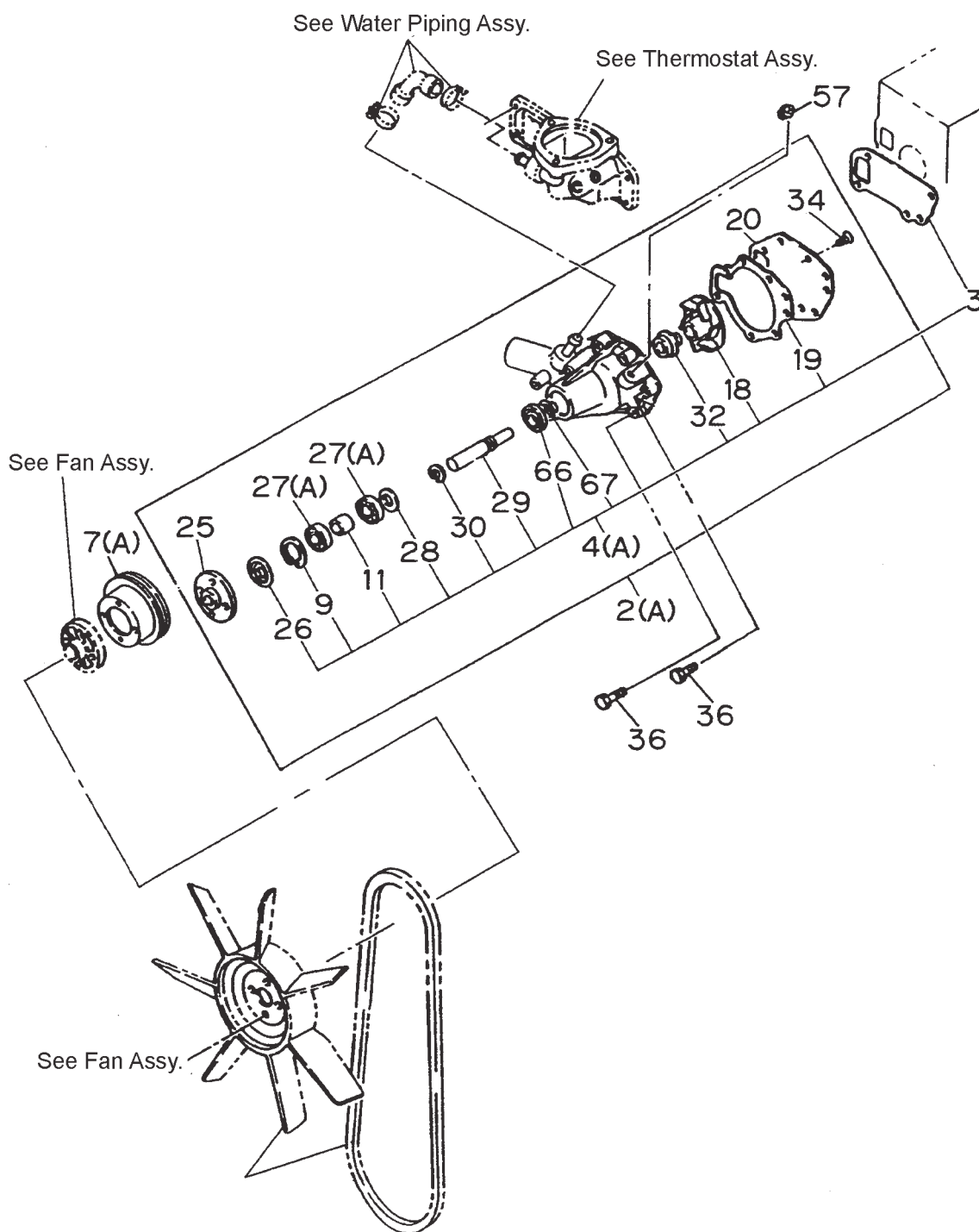

ISUZU 4BG1 — WATER PUMP AND CORROSION RESISTOR ASSY.

WATER PUMP AND CORROSION RESISTOR ASSY.

<u>NO.</u>	<u>PART NO.</u>	<u>PART NAME</u>	<u>QTY.</u>	<u>REMARKS</u>
2	8971250510	WATER PUMP ASSY.	1	INCLUDES ITEMS W/*
3#	8943706610	GASKET	1	
4*	8943809470	REPAIR KIT	1	INCLUDES ITEMS W/#
7	8944161302	WATER PUMP PULLEY	1	
9*#	9091801470	RING	1	
18*#	5136210110	WATER PUMP IMPELLER	1	
19*#	5136130070	GASKET	1	
20*#	5136120100	COVER	1	
25*#	5136420530	CENTER	1	
26*#	5136390020	DUST COVER	1	
27*#	5098000520	BEARING	2	
28*#	5095030990	WASHER	1	
29*#	8943777860	SHAFT	1	
30*#	9099521030	SNAP RING	1	
32*#	5136200061	SEAL	1	
34*#	9090908200	SCREW	3	
36	0500410400	BOLT	1	M10X40 W/LOCK WASHER
36	5090300101	BOLT	2	M10X75 W/LOCK WASHER
36	0500410500	BOLT	1	M10X50 W/ LOCK WASHER
57	5096050050	HEATER PLUG	1	
66*#	5096250780	SECONDARY SEAL	1	
67*#	5136390070	SLINGER	1	

ISUZU 4BG1 — THERMOSTAT AND HOUSING ASSY.

THERMOSTAT AND HOUSING ASSY.

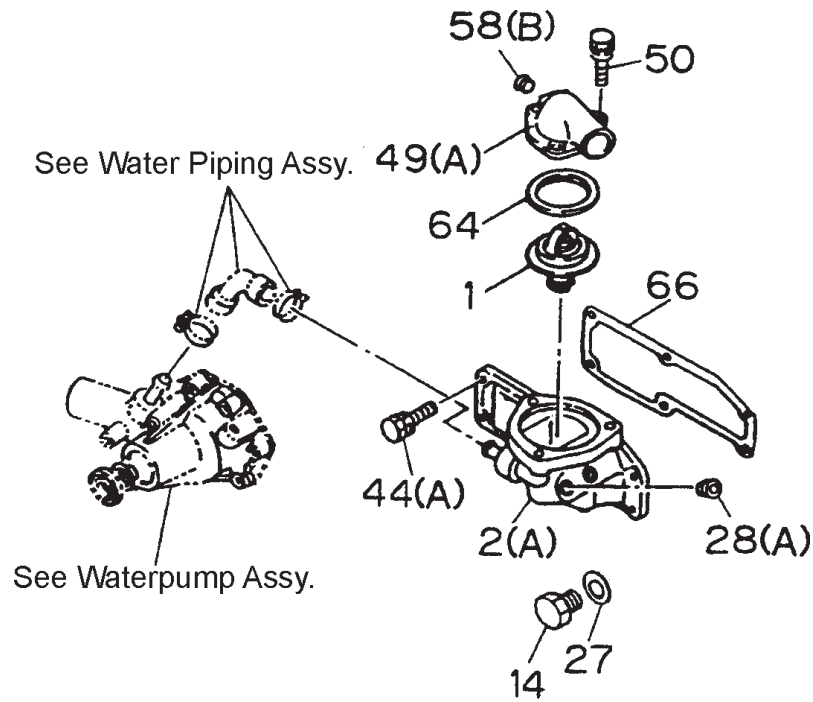

ISUZU 4BG1 — THERMOSTAT AND HOUSING ASSY.

THERMOSTAT AND HOUSING ASSY.

<u>NO.</u>	<u>PART NO.</u>	<u>PART NAME</u>	<u>QTY.</u>	<u>REMARKS</u>
1	5137700301	THERMOSTAT	1	
2	8944033142	HOUSING	1	
14	9096610050	SWITCH	1	
27	9095713160	GASKET	1	REPLACES 9095714160
28	5096050050	HEATER PLUG	1	
44	0501410250	BOLT	4	M10X25 W/LOCK AND PLAIN WASHER
44	0501410300	BOLT	2	M10X30 W/LOCK AND PLAIN WASHER
49	8944017531	WATER OUTLET PIPE	1	
50	0500408250	BOLT	3	
58	5096050050	WATER OUTLET PLUG	1	
64	8941760310	GASKET	1	
66	8943706730	GASKET	1	

ISUZU 4BG1 — ENGINE WATER PIPING ASSY.

ENGINE WATER PIPING ASSY.

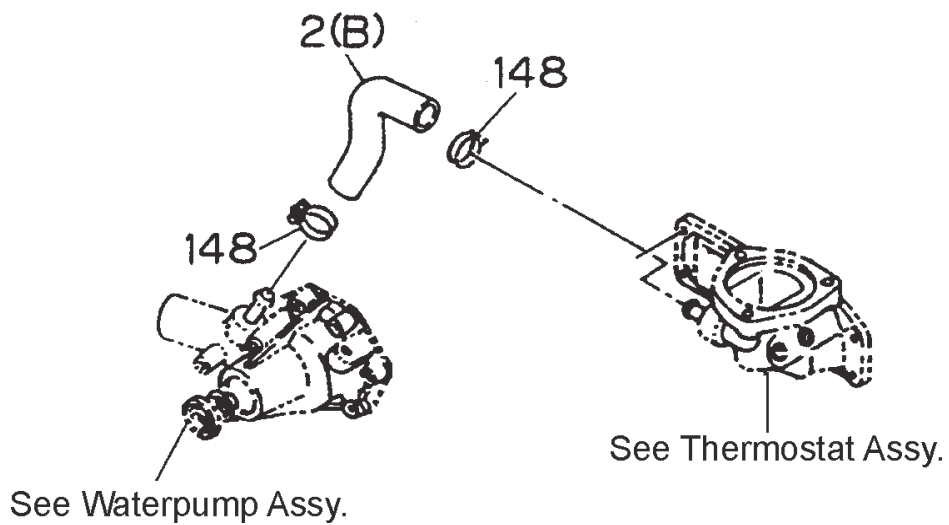

ISUZU 4BG1 — ENGINE WATER PIPING ASSY.

ENGINE WATER PIPING ASSY.

<u>NO.</u>	<u>PART NO.</u>	<u>PART NAME</u>	<u>QTY.</u>	<u>REMARKS</u>
2	8941324900	HOSE	1	
148	9099153151	CLIP	2	

ISUZU 4BG1 — FAN AND FAN BELT ASSY.

FAN AND FAN BELT ASSY.

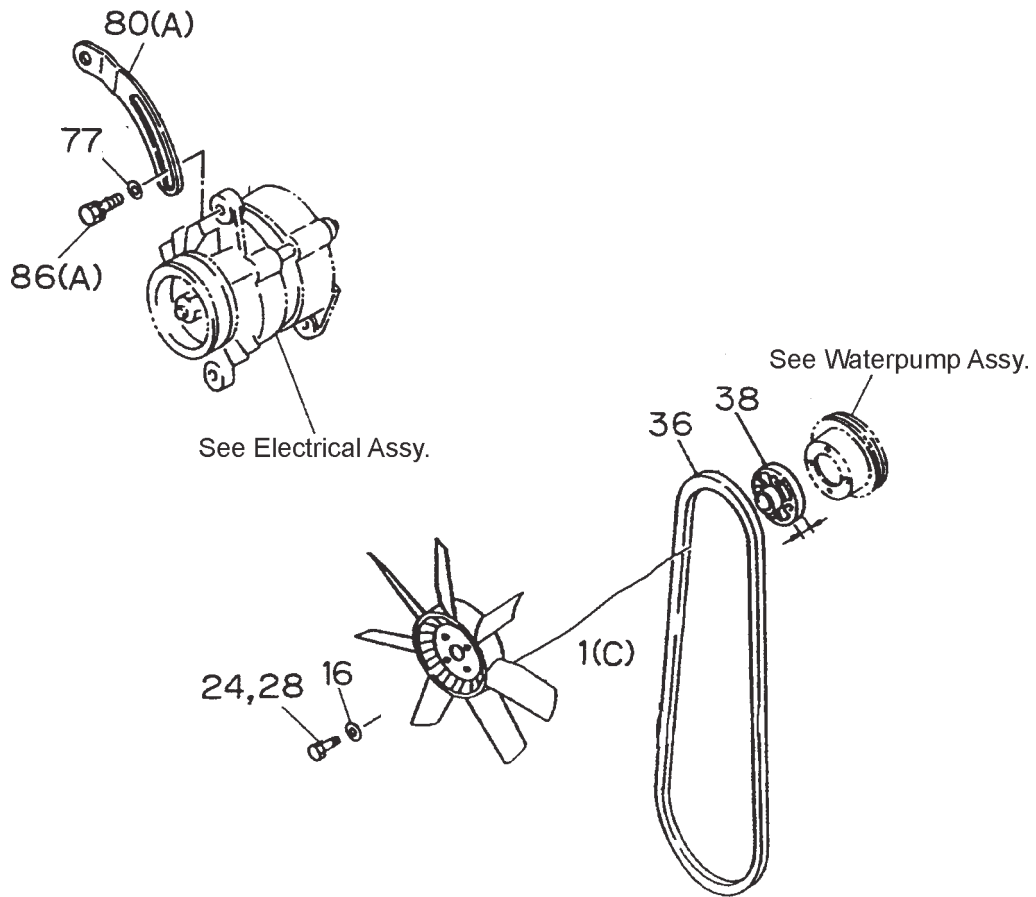

ISUZU 4BG1 — FAN AND FAN BELT ASSY.

FAN AND FAN BELT ASSY.

<u>NO.</u>	<u>PART NO.</u>	<u>PART NAME</u>	<u>QTY.</u>	<u>REMARKS</u>
1	8970699020	COOLING FAN	1	
16	9098516490	WASHER	4	
24	8942059861	BOLT	4	M8X65
36	8970208220	BELT	1	REPLACES 5136711320
38	1136420250	SPACER	1	
77	9091647080	WASHER	1	
80	5136740320	ADJUSTING PLATE	1	
86A	0500408220	BOLT	1	
86B	0501410300	BOLT	1	

ISUZU 4BG1 — FUEL INJECTION ASSY.

FUEL INJECTION ASSY.

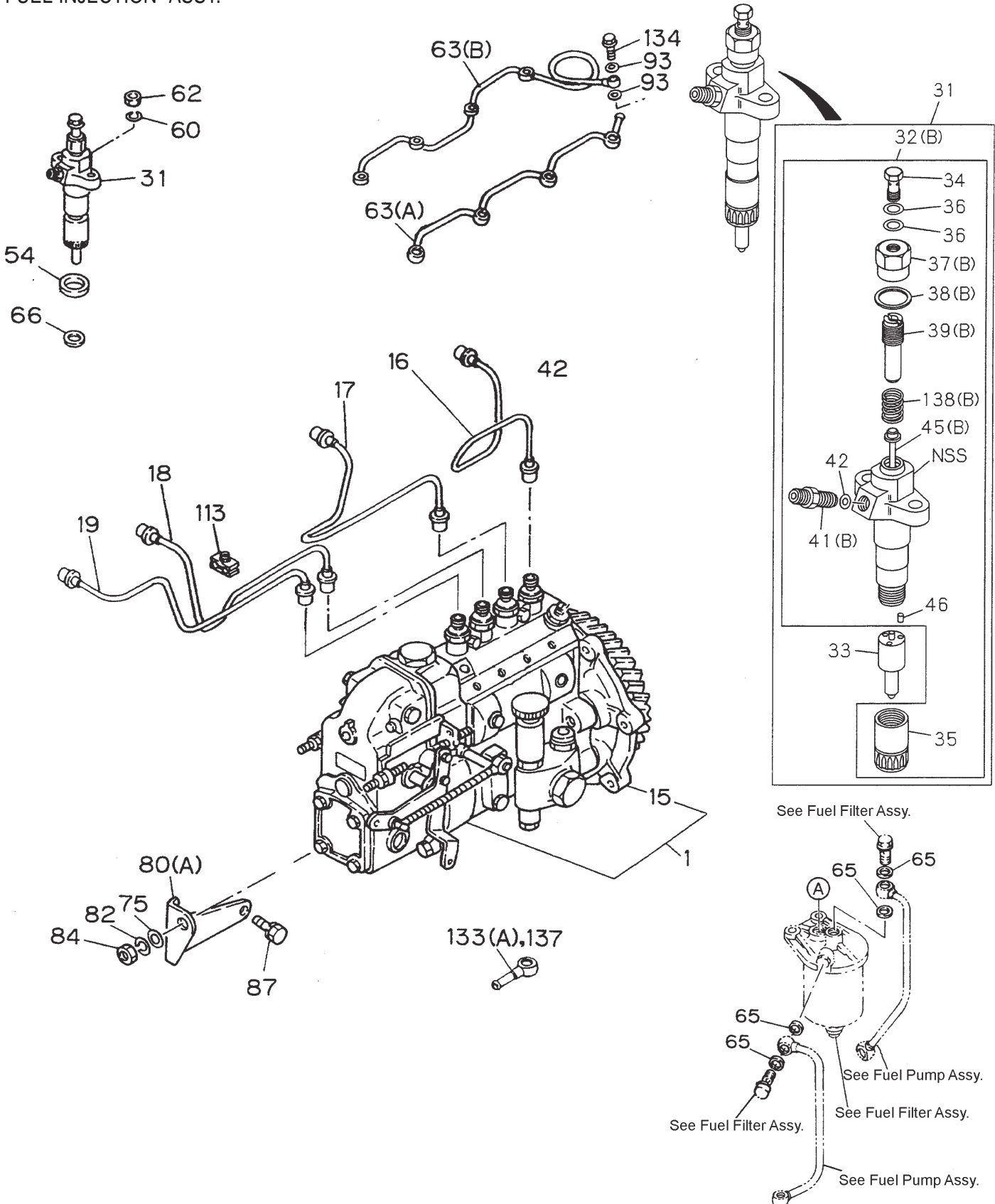

ISUZU 4BG1 — FUEL INJECTION ASSY.

FUEL INJECTION ASSY.

<u>NO.</u>	<u>PART NO.</u>	<u>PART NAME</u>	<u>QTY.</u>	<u>REMARKS</u>
1*	8971612100	INJECTION PUMP ASSY.	1	INCLUDES ITEM W/*
15	8971230631	COUPLING ASSY.	1	
16	8970314671	INJ. PIPE, NO. 1	1	
17	8970314681	INJ. PIPE, NO. 2	1	
18	8970314691	INJ. PIPE, NO. 3	1	
19	8970314701	INJ. PIPE, NO. 4	1	
31	1153002912	NOZZLE ASSY.	4	
32#	8970161471	NOZZLE HOLDER ASSY.	4	INCL. ITEMS W/%
33#	5153110270	NOZZLE ASSY.	4	INCL. ITEMS W/#
34%#	1153390090	BOLT	4	
35%#	1153320170	NUT	4	
36%#	1153390100	GASKET	8	
37%#	5153320060	NUT	4	
38%#	5153390600	GASKET	4	
39%#	8941695030	SCREW	4	
41%#	8943203080	CONNECTOR	4	
42%#	5513390030	GASKET	4	
45%#	8941695020	PUSH ROD	4	
46%#	9153470030	NOZZLE PIN	8	
54	9153390510	COVER	4	
62	0911501080	NUT	8	
63	5154110420	LEAK OFF PIPE	1	REPLACES 8970209371
65	9095720140	GASKET	4	
66	5153150030	GASKET	4	
75	9091605100	WASHER	1	
80	5197510150	BRACKET	1	
82	9091505100	WASHER	1	
84	9091105100	NUT	1	
87	0500410250	BOLT	2	
93	9095714080	GASKET	2	
113	5154190131	CLIP	3	
133	5154112231	NOZZLE PIPE	1	
133	8970209350	NOZZLE PIPE	1	
134	1096750371	BOLT	1	
138%#	5153430050	SPRING	4	

ISUZU 4BG1 — FUEL FILTER AND BRACKET ASSY.

FUEL FILTER AND BRACKET ASSY.

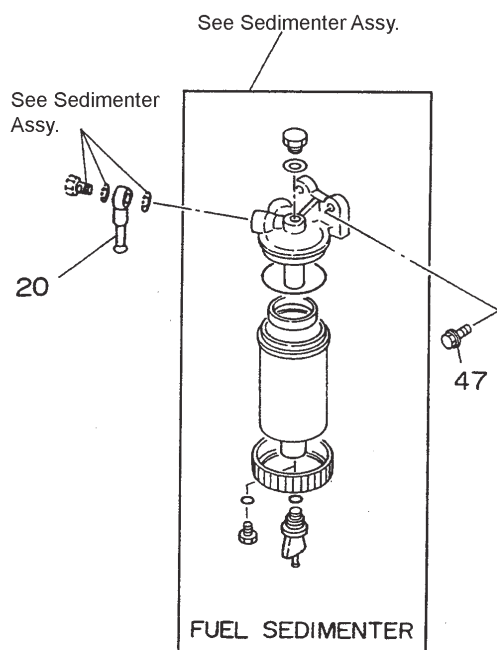
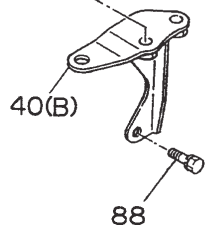
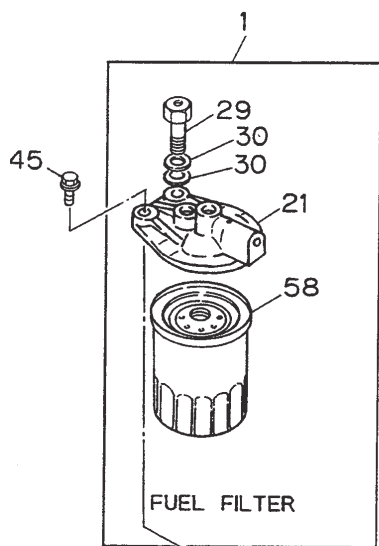
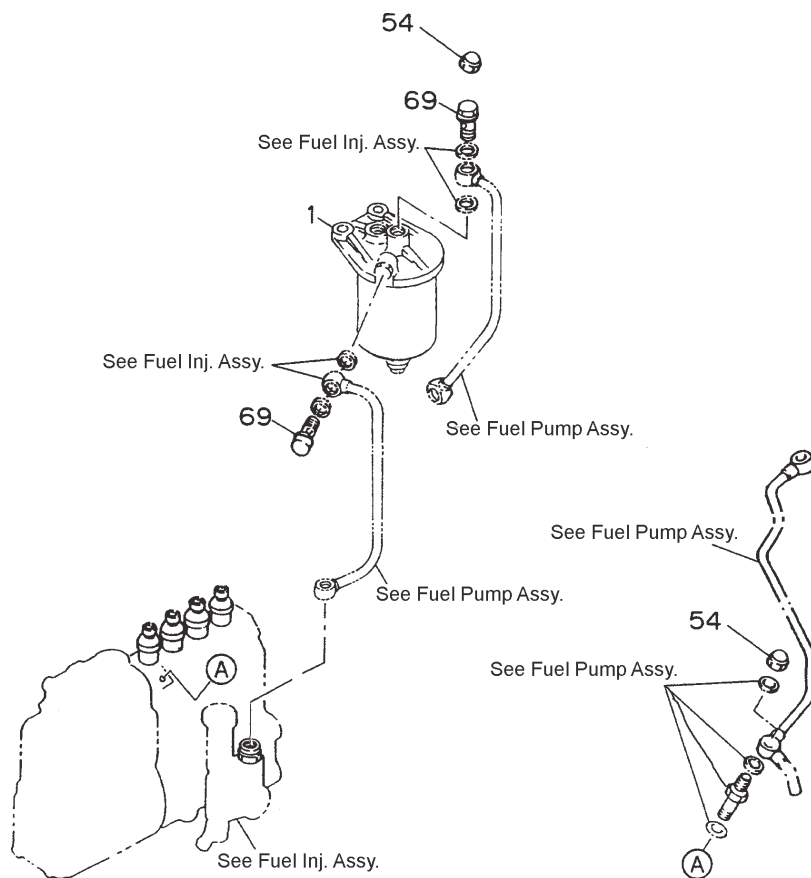

ISUZU 4BG1 — FUEL FILTER AND BRACKET ASSY.

FUEL FILTER AND BRACKET ASSY.

<u>NO.</u>	<u>PART NO.</u>	<u>PART NAME</u>	<u>QTY.</u>	<u>REMARKS</u>
1*	1132007011	FUEL FILTER ASSY.	1	REPLACES 8944537371 AND 8941517451 INCLUDES ITEMS W/*
20	5154112231	EYE JOINT	1	
21*	1132120870	COVER	1	REPLACES 5132120751
29*	1132600470	OVERFLOW VALVE	1	REPLACES 9132600562
30*	1096300850	GASKET	2	REPLACES 9095720140
40	5197550010	BRACKET	1	
45	0501410350	BOLT	2	
47	0501408250	BOLT	2	
54	1094680021	NUT	1	
58*	X132400240	ELEMENT	1	REPLACES 8944147963, 1132400791
69	9099063251	BOLT	2	
88	0500410200	BOLT	2	

ISUZU 4BG1 — FUEL PUMP AND PIPE ASSY.

FUEL PUMP AND PIPE ASSY.

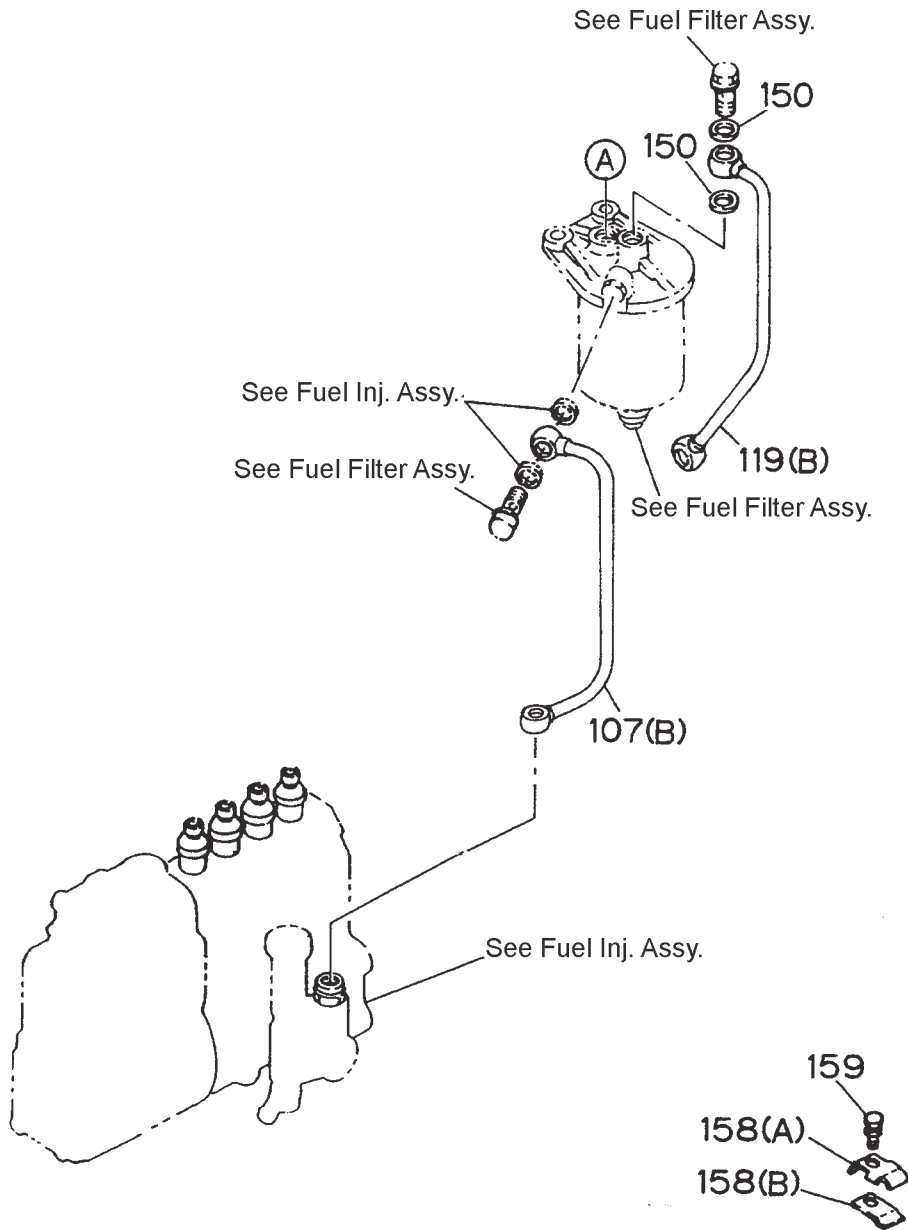

ISUZU 4BG1 — FUEL PUMP AND PIPE ASSY.

FUEL PUMP AND PIPE ASSY.

<u>NO.</u>	<u>PART NO.</u>	<u>PART NAME</u>	<u>QTY.</u>	<u>REMARKS</u>
107	5154114570	PIPE	1	REPLACES 8970209330
119	9154127311	PIPE	1	REPLACES 8970209340
150	9095720140	GASKET	2	
158A	5154190040	CLIP	1	
158B	5154190051	CLIP	1	
159	0501406160	BOLT	1	

ISUZU 4BG1 — OIL COOLER AND OIL FILTER ASSY.

OIL COOLER AND OIL FILTER ASSY.

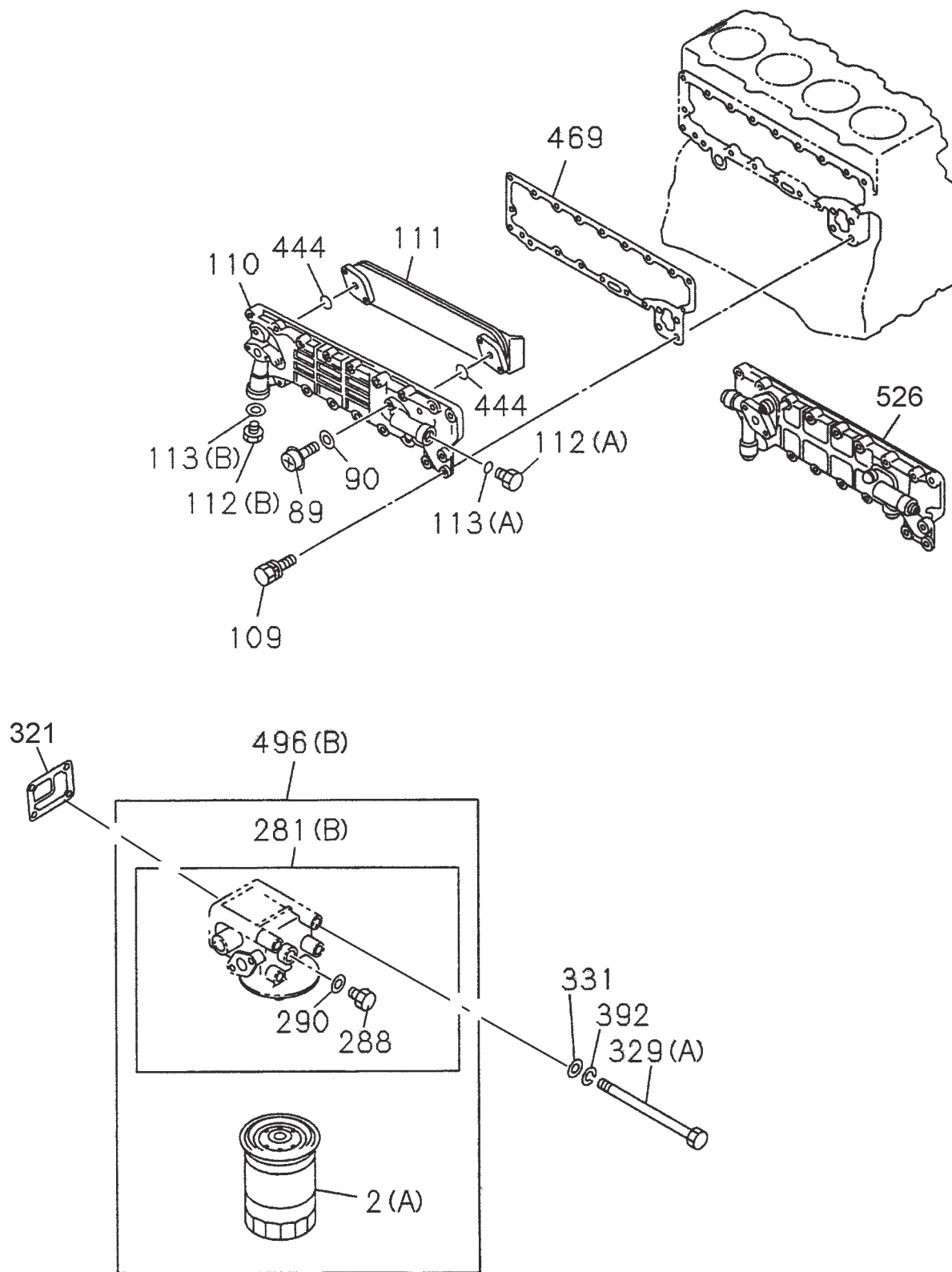

ISUZU 4BG1 — OIL COOLER AND OIL FILTER ASSY.

OIL COOLER AND OIL FILTER ASSY.

<u>NO.</u>	<u>PART NO.</u>	<u>PART NAME</u>	<u>QTY.</u>	<u>REMARKS</u>
2 A\$	8943212191	ELEMENT, OIL FILTER	1	
89	5112890090	BOLT, ELEMENT TO CASE	1	
90	1217290430	GASKET, BOLT, OIL COOLER	1	
109	0500408250	BOLT, M8X25	11	W/LOCK WASHER
109	0500408450	BOLT, M8 X45	8	W/LOCK WASHER
109	0500408200	BOLT, M8X20	2	W/LOCK WASHER
109	8942058961	BOLT, M8X65	1	
110	8944496450	BODY; CASE, OIL COOLER	1	
111	8970320250	CORE; OIL COOLER	1	
112 A	8971281500	PLUG; OIL COOLER CASE	1	
112 B	5112880020	PLUG; OIL COOLER CASE	1	
113 A	8944706680	GASKET; PLUG; OIL COOLER CASE	1	
113 B	9095716200	GASKET; PLUG; OIL COOLER CASE	1	
281 B\$	8970261351	COVER, OIL FILTER	1	INCLUDES ITEMS W/*
288*\$	9132630100	PLUG; OIL DRAIN	1	
290*\$	9099211930	GASKET; PLUG OIL DRAIN	1	
321	8943706700	GASKET; OIL FILTER TO C/BL	1	
329 A	5090000071	BOLT, M10X135	4	
331	9091605100	WASHER	4	
392	9091505100	LOCK WASHER	4	
444	5112820110	GASKET;ELEMENT TO BODY	1	
469	8970196530	GASKET; OIL COOLER TO C/BL	1	
484	9099168190	CLIP	2	
496 B	8970209271	FILTER ASSY.	1	INCLUDES ITEMS W/\$
526	5112800111	COVER; WATER DUCT	1	

ISUZU 4BG1 — OIL PUMP AND OIL STRAINER ASSY.

OIL PUMP AND OIL STRAINER ASSY.

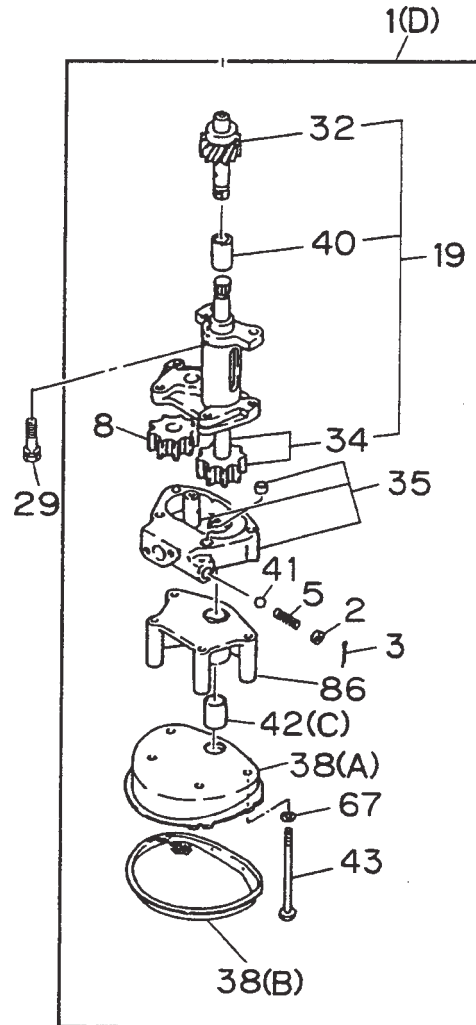

ISUZU 4BG1 — OIL PUMP AND OIL STRAINER ASSY.

OIL PUMP AND OIL STRAINER ASSY.

<u>NO.</u>	<u>PART NO.</u>	<u>PART NAME</u>	<u>QTY.</u>	<u>REMARKS</u>
1	5131001373	OIL PUMP ASSY.	1	INCLUDES ITEMS W/\$
2\$	5131650040	SPRING SEAT	1	
3\$	9081040300	PIN	1	
5\$	5095800980	COIL SPRING	1	
8\$	5131250020	GEAR	1	
19\$	5878102022	GEAR SET	1	INCLUDES ITEMS W/#
29	0500410250	BOLT	2	
32\$#	1131280180	PINION	1	
34\$#	5131210140	SHAFT	1	
35\$	5131130351	COVER	1	
38A\$	5131410171	CASE	1	
38B\$	5131410180	CASE	1	
40\$#	1131230160	COUPLING	1	
41\$	5098430030	VALVE BALL	1	
42\$	5131190060	STRAINER	1	
43\$	0108058000	BOLT	4	
67\$	9091505080	WASHER	4	
86\$	1131190010	SPACER	1	

ISUZU 4BG1 — OIL AND VACUUM PIPING ASSY.

OIL AND VACUUM PIPING ASSY.

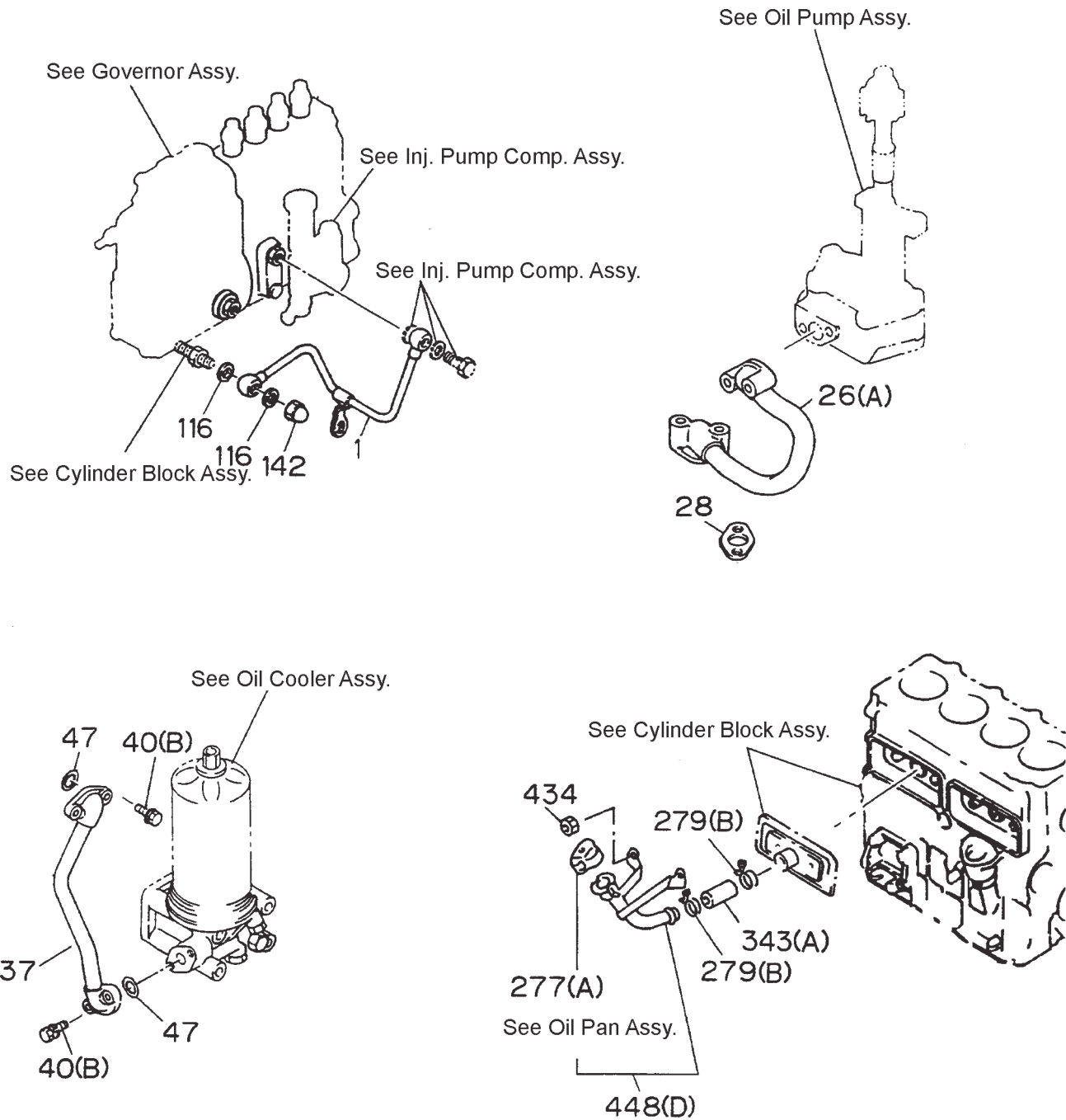

ISUZU 4BG1 — OIL AND VACUUM PIPING ASSY.

OIL AND VACUUM PIPING ASSY.

<u>NO.</u>	<u>PART NO.</u>	<u>PART NAME</u>	<u>QTY.</u>	<u>REMARKS</u>
1	8971242340	PIPE	1	
26	8941753012	PIPE	1	
28	9099211880	GASKET	2	
37	5133112561	PIPE	1	
40	0501408450	BOLT	4	M8X45 W/LOCK AND PLAIN WASHER
40	0500408350	BOLT	2	M8X35 W/LOCK WASHER
40	0500408320	BOLT	2	M8X32 W/LOCK WASHER
47	1096234620	GASKET	2	
116	9095720100	GASKET	2	
142	9098440220	NUT	1	
279	8941625680	CLIP	2	
343	1093600430	HOSE	1	
434	0911501080	NUT	1	
448	8941405812	FILLER	1	

ISUZU 4BG1 — ELECTRICAL CONTROL ASSY.

ELECTRICAL CONTROL ASSY.

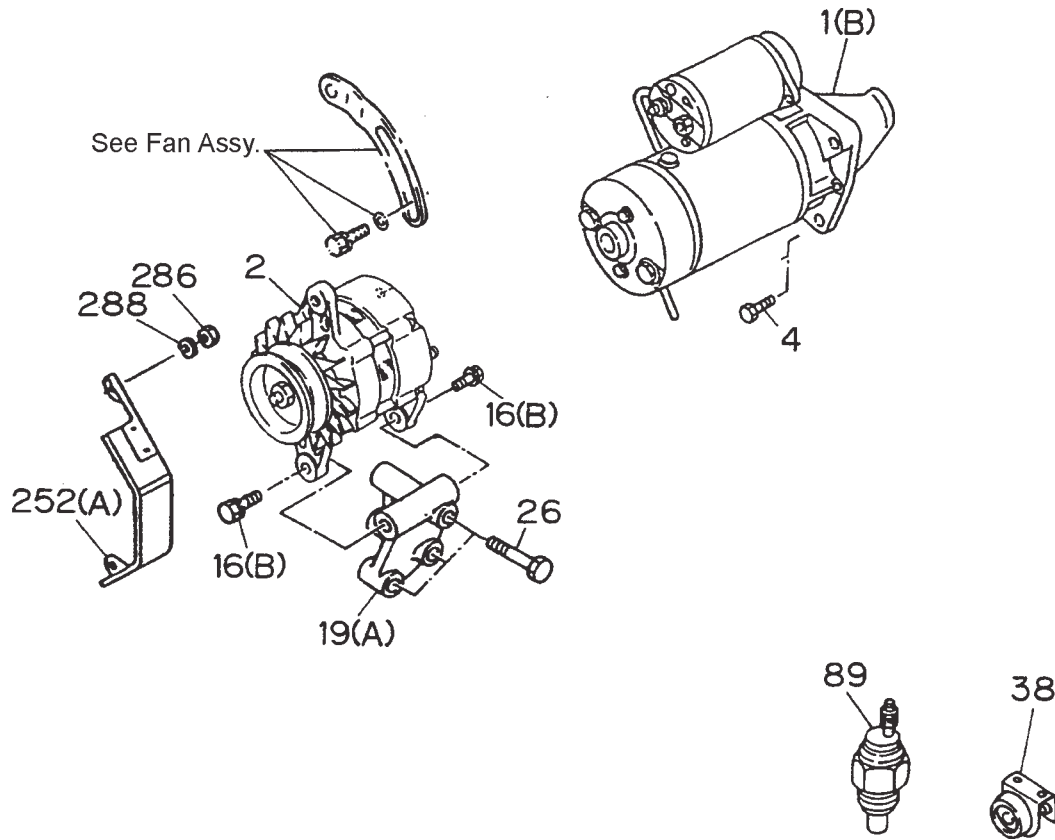

ISUZU 4BG1 — ELECTRICAL CONTROL ASSY.

ELECTRICAL CONTROL ASSY.

<u>NO.</u>	<u>PART NO.</u>	<u>PART NAME</u>	<u>QTY.</u>	<u>REMARKS</u>
1	1811001911	STARTER ASSY.	1	24V 4.5KW
2	8971433290	GENERATOR ASSY.	1	24V 30A
4	0500512280	BOLT	1	M12X28
4	0287812350	BOLT	2	M12X35
16	0501408350	BOLT	2	M8X35 W/LOCK AND PLAIN WASHER
19	5197110620	BRACKET	1	
26	050041000	BOLT	1	M10X100
26	0500410450	BOLT	1	M10X45 W/LOCKWASHER
26	5090300101	BOLT	1	M10X75 W/LOCKWASHER
38	9825300460	RESISTOR		
89	8970299880	SWITCH	1	
252	8943717120	COVER	1	
286	0911502080	NUT	1	
288	9091606080	PLAIN WASHER	1	

BATTERY RELAY ASSY.

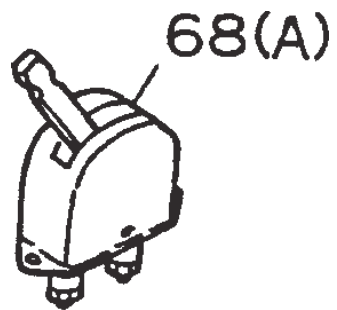

ISUZU 4BG1 — BATTERY RELAY ASSY.

BATTERY RELAY ASSY.

<u>NO.</u>	<u>PART NO.</u>	<u>PART NAME</u>	<u>QTY.</u>	<u>REMARKS</u>
68	1823200010	BATTERY RELAY	1	

ISUZU 4BG1 — STARTER COMP. ASSY.

STARTER COMP. ASSY.

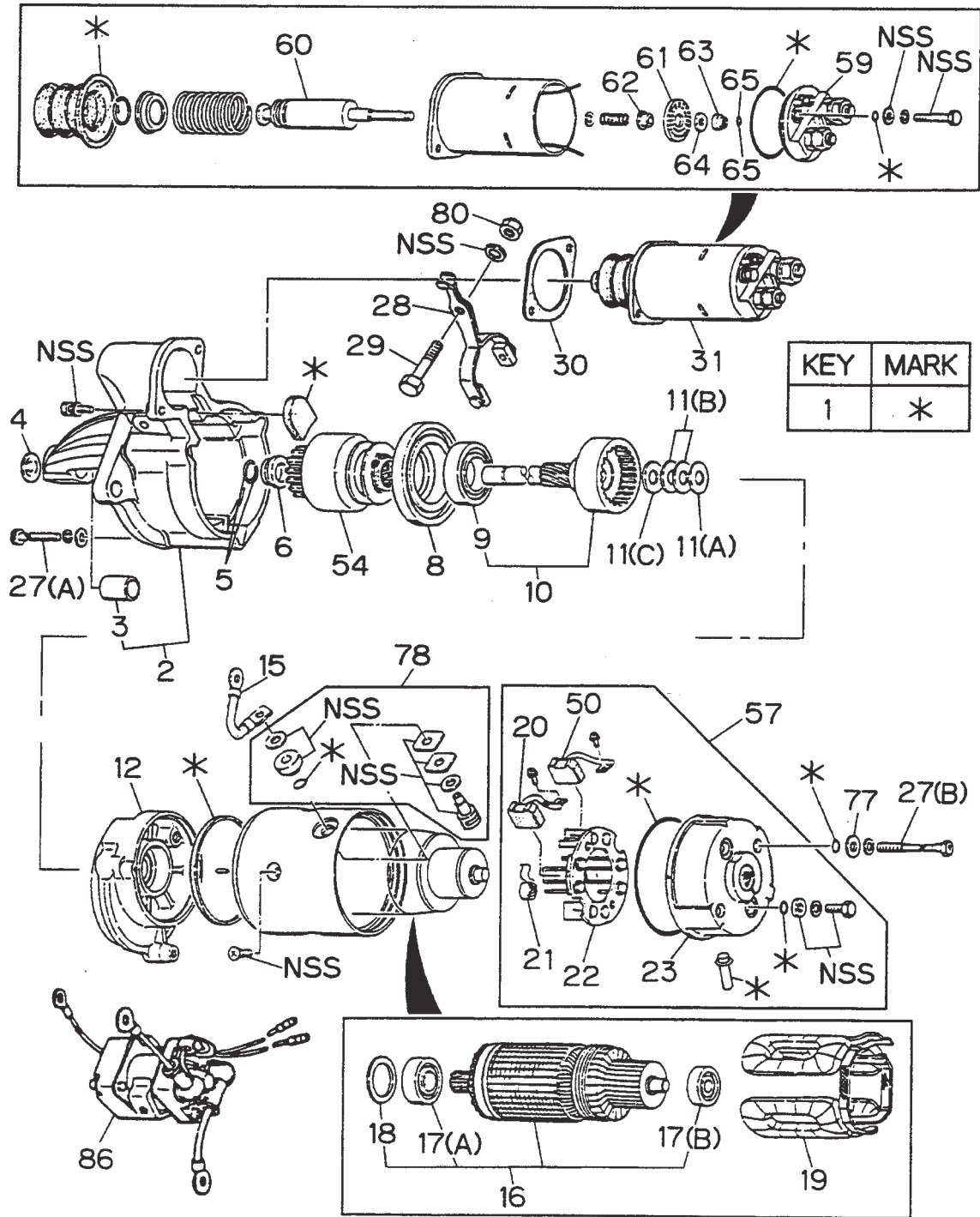

ISUZU 4BG1 — STARTER COMP. ASSY.

STARTER COMP. ASSY.

<u>NO.</u>	<u>PART NO.</u>	<u>PART NAME</u>	<u>QTY.</u>	<u>REMARKS</u>
1	1811293940	SEAL KIT	1	INCLUDES ITEMS W/* SHOWN IN PICTURE
2	1811230250	CASE	1	INCLUDES ITEMS W/#
3#	1811293970	METAL	1	
4	5811291420	COVER	1	
5	5811291440	CLIP	1	
6	5811291450	STOPPER	1	
8	1811130260	BRACKET	1	
9%	1811293860	BEARING	1	
10	1811230240	SHAFT	1	INCL. ITEM W%
11A	5811291580	WASHER	1	
11B	5811291590	WASHER	2	
11C	5811291600	WASHER	1	
12	1811130730	BRACKET	1	
15	1811160440	WIRE	1	
16	1811210370	ARMATURE	1	INCLUDES ITEMS W/\$
17A\$	5811291550	BEARING	1	
17B\$	1811291960	BEARING	1	
18\$	5811291560	WASHER	1	
19	1811293960	COIL	1	
20@	1811160420	BRUSH	1	
21@	1811170140	SPRING	1	
22@	1811180360	HOLDER	1	
23@	1811150620	COVER	1	
27A	1811293870	BOLT	3	
27B	5811292140	BOLT	2	
28	1811270310	LEVER	1	
29	1811291850	PIN	1	
30	5811291470	PLATE	1	
31	5811510360	SWITCH	1	
50@	1811160430	BRUSH	1	
54	5811220160	CLUTCH	1	
57	1811150610	COVER ASSY.	1	INCLUDES ITEMS W/@
59	5811291500	TERMINAL	1	
61	5811291480	CONTACT	1	
62	9821161400	BUSHING	1	
63	5811180190	HOLDER	1	
64	9821161420	WASHER	1	
65	5811291490	RING	2	
77	1811291140	WASHER	2	
78	1811293840	TERMINAL	1	
80	1811291840	NUT	1	
86	1825530370	RELAY	1	

ISUZU 4BG1 — INJECTION PUMP COMP. ASSY. (CONT.)

INJECTION PUMP COMP. ASSY. (CONT.)

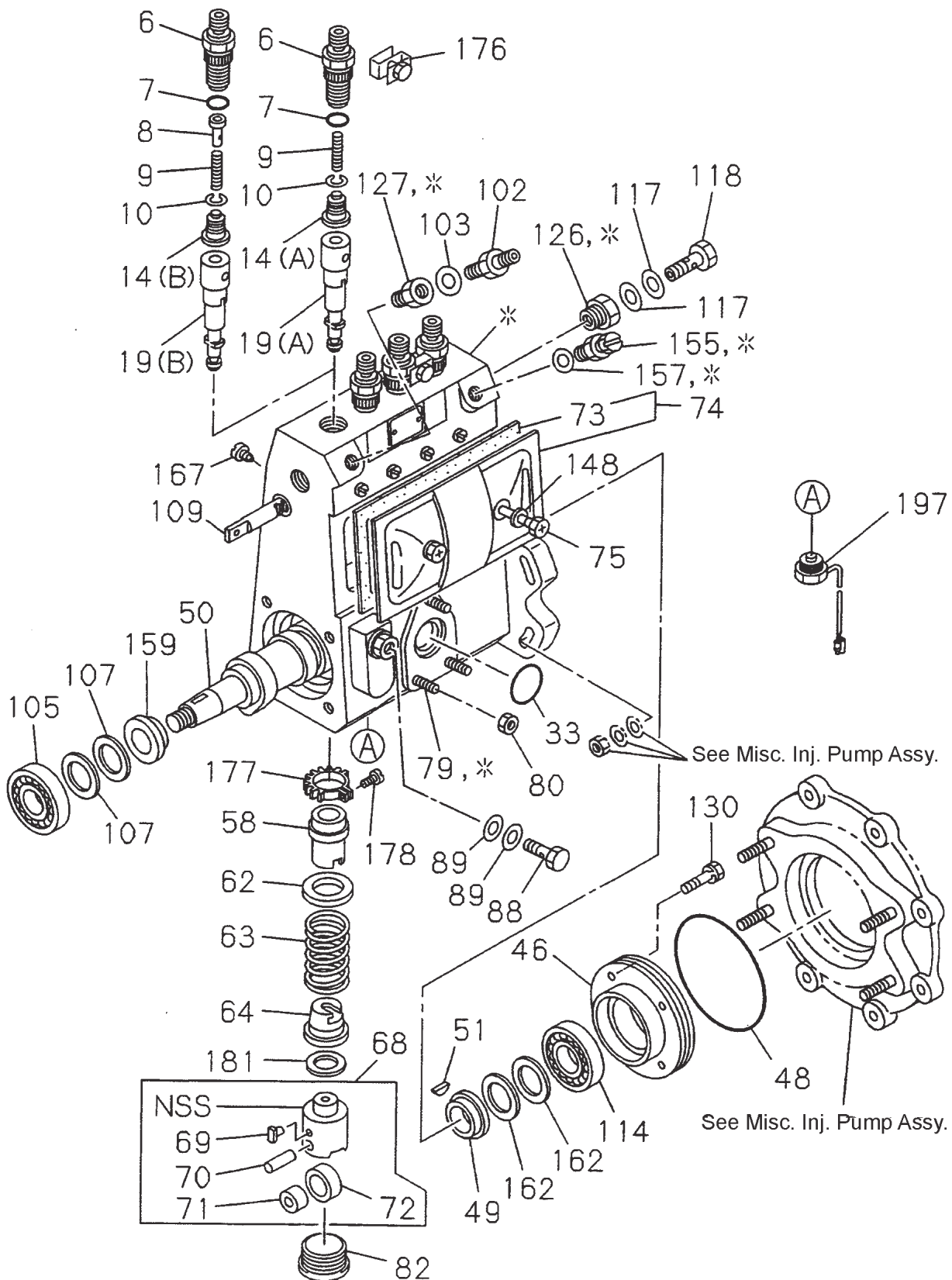

ISUZU 4BG1 — INJECTION PUMP COMP. ASSY. (CONT.)

INJECTION PUMP COMP. ASSY. (CONT.)

<u>NO.</u>	<u>PART NO.</u>	<u>PART NAME</u>	<u>QTY.</u>	<u>REMARKS</u>
1	5156110590	HOUSING	1	
6	5156440170	HOLDER	4	
7	1096230520	GASKET	4	
8	5156290450	STOPPER	4	
9	5156430010	SPRING	4	
10	1156490010	GASKET	4	
14	5156410030	VALVE	4	
19	8943771540	PLUNGER	4	
33	1096230130	GASKET	1	
46	1156192430	COVER	1	
48	5156191560	GASKET	1	
49	9812250470	RING	1	
50	5156210190	CAMSHAFT	1	
51	5156190490	KEY	1	
58	9812250580	SLEEVE	4	
62	9812350150	SEAT	4	
63	5156430090	SPRING	4	
64	9812350210	SEAT	4	
68	9812212230	TAPPET	4	INCL. ITEMS W/*
69	5156190410	GUIDE	4	
70*	9812222200	PIN	4	
71*	1156290010	BUSHING	4	
72*	1156220030	ROLLER	4	
73	8943865960	GASKET	1	
74	8941711090	COVER	1	
75	1156190030	SCREW	2	
79	9812151150	STUD	3	
80	8941711100	NUT	3	
82	5156191360	PLUG	4	
88	9019006140	BOLT	4	
89	9095720100	GASKET	2	
102	1132600011	VALVE	1	
103	1157590010	GASKET	1	
105	9000906770	BEARING	1	NSK
105	5098000380	BEARING	1	NTN
107	5156290150	SHIM	1	T=0.10
107	5156290160	SHIM	1	T=0.12
107	5156290170	SHIM	1	T=0.14
107	5156290180	SHIM	1	T=0.16
107	5156290190	SHIM	1	T=0.18
107	5156290200	SHIM	1	T=0.50
107	5156290380	SHIM	1	T=1.00
107	9812250330	SHIM	1	T=0.30
107	5156190390	SHIM	1	T=0.70
107	5156290900	SHIM	1	T=1.40
107	1156390880	SHIM	1	T=2.40
114	9000906770	BEARING	1	NSK
114	5098000380	BEARING	1	NTN
117	1157590010	GASKET	2	
118	1156190820	BOLT	1	

ISUZU 4BG1 — INJECTION PUMP COMP. ASSY. (CONT.)

INJECTION PUMP COMP. ASSY. (CONT.)

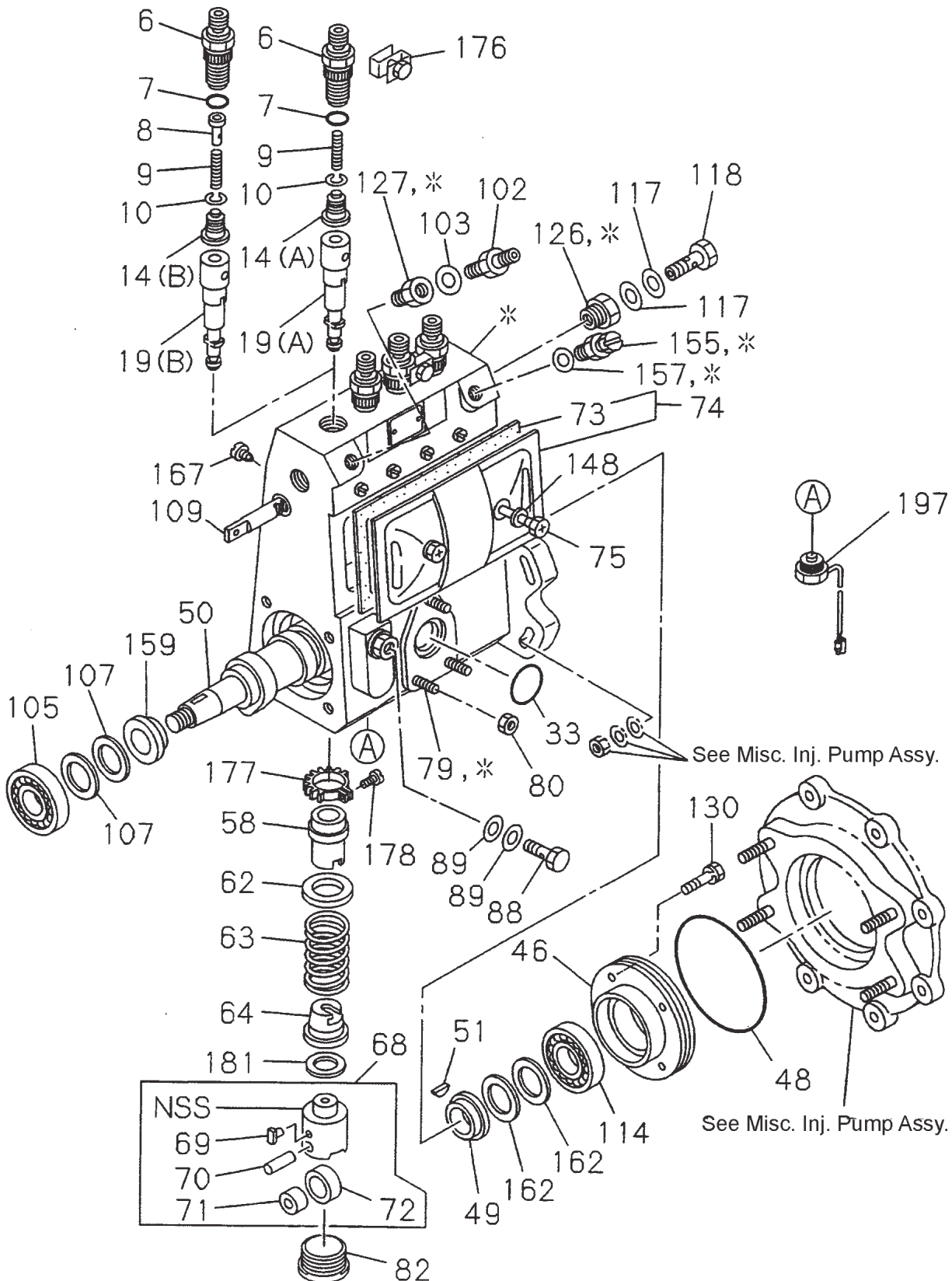

ISUZU 4BG1 — INJECTION PUMP COMP. ASSY. (CONT.)

INJECTION PUMP COMP. ASSY. (CONT.)

<u>NO.</u>	<u>PART NO.</u>	<u>PART NAME</u>	<u>QTY.</u>	<u>REMARKS</u>
126	9812350170	ADAPTER	1	
127	5156190440	ADAPTER	1	
130	9019006140	SCREW	4	
148	9812151440	GASKET	2	
155	1156190240	BOLT	1	
157	8941445880	GASKET	1	
159	9812250470	RING	1	
162	5156290150	SHIM	1	T=0.10
162	5156290160	SHIM	1	T=0.12
162	5156290170	SHIM	1	T=0.14
162	5156290180	SHIM	1	T=0.16
162	5156290190	SHIM	1	T=0.18
162	5156290200	SHIM	1	T=0.50
162	5156290380	SHIM	1	T=1.00
162	9812250330	SHIM	1	T=0.30
162	5156190390	SHIM	1	T=0.70
162	5156290900	SHIM	1	T=1.40
162	1156390880	SHIM	1	T=2.40
176	5156250010	PLATE	2	
177	9812250570	PINION	4	
178	9812350030	SCREW	4	
181	5156190340	SHIM	1	T=0.30
181	5156190350	SHIM	1	T=0.40
181	5156190360	SHIM	1	T=0.50
181	5156190010	SHIM	1	T=0.60
181	5156190020	SHIM	1	T=0.70
181	5156190030	SHIM	1	T=0.80
181	5156190040	SHIM	1	T=0.90
181	5156190050	SHIM	1	T=1.00
181	5156190070	SHIM	1	T=1.10
181	5156190080	SHIM	1	T=1.20
181	5156190090	SHIM	1	T=1.30
181	5156190100	SHIM	1	T=1.40
181	5156190110	SHIM	1	T=0.55
181	5156190120	SHIM	1	T=0.65
181	5156190130	SHIM	1	T=0.75
181	5156190150	SHIM	1	T=0.85
181	9812350420	SHIM	1	T=0.95
181	9812350430	SHIM	1	T=1.05
181	9812350440	SHIM	1	T=1.15
181	9812350450	SHIM	1	T=1.25
181	5156190250	SHIM	1	T=0.20
181	5156190260	SHIM	1	T=0.25
181	5156190270	SHIM	1	T=0.35
181	5156190370	SHIM	1	T=0.45
181	5156191060	SHIM	1	T=1.50
181	5156191070	SHIM	1	T=1.60
181	5156191080	SHIM	1	T=1.35
181	5156191090	SHIM	1	T=1.45
181	5156191100	SHIM	1	T=1.55

ISUZU 4BG1 — GOVERNOR COMP. ASSY.

GOVERNOR COMP. ASSY.

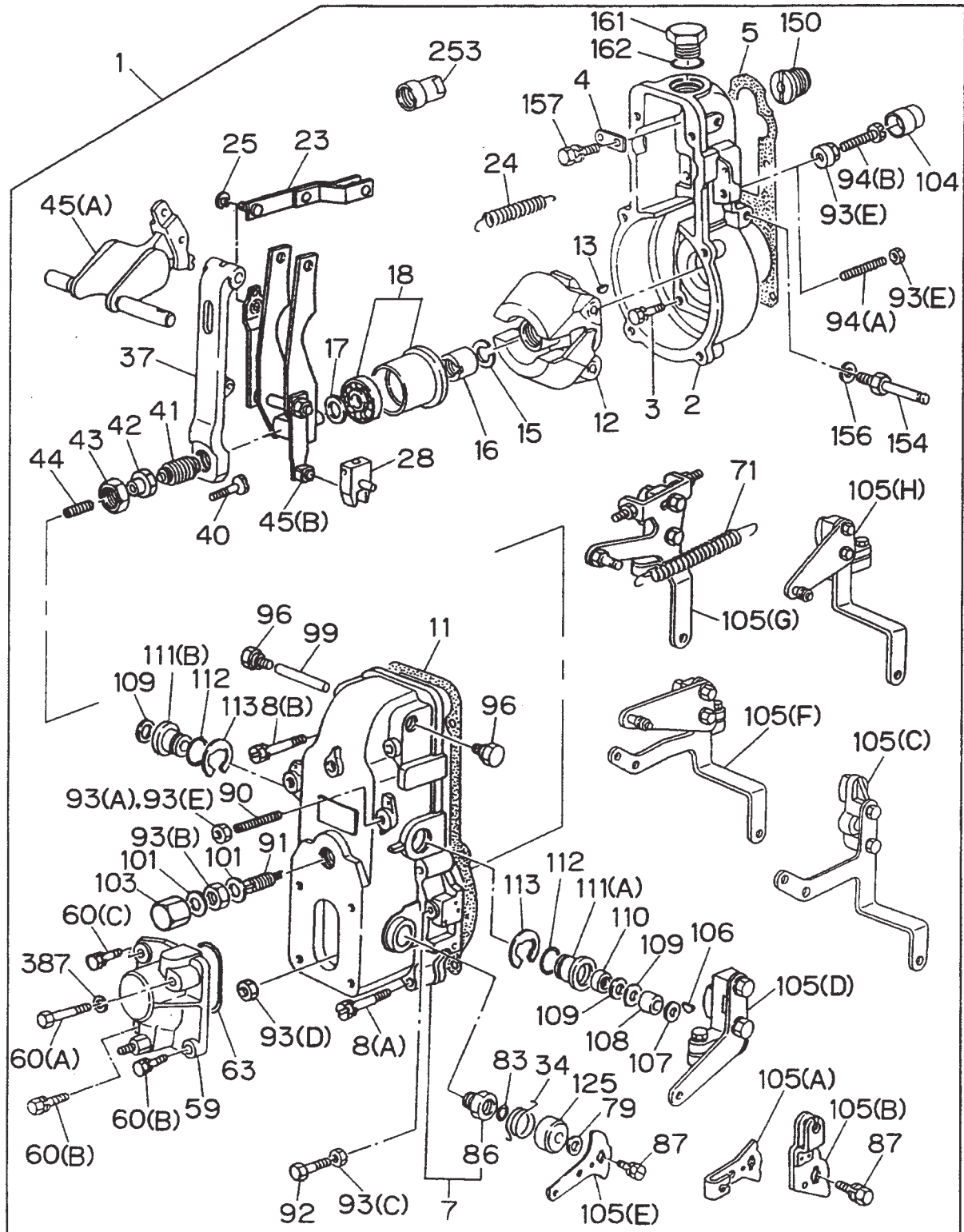

ISUZU 4BG1 — GOVERNOR COMP. ASSY.

GOVERNOR COMP. ASSY.

<u>NO.</u>	<u>PART NO.</u>	<u>PART NAME</u>	<u>QTY.</u>	<u>REMARKS</u>
1	8971621760	GOVERNOR ASSY.	1	INCLUDES. ITEMS W/#
2#	5157210040	HOUSING	1	
3#	5157290270	BOLT	6	
4#	8913253970	PLATE	1	
7#	5157210220	COVER	1	
8A#	5157290330	BOLT	4	
8B#	5157290540	BOLT	2	
11#	1157290010	GASKET	1	
12#	1157220210	FLYWEIGHT ASSY.	1	
13#	5196190490	KEY	1	
15#	5157290340	WASHER	1	
16#	9813250860	NUT	1	
17#	9813250880	SHIM	1	T=0.20
17#	9813255510	SHIM	1	T=0.30
17#	9813255520	SHIM	1	T=0.40
17#	9813255530	SHIM	1	T=1.00
17#	5157292860	SHIM	1	T=0.50
17#	5157292870	SHIM	1	T=1.50
17#	1157298910	SHIM	1	T=2.00
17#	1157298920	SHIM	1	T=3.00
17#	1157298930	SHIM	1	T=4.00
18#	5157190080	SCREW	1	
23#	1157250110	LINK	1	
24#	9813222350	SPRING	1	
25#	9091854040	RING	1	
28#	5157250420	LEVER	1	
34#	1157232120	SPRING	1	
37#	5157250170	LEVER ASSY.	1	
40#	9813251820	SCREW	1	
41#	1157231860	SPRING CAPSULE	1	
43#	9008130230	NUT	1	
45A#	1157256680	LEVER ASSY.	1	
45B#	5157250330	LEVER ASSY.	1	
59#	5157210210	COVER	1	
60B#	5157290630	BOLT	1	
60C#	9019006160	BOLT	1	
63#	9813919070	GASKET	1	
71#	5157230880	SPRING	1	
79#	1157292940	SHIM	1	T=0.20
79#	1157292950	SHIM	1	T=0.25
79#	1157292960	SHIM	1	T=0.30
79#	1157292970	SHIM	1	T=0.35
79#	1157292980	SHIM	1	T=0.40
79#	1157292990	SHIM	1	T=0.50
83#	9813919060	SEAL	1	
86#	9813254290	BUSHING	1	
87#	9019006160	BOLT	1	
90#	9813251770	SCREW	1	
91#	1157230730	SPRING CAPSULE	1	

ISUZU 4BG1 — GOVERNOR COMP. ASSY. (CONT.)

GOVERNOR COMP. ASSY. (CONT.)

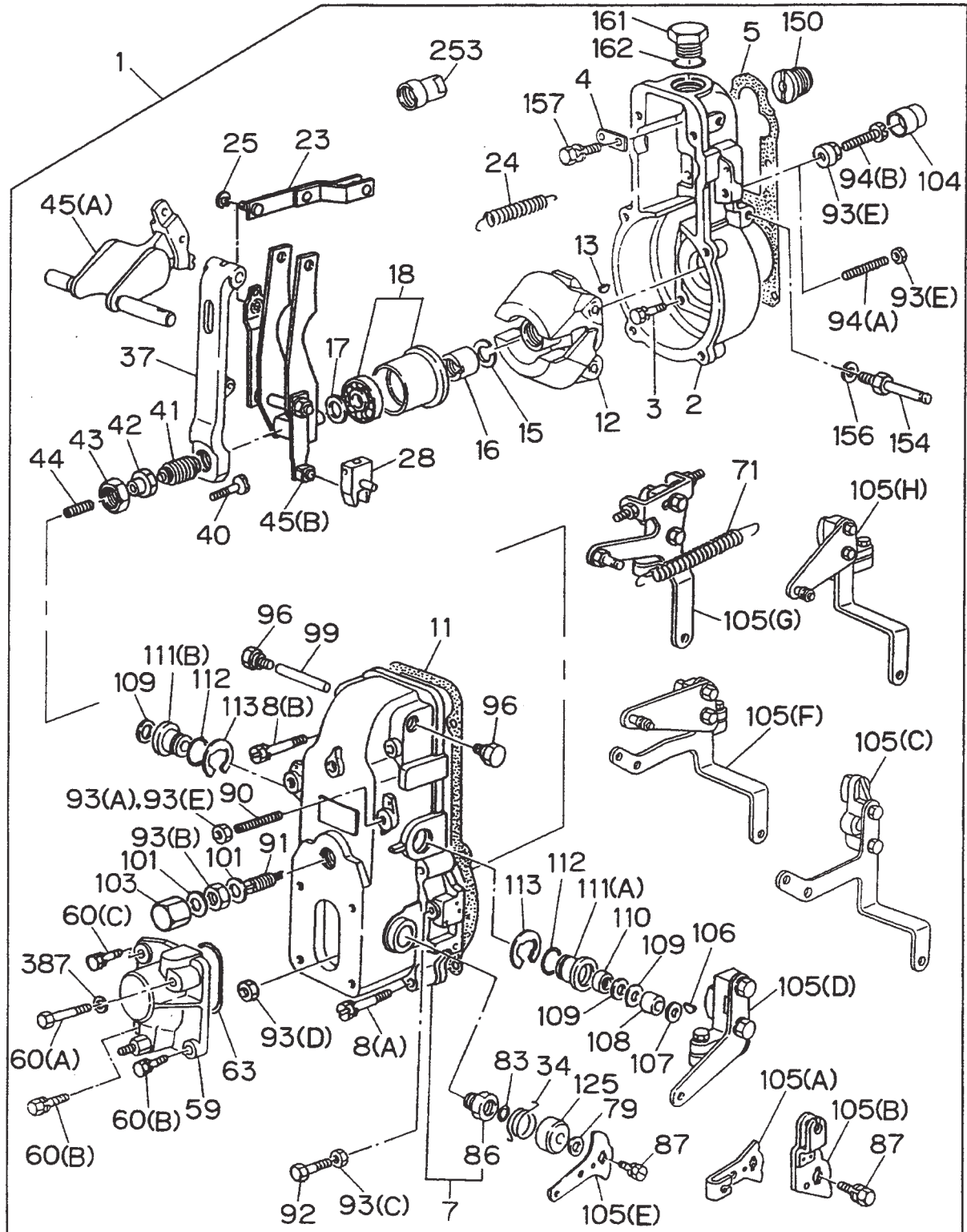

ISUZU 4BG1 — GOVERNOR COMP. ASSY. (CONT.)

GOVERNOR COMP. ASSY. (CONT.)

<u>NO.</u>	<u>PART NO.</u>	<u>PART NAME</u>	<u>QTY.</u>	<u>REMARKS</u>
93B#	1157296890	NUT	1	
93D#	9813261120	NUT	1	
93E#	9844100270	NUT	2	
94#	5157291230	SCREW	1	
96#	5157290530	PLUG	2	
99#	9813250620	PIN	1	
101#	8941445880	GASKET	2	
103#	1157290920	NUT	1	
105A#	1157250810	LEVER	1	
105D#	8943444370	LEVER	1	
105D#	8943444380	LEVER	1	
105F#	8970874410	LEVER	1	
106#	9813250300	KEY	1	
107#	9813254880	WASHER	1	
108#	1157293010	COLLAR	1	
109#	1157290990	SHIM	1	
109#	9813250970	SHIM	1	
110#	1157290980	SEAL	1	
111#	8970242390	BUSHING	2	
112#	9813212050	GASKET	2	
113#	9091854150	RING	2	
125#	9813252100	CAP	1	
150#	9813150650	ADAPTER	1	
154#	5157291120	BOLT	1	
156#	1835794920	WASHER	1	
157#	9019008180	BOLT	1	
161#	1157290380	PLUG	1	
162#	1157290150	WASHER	1	

ISUZU 4BG1 — FEED PUMP ASSY.

FEED PUMP ASSY.

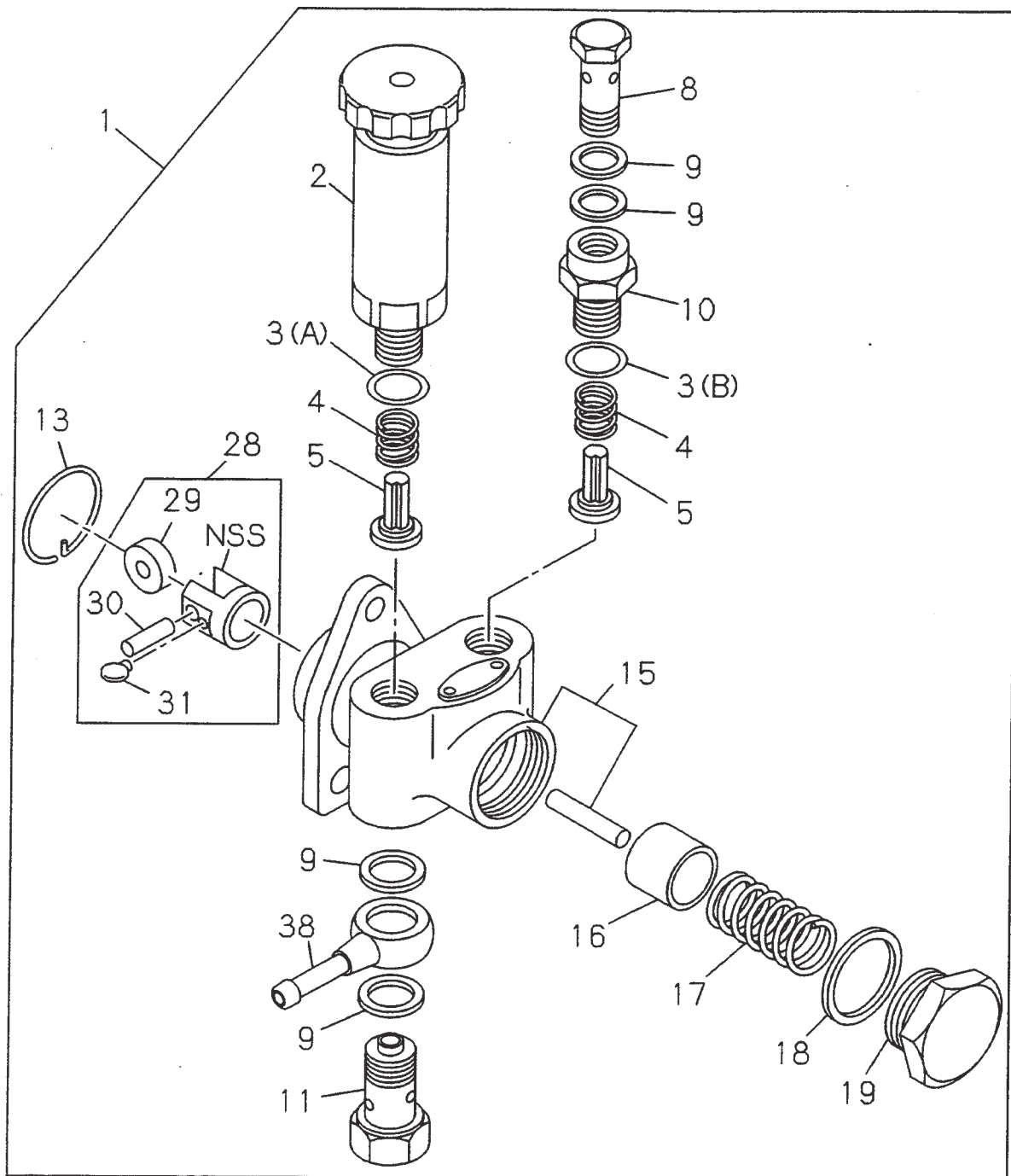

ISUZU 4BG1 — FEED PUMP ASSY.

FEED PUMP ASSY.

<u>NO.</u>	<u>PART NO.</u>	<u>PART NAME</u>	<u>QTY.</u>	<u>REMARKS</u>
1	8971219100	PUMP ASSY.	1	INCLUDES ITEMS W/*
2*	1157610060	PUMP	1	
3*	1196230160	GASKET	1	
4*	9813517020	SPRING	2	
5*	1157550020	VALVE	2	
8*	1156190820	BOLT	1	
9*	1157590010	GASKET	4	
10*	1157590030	ADAPTER	1	
11*	5157590270	BOLT	1	
13*	9813550250	RING	1	
15*	5157510120	HOUSING	1	
16*	9813512050	PISTON	1	
17*	9813513020	SPRING	1	
18*	9813550350	GASKET	1	
19*	8941711850	PLUG	1	
28*	5157540010	TAPPET ASSY.	1	INCLUDES ITEMS W/#
29*#	9813514030	ROLLER	1	
30*#	9813514100	PIN	1	
31*#	1157590020	GUIDE	2	

ISUZU 4BG1 — MISC. INJECTION PUMP ASSY.

MISC. INJECTION PUMP ASSY.

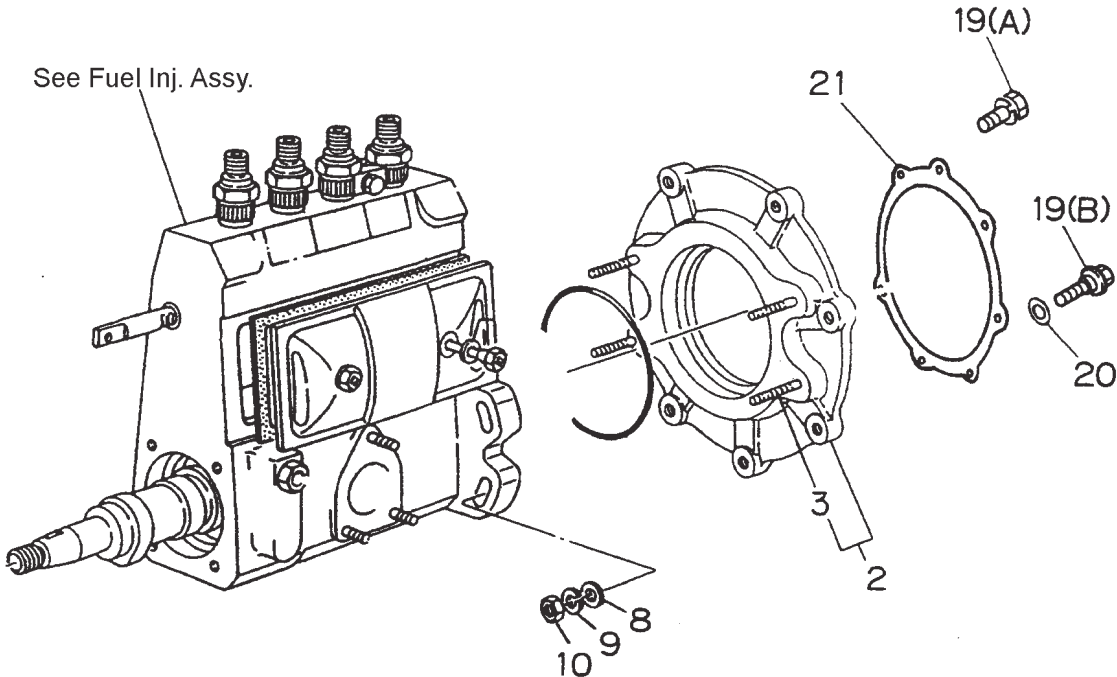

ISUZU 4BG1 — MISC. INJECTION PUMP ASSY.

MISC. INJECTION PUMP ASSY.

<u>NO.</u>	<u>PART NO.</u>	<u>PART NAME</u>	<u>QTY.</u>	<u>REMARKS</u>
2	5197510500	BRACKET	1	
3	9041010300	STUD	4	
8	9091645100	WASHER	4	
9	9091506100	WASHER	4	
10	5156390020	NUT	4	
19 A	5090000841	BOLT	6	M8X55 W/LOCK WASHER
19 B	5090002221	BOLT	1	M8X22
20	9095720080	GASKET	1	
2	8943706750	GASKET	1	

ISUZU 4BG1 — COUPLING ASSY.

COUPLING ASSY.

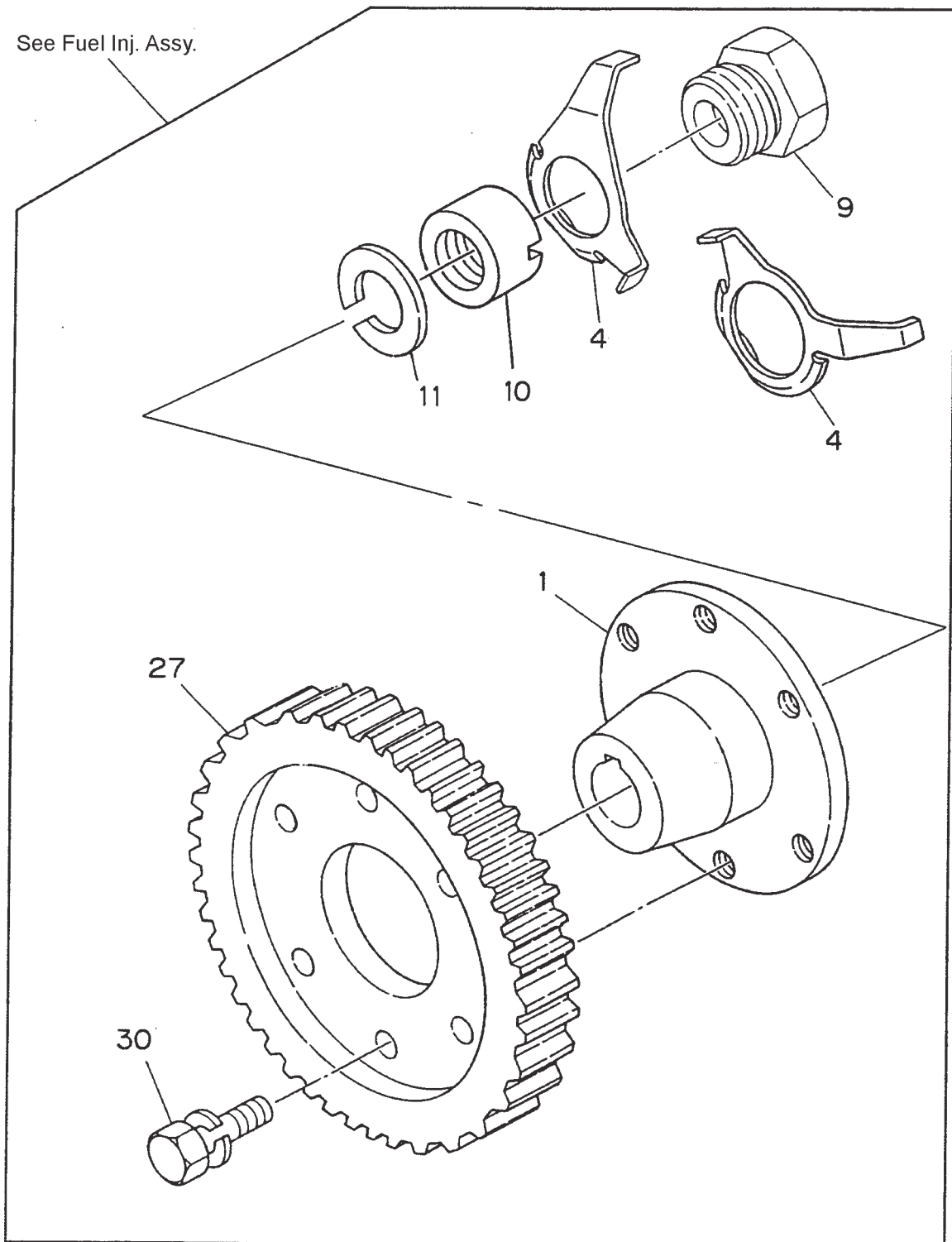

ISUZU 4BG1 — COUPLING ASSY.

COUPLING ASSY.

<u>NO.</u>	<u>PART NO.</u>	<u>PART NAME</u>	<u>QTY.</u>	<u>REMARKS</u>
1	5157810030	COUPLING	1	
4	1156192470	PLATE	1	
9	9096620070	BOLT	1	
10	9884105020	NUT	1	
11	5156190480	WASHER	1	
27	5125240210	GEAR	1	
30	8944575170	BOLT	6	

ISUZU 4BG1 — ACCELERATOR PEDAL ASSY.

ACCELERATOR PEDAL ASSY.

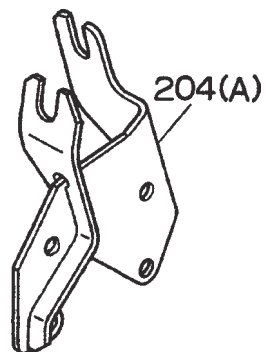

ISUZU 4BG1 — ACCELERATOR PEDAL ASSY.

ACCELERATOR PEDAL ASSY.

<u>NO.</u>	<u>PART NO.</u>	<u>PART NAME</u>	<u>QTY.</u>	<u>REMARKS</u>
204 A	5197890040	BRACKET	1	

AIR DUCT ASSY.

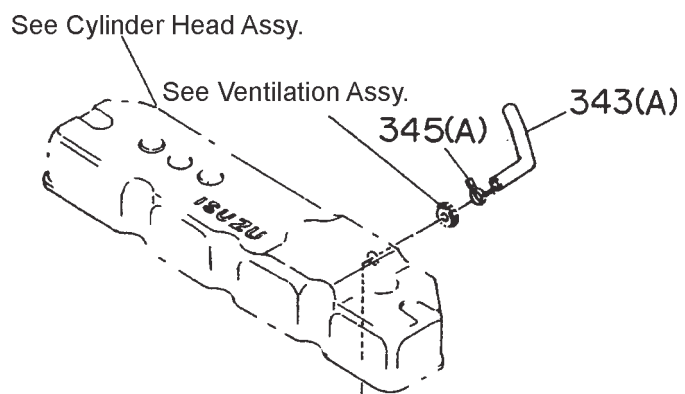

ISUZU 4BG1 — AIR DUCT ASSY.

AIR DUCT ASSY.

<u>NO.</u>	<u>PART NO.</u>	<u>PART NAME</u>	<u>QTY.</u>	<u>REMARKS</u>
343	8943216680	HOSE	1	
345	8942420340	CLIP	2	

ISUZU 4BG1 — FUEL SEDIMENTER ASSY.

FUEL SEDIMENTER ASSY.

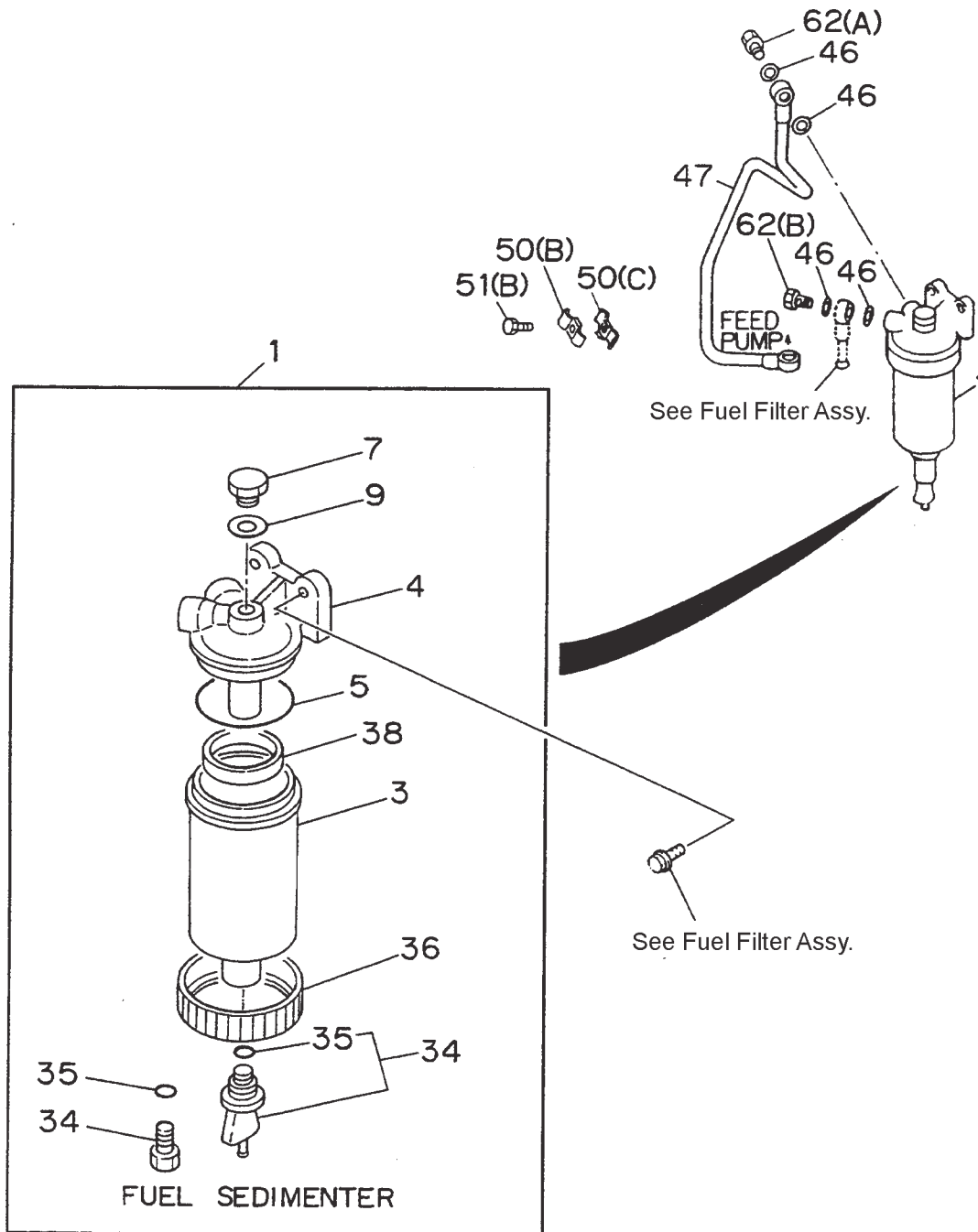

ISUZU 4BG1 — FUEL SEDIMENTER ASSY.

FUEL SEDIMENTER ASSY.

<u>NO.</u>	<u>PART NO.</u>	<u>PART NAME</u>	<u>QTY.</u>	<u>REMARKS</u>
1	1132008410	FUEL SEDIMENTER	1	INCLUDES ITEMS W/%
3%	1132112110	BODY ASSY.	1	
4%	5132120591	COVER	1	
5%	5096230700	GASKET	1	
7%	5132190200	PLUG	1	
9%	5096300240	GASKET	1	
34%	8944537460	PLUG	1	INCLUDES ITEMS W/#
35%#	8944163770	GASKET	1	
36%	5132190221	RING	1	
38%	5132190210	FLOAT	1	
46%	9095720140	GASKET	4	
47	894470470	PIPE	1	
50B	1097007590	CLIP	2	
51B	9097161140	CLIP	3	
50C	1097007600	CLIP	2	
50C	9097161240	CLIP	3	
51	0500406200	BOLT	7	
62A	9099063251	BOLT	1	
62B	5157590270	BOLT	1	

CLUTCH ASSY.

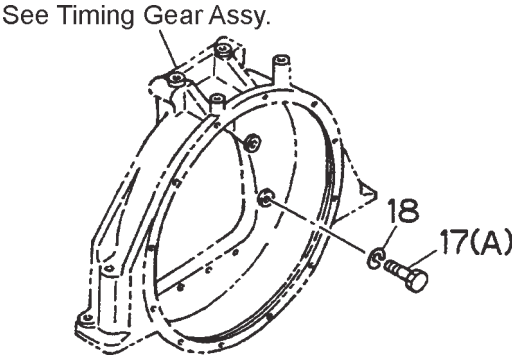

ISUZU 4BG1 — CLUTCH ASSY.

CLUTCH ASSY.

<u>NO.</u>	<u>PART NO.</u>	<u>PART NAME</u>	<u>QTY.</u>	<u>REMARKS</u>
17	9910664500	BOLT	6	
18	9091505140	LOCKWASHER	6	

ISUZU 4BG1 — SWITCH AND RELAY ASSY.

SWITCH AND RELAY ASSY.

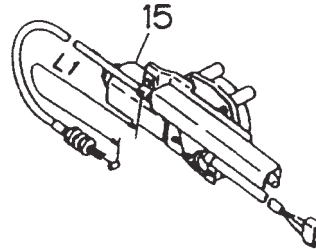
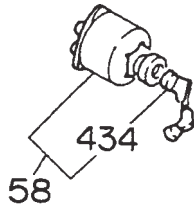
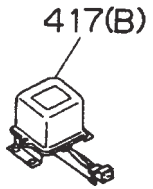

ISUZU 4BG1 — SWITCH AND RELAY ASSY.

SWITCH AND RELAY ASSY.

<u>NO.</u>	<u>PART NO.</u>	<u>PART NAME</u>	<u>QTY.</u>	<u>REMARKS</u>
15	1819001372	ENG. STOP ACTUATOR	1	
58	1823100080	IGNITION SWITCH	1	INCLUDES ITEM W/%
417	1825500732	EMERGENCY RELAY	1	
434%	KEYISUZUF	KEY	1	

PAYMENT TERMS

Terms of payment for parts are net 10 days.

FREIGHT POLICY

All parts orders will be shipped collect or prepaid with the charges added to the invoice. All shipments are F.O.B. point of origin. Multiquip's responsibility ceases when a signed manifest has been obtained from the carrier, and any claim for shortage or damage must be settled between the consignee and the carrier.

MINIMUM ORDER

The minimum charge for orders from Multiquip is \$15.00 net. Customers will be asked for instructions regarding handling of orders not meeting this requirement.

RETURNED GOODS POLICY

Return shipments will be accepted and credit will be allowed, subject to the following provisions:

1. A Returned Material Authorization must be approved by Multiquip prior to shipment.
2. To obtain a Return Material Authorization, a list must be provided to Multiquip Parts Sales that defines item numbers, quantities, and descriptions of the items to be returned.
 - a. The parts numbers and descriptions must match the current parts price list.
 - b. The list must be typed or computer generated.
 - c. The list must state the reason(s) for the return.
 - d. The list must reference the sales order(s) or invoice(s) under which the items were originally purchased.
 - e. The list must include the name and phone number of the person requesting the RMA.
3. A copy of the Return Material Authorization must accompany the return shipment.
4. Freight is at the sender's expense. All parts must be returned freight prepaid to Multiquip's designated receiving point.

5. Parts must be in new and resalable condition, in the original Multiquip package (if any), and with Multiquip part numbers clearly marked.
6. The following items are not returnable:
 - a. Obsolete parts. (If an item is in the price book and shows as being replaced by another item, it is obsolete.)
 - b. Any parts with a limited shelf life (such as gaskets, seals, "O" rings, and other rubber parts) that were purchased more than six months prior to the return date.
 - c. Any line item with an extended dealer net price of less than \$5.00.
 - d. Special order items.
 - e. Electrical components.
 - f. Paint, chemicals, and lubricants.
 - g. Decals and paper products.
 - h. Items purchased in kits.
7. The sender will be notified of any material received that is not acceptable.
8. Such material will be held for five working days from notification, pending instructions. If a reply is not received within five days, the material will be returned to the sender at his expense.
9. Credit on returned parts will be issued at dealer net price at time of the original purchase, less a 15% restocking charge.
10. In cases where an item is accepted, for which the original purchase document can not be determined, the price will be based on the list price that was effective twelve months prior to the RMA date.
11. Credit issued will be applied to future purchases only.

PRICING AND REBATES

Prices are subject to change without prior notice. Price changes are effective on a specific date and all orders received on or after that date will be billed at the revised price.

Rebates for price declines and added charges for price increases will not be made for stock on hand at the time of any price change.

Multiquip reserves the right to quote and sell direct to Government agencies, and to Original Equipment Manufacturer accounts who use our products as integral parts of their own products.

SPECIAL EXPEDITING SERVICE

A \$35.00 surcharge will be added to the invoice for special handling including bus shipments, insured parcel post or in cases where Multiquip must personally deliver the parts to the carrier.

LIMITATIONS OF SELLER'S LIABILITY

Multiquip shall not be liable here under for damages in excess of the purchase price of the item with respect to which damages are claimed, and in no event shall Multiquip be liable for loss of profit or good will or for any other special, consequential or incidental damages.

LIMITATION OF WARRANTIES

No warranties, express or implied, are made in connection with the sale of parts or trade accessories nor as to any engine not manufactured by Multiquip. Such warranties made in connection with the sale of new, complete units are made exclusively by a statement of warranty packaged with such units, and Multiquip neither assumes nor authorizes any person to assume for it any other obligation or liability whatever in connection with the sale of its products. Apart from such written statement of warranty, there are no warranties, express, implied or statutory, which extend beyond the description of the products on the face hereof.

OPERATION AND PARTS MANUAL

HERE'S HOW TO GET HELP

PLEASE HAVE THE MODEL AND SERIAL
NUMBER *ON-HAND* WHEN CALLING

MQ Power

1800 Water Ridge Rd. Tel. (800) 883-2551
Suite 500/600 Fax (972) 315-1847
Lewisville, TX 75057
Contact: mqpower@multiquip.com
Web: www.mqpower.com

MQ Parts Department

800-427-1244 Fax: 800-672-7877
310-537-3700 Fax: 310-637-3284

Service/Tech Support/Warranty

800-835-2551 Fax: 310-638-8046

© COPYRIGHT 2007, MULTIQUIP INC.

MQ Power and the MQ Power logo are registered trademarks of Multiquip Inc. and may not be used, reproduced, or altered without written permission. All other trademarks are the property of their respective owners and used with permission.

This manual MUST accompany the equipment at all times. This manual is considered a permanent part of the equipment and should remain with the unit if resold.

The information and specifications included in this publication were in effect at the time of approval for printing. Illustrations are based on the *DCA-45SSIU2 WHISPERWATT™ GENERATOR*. Illustrations, descriptions, references and technical data contained in this manual are for guidance only and may not be considered as binding. Multiquip Inc. reserves the right to discontinue or change specifications, design or the information published in this publication at any time without notice and without incurring any obligations.

Your Local Dealer is:

Manufactured for
Multiquip Inc.
by
DENYO CO., LTD, JAPAN

