

LAVINA®



LAVINA® 7 EN Pro User Manual



 **SUPERABRASIVE**

www.superabrasive.com | info@superabrasive.us

CONTENT

1. GENERAL INFORMATION

Preface	3
Manufacturer	3
General Description	3
Machine Characteristics	3
Lavina7N Pro Main Design	3
Environmental Conditions	3
Electrical Connection	3
Vacuum Connection	4
Technical Data	4
Vibrations	4
Sonorous Emissions	4
Label Data	4
Customer service	4

2. SAFETY INSTRUCTIONS

Recommended Use	4
Prohibited Use	4
Preparation for Work	..5
Protection Devices	5
Arrest Functions	5
Safe Use	5
Residual Risks	5
Before You Begin	5
Operating the Machine	5
After Work is completed	5
The Work Area	5
Personal Protective Equipment (PPE)	5
Operator	5

3. OPERATION

Preliminary Controls	6
Mounting Tools	6
Leveling after Mounting the tool	6
Adjusting Handle and Swiveling Carriage	6
Tool Protecting Guard	..7
Control Board	7
Starting the Machine	7
Operating Machine	7
Stopping Machine	7

4. TOOLS AND ACCESSORIES

Weights	8
Tool holder key	8
Foam plate	8
Floating Backer Plate	8

5. SPARE PARTS

Assembly and Parts Specifications	9
Assembly and parts specification main Wheel Support	10
Assembly and parts specification main Stair Wheel Support	10
LAVINA® 7 EN Pro Assembly and parts specification of the electrical and control box 200-240 Volt	11

6. MAINTENANCE AND INSPECTION

First Use	12
Cleaning	12
Check Daily	12
Check Every 200 Working Hours	12
Check Every 400 Working Hours	12
Vacuum	12
Mechanical Parts	12
Electrical System	12
One phase connection	12
Electrical System	13
Lavina 7 E Pro Electrical schemes 208-240 Volt	13
Lavina 7 E Pro Electrical schemes Connection Main Circuit terminals	13

7. TROUBLESHOOTING

Index of Problems and Solutions	
Replacing Power Cord and Plugs	14
Tensioning the Belts	14
Replacing the Belts	15
Motor Connection	15
Fault Diagnosis Inverter Yaskawa 1000	16

8. WARRANTY AND RETURNS

Warranty Policy	19
Return Policy	19

9. DISPOSAL

19

10. MANUFACTURER'S CONTACTS

19

1. GENERAL INFORMATION

This owner's manual is intended for the operator of the LAVINA® 7 EN Pro machine, the servicing technician as well as for anyone involved with operating or servicing the machine. We recommend that you read the instructions very carefully and follow them strictly. The manual includes information about assembling, using, handling, adjusting and maintaining your LAVINA® 7 EN Pro floor grinding and polishing machine.

MANUFACTURER

Superabrasive was founded 24 years ago, in 1987, as a manufacturer of high quality diamond tools for the stone and concrete industry. Today, Superabrasive is one of the world's leading companies in the production of diamond tools and floor grinding machinery. At Superabrasive, we strive to deliver the very best solutions to our customers, and enable them to work more efficiently.

GENERAL DESCRIPTION

The LAVINA® 7 EN Pro machine is intended for grinding, polishing and buffing concrete, marble, granite, limestone and terrazzo surfaces with diamond tools.

The LAVINA® 7 EN Pro is a one-disc machine.

The LAVINA® 7 EN Pro is intended to grind/polish edges, corners, steps of stairs or difficult to reach surfaces. Additionally, the machine could be used for grinding wood floor surfaces.

For best results, use only tools manufactured or recommended by Superabrasive and its distributors.

WARNING!

The LAVINA® 7 EN Pro machine is manufactured and fitted for the above-mentioned applications only! Every other use may possess risks to the persons involved.

MACHINE CHARACTERISTICS

The LAVINA® 7 EN Pro is made so it can grind/polish surfaces, where bigger machines have difficulties to reach.

LAVINA® 7 EN PRO MAIN DESIGN



Figure 1.1



Figure 1.3

- **The carriage** is swiveling 30° to both sides. The machine can be pushed straight and the grinding can follow a wall. The normal wheel support can be changed with a "stair" wheel support, which can be adjusted in height to work on stairs.
- **The halogen spotlight** (Fig.1.2) enables the operator to work in darker areas.
- **⚠ WARNING** Existing lighting system does not replace adequate overhead lighting.
- **The frame** The handle on the frame is adjustable in height and allows the operator to work in a correct and safe posture.
- **The electrical box** (fig.1.3) contains the electric switching devices and the
- **inverter.** The motor feeding cable and the main feeding are located on the bottom of the box.
- **The motor** is mounted on the base plate. The motor is driving the grinding head with a belt system.



Figure 1.2

ENVIRONMENTAL CONDITIONS

The temperature range for operating the LAVINA® 7 EN Pro outdoors is between 41°F and 86°F or 5°C and 30°C. Never use the LAVINA® 7 EN Pro during rain or snow when working outdoors. When working indoors, always operate the machine in well-ventilated areas.

ELECTRICAL CONNECTION

The voltage (Volt) and power (Ampere) are displayed on a label on the electrical control box to avoid any incorrect connection. Refer to these before connecting the power. To avoid electrical shocks, make sure the ground power supply is functioning properly.

VACUUM CONNECTION

A connection for a vacuum dust extractor is located on the handle. The LAVINA® 7 EN Pro does not include a vacuum dust extractor. The customer must purchase the vacuum dust extractor separately. The hose of the vacuum extractor must be Ø 50 mm and can be glided over the pipe. The vacuum dust extractor must be adapted for floor grinders and have a minimum air displacement of 300m³/h with a negative vacuum of 21 kPa.

TECHNICAL DATA

	LAVINA® 7 EN Pro	
Voltage/Hz	1 ph x 208-240 V 50/60Hz	
Amperage	Max 15 Amps	
Power	2.2 kW	3 hp
Tool holder rpm	500-1100 rpm	
Working width	175 mm	7"
Tool holder diameter	165 mm	6.5"
Tool diameter	175 mm	7"
Weight	64 kg	132 lbs
Grinding pressure	20 kg	42 lbs
Additional weight	max 4x2,5 kg	22 lbs
Application	dry	
Cable length	17.4 m	57 ft
Machine LxWxH	790x400x915 mm	31"x16" x44"
Packing LxWxH	730x730x1050 mm	28,7"x28,7"x41,4"

CE-CERTIFICATION

The LAVINA® 7 EN Pro machine is designed to operate correctly in an electromagnetic atmosphere of industrial type and is equipped with all the mechanical and electrical safety protections in conformity with the following European CEE rules and regulations:

The LAVINA® 7 EN Pro machine complies with the Safety Directive for machines 2006/42/EC, the EMC Directive 2004/108/EC and the Low Voltage Directive 2006/95/EC.

Also complies with the norms in use BDS EN ISO 12100-1, BDS EN ISO 12100-2, BDS EN 13862, BDS EN ISO 13857, BDS EN 349, BDS EN ISO 13850, BDS EN 13732-1, BDS EN 953, BDS EN ISO 13849-1, BDS EN 1037, BDS EN ISO 11201, BDS EN ISO 3744, BDS EN 1033:2002, BDS EN ISO 14121-1, BDS EN 60204-1, BDS EN 61000-6-4. Test results are a part of the machine's technical information and can be sent upon a special request. The machine is delivered with the CE mark exposed and provided with a EC declaration of conformity.

VIBRATIONS

The vibrations of the machine are measured in compliance within the standard BDS EN 1033:2002. The vibration on the handles of the LAVINA® 7 EN Pro, working in normal conditions, is less than 2,5 m/s² with recommended tools.

SONOROUS EMISSIONS

Sonorous emissions are measured in compliance with the standards BDS EN ISO 3744:2010 and BDS EN ISO 11201:2010. The sound pressure level at the workplace is L_{pA}=73 dB(A). The sound power level is L_w(A)=88,5 dB(A). However, as previously stated, the operator must wear ear protectors.

LABEL DATA

The data on the label provides the correct voltage and kW (needed for operational purposes); Weight (needed for transportation purposes); production year and serial number (needed for maintenance purposes).

CUSTOMER SERVICE

For customer assistance and technical support contact your local distributor or contact the producer Superabrasive Ltd. or visit us at www.superabrasive.com, where you can download a copy of this manual.

2. SAFETY INSTRUCTIONS

RECOMMENDED USE

The LAVINA® 7 EN Pro machine is designed and manufactured to grind and polish concrete, terrazzo and natural stone floors. It can be used for renovations as well as for polishing. The machine is designed for dry use. Use a vacuum of appropriate size. For more information, please refer to the chapter on handling the vacuum connection.



WARNING

PROHIBITED USE

The machine **MUST NOT** be used:

- For applications different from the ones stated in the General Description chapter.
- For not-suitable materials.
- In environments which:
- Possess risks of explosion



WARNING

- Possess high concentration of powders or oil substances in the air
- Possess risks of fire
- Feature inclement conditions.
- Possess electromagnetic radiation.

PREPARATION FOR WORK



WARNING

Make sure that:

- You have closed the work area, so that no person unfamiliar with operating the machine can enter the area
- The tool plate and tools are adjusted to the machine properly
- There are no missing parts of the machine
- The machine is in upright working position
- The protection devices are working properly.
- The electrical cable is free to move and follow the machine easily. In order to keep the electrical cable from being damaged, no vehicle should cross the zone where electrical cables are situated.

PROTECTION DEVICES



WARNING

- The machine is equipped with several protection devices including the following:
- An emergency stop button
- A protection skirt and a hood for protecting the tool plates.
- These devices protect the operator and/or others persons from potential injuries. Do not remove them. On contrary, before using the machine, please ensure that all protection devices are mounted and function properly.

ARREST FUNCTIONS



WARNING

Functions of arresting of the machine are following:

- Button to stop the motor (category 1)
- Emergency button (category 1)

SAFE USE



WARNING

- The LAVINA® 7 EN Pro is designed to eliminate all risks correlated with its use. However, it is not possible to eliminate the risks of an eventual accident with the machine. Unskilled or uninstructed operator may cause correlated residual risks. Such risks are:
 - Position Risks due to operator's incorrect working position
 - Tangling up Risks due to wearing inappropriate working clothes
 - Training Risks due to lack of operational training

NOTE: In order to reduce all consequences of the above-mentioned risks, we advise that machine operators will follow the instructions in the manual at all times.

RESIDUAL RISKS



WARNING

- During the normal operating and maintenance cycles, the operator is exposed to few residual risks, which cannot be eliminated due to the nature of the operations.

BEFORE YOU BEGIN



WARNING

- Working area must be clear from any debris or objects.
- A first-time operator must always read the manual and pay attention to all safety instructions.
- All electric connections and cables must be inspected for potential damages.

- Ground wire system of the power supply must be also inspected.
- Perform general daily inspections of the machine and inspect the machine before each use.
- Always inspect the safety devices:
- The emergency break must be clear and working
- The tool protector must be working
- The machine must be clean
- Never operate the machine in the rain!
- Confirm that there are no missing parts especially after transportation, repair or maintenance.

OPERATING MACHINE



WARNING

- When operating the LAVINA® 7 EN Pro, make certain that there is no one, but you around the machine.
- Never leave the machine unattended while working.
- The electrical cable must move freely and must be damage-free.
- Check if the floor, you work on, is not too uneven. If this is the case, it may damage the machine.

AFTER WORK IS COMPLETED



WARNING

- Clean the machine and its surroundings properly
- Unplug the machine and wind up the electrical cable
- Store the machine in a safe place

THE WORK AREA



WARNING

- Make certain that people or vehicles do not enter the work area.
- Avoid cables and hoses being in the way.
- Always check the floor for debris

PERSONAL PROTECTIVE EQUIPMENT (PPE)



WARNING

- Always wear safety shoes when working with the machine.
- Always wear ear protectors when working with the machine.
- All personnel in the immediate work area must wear safety glasses with side shields.
- Always wear safety gloves when changing the tools.
- Always wear clothes suitable for the work environment.

OPERATOR



WARNING

- The LAVINA® 7 EN Pro machine.
- The operator must know the machine's work environment.
- Only one operator at a time can work with the machine.
- The operator must be properly trained and well instructed prior operating the machine.
- The operator must understand all the instructions in this manual.
- The operator must understand and interpret all the drawings and designs in manual.
- The operator must know all sanitation and safety regulations pertaining to the operation of
- The operator must have floor grinding experience.
- The operator must know what to do in case of emergency.
- The operator must have an adequate technical knowledge and preparation.

3. OPERATION

PRELIMINARY CONTROLS

Inspect the working area as explained in the safety instructions. For dry use connect the vacuum extractor and ensure that the vacuum hose is clear and it will follow the machine easily. Plug in the machine and make sure that the power cord is free to follow the working direction of the LAVINA® 7 EN Pro.

MOUNTING TOOLS



Figure 3.1



Figure 3.2



Figure 3.3

Mount the tools only after ensuring that there is enough diamond bond material left. Be sure that the plates are always clean before mounting. Unplug the machine before dismounting or mounting the tools. Always use the tool holder key, turn the butterfly in the middle to ensure the tool (Fig.3.1).

Diamond tools with Velcro are attached on the foam plate of 7 inch (Fig. 3.3). The foam plate (is mounted the same way as the other tools (Fig. 3.2).

LEVELING AFTER MOUNTING THE TOOL



Figure 3.4



Figure 3.5

To ensure the tool works flat on the floor, the machine has to be leveled. On top of the base plate is mounted a round water level (Fig. 3.5). Attention using the water level should be done only on a flat surface.

To level the machine, turn the knob between the wheels (Fig. 3.4).

ADJUSTING HANDLE AND SWIVELLING CARRIAGE



Figure 3.6



Figure 3.7



Figure 3.8

For adjusting the handle in height, turn loose the swivel bolt, after finding the right position lock it back (Fig. 3.6).

Find the right angle of working the machine (Fig. 3.7), swivel left or right the carriage by unblocking the turning wheel (Fig. 3.8).

TOOL PROTECTING GUARD

Turn the tool protecting guard in the preferred position. Adjust the height according to the tool while mounting on the "Velcro" strip. (Fig. 3.9)



Figure 3.9

THE CONTROL BOARD

- | | |
|----------------------------|--|
| 1. Lamp jack | plug out/in the lamp when needed |
| 2. Reset button | resets the alarm of the inverter |
| 3. Power led | lights green when the power is on |
| 4. Emergency button | used in Emergency situations for stopping the motor |
| 5. ON button | starts motor |
| 6. OFF button | Stops motor |
| 7. Potentiometer | changes the RPM of the grinding plates,
from 500-1100 rpm |



Figure 3.10

STARTING THE MACHINE

First, follow the directions in chapter Safety Devices and Safety Instructions. Next, pull the emergency stop (Fig. 3.10 4) to ensure that the machine is in working condition. Check the potentiometer (Fig. 3.10 7) and ensure that it is set at the working speed. Switch on the vacuum unit. Finally, hold the machine firmly and push the start button (Fig. 3.10 5).

OPERATING THE MACHINE

Guide the machine in straight lines across the floor, and with each new line overlap a little bit of the previously completed surface. Work at a constant speed allowing the tools time to work at a speed appropriate for the tools' grit size. Avoid vibrations. Do not stop the LAVINA® 7 EN Pro machine in one spot while the tools are still working because they will leave marks on the floor surface. Check the floor surface periodically to ensure that dust is not accumulating on the surface, also check regularly if your vacuum works properly.

STOPPING THE MACHINE

The stopping of the machine must be done gradually until the motor stops. Do not stop moving the machine before arresting the motor as the tools could damage the surface. Switch off with the off button (Fig. 3.10 6). Use the Emergency button (Fig. 3.10 4) only in emergency or use it to switch the power totally off. Remember not to hold the machine in one spot before turning off the motor.

4. TOOLS AND ACCESSORIES

WEIGHTS

Superabrasive offers additional weights for increasing the productivity of the machine (Fig.4). Each additional weight weighs about 5.5 lbs or 2,5 kg. Each individual application, type and condition of surface, power capacity of the outlet, etc. will determine the number of weights you can use without tripping a breaker, Although with a maximum of four. The weight stacks on to central shaft above the tools around the outer bowl (Fig.4.1).

The additional weight depends on the tools; it is not always possible to add weights. Some tools work too aggressively and the machine can stop.



Figure 4.1

TOOL HOLDER KEY

The tool holder key (Fig. 4.2) is used for adjusting, mounting and dismounting of the tools. Always use the key for mounting.



Figure 4.2

mounting and dismounting of the tools. Item number is A03.00.00.00

FOAM PLATE

Diamond tools with Velcro are mounted on the foam plate 7“(Fig.4.3). The foam plate is mounted on the flexible backer plate. Item number is LV-7-FP

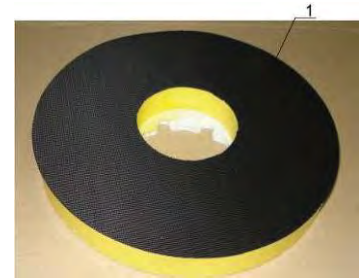

Figure 4.3

FLOATING BACKER PLATE

A floating backer plate (Fig. 4.3) is mounted on the grinding head. Its advantage is that it has elastic shock absorbers, which enable the tool plate to float and follow the surface profile. A tool can be attached with use of the tool holder key.

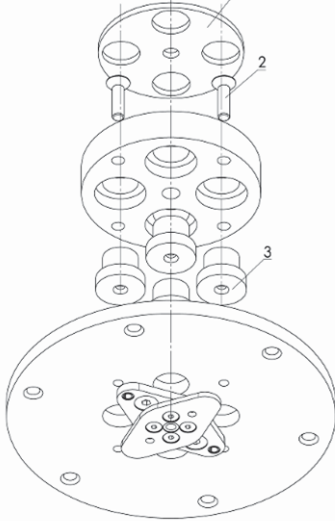

Figure 4.3

	Item Number	Description	Qty.
1	A01/00.00.02	Sealer Front	1
2	M6x20DIN7991	Screw	4
3	A01/00.00.01	Shock Absorber	4

To order any parts, customer has to provide the machine model and serial number. Without this information, customer is responsible for ordering the correct part, and no shipping charges will be refunded if the part ordered is wrong.

5. SPARE PARTS

LAVINA® 7 EN PRO ASSEMBLY AND PARTS SPECIFICATION (FIG. 5.1)

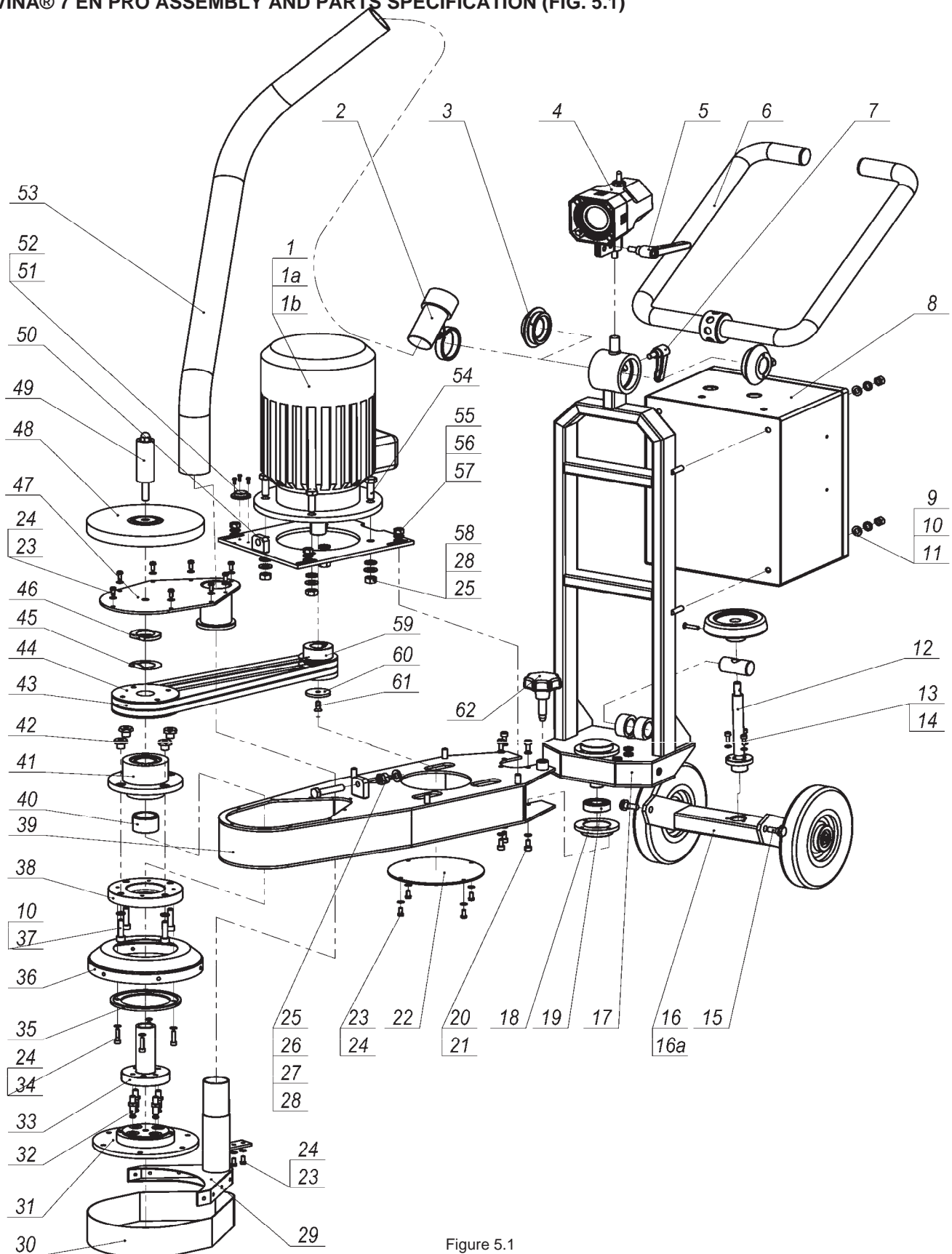

Figure 5.1

To order any parts, customer has to provide the machine model and serial number. Without this information, customer is responsible for ordering the correct part, and no shipping charges will be refunded if the part ordered is wrong.

No	Item Number	Description	Qty.
1	L7NP-00.00.00.10	Electro Motor	1
1a	L7NP-00.00.00.11	Fan Cover	1
1b	L7NP-00.00.00.12	Fan	1
2	LC-57-08.00.00.00	Air Duct Connection	1
3	L25SPS-02.00.00.18	Nut	2
4	L25SPS-01.00.00.00	Lamp Holder Unit	1
5	A58165	Swivel Bolt	1
6	LC-7-05.00.00.00	Handle Assembly	1
7	A58194	Swivel Bolt	1
8	L7NP-05.00.00.00	Control Box	1
9	M8DIN125A	Washer	4
10	M8DIN7980	Spring Washer	8
11	M10DIN933	Bolt	4
12	L7P-03.00.00.00	Leveling Wheel Assembly	1
13	M5DIN127B	Spring Washer	3
14	M5x12DIN912	Screw	3
15	LC-57-00.00.00.49	Swivel Bolt	2
16	L7P-02.00.00.00	Normal Wheel Support	1
16a	L7P-06.00.00.00	Stair Wheel Support	1
17	L7NP-01.02.00.00-03	Back Housing Ass.	1
18	L7P-01.00.00.01	Roller Assembly Cap	2
19	6004	Roller Assembly	2
20	M6x12DIN912	Screw	6
21	M6DIN7980	Spring Washer	6
22	LC-57-00.00.00.57	Bottom Cover	1
23	M5x10DIN84A	Screw	14
24	M5DIN6798A	Washer	18
25	M10DIN125A	Washer	5
26	M10DIN439	Nut	1
27	M10x50DIN933	Bolt	1
28	M10DIN934	Nut	5
29	LC-57-03.00.00.00	Vacuum Port	1

No	Item Number	Description	Qty.
30	LC-57-00.00.00.33	Guard	1
31	A01/00.00.00	Floating Back Up Plate	1
32	LC-57-00.00.00.38	Pin	4
33	LC-57-00.00.00.36	Shaft Extension	1
34	M5x20DIN912	Bolt	4
35	LC-57-00.00.00.40	Cap	1
36	LC-57-00.10.00.00	Cover	1
37	M8x30DIN912	Bolt	4
38	LC-57-00.00.00.41	Insert	1
39	L7P-01.01.00.00	Front Housing	1
40	LC-57-00.00.00.37	Bushing	1
41	LC-57-11.00.00.00	Spindle Housing	1
42	LC-57-00.00.00.51	Nut	4
43	SPZ934	Belt	2
44	LC-57-00.00.00.43	Grinding Pulley	1
45	LC-57-00.00.00.47	Washer	1
46	LC-57-00.00.00.44	Nut	1
47	LC-57-02.00.00.00	Top Cover Assembly	1
48	LC-57-12.00.00.00	Guide Assembly	1
49	LC-57-00.11.00.00	Weights Holder	1
50	L7P-04.00.00.00	Motor Base Assembly	1
51	DF30	Water level	1
52	M3x8DIN84A	Screw	3
53	D40L860	Air Duct Hose	1
54	M10x30DIN912	Bolt	4
55	M8DIN934	Nut	4
56	M8DIN127B	Spring Washer	4
57	M8DIN433	Washer	4
58	M10DIN127B	Spring Washer	4
59	LC-57-00.00.00.29	Motor Pulley	1
60	L25SPS-00.00.00.15	Washer	1
61	M6x20DIN84A	Screw	1
62	L7P-00.00.00.02	Knob	1

**LAVINA® 7 EN PRO ASSEMBLY AND PARTS SPECIFICATION (FIG. 5.2)
WHEEL SUPPORT**

No	Item Number	Description	Qty.
1	L7P-02.01.00.00	Wheel Support Frame	1
2	M5x16DIN7991	Screw	2
3	LC-7P-09.00.00.03	Washer	2
4	VPA175-8K	Wheel	2

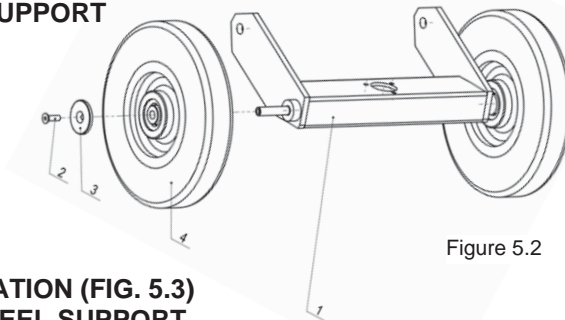

Figure 5.2

**LAVINA® 7 EN PRO ASSEMBLY AND PARTS SPECIFICATION (FIG. 5.3)
STAIR WHEEL SUPPORT**

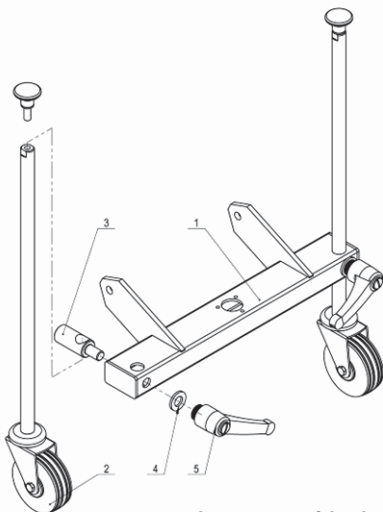

Figure 5.3

No	Item Number	Description	Qty.
1	L7P-06.01.00.00	Stair Wheel Support Frame	1
2	L7P-06.02.00.00	Wheel assembly	2
3	L7P-06.00.00.03	Clamp	2
4	M12DIN125A	Washer	2
5	M12x19A580-80	Swivel bolt	2

To order any parts, customer has to provide the machine model and serial number. Without this information, customer is responsible for ordering the correct part, and no shipping charges will be refunded if the part ordered is wrong.

LAVINA® 7 EN PRO ASSEMBLY AND PARTS SPECIFICATION OF THE CONTROL BOX (FIG. 5.4)

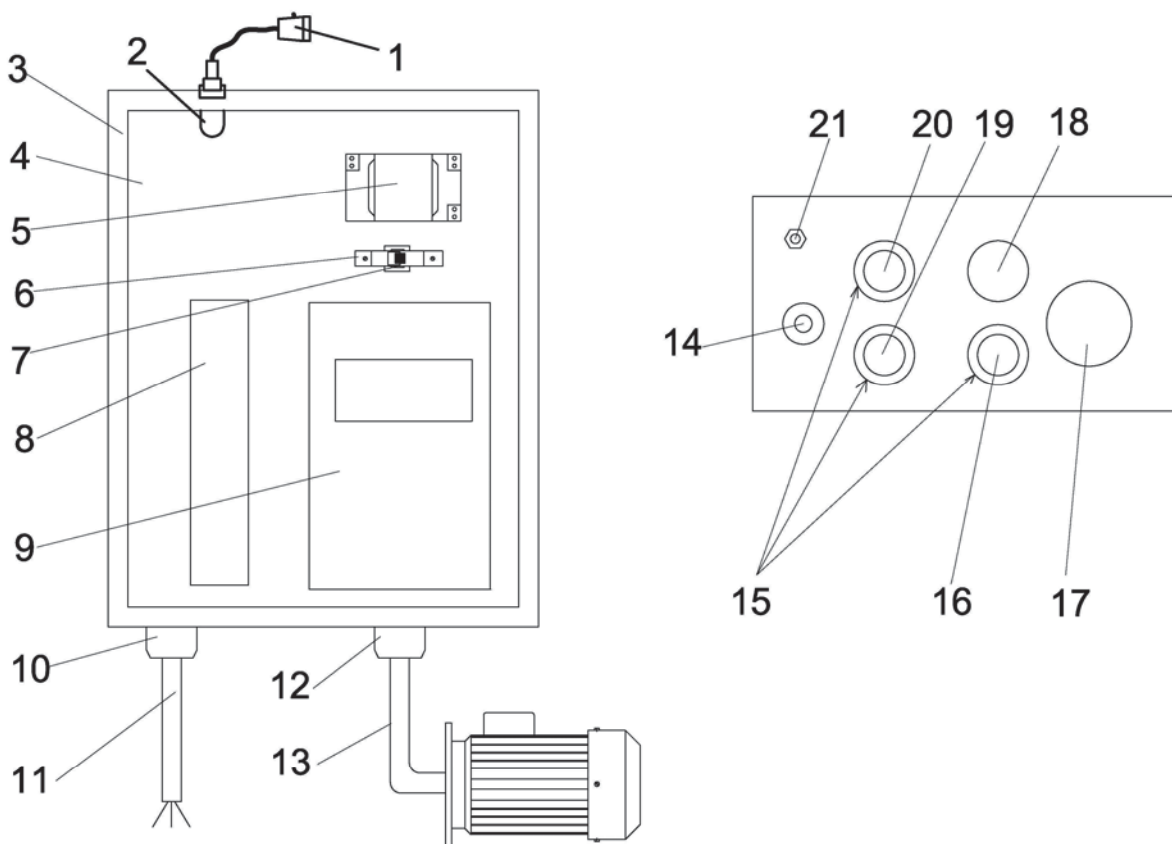

Figure 5.4

208-240 Volt

No	Item Number	Description	Qty.
1	L25SPS-01.00.00.00	Lamp Unit Incl. Cable and Plug	1
2	0.625x1/2	Cap	
3	CM-3025/200	Metal Box	
4	MM3025	Plate	1
5	230/12/24V/50/46/4VA	Transformer	1
6	NB1-63/1P/4A	Circuit Breaker	1
7	20MM	Rail	1
8	3G3MJVPFI-1020-E	Filter	1
9	CIMRUVBA0012FAA	Inverter Yaskawa (V1000)	1
10	M20x1.5	Cable Gland	1
11	HO7BQ-F3x2.5—17.4M	Cable	1
12	PG16	Cable Gland	
13	HO7BQ-F4x2.5-0.7	Cable	
14	SZ1RV1207	Potentiometer	1
15	ZBPO	Cap	1
16	NP2-BA31	Button	3
17	XB7-ES542.P	Emergency Stop	1
18	ND16-22-CS/2GREEN	Led Green	1
19	NP2-BA42	Button	1
20	XB4BW36B5	Button	1
21	D9.3	Female Jack	1

To order any parts, customer has to provide the machine model and serial number. Without this information, customer is responsible for ordering the correct part, and no shipping charges will be refunded if the part ordered is wrong.

6. MAINTENANCE AND INSPECTION

FIRST USE

Before first use please mount the Levelling Wheel Assembly in place. Put the transverse shaft (Fig. 6.1 4) in position on top of the back housing assembly (Fig. 5.1 17). Turn the shaft (Fig. 6.1 3) from under the back housing assembly (Fig. 5.1 17) through the transverse shaft (Fig. 6.1 4) mount the turning wheel (Fig. 6.1 6) and secure with screw (Fig. 6.1 5).

CLEANING

Keep your machine clean. Cleaning the machine on a regular basis will help detect and solve potential problems before they cause damage to the machine. Most importantly, check and clean the tool plate connections, power cord and plugs, vacuum hoses.

CHECK DAILY

After operating the LAVINA® 7 EN Pro, the operator should conduct a visual inspection of the machine. Any defect should be solved immediately. Pay attention to power cords, plugs and vacuum hoses.

Shock absorbers A01/00.00.01 (See page Floating backer plate) are consumables and have to be checked daily and replaced if needed.

CHECK AND REPLACE AFTER THE FIRST 15 WORKING HOURS

Check the belt tension after 15 hours working with the machine.

For the correct tension, see TROUBLESHOOTING.

CHECK EVERY 200 WORKING HOURS

Every 200 working hours, the operator should inspect all parts of the machine carefully. Most importantly, inspect and clean the tool plate connections, power cord and plugs, vacuum. Check the guard assembly. Make certain the wheels are clean and rotate properly. Inspect the control buttons. If there are defective control parts, they should be replaced immediately. Replace worn vacuum- and water hoses. Carefully inspect the seal rings and bearings of the grinding units, and replace any showing signs of excessive wear.

For more information, refer to chapter troubleshooting below.

CHECK EVERY 400 WORKING HOURS

Besides the checks of 200 working hours, open up the bottom cover like described in chapter "TROUBLE SHOOTING REPLACING BELT". Check if sealers, belt and bearings are in good condition, change if needed. Beware by tensioning the belt not to "over tension"; the belt will never regain his original tension.

VACUUM

As stated previously, frequently check hoses and other parts for clogging.

MECHANICAL PARTS

Parts such as the belt, seal rings, cap rings, spiders and buffers and guard assembly are subject to wear and should be replaced as needed.

ELECTRICAL SYSTEM

Dust should not enter the control box as it will destroy the contacts. Remove (blow out) any dust present.

ONE PHASE CONNECTION

Please note: the power cable has 3 wires, one ground is yellow/green the other 2 other colors are "hot" wires and should be connected to the phases. (Fig. 6.2)

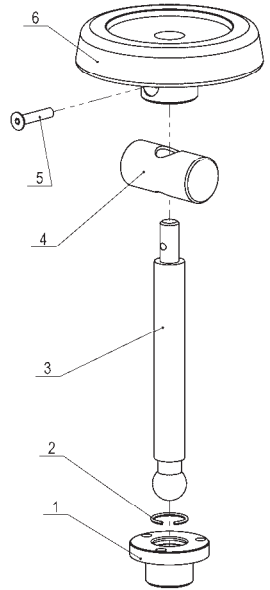

Figure 6.1

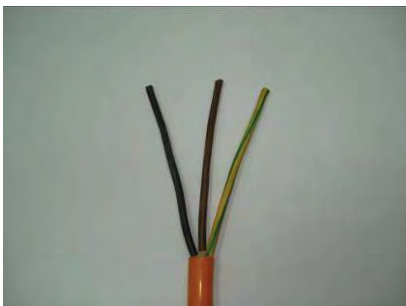

Figure 6.2

ELECTRICAL SYSTEM

LAVINA® 7 EN PRO ELECTRICAL SCHEMES WITH YASKAWA INVERTER

208-240 Volt

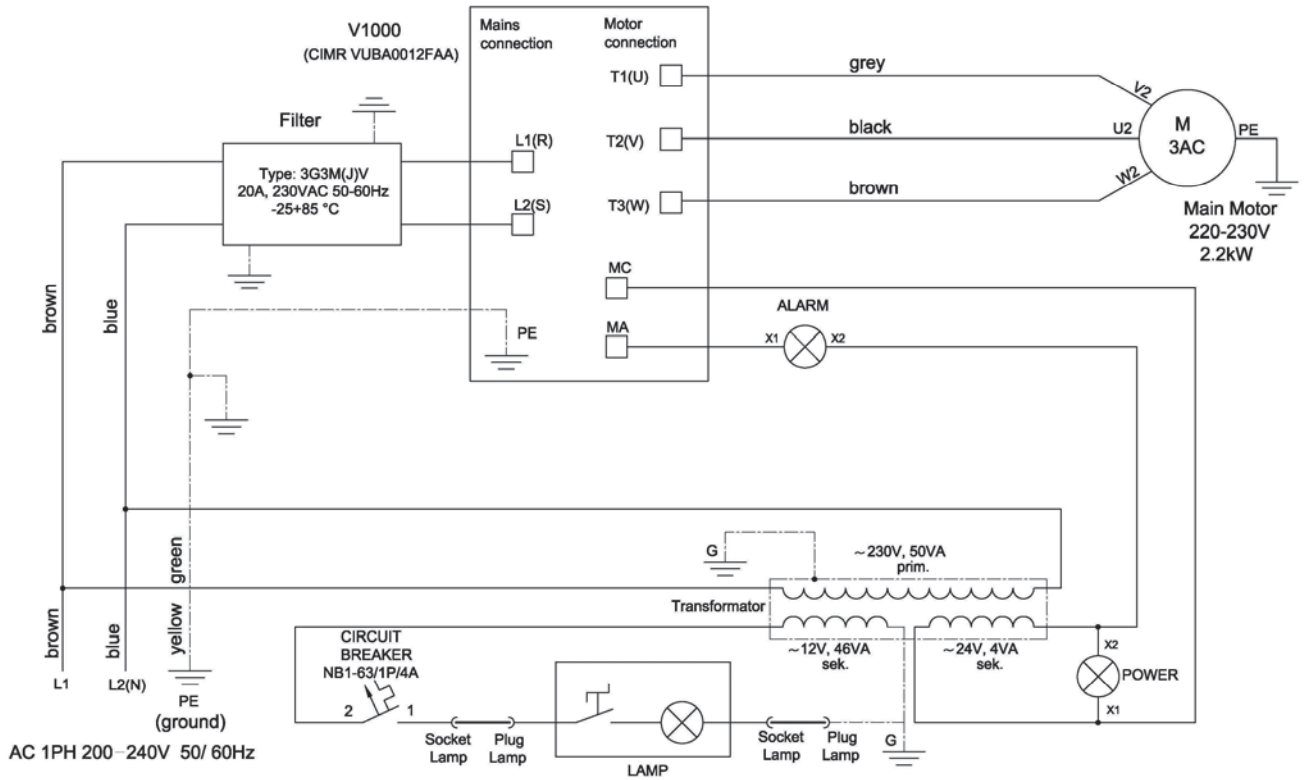
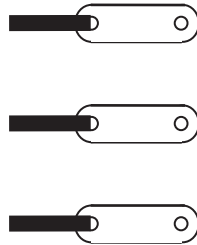

Figure 6.3



The motor is connected in "Delta" (triangle) 230 Volt, reminder for the wire connection of the motor.

Figure 6.4

LAVINA 20 PRO ELECTRICAL SCHEMES YASKAWA CONNECTION MAIN CIRCUIT TERMINALS

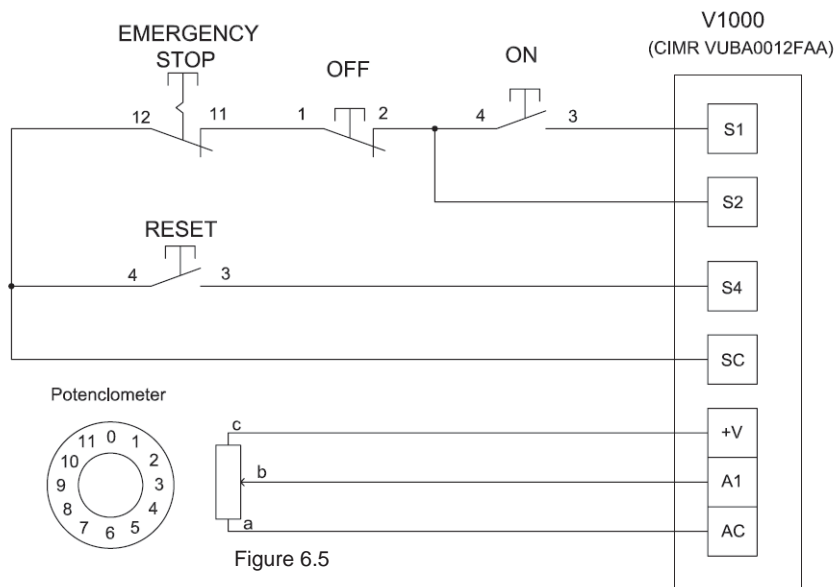

Figure 6.5

Figure 6.5

7. TROUBLESHOOTING

INDEX OF PROBLEMS AND SOLUTIONS

REPLACING POWER CORD AND PLUGS

When replacing the power cord or plugs always use cords and plugs with specifications as the original ones. Never use lower quality or different type cord and plugs.

TENSIONING THE BELTS

PLEASE MAKE SURE YOU CHECK THE TENSION OF THE BELT AFTER THE FIRST 15 HOURS OF OPERATION

If the operator notices, the grinding spindle is turning irregular or noisy or in the worse case, the grinding spindle does not turn although the motor turns. It is recommended to check the belts.

ATTENTION: NEVER "OVER" TENSION THE BELT, THE BELT WILL BE DESTROYED AND IT WILL NEVER RECOVER ITS ORIGINAL TENSION



Figure 7.1



Figure 7.2



Figure 7.3

Unscrew the vacuum port (Fig. 5.1 29) and pull it out (Fig. 7.1, Fig. 7.2). Take off the weight holder (Fig. 5.1 49) together with the guide (Fig. 5.1 48) (Fig. 7.3).



Figure 7.4



Figure 7.5



Figure 7.6

Unscrew the bolts (Fig. 7.4) of the top cover (Fig. 5.1 47) and take it away (Fig. 7.5). Check the tension of the belts (Fig. 7.6). If the belts are damaged or broken; see next chapter "Replacing the Belts" how to replace them.

The Static Belt Tension should be 250 N with a new belt, only 200 N with a used one. It is recommended to use an OPTIKRIK 1 Tension Gauge (Fig. 7.6).



Figure 7.7



Figure 7.8



Figure 7.9

To change the Static Belt Tension, lose the 4 bolts on the motor base (Fig. 5.1 50) (Fig. 7.7). Unsecure the two nuts of the tensioner (Fig. 7.8, Fig. 7.9) Tension by moving the motor closer or wider.



Figure 7.10



Figure 7.11



Figure 7.12

After tensioning secure back the nuts on the tensioner device (Fig. 7.10). When mounting back the top cover (Fig. 5.1 47), see to it the sealer is still in place (Fig. 7.11).

REPLACING THE BELTS



Figure 7.13



Figure 7.14



Figure 7.15

Open the tension device totally (Fig. 7.13). Open up the bottom cover (Fig. 5.1 22) (Fig. 7.14). Remove the belts (Fig. 7.15).



Figure 7.16



Figure 7.17



Figure 7.18

Slide in the new belt through the top cover (Fig. 5.1 47) opening (Fig. 7.16). Put the belt in place by turning the pulleys (Fig. 7.17, Fig. 7.18). Tension like in the chapter “Tensioning the Belts”

MOTOR CONNECTION

In case of changing the motor, please check the cable connection to your motor.

The motor is connected in “Delta” (Triangle) 230 Volt, reminder for the wire connection of the motor.

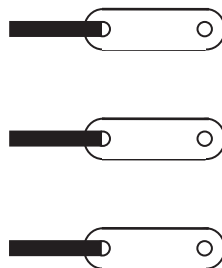

Figure 8.36

FAULT DIAGNOSIS INVERTER YASKAWA V1000

Pages are referring to

Yaskawa Electric SIEP C710606 18A YASKAWA AC Drive – V1000 Technical Manual

◆ Types of Alarms, Faults, and Errors

Check the LED operator for information about possible faults if the drive or motor fails to operate. *Refer to Using the Digital LED Operator on page 70.*

If problems occur that are not covered in this manual, contact the nearest Yaskawa representative with the following information:

- Drive model
- Software version
- Date of purchase
- Description of the problem

Table 6.4 contains descriptions of the various types of alarms, faults, and errors that may occur while operating the drive.

Contact Yaskawa in the event of drive failure.

Table 6.4 Types of Alarms, Faults, and Errors

Type	Drive Responses to Alarms, Faults, and Errors
Faults	<p>When the drive detects a fault:</p> <ul style="list-style-type: none"> • The digital operator displays text that indicates the specific fault and the ALM indicator LED remains lit until the fault is reset. • The fault interrupts drive output and the motor coasts to a stop. • Depending on the setting, the drive and motor may stop via different methods than listed. • If a digital output is programmed for fault output (H2-□□ = E), it will close if a fault occurs. • When the drive detects a fault, it will remain inoperable until that fault has been reset. <i>Refer to Fault Reset Methods on page 264.</i>
Minor Faults and Alarms	<p>When the drive detects an alarm or a minor fault:</p> <ul style="list-style-type: none"> • The digital operator displays text that indicates the specific alarm or minor fault and the ALM indicator LED flashes. • The motor does not stop. • One of the multi-function contact outputs closes if set to be tripped by a minor fault (H2-□□ = 10), but not by an alarm. • The digital operator displays text indicating a specific alarm and ALM indicator LED flashes. • Remove the cause of an alarm or minor fault to automatically reset.
Operation Errors	<p>When parameter settings conflict with one another or do not match hardware settings (such as with an option card), it results in an operation error.</p> <p>When the drive detects an operation error:</p> <ul style="list-style-type: none"> • The digital operator displays text that indicates the specific error. • Multi-function contact outputs do not operate. • When the drive detects an operation error, it will not operate the motor until the error has been reset. Correct the settings that caused the operation error to reset.
Tuning Errors	<p>Tuning errors occur while performing Auto-Tuning.</p> <p>When the drive detects a tuning error:</p> <ul style="list-style-type: none"> • The digital operator displays text indicating the specific error. • Multi-function contact outputs do not operate. • Motor coasts to stop. • Remove the cause of the error and repeat the Auto-Tuning process.

◆ Alarm and Error Displays

■ Faults

When the drive detects a fault, the ALM indicator LEDs remain lit without flashing. If the LEDs flash, the drive has detected a minor fault or alarm. *Refer to Minor Faults and Alarms on page 240* for more information. An overvoltage situation trips both faults and minor faults, therefore it is important to note whether the LEDs remain lit or if the LEDs flash.

LED Operator Display	Name	Page	LED Operator Display	Name	Page
bUS	bUS Option Communication Error	242	CPF08	EEPROM Serial Communications Fault	243
CE	MEMOBUS/Modbus Communication Error	242	CPF11	RAM Fault	243
CF	Control Fault	242	CPF12	FLASH Memory Fault	243
CoF	Current Offset Fault	242	CPF13	Watchdog Circuit Exception	243
CPF02	A/D Conversion Error	242	CPF14	Control Circuit Fault	243
CPF03	PWM Data Fault	243	CPF16	Clock Fault	243
CPF06	Drive specification mismatch during Terminal Board or Control Board replacement	243	CPF17	Timing Fault	243
CPF07	Terminal Board Communication Fault	243	CPF18	Control Circuit Fault	243
			CPF19	Control Circuit Fault	244

LED Operator Display	Name	Page	LED Operator Display	Name	Page		
CPF20 or CPF21	RAM Fault	244	GF	Ground Fault	245		
	FLASH Memory Fault	244	LF	Output Phase Loss	245		
	Watchdog Circuit Exception	244	LF2	Output Open Phase	246		
	Clock Fault	244	oC	Overcurrent	246		
oH3	oH3	Motor Overheat 1 (PTC input)	247	oFA00	oFA00	Option Card Fault (port A)	246
oH4	oH4	Motor Overheat 2 (PTC input)	248	oH	oH	Heatsink Overheat	247
oL1	oL1	Motor Overload	248	oH1	oH1	Heatsink Overheat	247
oL2	oL2	Drive Overload	248	PGo	PGo	PG Disconnect (for Simple V/f with PG)	250
oL3	oL3	Overtorque Detection 1	249	rH	rH	Dynamic Braking Resistor	251
oL4	oL4	Overtorque Detection 2	249	rr	rr	Dynamic Braking Transistor	251
oL5	oL5	Mechanical Weakening Detection 1	249	SEr	SEr	Too Many Speed Search Restarts	251
oL7	oL7	High Slip Braking oL	249	STO	STO	Pull-Out Detection	251
oPr	oPr	Operator Connection Fault	249	UL3	UL3	Undertorque Detection 1	251
CPF22	CPF22	A/D Conversion Error	244	UL4	UL4	Undertorque Detection 2	251
CPF23	CPF23	PWM Feedback Data Fault	244	UL5	UL5	Mechanical Weakening Detection 2	251
CPF24	CPF24	Drive Capacity Signal Fault	244	Uv1	Uv1	Undervoltage	252
dEv	dEv	Excessive Speed Deviation (for Simple V/f with PG)	244	Uv2	Uv2	Control Power Supply Undervoltage	252
EF0	EF0	Option Card External Fault	244	Uv3	Uv3	Soft Charge Circuit Fault	252
EF1 to EF7	EF1 to EF7	External Fault (input terminal S1 to S7)	244	oS	oS	Overspeed (for Simple V/f with PG)	249
FbH	FbH	Excessive PID Feedback	245	ov	ov	Overvoltage	249
FbL	FbL	PID Feedback Loss	245	PF	PF	Input Phase Loss	250

Note: If faults CPF11 through CPF19 occur, the LED operator will display CPF00 or CPF11.

■ Minor Faults and Alarms

When a minor fault or alarm occurs, the ALM LED flashes and the text display shows an alarm code. A fault has occurred if the text remains lit and does not flash. *Refer to Alarm Detection on page 253.* An overvoltage situation, for example, can trigger both faults and minor faults. It is therefore important to note whether the LEDs remain lit or if the LEDs flash.

Table 6.5 Minor Fault and Alarm Displays

LED Operator Display	Name	Minor Fault Output (H2-□□ = 10)	Page	
bb	bb	Drive Baseblock	No output	253
bUS	bUS	Option Card Communications Error	YES	253
CALL	CALL	Serial Communication Transmission Error	YES	253
CE	CE	MEMOBUS/Modbus Communication Error	YES	253
CrSt	CrSt	Can Not Reset	YES	253
dEv	dEv	Excessive Speed Deviation (for Simple V/f with PG)	YES	254
dnE	dnE	Drive Disabled	YES	254
EF	EF	Run Command Input Error	YES	254
EF0	EF0	Option Card External Fault	YES	254
EF1 to EF7	EF1 to EF7	External Fault (input terminal S1 to S7)	YES	255
FbH	FbH	Excessive PID Feedback	YES	255
FbL	FbL	PID Feedback Loss	YES	255
Hbb	Hbb	Safe Disable Signal Input	YES	255
HbbF	HbbF	Safe Disable Signal Input	YES	255
SE	SE	MEMOBUS/Modbus Test Mode Fault	YES	—
oL5	oL5	Mechanical Weakening Detection 1	YES	249
UL5	UL5	Mechanical Weakening Detection 2	YES	251
dWAL	dWAL	DriveWorksEZ Alarm	YES	244
HCA	HCA	Current Alarm	YES	256
oH	oH	Heatsink Overheat	YES	256
oH2	oH2	Drive Overheat	YES	256
oH3	oH3	Motor Overheat	YES	256
oL3	oL3	Overtorque 1	YES	256
oL4	oL4	Overtorque 2	YES	257
oS	oS	Overspeed (for Simple V/f with PG)	YES	257

LED Operator Display		Name	Minor Fault Output (H2-□□ = 10)	Page
<i>ov</i>	ov	Overvoltage	YES	257
<i>PASS</i>	PASS	MEMOBUS/Modbus Test Mode Complete	No output	257
<i>PGo</i>	PGo	PG Disconnect (for Simple V/f with PG)	YES	257
<i>rUn</i>	rUn	During Run 2, Motor Switch Command Input	YES	258
<i>rUnC</i>	rUnC	Run Command Reset	YES	258
<i>UL3</i>	UL3	Undertorque 1	YES	258
<i>UL4</i>	UL4	Undertorque 2	YES	258
<i>Uv</i>	Uv	Undervoltage	YES	258

■ Operation Errors

Table 6.6 Operation Error Displays

LED Operator Display		Name	Page	LED Operator Display		Name	Page
<i>oPE01</i>	oPE01	Drive Unit Setting Error	259	<i>oPE08</i>	oPE08	Parameter Selection Error	260
<i>oPE02</i>	oPE02	Parameter Setting Range Error	259	<i>oPE09</i>	oPE09	PID Control Selection Error	260
<i>oPE03</i>	oPE03	Multi-Function Input Setting Error	259	<i>oPE10</i>	oPE10	V/f Data Setting Error	261
<i>oPE04</i>	oPE04	Terminal Board Mismatch Error	260	<i>oPE11</i>	oPE11	Carrier Frequency Setting Error	261
<i>oPE05</i>	oPE05	Run Command Selection Error	260	<i>oPE13</i>	oPE13	Pulse Train Monitor Selection Error	261
<i>oPE07</i>	oPE07	Multi-Function Analog Input Selection Error	260				

8. WARRANTY AND RETURNS

Warranty Policy for LAVINA® 7 EN Pro

Superabrasive Ltd. guarantees that the original purchaser of the LAVINA® 7 EN Pro machine will be covered against defects in material and workmanship for a period of 2 years from the date of delivery or 500 hours of use whichever comes first.

The following conditions pertain to this warranty:

- Applies only to the original owner and it is not transferable.
- Machine must not be dismantled and tampered with in any way.
- Covered components proven defective will be repaired or replaced at no charge. Covered components include motors, bearings and switches.
- This warranty does not apply to any repair arising from misuse, neglect or abuse, or to repair of proprietary parts.
- This warranty does not apply to products with aftermarket alterations, changes, or modifications.
- This warranty is in lieu of and excludes every condition of warranty not herein expressly set out and all liability for any form of consequential loss or damage is hereby expressly excluded.
- This warranty is limited to repair or replacement of covered components and reasonable labor expenses.
- All warranty returns must be shipped freight prepaid.

The above warranty conditions may be changed only by Superabrasive. Superabrasive reserves the right to inspect and make a final decision on any machine returned under this warranty. This warranty applies to new, used and demo machines.

Superabrasive does not authorize any person or representative to make any other warranty or to assume for us any liability in connection with the sale and operation of our products.

RETURN POLICY FOR LAVINA® 7 EN PRO

LAVINA® 7 EN Pro machines may be returned, subject to the following terms:

In no case, a machine is to be returned to Superabrasive Ltd. for credit or repair without prior authorization. Please contact Superabrasive Ltd. or your local distributor for an authorization and issuance of a return authorization number. This number along with the serial number of the machine must be included on all packages and correspondence. Machines returned without prior authorization will remain property of the sender and Superabrasive Ltd. will not be responsible for these.

9. DISPOSAL

If your machine after time is not usable or needs to be replaced, send the machine back to Superabrasive or a local distributor, where a professional disposal complying with the environment laws and directives is guaranteed.

10. MANUFACTURER'S CONTACTS

If you need to contact Superabrasive Ltd. with technical support questions, below is the contact information.

Address; Superabrasive Ltd.
Rabotnicheska 2A
BG-6140 Krun
Bulgaria

Email: info@superabrasive.us

Tel.: +359 431 6 44 77

Fax: +359 431 6 44 66

Website: www.superabrasive.com