



Click Here To View
Item at

www.GapPower.com

*Sales • Rentals
Parts & Service*

Operator's Instruction Manual

Concrete/Asphalt Saws



Electric, Gasoline and Pneumatic Models



Manual - Portable



READ AND UNDERSTAND THE OPERATORS INSTRUCTION MANUAL *THOROUGHLY* BEFORE ATTEMPTING TO OPERATE THIS EQUIPMENT.



Death or serious injury could occur if this machine is used improperly.



SAFETY MESSAGES

- Safety Instructions are preceded by a graphic alert symbol of DANGER, WARNING, or CAUTION.



Indicates an imminent hazard which, if not avoided, will result in death or serious injury.



Indicates an imminent hazard which, if not avoided, can result in death or serious injury.



Indicates hazards which, if not avoided, could result in serious injury and or damage to the equipment.

GASOLINE/PROPANE POWERED EQUIPMENT



- Engine exhaust from this product contains chemicals known to the State of California to cause cancer, birth defects or other reproductive harm.



- Gasoline is extremely flammable and poisonous. It should only be dispensed in well ventilated areas, and with a cool engine.

- Small gasoline engines produce high concentrations of carbon monoxide (CO) example: a 5 HP 4 cycle engine operation in an enclosed 100,000 cu. ft. area with only one change of air per hour is capable of providing deadly concentrations of CO in less than fifteen minutes. Five changes of air in the same area will produce noxious fumes in less than 30 minutes. Gasoline or propane powered equipment should not be used in enclosed or partially enclosed areas. Symptoms of CO poisoning include, headache, nausea, weakness, dizziness, visual problems and loss of consciousness. If symptoms occur - get into fresh air and seek medical attention immediately.

ELECTRICAL POWERED EQUIPMENT



Extreme care must be taken when operating electric models with water present: Ensure power cord is properly grounded, is attached to a Ground-Fault-Interrupter (GFI) outlet, and is undamaged.

- Check all electrical cables - be sure connections are tight and cable is continuous and in good condition. Be sure cable is correctly rated for both the operating current and voltage of this equipment.
- Improper connection of the equipment-grounding conductor can result in a risk of electric shock. Check with qualified electrician or service person if there is any doubt as to whether the outlet is properly grounded. Adhere to all local codes and ordinances.
- **NOTE:** In the event of a malfunction or breakdown, grounding provides a path of least resistance for the electric current to dissipate. The motor is equipped with a grounded plug and must be connected to an outlet that is properly installed and properly grounded. **DO NOT** modify the plug provided on the motor. If the plug does not fit the outlet have a qualified electrician install the proper receptacle.
- Switch motor **OFF before** disconnecting power.

- Do not disconnect power by pulling cord. To disconnect, grasp the plug, not the cord.
- Unplug power cord at the machine when not in use and before servicing.

GENERAL INSTRUCTIONS

- Equipment should only be operated by trained personnel in good physical condition and mental health (not fatigued). The operator and maintenance personnel must be physically able to handle the bulk weight and power of this equipment.
- This is a one person tool. Maintain a safe operating distance to other personnel. It is the **operators' responsibility** to keep other people (workers, pedestrians, bystanders, etc.) away during operation. Block off the work area in all directions with roping, safety netting, etc. for a safe distance. Failure to do so may result in others being injured by flying debris or exposing them to harmful dust and noise.
- This equipment is intended for commercial use only.
- For the operator's safety and the safety of others, always keep all guards in place during operation.
- Never let equipment run unattended.



- Personal Protection Equipment and proper safety attire must be worn when operating this machinery. The operator must wear approved safety equipment appropriate for the job such as hard hat and safety shoes when conditions require. Hearing protection **MUST** be used (operational noise levels of this equipment may exceed 90db). Eye protection **MUST** be worn at all times.



Keep body parts and loose clothing away from moving parts. Failure to do so could result in dismemberment or death.

- Do not modify the machine.
- Stop motor/engine when adjusting or servicing this equipment.



Maintain a safe operating distance from flammable materials. Sparks from the cutting-action of this machine can ignite flammable materials or vapors.

DUST WARNING



Some dust created by power sanding, sawing, grinding, drilling, and other construction activities contains chemicals known to cause cancer, birth defects, or other reproductive harm. Some examples of these chemicals are:

- Lead from lead-based paints, and
- Crystalline silica from bricks and concrete and other masonry products.

Your risk of exposure to these chemicals varies depending on how often you do this type of work. To reduce your risk: work in a well ventilated area, use a dust control system, such as an industrial-style vacuum, and wear approved personal safety equipment, such as a dust/particle respirator designed to filter out microscopic particles.

Operators Instruction Manual

Table of Contents

<u>Section</u>	<u>Page Number</u>
Operating Controls.....	4
Operating Instructions.....	5-7
Optional Accessories.....	7
Maintenance Instructions.....	8
Changing Blades.....	9
Lubrication Points.....	10
Maintenance Schedule.....	11
Limited Equipment Warranty.....	Back Page

Note:
All dimensions, views
& weights are for
reference only
and subject to change at
any time.

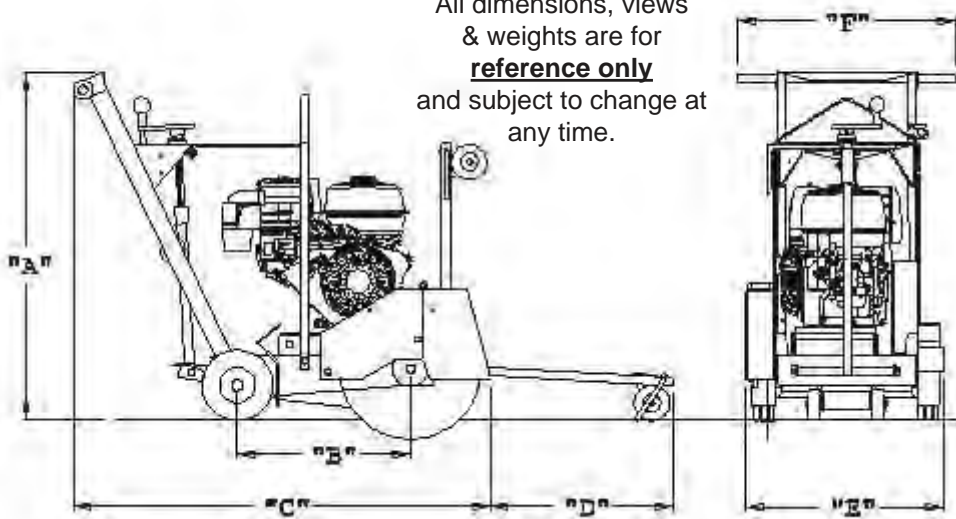

Figure 1

HOW TO ORDER REPAIR PARTS

To insure product safety and reliability, always use genuine EDCO replacement parts when making repairs to the equipment.

When ordering parts, please specify the MODEL and SERIAL NUMBER of the machine as given on the NAMEPLATE. In addition, give part number, description and quantity as listed on the parts list.

Please note: Due to improvements and changes in the equipment the illustrations shown may be different from the actual machine.

Toll Free: Phone 1-800-638-3326 • Fax 1-800-447-3326

Model #	DS-18	SK-14	SB-14	ASB-14	SK-10
"A"	39 3/8"	38"	37"	37"	35"
"B"	48 3/4"	16 1/2"	17 3/4"	17 3/4"	15"
"C"	----	48"	48 3/4"	48 3/4"	41"
"D"	20 1/2"	14 3/4"	14 1/2"	14 1/2"	N/A
"E"	----	22"	21 1/2"	21 1/2"	15 1/2"
"F"	254 lbs.	23 1/2"	23 1/2"	23 1/2"	17"
Weight		173 lbs.	180 lbs.	160 lbs.	153 lbs.



100 Thomas Johnson Drive, Frederick, MD 21702-4600 USA
 Phone (301) 663-1600 • 1-800-638-3326
 Fax (301) 663-1607 • 1-800-447-3326
 Website: www.edcoinc.com
 Email: sales@edcoinc.com

Printed in USA
 ©2007
Page 3

Operating Controls

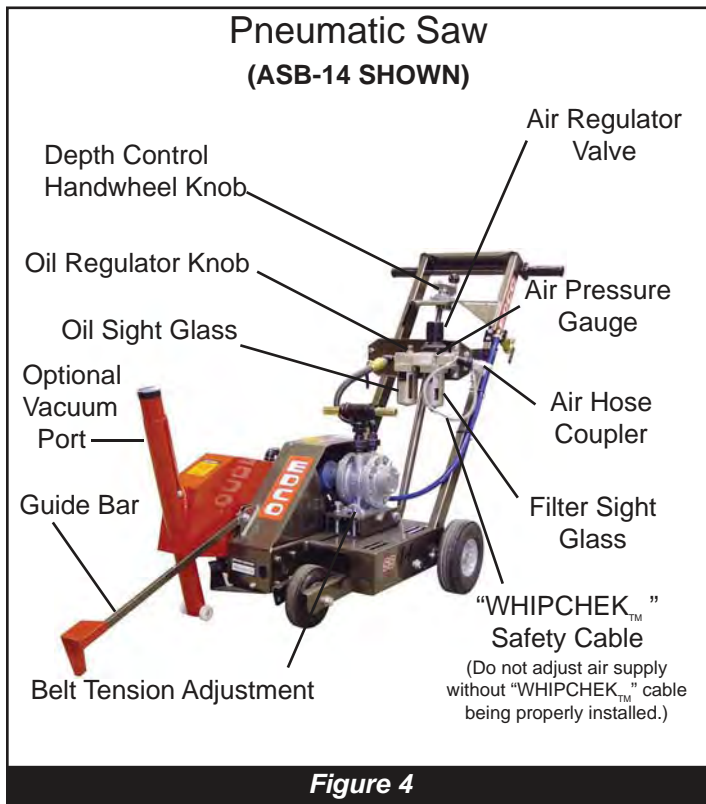
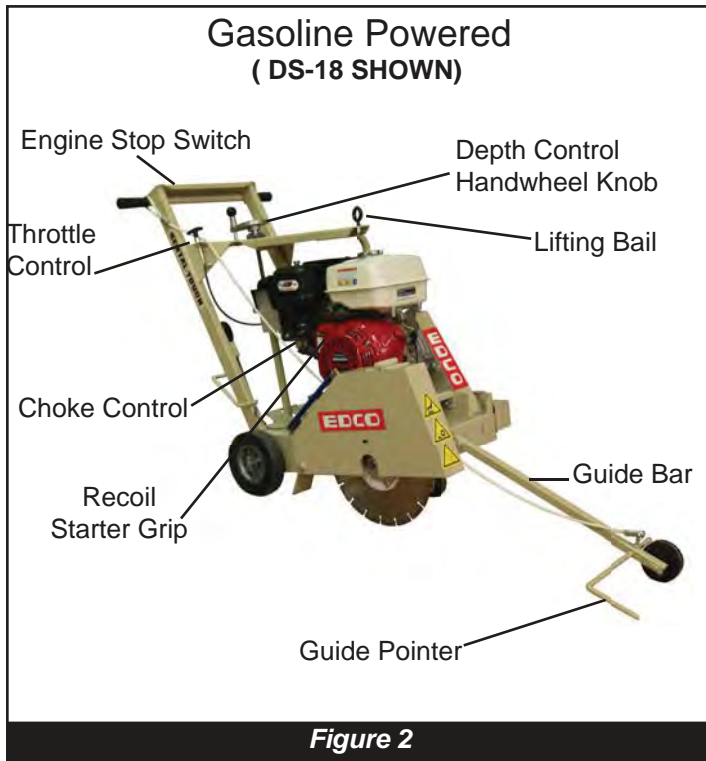

Please Note:

Controls shown are for the model indicated.

The location of these controls may vary on the different models.

Due to improvements and changes in the equipment, the illustration shown may be different from the actual machine.

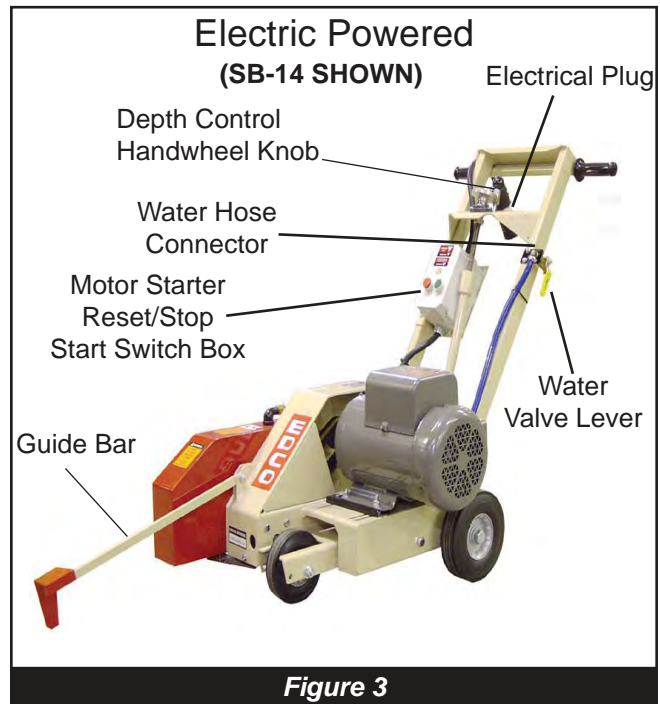

Operating Instructions



- Read and understand all operating instructions before operating this equipment. Death or serious injury can result if this machine is used improperly.
- Concrete saws are designed to be used to cut flat horizontal concrete or asphalt slabs using diamond saw blades.
- The machines may be equipped with gasoline engines or electric motors.
- They are designed to be controlled by a single operator from a position at the rear of the saw.
- Maintain a safe distance from other personnel in the area.

Be sure to read the Rx for Concrete Saws supplied with your machine.

IMPORTANT: Perform Pre-Start Check.

- Visually inspect the equipment for wear or damage.
- Be sure all guards are in place and functioning properly. Do not operate unless blade guard is in place and secure.
- Perform all daily maintenance.
- Check to be sure water tubes are functioning properly if performing wet-cutting operations.
- Inspect blade - Be sure the correct blade is installed properly on the machine, including RPM, size, mounting arrangement and its intended use.
- Check blade for damage (see *Figure 5*, below).
- Inspect work area to determine the presence and location of deck inserts, pipes, columns and objects protruding from the slab surface so that they may be avoided during the cutting operation. Scribe a line to help guide the saw.

Possible Diamond Blade Problems

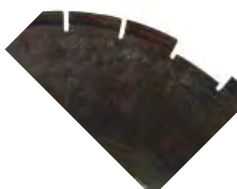

Segment Loss:
Usually insufficient
water

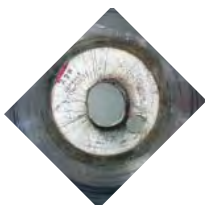

Arbor Hole
Out-Of -Round
Blade not properly tightened
or seated on arbor



Cracked Segments
and/or Core
Wrong Blade for the job

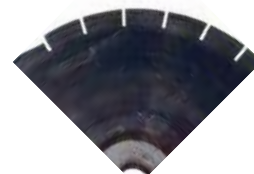

Blade Will Not Cut:
Blade is glazed or
to hard for the job

Figure 5



A Division of Equipment Development Company, Inc.

100 Thomas Johnson Drive, Frederick, MD 21702-4600 USA
Phone (301) 663-1600 • 1-800-638-3326
Fax (301) 663-1607 • 1-800-447-3326
Website: www.edcoinc.com
Email: sales@edcoinc.com

Printed in USA

©2007

Page 5

Operating Instructions

- **FOR WET CUTTING:** Attach the water supply. A flow rate of approximately 2 gallons per minute (minimum) is required. Attach the water hose to the coolant valve. Use the valve to control the flow of water.
- **FOR DRY CUTTING:** Provide a respirator and dust control system.
- **FOR ELECTRIC MODELS:** Be sure the “OFF” button is depressed. Hook up the electrical power source by plugging into the connector provided. If the cord does not mate with the connector, consult a qualified licensed electrician before continuing. Be sure that the equipment is properly grounded.
- **FOR GASOLINE MODELS:** Put the engine stop switch in the “RUN” position. Consult the engine manufacturers operating instructions and follow the directions for starting and breaking in the engine.
- **FOR PNEUMATIC MODELS:** Before connecting the air source, be sure the “WHIPCHECK™” cable is properly installed and the flow control lever is in the “OFF” position. Adjust the air pressure to 90 psi (100 psi MAX.) using the air regulator valve (*see Figure 4 on page 4*). Open the flow control lever gradually to start and adjust the oil regulator knob as required for your application.

-
- **BEFORE STARTING THE ENGINE OR MOTOR:** Raise the saw blade clear of the working surface. The blade is raised using the depth control handwheel knob mounted on the upper handle assembly (*Figure 6*). Lift the knob to unlock and turn the handwheel clockwise until the blade is clearly off the ground.
 - **START ENGINE AND ALLOW IT TO REACH OPERATING SPEED.** Position the saw over the cutting line. Bring the engine to full speed. Lower the blade into the slab surface by slowly turning the depth control handwheel knob. NOTE - the 14 inch blade has a maximum cutting depth of 4 3/4". Do not allow the arbor flanges to contact slab surface.

When the selected cutting depth is reached, lock the depth control handwheel knob and proceed to push the saw forward. The saw blade must remain straight, do not twist, and do not force blade, the engine or motor should not strain when cutting.

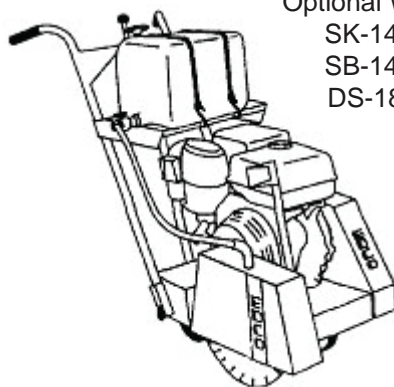

Figure 6

Operating Instructions

- **TO STOP THE MACHINE:** Stop forward motion. On gasoline models push the throttle to idle. Turn the depth control handwheel knob counter clockwise to raise the blade clear of the cut. Turn ignition or power switch off and let the engine come to a complete stop. Turn off the water supply.
- **WHEN MANEUVERING THE SAW:** Make sure the blade is raised high enough so it does not strike the slab surface. Damage to blade may occur with inadvertent contact with the slab or other object.
- **DO NOT FORCE BLADE WHILE CUTTING.**
- **IF THE POWER SOURCE STALLS IN THE CUT:** Raise the blade completely out of the cut. Disconnect the power source (i.e. the spark plug wire on a gasoline engine or disconnect an electric model at the machine). Inspect the blade flange nut/bolt to verify that they are still tight, and inspect the blade for damage. Replace damaged (or questionable) blades immediately.
- **WHEN TRANSPORTING THE SAW:** Be sure to remove the blade. Before removing the blade, disconnect the power source before lifting or removing any guard. See the directions for Changing Blades on *(page 9)*.
- **WHEN HOISTING A CONCRETE SAW EQUIPPED WITH A LIFTING BAIL:** Always inspect frame and attaching hardware for damage before lifting. Use proper safe hoisting techniques and hardware.

Optional Accessories



Optional Water Tank Kit for
SK-14 (P/N 52030),
SB-14 (P/N 51090),
DS-18 (P/N 56310)

Model SK-14, with WaterTank Option, shown

Figure 7

Maintenance Instructions



Disconnect the machine from the power source. Remove the spark plug lead on gasoline engine models or disconnect the supply voltage connector on electric models, before performing any maintenance. All maintenance to be performed regularly by qualified personnel.

- Never work under saw without first placing chocks on the wheels and support device under the saw to prevent it from moving or falling. Always work on a flat and level surface.
- Refer to the engine manual for maintenance information specific to the engine used. Be sure to check oil level before operation. Clean air filter element daily.
- Grease bearings after every 4 hours of use. Refer to **(page 10)** for lubrication points on available models.
- Perform a visual inspection of the entire machine before operation. Be sure all fasteners are tight and secure, check for signs of metal cracking or fatigue, inspect for damage to electrical wiring, damage to fuel lines, check bearings and inspect to be sure proper guards are in place and secure, etc...
- Inspect belts before operation. Check belt tension. On new equipment, belts should be re-tensioned after the first four hours of use. Damaged, stretched or excessively worn belts should be replaced with a new matched set.
- To tension belts, loosen motor mounting hardware slightly. Either push motor towards the rear of the saw (handle bar side) until the belts are tight or on the models with a belt tensioning adjustment bolt, use bolt to adjust the motor until the belts are tight. Re-torque the engine mounting hardware **(see Figure 8 below)**.
- Proper belt tension must be maintained to transmit the engine power to the cutting blade. Slipping belts will over-heat, the blade life will be shortened and the cutting speed limited. Over tensioned belts will shorten the belt and bearing life.
- Check diamond blades for cracks, loose segments and oversize, worn, or out-of-round arbor holes **(See Figure 5 on page 5)**. Do not use **any** questionable blade since serious injury and/or damage to property can result. Do not use warped, twisted, or out-of-balance blades. Unbalanced blades will wear excessively, vibrate and damage both arbor shaft and bearings. Do not use a blade without a drive pinhole **(Figure 9)**.
- For safety reasons, EDCO **does not** recommend the use of any abrasive blades. Abrasive blades can break and cause serious personal injury to operator and/or bystanders. If abrasive blades are used by choice, use only reinforced abrasive blades. Inspect abrasive blades carefully.
- Be sure arbor shaft, backing plate and blade cap are clean and in good condition. Flanges should be free of nicks and burrs. Replace if out-of-round or worn.

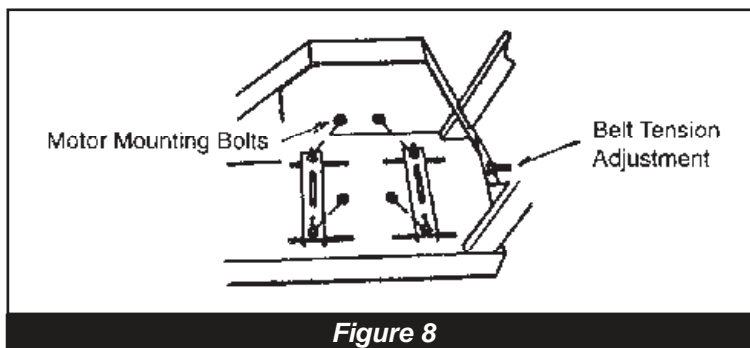

Figure 8

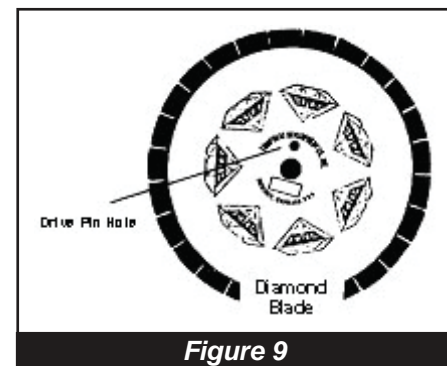

Figure 9

Changing Blades (On EDCO saws listed in this manual)



Disconnect the machine from the power source before performing any work on the equipment (i.e. changing the blade). To disconnect the power source on gasoline engine models, remove the spark plug lead. On electric models, unplug the electrical power cord at the machine.

- Make sure you have the proper blade for the job. Determine the hardness and composition of the slab. Give your dealer complete information including whether re-bars are present, the desired depth of the cut, and the length of the cut. If in doubt, contact the blade manufacturer.



Inspect the blades before installing. Check diamond blades for cracks, loose segments and oversize, worn, or out-of-round arbor holes (**Figure 5 on page 5**). Do not use any questionable blade since serious personal injury and/or damage to property can result. Do not use warped, twisted, or out-of-balance blades. Unbalanced blades will wear excessively, vibrate and damage both arbor shaft and bearings. Do not use a blade without a drive pinhole (**Figure 9**).



For safety reasons, EDCO **does not** recommend the use of any abrasive blades. Abrasive blades can break and cause serious personal injury to operator and/or bystanders. If abrasive blades are used by choice, use only reinforced abrasive blades. Inspect abrasive blades carefully.



Never exceed the maximum operating speed of the blade. Be sure to match the blade speed rating with the arbor shaft speed on the machine. The standard models of the SK-14, SB-14, DS-18 have an arbor shaft speed (unloaded) of 3600 RPM and 3000 RPM under load.

- Do not remove or lift the bladeguard unless machine is stopped and all power is disconnected. Be sure to re-install blade guard before reconnecting the power source.
- Be sure the arbor shaft, backing plate, and blade cap are clean and in good condition. Make sure the threads are clean and undamaged. If any damage is detected, consult your EDCO dealer (or the EDCO factory).
- The backing plate and blade cap (**Figure 10**) should be the same diameter, do not use if they are different diameters. For abrasive blades and for all steel centered diamond blades, the backing plate and blade cap must be at least 1/4 the diameter of the blade.
- The drive pin should be tight in blade cap and long enough to fit through blade and into hole in backing plate.
- Place the blade on the arbor shaft and turn until the drive pinhole lines up with the backing plate.
- Place the blade cap on the arbor shaft so the drive pin goes through the holes in the blade and backing plate.
- Put on washer and arbor shaft nut and tighten arbor shaft nut.
- Secure the blade guard in the operating position before reconnecting the power supply or starting engine.

Optional:

CE models are equipped with electrical interlocks. Blade guards and/or arbor guards must be in place and secured before these engines can be started.

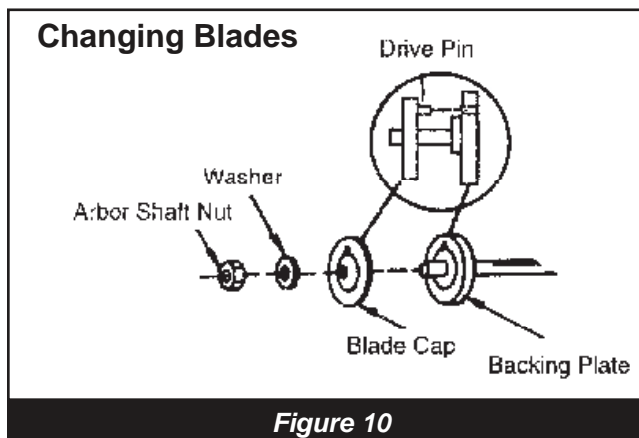

Figure 10



A Division of Equipment Development Company, Inc.

100 Thomas Johnson Drive, Frederick, MD 21702-4600 USA
 Phone (301) 663-1600 • 1-800-638-3326
 Fax (301) 663-1607 • 1-800-447-3326
 Website: www.edcoinc.com
 Email: sales@edcoinc.com

Printed in USA

©2007

Page 9

Lubrication Points

Grease Bearings Every 4 Hours of Use

NOTE: Wipe grease fittings clean before servicing.

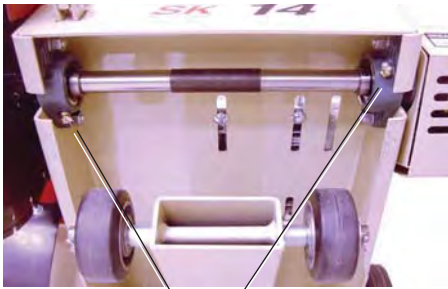

GREASE FITTINGS

MODEL SK-14



GREASE FITTINGS

MODEL SK-10



GREASE FITTINGS

MODEL SB-14
ASB-14

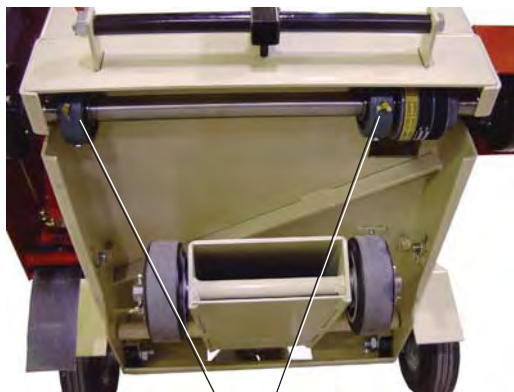

GREASE FITTINGS

MODEL DS-18





Repairs are to be performed by EDCO or by approved EDCO repair technicians.



Read and follow all instructions in the Engine Manufacturer's Owner's Manual.

Maintenance Schedule

	Before Operation	Every 4 Hours	Daily	Every 50 Hours of Operation	As Required
Visual Inspection of Entire Machine	X				
Check Engine Oil*	X				
Change Engine Oil* (refer to Engine manual)				X	
Clean Air Filter Element*			X		
Grease Bearings		X			
Inspect Drive Belts	X				
Inspect Blade	X				
Belt Tensioning					X
Inspect Arbor Shaft	X				

*Gasoline Models Only

LIMITED EQUIPMENT WARRANTY OF SALE – TERMS & CONDITIONS

Equipment Development Company, Inc. herein referred to as EDCO (Seller) warrants that each new unit manufactured by EDCO to be free from defects in material and workmanship in normal use and service for a period of (1) one year (except for the cutter drum assembly on all model concrete/asphalt planes, in which case the warranty period shall be 90 days) from date of shipment to the original retail or equipment rental center owner.

Accessories or equipment furnished and installed on the product by EDCO but manufactured by others, including, but not limited to engines, motors, electrical components, transmissions etc., shall carry the accessory manufacturers own warranty.

EDCO will, at its option, repair or replace, at the EDCO factory or at a point designated by EDCO, any part which shall appear to the satisfaction of EDCO inspection to have been defective in material or workmanship.

EDCO reserves the right to modify, alter and improve any part or parts without incurring any obligation to replace any part or parts previously sold without such modified, altered or improved part or parts.

This warranty is in lieu of and excludes all other warranties, expressed, implied, statutory, or otherwise created under applicable law including, but not limited to the warranty of merchantability and the warranty of fitness for a particular purpose in no event shall seller or the manufacturer of the product be liable for special, incidental, or consequential damages, including loss of profits, whether or not caused by or resulting from the negligence of seller and/or the manufacturer of the product unless specifically provided herein. In addition, this warranty shall not apply to any products or portions there of which have been subjected to abuse, misuse, improper installation, maintenance, or operation, electrical failure or abnormal conditions and to products which have been tampered with, altered, modified, repaired, reworked by anyone not approved by seller or used in any manner inconsistent with the provisions of the above or any instructions or specifications provided with or for the product

FORCE MAJEURE

Seller's obligation hereunder are subject to, and Seller shall not be held responsible for, any delay or failure to make delivery of all or any part of the Product due to labor difficulties, fires, casualties, accidents, acts of the elements, acts of God, transportation difficulties, delays by a common carrier, inability to obtain Product, materials or components or qualified labor sufficient to timely perform part of or all of the obligations contained in these terms and conditions, governmental regulations or actions, strikes, damage to or destruction in whole or part of manufacturing plant, riots, terrorist attacks or incidents, civil commotions, warlike conditions, flood, tidal waves, typhoon, hurricane, earthquake, lightning, explosion or any other causes, contingencies or circumstances within or without the United States not subject to the Seller's control which prevent or hinder the manufacture or delivery of the Products or make the fulfillment of these terms and conditions impracticable. In the event of the occurrence of any of the foregoing, at the option of Seller, Seller shall be excused from the performance under these Terms and Conditions, or the performance of the Seller shall be correspondingly extended.

This document sets forth the terms and conditions pursuant to which the purchaser ("Purchaser") will purchase and Equipment Development Co.Inc. ("Seller") will sell the products, accessories, attachments (collectively the Products ") ordered by the Purchaser. These terms and conditions shall govern and apply to the sale of Seller's Products to Purchaser, regardless of any terms and conditions appearing on any purchase order or other forms submitted by Purchaser to Seller, or the inconsistency of any terms therein and herein.

1. PRICE

All prices set forth on any purchase order or other document are F.O.B. Sellers facility or distribution point, as may be determined by Seller (F.O.B.Point). All prices are exclusive of any and all taxes, including, but not limited to, excise, sales, use, property or transportation taxes related to the sale or use of the Products, now or hereafter imposed, together with all penalties and expenses. Purchaser shall be responsible for collecting and/or paying any and all such taxes, whether or not they are stated in any invoice for the Products. Unless otherwise specified herein, all prices are exclusive of inland transportation, freight, insurance and other costs and expenses relating to the shipment of the Products from the F.O.B. point to Purchaser's facility. Any prepayment by Seller of freight insurance and other costs shall be for the account of Purchaser and shall be repaid to Seller.

2. PAYMENT TERMS

Payment terms are as follows. 2% 10 days (to approved and qualified accounts). Net 30 days. This is a cash discount for invoices paid within 10 days after the invoice date, regardless of date of receipt of shipment. This is not a trade discount and will not be granted to accounts that do not adhere to stated terms.

*All past due accounts are subject to a late payment fee of 1.5% per month or a maximum allowed by law if different, along with the expenses incidental to collection including reasonable attorney's fees and costs.

*Seller reserves the right to hold shipments against past due accounts.

*Seller reserves the right to alter payment terms.

3. FREIGHT TERMS

All shipments will be made F.O.B. shipping point as designated in these Terms and Conditions, and title shall pass at the F.O.B. point. Delivery to the initial common carrier shall constitute delivery to the Purchaser. Any claims for loss or damage during shipment are to be filed with carrier by the Purchaser. Seller will not assume responsibility for the performance of the carrier.

Back orders will be shipped in the most practical fashion with charges consistent with our freight policy established with the original order. UPS, FED EX, MAIL or shipments by other couriers are subject to the same terms and conditions as outlined in paragraph #3"Freight Terms".

4. DELIVERY, DAMAGES, SHORTAGES

Seller shall use reasonable efforts to attempt to cause the Products to be delivered as provided for in these Terms & Conditions. Delivery to the initial common carrier shall constitute the delivery to the Purchaser. Sellers responsibility, in so far as transportation risks are concerned ceases upon the delivery of the Products in good condition to such carrier at the F.O.B. point and all the Products shall be shipped at the Purchaser's risk. Seller shall not be responsible or liable for any loss of income and/or profits, or incidental, special, consequential damages resulting from Seller's delayed performance in shipment and delivery.

5. RETURN OF DEFECTIVE PPRODUCTS

Defective or failed material shall be held at the Purchaser's premises until authorization has been granted by Seller to return or dispose of Products. Products that are to be returned for final inspection must be returned Freight Prepaid in the most economical way. Credit will be issued for material found to be defective upon Seller's inspection based on prices at time of purchase.

6. PRODUCTS ORDERED IN ERROR

Products may be returned, provided that claim is made and Seller is notified within 7 days of receipt of Products, and the Products are in original buyer's possession not more than 30 days prior to return, subject to Seller's approval. If Products are accepted for return, they must be Freight Prepaid and buyer will be charged a minimum of 15% rehandling charge, plus a charge back for outbound freight charges if the original order was shipped prepaid. Returns are not accepted for any Products that are specifically manufactured to meet the buyer's requirement of either specifications or quantity.

AGREEMENTS

These Terms and Conditions constitute the entire agreement between Seller and Purchaser as it relates to terms and conditions of sale, and supersedes any and all prior oral or written agreements, correspondence, quotations or understandings heretofore in force between the parties relating to the subject matter hereof. There are no agreements between Seller and Purchaser with respect to the Product herein except those specifically set forth in and made part of these terms and conditions. Any additional terms, conditions and/or prices are rejected by Seller.

These terms and conditions may be modified, cancelled or rescinded only by a written agreement of both parties executed by their duly authorized agents.

USE ONLY GENUINE EDCO PARTS & ACCESSORIES
For your own safety, the safety of others and the life of your machine.

