

# SELF-PROPELLED SCISSOR LIFTS

## OPERATOR'S MANUAL

*with Maintenance Information*

**DSL-40**



### WARNING

THE MANUFACTURER SHALL NOT BE HELD LIABLE IN CASE OF FAULTS OR ACCIDENTS DUE TO NEGLIGENCE, INCAPACITY, INSTALLATION BY UNQUALIFIED TECHNICIANS AND IMPROPER USE OF THE MACHINE

DO NOT OPERATE THIS MACHINE UNTIL YOU READ AND UNDERSTAND ALL THE DANGERS, WARNINGS AND CAUTIONS IN THIS MANUAL

Part Number: SM0114113

**ANSI**

Ballymore Company, Inc.  
Zhejiang Dingli Machinery Co., Ltd.

Second Edition, January 2016 Printing

# Version of the Record

## Version of the Record

Version Number	Create Date
SM0114113_Rev1.0 .....	2014-12
SM0114113_Rev2.0 .....	2015-10



## Important

Read, understand and obey these safety rules and operating instructions before operating this machine.

Only trained and authorized personnel shall be permitted to operate this machine. This manual should be considered a permanent part of your machine and should remain with the machine at all times. If you have any questions, please call BALLYMORE INC.

## Contents

---

	Page
Safety Rules	1
Legend	8
Decals	9
Specifications	13
Control panel	14
Pre-operation Inspection	17
Workplace Inspection	19
Function Tests	20
Operating Instructions	24
Transport and Lifting Instructions	34
Maintenance	38
Schematic	65
Inspection and Repair Log	67

---

## Owners, Users and operators:

We appreciate your choice of our machine for your application. Our number one priority is user safety, which is best achieved by our joint efforts. We feel that you make a major contribution to safety if you, as the equipment users and operators:

- 1 Comply with employer, job site and governmental rules.
- 2 Read, understand and follow the instructions in this and other manuals supplied with this machine.
- 3 Use good safe work practices in a commonsense way.
- 4 Only have trained / certified operators, directed by informed and knowledgeable supervision, running the machine.

If there is anything in this manual that is not clear or which you believe should be added, please contact us.

---

## Contact us:

---

### Ballymore Compnay

501 Gunnard Carlson Dr.

Coatesville, PA 19320

Tel: 1-800-762-8327

Fax: 1-610-593-8615

Web: [www.ballymore.com](http://www.ballymore.com)



## Safety Rules



### Danger

Failure to obey the instructions and safety rules in this manual will result in death or serious injury.

### Do Not Operate Unless:

- You learn and practice the principles of safe machine operation contained in this operator's manual.
  - 1 Avoid hazardous situations.**
  - Know and understand the safety rules before going on to the next section.**
  - 2 Always perform a pre-operation inspection.
  - 3 Always perform function tests prior to use.
  - 4 Inspect the workplace.
  - 5 Only use the machine as it was intended.
- You read, understand and obey the manufacturer's instructions and safety rules— safety and operator's manuals and machine decals.
- You read, understand and obey employer's safety rules and worksite regulations.
- You read, understand and obey all applicable governmental regulations.
- You are properly trained to safely operate the machine.

### Decal Legend

BALLYMORE/DINGLI product decals use symbols, color coding and signal words to identify the following:



**Safety alert symbol** — used to alert personnel to potential personal injury hazards. Obey all safety messages that follow this symbol to avoid possible injury or death.



**DANGER** Red — used to indicate the presence of an imminently hazardous situation which, if not avoided, will result in death or serious injury.



**WARNING** Orange — used to indicate the presence of a potentially hazardous situation which, if not avoided, could result in death or serious injury.



**CAUTION** Yellow with safety alert symbol — used to indicate the presence of a potentially hazardous situation which, if not avoided, may cause minor or moderate injury.



**NOTICE** Blue without safety alert symbol — used to indicate the presence of a potentially hazardous situation which, if not avoided, may result in property damage.

## Safety Rules

### Intended Use

This machine is intended to be used only to lift personnel, along with their tools and materials to an aerial work site.

### Safety Sign Maintenance

Replace any missing or damaged safety signs. Keep operator safety in mind at all times. Use mild soap and water to clean safety signs. Do not use solvent-based cleaners because they may damage the safety sign material.

#### **⚠ Electrocution Hazard**

This machine is not electrically insulated and will not provide protection from contact with or proximity to electrical current.

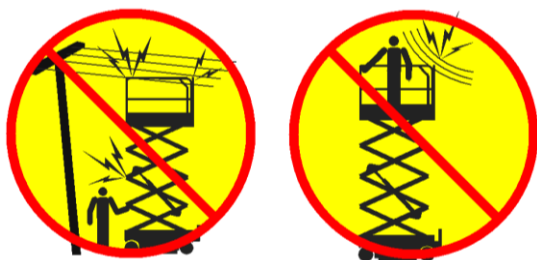

Maintain safe distances from electrical power lines and apparatus in accordance with applicable governmental regulations and the following chart.

Voltage Phase to Phase	Minimum Safe Approach Distance	
0 to 300V	Avoid Contact	
300V to 50kV	10ft	3.05m
50kV to 200kV	15ft	4.60m
200kV to 350kV	20ft	6.10m
350kV to 500kV	25ft	7.62m
500kV to 750kV	35ft	10.67m
750kV to 1000kV	45ft	13.72m

Allow for platform movement, electrical line sway or sag and beware of strong or gusty winds.

Keep away from the machine if it contacts energized power lines. Personnel on the ground or in the platform must not touch or operate the machine until energized power lines are shut off.

Do not operate the machine during lightning or storms.

Do not use the machine as a ground for welding.

#### **⚠ Tip-over Hazard**

Occupants, equipment and materials must not exceed the maximum platform capacity or the maximum capacity of the platform extension.

#### **Maximum capacity – DSL-40**

Maximum occupants 2

Platform allowable maximum load 550 lbs/250 kg

Extension deck allowable maximum load 250 lbs/113 kg

Platform retracted



Platform extended



Extension only      Platform only





## Safety Rules

Do not push the machine or other objects with the platform.

Do not operate the machine with the chassis trays open.

Do not contact adjacent structures with the platform

Do not alter or disable the limit switches.

Do not tie the platform to adjacent structures.

Do not place loads outside the platform perimeter.



Do not alter or disable machine components that in any way affect safety and stability.

Do not replace items critical to machine stability with items of different weight or specification.

Do not use batteries that weigh less than the original equipment. Batteries are used as counterweight and are critical to machine stability. Each battery must weigh 82 lbs / 37 kg. The batteries must weigh a minimum of 328 lbs / 148 kg

Do not modify or alter an aerial work platform without prior written permission from the manufacturer. Mounting attachments for holding tools or other materials onto the platform, toe boards or guard rail system can increase the weight in the platform and the surface area of the platform or the load.

Do not place ladders or scaffolds in the platform or against any part of this machine.

Do not transport tools and materials unless they are evenly distributed and can be safely handled by person(s) in the platform.

Do not use the machine on a moving or mobile surface or vehicle.

Be sure all tires are in good condition, air-filled tires are properly inflated and lug nuts are properly tightened.

### ▲ Crushing Hazard

Keep hands and limbs out of scissors.

Keep hands clear when folding rails.

Use common sense and planning when operating the machine with the controller from the ground. Maintain safe distances between the operator, the machine and fixed objects.

Maintain a firm grasp on the platform rail when removing the rail pins. Do not allow the platform guard rails to fall.

### ▲ Operation on Slopes Hazard

Do not drive the machine on a slope that exceeds the slope and side slope rating of the machine.

Slope rating applies to machines in the stowed position.



Maximum slope rating stowed

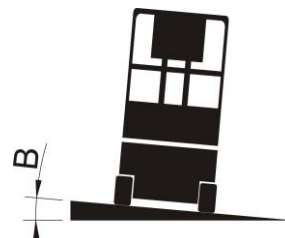

Maximum side slope rating stowed

DSL-40	25% (14°)	5°



## Safety Rules



Limit travel speed according to the condition of the ground surface, congestion, slope, location of personnel, and any other factors which may cause collision.

### ⚠ Component Damage Hazard

Do not use any battery charger greater than 24V to charge the batteries.

Do not use the machine as a ground for welding.

### ⚠ Explosion and Fire Hazard

Do not operate the machine or charge the batteries in hazardous locations where potentially flammable or explosive gases or particles may be present.

### ⚠ Damaged Machine Hazard

Do not use a damaged or malfunctioning machine.

Conduct a thorough pre-operation inspection of the machine and test all functions before each work shift. Immediately tag and remove from service a damaged or malfunctioning machine.

Be sure all maintenance has been performed as specified in this manual. Be sure all decals are in place and legible.

Be sure the operator's manual is complete, legible and in the storage container located in the platform.

### ⚠ Bodily Injury Hazard

Do not operate the machine with a hydraulic oil or air leak. An air leak or hydraulic leak can penetrate and/or burn skin.

Improper contact with components under any cover will cause serious injury. Only trained maintenance personnel should access compartments. Access by the operator is only advised when performing a pre-operation inspection. All compartments must remain closed and secured during operation.

### ⚠ Battery Safety

#### ⚠ Burn Hazard



Batteries contain acid. Always wear protective clothing and eye wear when working with batteries.

Avoid spilling or contacting battery acid. Neutralize battery acid spills with baking soda and water.

### ⚠ Explosion Hazard



Keep sparks, flames and lighted tobacco away from batteries. Batteries emit explosive gas.

The battery tray should remain open during the

## Safety Rules

entire charging cycle.

Do not contact the battery terminals or the cable clamps with tools that may cause sparks.

### ▲ Component Damage Hazard

Do not use any battery charger greater than 24V to charge the batteries.

### ▲ Electrocutation/ Burn Hazard



Connect the battery charger to a grounded, AC 3-wire electrical outlet only.

Inspect daily for damaged cords, cables and wires.

Replace damaged items before operating.

Avoid electrical shock from contact with battery terminals. Remove all rings, watches and other jewelry.

### ▲ Tip-over Hazard

Do not use batteries that weigh less than the original equipment. Batteries are used as counterweight and are critical to machine stability. Each battery must weigh 82 lbs / 37 kg. The batteries must weigh a minimum of 328 lbs / 148 kg.

### ▲ Lifting Hazard

Use the appropriate number of people and proper lifting techniques when lifting batteries.

## Lockout after Each Use

- 1 Select a safe parking location - firm level surface, clear of obstruction and traffic.
- 2 Lower the platform.
- 3 Turn the key switch to the off position and remove the key to secure from unauthorized use.
- 4 Chock the wheels.
- 5 Charge the batteries.

# Legend

## Legend

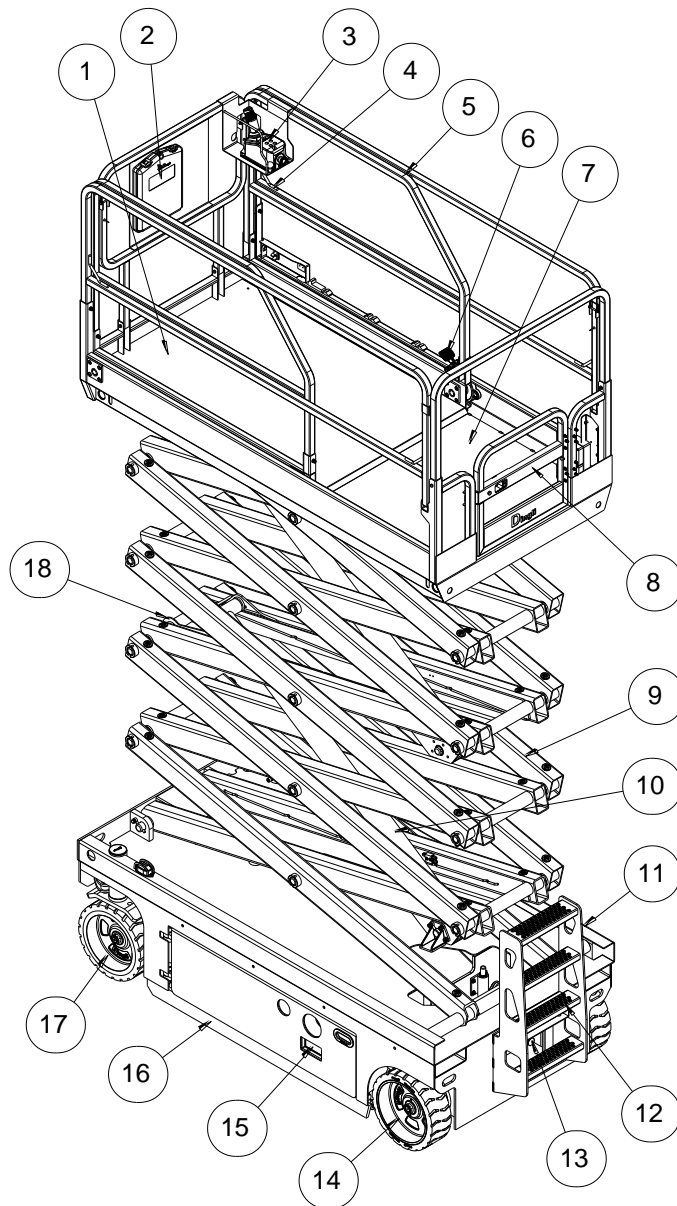

- |                                    |  |
|------------------------------------|--|
| 1 Platform extension               | 10 Lift Cylinder                                 |
| 2 Manual storage container         | 11 Ground controls (on opposite side of machine) |
| 3 Platform control                 | 12 Entry ladder                                  |
| 4 Lanyard anchorage point          | 13 Brake release pump                            |
| 5 Platform guard rails             | 14 Non-steer tire                                |
| 6 Platform extension release pedal | 15 Battery charger                               |
| 7 Main Platform                    | 16 Pothole guard                                 |
| 8 Platform entry gate              | 17 Steer tire                                    |
| 9 Scissor Arms                     | 18 Safety arm                                    |

**Decals****Decal Inspection**

Use the pictures on the next page to verify that all decals are legible and in place.

Below is a numerical list with quantities and descriptions.

<b>No.</b>	<b>Part No.</b>	<b>Description</b>	<b>Qty.</b>	<b>Remark</b>
1	9334011	Notice – Operator's manual storage	1	
2	9414137	Danger – Safety rules	1	
3	9414103	Danger – Tip-over hazard	1	
4	9314015	Instructions – Platform controller normal position	1	
5	9314013	Instructions – Refer the operator to the instructions for use	2	
6	9114025	Label – Platform console panel	1	
7	9414123	Label – Lanyard anchorage	4	
8	9414065	Label – Capacity 550 lbs	2	
9	9514013	Cosmetic – Mark	2	
10	9414127	Caution – Max. manual force: 100 lbs	2	

<b>No.</b>	<b>Part No.</b>	<b>Description</b>	<b>Qty.</b>	<b>Remark</b>
12	9514101	Cosmetic – Mark	1	
13	9514301	Cosmetic – IPAF	1	
14	9413013	Danger – Crushing hazard	5	

## Decals

15	9413011	Danger – Safety arm	4	
16	9311011	Instructions – Forklift pockets	2	
17	9311015	Instructions – Tie down point	4	
18	9311013	Instructions – Lift point	4	
19	9311421	Instructions – Wheel load: 2948 lbs	4	
<b>No.</b>	<b>Part No.</b>	<b>Description</b>	<b>Qty.</b>	<b>Remark</b>
20	9311105	Notice – Main power switch operation	1	
21	9411041	Warning – Tip-over hazard	1	
22	9411011	Danger – Explosion / burn hazard	1	
23	9411015	Danger – Tip-over hazard	1	
24	9311017	Instructions – Emergency lower	1	
25	9411029	Warning – Inspected and operation properly	1	
26	9111021	Label – Ground console panel	1	
27	9211017	Decal – Manufacturer's plate	1	

# Decals

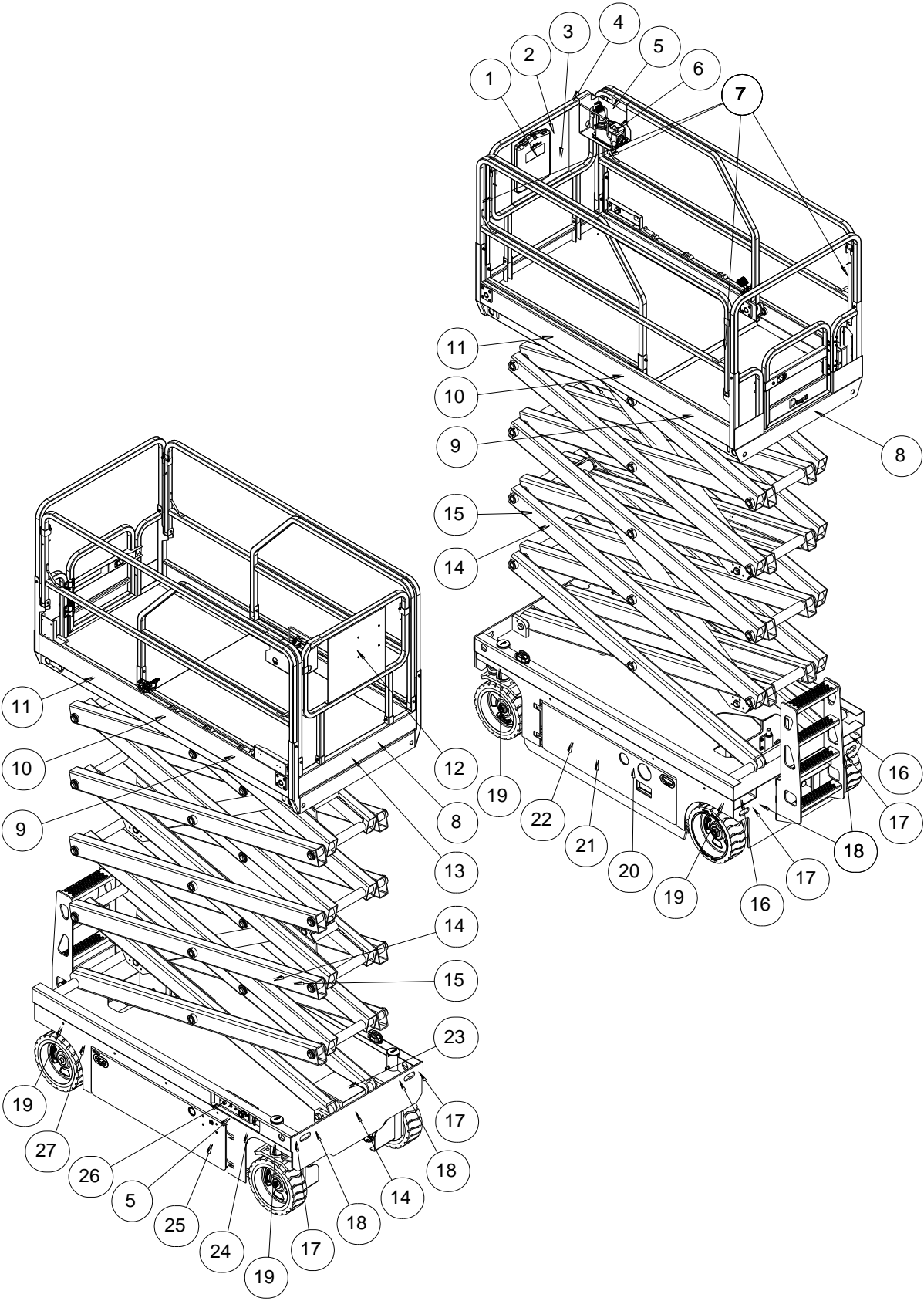





**Specifications****Model: DSL-40**

Height, working maximum	45.3 ft	13.8 m
Height, platform maximum	38.7 ft	11.8 m
Height, stowed maximum Rails up	102 in	2.59 m
Height, stowed maximum Rails folded	80.7 in	2.05 m
Width	46.8 in	1.19 m
Length, platform retracted	97.6 in	2.48 m
Length, platform extended	133.1 in	3.38 m
Platform dimensions (length x width)	89.4x44.1 in 2.27x1.12 m	
Platform extension length	35.4 in	0.9 m
Maximum load capacity	550 lbs	250 kg
Wheelbase	73.6 in	1.87 m
Turning radius (outside)	86.6 in	2.2 m
Turning radius (inside)	0 in	0 m
Ground clearance	3.9 in	10 cm
Ground clearance Pothole guards deployed	0.7 in	1.9 cm
Weight Machine weights vary with option configurations	(See Serial Label)	
Power source	4 Batteries , 12V 300 Ah	
Controls	Proportional	
AC outlet in platform	Standard	

Maximum hydraulic pressure (functions)	3000 psi 207 bar	
System voltage	24 V	
Tire size	15x5 in	Φ381x127 mm

Airborne noise emissions <70 dB  
Maximum sound level at normal operating workstations (A-weighted)

Vibration value does not exceed 2.5m/s<sup>2</sup>

Gradeability 25% (14°)

Note: Slope rating is subject to ground conditions and adequate traction.

Warning slope X-2°,Y-3°

**Drive speeds**

Stowed, maximum	2.5 mph	4.0 km/h
Platform raised, maximum	0.5 mph	0.8 km/h

**Floor loading information**

Tire load, maximum	2948 lbs	1340 kg
Tire contact pressure	167 psi	11.7 kg/cm <sup>2</sup> 1148.9 kPa
Occupied floor pressure	255 psf	1240.1 kg/m <sup>2</sup> 12.2 kPa

Note: Floor loading information is approximate and does not incorporate different option configurations. It should be used only with adequate safety factors.

Continuous improvement of our products is a Ballymore policy. Product specifications are subject to change without notice or obligation.

## Control Panel

### Ground Control Panel

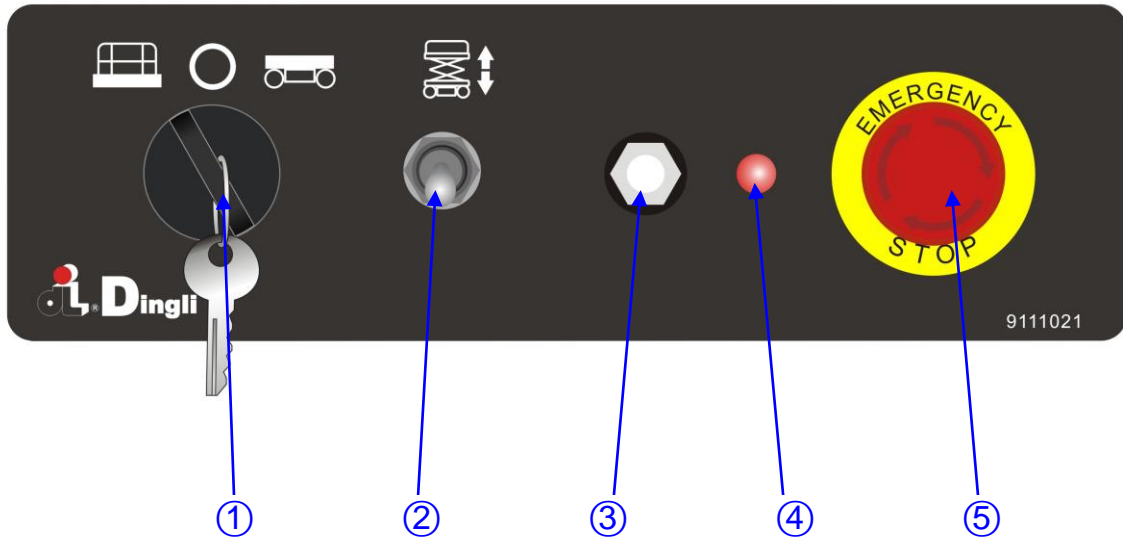

- 1 Key switch for platform / off / ground control selection

Turn the key switch to the platform position and the platform controls will operate. Turn the key switch to the off position and the machine will be off. Turn the key switch to the base position and the ground controls will operate.

- 2 Platform up / down switch

Move the switch up and the platform will raise. Move the switch down and the platform will lower.

- 3 7 amp breaker for electric circuits

- 4 Indicator light

- 5 Red Emergency Stop button

Push in the red Emergency Stop button to the off position to stop all functions. Turn the red Emergency Stop button clockwise to the on position to operate the machine.

## Control Panel

### Platform Control Panel

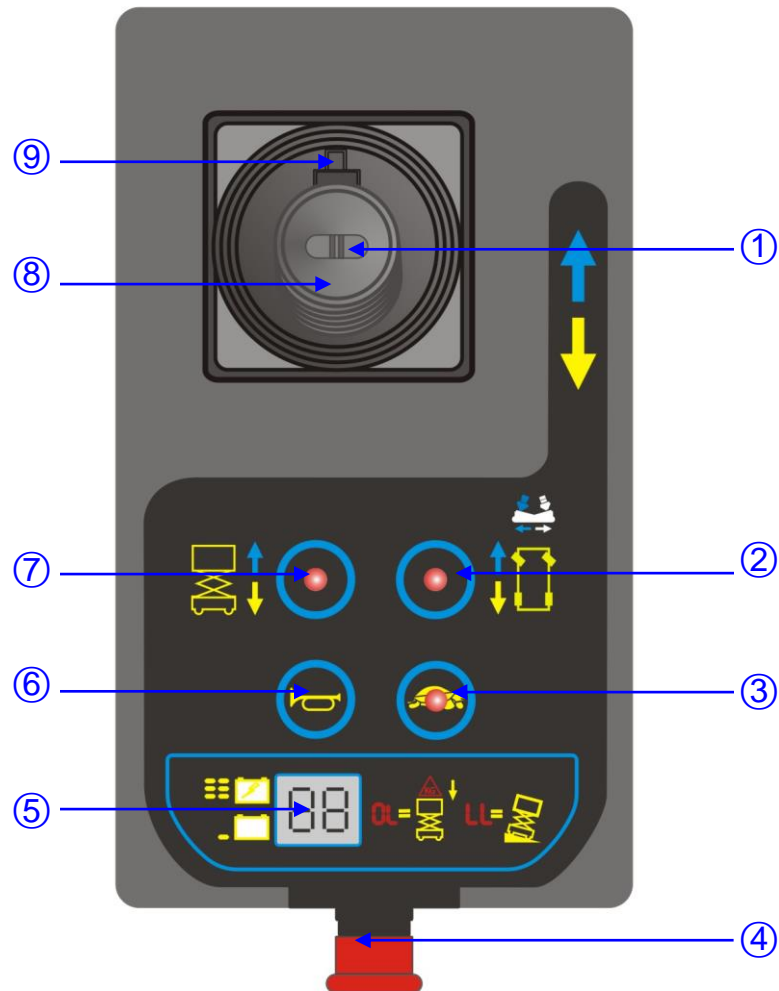

- |   |   |   |   |
|---|---|---|---|
| 1 | Thumb rocker switch for steer functions | 6 | Horn button   |
| 2 | Drive function select button            | 7 | Lift function select button                         |
| 3 | Drive speed button                      | 8 | Proportional control handle                         |
| 4 | Red Emergency Stop button               | 9 | Function enable switch for lift and drive functions |
| 5 | LED                                     |   |   |

## Control Panel

### Platform Control Panel

- 1 Thumb rocker switch for steer functions  
Press the thumb rocker switch in either direction to activate steer function.
- 2 Drive function select button  
Press this button to activate the drive function.
- 3 Drive speed button  
Press this button to activate the slow or fast drive function.
- 4 Red Emergency Stop button  
Push in the red Emergency Stop button to the off position to stop all functions. Turn the red Emergency Stop button clockwise to the on position to operate the machine.
- 5 LED  
Diagnostic readout and battery charge indicator.
- 6 Horn Button  
Push the horn button and the horn will sound. Release the horn button and the horn will stop.
- 7 Lift function select button  
Press this button to activate the lift function.
- 8 Proportional control handle
- 9 Function enable switch for lift and drive functions  
Lift function: Press and hold the function enable switch to enable the lift function on the platform control handle. Move the control handle in the direction indicated by the blue arrow and the platform will raise. Move the control handle in the direction indicated by the yellow arrow and the platform will lower. The descent alarm should sound while the platform is lowering.  
Drive function: Press and hold the function enable switch to enable the drive function on the platform control handle. Move the control handle in the direction indicated by the blue arrow on the control panel and the machine will move in the direction that the blue arrow points. Move the control handle in the direction indicated by the yellow arrow on the control panel and the machine will move in the direction that the yellow arrow points.

## Pre-operation Inspection



### Do Not Operate Unless:

✓ You learn and practice the principles of safe machine operation contained in this operator's manual.

- 1 Avoid hazardous situations.
- 2 Always perform a pre-operation inspection.**

**Know and understand the pre-operation inspection before going on to the next section.**

- 3 Inspect the workplace.
- 4 Always perform function tests prior to use.
- 5 Only use the machine as it was intended.

### Fundamentals

It is the responsibility of the operator to perform a pre-operation inspection and routine maintenance.

The pre-operation inspection is a visual inspection performed by the operator prior to each work shift. The inspection is designed to discover if anything is apparently wrong with a machine before the operator performs the function tests.

The pre-operation inspection also serves to determine if routine maintenance procedures are required. Only routine maintenance items specified in this manual may be performed by the operator.

Refer to the list on the next page and check each of the items.

If damage or any unauthorized variation from factory delivered condition is discovered, the machine must be tagged and removed from service.

Repairs to the machine may only be made by a qualified service technician, according to the manufacturer's specifications. After repairs are completed, the operator must perform a pre-operation inspection again before going on to the function tests.

Scheduled maintenance inspections shall be performed by qualified service technicians, according to the manufacturer's specifications and the requirements listed in this manual.

## Pre-operation Inspection

### Pre-operation Inspection

- Be sure that the operator's manual are complete, legible and in the storage container located in the platform.
- Be sure that all decals are legible and in place. See Decals section.
- Check for hydraulic oil leaks and proper oil level. Add oil if needed. See Maintenance section.
- Check for battery fluid leaks and proper fluid level. Add distilled water if needed. See Maintenance section.

Check the following components or areas for damage, improperly installed or missing parts and unauthorized modifications:

- Electrical components, wiring and electrical cables
- Hydraulic hoses, fittings, cylinders and manifolds
- Battery pack and connections
- Drive motors
- Wear pads
- Tires and wheels
- Ground strap
- Limit switches, alarms and horn
- Nuts, bolts and other fasteners
- Platform overload components
- Platform entry gate
- Beacon and alarms (if equipped)
- Safety arm
- Platform extension(s)
- Scissor pins and retaining fasteners
- Platform control joystick
- Brake release components
- Pothole guard

Check entire machine for:

- Cracks in welds or structural components
- Dents or damage to machine
- Be sure that all structural and other critical components are present and all associated fasteners and pins are in place and properly tightened
- Be sure side rails are installed and rail pins and bolts are fastened.
- Be sure that the chassis trays are closed and latched and the batteries are properly connected.

Note: If the platform must be raised to inspect the machine, make sure the safety arm is in place. See Operating Instructions section.

## Workplace Inspection



### Do Not Operate Unless:

You learn and practice the principles of safe machine operation contained in this operator's manual.

- 1 Avoid hazardous situations.
- 2 Always perform a pre-operation inspection.
- 3 Inspect the workplace.**

**Know and understand the workplace inspection before going on to the next section.**

- 4 Always perform function tests prior to use.
- 5 Only use the machine as it was intended.

### Fundamentals

The workplace inspection helps the operator determine if the workplace is suitable for safe machine operation. It should be performed by the operator prior to moving the machine to the workplace.

It is the operator's responsibility to read and remember the workplace hazards, then watch for and avoid them while moving, setting up and operating the machine.

### Workplace Inspection

Be aware of and avoid the following hazardous situations:

- Drop-offs or holes
- Bumps, floor obstructions or debris
- Sloped surfaces
- Unstable or slippery surfaces
- Overhead obstructions and high voltage conductors
- Hazardous locations
- Inadequate surface support to withstand all load forces imposed by the machine
- Wind and weather conditions
- The presence of unauthorized personnel
- Other possible unsafe conditions



## Function Tests



### Do Not Operate Unless:

You learn and practice the principles of safe machine operation contained in this operator's manual.

- 1 Avoid hazardous situations.
- 2 Always perform a pre-operation inspection.
- 3 Inspect the workplace.
- 4 **Always perform function tests prior to use.**

**Know and understand the function tests before going on to the next section.**

- 5 Only use the machine as it was intended.

### Fundamentals

The function tests are designed to discover any malfunctions before the machine is put into service.

The operator must follow the step-by-step instructions to test all machine functions.

A malfunctioning machine must never be used. If malfunctions are discovered, the machine must be tagged and removed from service.

Repairs to the machine may only be made by a qualified service technician, according to the manufacturer's specifications.

After repairs are completed, the operator must perform a pre-operation inspection and function tests again before putting the machine into service.

## Function Tests

- 1 Select a test area that is firm, level and free of obstruction.
- 2 Be sure the battery pack is connected.

### At the Ground Controls

- 3 Turn the red Emergency Stop button clockwise to the on position at both the ground and platform controls.
- 4 Turn the key switch to ground control.
- 5 Observe the diagnostic LED readout on the ECU window.

- ⊙ Result: The LED should look like the picture at right.

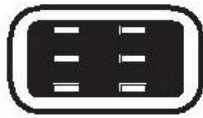

### Test Emergency Stop

- 6 Push in the ground red Emergency Stop button to the off position.
- ⊙ Result: No functions should operate.
- 7 Turn the red Emergency Stop button clockwise to the on position.

### Test Up/Down Functions

A buzzer with different sound frequency is controlled in central system. The descent alarm sounds at 60 beeps per minute. The alarm that goes off when the pothole guards have not deployed sounds at 150 beeps per minute. The alarm that goes off when the machine is not level sounds at 150 beeps per minute. An optional automotive-style horn is also available.

- 8 Turn the key switch to off or platform position.
  - 9 Move up and hold the platform up / down switch.
- ⊙ Result: No function should operate.
- 10 Turn the key switch to ground control position.
  - 11 Move up and hold the platform up / down

switch.

- ⊙ Result: The platform should rise.
- 12 Move down and hold the platform up / down switch.
- ⊙ Result: The platform should lower to end. The descent alarm should sound while the platform is lowering.

### Test the Emergency Lowering

- 13 Activate the up function and raise the platform approximately 2 ft / 60 cm.
  - 14 Pull the emergency lowering knob.
- ⊙ Result: The platform should lower. The descent alarm will not sound.
- 15 Turn the key switch to platform control.

## At the Platform Controls

### Test Emergency Stop

- 16 Push in the platform red Emergency Stop button to the off position.
- ⊙ Result: No functions should operate.
- 17 Turn the red Emergency Stop button clockwise to the on position.
- ⊙ Result: The LED indicator light should come on.

### Test the Horn

- 18 Push the horn button.
- ⊙ Result: The horn should sound.

### Test Function Enable and Up/Down Functions

- 19 Do not hold the function enable switch on the control handle.
- 20 Slowly move the control handle in the direction indicated by the blue arrow, then

## Function Tests

in the direction indicated by the yellow arrow.

- ⊙ Result: No functions should operate.
- 21 Press the lift function select button.
- 22 Press and hold the function enable switch on the control handle.
- 23 Slowly move the control handle in the direction indicated by the blue arrow.
- ⊙ Result: The platform should raise. The pothole guards should deploy.
- 24 Release the control handle.
- ⊙ Result: The platform should stop raising.
- 25 Press and hold the function enable switch. Slowly move the control handle in the direction indicated by the yellow arrow.
- ⊙ Result: The platform should lower. The descent alarm should sound while the platform is lowering.

### Test the Steering

Note: When performing the steer and drive function tests, stand in the platform facing the steer end of the machine.

- 26 Press the drive function select switch.
- 27 Press and hold the function enable switch on the control handle.
- 28 Depress the thumb rocker switch on top of the control handle in the direction identified by the blue left arrow on the control panel.
- ⊙ Result: The steer wheels should turn in the direction that the blue left arrow points on the control panel.
- 29 Depress the thumb rocker switch in the direction identified by the white right arrow on the control panel.
- ⊙ Result: The steer wheels should turn in the direction that the white right arrow points on the control panel.

### Test Drive and Braking

- 30 Press and hold the function enable switch on the control handle.
- 31 Slowly move the control handle in the direction indicated by the blue up arrow on the control panel until the machine begins to move, then return the handle to the center position.
- ⊙ Result: The machine should move in the direction that the blue up arrow points on the control panel, then come to an abrupt stop.
- 32 Press and hold the function enable switch on the control handle.
- 33 Slowly move the control handle in the direction indicated by the yellow down arrow on the control panel until the machine begins to move, then return the handle to the center position.
- ⊙ Result: The machine should move in the direction that the yellow down arrow points on the control panel, then come to an abrupt stop.

Note: The brakes must be able to hold the machine on any slope it is able to climb.

### Test Limited Drive Speed

- 34 Press and hold the lift function enable switch. Raise the platform approximately 6.6ft / 2m from the ground.
- ⊙ Result: The pothole guards should deploy.
- 35 Press and hold the function enable switch on the control handle.
- 36 Slowly move the control handle to the full drive position.
- ⊙ Result: The maximum achievable drive speed with the platform raised should not exceed 0.72 ft per second / 22 cm/s.
- ⊗ Result: If the drive speed with the platform

## Function Tests

raised exceeds 0.72 ft per second / 22 cm/s, immediately tag and remove the machine from service.

### Test the Tilt Sensor Operation

Note: Perform this test from the ground with the platform controller. Do not stand in the platform.

37 Fully lower the platform.

38 Place a 2.0×7.9 in / 5×20 cm or similar piece of wood under both wheels on one side and drive the machine up onto them.

39 Raise the platform at least 6.6 ft / 2 m.

⊙ Result: The platform should stop and the tilt alarm will sound at 150 beeps per minute.

40 Lower the platform and drive the machine off the block.

### Test the Pothole Guards

Note: The pothole guards should automatically deploy when the platform is raised. The pothole guards activate another limit switch which allows the machine to continue to function. If the pothole guards do not deploy, an alarm sounds and the machine will not drive.

41 Raise the platform.

⊙ Result: When the platform is raised 6.6 ft / 2 m from the ground, the pothole guards should deploy.

42 Press on the pothole guards on one side, and then the other.

⊙ Result: The pothole guards should not move.

43 Lower the platform.

⊙ Result: The pothole guards should return to the stowed position.

44 Place a 2.0×7.9 in / 5×20 cm or similar piece of wood under a pothole guard. Raise the platform.

⊙ Result: Before the platform is raised 6.6 ft / 2 m from the ground, an alarm should sound and the drive function should not Work.

45 Lower the platform and remove the 2.0×7.9 in / 5×20 cm wood block.

## Operating Instructions



### Do Not Operate Unless:

- You learn and practice the principles of safe machine operation contained in this operator's manual.
  - 1 Avoid hazardous situations.
  - 2 Always perform a pre-operation inspection.
  - 3 Inspect the workplace.
  - 4 Always perform function tests prior to use.
  - 5 **Only use the machine as it was intended.**

### Fundamentals

This machine is a self-propelled hydraulic lift equipped with a work platform on the scissor mechanism. Vibrations emitted by these machines are not hazardous to an operator in the work platform. The machine can be used to position personnel with their tools and supplies at position above ground level and can be used to reach work areas located above and over machinery or equipment.

The Operating Instructions section provides instructions for each aspect of machine operation.

It is the operator's responsibility to follow all the safety rules and instructions in the operator's manual.

Using the machine for anything other than lifting personnel, along with their tools and materials, to an aerial work site is unsafe and dangerous.

Only trained and authorized personnel should be permitted to operate a machine. If more than one operator is expected to use a machine at different times in the same work shift, they must all be qualified operators and are all expected to follow all safety rules and instructions in the operator's manual. That means every new operator should perform a pre-operation inspection, function tests, and a workplace inspection before using the machine.

## Operating Instructions

### Emergency Stop

Push in the red Emergency Stop button to the off position at the ground controls or the platform controls to stop all machine functions.

Repair any function that operates when either red Emergency Stop button is pushed in.

### Emergency Lowering

- 1 Pull the emergency lowering knob.

### Operation from Ground

- 1 Turn the key switch to ground control.
- 2 Turn the red Emergency Stop button clockwise to the on position at both the ground and platform controls.
- 3 Be sure the battery pack is connected before operating the machine.

#### To Position Platform

- 1 Move the platform up/down switch according to the markings on the control panel.

Drive and steer functions are not available from the ground controls.

### Operation from Platform

- 1 Turn the key switch to platform control.
- 2 Turn the red Emergency Stop button clockwise to the on position at both the ground and platform controls.
- 3 Be sure the battery pack is connected before operating the machine.

#### To Position Platform

- 1 Press the lift function select button.
- 2 Press and hold the lift function enable switch on the control handle.

- 3 Move the control handle according to the markings on the control panel.

#### To Steer

- 1 Press the drive function select button.
- 2 Press and hold the function enable switch on the control handle.
- 3 Turn the steer wheels with the thumb rocker switch located on the top of the control handle.

#### To Drive

- 1 Press the drive function select button.
- 2 Press and hold the function enable switch on the control handle.
- 3 Increase speed: Slowly move the control handle off center.

Decrease speed: Slowly move the control handle toward center.

Stop: Return the control handle to center or release the function enable switch.

Use the color-coded direction arrows on the platform controls to identify the direction the machine will travel.

Machine travel speed is restricted when the platform is raised.

Battery condition will affect machine performance. Machine drive speed and function speed will drop when the battery level indicator is flashing.

#### To reduce drive speed

The drive controls can operate in two different drive speed modes. When the drive speed button light is on, slow drive speed mode is active. When the button light is off, fast drive speed mode is active.

Press the drive speed button to select the desired drive speed.

## Operating Instructions

### ▲ Driving on a slope

Determine the slope and side slope ratings for the machine and determine the slope grade.

Maximum slope rating, stowed position level 25% (14°), Maximum side slope rating, stowed position level 5°.

Note: Slope rating is subject to ground conditions and adequate traction.

Press the drive speed button to the fast drive speed mode.

### To determine the slope grade

Measure the slope with a digital inclinometer OR use the following procedure.

You will need:

Carpenter's level

Straight piece of wood, at least 3.3 ft / 1 m long

Tape measure

Lay the piece of wood on the slope.

At the downhill end, lay the level on the top edge of the piece of wood and lift the end until the piece of wood is level.

While holding the piece of wood level, measure the distance from the bottom of the piece of wood to the ground.

Divide the tape measure distance (rise) by the length of the piece of wood (run) and multiply by 100.

Example:

Run = 12 ft / 3.6 m

Rise = 12 in / 0.3 m

$12 \text{ in} \div 144 \text{ in} = 0.083 \times 100 = 8.3\%$

$0.3 \text{ m} \div 3.6 \text{ m} = 0.083 \times 100 = 8.3\%$



If the slope exceeds the maximum slope or side slope rating, the machine must be winched or transported up or down the slope. See Transport and Lifting section.

### Operation from Ground with Controller

Maintain safe distances between operator, machine and fixed objects.

Be aware of the direction the machine will travel when using the controller.

Battery Level Indicator

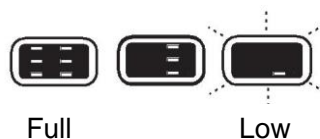

Use the LED diagnostic readout to determine the battery level.

### How to use the Safety Arm

- 1 Raise the platform approximately 8.2 ft / 2.5 m from the ground.
- 2 Lift the safety arm, move it to the center of the scissor arm and rotate up to a vertical position.
- 3 Lower the platform until the safety arm rests securely on the link. Keep clear of the safety arm when lowering the platform.

**▲ DANGER** Don't engage the safety arm unless unload the platform.

### How to Fold Down the Guardrails

The platform railing system consists of three fold down rail section for the extension deck and three sections for the main deck. All sections are held in place by four wire lock pins.

## Operating Instructions

- 1 Fully lower the platform and retract the platform extension.
- 2 Remove the platform controls.
- 3 From inside the platform, remove the two front extension deck wire lock pins.
- 4 Fold down the front rail assembly. Keep hands clear of pinch points.
- 5 Replace the two removed pins back into each side rail bracket.
- 6 Fold down the extension platform right rail assembly. Keep hands clear of pinch points.
- 7 Fold down the extension platform left rail assembly. Keep hands clear of pinch points.
- 8 Carefully open the gate and move to the rear step or the ground.
- 9 From the rear step or from the ground, remove the right rear main deck wire lock pins.
- 10 Fold down the right rail assembly. Keep hands clear of pinch points.
- 11 Replace the removed pin back into rear rail bracket.
- 12 Remove the left rear main deck wire lock pins.
- 13 Fold down the left rail assembly. Keep hands clear of pinch points.
- 14 Replace the removed pin back into rear rail bracket.
- 15 Fold down the rear rail assemble. Keep hands free of pinch points.

### To Extend and Retract Platform

- 1 Press the platform lock pin pedal on the extension deck by foot.
- 2 Push the platform extension guardrail to extend the platform to the desired position.  
  
Do not stand on the platform extension while trying to extend it.

### How to Raise the Guardrails

Follow the fold down instructions but in reverse order.



## Operating Instructions

### Error indicator readout



If the LED diagnostic readout displays an error code, such as LL, push in and turn the red Emergency Stop button to reset the system.

#### List of Fault Codes

Display	Description	Lift Reaction
01	System initialization Fault	Disables All Motion
02	System communication Fault	Disables All Motion
03	Invalid option setting Fault	Disables All Motion
12	Chassis Up/Down Switch ON at Power-up Fault	Disable Chassis Control
18	Pothole Guard Fault	Disable Lifting and Driving
31	Pressure Sensor Fault	Disables All Motion
32	Angle Sensor Fault	Disables All Motion
34	Reserved	
42	Platform Left Turn Switch ON at power-up Message	Diagnostic Message Only
43	Platform Right Turn Switch ON at power-up Message	Diagnostic Message Only
46	Platform Joystick Enable Switch ON at power-up Fault	Disable Platform Control
47	Platform Joystick not in neutral at power-up Message	Diagnostic Message Only
52	Drive Forward Coil Fault	Disable Lifting and Driving
53	Drive Reverse Coil Fault	Disable Lifting and Driving
54	Lift Up Coil Fault	Disable Lifting and Driving
55	Lift Down Coil Fault	Disable Lifting and Driving
56	Right Turn Coil Fault	Disable Lifting and Driving
57	Left Turn Coil Fault	Disable Lifting and Driving
58	General Brake Coil Fault	Disable Lifting and Driving
59	Parallel Coil Fault	Disable Lifting and Driving
61	Motor Controller Current Sensor Fault	Controller Dependent
62	Motor Controller Hardware Failsafe Fault	Controller Dependent

**Operating Instructions**

<b>Display</b>	<b>Description</b>	<b>Lift Reaction</b>
63	Motor Controller Motor Output Fault	Controller Dependent
64	Motor Controller SRO Fault	Controller Dependent
65	Motor Controller Throttle Fault	Controller Dependent
66	Motor Controller Emergency Reverse Fault	Controller Dependent
67	Motor Controller HPD Fault	Controller Dependent
68	Low Voltage Fault	Disable All Motion
69	High Neutral Current Fault	Disable All Motion
70	Steering Input Out of Range	Disable All Motion
71	Motor Controller Main Contactor Fault	Disable Lifting and Driving
72	Motor Controller Over Voltage Fault	Controller Dependent
73	Motor Controller Thermal Cutback Fault	Controller Dependent
74	Motor Controller Motor Fault	Controller Dependent
75	Motor Controller Pump Motor Fault	Controller Dependent
76	Motor Controller Left Drive Motor Fault	Controller Dependent
77	Motor Controller Right Drive Motor Fault	Controller Dependent
78	Pump Motor Short Fault	Disable Lifting and Driving
79	Left Drive Motor Short Fault	Disable Lifting and Driving
80	Over 80% Load Warning	Warning Only
81	Right Drive Motor Short Fault	Disable Lifting and Driving
82	Right Brake Coil Fault	Disable Lifting and Driving
83	Left Brake Coil Fault	Disable Lifting and Driving
90	Over 90% Load Warning	Warning Only
99	Over 99% Load Warning	Warning Only

## Operating Instructions

### Troubleshooting Guide

Display	Description
01	System Initialization Fault: ECU may be malfunctioning, replace it.
02	System Communication Fault: Check communications cable connections and other wiring. If that does not resolve the problem, try replacing the PCU or ECU.
03	Invalid Option setting Fault: Set appropriate option for this lift.
12	Chassis Toggle Switch ON at power-up Fault: Check the wires to the Toggle Switch or look for a stuck Toggle Switch.
18	Pothole Guard Fault: Check that the pothole guards are extended, check the pothole limit switches. Check wires to the switches, check the down limit switch and connections.
31	Pressure Sensor Fault: Check the wiring to the sensor and then the sensor itself. Also check to make sure that the correct option is properly selected (or not) for load sensing.
32	Angle Sensor Fault: Check the wiring to the sensor and then the sensor itself. Also check to make sure that the correct option is properly selected (or not) for load sensing.
42	Platform Left Turn Switch ON at power-up Message: Ensure that nothing is holding the Joystick Toggle Switches down. If OK, consider replacing the Joystick or PCU.
43	Platform Right Turn Switch ON at power-up Message: Ensure that nothing is holding the Joystick Toggle Switches down. If OK, consider replacing the Joystick or PCU.
46	Platform Joystick Enable Switch ON at power-up Fault: Ensure that nothing is holding the Enable switch closed. Also check the neutral zone parameters. If OK, consider replacing the Joystick or PCU.
47	Platform Joystick not in neutral at power-up Message: Make sure that the Joystick is in the neutral (upright) position. Check the neutral zone parameter setting in Ballymore/ Dingli Scissor Programmer. If it's OK, consider replacing the Joystick or the PCU.
52	Drive Forward Coil Fault: Check the connections to the Coil's terminals and make sure they are tight. If so, check the coil itself to see if it is open or shorted.
53	Drive Reverse Coil Fault: Check the connections to the Coil's terminals and make sure they are tight. If so, check the coil itself to see if it is open or shorted.
54	Lift Up Coil Fault: Check the connections to the Coil's terminals and make sure they are tight. If so, check the coil itself to see if it is open or shorted.
55	Lift Down Coil Fault: Check the connections to the Coil's terminals and make sure they are tight. If so, check the coil itself to see if it is open or shorted.
56	Right Turn Coil Fault: Check the connections to the Coil's terminals and make sure they are tight. If so, check the coil itself to see if it is open or shorted.
57	Left Turn Coil Fault: Check the connections to the Coil's terminals and make sure they are tight. If so, check the coil itself to see if it is open or shorted.
58	General Brake Coil Fault: Check the connections to the Coil's terminals and make sure they are tight. If so, check the coil itself to see if it is open or shorted.

**Operating Instructions**

<b>Display</b>	<b>Description</b>
59	Parallel Coil Fault: Check the connections to the Coil's terminals and make sure they are tight. If so, check the coil itself to see if it is open or shorted.
61	Motor Controller Current Sensor Fault: Drive or Lift Motor may be overheating. Let the lift cool down. If that does not help, cycle power to reset the Motor controller. If the problem persists, check the wiring and if OK, try replacing the Motor Controller.
62	Motor Controller Hardware Failsafe Fault: Cycle power. If that does not resolve the issue check for noise sources. If still needed, try replacing the Motor Controller.
63	Motor Controller Motor Output fault: Check wiring first then cycle power. If needed replace controller.
64	Motor Controller SRO Fault: Look at motor enable delay with the Ballymore/ Dingli Scissor Programmer, it may be too short. Make sure other Motor Controller parameters are properly selected.
65	Motor Controller Throttle Fault: Check wiring. Make sure the correct throttle type is selected in the Motor Controller.
67	Motor Controller HPD Fault: Look at motor enable delay with the Ballymore/ Dingli Scissor Programmer, it may be too short. Make sure other Motor Controller parameters are properly selected.
68	Low Voltage Fault: Check battery voltage and charge batteries if necessary. Check the battery connections and tighten or clean. Check the voltage to the ECU and PCU.
69	High Neutral Current: The MC is sensing current in the motors when there should not be. This could occur anytime the MC thinks the brakes are on and the motors are still turning. This message sometimes comes just before other faults but should be ignored in those cases.
70	Steering Input Out of Range: There is an inappropriate voltage at the steering input of the motor controller. The controller may need to be "trained" for the three steering voltages (on Differential Steered machines). Or the steering voltage from the ECU was at some point outside of the range that was recorded during the "training" session. Retrain the controller and/or check for fluctuating voltages due to loose wires, etc.
71	Motor Controller Main Contactor Fault: Check the connections to the main contactor. Replace the contactor if necessary. Replace the Motor Controller if necessary.
72	Motor Controller Over Voltage Fault: Check battery voltage and make sure the battery charger is not on. The cycle power to the lift. If that does not resolve the issue, try replacing the Motor Controller.
73	Motor Controller Thermal Cutback Fault: Drive or Lift Motor may be overheating. Let the lift cool down. If that does not help cycle power to reset the Motor controller. If that doesn't resolve the issue, replace the Motor Controller.
74	Motor Controller Motor Fault: Check connections to the motors. Cycle power to the lift and if that does not resolve the issue, replace the Motor Controller.
75	Motor Controller Pump Motor Fault: Check connections to the Pump Motor. Cycle power to the lift and if that does not resolve the issue, replace the Motor Controller.

## Operating Instructions

Display	Description
76	Motor Controller Left Drive Motor Fault: Check connections to the motors. Cycle power to the lift and if that does not resolve the issue, replace the Motor Controller.
77	Motor Controller Right Drive Motor Fault: Check connections to the motors. Cycle power to the lift and if that does not resolve the issue, replace the Motor Controller.
78	Pump Motor Short Fault: Check connections to the pump motor. Cycle power to the lift and if that does not resolve the issue, replace the Motor Controller.
79	Left Drive Motor Short Fault: Check the Motor connections and make sure they are tight. Check the Motor for a short.
80	Over 80% Load Warning: Platform is getting close to its limit of weight. Consider not adding more load.
81	Right Drive Motor Short Fault: Check the Motor connections and make sure they are tight. Check the Motor for a short.
82	Right Brake Coil Fault: Check the connections to the Coil's terminals and make sure they are tight. If so, check the coil itself to see if it is open or shorted.
83	Left Brake Coil Fault: Check the connections to the Coil's terminals and make sure they are tight. If so, check the coil itself to see if it is open or shorted.
90	Over 90% Load Warning: Platform is getting close to its limit of weight. Consider not adding more load.
99	Over 99% Load Warning: Platform has reached its limit of weight. Do not add more load.

For more information, please consult the appropriate Ballymore Service Dept.

## Operating Instructions



### Battery and Charger Instructions

#### Observe and Obey:

- Do not use an external charger or booster battery.
- Charge the battery in a well-ventilated area.
- Use proper AC input voltage for charging as indicated on the charger.
- Use only a Ballymore authorized battery and charger.

#### To Charge Battery

- 1 Be sure the batteries are connected before charging the batteries.
- 2 Open the battery compartment. The compartment should remain open for the entire charging cycle.

#### Maintenance - free batteries

- 3 Connect the battery charger to a grounded AC circuit.
- 4 The charger will indicate when the battery is fully charged.

#### Standard Batteries

- 5 Remove the battery vent caps and check the battery acid level. If necessary, add only enough distilled water to cover the plates. Do not overfill prior to the charge cycle.

- 6 Replace the battery vent caps.
- 7 Connect the battery charger to a grounded AC circuit.
- 8 The charger will indicate when the battery is fully charged.
- 9 Check the battery acid level when the charging cycle is complete. Replenish with distilled water to the bottom of the fill tube. Do not overfill.

#### Dry Battery Filling and Charging Instructions

- 1 Remove the battery vent caps and permanently remove the plastic seal from the battery vent openings.
- 2 Fill each cell with battery acid (electrolyte) until the level is sufficient to cover the plates.

Do not fill to maximum level until the battery charge cycle is complete. Overfilling can cause the battery acid to overflow during charging. Neutralize battery acid spills with baking soda and water.

- 3 Install the battery vent caps.
- 4 Charge the battery.
- 5 Check the battery acid level when the charging cycle is complete. Replenish with distilled water to the bottom of the fill tube. Do not overfill.

## Transport and Lifting Instructions



### Observe and Obey:

- Common sense and planning must be applied to control the movement of the machine when lifting it with a crane or forklift.
- Only qualified aerial lift operators should move the machine on or off the truck.
- The transport vehicle must be parked on a level surface.
- The transport vehicle must be secured to prevent rolling while the machine is being loaded.
- Be sure the vehicle capacity, loading surfaces and chains or straps are sufficient to withstand the machine weight. See the serial label for the machine weight.
- The machine must be on a level surface or secured before releasing the brakes.
- Do not allow the rails to fall when the snap pins are removed. Maintain a firm grasp on the rails when the rails are lowered.
- Do not drive the machine on a slope that exceeds the slope or side slope rating. See Driving on a Slope in the Operating Instructions section.
- If the slope of the transport vehicle bed exceeds the maximum slope rating, the machine must be loaded and unloaded using a winch as described.

### Brake Release Operation

#### For the DC Motor Drive Model

- 1 Chock the wheels to prevent the machine from rolling.
- 2 Turn the red Emergency Stop button clockwise to the on position at both the ground and platform controls.
- 3 Press and hold lift switch to “down” position in ground control, meanwhile turn on the key switch to the "Ground" position. The brake will be released after Alarm alerts.
- 4 If you want to close the brake release, just turn off the key switch in “ground” position.

## Transport and Lifting Instructions

Towing the Hydraulic Drive Model is not recommended. If the machine must be towed, do not exceed 2.2 mph / 3.5 km/h.

Towing the DC Motor Drive Model is not recommended. If the machine must be towed, do not exceed 2.5 mph / 4.0 km/h.

Turn the key switch to the off position and remove the key before transporting.

Inspect the entire machine for loose or unsecured items.

Use the tie-down points on the chassis for anchoring down to the transport surface.

Use a minimum of four chains or straps.

Use chains or straps of ample load capacity.

If the railings have been folded down, secure them with straps before transporting.

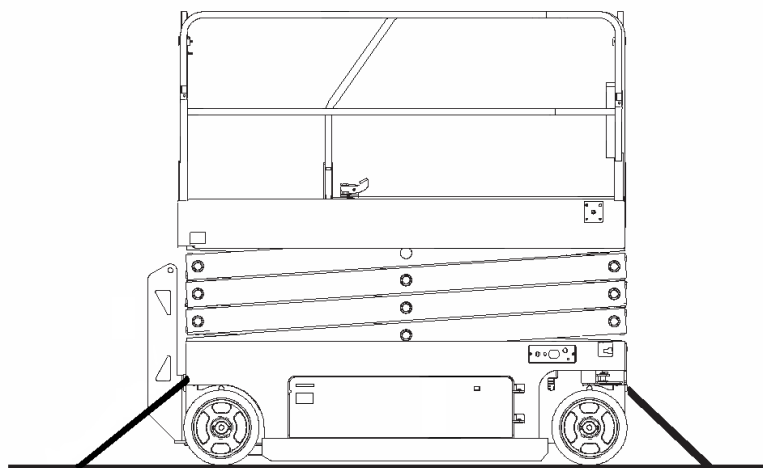
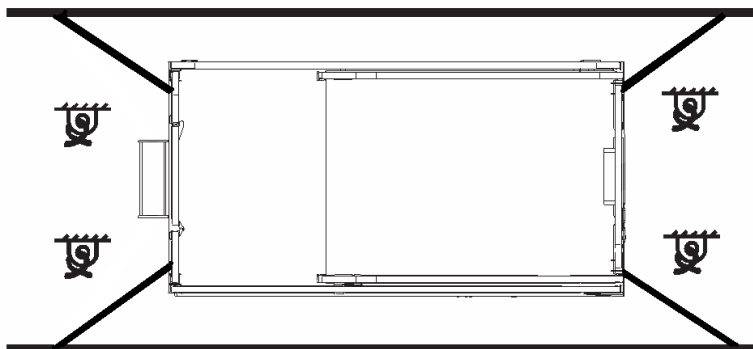

### Securing to Truck or Trailer for Transit

Always chock the machine wheels in preparation for transport.

Retract and secure the extension deck(s).



**Observe and Obey:**



## Transport and Lifting Instructions

- ✓ Only qualified riggers should rig and lift the machine.
- ✓ Only qualified forklift operators should lift the machine with a forklift.
- ✓ Be sure the crane capacity, loading surfaces and straps or lines are sufficient to withstand the machine weight. See the serial plate for the machine weight.

### Lifting the Machine with a Forklift

Be sure the extension deck, controls and component trays are secure. Remove all loose items on the machine.

Fully lower the platform. The platform must remain lowered during all loading and transport procedures.

Use the forklift pockets located on both sides of the ladder.

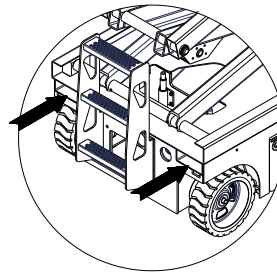

Position the forklift forks in position with the forklift pockets.

Drive forward to the full extent of the forks.

Raise the machine 6 in / 15 cm and then tilt the forks back slightly to keep the machine secure.

Be sure the machine is level when lowering the forks.

#### **NOTICE**

Lifting the machine from the side can result in component damage.

# Transport and Lifting Instructions

## Lifting Instructions

Fully lower the platform. Be sure the extension decks, controls and covers are secure. Remove all loose items on the machine.

Determine the center of gravity of your machine using the table and the picture on this page.

Attach the rigging only to the designated lifting points on the machine. There are two lifting points on each end of the machine.

Adjust the rigging to prevent damage to the machine and to keep the machine level.

## Center of Gravity

Model	X Axis	Y Axis
DSL-40	83 cm	72.1cm

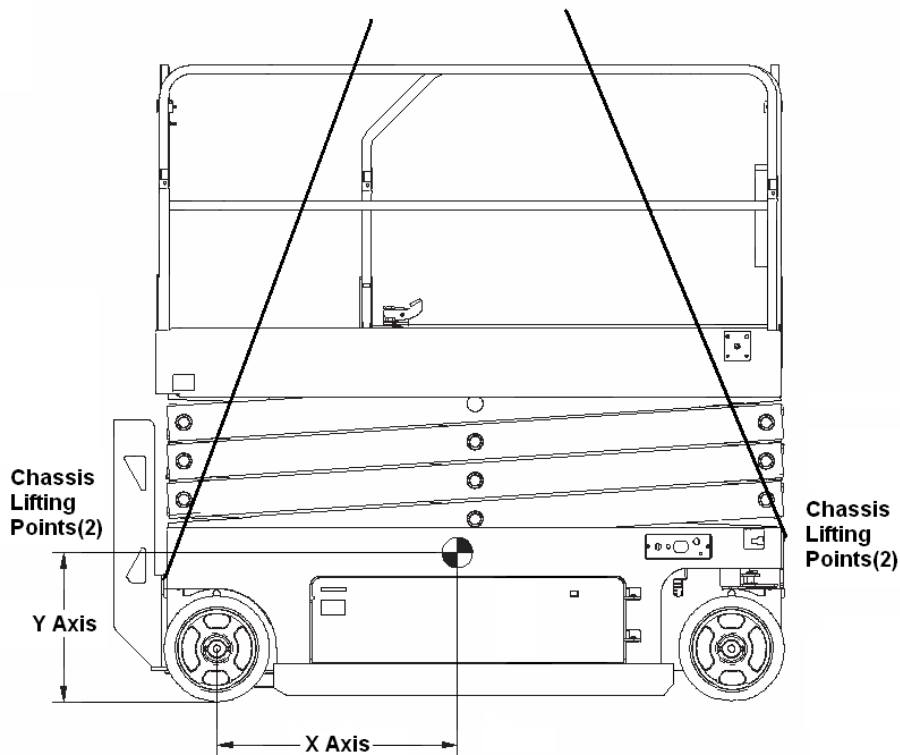

## Maintenance



### Observe and Obey:

- ✓ Only routine maintenance items specified in this manual shall be performed by the operator.
- ✓ Scheduled maintenance inspections shall be completed by qualified service technicians, according to the manufacturer's specifications and the requirements specified in this manual.

### Maintenance Symbols Legend

**NOTICE** The following symbols have been used in this manual to help communicate the intent of the instructions. When one or more of the symbols appear at the beginning of a maintenance procedure, it conveys the meaning below.



Indicates that tools will be required to perform this procedure.



Indicates that new parts will be required to perform this procedure.



Indicates that dealer service will be required to perform this procedure.

### Pre-delivery Preparation Report

The pre-delivery preparation report contains checklists for each type of scheduled inspection.

Make copies of the Pre-delivery Preparation report to use for each inspection. Store completed forms as required.

### Maintenance Schedule

There are five types of maintenance inspections that must be performed according to a schedule— daily, quarterly, semi-annually, annually, and two year. The Scheduled Maintenance Procedures Section and the Maintenance Inspection Report have been divided into five subsections—A, B, C, D, and E. Use the following chart to determine which group(s) of procedures are required to perform a scheduled inspection.

Inspection	Checklist
Daily or every 8 hours	A
Quarterly or every 250 hours	A+B
Semi-annually or every 500 hours	A+B+C
Annually or every 1000 hours	A+B+C+D
Two year or every 2000 hours	A+B+C+D+E

### Maintenance Inspection Report

The maintenance inspection report contains checklists for each type of scheduled inspection.

Make copies of the Maintenance Inspection Report to use for each inspection. Maintain completed forms for a minimum of 4 years or in compliance with your employer, jobsite and governmental regulations and requirements.

## Maintenance

### Pre-delivery Preparation Report

#### Fundamentals

It is the responsibility of the dealer to perform the Pre-delivery Preparation.

The Pre-delivery Preparation is performed prior to each delivery. The inspection is designed to discover if anything is apparently wrong with a machine before it is put into service.

A damaged or modified machine must never be used. If damage or any variation from factory delivered condition is discovered, the machine must be tagged and removed from service.

Repairs to the machine may only be made by a qualified service technician, according to the manufacturer's specifications.

Scheduled maintenance inspections shall be performed by qualified service technicians, according to the manufacturer's specifications and the requirements listed in this manual.

#### Instructions

Use the operator's manual on your machine.

The Pre-delivery Preparation consists of completing the Pre-operation Inspection, the Maintenance items and the Function Tests.

Use this form to record the results. Place a check in the appropriate box after each part is completed. Follow the instructions in the operator's manual.

If any inspection receives an N, remove the machine from service, repair and re-inspect it. After repair, place a check in the R box.

#### Legend

Y = yes, completed

N = no, unable to complete

R = repaired

#### Comments

Pre-Delivery Preparation	Y	N	R
Pre-operation inspection completed			
Maintenance items completed			
Function tests completed			

Model

Serial number

Date

Machine owner

Inspected by (print)

Inspector signature

Inspector title

Inspector company

# Maintenance

## Maintenance Inspection Report

<b>Model</b>
<b>Serial number</b>
<b>Date</b>
<b>Hour meter</b>
<b>Machine owner</b>
<b>Inspected by (print)</b>
<b>Inspector signature</b>
<b>Inspector title</b>
<b>Inspector company</b>
<b>Instructions</b>
<ul style="list-style-type: none"> <li>• Make copies of this report to use for each inspection.</li> <li>• Select the appropriate checklist(s) for the type of inspection to be performed.</li> </ul>
<input type="checkbox"/> Daily or 8 hours Inspection: <span style="float: right;">A</span>
<input type="checkbox"/> Quarterly or 250 hours Inspection: <span style="float: right;">A+B</span>
<input type="checkbox"/> Semi-annually or 500 hours Inspection: <span style="float: right;">A+B+C</span>
<input type="checkbox"/> Annually or 1000 hours Inspection: <span style="float: right;">A+B+C+D</span>
<input type="checkbox"/> Two year or 2000 hours Inspection: <span style="float: right;">A+B+C+D+E</span>
<ul style="list-style-type: none"> <li>• Place a check in the appropriate box after each inspection procedure is completed.</li> <li>• Use the step-by-step procedures in this section to learn how to perform these inspections.</li> <li>• If any inspection receives an "N", tag and remove the machine from service, repair and re-inspect it. After repair, place a check in the "R" box.</li> </ul>
<b>Legend</b>
Y = yes, acceptable
N = no, remove from service
R = repaired

<b>Checklist A</b>	Y	N	R
A-1 Inspect the manuals and decals			
A-2 Pre-operation inspection			
A-3 Check the Batteries			
A-4 Check the Hydraulic Oil Level			
A-5 Function tests			
<b>Perform after 40 hours:</b>			
A-6 30 day service			
<b>Perform every 100 hours:</b>			
A-7 Grease steer yokes			
<b>Checklist B</b>	Y	N	R
B-1 Batteries			
B-2 Electrical wiring			
B-3 Tires and wheels			
B-4 Emergency stop			
B-5 Key switch			
B-6 Horn (if equipped)			
B-7 Drive brakes			
B-8 Drive speed - stowed			
B-9 Drive speed - raised			
B-10 Drive speed - slow			
B-11 Hydraulic oil analysis			
B-12 Tank venting system			
B-13 Latch components			
B-14 Test the down and pothole limit switches			
B-15 Test the up limit switches			
<b>Checklist C</b>	Y	N	R
C-1 Platform overload (if equipped)			
C-2 Breather cap - models with optional oil			
<b>Checklist D</b>	Y	N	R
D-1 Scissor arm wear pads			
D-2 Hydraulic filter			
<b>Checklist E</b>	Y	N	R
E-1 Hydraulic oil			

## Checklist A Procedures

### A-1

#### Inspect the Manuals and Decals

Maintaining the operator's manual in good condition is essential to safe machine operation. Manuals are included with each machine and should be stored in the container provided in the platform. An illegible or missing manual will not provide safety and operational information necessary for a safe operating condition.

In addition, maintaining all of the safety and instructional decals in good condition is mandatory for safe machine operation. Decals alert operators and personnel to the many possible hazards associated with using this machine. They also provide users with operation and maintenance information. An illegible decal will fail to alert personnel of a procedure or hazard and could result in unsafe operating conditions.

- 1 Check to make sure that the operator manual is present and complete in the storage container on the platform.
  - 2 Examine the pages of manual to be sure that they are legible and in good condition.
- Result: The operator manual is appropriate for the machine and the manual are legible and in good condition.
- Result: The operator's manual is not appropriate for the machine or the manual is not in good condition or is illegible. Remove the machine from service until the manual is replaced.
- 3 Open the operator's manual to the decals inspection section. Carefully and thoroughly inspect all decals on the machine for legibility and damage.

- Result: The machine is equipped with all required decals, and all decals are legible and in good condition.
- Result: The machine is not equipped with all required decals, or one or more decals are illegible or in poor condition. Remove the machine from service until the decals are replaced.
- 4 Always return the manual to the storage container after use.

Note: Contact your authorized BALLYMORE distributor or BALLYMORE Inc. if replacement manuals or decals are needed.

## Maintenance

### A-2

#### Perform Pre-operation Inspection

Completing a Pre-operation Inspection is essential to safe machine operation. The Pre-operation Inspection is a visual inspection performed by the operator prior to each work shift. The inspection is designed to discover if anything is apparently wrong with a machine before the operator performs the function tests. The Pre-operation Inspection also serves to determine if routine maintenance procedures are required.

Complete information to perform this procedure is available in the appropriate operator's manual. Refer to the Operator's Manual on your machine.

### A-3

#### Check the Batteries



Proper battery condition is essential to good machine performance and operational safety. Improper fluid levels or damaged cables and connections can result in component damage and hazardous conditions.

**⚠ WARNING** Electrocution hazard.

Contact with hot or live circuits may result in death or serious injury. Remove all rings, watches and other jewelry.

**⚠ WARNING** Bodily injury hazard.

Batteries contain acid. Avoid spilling or contacting battery acid. Neutralize battery acid spills with baking soda and water.

- 1 Put on protective clothing and eye wear.
- 2 Be sure that the battery cable connections are tight and free of corrosion.
- 3 Be sure that the battery hold-down bars are secure.
- 4 Remove the battery vent caps.
- 5 Check the battery acid level. If needed, replenish with distilled water to the bottom of the battery fill tube. Do not overfill.
- 6 Install the vent caps.

**A-4****Check the Hydraulic Oil Level**

Maintaining the hydraulic oil at the proper level is essential to machine operation. Improper hydraulic oil levels can damage hydraulic components. Daily checks allow the inspector to identify changes in oil level that might indicate the presence of hydraulic system problems.

**NOTICE**

Perform this procedure with the platform in the stowed position and the engine off.

- 1 Visually inspect the sight of hydraulic oil level from the side of the hydraulic oil tank.
- ⊙ Result: The hydraulic oil level should be as marked on the tank.
- 2 Add oil if necessary. Do not overfill.

**Hydraulic oil specifications**

L-HV46

**A-5****Perform Function Tests**

Completing the function tests is essential to safe machine operation. Function tests are designed to discover any malfunctions before the machine is put into service. A malfunctioning machine must never be used. If malfunctions are discovered, the machine must be tagged and removed from service.

Complete information to perform this procedure is available in the appropriate operator's manual. Refer to the Operator's Manual on your machine.



## Maintenance

### A-6

#### Perform 30 Day Service



The 30 day maintenance procedure is a one time procedure to be performed after the first 30 days or 40 hours of usage. After this interval, refer to the maintenance tables for continued scheduled maintenance.

- 1 Perform the following maintenance procedures:
  - B-3 Inspect the Tires, Wheels and Castle Nut Torque
  - D-2 Replace the Hydraulic Tank Return Filter Element

### A-7

#### Grease the Steer Yokes



BALLYMORE/ DINGLI requires that this procedure be performed every 100 hours of operation.

Regular application of lubrication to the steer yokes is essential to good machine performance and service life. Continued use of an insufficiently greased steer yoke will result in component damage.

- 1 Open the steer yoke cover.
- 2 Locate the grease add hole on the top of the steer yoke.
- 3 Pump multipurpose grease into the steer yoke until the steer yoke is full and grease is being forced past the bearings.
- 4 Install the cover.
- 5 Repeat this step for the other steer yoke.

---

#### Grease Specification

---

Chevron Ultra-duty grease, EP NLGI 1 (lithium based) or equivalent

---

## Checklist B Procedures

### B-1

#### Inspect the Batteries



BALLYMORE/ DINGLI requires that this procedure be performed every 250 hours or quarterly, whichever comes first.

Proper battery condition is essential to good machine performance and operational safety. Improper fluid levels or damaged cables and connections can result in component damage and hazardous conditions.

**⚠ WARNING** Electrocuting / burn hazard. Contact with electrically charged circuits could result in death or serious injury. Remove all rings, watches and other jewelry.

**⚠ WARNING** Bodily injury hazard. Batteries contain acid. Avoid spilling or contacting battery acid. Neutralize battery acid spills with baking soda and water.

- 1 Put on protective clothing and eye wear.
- 2 Release the battery pack latch and rotate the battery pack out and away from the chassis.
- 3 Be sure that the battery cable connections are free of corrosion.

Note: Adding terminal protectors and a corrosion preventative sealant will help eliminate corrosion on the battery terminals and cables.

- 4 Be sure that the battery retainers and cable connections are tight.
- 5 Fully charge the batteries. Allow the batteries to rest 24 hours before performing this procedure to allow the battery cells to equalize.

#### Models without maintenance-free or sealed batteries:

- 6 Remove the battery vent caps and check the specific gravity of each battery cell with a hydrometer. Note the results.
- 7 Check the ambient air temperature and adjust the specific gravity reading for each cell as follows:
  - Add 0.004 to the reading of each cell for every 10° / 5.5°C above 80°F / 26.7°C.
  - Subtract 0.004 from the reading of each cell for every 10° / 5.5°C below 80°F / 26.7°C.
- ⊙ Result: All battery cells display an adjusted specific gravity of 1.277 or higher. The battery is fully charged. Proceed to step 11.
- ⊗ Result: One or more battery cells display a specific gravity of 1.217 or below. Proceed to step 8.
- 8 Perform an equalizing charge OR fully charge the batteries and allow the batteries to rest at least 6 hours.
- 9 Remove the battery vent caps and check the specific gravity of each battery cell with a hydrometer. Note the results.
- 10 Check the ambient air temperature and adjust the specific gravity reading for each cell as follows:
  - Add 0.004 to the reading of each cell for every 10° / 5.5°C above 80°F / 26.7°C.
  - Subtract 0.004 from the reading of each cell for every 10° / 5.5°C below 80°F / 26.7°C.

## Maintenance

- ⊙ Result: All battery cells display a specific gravity of 1.277 or greater. The battery is fully charged. Proceed to step 11.
  - ⊗ Result: The difference in specific gravity readings between cells is greater than 0.1 OR the specific gravity of one or more cells is less than 1.177. Replace the battery.
- 11 Check the battery acid level. If needed, replenish with distilled water to 0.1 in / 3 mm below the bottom of the battery fill tube. Do not overfill.
  - 12 Install the vent caps and neutralize any electrolyte that may have spilled.

### For DSL-40

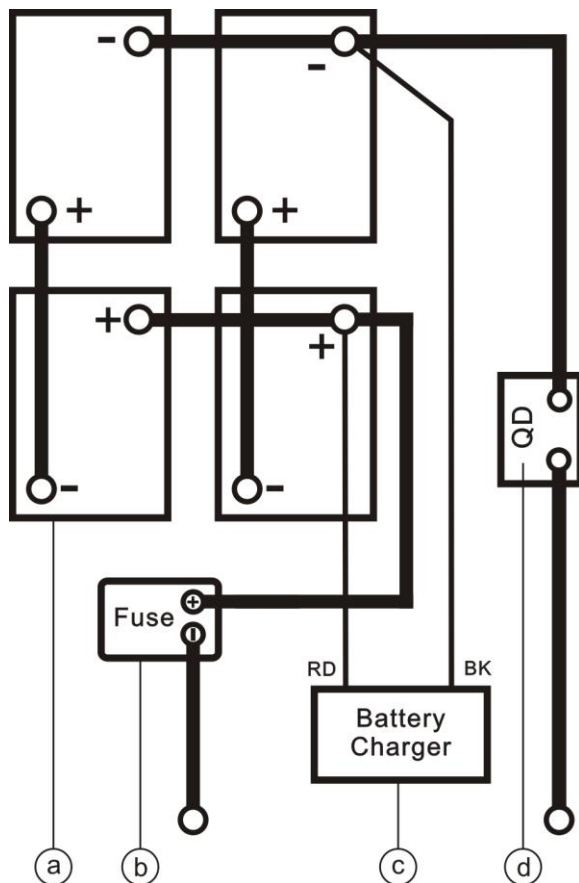

- a batteries
- b 300A fuse
- c battery charger
- d quick disconnect

### All models:

- 13 Check each battery pack and verify that the batteries are wired correctly.
  - 14 Inspect the battery charger plug and pigtail for damage or excessive insulation wear. Replace as required.
  - 15 Connect the battery charger to a properly grounded 110 - 230V / 50 - 60 Hz single phase AC power supply.
- ⊙ Result: The charger should operate and begin charging the batteries.
  - ⊗ Result: If, simultaneously, the charger alarm sounds and the LEDs blink, correct the charger connections at the fuse and battery. The charger will then operate correctly and begin charging the batteries.

Note: For best results, use an extension of adequate size with a length no longer than 50 ft / 15 m.

Note: If you have any further questions regarding the battery charger operation, please contact the BALLYMORE Service Department.

**Maintenance****B-2****Inspect the Electrical Wiring**

BALLYMORE/ DINGLI requires that this procedure be performed every 250 hours or quarterly, whichever comes first.

Maintaining electrical wiring in good condition is essential to safe operation and good machine performance. Failure to find and replace burnt, chafed, corroded or pinched wires could result in unsafe operating conditions and may cause component damage.

**⚠ WARNING** Electrocutation / burn hazard. Contact with electrically charged circuits could result in death or serious injury. Remove all rings, watches and other jewelry.

- 1 Inspect the underside of the chassis for damaged or missing ground strap(s).
- 2 Inspect the following areas for burnt, chafed, corroded and loose wires:
  - Ground control panel
  - Hydraulic power unit module tray
  - Battery pack module tray
  - Platform controls
- 3 Turn the red Emergency Stop button clockwise to the on position at both the ground and platform controls.
- 4 Raise the platform approximately 8.2 ft / 2.5 m from the ground.
- 5 Lift the safety arm, move it to the center of the scissor arm and rotate up to a vertical position.
- 6 Lower the platform onto the safety arm.

**⚠ WARNING** Crushing hazard. Keep hands clear of the safety arm when lowering the platform.

- 7 Inspect the center chassis area and scissor arms for burnt, chafed and pinched cables.
- 8 Inspect the following areas for burnt, chafed, corroded, pinched and loose wires:
  - Scissor arms
  - ECU to platform controls
  - Power to platform wiring
- 9 Inspect for a liberal coating of dielectric grease in the following locations:
  - Between the ECU and platform controls
  - All wire harness connectors Level sensor
- 10 Raise the platform and return the safety arm to the stowed position.
- 11 Lower the platform to the stowed position and turn the machine off.

## Maintenance

### B-3

#### Inspect the Tires and Wheels (including castle nut torque)



BALLYMORE/ DINGLI requires that this procedure be performed every 250 hours or quarterly, whichever comes first.

Maintaining the tires and wheels in good condition is essential to safe operation and good performance. Tire and/or wheel failure could result in a machine tip-over. Component damage may also result if problems are not discovered and repaired in a timely fashion.

- 1 Check the tire surface and sidewalls for cuts, cracks, punctures and unusual wear.
- 2 Check each wheel for damage, bends and cracks.
- 3 Remove the cotter pin and check each castle nut for proper torque.

Note: Always replace the cotter pin with a new one when removing the castle nut or when checking the torque of the castle nut.

- 4 Install a new cotter pin. Bend the cotter pin to lock it in place.

Castle nut torque, dry	300 ft-lbs 406.7 Nm
Castle nut torque, lubricated	225 ft-lbs 305 Nm

#### For DSL-40

Check each bolt for proper torque.

Bolt torque, dry	38 ft-lbs 50.5 Nm
Bolt torque, lubricated	27.9 ft-lbs 37.8Nm

### B-4

#### Test the Emergency Stop

BALLYMORE/ DINGLI requires that this procedure be performed every 250 hours or quarterly, whichever comes first.

A properly functioning Emergency Stop is essential for safe machine operation. An improperly operating red Emergency Stop button will fail to shut off power and stop all machine functions, resulting in a hazardous situation.

As a safety feature, selecting and operating the ground controls will override the platform controls, except the platform red Emergency Stop button.

- 1 Turn the key switch to ground control and turn the red Emergency Stop button clockwise to the on position at both the ground and platform controls.
  - 2 Push in the red Emergency Stop button at the ground controls to the off position.
- ⊙ Result: No machine functions should operate.
- 3 Turn the key switch to platform control and turn the red Emergency Stop button clockwise to the on position at both the ground and platform controls.
  - 4 Push in the red Emergency Stop button at the platform controls to the off position.
- ⊙ Result: No machine functions should operate.

Note: The red Emergency Stop button at the ground controls will stop all machine operation, even if the key switch is switched to platform control.

**Maintenance****B-5****Test the Key Switch**

BALLYMORE/ DINGLI requires that this procedure be performed every 250 hours or quarterly, whichever comes first.

Proper key switch action and response is essential to safe machine operation. The machine can be operated from the ground or platform controls and the activation of one or the other is accomplished with the key switch. Failure of the key switch to activate the appropriate control panel could cause a hazardous operating situation.

Perform this procedure from the ground using the platform controls. Do not stand in the platform.

- 1 Turn the red Emergency Stop button clockwise to the on position at both the ground and platform controls.
- 2 Turn the key switch to platform control.
- 3 Check the platform up/down function from the ground controls.

⊙ Result: The machine functions should not operate.

- 4 Turn the key switch to ground control.
- 5 Check the machine functions from the platform controls.

⊙ Result: The machine functions should not operate.

- 6 Turn the key switch to the off position.

⊙ Result: No function should operate.

**B-6****Test the Automotive-style Horn (if equipped)**

BALLYMORE/DINGLI requires that this procedure be performed every 250 hours or quarterly, whichever comes first.

The horn is activated at the platform controls and sounds at the ground as a warning to ground personnel. An improperly functioning horn will prevent the operator from alerting ground personnel of hazards or unsafe conditions.

- 1 Turn the key switch to platform control and turn the red Emergency Stop button clockwise to the on position at both the ground and platform controls.
- 2 Push down the horn button at the platform controls.

⊙ Result: The horn should sound.

## Maintenance

### B-7

#### Test the Drive Brakes



BALLYMORE/ DINGLI requires that this procedure be performed every 250 hours or quarterly, whichever comes first.

Proper brake action is essential to safe machine operation. The drive brake function should operate smoothly, free of hesitation, jerking and unusual noise.

Hydraulically-released individual wheel brakes can appear to operate normally when not fully operational.

Perform this procedure with the machine on a firm level surface that is free of obstructions, with the platform extension deck fully retracted and the platform in the stowed position.

- 1 Mark a test line on the ground for reference.
- 2 Turn the key switch to platform control and turn the red Emergency Stop button clockwise to the on position at both the ground and platform controls.
- 3 Lower the platform to the stowed position.
- 4 Press the drive function select button.

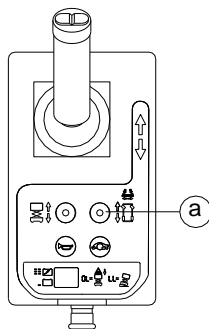

a drive function select button

- 5 Choose a point on the machine; i.e., contact patch of a tire, as a visual reference for use when crossing the test line.
  - 6 Bring the machine to top drive speed before reaching the test line. Release the function enable switch or the joystick when your reference point on the machine crosses the test line.
  - 7 Measure the distance between the test line and your machine reference point.
- ⊙ Result: The machine stops within the specified braking distance. No action required.

⊗ Result: The machine does not stop within the specified braking distance.

Note: The brakes must be able to hold the machine on any slope it is able to climb.

- 8 Replace the brakes and repeat this procedure beginning with step 1.

---

#### Braking distance, maximum

---

High range on paved surface	24 in±11.8 in 61 cm±30 cm
-----------------------------	------------------------------

---

**Maintenance****B-8****Test the Drive Speed - Stowed Position**

BALLYMORE/ DINGLI requires that this procedure be performed every 250 hours or quarterly, whichever comes first.

Proper drive functions are essential to safe machine operation. The drive function should respond quickly and smoothly to operator control. Drive performance should also be free of hesitation, jerking and unusual noise over the entire proportionally controlled speed range.

Perform this procedure with the machine on a firm, level surface that is free of obstructions.

- 1 Create start and finish lines by marking two lines on the ground 40 ft / 12.2 m apart.
- 2 Turn the key switch to platform control and turn the red Emergency Stop button clockwise to the on position at both the ground and platform controls.
- 3 Lower the platform to the stowed position.
- 4 Press the drive function select button.
- 5 Choose a point on the machine; i.e., contact patch of a tire, as a visual reference for use when crossing the start and finish lines.
- 6 Bring the machine to top drive speed before reaching the start line. Begin timing when your reference point on the machine crosses the start line.
- 7 Continue at full speed and note the time when your reference point on the machine passes over the finish line. Refer to specifications.

**B-9****Test the Drive Speed - Raised Position**

BALLYMORE/ DINGLI requires that this procedure be performed every 250 hours or quarterly, whichever comes first.

Proper drive functions are essential to safe machine operation. The drive function should respond quickly and smoothly to operator control. Drive performance should also be free of hesitation, jerking and unusual noise over the entire proportionally controlled speed range.

Perform this procedure with the machine on a firm, level surface that is free of obstructions.

- 1 Create start and finish lines by marking two lines on the ground 40 ft / 12.2 m apart.
- 2 Turn the key switch to platform control and turn the red Emergency Stop button clockwise to the on position at both the ground and platform controls.
- 3 Press the lift function select button.

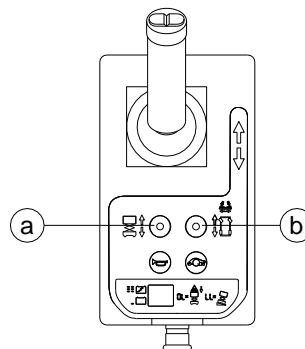

- a lift function select button  
b drive function select button



## Maintenance

- 4 Press and hold the function enable switch on the joystick.
- 5 Raise the platform approximately 6.6 ft / 2 m from the ground.
- 6 Press the drive function select button.
- 7 Choose a point on the machine; i.e., contact patch of a tire, as a visual reference for use when crossing the start and finish lines.
- 8 Bring the machine to top drive speed before reaching the start line. Begin timing when your reference point on the machine crosses the start line.
- 9 Continue at full speed and note the time when your reference point on the machine passes over the finish line. Refer to specifications.

### B-10

#### Test the Slow Drive Speed



BALLYMORE/ DINGLI requires that this procedure be performed every 250 hours or quarterly, whichever comes first.

Proper drive functions are essential to safe machine operation. The drive function should respond quickly and smoothly to operator control. Drive performance should also be free of hesitation, jerking and unusual noise over the entire proportionally controlled speed range.

Perform this procedure with the machine on a firm, level surface that is free of obstructions.

- 1 Create start and finish lines by marking two lines on the ground 40 ft / 12.2 m apart.
- 2 Turn the key switch to platform control and turn the red Emergency Stop button clockwise to the on position at both the ground and platform controls.
- 3 Lower the platform to the stowed position.
- 4 Press the slow speed select button.

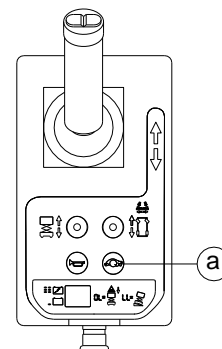

a slow speed select button

## Maintenance

- 5 Choose a point on the machine; i.e., contact patch of a tire, as a visual reference for use when crossing the start and finish lines.
- 6 Bring the machine to top drive speed before reaching the start line. Begin timing when your reference point on the machine crosses the start line.
- 7 Continue at full speed and note the time when your reference point on the machine passes over the finish line. The time is less than 25 sec.

### B-11

#### Perform Hydraulic Oil Analysis



BALLYMORE/ DINGLI requires that this procedure be performed every 250 hours or quarterly, whichever comes first.

Replacement or testing of the hydraulic oil is essential for good machine performance and service life. Dirty oil may cause the machine to perform poorly and continued use may cause component damage. Extremely dirty conditions may require oil changes to be performed more often.

Before replacing the hydraulic oil, the oil may be tested by an oil distributor for specific levels of contamination to verify that changing the oil is necessary.

If the hydraulic oil is not replaced at the two year inspection, test the oil quarterly. Replace the oil when it fails the test. See E-1, Test or Replace the Hydraulic Oil.

## Maintenance

### B-12

#### Inspect the Hydraulic Tank Cap Venting System



BALLYMORE/ DINGLI requires that this procedure be performed quarterly or every 250 hours, whichever comes first. Perform this procedure more often if dusty conditions exist.

A free-breathing hydraulic tank cap is essential for good machine performance and service life. A dirty or clogged cap may cause the machine to perform poorly. Extremely dirty conditions may require that the cap be inspected more often.

- 1 Remove the breather cap from the hydraulic tank.
- 2 Check for proper venting.
  - ⊙ Result: Air passes through the breather cap.
  - ⊖ Result: If air does not pass through the cap, clean or replace the cap. Proceed to step 3.

Note: When checking for positive tank cap venting, air should pass freely through the cap.

- 3 Using a mild solvent, carefully wash the cap venting system. Dry using low pressure compressed air. Repeat step 2.
- 4 Install the breather cap onto the hydraulic tank.

### B-13

#### Check the Module Tray Latch Components



BALLYMORE/ DINGLI requires that this procedure be performed every 250 hours or quarterly, whichever comes first.

Maintaining the module tray latch components in good condition is essential to good performance and service life. Failure to detect worn out latch components may result in module trays opening unexpectedly, creating an unsafe operating condition.

- 1 Inspect each module tray rotary latch and related components for wear. Tighten any loose fasteners.
- 2 Lubricate each module tray rotary latch. Using light oil, apply a few drops to each of the springs and to the sides of the rotary latch mechanism.

**B-14****Test the Down Limit Switch and the Pothole Limit Switches**

BALLYMORE/ DINGLI requires that this procedure be performed every 250 hours or quarterly, whichever comes first.

Maintaining the limit switches is essential to safe operation and good machine performance. Operating the machine with a faulty limit switch could result in reduced machine performance and a potentially unsafe operating condition.

Perform these procedures with the machine on a firm, level surface that is free of obstructions.

**Down Limit Switch**

- 1 Remove the platform controls from the platform.
  - 2 Raise the platform approximately 8.2 ft / 2.5 m from the ground.
  - 3 Lift the safety arm, move it to the center of the scissor arm and rotate up to a vertical position.
  - 4 Lower the platform onto the safety arm.
- ▲ WARNING** Crushing hazard. Keep hands clear of the safety arm when lowering the platform.
- 5 Turn the key switch to the off position.
  - 6 Tag and disconnect the platform control box at the platform.
  - 7 Follow the platform control cable down the scissor stack to the underside of the chassis deck. Tag and disconnect the platform cable from the ECU cable at the 6-pin Deutsch connector under the chassis deck.

- 8 Securely install the platform control box harness plug into the 6-pin Deutsch connector of the ECU cable.
- 9 Open the down limit switch cover, tag and disconnect the wires of the down limit switch wire harness.
- 10 Turn the key switch to platform control.
- 11 Raise the platform and return the safety arm to the stowed position.
- 12 Working at the platform controls, press the lift function select button. Lower the platform to the stowed position.
  - ⊙ Result: The diagnostic display will show code 18, an alarm sounds and the lift function should operate. The machine is functioning properly.
  - ⊗ Result: The diagnostic display does not show code 18, the alarm does not sound and the lift function should not operate. Replace the down limit switch.
- 13 Press the drive function select button. Attempt to drive the machine.
  - ⊙ Result: The diagnostic display will show code 18, an alarm sounds, and the steer and drive functions should not operate. The machine is functioning properly.
  - ⊗ Result: The diagnostic display does not show code 18, the alarm does not sound, and the steer and drive functions operate. Replace the down limit switch.
- 14 Press the lift function select button. Raise the platform approximately 11.8 in / 0.3 m.
  - ⊙ Result: The diagnostic display will show code 18 and an alarm sounds. The

## Maintenance

machine is functioning properly.

- ⊗ Result: The diagnostic display does not show code 18 and the alarm does not sound. Replace the down limit switch.
- 15 Raise the platform until the pothole guards are deployed.
- ⊙ Result: The diagnostic display does not show code 18 and the alarm does not sound. The machine is functioning properly.
- ⊗ Result: The diagnostic display shows code 18 and an alarm sounds. Replace the down limit switch.
- 16 Raise the platform approximately 8.2 ft / 2.5 m from the ground.
- 17 Lift the safety arm, move it to the center of the scissor arm and rotate up to a vertical position.
- 18 Lower the platform onto the safety arm.
- ⚠ WARNING** Crushing hazard. Keep hands clear of the safety arm when lowering the platform.
- 19 Turn the key switch to the off position.
- 20 Disconnect the platform controls from the ECU cable.
- 21 Securely install the connector of the ECU cable into the platform control cable.
- 22 Working at the platform, securely install the connector of the platform controls into the platform control cable.
- 23 Securely connect the two wires of the down limit switch to wire harness.
- 24 Close and install the switch cover.
- 25 Turn the key switch to platform control.
- 26 Raise the platform and return the safety arm to the stowed position.
- 27 Lower the platform to the stowed position.

### Pothole Limit Switches

- 28 Move the machine onto a grade which exceeds the rating of the level sensor. Refer to the serial label on the machine.
- 29 Press the lift function select button. Standing on the up-hill side of the machine, attempt to raise the platform to approximately 6.6 ft / 2 m.
- ⊙ Result: The alarm sounds, and the machine stops lifting after the pothole guards are deployed. The machine is functioning properly.
- ⊗ Result: The alarm does not sound and the machine will continue to lift the platform after the pothole guards are deployed. Adjust or replace the pothole limit switch.
- 30 Press the drive function select button. Standing on the up-hill side of the machine, attempt to steer and drive the machine.
- ⊙ Result: The alarm sounds. The machine is functioning properly.
- ⊗ Result: The alarm does not sound. Adjust or replace the pothole limit switch.
- 31 Lower the platform to the stowed position. Move the machine onto a firm, level surface.
- 32 Place a wooden block approximately 2 in / 5 cm tall under the right pothole guard.
- 33 Press the lift function select button. Attempt to raise the platform approximately 6.6 ft / 2 m.
- ⊙ Result: The pothole guard contacts the block and does not fully deploy, the diagnostic display shows code 18, an alarm sounds and the platform will lift to 6.6 ft / 2m or beyond. The machine is functioning properly.
- ⊗ Result: The pothole guard contacts the block and does not fully deploy, the

## Maintenance

diagnostic display does not show code 18, the alarm does not sound and the machine will continue to lift the platform after the pothole guards are deployed. Adjust or replace the pothole limit switch.

- 34 Press the drive function select button. Attempt to steer or drive the machine.
  - ☉ Result: The diagnostic display shows code 18, an alarm sounds, and the machine will not steer or drive. The machine is functioning properly.
  - ☒ Result: The diagnostic display does not show code 18, the alarm does not sound and the steer and drive functions operate. Adjust or replace the down limit switch.
- 35 Lower the platform to the stowed position and remove the block under the right pothole guard.
- 36 Repeat this procedure beginning with step 31 for the left pothole guard.
- 37 Lower the platform to the stowed position, remove the block under the left pothole guard.
- 38 Turn off the machine.

### B-15

#### Test the Up Limit Switch



BALLYMORE/ DINGLI requires that this procedure be performed every 250 hours or quarterly, whichever comes first.

Maintaining the limit switches is essential to safe operation and good machine performance.

Operating the machine with a faulty limit switch could result in reduced machine performance and a potentially unsafe operating condition.

Perform these procedures with the machine on a firm, level surface that is free of obstructions.

- 1 Turn the key switch to ground control and raise the platform approximately 8.2 ft / 2.5m from the ground.
- 2 Lift the safety arm, move it to the center of the scissor arm and rotate the safety arm away from the machine and let it hang down.
- 3 Lower the platform onto the safety arm.

**⚠ WARNING** Crushing hazard. Keep hands clear of the safety arm when lowering the platform.

- 4 Open the limited switch house cover from the chassis.
- 5 While raising the platform from the ground controls, push in the roller of the up limit switch to activate the limit switch.

☉ Result: The platform stops raising. The machine is functioning properly.

☒ Result: The platform continues to raise. Adjust or replace the up limit switch.

- 6 Install the limited switch house cover to chassis.
- 7 Put the safe arm to home position.
- 8 Lower the platform to the stowed position.

## Maintenance

### Checklist C Procedures

#### C-1

#### Test the Platform Overload System (if equipped)



BALLYMORE/ DINGLI requires that this procedure be performed every 500 hours or six months, whichever comes first OR when the machine fails to lift the maximum rated load.

Testing the platform overload system regularly is essential to safe machine operation.

Continued use of an improperly operating platform overload system could result in the system not sensing an overloaded platform condition. Machine stability could be compromised resulting in the machine tipping over.

The platform overload system is designed to prevent machine operation in the event the platform is overloaded. Models equipped with the platform overload option are provided with two additional machine control components: the overload pressure switch and a tilt sensor.

The overload pressure switch, which is adjustable and located at the barrel-end of the lift cylinder, is used to determine when the hydraulic lift cylinder requires too much pressure to support the load inside the platform. When this occurs, the pressure switch will send a signal to the ECU, which will not allow the machine to function until the extra weight is removed from the platform.

The tilt sensor, located in the inner scissor arm 1, is used to determine the tilt of scissor, than to measure the height of platform.

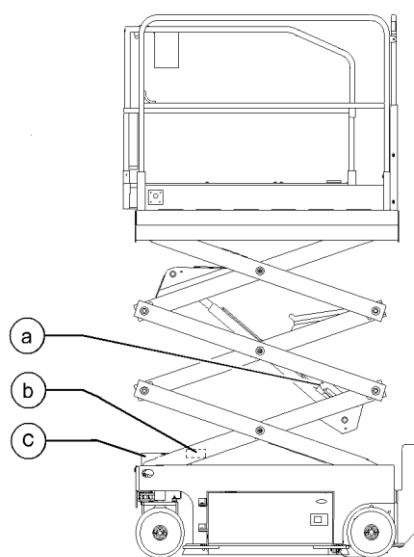

- a overload pressure switch
- b tilt sensor
- c limited switch cover

- 1 Turn the key switch to ground control and raise the platform approximately 8.2 ft / 2.5 m from the ground.
- 2 Lift the safety arm, move it to the center of the scissor arm and rotate the safety arm away from the machine and let it hang down.
- 3 Lower the platform onto the safety arm.

**⚠ WARNING** Crushing hazard. Keep hands clear of the safety arm when lowering the platform.

- 4 Open the limited switch house cover from the chassis.
- 5 Open the up limited switch cover.

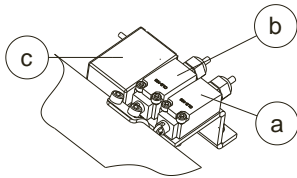
**Maintenance**

- a up limited switch
- b down limited switch
- c slope sensor

- 6 Tag and disconnect the wires of the up limit switch wire harness.
- 7 Securely connect together the terminals of the two wires of the up limit switch.
- 8 Turn the key switch to ground control and turn the red Emergency Stop button clockwise to the on position at both the ground and platform controls.
- 9 Raise the platform to release the safe arm.
- 10 Put the safe arm to home position.
- 11 Fully raise the platform. Release the toggle switch.
  - Result: The alarm should sound.
  - Result: The alarm does not sound.  
Calibrate the platform overload system.
- 12 Using the manual lowering knob, lower the platform to the stowed position.
- 13 Securely connect the wires of the up limit switch.
- 14 Fully raise the platform. Release the toggle switch.
  - Result: The alarm should not sound. The system is functioning correctly.
  - Result: The alarm sounds. The system is not functioning correctly. Troubleshoot the limit switch, limit switch wire harness or limit switch mount bracket or the platform overload system needs to be calibrated.
- 15 Lower the platform approximately 8.2 ft / 2.5 m from the ground.

16 Lift the safety arm, move it to the center of the scissor arm and rotate the safety arm away from the machine and let it hang down.

17 Lower the platform onto the safety arm.

**⚠ WARNING** Crushing hazard. Keep hands clear of the safety arm when lowering the platform.

18 Install the up limited switch cover.

19 Install the limited switch house cover.

20 Raise the platform to release the safe arm.

21 Put the safe arm to home position.

22 Lower the platform to the stowed position.



## Maintenance

### C-2

#### Replace the Hydraulic Tank Breather Cap



BALLYMORE/ DINGLI requires that this procedure be performed every 500 hours or semi-annually, whichever comes first.

The hydraulic tank is a vented-type tank. The breather cap has an internal air filter that can become clogged or, over time, can deteriorate. If the breather cap is faulty or improperly installed, impurities can enter the hydraulic system which may cause component damage. Extremely dirty conditions may require that the cap be inspected more often.

- 1 Remove and discard the hydraulic tank breather cap.
- 2 Install a new cap onto the tank.

**Checklist D Procedures****D-1****Check the Scissor Arm Wear Pads**

BALLYMORE/ DINGLI requires that this procedure be performed every 1000 hours or annually, whichever comes first.

Maintaining the condition of the scissor arm wear pads is essential to safe machine operation. Continued use of worn out wear pads may result in component damage and unsafe operating conditions.

Perform this procedure with the platform in the stowed position.

- 1 Measure the distance between the number one inner arm cross tube and the chassis deck at the ground controls side of the non-steer end of the machine.

Refer to illustration below.

☉ Result: The measurement is 1.34 in / 34mm or more. Proceed to step 2.

☒ Result: The measurement is less than 1.34 in / 34 mm. Replace both wear pads.

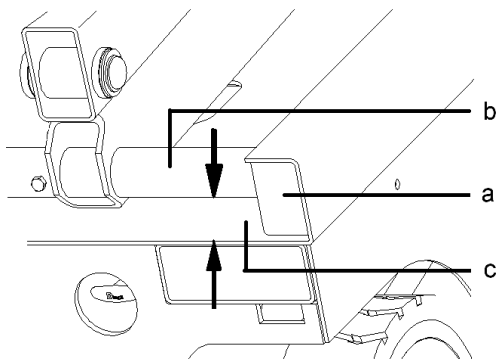

- a wear pad
- b inner arm cross tube
- c chassis deck

- 2 Measure the distance between the number one inner arm cross tube and the chassis deck at the battery pack side of the non-steer end of the machine.

Refer to illustration below.

☉ Result: The measurement is 1.34 in /34 mm or more. Proceed to step 3.

☒ Result: The measurement is less than 1.34 in / 34 mm. Replace both wear pads.

- 3 Apply a thin layer of dry film lubricant to the area of the chassis where the scissor arm wear pads make contact.

## Maintenance

### D-2

#### Replace the Hydraulic Tank Return Filter Element



BALLYMORE/ DINGLI requires that this procedure be performed every 1000 hours or annually, whichever comes first.

Replacement of the hydraulic tank return filter is essential for good machine performance and service life. A dirty or clogged filter may cause the machine to perform poorly and continued use may cause component damage. Extremely dirty conditions may require that the filter be replaced more often.

**⚠ CAUTION** Beware of hot oil. Contact with hot oil may cause severe burns.

**NOTICE** The hydraulic tank return filter is mounted on the bracket between the function manifold and the hydraulic power unit.

- 1 Clean the area around the oil filter.  
Remove the filter with an oil filter wrench.
- 2 Apply a thin layer of oil to the new oil filter gasket.
- 3 Install the new filter and tighten it securely by hand.
- 4 Use a permanent ink marker to write the date and number of hours from the hour meter onto the filter.
- 5 Turn the key switch to ground control and turn the red Emergency Stop button clockwise to the on position at both the ground and platform controls.
- 6 Activate and hold the platform up toggle switch.
- 7 Inspect the filter and related components to be sure that there are no leaks.
- 8 Clean up any oil that may have spilled.

## Checklist E Procedure

### E-1

#### Test or Replace the Hydraulic Oil



BALLYMORE/ DINGLI requires that this procedure be performed every 2000 hours or every two years, whichever comes first.

Replacement or testing of the hydraulic oil is essential for good machine performance and service life. Dirty oil may cause the machine to perform poorly and continued use may cause component damage. Extremely dirty conditions may require oil changes to be performed more often.

Before replacing the hydraulic oil, the oil may be tested by an oil distributor for specific levels of contamination to verify that changing the oil is necessary.

If the hydraulic oil is not replaced at the two year inspection, test the oil quarterly. Replace the oil when it fails the test.

Note: Perform this procedure with the platform in the stowed position.

- 1 Disconnect the battery pack from the machine.

**⚠ WARNING** Electrocutation / burn hazard: Contact with electrically charged circuits could result in death or serious injury. Remove all rings, watches and other jewelry.

- 2 Open the power unit module tray.
- 3 Tag and disconnect the hydraulic tank return line from the hydraulic filter head and remove the line from the tank. Cap the fitting on the filter head.
- 4 Tag and disconnect the hydraulic pump inlet line and remove the line from the tank. Cap the fitting on the pump.

- 5 Remove the hydraulic tank retaining fasteners and remove the hydraulic tank from the machine.
- 6 Remove the oil drain plug at bottom.
- 7 Drain all of the oil into a suitable container..

**⚠ WARNING** Bodily injury hazard.

Spraying hydraulic oil can penetrate and burn skin. Loosen hydraulic connections very slowly to allow the oil pressure to dissipate gradually. Do not allow oil to squirt or spray.

- 8 Clean up any oil that may have spilled. Properly discard the used oil.
- 9 Clean the inside of the hydraulic tank using a mild solvent. Allow the tank to dry completely.
- 10 Tighten the drain plug. Torque to specification.

---

#### Torque specifications

Hydraulic tank drain plug, dry	10 in-lbs 4.5 Nm
Hydraulic tank drain plug, lubricated	30 in-lbs 3.4 Nm

- 11 Install the hydraulic tank and install and tighten the hydraulic tank retaining fasteners. Torque to specification.

---

#### Torque specifications

Hydraulic tank retaining fasteners, dry	35 in-lbs 4 Nm
Hydraulic tank drain plug, lubricated	26 in-lbs 2.9 Nm

## Maintenance

- 12 Install the hydraulic pump inlet line into the tank. Install the fitting onto the pump and torque.
- 13 Install the hydraulic pump return line into the tank. Install the fitting onto the hydraulic filter head and torque.
- 14 Fill the tank with hydraulic oil until the fluid is full in the hydraulic tank. Do not overfill.
- 15 Activate the pump to fill the hydraulic system with oil and bleed the system of air.

**⚠ WARNING** Component damage hazard.  
The pump can be damaged if operated without oil. Be careful not to empty the hydraulic tank while in the process of filling the hydraulic system. Do not allow the pump to cavitate.



# Schematic

## DSL-40

