



**GREEN MACHINE®**

**e210R**  
ELECTRIC COMPACT EXCAVATOR



[www.greenmachineco.com](http://www.greenmachineco.com)

1001 East Delavan Avenue, Buffalo, NY 14215



**GREEN MACHINE®**

**e210R**  
ELECTRIC COMPACT EXCAVATOR



[www.greenmachineco.com](http://www.greenmachineco.com)

1001 East Delavan Avenue, Buffalo, NY 14215



# GREEN MACHINE®

## e210R

ELECTRIC COMPACT EXCAVATOR

## PRODUCT FEATURES & SPECIFICATIONS

### OPERATING PERFORMANCE

Operating Weight	2,370 lb	(1,075 kg)
Max. Bucket Breakout Force	2,518 lb	(1,142 kg)
Max. Arm Digging Force	1,439 lb	(653 kg)
Arm Length	2 ft 10.6 in	(880 mm)
Slew Speed	10.0 rpm	
Traction Force	2,878 lb	(1,305 kg)
Ground Pressure	4.1 psi	
Max. Travel Speed		
Low Range	1.2 mph	(2 km/hr)
High Range	2.3 mph	(3.7 km/hr)

### HYDRAULIC

Total Hydraulic Flow	5.9 gal/min	(22.2 L/min)
Auxiliary Hydraulic Flow	5.9 gal/min	(22.2 L/min)
System Operating Pressure	2,680 psi	(18.2 mpa)

### MOTOR

Horsepower @ 3500 rpm	23.1 hp	(17.2 kW)
Torque @ 0 rpm	40.3 ft-lb	(54.6 Nm)

### FLUID CAPACITIES

Hydraulic Reservoir Capacity	2.3 gal	(9.0 L)
Hydraulic System Capacity	4.0 gal	(15.0 L)



**DUAL  
SIDE ENTRY**



**FOLDABLE  
ROPS**



**RETRACTABLE  
UNDERCARRIAGE  
AND BLADE**



**EASY  
SERVICEABILITY**



[www.greenmachineco.com](http://www.greenmachineco.com)

1001 East Delavan Avenue, Buffalo, NY 14215



# GREEN MACHINE®

**e210R**  
ELECTRIC COMPACT EXCAVATOR

## MOTOR

- Zero Emissions
- 3-Phase AC Brushless
- Variable Frequency Drive
- Dial Operated Electronic Speed Control
- Flat Torque Curve from 0 RPM

## WORKING EQUIPMENT

- Top Mount Boom Cylinder
- Minimal Tail Swing
- Long Arm
- Hydraulics Lines Protected in Boom and Arm
- Boom Swing 850 Left & Right
- Cushioned Boom Cylinder
- Dual Pin Position Bucket (optional)

## BATTERY

- High Capacity Lithium Ion
- 12.8 kWh
- Sophisticated Battery Management System
- Stainless Steel Case
- Waterproof/Dustproof

## HYDRAULIC

- Pilot Operated Joystick Controls
- Tandem Gear Pumps
- Auxiliary Hydraulic Circuit Plumbed to Arm
- Selectable One-way and Two-way Auxiliary Operation

## UNDERCARRIAGE & FRAME

- Hydraulically Retractable Track Frame
- Low and High Range Travel
- Back II Blade with Pin-on Extensions
- Protective Counterweight

## ELECTRICAL

- Battery Level Display
- 12 Volt System With 15 Amp DC-DC Converter
- Boom Mounted Work Light
- Travel Alarm
- Hour Meter

## OPERATOR'S STATION

- ROPS / TOPS Two Post Foldable Frame
- Pattern Change Valve
- Foot Controlled Auxiliary Hydraulics
- 2" Retractable Seat Belt



[www.greenmachineco.com](http://www.greenmachineco.com)

1001 East Delavan Avenue, Buffalo, NY 14215



# GREEN MACHINE®

## e210R

ELECTRIC COMPACT EXCAVATOR

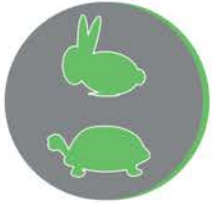

The e210R features many upgrades that will enhance operator comfort, efficiency, and serviceability. To improve fine control and reduce fatigue, the e210R now features pilot operated joystick controls that are low effort and responsive to operator input.

Additionally, an ISO/SAE pattern change valve has been added enabling the operator to choose their preferred operational pattern. The boom cylinder is now mounted on top of the boom for greater protection and improved routing of the hydraulic lines which are run through the boom and arm. A hydraulically retractable track frame and the addition of a foldable ROPS frame allow it to easily pass through a standard doorway.



To reduce the likelihood of rear swing impacts, the e210R also features a short tail swing design. Despite its compact dimensions, service access is exceptional thanks to the tilt-up seat pedestal and access panels.



**EASILY PASS  
THROUGH A  
STANDARD  
DOORWAY**



[www.greenmachineco.com](http://www.greenmachineco.com)

1001 East Delavan Avenue, Buffalo, NY 14215



# GREEN MACHINE®

## e210R

ELECTRIC COMPACT EXCAVATOR

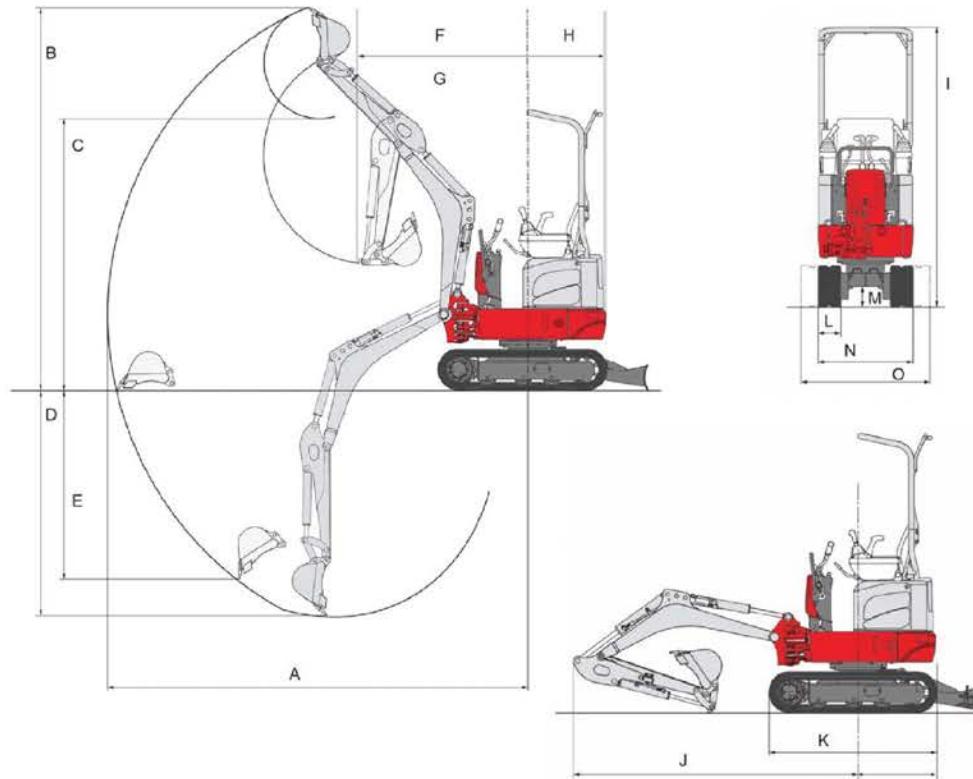

### MACHINE DIMENSIONS

A	Maximum Reach	10 ft 9.4 in	(3,285 mm)
B	Maximum Dig Height	9 ft 9.5 in	(2,985 mm)
C	Maximum Dump Height	6 ft 11.5 in	(2,120 mm)
D	Maximum Dig Depth	5 ft 9.1 in	(1,755 mm)
E	Maximum Vertical Dig Depth	4 ft 10 in	(1,475 mm)
F	Front Swing Radius	4 ft 4 in	(1,320 mm)
G	Front Swing Radius (Offset)	3 ft 2.5 in	(980 mm)
H	Tail Swing Radius	2 ft 0 in	(610 mm)
I	Transport Height	7 ft 2.2 in	(2,200 mm)
J	Transport Length	9 ft 8.3 in	(2,955 mm)
K	Undercarriage Length	4 ft 4.2 in	(1,325 mm)
L	Track Width	7.1 in	(180 mm)
M	Ground Clearance	6.2 in	(157 mm)
N	Track Width Retracted	29.5 in	(750 mm)
O	Track Width Extended	40.2 in	(1,020 mm)



[www.greenmachineco.com](http://www.greenmachineco.com)

1001 East Delavan Avenue, Buffalo, NY 14215



**GREEN MACHINE**<sup>®</sup>

**e210R**  
ELECTRIC COMPACT EXCAVATOR



[www.greenmachineco.com](http://www.greenmachineco.com)

1001 East Delavan Avenue, Buffalo, NY 14215



# GREEN MACHINE®

**e210R**  
ELECTRIC COMPACT EXCAVATOR



## CONTACT GREEN MACHINE



For sales & product info  
[sales@greenmachineco.com](mailto:sales@greenmachineco.com)  
716.968.8658 ext 201



For technical or  
safety questions  
[tech@greenmachineco.com](mailto:tech@greenmachineco.com)  
716.968.8658 ext 200



For business development  
or partnerships  
[biz@greenmachineco.com](mailto:biz@greenmachineco.com)  
716.968.8658 ext 200



[www.greenmachineco.com](http://www.greenmachineco.com)

1001 East Delavan Avenue, Buffalo, NY 14215