

*Hustler® TrimStar
Parts Manual*



HUSTLER®

ENGINEERING PERFORMANCE™

200 South Ridge Road
Hesston, Kansas
67062

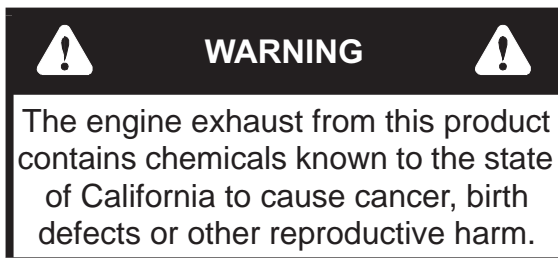

NOTICE OF REQUIREMENT OF SPARK ARRESTER MUFFLER

This equipment may create sparks that can start fires around dry vegetation. California Public Resources Code Section 4442.6 provides that it is unlawful to use or operate an internal combustion engine on any forest-covered, brush-covered, or grass-covered land unless the engine is equipped with a spark arrester maintained in effective working order. A spark arrester is a device constructed of nonflammable materials specifically for the purpose of removing and retaining carbon and other flammable particles over 0.0232 of an inch in size from the exhaust flow of an internal combustion engine that uses hydrocarbon fuels or which is qualified and rated by the United States Forest Service. Other states or federal areas may have similar laws. The Operator Should Contact Local Fire Agencies For Laws or Regulations Relating to Fire Prevention Requirements. **THIS EQUIPMENT DOES NOT HAVE A SPARK ARRESTER AND YOU SHOULD CONTACT YOUR AUTHORIZED DEALER FOR THE PURCHASE OF A SPARK ARRESTER.**

Inspect spark arrester daily; replace every 500 hours or as needed.

The Engine Owner's Manual provides information regarding the U.S. Environmental Protection Agency (EPA) and the California Emission Control Regulation of emission systems, maintenance and warranty.

Keep Engine Owner's Manual with your unit. Should the Engine Owner's Manual become damaged or illegible, replace immediately. Replacements may be ordered per the information found in the Product Information section of the owner's manual.

Federal law and California State law prohibit the following acts or the causing thereof:

1. The removal or rendering inoperative by any person other than for purposes of maintenance, repair, replacement, of any device or element of design incorporated into any equipment for the purposes of emissions control prior to or after its sales or delivery to the ultimate purchaser or while it is in use, or
2. The use of the equipment after such device or element of design has been removed or rendered inoperative by any person.

Table of Contents

General Information

Service Literature	1-1
Options Available From Your Dealer.....	1-1
Using This Manual	1-1
Hardware Description Codes & Abbreviations	1-2
Standard Torques	1-2

Section 2

36" Frame	2-2
48" Frame	2-4
54" Frame	2-6
36" Cover	2-8
48" & 54" Cover.....	2-10
Miscellaneous Decals—Models Ending in "US"	2-12

Section 3

36" Hydraulic System.....	3-2
36" Transmission Assembly	3-6
48" & 54" Hydraulic System—S/N 13014137 & Higher.....	3-12
48" & 54" Hydraulic System—S/N Prior to 13014137	3-16
48" & 54" Transmission Assembly	3-20
Transmission Service Parts	3-26
Handlebar.....	3-28
Throttle	3-30
Instrument Panel	3-32
Instrument Panel, Electric Start.....	3-40
36" Brake—S/N 13015041 & Higher	3-48
36" Brake—S/N Prior to 13015041	3-50
48" & 54" Brake—S/N 13014137 & Higher	3-52
48" & 54" Brake—S/N Prior to 13014137.....	3-54

Section 4

Wheel & Tire	4-2
Front Wheel Breakdown.....	4-4
Drive Wheel Breakdown.....	4-6

Section 5

Engine, Kawasaki FS481V.....	5-2
Fuel & Vapor Lines, Kawasaki FS481V	5-4
Engine, Kawasaki FS541V & FS600V	5-6
Fuel & Vapor Lines, Kawasaki FS541V & FS600V	5-8
Engine, Kawasaki FS691V.....	5-10
Fuel & Vapor Lines, Kawasaki FS691V	5-14
Kawasaki Engine Service Parts	5-16
Battery.....	5-18
36" Fuel System w/o Carb. Canister—S/N 12081093 & Higher	5-20
36" Fuel System w/o Carb. Canister—S/N Prior to 12081093.....	5-22
48/54" Fuel Sys. w/o Carb. Canister—S/N 12080674 & Higher	5-24

48/54" Fuel Sys. w/o Carb. Canister—S/N Prior to 12080674	5-26
Fuel Tank w/o Carbon Canister Service Parts	5-28
36" Fuel System with Carb. Canister—S/N 12111102 & Higher	5-30
36" Fuel System with Carb. Canister—S/N Prior to 12111102	5-32
48/54" Fuel Sys. w/ Carb. Canister—S/N 12080854 & Higher	5-34
48/54" Fuel Sys. w/ Carb. Canister—S/N Prior to 12080854	5-36
Fuel Tank With Carbon Canister Service Parts	5-38

Section 6

36" Service Deck	6-2
36" Deck Pulleys & Spindles	6-4
36" Deck	6-6
36" Deck Lift	6-8
36" Deck Mounting Hardware	6-10
48" Service Deck	6-12
48" Deck Pulleys & Spindles	6-14
48" Deck	6-16
54" Service Deck	6-18
54" Deck Pulleys & Spindles	6-20
54" Deck	6-22
48" & 54" Deck Lift	6-24
48" & 54" Deck Mounting Hardware	6-26
Spindle Service Parts	6-28

General Information

This Manual covers Trimstar models **930388, 930388US, 930388EX, 930396, 930396US, 930396EX, 930404, 930404EX, 930412 & 930412EX.**

Service Literature

PART NO.	DESCRIPTION
114510	OPERATOR'S MANUAL
114511	WARRANTY STATEMENT
114674	GENERAL SERVICE MANUAL

Options Available From Your Dealer

PART NO.	DESCRIPTION
929299	SIDE CATCHER ASSEMBLY
111478	36" ADAPTER KIT
111479	48" & 54" ADAPTER KIT
107654	36" MULCH KIT
108223	48" MULCH KIT
108197	54" MULCH KIT
102125	ROLL-ON STRIPING SULKY

Note: When ordering parts, you must use the part number as shown for each part, not the index number. Always give the model and serial number to your parts and service representative.

Note: Items sold in bulk such as seals and hoses are sold by the foot.

Using This Manual

This manual is part of a service package for the Hustler® mowers. Use of this manual in conjunction with other Hustler® mower and component manuals will provide the information necessary to service and maintain Hustler® mowers.

This Parts Manual provides a complete parts listing for the unit. Use this manual when ordering parts. Illustrations used were current at the time of printing, but subsequent production changes may cause your machine to vary slightly in detail. Excel Industries, Inc. reserves the right to redesign and change the machine as deemed necessary, without notification. If a change has been made to your machine which is not reflected in this parts manual, see your Hustler dealer for current information and parts.

The Service Manual is a service guide for use by Service Technicians. It provides the necessary information needed to perform normal maintenance requirements on these units.

The Operator's Manual provides fundamental operational information and operational safety that is needed when operating the mower.

The component manuals are furnished by the various manufacturers to be used for the troubleshooting and servicing of their products.

Hardware Description Codes & Abbreviations

The following codes are used throughout this parts manual. Refer to this list when ordering parts.

ABBREVIATION	DESCRIPTION	ABBREVIATION	DESCRIPTION
CB	CARRIAGE BOLT	MB	MACHINE BUSHING
CE	CLEVIS PIN	MS	MACHINE SCREW
CN	CLIP NUT	NT	NUT
CP	COTTER PIN	SC	SELF TAPPING CAP SCREW
CS	CAP SCREW	SH	SOCKET HEAD
CW	CUP WASHER	SB	SHOULDER BOLT
FDRW	FENDER WASHER	SS	SET SCREW
FW	FLAT WASHER	OD	OUTSIDE DIAMETER
HX	HEX HEAD	ID	INSIDE DIAMETER
LW	LOCK WASHER	WN	WELD NUT

Standard Torques

The following chart lists the standard torque values for the threaded fasteners found in this manual. Torque all cap screws, nuts and set screws to these values unless a different torque is shown in the Notes section next to the fastener.

SIZE	FT-LBS	N•M	SIZE	FT-LBS	N•M
.250	8.2	11.1	M3	1	1.3
.312	17	23	M4	2.2	3
.375	30	40	M5	4.5	6.1
.438	48	65	M6	7.7	10.4
.500	73	99	M8	18.5	25
.562	105	143	M10	37	50
.625	145	200	M12	64	87
.750	260	350	M14	80	108.5
.875	420	565	M16	160	215
1.00	625	850	M20	320	435
			M24	555	750

Section 2

36" Frame	2-2
48" Frame	2-4
54" Frame	2-6
36" Cover.....	2-8
48" & 54" Cover.....	2-10
Miscellaneous Decals—Models Ending in "US"	2-12

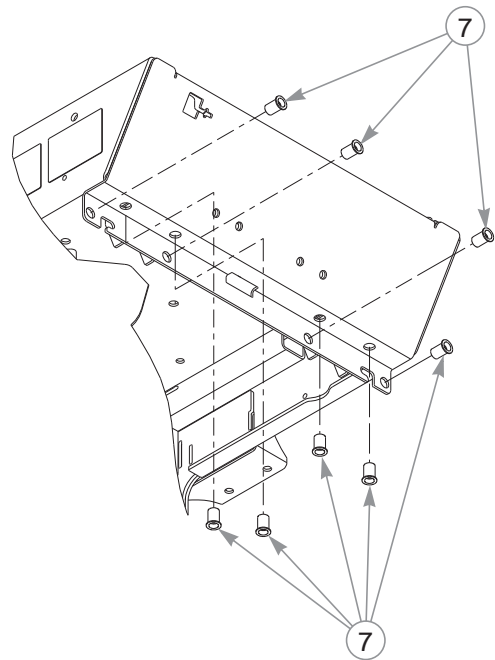
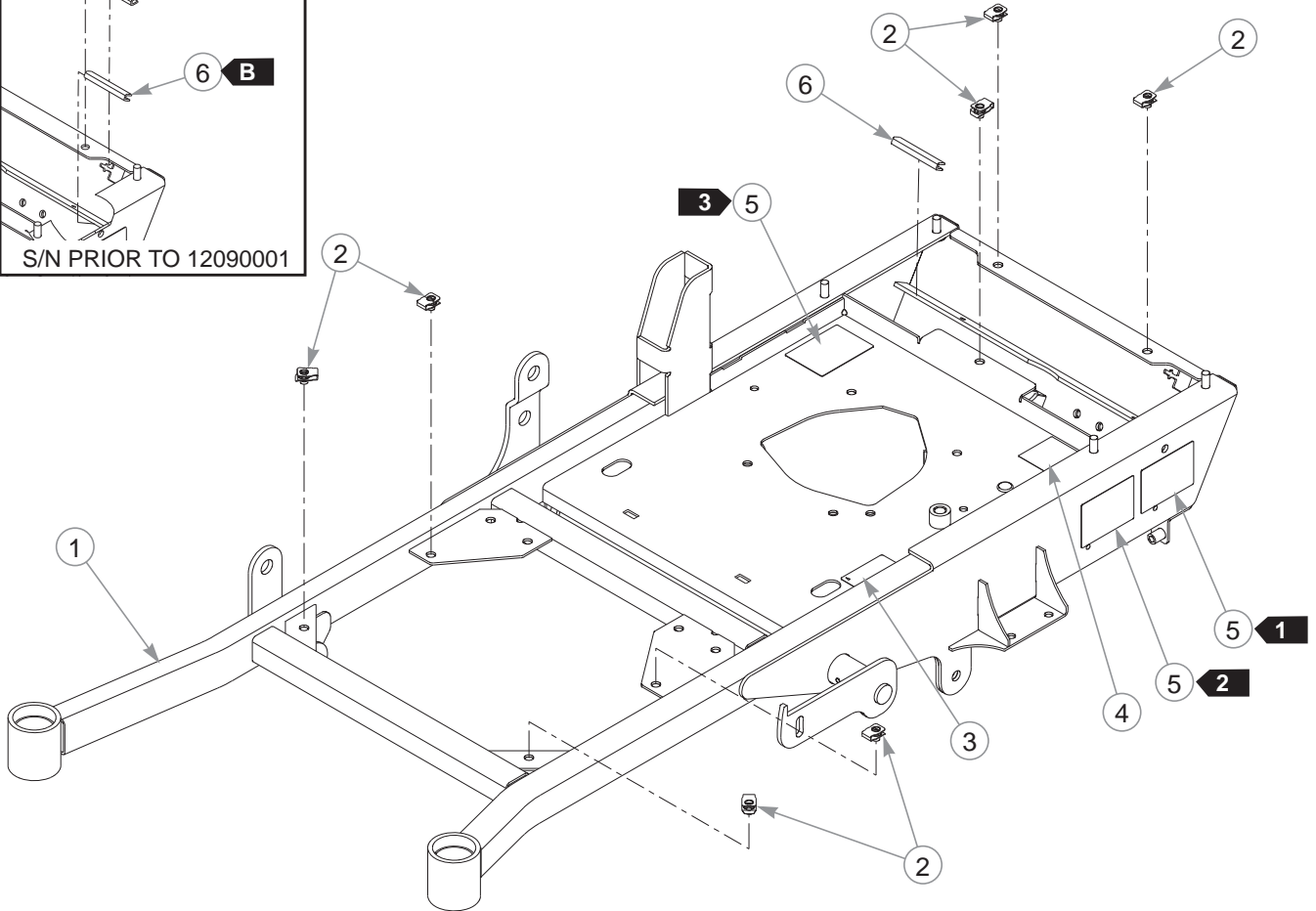
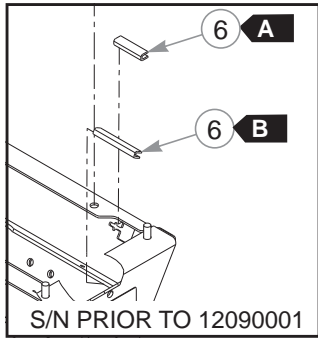

36" Frame



36" Frame

INDEX NO.	PART NO.	QTY.	DESCRIPTION
1	550226	1	36" MOWER FRAME (WITH DECALS & HARDWARE)
2	601069	7	CN .312-18 X .200 MAX THK
3	602041	1	HOT DECAL
4	797647	1	BELT DECAL
5	N/A	3	SERIAL NO. / SPEC DECAL
6	033001	3"	TRIM (S/N 12090001 & HIGHER)
	033001	8"	TRIM (S/N PRIOR TO 12090001)
7	808485	8	5/16-18 THREAD RIVET NUT

NOTES:

TRIM LENGTHS (S/N PRIOR TO 12090001)	
A 	2"
B 	6"

1. In the event the serial number decal becomes damaged or illegible, please contact your dealer to order a replacement.
2. Patent numbers decal.
3. EPA compliance decal.

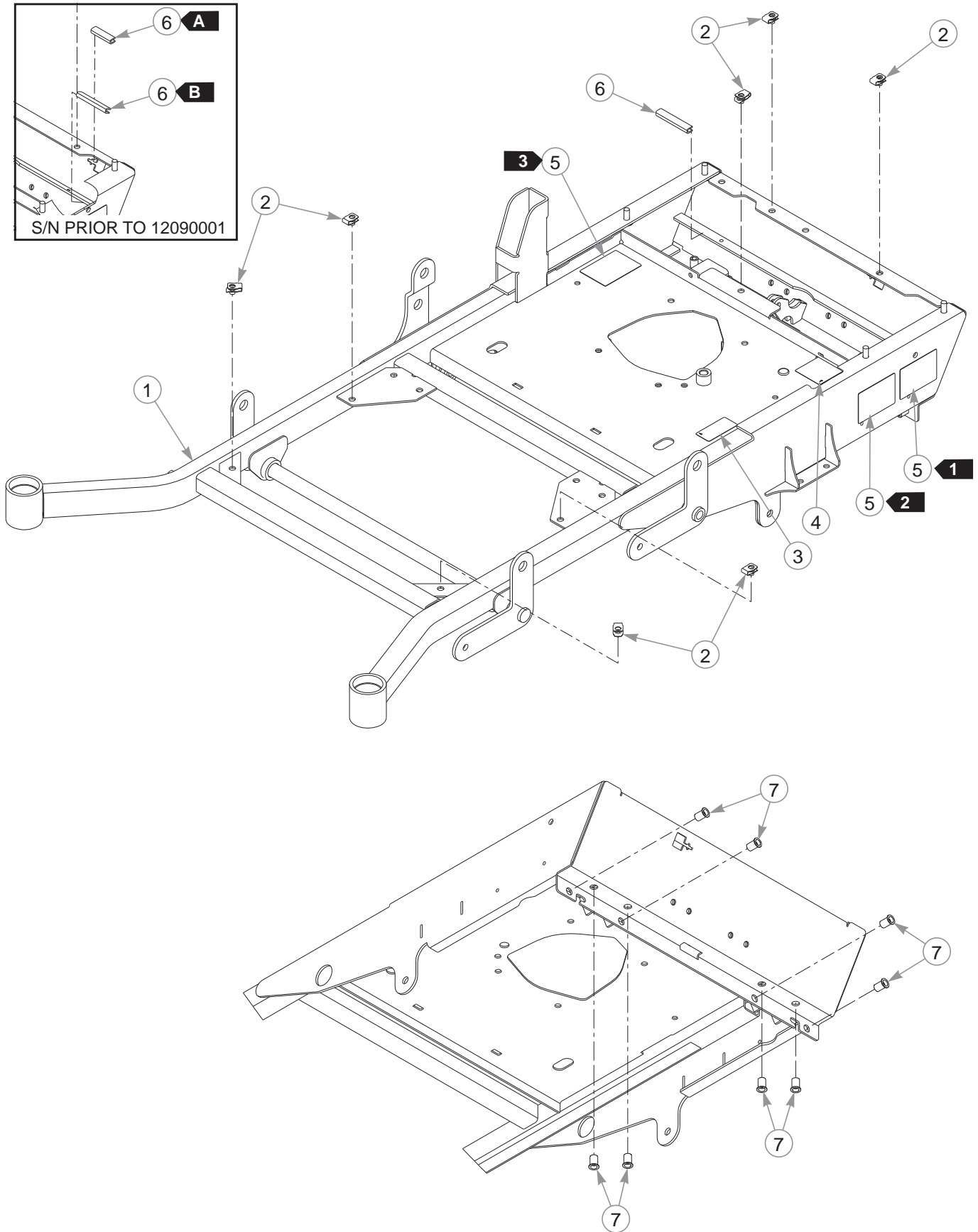

48" Frame



48" Frame

INDEX NO.	PART NO.	QTY.	DESCRIPTION
1	550227	1	48" MOWER FRAME (WITH DECALS & HARDWARE)
2	601069	7	CN .312-18 X .200 MAX THK
3	602041	1	HOT DECAL
4	797647	1	BELT ROUTING DECAL
5	N/A	3	SERIAL NO. / SPEC DECAL
6	033001	3"	TRIM (S/N 12090001 & HIGHER)
	033001	8"	TRIM (S/N PRIOR TO 12090001)
7	808485	8	5/16-18 THREAD RIVET NUT

NOTES:

TRIM LENGTHS (S/N PRIOR TO 12090001)	
	2"
	6"

1. In the event the serial number decal becomes damaged or illegible, please contact your dealer to order a replacement.
2. Patent numbers decal.
3. EPA compliance decal.

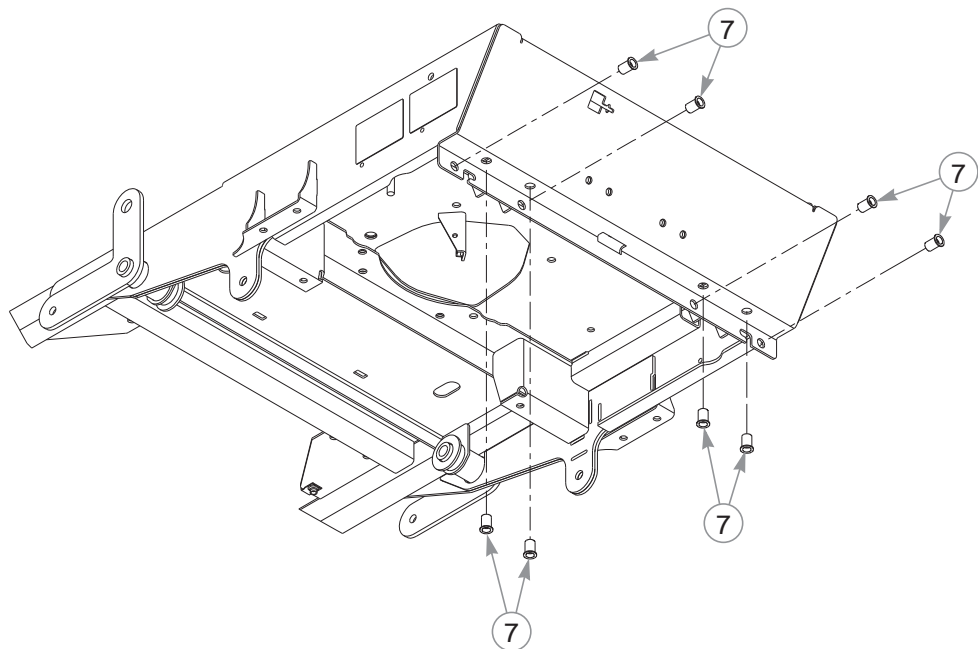
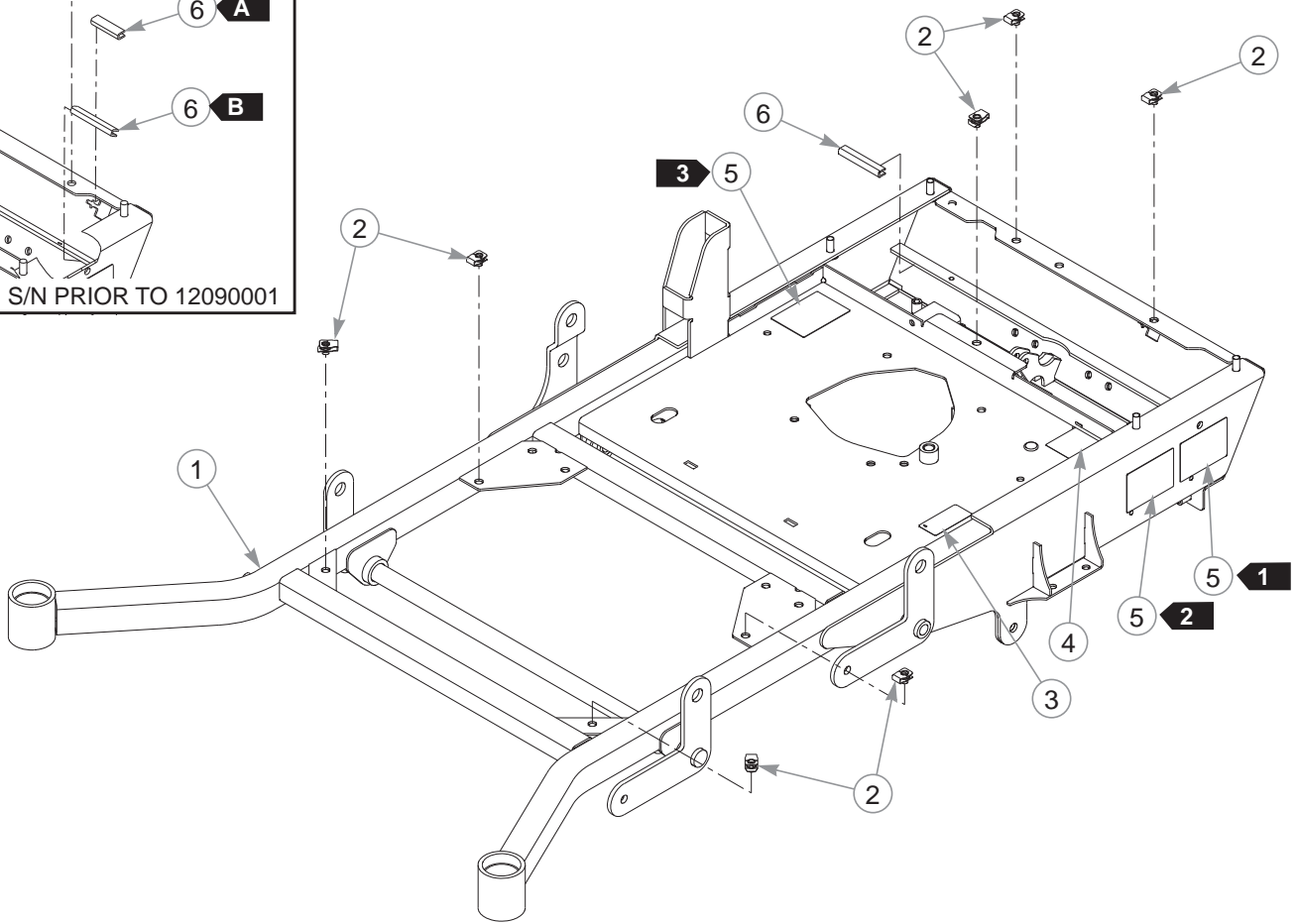
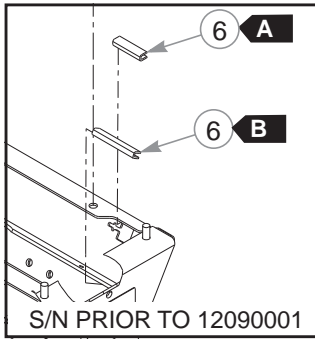

54" Frame



54" Frame

INDEX NO.	PART NO.	QTY.	DESCRIPTION
1	550228	1	54" MOWER FRAME (WITH DECALS & HARDWARE)
2	601069	7	CN .312-18 X .200 MAX THK
3	602041	1	HOT DECAL
4	797647	1	BELT ROUTING DECAL
5	N/A	3	SERIAL NO. / SPEC DECAL
6	033001	3"	TRIM (S/N 12090001 & HIGHER)
	033001	8"	TRIM (S/N PRIOR TO 12090001)
7	808485	8	5/16-18 THREAD RIVET NUT

NOTES:

TRIM LENGTHS (S/N PRIOR TO 12090001)	
A 	2"
B 	6"

1. In the event the serial number decal becomes damaged or illegible, please contact your dealer to order a replacement.
2. Patent numbers decal.
3. EPA compliance decal.

36" Cover

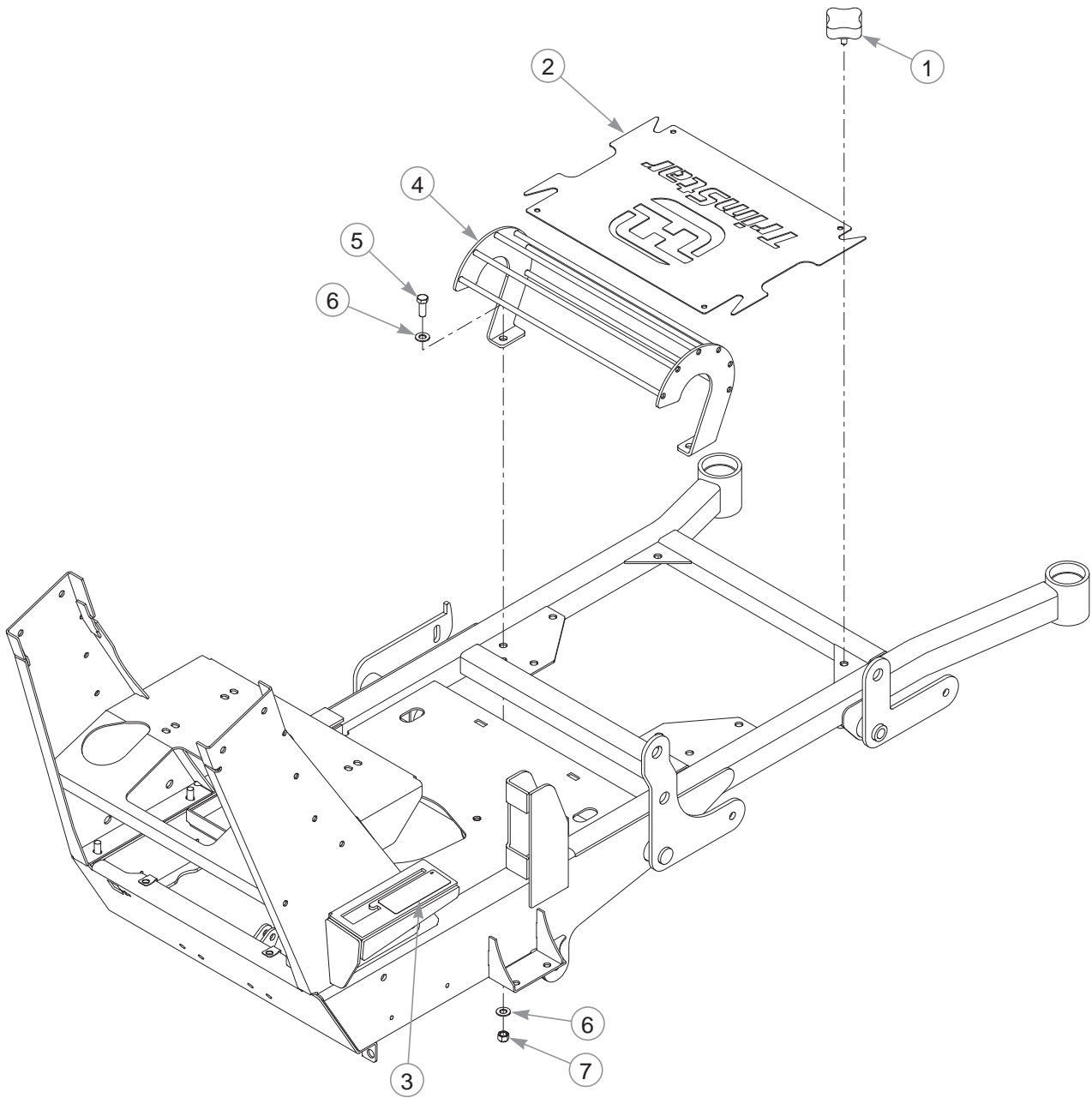

36" Cover

INDEX NO.	PART NO.	QTY.	DESCRIPTION
1	792002	4	KNOB 5/16-18 X 3/4"
2	114002	1	DECK COVER
3	602061	1	DECK HEIGHT DECAL
4	114509	1	SHIELD
5	036244	2	CS .375-16 X 1.00 HX G5
6	767954	4	FW .406 X .812 X .060 SAE
7	086660	2	NT .375-16 HXZY NL

NOTES:

48" & 54" Cover

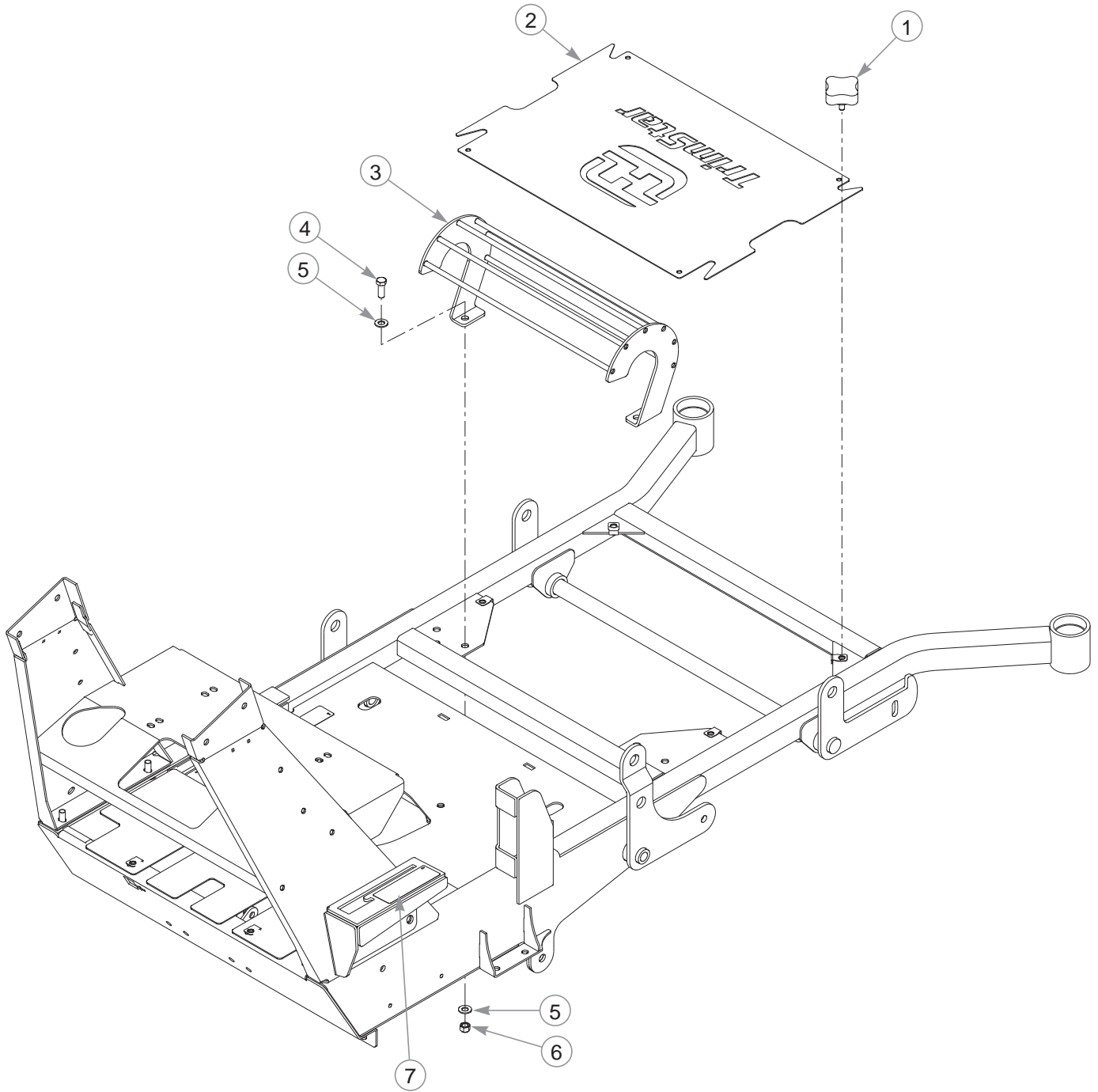

48" & 54" Cover

INDEX NO.	PART NO.	QTY.	DESCRIPTION
1	792002	4	KNOB 5/16-18 X 3/4"
2	114003	1	DECK COVER
3	114509	1	SHIELD
4	036244	2	CS .375-16 X 1.00 HX G5
5	767954	4	FW .406 X .812 X .060 SAE
6	086660	2	NT .375-16 HXZY NL
7	602061	1	DECK HEIGHT DECAL

NOTES:

Miscellaneous Decals—Models Ending in "US"

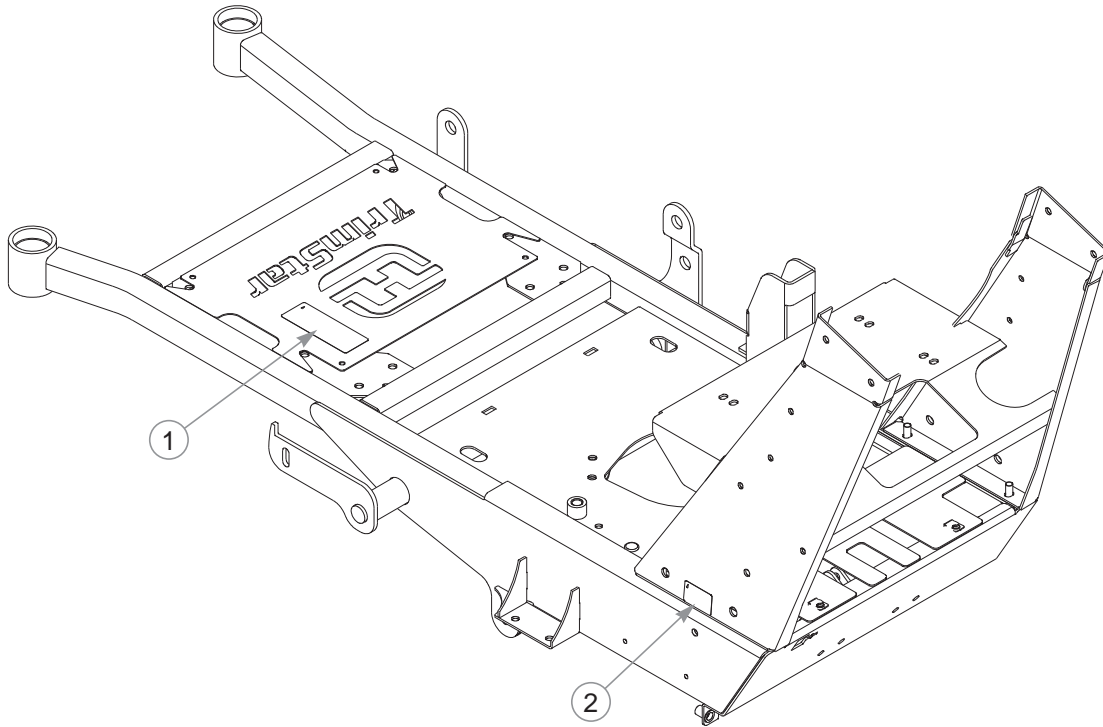

INDEX NO.	PART NO.	QTY.	DESCRIPTION
1	601908	1	SPARK ARRESTER DECAL
2	603363	1	ANSI COMPLIANCE DECAL

NOTES:

Section 3

36" Hydraulic System	3-2
36" Transmission Assembly	3-6
48" & 54" Hydraulic System—S/N 13014137 & Higher	3-12
48" & 54" Hydraulic System—S/N Prior to 13014137	3-16
48" & 54" Transmission Assembly.	3-20
Transmission Service Parts.	3-26
Handlebar	3-28
Throttle.	3-30
Instrument Panel	3-32
Instrument Panel, Electric Start	3-40
36" Brake—S/N 13015041 & Higher	3-48
36" Brake—S/N Prior to 13015041	3-50
48" & 54" Brake—S/N 13014137 & Higher	3-52
48" & 54" Brake—S/N Prior to 13014137	3-54

36" Hydraulic System

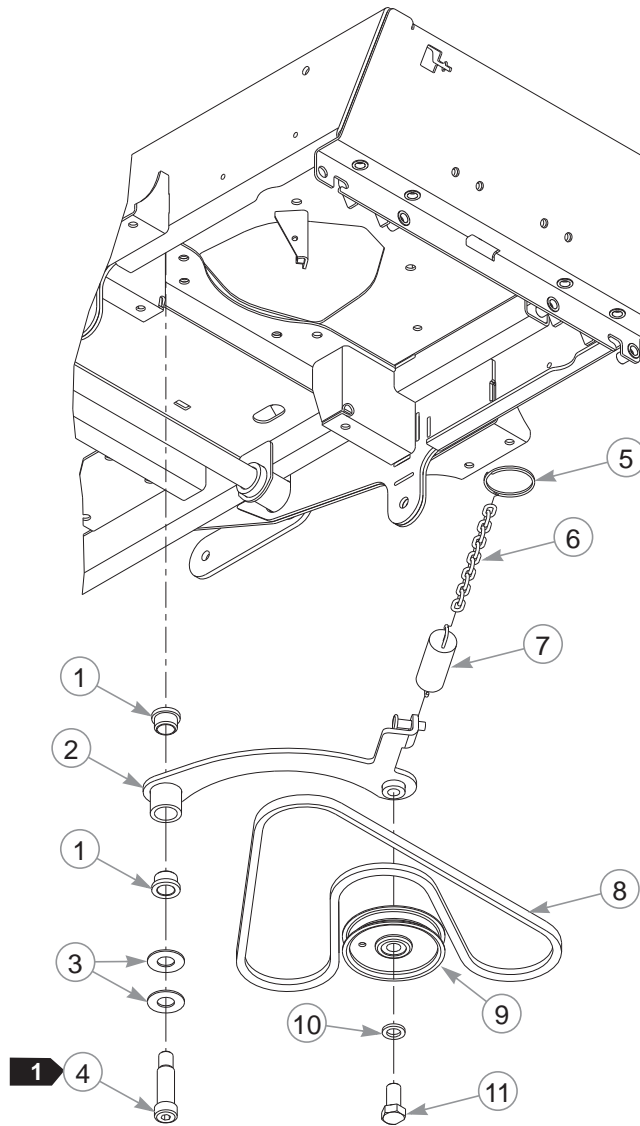

36" Hydraulic System

INDEX NO.	PART NO.	QTY.	DESCRIPTION
1	781153	2	BUSHING
2	110551	1	IDLER ARM
3	025296	2	FW .760 X 1.625 X .08
4	601084	1	SB .750 X 2.00 SH .625-11
5	778746	1	RING, 2" ID SPLIT
6	259812	1	CHAIN, 13 LINK
7	036384	1	SPRING 1/4 COIL PL 1.23
8	601838	1	BELT, A SEC 58.5" EL
9	786848	1	IDLER PULLEY
10	028118	1	FW .625 X 1.00 X .134
11	781872	1	CS .625-11 X 1.25 HX G5 Z

NOTES:

1. Torque to 100 ft-lbs.

36" Hydraulic System

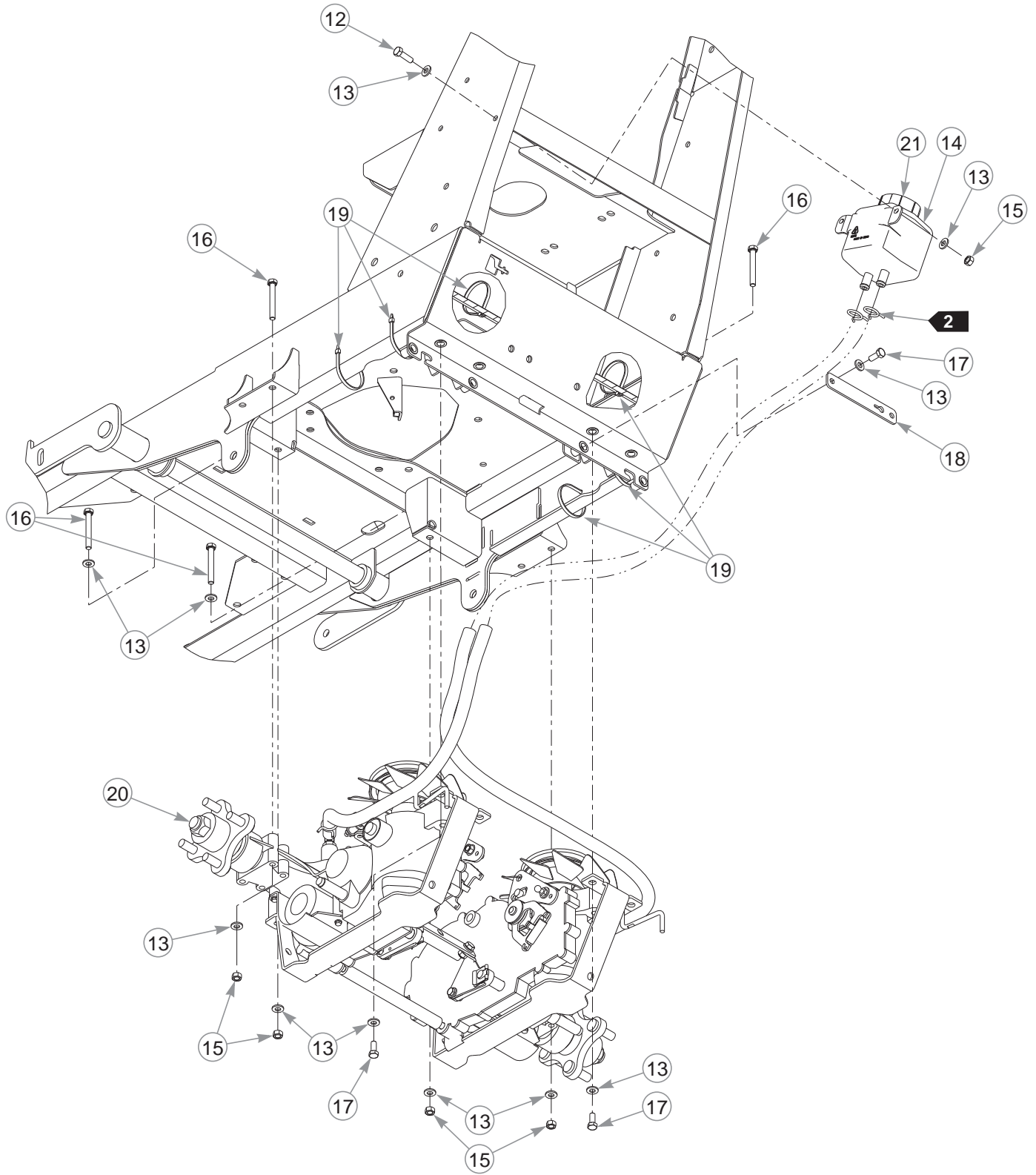

36" Hydraulic System

INDEX NO.	PART NO.	QTY.	DESCRIPTION
12	036236	2	CS .312-18 X 1.00 HX G5
13	768523	24	FW .343 X .687 X .051/.080H
14	601996	1	OVERFLOW TANK (WITH CAP)
15	034272	10	NT .312-18 HX G5 ZNYC
16	710087	8	CS .312-18 X 2.50 HX G5
17	034280	8	CS .312-18 X .75 HX G5
18	111157	2	TOW VALVE PLATE
19	000331	6	WIRE TIE
20	N/A	1	TRANSMISSION ASSEMBLY
21	600767	1	OVERFLOW TANK CAP

NOTES:

2. Part of the Transmission Assembly.

36" Transmission Assembly

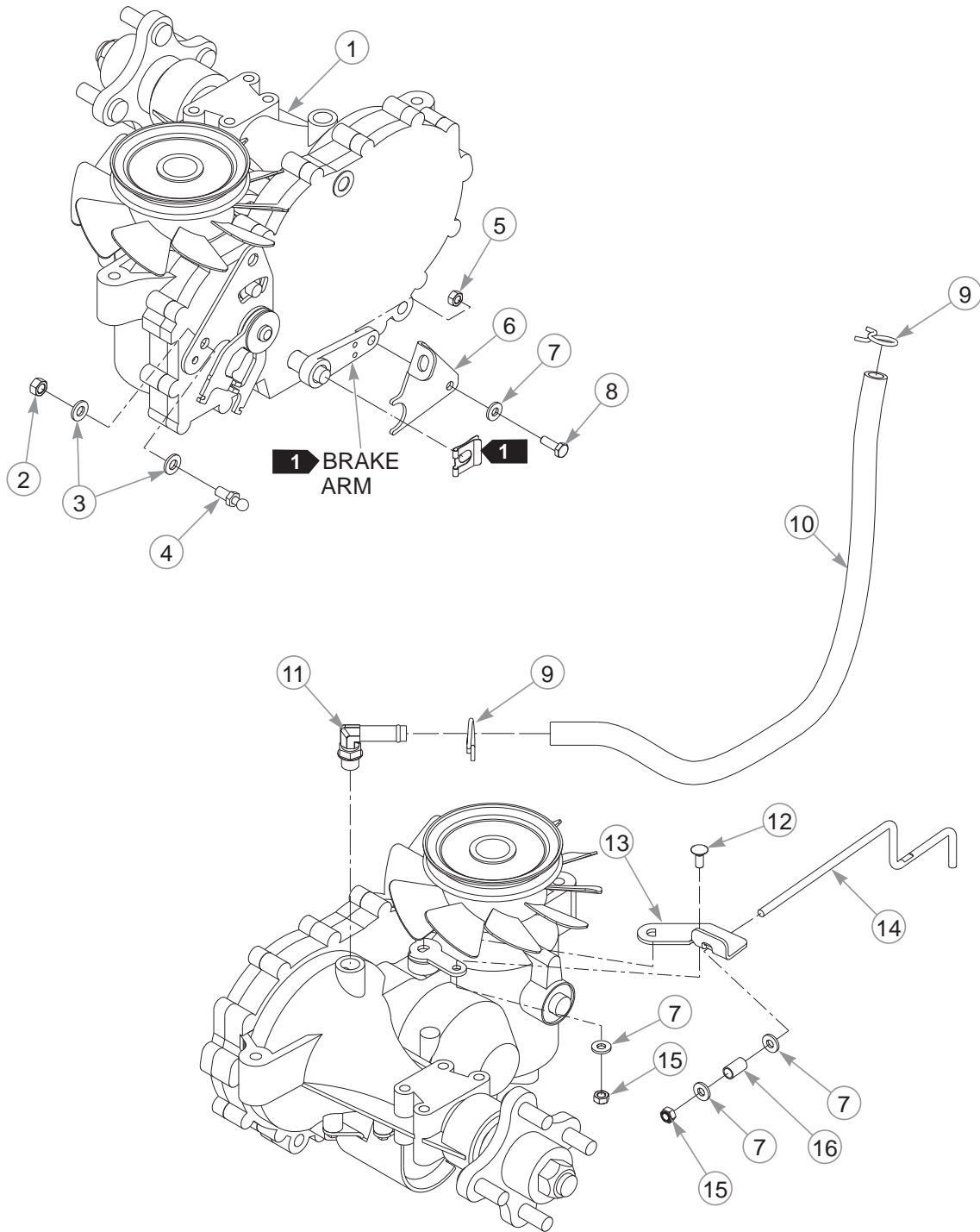

36" Transmission Assembly

INDEX NO.	PART NO.	QTY.	DESCRIPTION
1	601682	1	LS TRANSMISSION
2	034272	2	NT .312-18 HX G5
3	768523	8	FW .343 X .687 X .051/.080H
4	781922	2	BALL STUD
5	024927	2	NT .250-20 HX G5
6	109202	1	LS BRAKE SPRING LINK
7	768515	8	FW .281 X .625 X .066
8	055939	2	CS .250-20 X .75 HX G5
9	601001	4	SPRING CLAMP
10	605897	1	HOSE, 22"
11	601219	2	FITTING, 90 - 9/16 SAE
12	601503	2	CB .250-20 X .625 ZNYC
13	111616	1	LS TOW VALVE BRACKET
14	602228	2	TOW LINK ROD
15	068551	4	NT .250-20 HX ZY NL
16	041988	2	SPRING

NOTES:

1. Supplied with the transmission.

36" Transmission Assembly

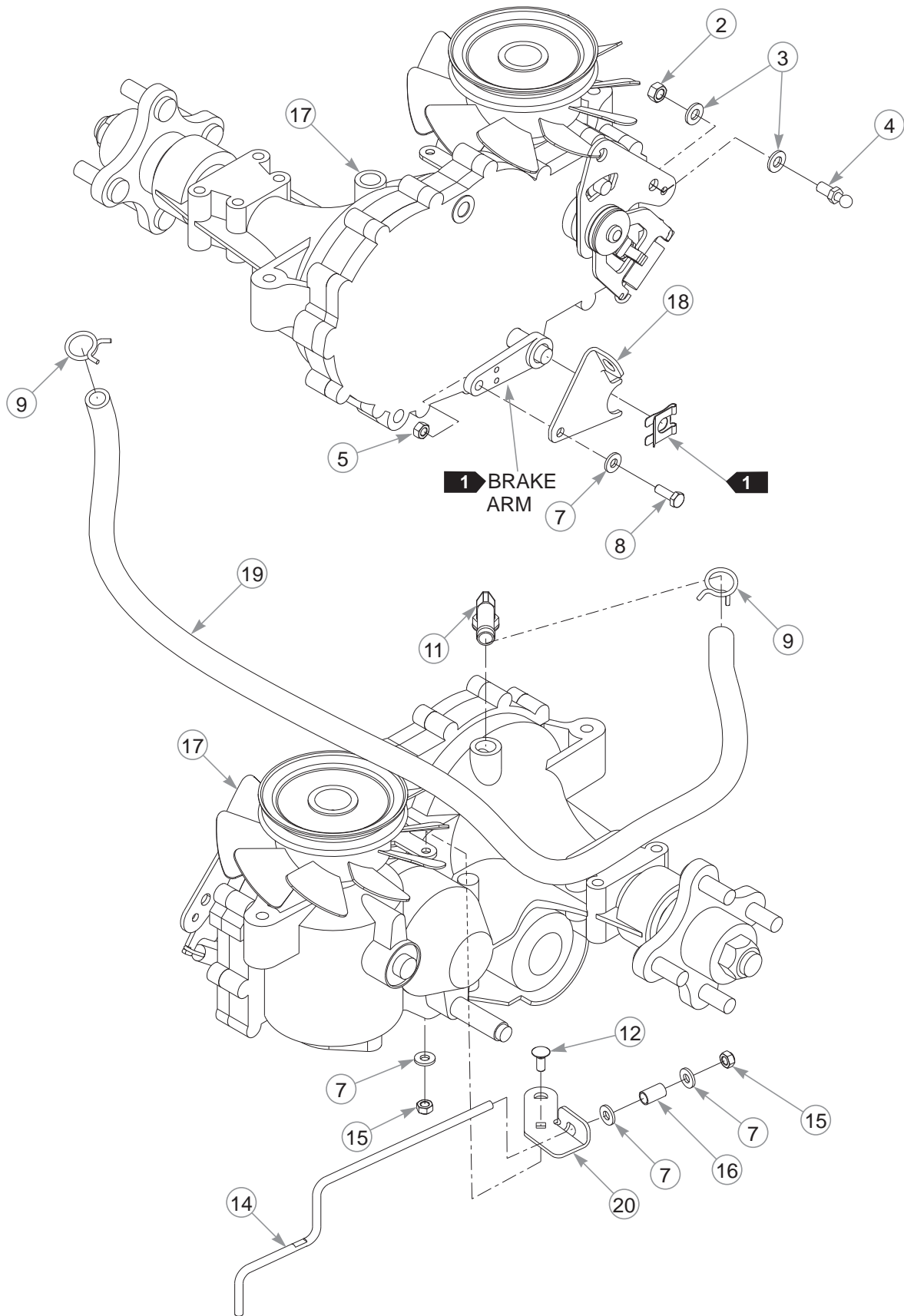

36" Transmission Assembly

INDEX NO.	PART NO.	QTY.	DESCRIPTION
17	601683	1	RS TRANSMISSION
18	109203	1	RS BRAKE SPRING LINK
19	605898	1	HOSE 37.5"
20	111617	1	RS TOW VALVE BRACKET

NOTES:

36" Transmission Assembly

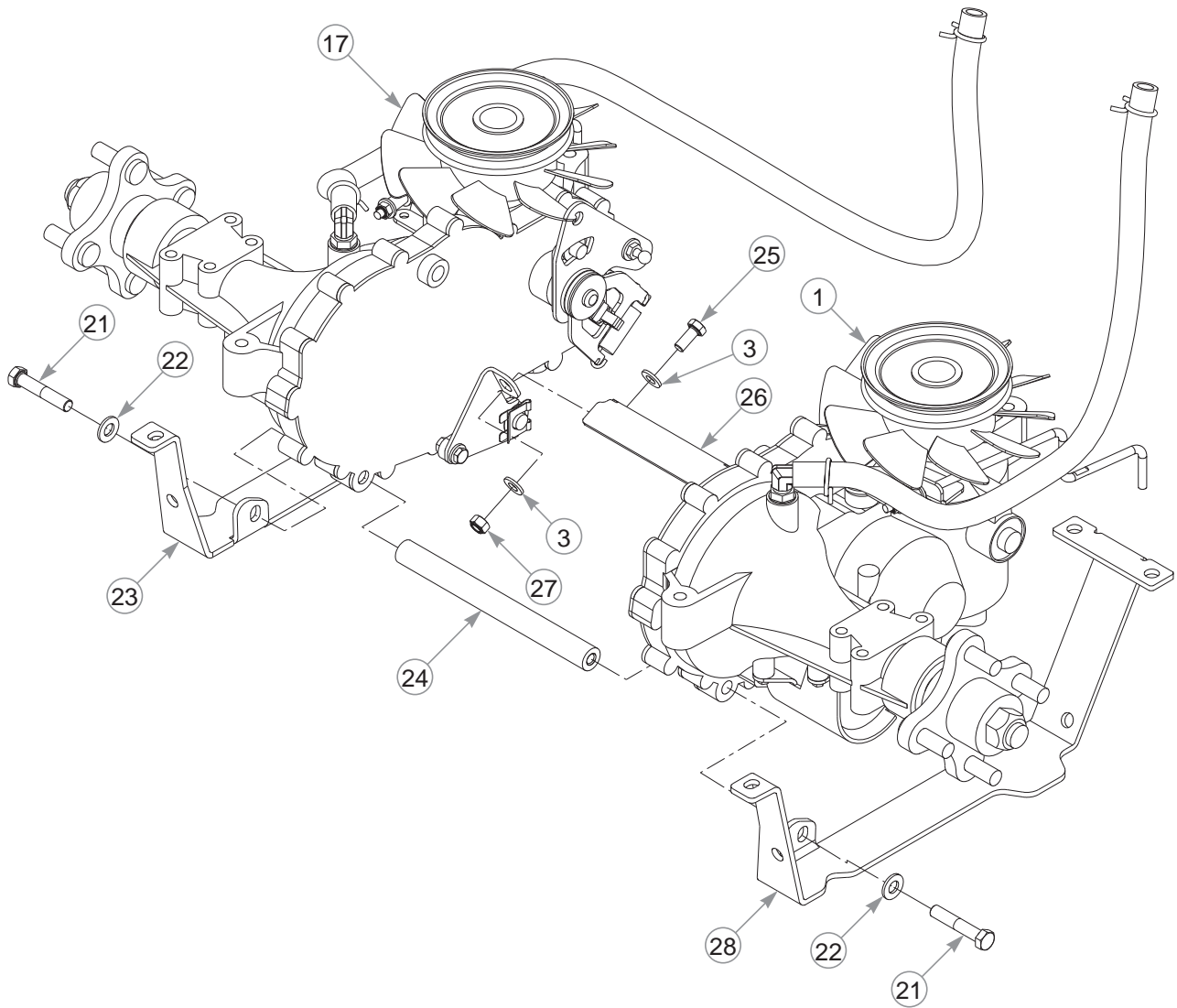

36" Transmission Assembly

INDEX NO.	PART NO.	QTY.	DESCRIPTION
21	016410	2	CS .375-16 X 2.00 HX G5
22	767954	2	FW .379 X .813 X .063
23	110731	1	RS CHARGE PUMP COVER
24	110537	1	SPACER TUBE
25	034280	2	CS .312-18 X .75 HX G5
26	110538	1	BRAKE PULL BRACKET
27	058776	2	NT .312-18 HX G5 ZY NL
28	110730	1	LS CHARGE PUMP COVER

NOTES:

48" & 54" Hydraulic System—S/N 13014137 & Higher

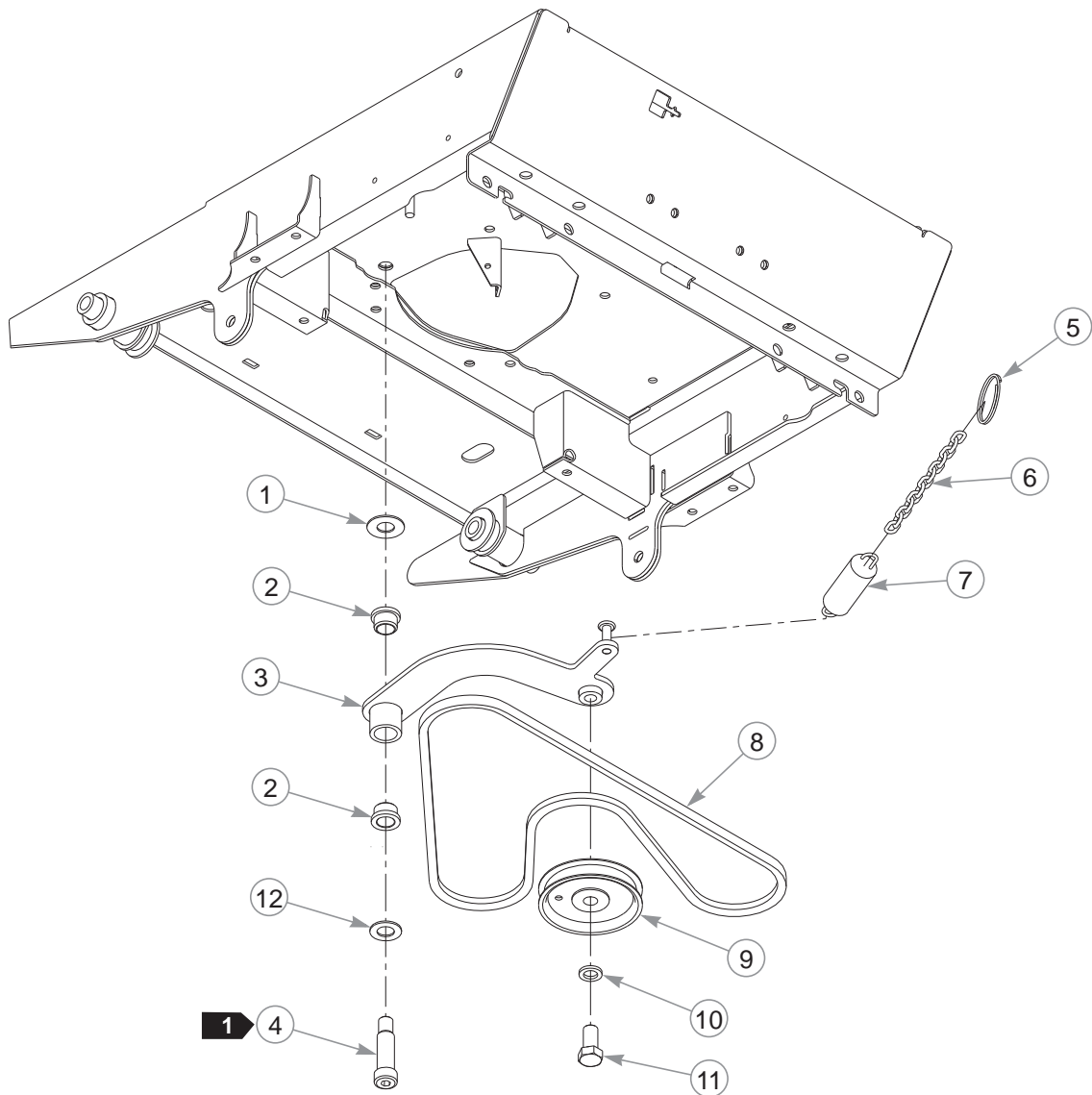

48" & 54" Hydraulic System—S/N 13014137 & Higher

INDEX NO.	PART NO.	QTY.	DESCRIPTION
1	025296	1	FW .760 X 1.625 X .08
2	781153	2	BUSHING
3	110739	1	PUMP IDLER ARM
4	601084	1	SB .750 X 2.00 SH .625-11
5	778746	1	RING, 2" ID SPLIT
6	259812	1	CHAIN, 13 LINK
7	036384	1	SPRING 1/4 COIL PL 1.23
8	793836	1	BELT, A 63" EL
9	786848	1	IDLER PULLEY
10	028118	1	FW .625 X 1.00 X .134
11	781872	1	CS .625-11 X 1.25 HX G5 Z
12	604514	1	FW .760 X 1.38 X .080

NOTES:

1. Torque to 100 ft-lbs.

48" & 54" Hydraulic System—S/N 13014137 & Higher

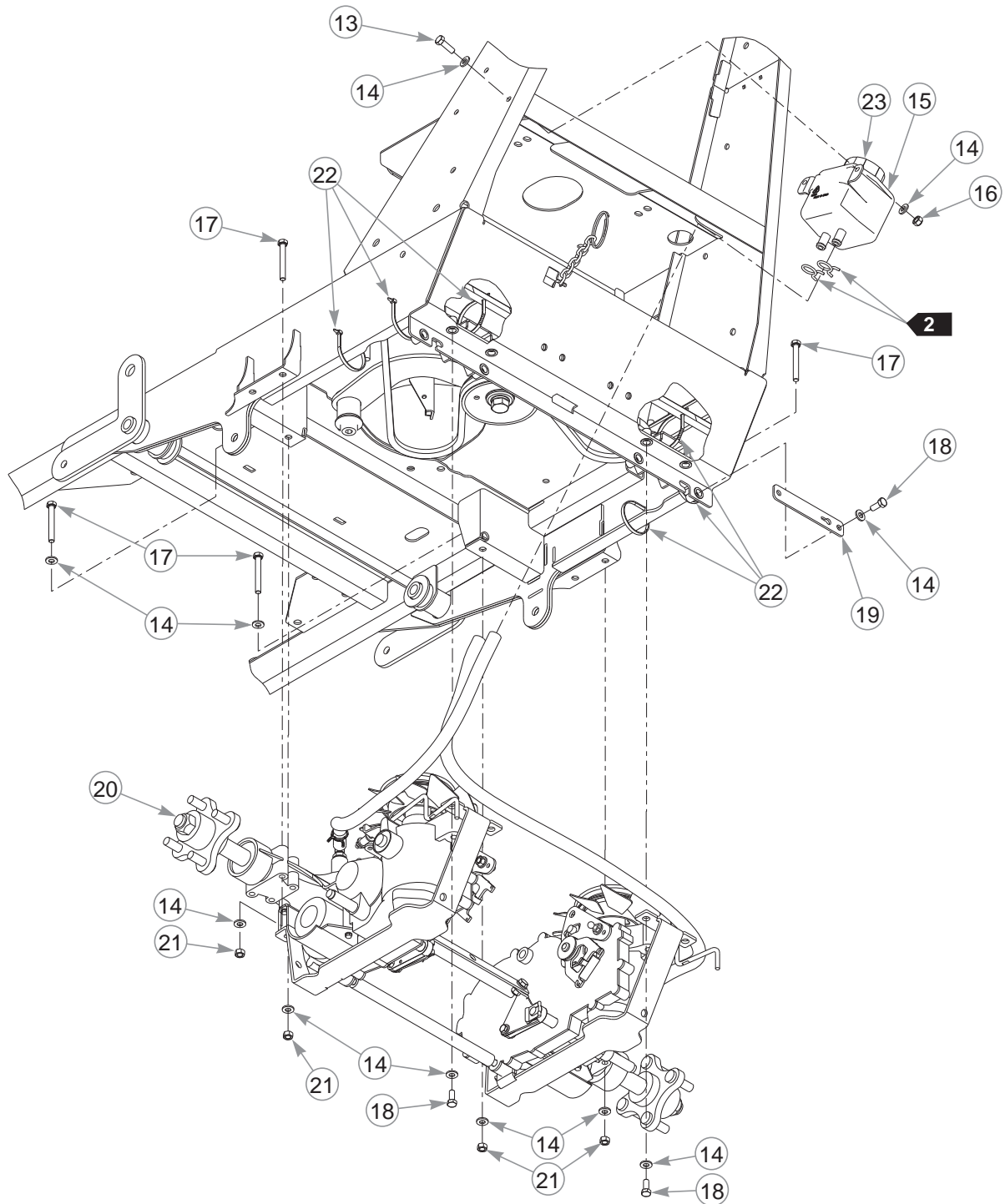

48" & 54" Hydraulic System—S/N 13014137 & Higher

INDEX NO.	PART NO.	QTY.	DESCRIPTION
13	036236	2	CS .312-18 X 1.00 HX G5
14	768523	24	FW .343 X .687 X .051/.080H
15	601996	1	OVERFLOW TANK (WITH CAP)
16	058776	2	NT .312-18 HX G5 ZY NL
17	710087	8	CS .312-18 X 2.50 HX G5
18	034280	8	CS .312-18 X .75 HX G5
19	111157	2	TOW VALVE PLATE
20	N/A	1	TRANSMISSION ASSEMBLY
21	034272	8	NT .312-18 HX G5
22	000331	6	WIRE TIE
23	600767	1	OVERFLOW TANK CAP

NOTES:

2. Part of the Transmission Assembly.

48" & 54" Hydraulic System—S/N Prior to 13014137

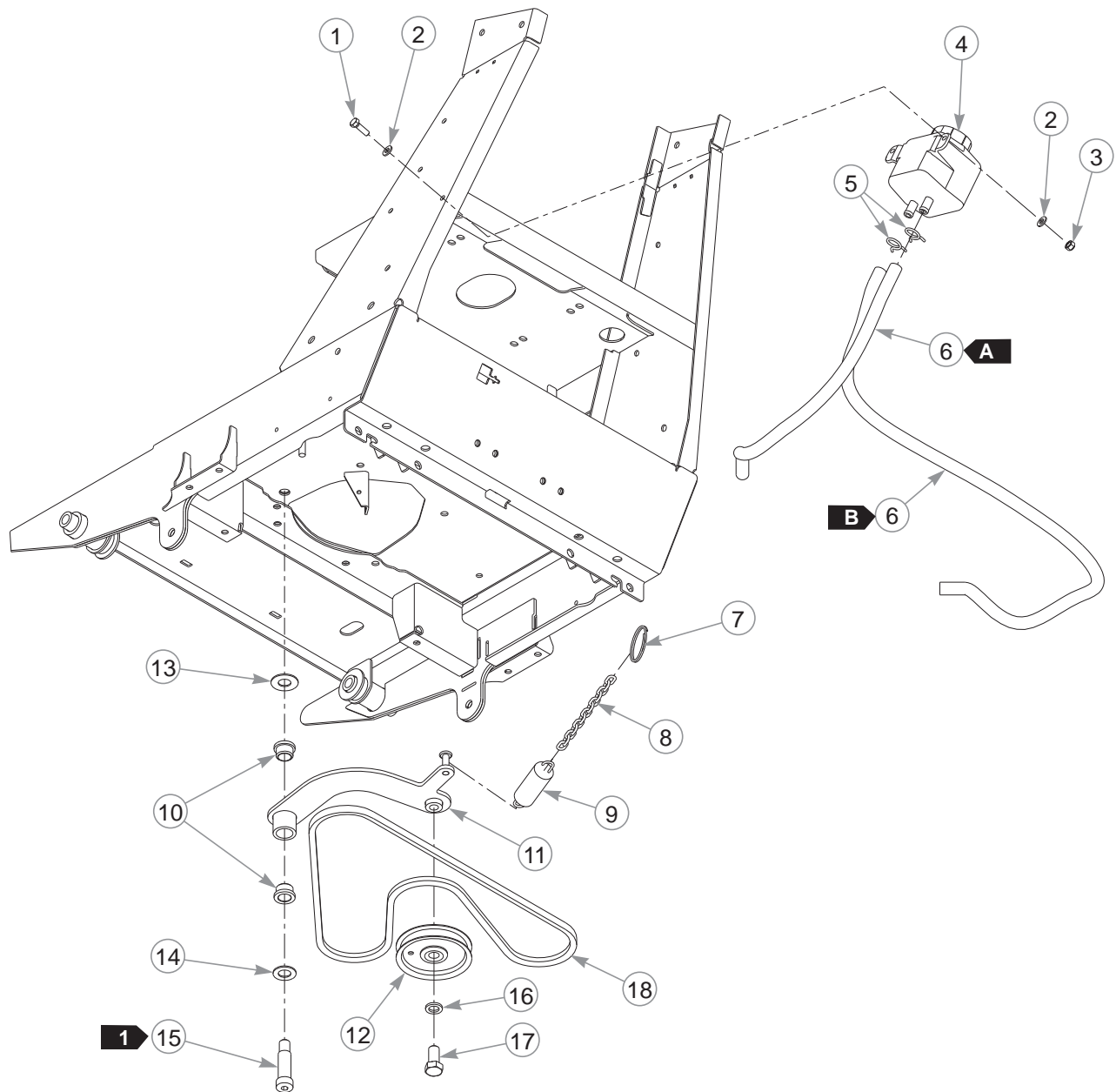

48" & 54" Hydraulic System—S/N Prior to 13014137

INDEX NO.	PART NO.	QTY.	DESCRIPTION
1	036236	2	CS .312-18 X 1.00 HX G5
2	768523	28	FW .343 X .687 X .051/.080H
3	058776	2	NT .312-18 HX G5 ZY NL
4	601996	1	OVERFLOW TANK (WITH CAP)
	600767	1	OVERFLOW TANK CAP
5	601001	4	SPRING CLAMP
6	787713	66"	HOSE, .50" LOW PRESSURE
7	778746	1	RING, 2" ID SPLIT
8	259812	1	CHAIN, 13 LINK
9	036384	1	SPRING 1/4 COIL PL 1.23
10	781153	2	BUSHING
11	110739	1	PUMP IDLER ARM
12	786848	1	IDLER PULLEY
13	025296	2	FW .760 X 1.625 X .08
14	604514	1	FW .760 X 1.38 X .080
15	601084	1	SB .750 X 2.00 SH .625-11
16	028118	1	FW .625 X 1.00 X .134
17	781872	1	CS .625-11 X 1.25 HX G5 Z
18	793836	1	BELT, A 63" EL

NOTES:

HYDRAULIC LINE LENGTHS		
A	23"	RESERVOIR TO LEFT SIDE TRANSMISSION
B	43"	RESERVOIR TO RIGHT SIDE TRANSMISSION

1. Torque to 100 ft-lbs.

48" & 54" Hydraulic System—S/N Prior to 13014137

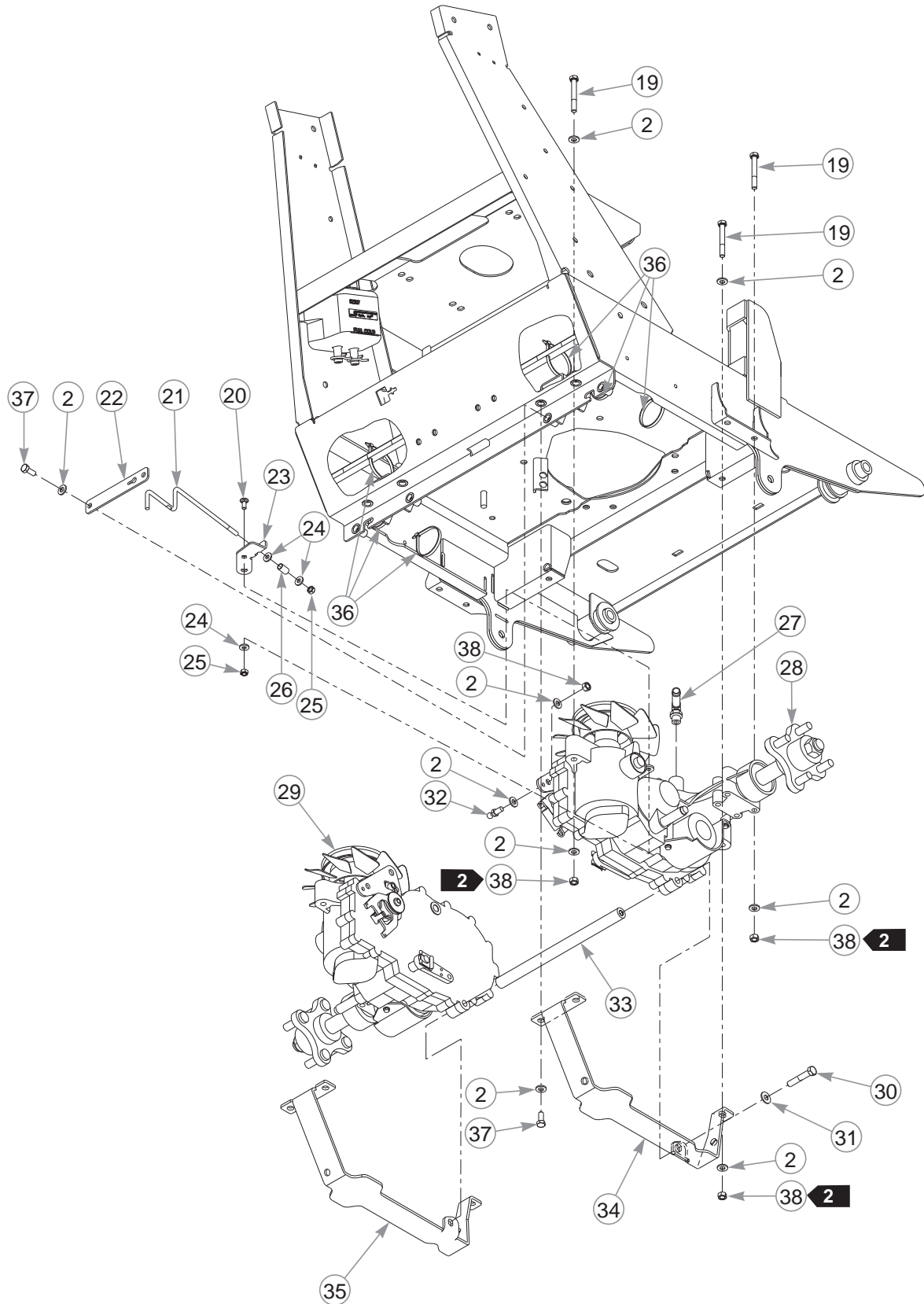

48" & 54" Hydraulic System—S/N Prior to 13014137

INDEX NO.	PART NO.	QTY.	DESCRIPTION
19	710087	8	CS .312-18 X 2.50 HX G5
20	601503	2	CB .250-20 X .625 ZNYC
21	602228	2	TOW LINK ROD
22	111157	2	TOW VALVE PLATE
23	111616	1	LS TOW VALVE BRACKET
	111617	1	RS TOW VALVE BRACKET (NOT SHOWN)
24	768515	6	FW .281 X .625 X .066
25	068551	4	NT .250-20 HX ZY NL
26	041988	2	SPRING
27	601219	2	FITTING, 90 - 9/16 SAE
28	601730	1	RS TRANSMISSION
29	601729	1	LS TRANSMISSION
30	016410	2	CS .375-16 X 2.00 HX G5
31	767954	2	FW .379 X .813 X .063
32	781922	2	BALL STUD
33	600987	1	SPACER TUBE
34	110731	1	RS CHARGE PUMP COVER
35	110730	1	LS CHARGE PUMP COVER
36	000331	6	WIRE TIE
37	034280	8	CS .312-18 X .75 HX G5
38	034272	10	NT .312-18 HX G5

NOTES:

2. Torque to 17 ft-lbs.

48" & 54" Transmission Assembly

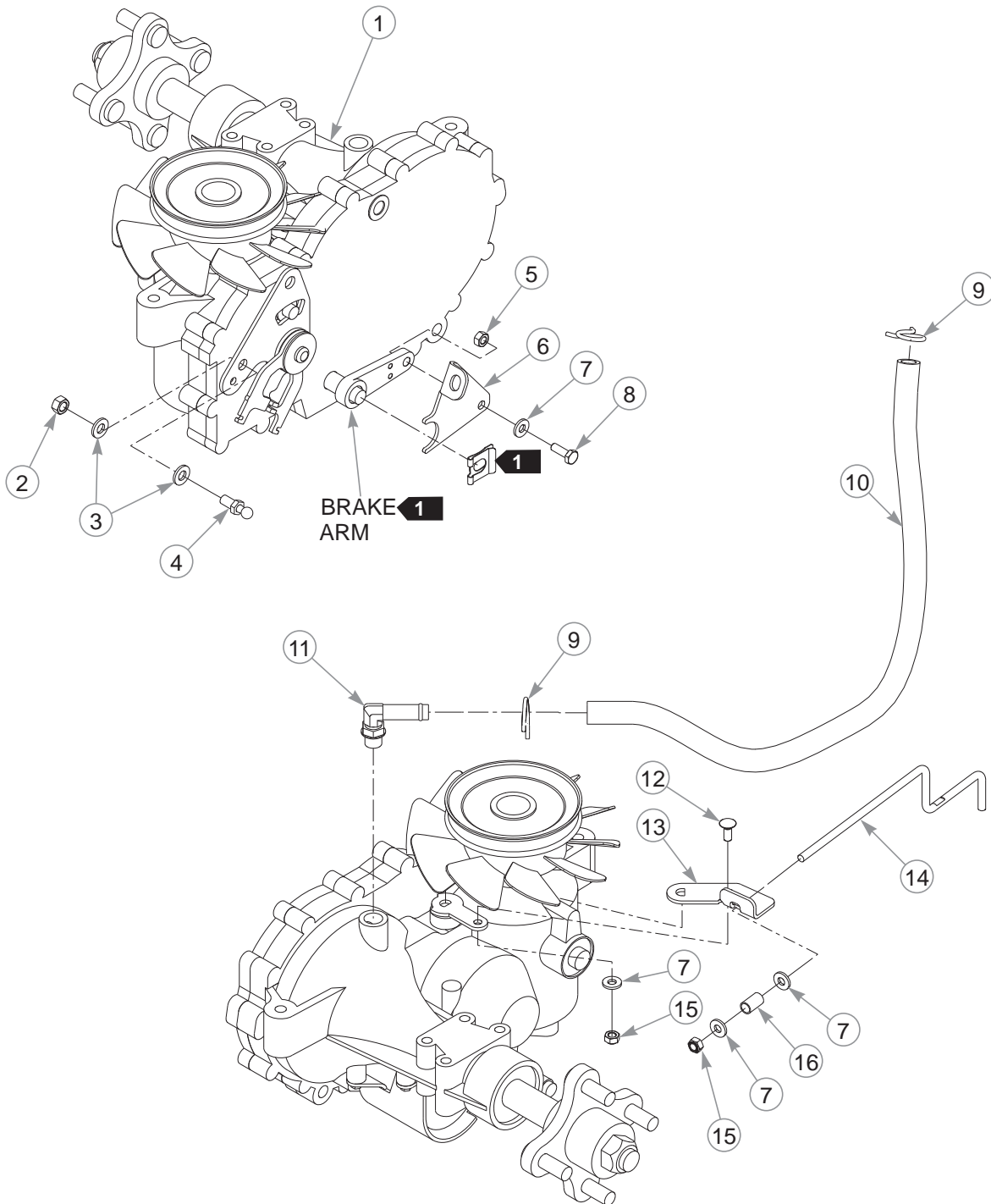

48" & 54" Transmission Assembly

INDEX NO.	PART NO.	QTY.	DESCRIPTION
1	601729	1	LS TRANSMISSION
2	034272	2	NT .312-18 HX G5
3	768523	8	FW .343 X .687 X .051/.080H
4	781922	2	BALL STUD
5	024927	2	NT .250-20 HX G5
6	109202	1	LS BRAKE SPRING LINK
7	768515	8	FW .281 X .625 X .066
8	055939	2	CS .250-20 X .75 HX G5
9	601001	4	SPRING CLAMP
10	605899	1	HOSE, 23"
11	601219	2	FITTING, 90 - 9/16 SAE
12	601503	2	CB .250-20 X .625 ZNYC
13	111616	1	LS TOW VALVE BRACKET
14	602228	2	TOW LINK ROD
15	068551	4	NT .250-20 HX ZY NL
16	041988	2	SPRING

NOTES:

1. Supplied with the transmission.

48" & 54" Transmission Assembly

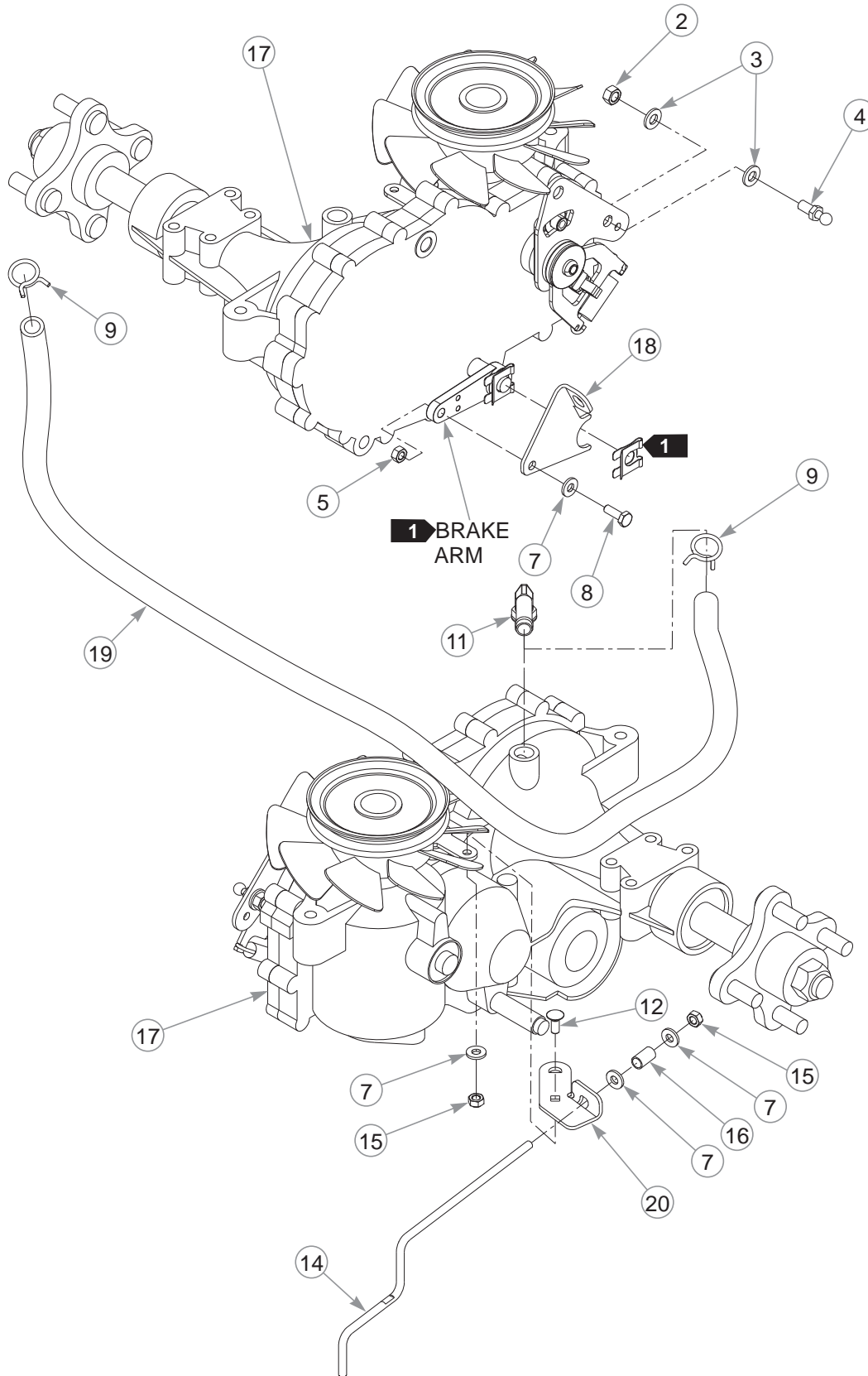

48" & 54" Transmission Assembly

INDEX NO.	PART NO.	QTY.	DESCRIPTION
17	601730	1	RS TRANSMISSION
18	109203	1	RS BRAKE SPRING LINK
19	605900	1	HOSE, 43"
20	111617	1	RS TOW VALVE BRACKET

NOTES:

48" & 54" Transmission Assembly

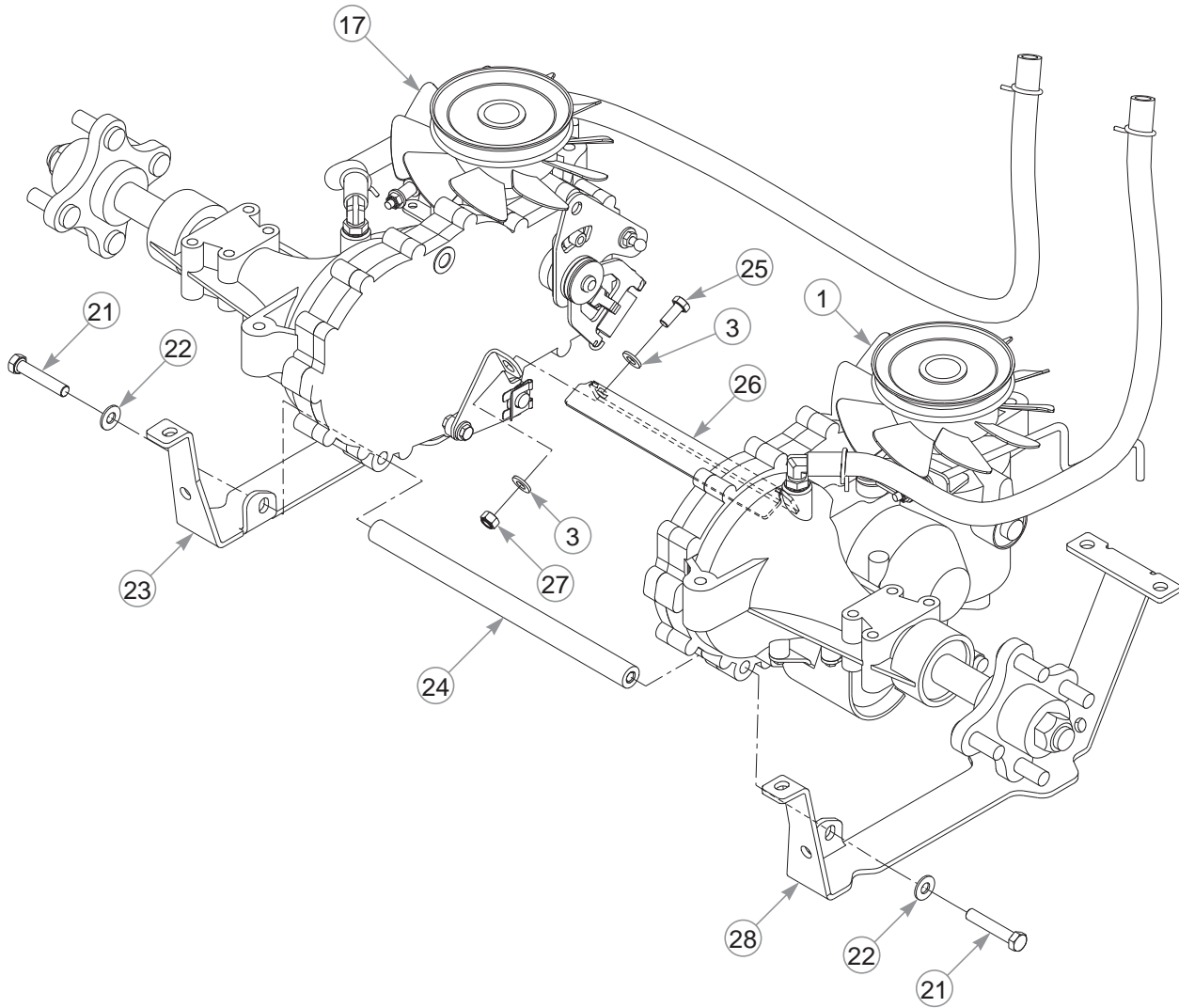

48" & 54" Transmission Assembly

INDEX NO.	PART NO.	QTY.	DESCRIPTION
21	016410	2	CS .375-16 X 2.00 HX G5
22	767954	2	FW .379 X .813 X .063
23	110731	1	RS CHARGE PUMP COVER
24	600987	1	SPACER TUBE
25	034280	2	CS .312-18 X .75 HX G5
26	110601	1	BRAKE PULL BRACKET
27	058776	2	NT .312-18 HX G5 ZY NL
28	110730	1	LS CHARGE PUMP COVER

NOTES:

Transmission Service Parts

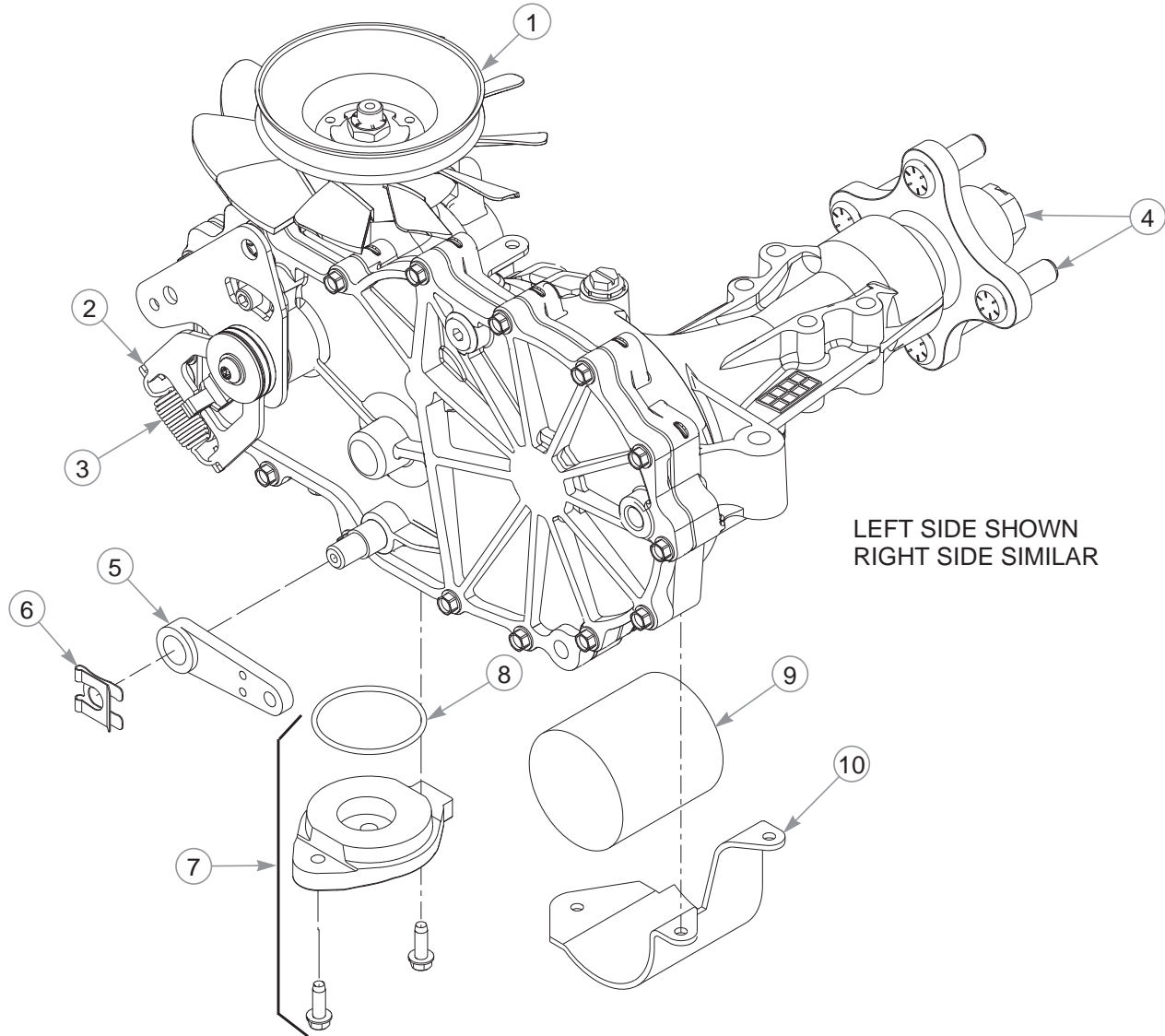

INDEX NO.	PART NO.	QTY.	DESCRIPTION
1	602094	1	FAN/PULLEY KIT
2	604901	1	HG RTN CW (LEFT SIDE TRANSMISSION)
	604902	1	HG RTN CCW (RIGHT SIDE TRANSMISSION)
3	604903	1	HG RTN SPRING
4	601433	1	4 BOLT HUB KIT (INCLUDES NUT)
5	601221	1	BRAKE ARM
6	600972	1	RETAINING CLIP
7	603572	1	CHARGE COVER KIT
8	603223	1	O-RING
9	600976	1	OIL FILTER
10	600975	1	LS FILTER GUARD
	600974	1	RS FILTER GUARD (NOT SHOWN)
11	602208	1	EXTENSION SPRING (NOT SHOWN)

This page intentionally left blank.

Handlebar

INDEX NO.	PART NO.	QTY.	DESCRIPTION
1	771139	2	GRIP, .875 X 4.562 BLK
2	773556	2	STEERING BEARING
3	110766	1	STEERING BAR
4	785766	2	STEERING ROD ADJUSTER
5	041152	2	NT .312-24 HX ZNYC
6	768523	8	FW .343 X .687 X .051/.080H
7	601839	2	PIVOT SPACER BUSHING
8	769299	6	SC #10 X .75 PHILLIPS T
9	550071	1	STEERING COVER (WITH DECAL)
10	779157	2	CB .312-18 X 1.75
11	058776	2	NT .312-18 HX G5 ZY NL
12	077842	4	MS # 6-32 X 1.00 RD SL
13	341826	2	OPC ARM
14	342378	2	SWITCH SPACER
15	779165	4	RP .078 X .50 LONG ZN
16	039693	2	WN #6-32 X 1.00 TP 1116
17	601972	1	WIRE HARNESS, OPC
18	771030	1	STEERING DECAL

NOTES:

Throttle

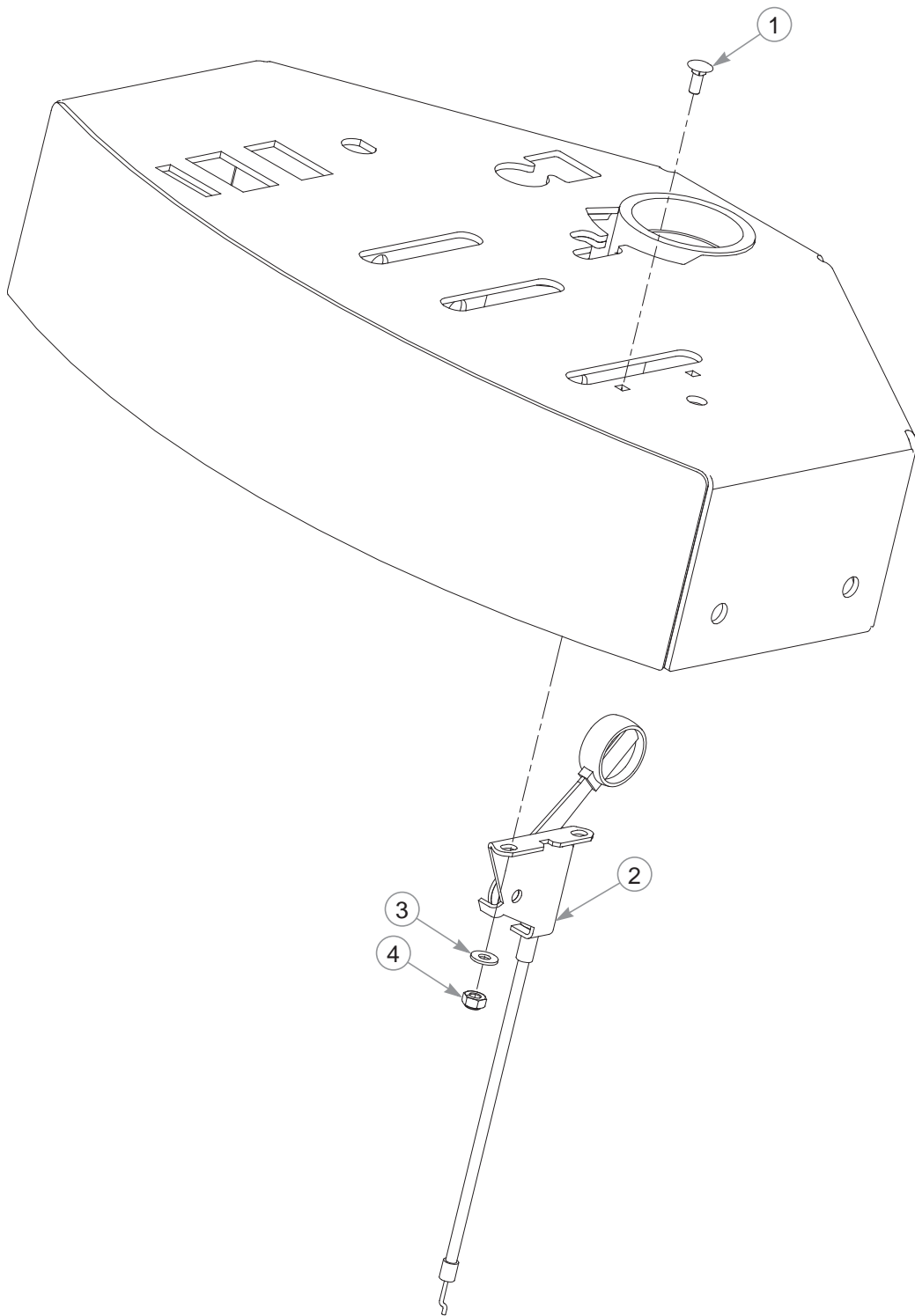

Throttle

INDEX NO.	PART NO.	QTY.	DESCRIPTION
1	601098	2	CB 10-24 X .500 ZYNC
2	778365	1	THROTTLE CABLE
3	704932	2	FW .219 X .500 X .048 ZNYC
4	059832	2	NT #10-24 HX NL ZN

NOTES:

Instrument Panel

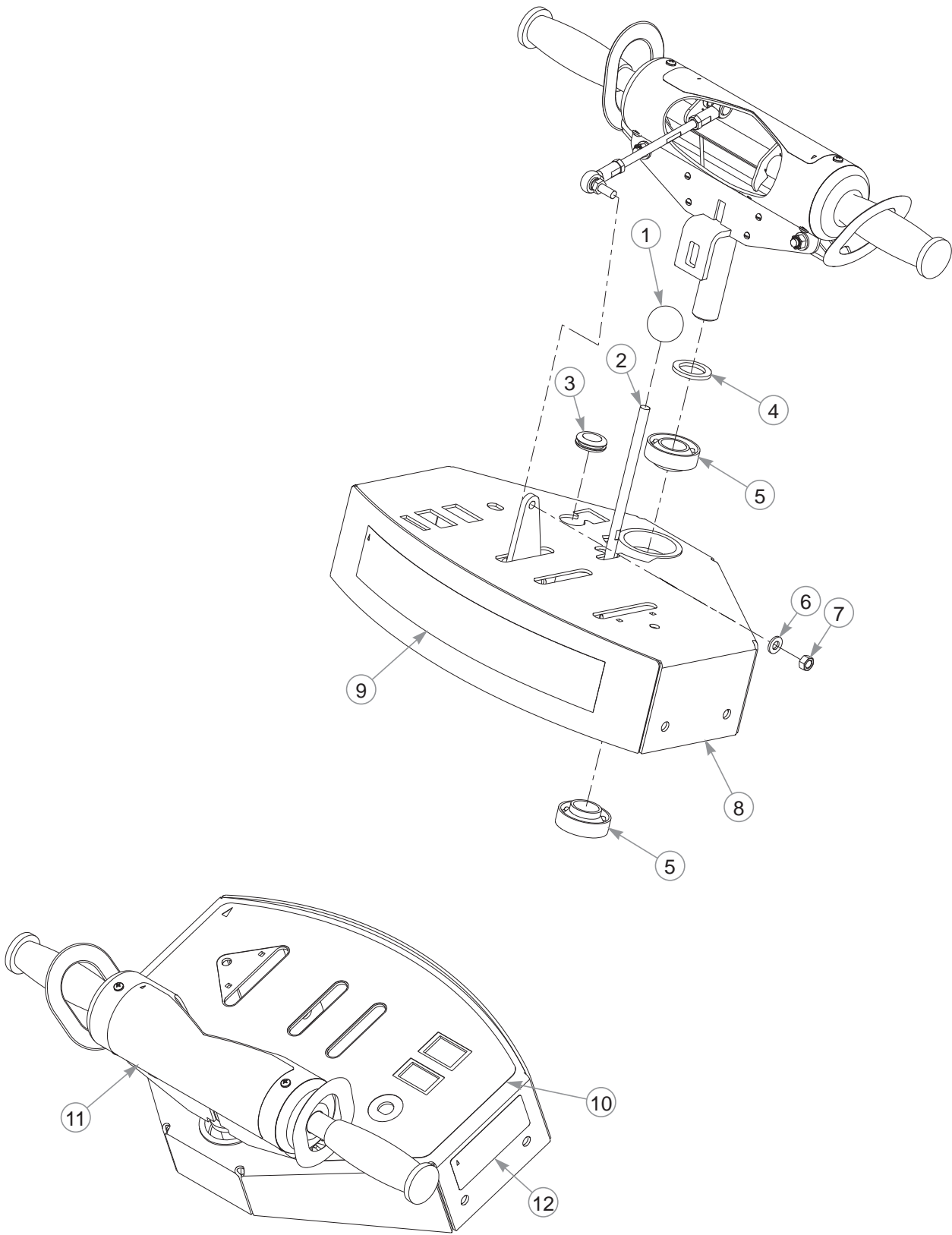

Instrument Panel

INDEX NO.	PART NO.	QTY.	DESCRIPTION
1	043299	1	KNOB
2	110645	1	NEUTRAL LOCK HANDLE ROD
3	047456	1	GM .750 X .188 X 1.00 X .12
4	045765	3	FW 1.030 X 1.50 X .134
5	784223	2	BEARING
6	768523	10	FW .343 X .687 X .051/.080H
7	041152	2	NT .312-24 HX ZNYC
8	550072	1	CONSOLE (WITH DECALS)
9	605669	1	ID DECAL
10	601934	1	INSTRUMENT PANEL DECAL
11	771030	1	STEERING DECAL
12	601967	1	ENGINE COMPARTMENT DECAL

NOTES:

Instrument Panel

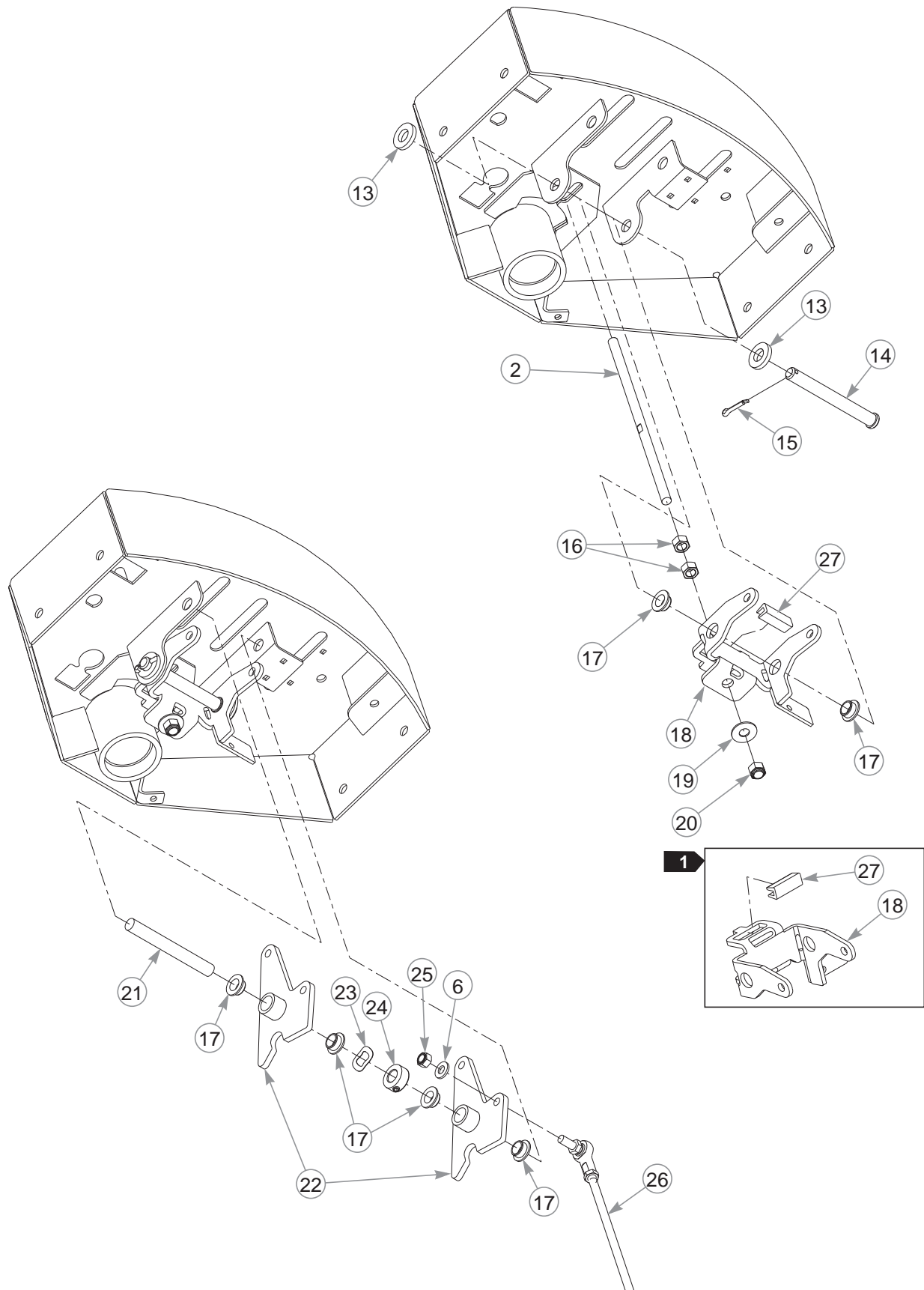

Instrument Panel

INDEX NO.	PART NO.	QTY.	DESCRIPTION
13	767962	2	FW .531 X 1.063 X .175
14	073338	1	CE .500 X 4.50 .156 X 4.34
15	017251	1	CP .156D X 1.00 LG HML Z
16	054502	6	NT .375-16 HX G5 ZNY
17	768259	6	BUSHING
18	119748	1	NEUTRAL LOCK YOKE ASSEMBLY
19	076422	1	FW .406 X 1.00 X .06 ZNYC
20	086660	1	NT .375-16 HX G5 NL
21	305086	1	PIVOT PIN
22	110639	2	BELLCRANK
23	601953	1	WASHER, WAVY .558 X 1.005
24	788554	1	LOCK COLLAR .50 X 1.00
25	058776	3	NT .312-18 HX G5 ZY NL
26	601952	2	PUMP ADJUSTMENT ROD
27	604448	1	UHMW CHANNEL

NOTES:

1. 119748 includes 604448, which can be purchased separately.

Instrument Panel

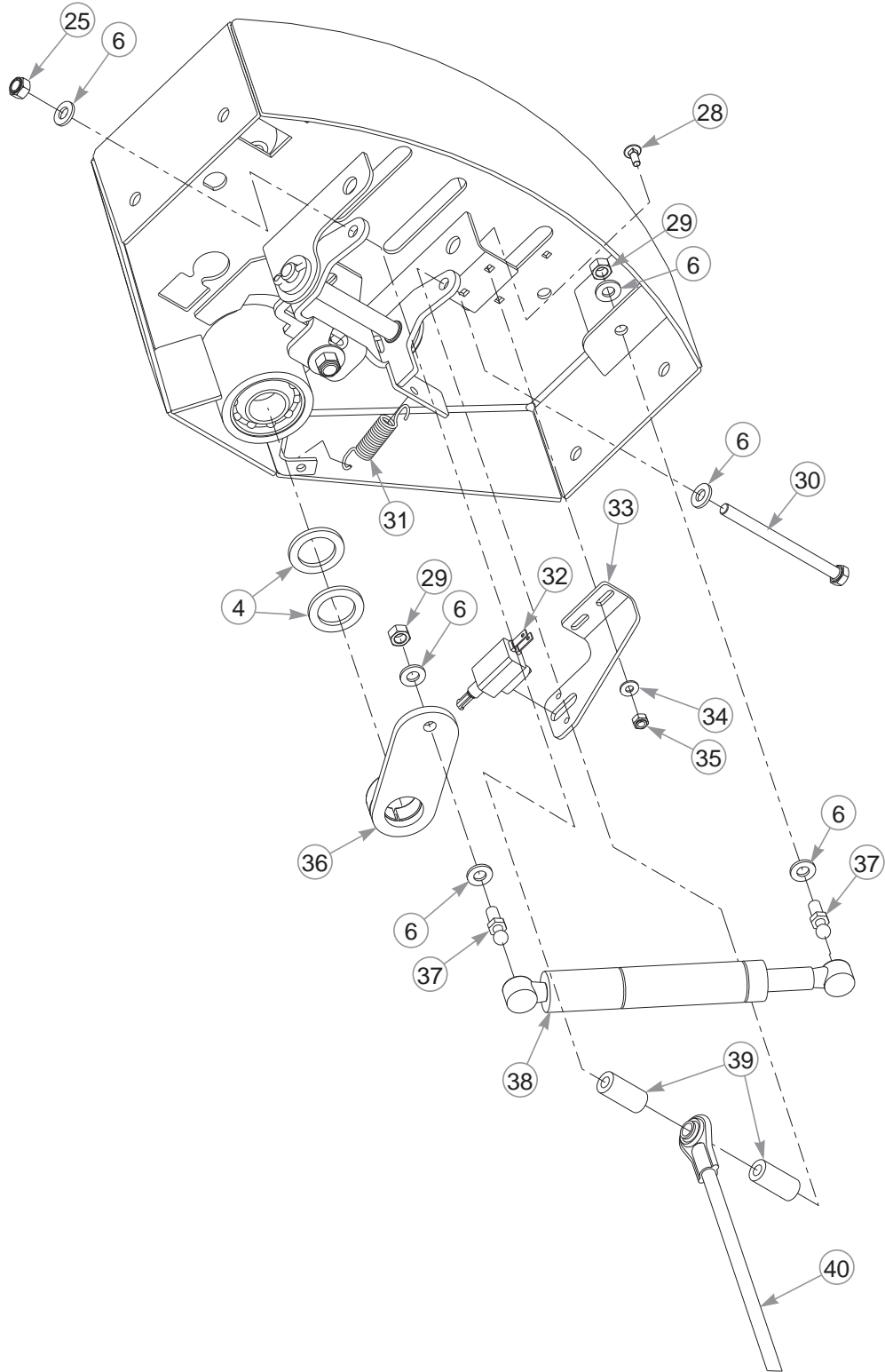

Instrument Panel

INDEX NO.	PART NO.	QTY.	DESCRIPTION
28	601098	2	CB 10-24 X .500 ZYNC
29	034272	2	NT .312-18 HX G5
30	785113	1	CS .312-18 X 4.25 HX G5
31	034652	1	SPRING 2.5
32	792374	1	SWITCH
33	110646	1	NEUTRAL SWITCH BRACKET
34	704932	2	FW .219 X .500 X .048
35	059832	2	NT #10-24 HX NL ZN
36	314351	1	ARM
37	781922	2	BALL STUD
38	788349	1	CENTERING DAMPER
39	110647	2	NEUTRAL LOCK SPACER
40	601798	1	BRAKE ROD ASSEMBLY

NOTES:

Instrument Panel

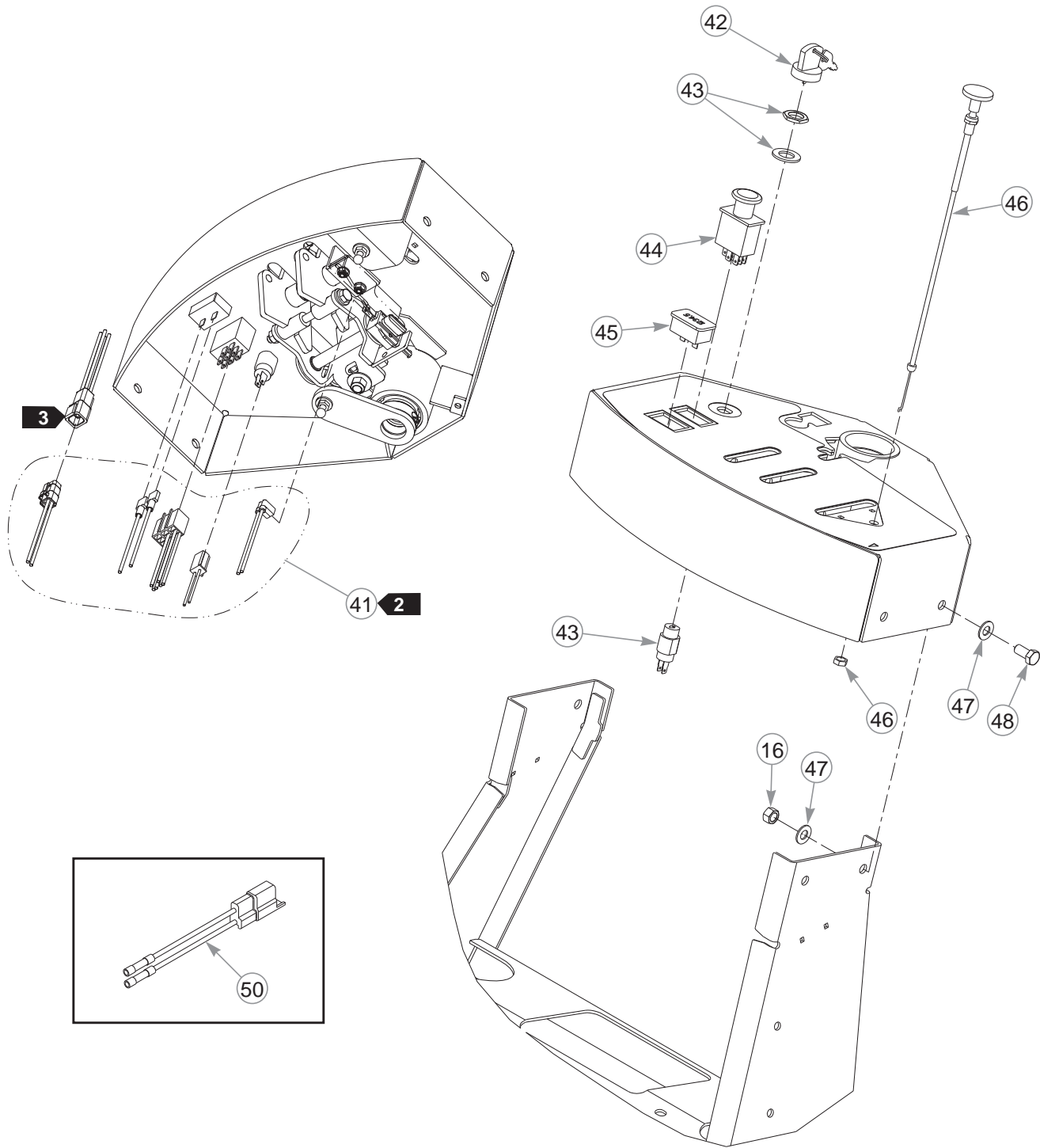

Instrument Panel

INDEX NO.	PART NO.	QTY.	DESCRIPTION
41	603314	1	WIRE HARNESS
42	785808	1	KEY ASSEMBLY
43	776518	1	IGNITION SWITCH
44	776476	1	PTO SWITCH
45	769166	1	HOUR METER
46	601097	1	CHOKE CABLE
47	767954	8	FW .379 X .813 X .063
48	055822	4	CS .375-16 X .75 HX G5
49	114052	1	CLUTCH CONNECTOR REPAIR KIT

NOTES:

2. Part of the wire harness.
3. Part of the operator presence control harness.

Instrument Panel, Electric Start

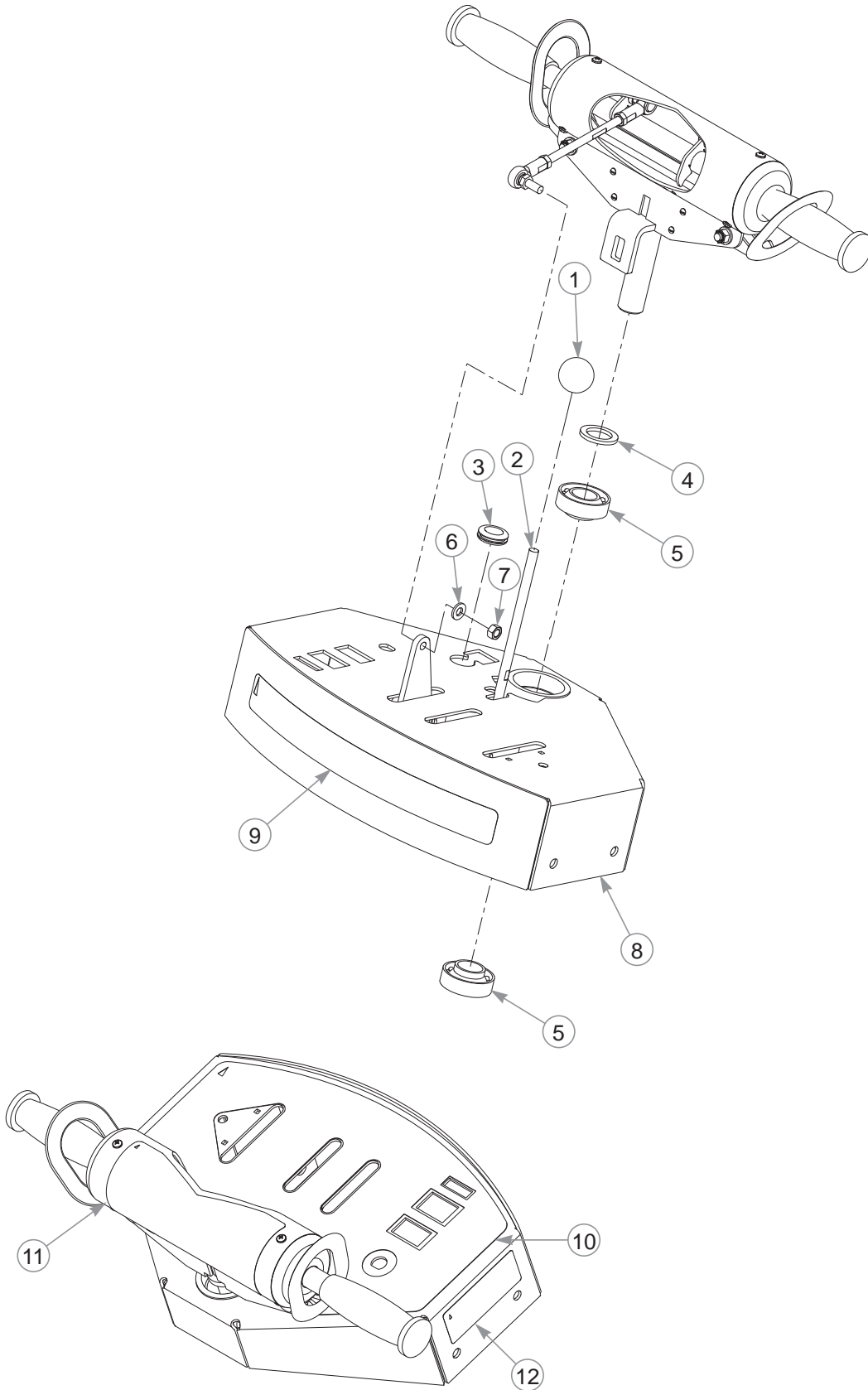

Instrument Panel, Electric Start

INDEX NO.	PART NO.	QTY.	DESCRIPTION
1	043299	1	KNOB
2	110645	1	NEUTRAL LOCK HANDLE ROD
3	047456	1	GM .750 X .188 X 1.00 X .12
4	045765	3	FW 1.030 X 1.50 X .134
5	784223	2	BEARING
6	768523	10	FW .343 X .687 X .051/.080H
7	041152	2	NT .312-24 HX ZNYC
8	550192	1	CONSOLE (WITH DECALS)
9	605669	1	TRIMSTAR ID DECAL
10	601935	1	INSTRUMENT PANEL DECAL
11	771030	1	STEERING DECAL
12	601967	1	ENGINE COMPARTMENT DECAL

NOTES:

Instrument Panel, Electric Start

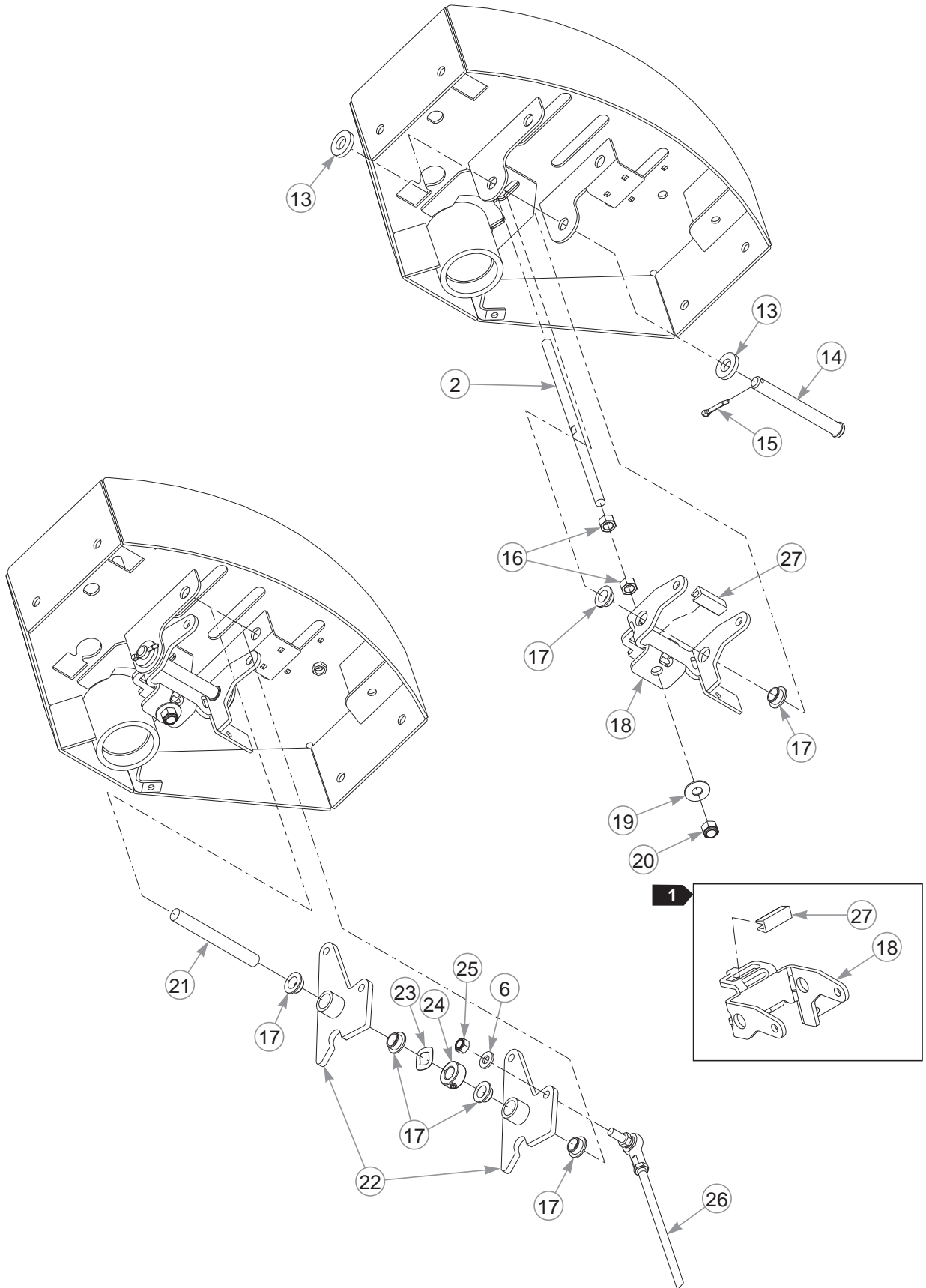

Instrument Panel, Electric Start

INDEX NO.	PART NO.	QTY.	DESCRIPTION
13	767962	2	FW .531 X 1.063 X .175
14	073338	1	CE .500 X 4.50 .156 X 4.34
15	017251	1	CP .156D X 1.00 LG HML Z
16	054502	6	NT .375-16 HX G5 ZNY
17	768259	6	BUSHING
18	119748	1	NEUTRAL LOCK YOKE ASSEMBLY
19	076422	1	FW .406 X 1.00 X .06 ZNYC
20	086660	1	NT .375-16 HX G5 NL
21	305086	1	PIVOT PIN
22	110639	2	BELLCRANK
23	601953	1	WASHER, WAVY .558 X 1.005
24	788554	1	LOCK COLLAR .50 X 1.00
25	058776	3	NT .312-18 HX G5 ZY NL
26	601952	2	PUMP ADJUSTMENT ROD
27	604448	1	UHMW CHANNEL

NOTES:

1. 119748 includes 604448, which can be purchased separately.

Instrument Panel, Electric Start

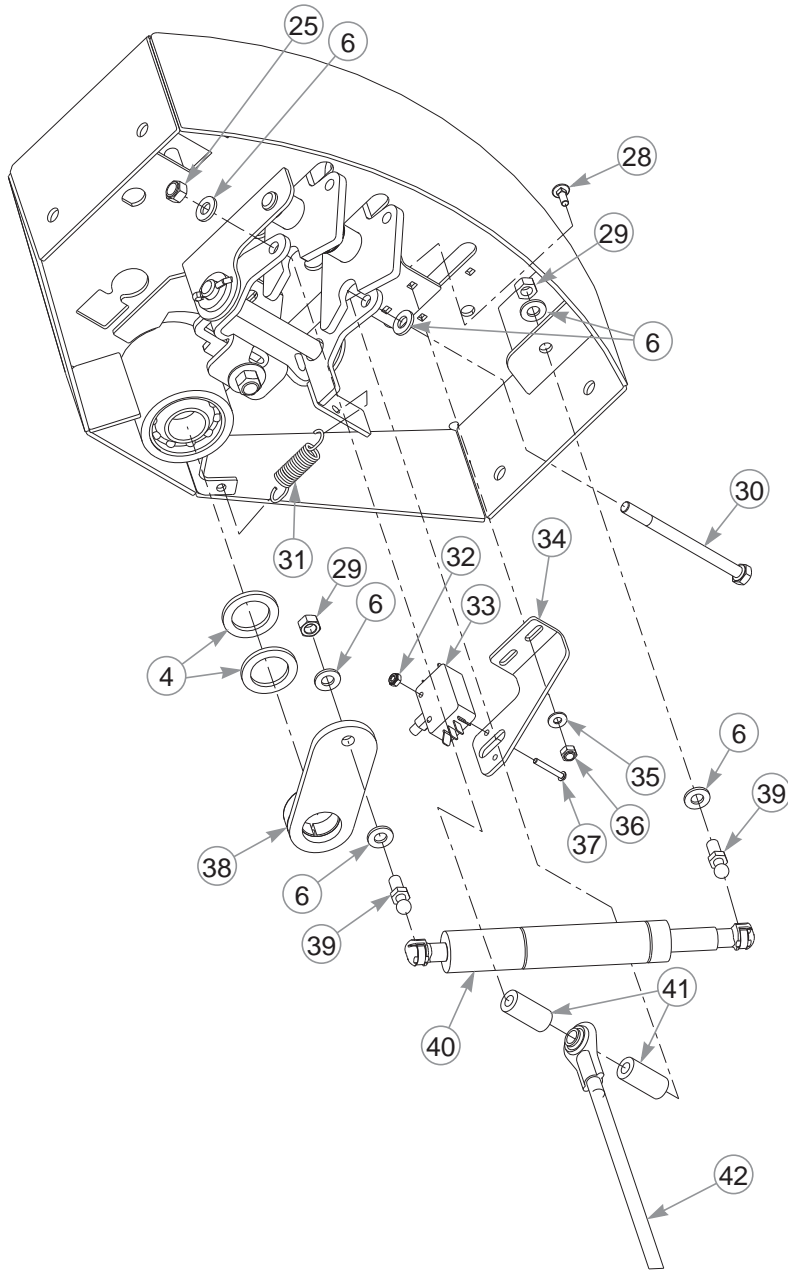

Instrument Panel, Electric Start

INDEX NO.	PART NO.	QTY.	DESCRIPTION
28	601098	6	CB 10-24 X .500 ZYNC
29	034272	2	NT .312-18 HX G5
30	785113	1	CS .312-18 X 4.25 HX G5
31	034652	1	SPRING 2.5
32	055863	2	NT # 6-32 HX NL ZN
33	023002	1	DOUBLE POLE SWITCH
34	110646	1	NEUTRAL SWITCH BRACKET
35	704932	4	FW .219 X .500 X .048
36	059832	6	NT #10-24 HX NL ZN
37	077842	2	MS # 6-32 X 1.00 RD SL
38	314351	1	ARM
39	781922	2	BALL STUD
40	788349	1	CENTERING DAMPER
41	110647	2	NEUTRAL LOCK SPACER
42	601798	1	BRAKE ROD ASSEMBLY

NOTES:

Instrument Panel, Electric Start

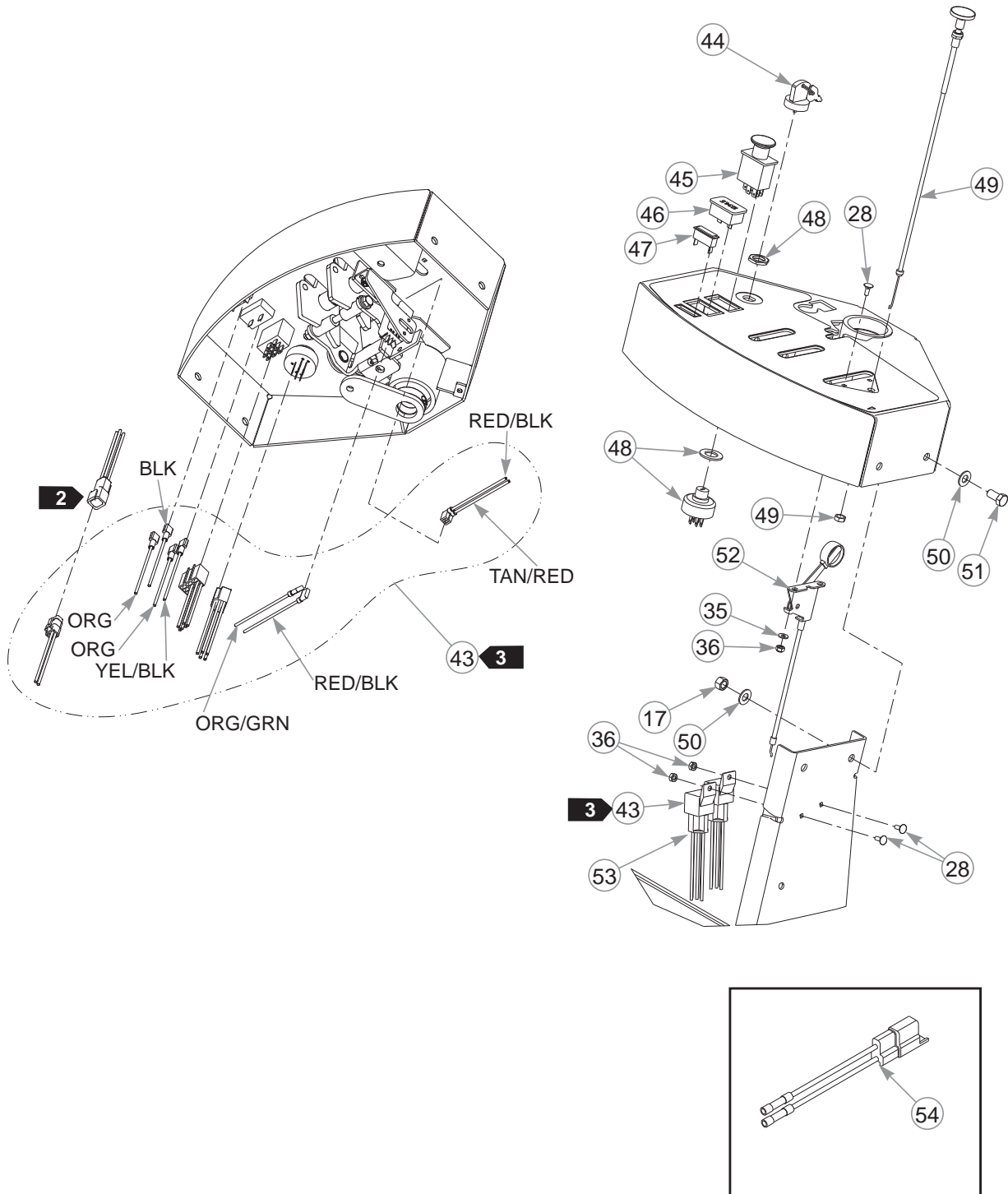

Instrument Panel, Electric Start

INDEX NO.	PART NO.	QTY.	DESCRIPTION
43	603316	1	WIRE HARNESS
44	785808	1	KEY ASSEMBLY
45	776476	1	PTO SWITCH
46	769166	1	HOUR METER
47	712257	1	RED INDICATOR LIGHT
48	045898	1	IGNITION SWITCH
49	786657	1	CHOKE CABLE
50	767954	8	FW .379 X .813 X .063
51	055822	4	CS .375-16 X .75 HX G5
52	601094	1	THROTTLE CABLE
53	601053	2	SEALED RELAY (WITH BRACKET)
54	114052	1	CLUTCH CONNECTOR REPAIR KIT

NOTES:

2. Part of the operator presence control harness.
3. Part of the wire harness.

36" Brake—S/N 13015041 & Higher

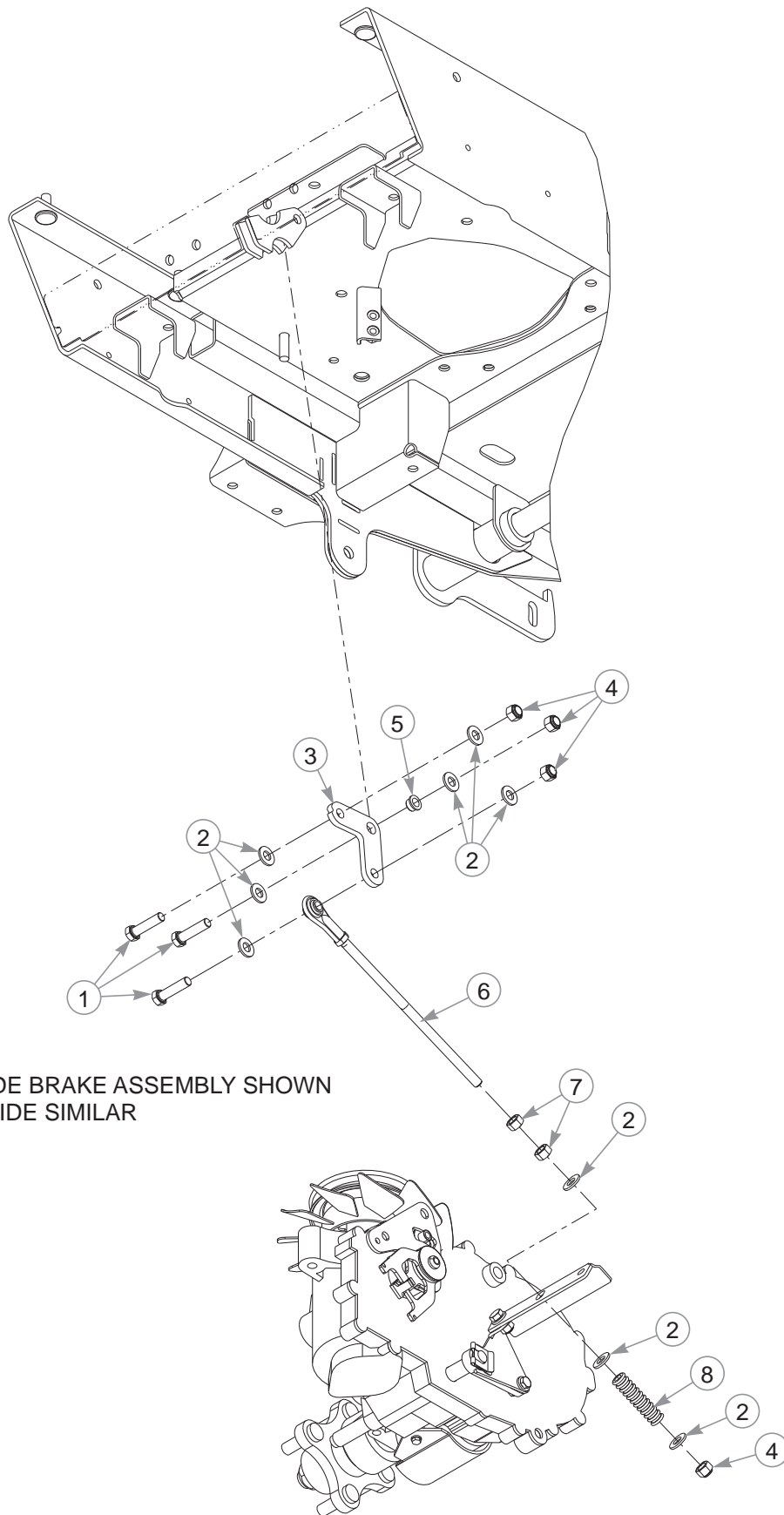

LEFT SIDE BRAKE ASSEMBLY SHOWN
RIGHT SIDE SIMILAR

36" Brake—S/N 13015041 & Higher

INDEX NO.	PART NO.	QTY	DESCRIPTION
1	080655	3	CS .375-16 X 1.50 HX G5
2	767954	9	FW .379 X .813 X .063
3	110539	1	LOWER BRAKE BELLCRANK
4	086660	4	NT .375-16 HX G5 NL
5	765339	1	BUSHING
6	601710	1	LOWER BRAKE ROD ASSEMBLY
7	054502	2	NT .375-16 HX G5 ZNY
8	784421	1	BRAKE SPRING

NOTES:

36" Brake—S/N Prior to 13015041

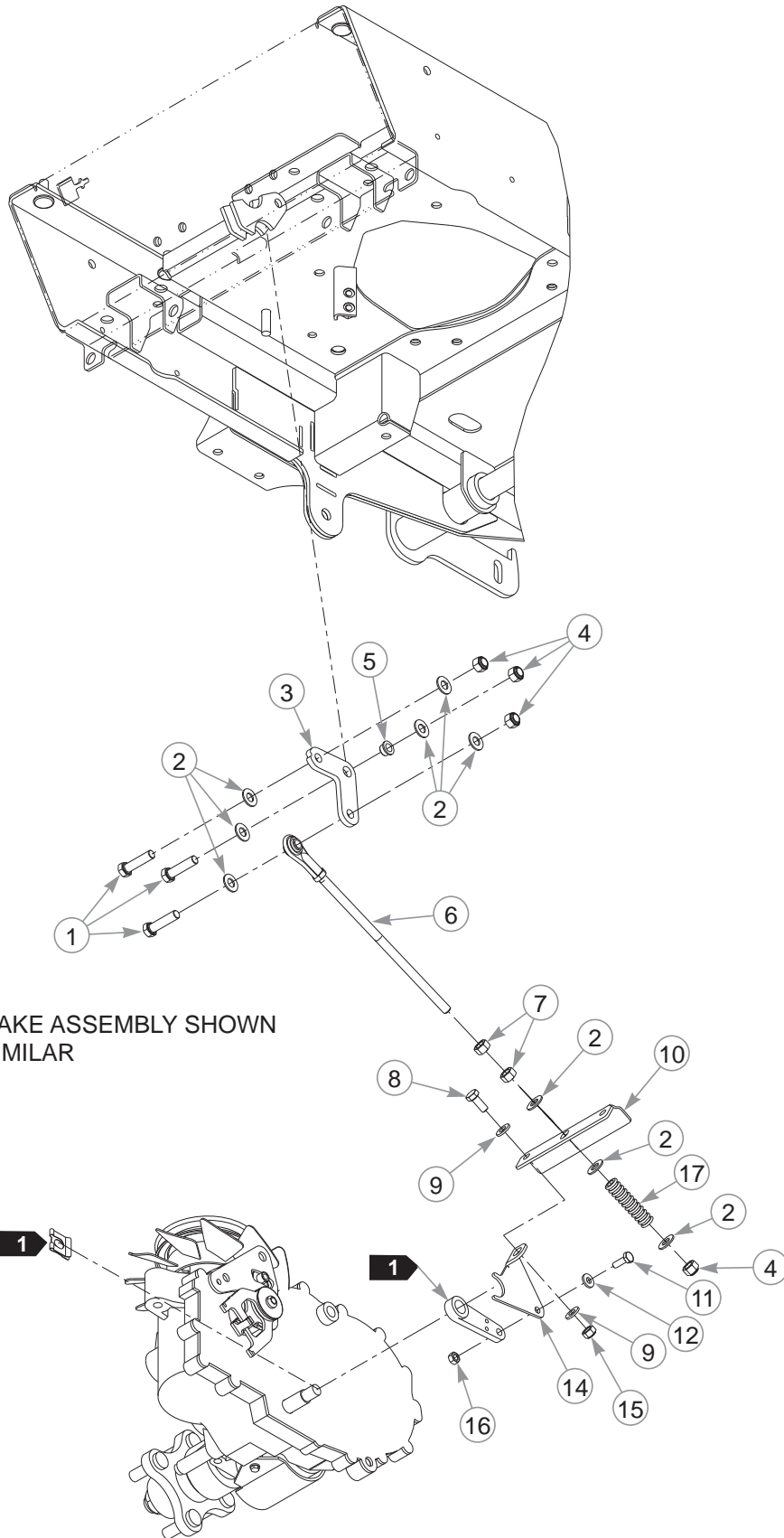

36" Brake—S/N Prior to 13015041

INDEX NO.	PART NO.	QTY.	DESCRIPTION
1	080655	3	CS .375-16 X 1.50 HX G5
2	767954	9	FW .379 X .813 X .063
3	110539	1	LOWER BRAKE BELLCRANK
4	086660	4	NT .375-16 HX G5 NL
5	765339	1	BUSHING
6	601710	1	LOWER BRAKE ROD ASSEMBLY
7	054502	2	NT .375-16 HX G5 ZNY
8	034280	2	CS .312-18 X .75 HX G5
9	768523	4	FW .343 X .687 X .066
10	110538	1	BRAKE PULL BRACKET
11	055939	2	CS .250-20 X .75 HX G5
12	768515	2	FW .281 X .625 X .051/.080H
13	109202	1	RS BRAKE SPRING LINK (NOT SHOWN)
14	109203	1	LS BRAKE SPRING LINK
15	058776	2	NT .312-18 HX G5 ZY NL
16	024927	2	NT .250-20 HX G5
17	784421	1	BRAKE SPRING

NOTES:

1. Supplied with the transmission.

48" & 54" Brake—S/N 13014137 & Higher

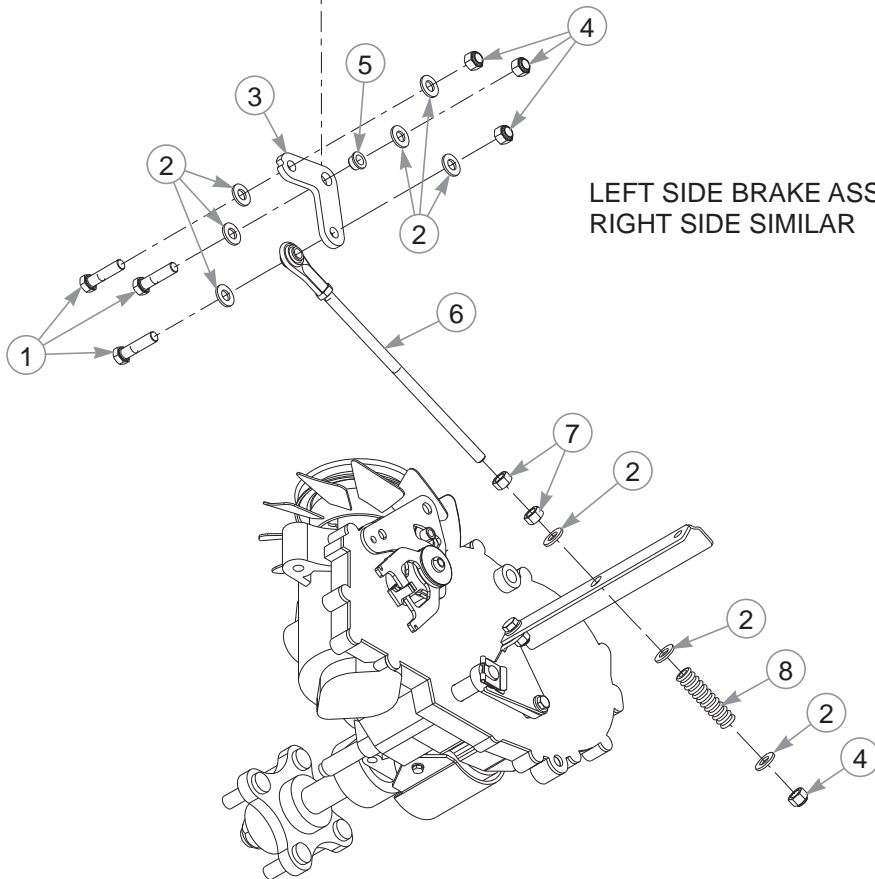
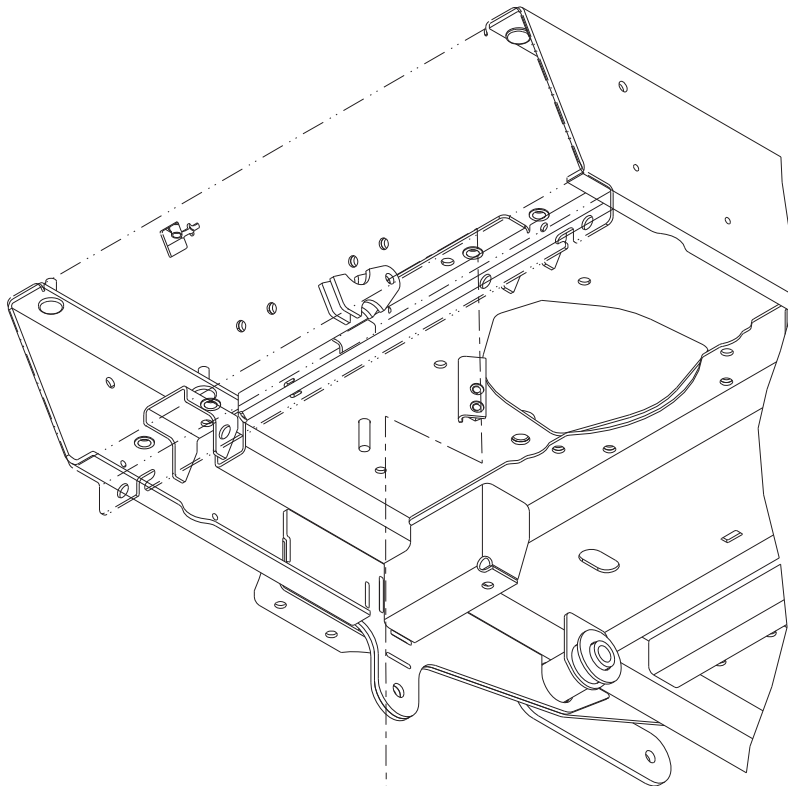

LEFT SIDE BRAKE ASSEMBLY SHOWN
RIGHT SIDE SIMILAR

48" & 54" Brake—S/N 13014137 & Higher

INDEX NO.	PART NO.	QTY	DESCRIPTION
1	080655	3	CS .375-16 X 1.50 HX G5
2	767954	9	FW .379 X .813 X .063
3	110539	1	LOWER BRAKE BELLCRANK
4	086660	4	NT .375-16 HX G5 NL
5	765339	1	BUSHING
6	601710	1	LOWER BRAKE ROD ASSEMBLY
7	054502	2	NT .375-16 HX G5 ZNY
8	784421	1	BRAKE SPRING

NOTES:

48" & 54" Brake—S/N Prior to 13014137

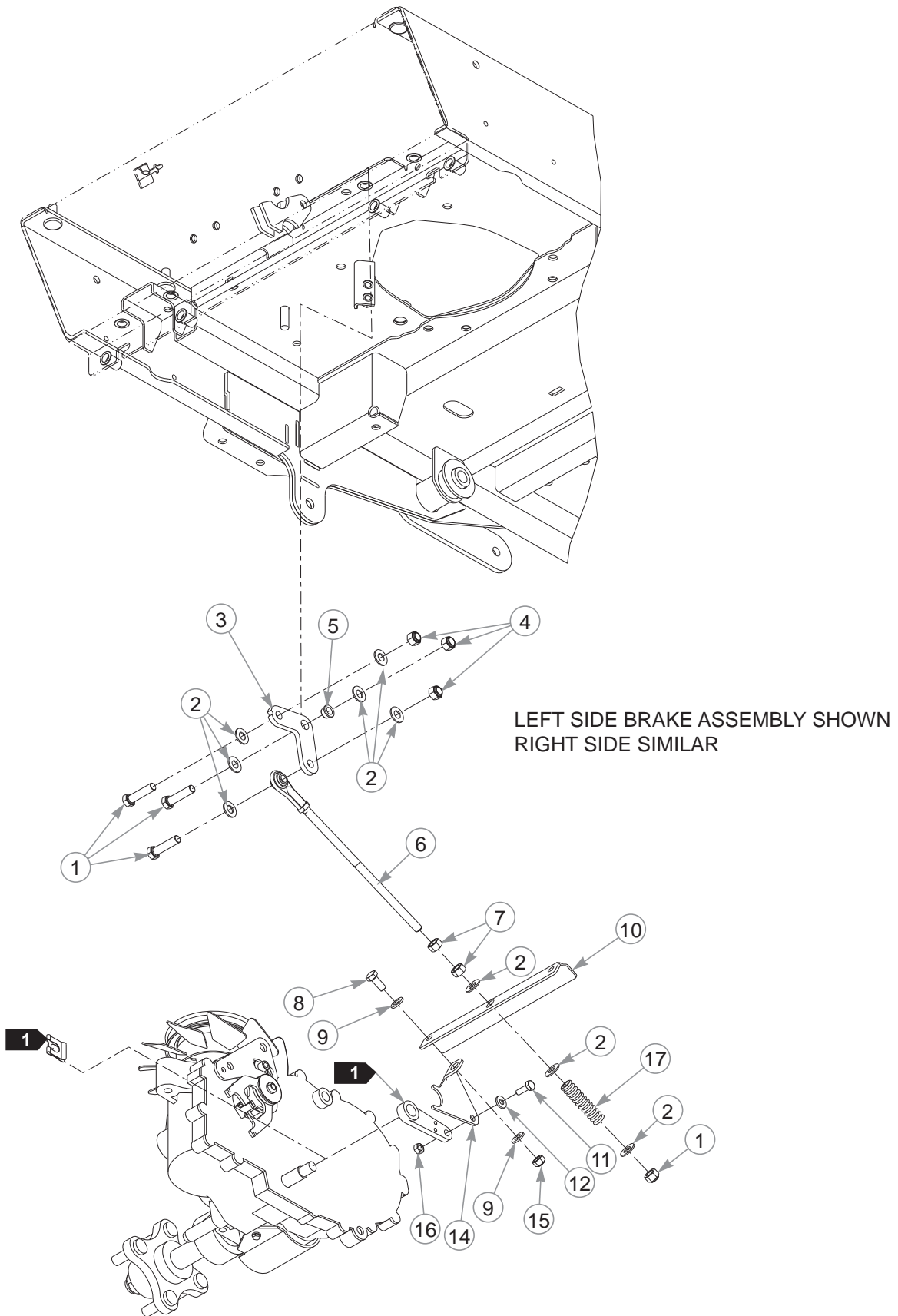

48" & 54" Brake—S/N Prior to 13014137

INDEX NO.	PART NO.	QTY.	DESCRIPTION
1	080655	3	CS .375-16 X 1.50 HX G5
2	767954	9	FW .379 X .813 X .063
3	110539	1	LOWER BRAKE BELLCRANK
4	086660	4	NT .375-16 HX G5 NL
5	765339	1	BUSHING
6	601710	1	LOWER BRAKE ROD ASSEMBLY
7	054502	2	NT .375-16 HX G5 ZNY
8	034280	2	CS .312-18 X .75 HX G5
9	768523	4	FW .343 X .687 X .051/.080H
10	110601	1	BRAKE PULL BRACKET
11	055939	2	CS .250-20 X .75 HX G5
12	768515	2	FW .281 X .625 X .066
13	109203	1	RS BRAKE SPRING LINK (NOT SHOWN)
14	109202	1	LS BRAKE SPRING LINK
15	058776	2	NT .312-18 HX G5 ZY NL
16	024927	2	NT .250-20 HX G5
17	784421	1	BRAKE SPRING

NOTES:

1. Supplied with the transmission.

Section 4

Wheel & Tire	4-2
Front Wheel Breakdown	4-4
Drive Wheel Breakdown	4-6

Wheel & Tire

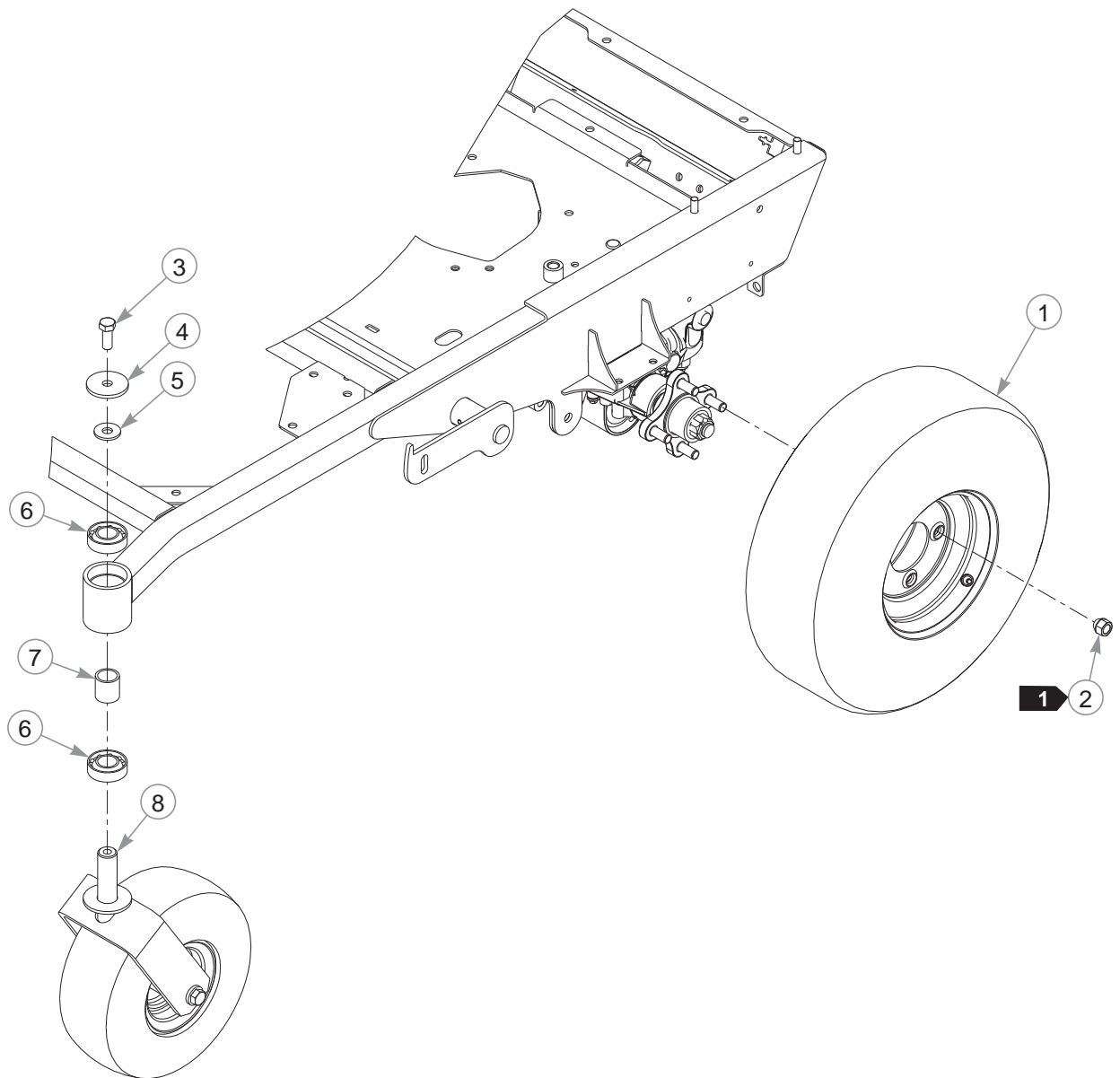

Wheel & Tire

INDEX NO.	PART NO.	QTY.	DESCRIPTION
1	785345	2	TIRE/WHEEL ASSEMBLY (36" MOWER)
	600668	2	TIRE/WHEEL ASSEMBLY (48"/54" MOWER)
2	061077	8	WHEEL NUT
3	705954	2	CS .500-13 X 1.25 HX G5
4	344267	2	FW .510 X 2.15 X .187 SPL
5	712976	2	FW .531 X 1.375 X .125
6	784223	4	BEARING
7	784603	2	SPACER
8	N/A	1	FRONT TIRE ASSEMBLY

NOTES:

1. Torque to 65–75 ft-lbs.

Front Wheel Breakdown

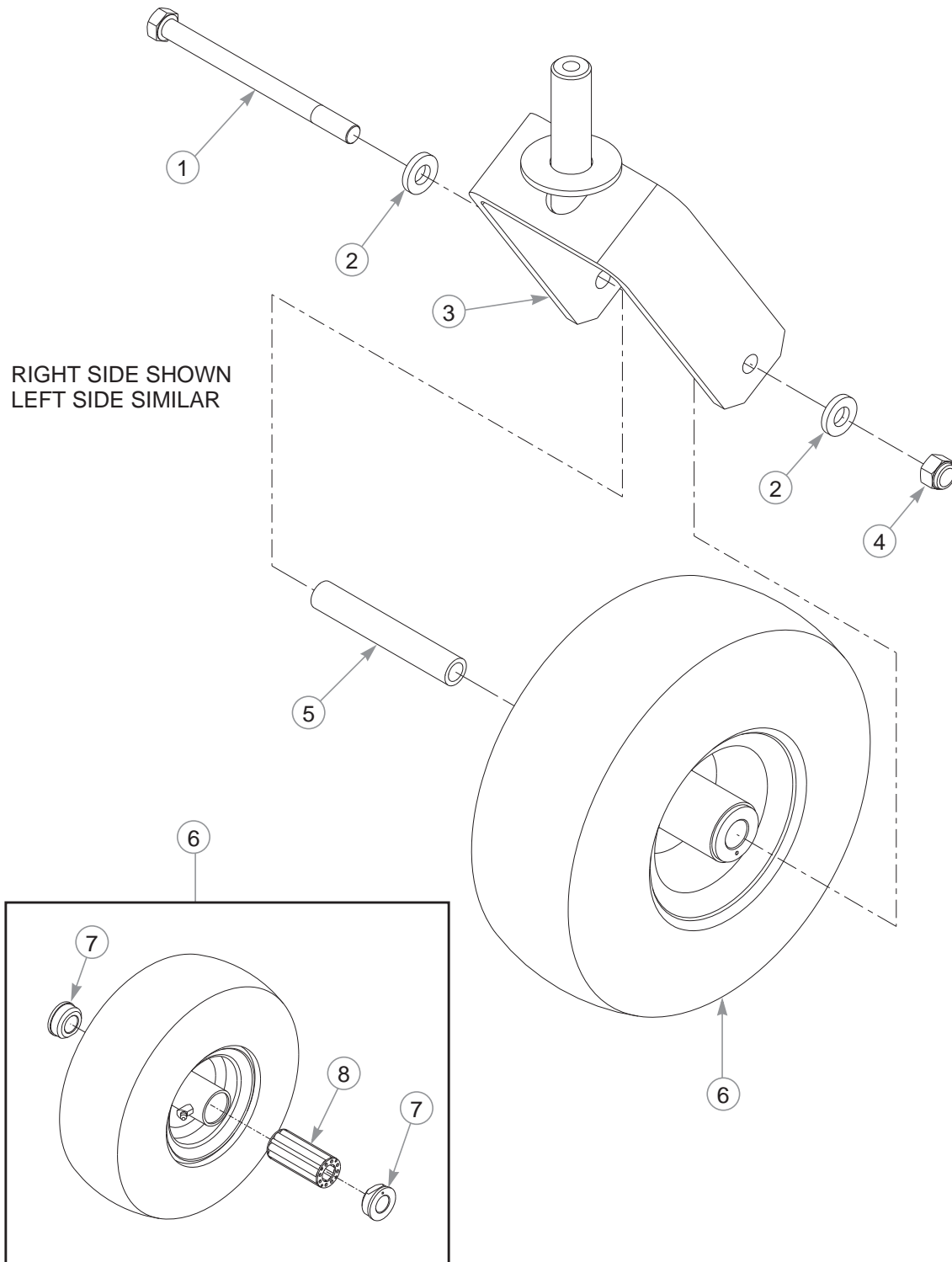

Front Wheel Breakdown

INDEX NO.	PART NO.	QTY.	DESCRIPTION
1	042630	1	CS .500-13 X 6.50 HX G5 Z
2	767962	2	FW .531 X 1.063 X .175
3	339689	1	CASTER FORK
4	781567	1	NT .500-13 HX G8 ZY NL
5	306969	1	GAUGE WHEEL SPACER
6	788604	1	TIRE/WHEEL ASSEMBLY 11 X 4-5
7	772806	2	BEARING CAP
8	772814	1	3/4" ROLLER BEARING

NOTES:

Drive Wheel Breakdown

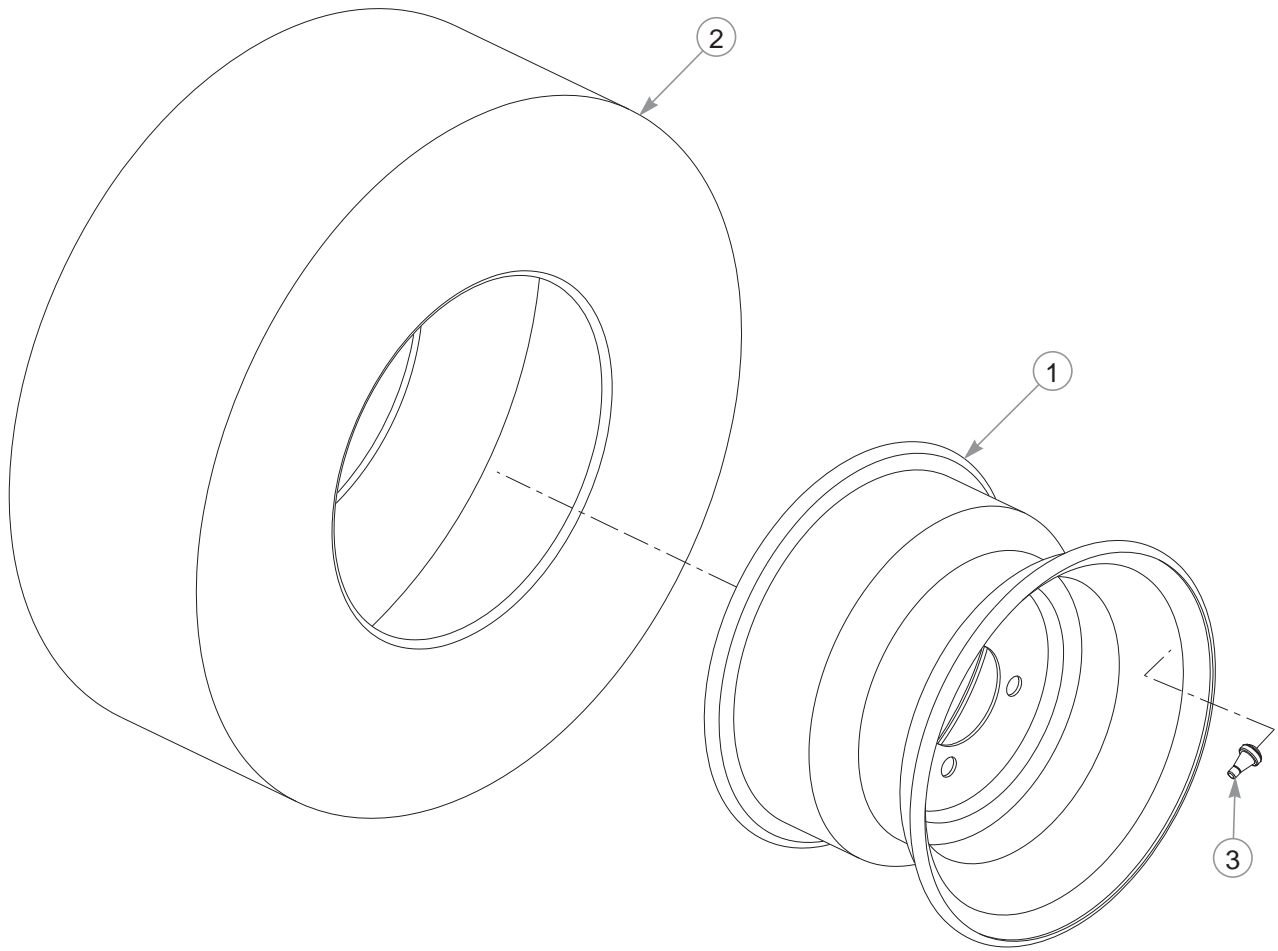

785345 TIRE/WHEEL ASSEMBLY (36" MOWER)

INDEX NO.	PART NO.	QTY	DESCRIPTION
1	785303	1	WHEEL 5.35
2	785337	1	TIRE 18 X 6.50-8
3	019521	1	VALVE STEM

600668 TIRE/WHEEL ASSEMBLY (48" & 54" MOWERS)

INDEX NO.	PART NO.	QTY	DESCRIPTION
1	600700	1	WHEEL 10 X 7
2	600684	1	TIRE 20 X 10-10
3	019521	1	VALVE STEM

NOTES:

Section 5

Engine, Kawasaki FS481V	5-2
Fuel & Vapor Lines, Kawasaki FS481V.	5-4
Engine, Kawasaki FS541V & FS600V.	5-6
Fuel & Vapor Lines, Kawasaki FS541V & FS600V	5-8
Engine, Kawasaki FS691V	5-10
Fuel & Vapor Lines, Kawasaki FS691V.	5-14
Kawasaki Engine Service Parts.	5-16
Battery	5-18
36" Fuel System w/o Carb. Canister—S/N 12081093 & Higher . . .	5-20
36" Fuel System w/o Carb. Canister—S/N Prior to 12081093	5-22
48/54" Fuel Sys. w/o Carb. Canister—S/N 12080674 & Higher . . .	5-24
48/54" Fuel Sys. w/o Carb. Canister—S/N Prior to 12080674	5-26
Fuel Tank w/o Carbon Canister Service Parts.	5-28
36" Fuel System with Carb. Canister—S/N 12111102 & Higher . . .	5-30
36" Fuel System with Carb. Canister—S/N Prior to 12111102	5-32
48/54" Fuel Sys. w/ Carb. Canister—S/N 12080854 & Higher	5-34
48/54" Fuel Sys. w/ Carb. Canister—S/N Prior to 12080854	5-36
Fuel Tank With Carbon Canister Service Parts.	5-38

Engine, Kawasaki FS481V

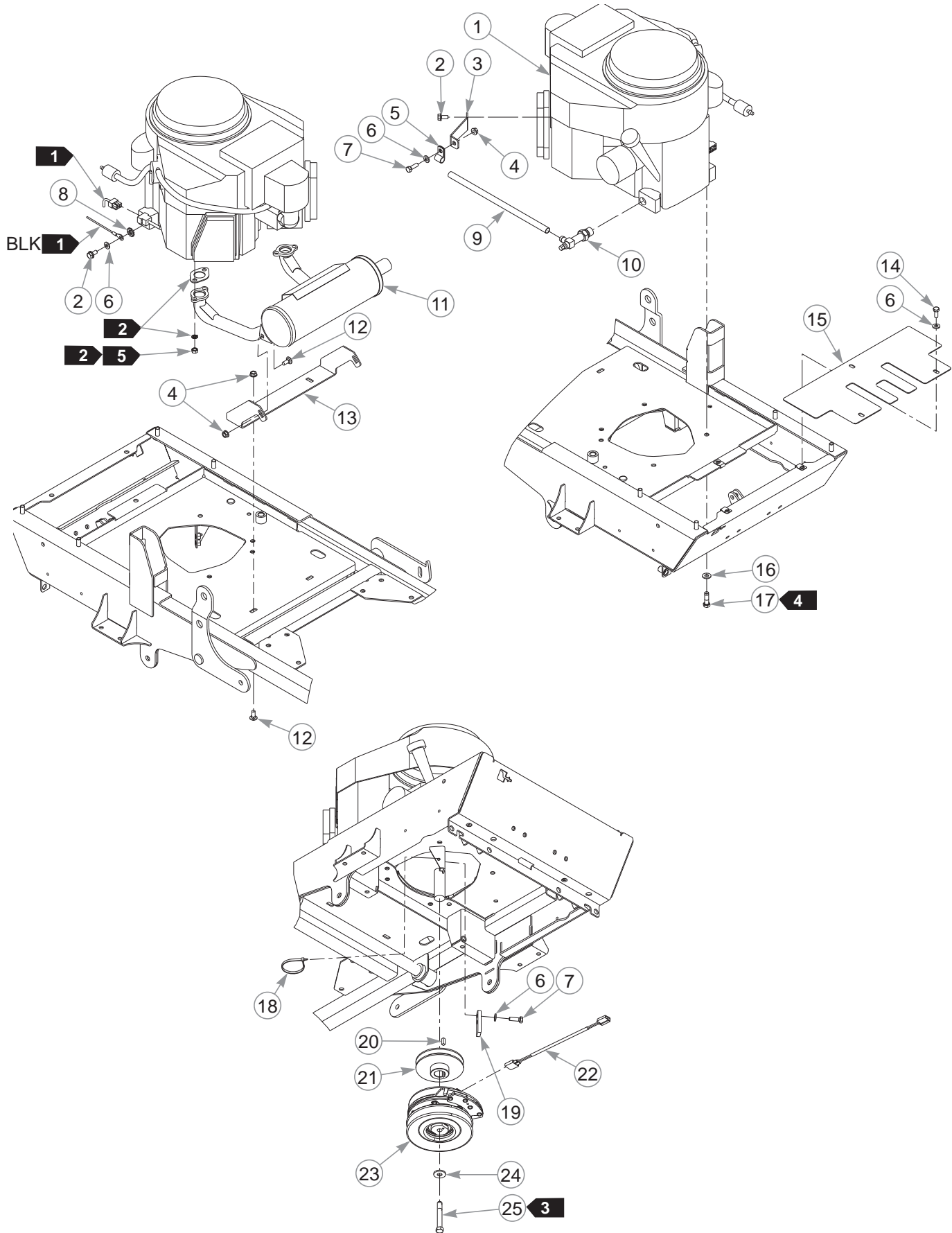

Engine, Kawasaki FS481V

INDEX NO.	PART NO.	QTY.	DESCRIPTION
1	N/A	1	KAWASAKI FS481V ENGINE
2	720516	3	CS M8 X 1.25 X 16 HX FL 10.9
3	113970	1	CABLE GUIDE
4	016832	5	NT .312-18 HX FLK ZNYC
5	000398	1	LOOP CLAMP
6	768523	7	FW .343 X .687 X .051/.080H
7	036236	3	CS .312-18 X 1.00 HX G5
8	029876	1	LW .325 INT-EXT TOOTH
9	604463	13"	OIL DRAIN HOSE
10	796524	1	OIL DRAIN VALVE
11	603187	1	MUFFLER
12	016253	4	CB .312-18 X .75 FUL ZN
13	113983	1	MUFFLER MOUNT
14	034280	3	CS .312-18 X .75 HX G5
15	110736	1	ENGINE COVER PLATE
16	767954	4	FW .379 X .813 X .063
17	602580	4	CS .375-16 X 1.25 HX G8 P85
18	000331	3	WIRE TIE
19	114571	1	CLUTCH ANCHOR
20	712372	1	KEY 1/4 SQ X .66 LG
21	799429	1	PULLEY
22	791251	1	CLUTCH HARNESS PIGTAIL
23	601325K	1	CLUTCH KIT
24	602680	1	FW .453 X 1.12 X .119 HRD
25	785048	1	CS .437-20 X 3.00 HX G5 P85

NOTES:

1. Part of the wire harness.
2. Supplied with the engine.
3. Torque to 45–48 ft-lbs. Replace (do not reuse) the cap screw if it is removed or loosened. Use only hand tools to install this fastener.
4. Torque to 30 ft-lbs. Replace (do not reuse) the cap screw if it is removed or loosened. Use only hand tools to install this fastener.
5. Torque to 22 ft-lbs.

Fuel & Vapor Lines, Kawasaki FS481V

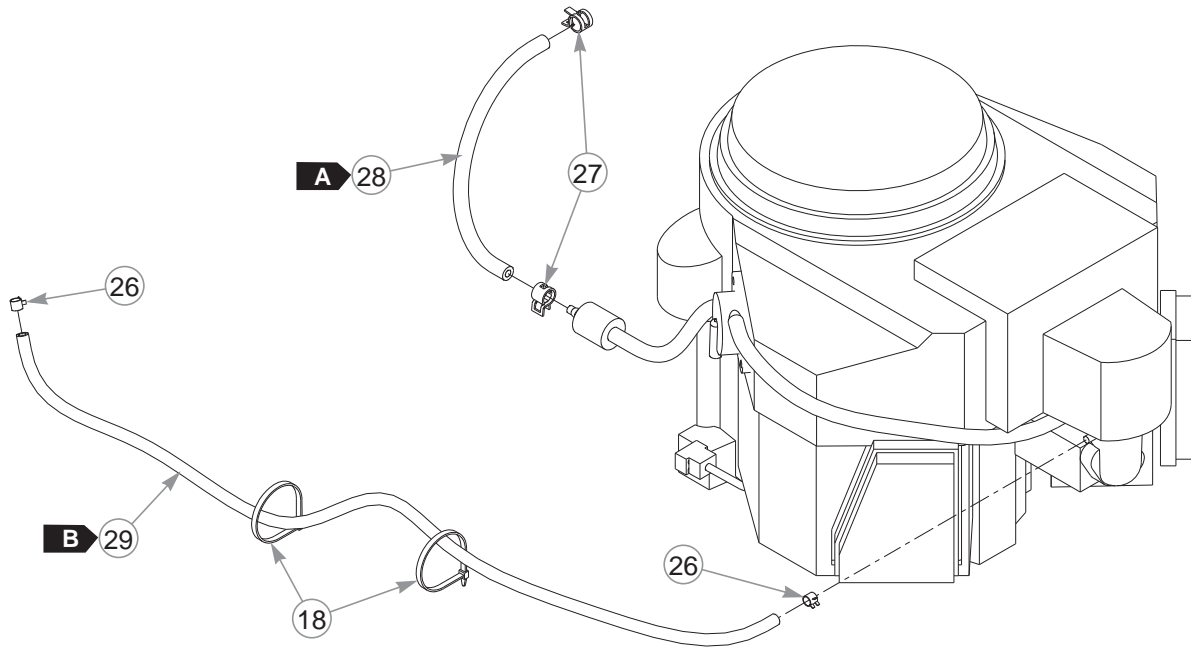

INDEX NO.	PART NO.	QTY.	DESCRIPTION
26	603112	2	3/16" HOSE CLAMP
27	000323	2	HOSE CLAMP
28	015818	12"	1/4" FUEL LINE
29	603326	34"	3/16" VAPOR LINE

NOTES:

FUEL & VAPOR LINE LENGTHS		
A	12"	FUEL FILTER TO TANK (FUEL)
B	34"	ENGINE PURGE PORT TO VACUUM BREAKER (VAPOR)

This page intentionally left blank.

Engine, Kawasaki FS541V & FS600V

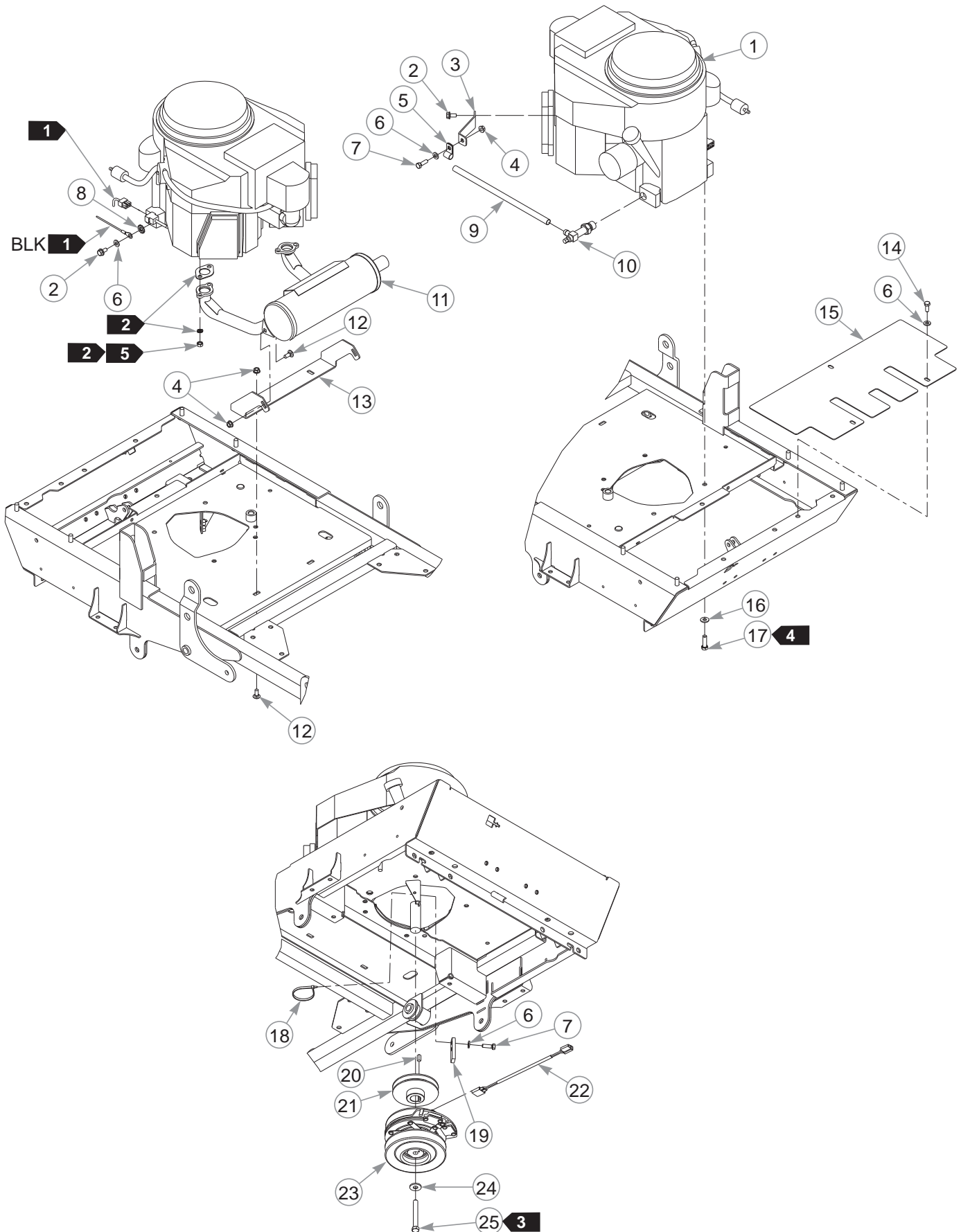

Engine, Kawasaki FS541V & FS600V

INDEX NO.	PART NO.	QTY.	DESCRIPTION
1	N/A	1	KAWASAKI FS541V & FS600V ENGINE
2	720516	3	CS M8 X 1.25 X 16 HX FL 10.9
3	113970	1	CABLE GUIDE
4	016832	5	NT .312-18 HX FLK ZNYC
5	000398	1	LOOP CLAMP
6	768523	7	FW .343 X .687 X .051/.080H
7	036236	3	CS .312-18 X 1.00 HX G5
8	029876	1	LW .325 INT-EXT TOOTH
9	604463	13"	OIL DRAIN HOSE
10	796524	1	OIL DRAIN VALVE
11	603187	1	MUFFLER
12	016253	4	CB .312-18 X .75 FUL ZN
13	113983	1	MUFFLER MOUNT
14	034280	3	CS .312-18 X .75 HX G5
15	110759	1	PULLEY COVER
16	767954	4	FW .379 X .813 X .063
17	602580	4	CS .375-16 X 1.25 HX G8 P85
18	000331	3	WIRE TIE
19	114571	1	CLUTCH ANCHOR
20	712372	1	KEY 1/4 SQ X .66 LG
21	799429	1	PULLEY
22	791251	1	CLUTCH HARNESS PIGTAIL
23	601784K	1	CLUTCH KIT
24	602680	1	FW .453 X 1.12 X .119 HRD
25	601834	1	CS .437-20 X 3.25 HX G5 P85

NOTES:

1. Part of the wire harness.
2. Supplied with the engine.
3. Torque to 45–48 ft-lbs. Replace (do not reuse) the cap screw if it is removed or loosened. Use only hand tools to install this fastener.
4. Torque to 30 ft-lbs. Replace (do not reuse) the cap screw if it is removed or loosened. Use only hand tools to install this fastener.
5. Torque to 22 ft-lbs.

Fuel & Vapor Lines, Kawasaki FS541V & FS600V

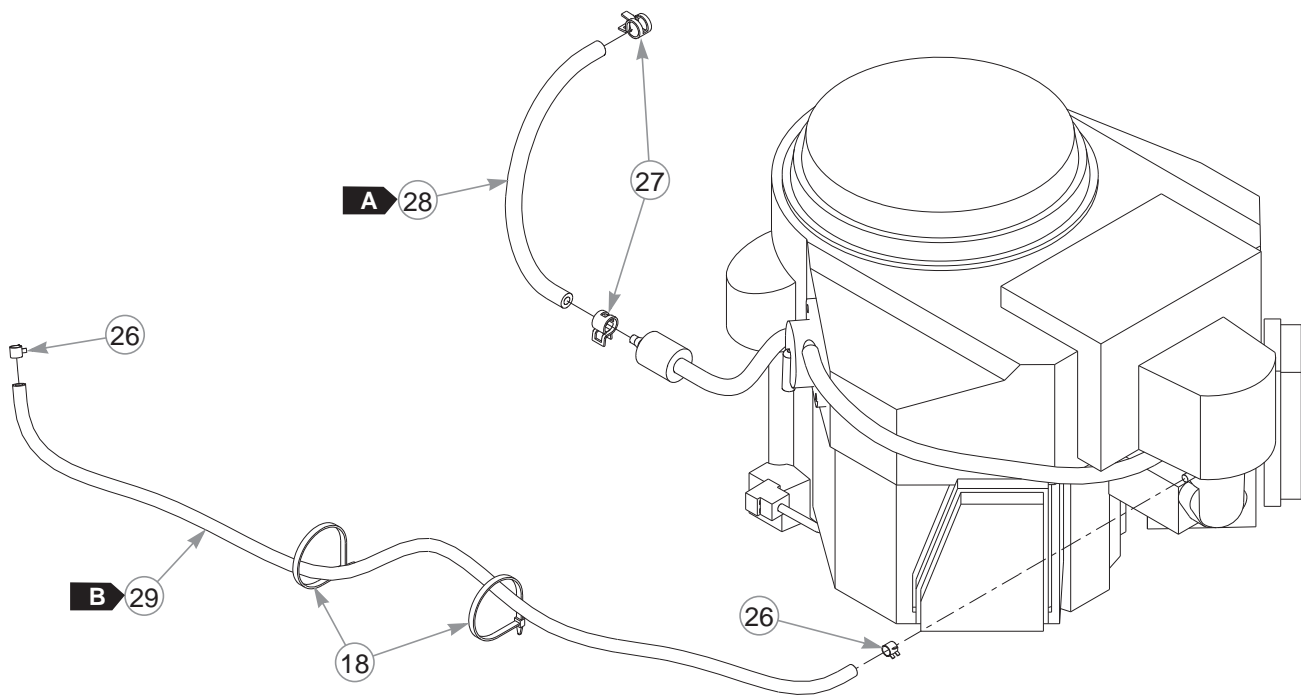

INDEX NO.	PART NO.	QTY.	DESCRIPTION
26	603112	2	3/16" HOSE CLAMP
27	000323	2	HOSE CLAMP
28	015818	12"	1/4" FUEL LINE
29	603326	34"	3/16" VAPOR LINE

NOTES:

FUEL & VAPOR LINE LENGTHS		
A	12"	FUEL FILTER TO TANK (FUEL)
B	34"	ENGINE PURGE PORT TO VACUUM BREAKER (VAPOR)

This page intentionally left blank.

Engine, Kawasaki FS691V

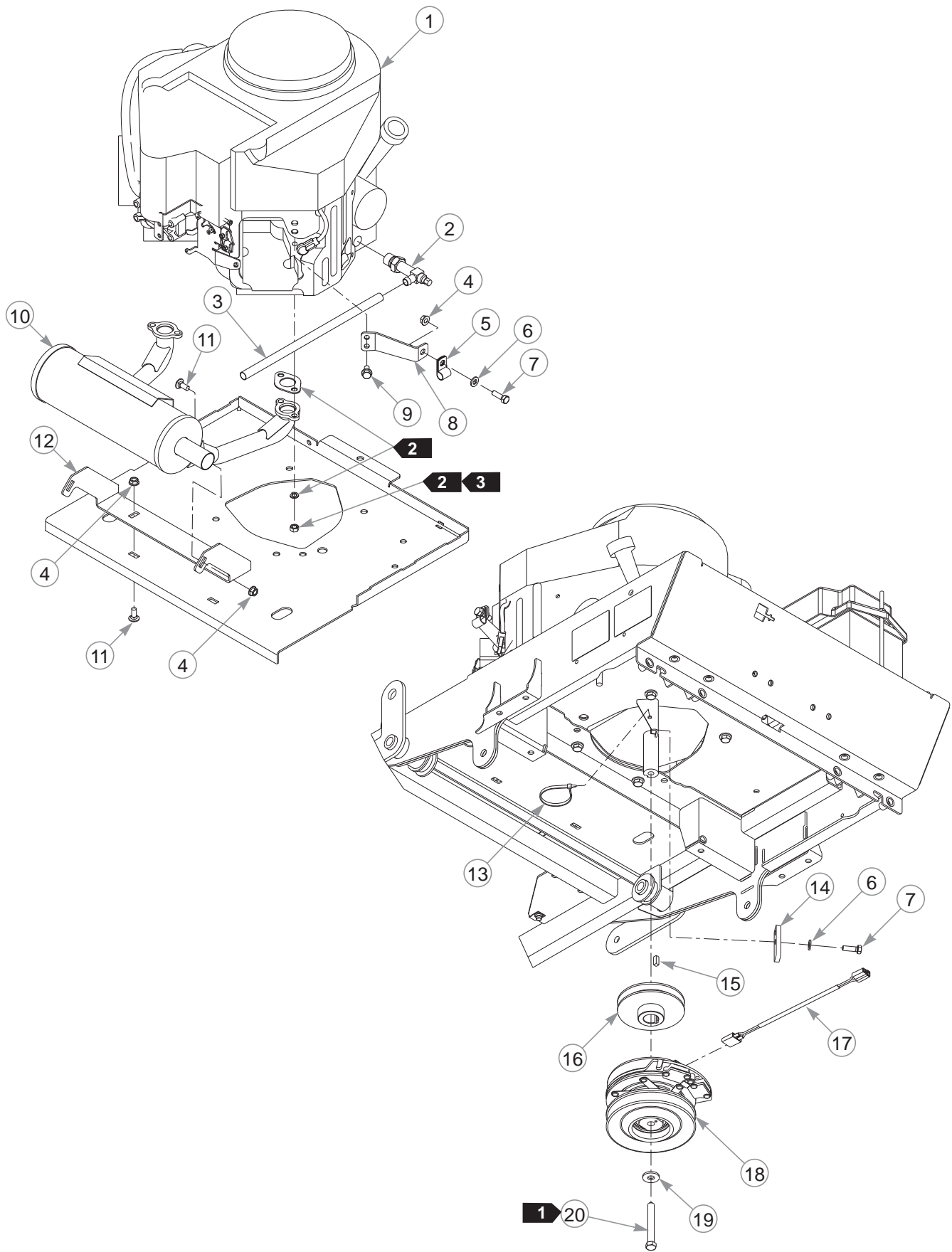

Engine, Kawasaki FS691V

INDEX NO.	PART NO.	QTY.	DESCRIPTION
1	N/A	1	KAWASAKI FS691V ENGINE
2	796524	1	OIL DRAIN VALVE
3	604463	13"	OIL DRAIN HOSE
4	016832	5	NT .312-18 HX FLK ZNYC
5	000398	1	LOOP CLAMP
6	768523	7	FW .343 X .687 X .051/.080H
7	036236	3	CS .312-18 X 1.00 HX G5
8	113970	1	CABLE GUIDE
9	720516	3	CS M8 X 1.25 X 16 HX FL 10.9
10	603188	1	MUFFLER
11	016253	4	CB .312-18 X .75 FUL ZN
12	113983	1	MUFFLER MOUNT
13	000331	3	WIRE TIE
14	114571	1	CLUTCH ANCHOR
15	712372	1	KEY 1/4 SQ X .66 LG
16	799429	1	PULLEY
17	791251	1	CLUTCH HARNESS PIGTAIL
18	601784K	1	CLUTCH KIT
19	602680	1	FW .453 X 1.12 X .119 HRD
20	601834	1	CS .437-20 X 3.25 HX G5 P85

NOTES:

1. Torque to 45–48 ft-lbs. Replace (do not reuse) the cap screw if it is removed or loosened. Use only hand tools to install this fastener.
2. Supplied with the engine.
3. Torque to 22 ft-lbs.

Engine, Kawasaki FS691V

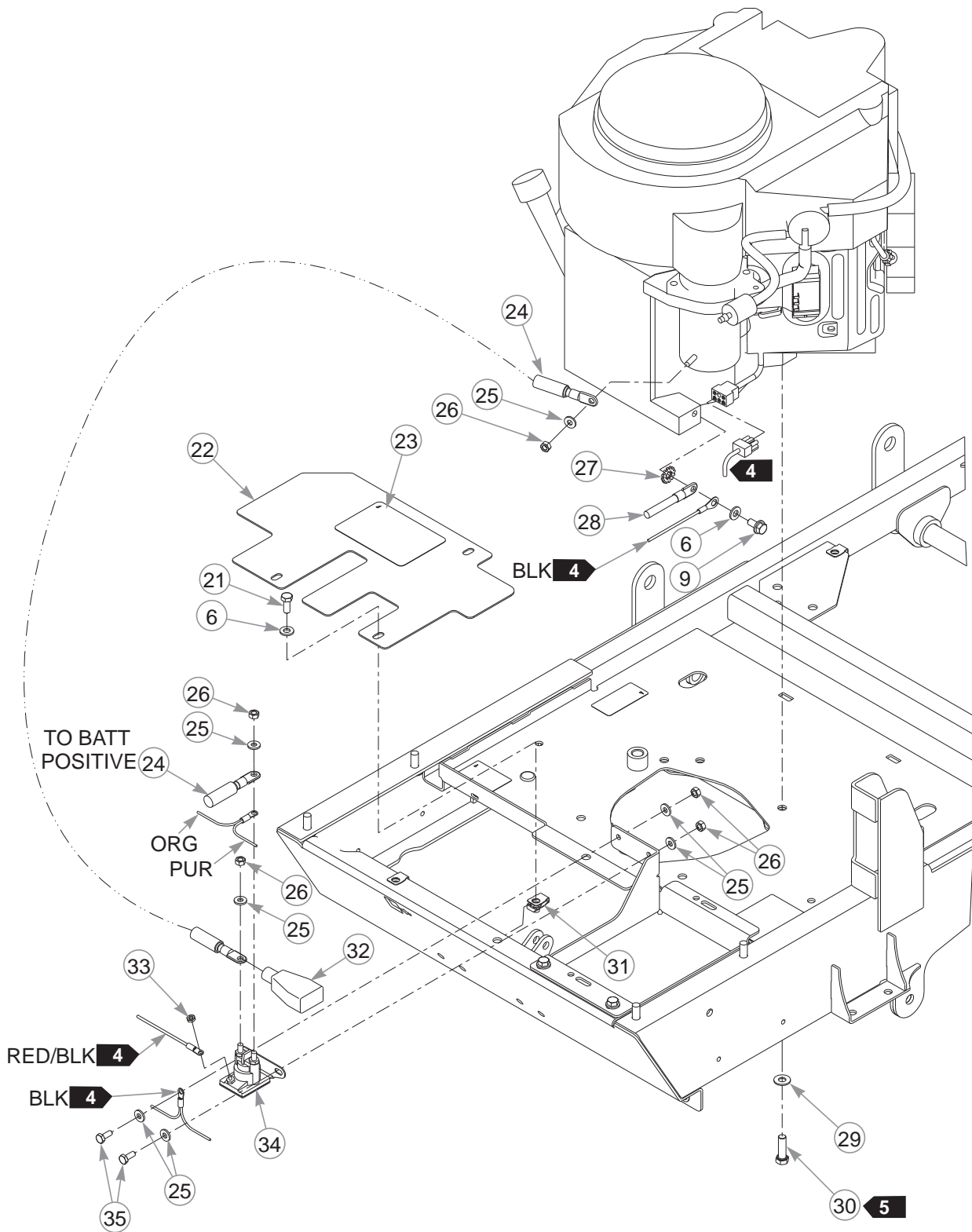

Engine, Kawasaki FS691V

INDEX NO.	PART NO.	QTY.	DESCRIPTION
21	034280	3	CS .312-18 X .75 HX G5
22	550191	1	PULLEY COVER (WITH DECAL)
23	601815	1	BATTERY WARNINGS DECAL
24	792762	2	POSITIVE BATTERY CABLE
25	768515	7	FW .281 X .625 X .066
26	024927	5	NT .250-20 HX G5
27	029876	1	LW .325 INT-EXT TOOTH
28	780015	1	NEGATIVE BATTERY CABLE
29	767954	4	FW .379 X .813 X .063
30	602580	4	CS .375-16 X 1.25 HX G8 P85
31	601069	1	CN .312-18 X .20 MAX THK
32	771428	1	RED BATTERY CABLE BOOT
33	044255	1	NT #10-32 HX ZN
34	030817	1	STARTER SOLENOID
35	064329	2	CS .250-20 X .625 HX G5

NOTES:

4. Part of the wire harness.
5. Torque to 30 ft-lbs. Replace (do not reuse) the cap screw if it is removed or loosened. Use only hand tools to install this fastener.

Fuel & Vapor Lines, Kawasaki FS691V

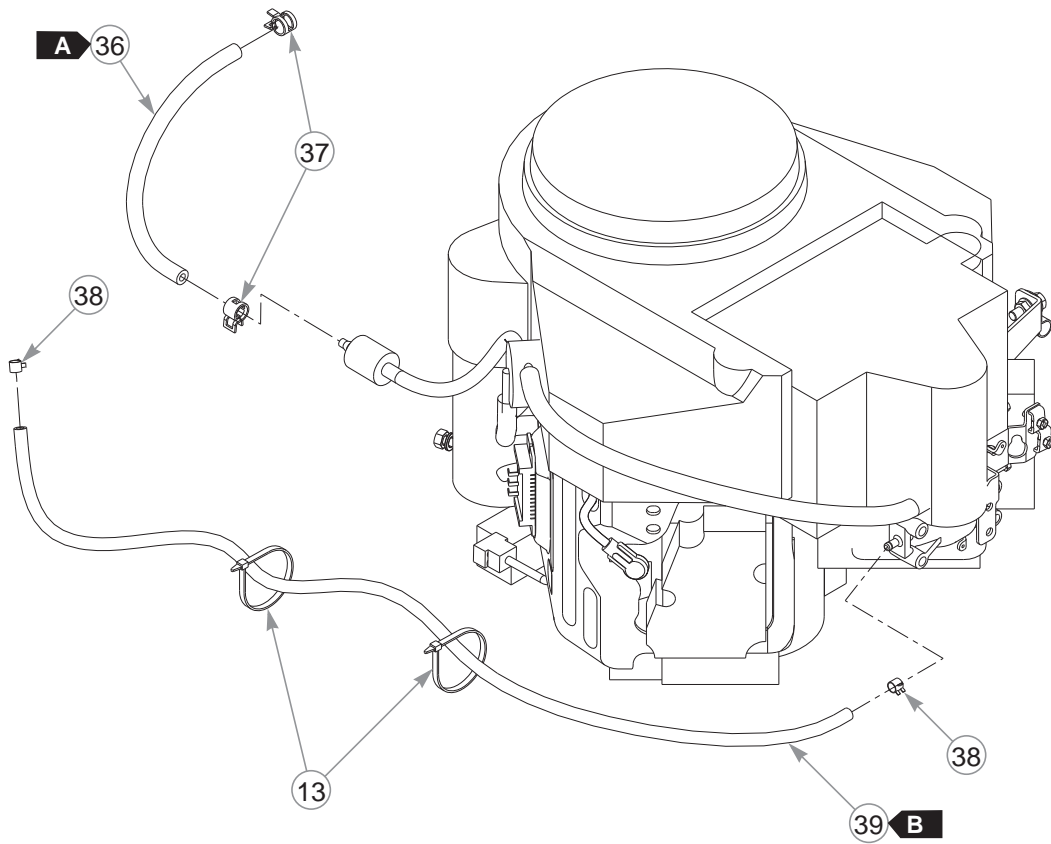

Fuel & Vapor Lines, Kawasaki FS691V

INDEX NO.	PART NO.	QTY.	DESCRIPTION
36	015818	12"	1/4" FUEL LINE
37	000323	2	HOSE CLAMP
38	603112	2	3/16" HOSE CLAMP
39	603326	34"	3/16" VAPOR LINE

NOTES:

LINE LENGTHS		
A	12"	TANK TO FILTER (FUEL)
B	34"	ENGINE TO VACUUM BREAKER (VAPOR)

Kawasaki Engine Service Parts

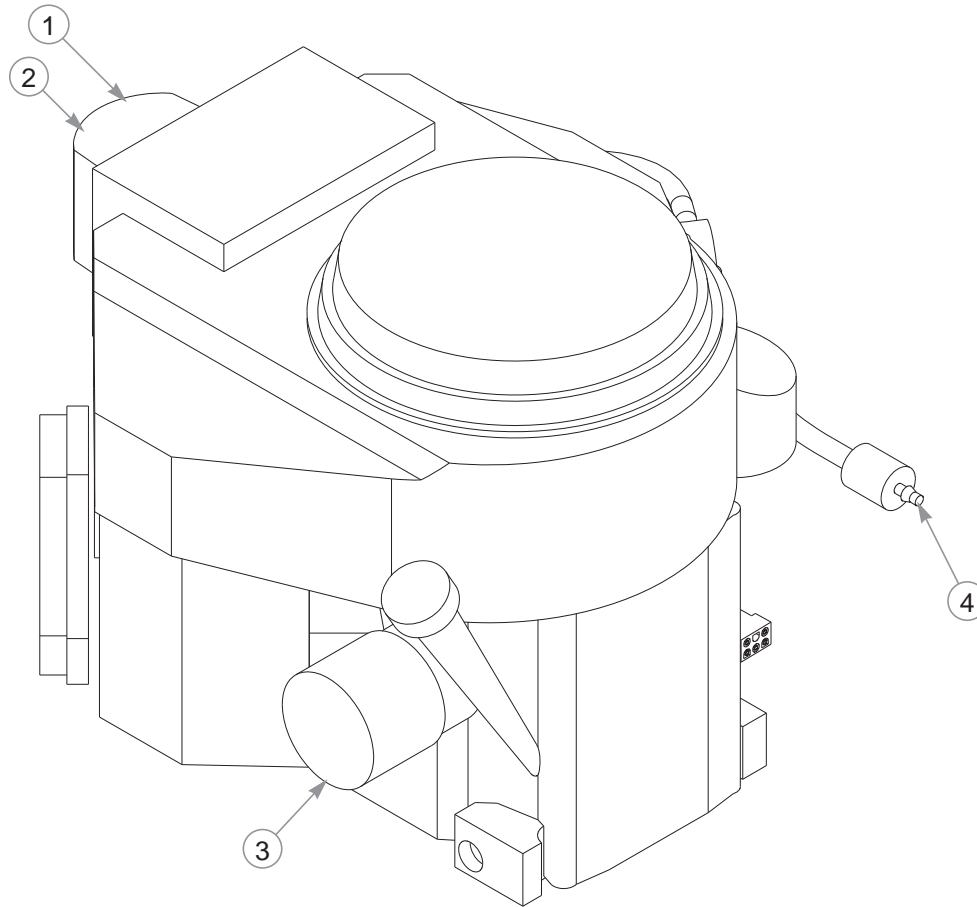

INDEX NO.	PART NO.	QTY.	DESCRIPTION
1	603058	1	PRE FILTER
2	603059	1	AIR FILTER
3	602581	1	OIL FILTER
4	068478	1	IN-LINE FUEL FILTER

NOTES:

This page intentionally left blank.

Battery

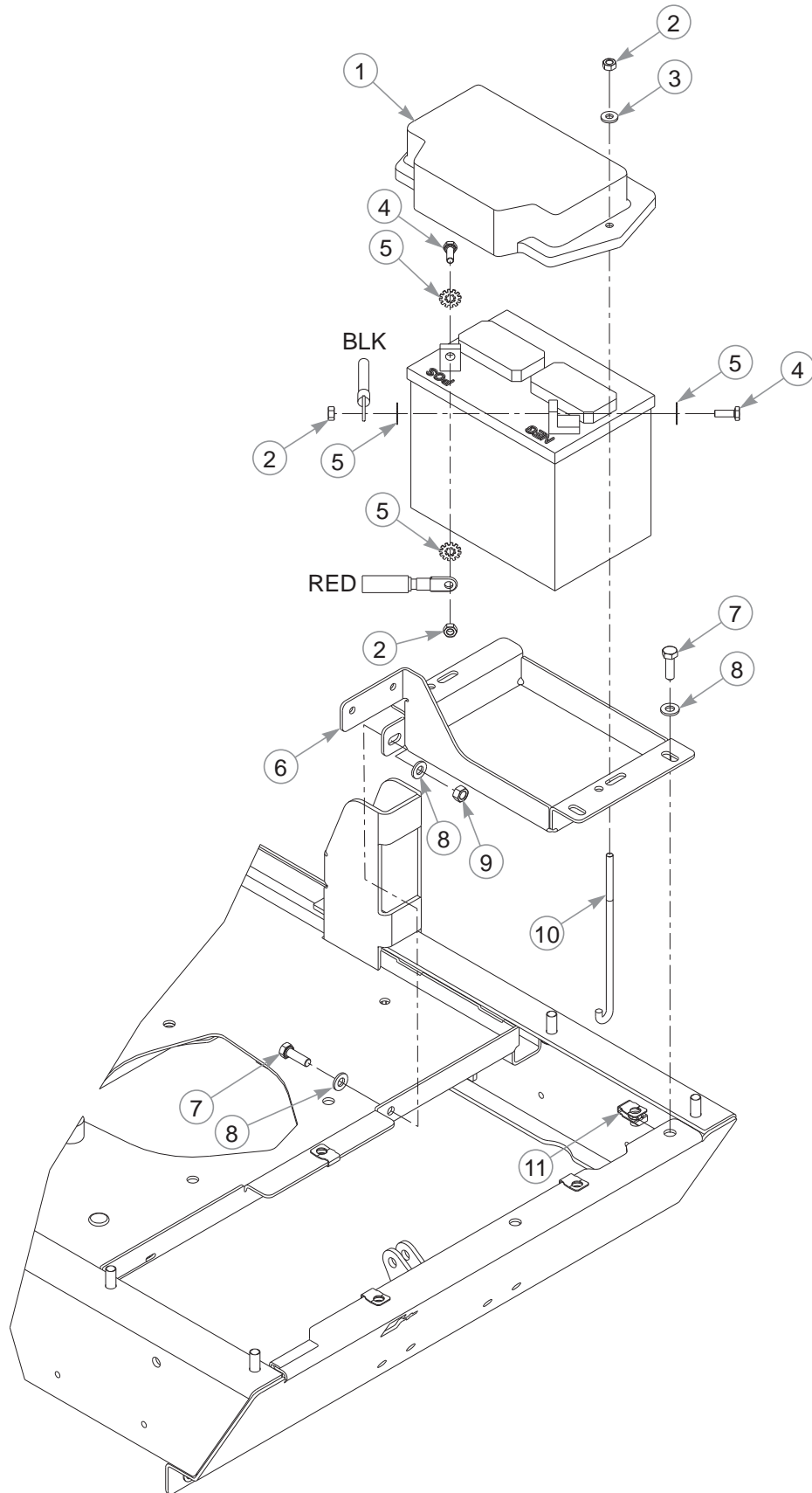

Battery

INDEX NO.	PART NO.	QTY.	DESCRIPTION
1	745166	1	BATTERY HOLD DOWN COVER
2	024927	4	NT .250-20 HX G5
3	768515	2	FW .281 X .625 X .066
4	055939	2	CS .250-20 X .75 HX G5
5	029868	4	LW .250 INT-EXT TOOTH Z
6	110865	1	BATTERY BOX
7	036236	3	CS .312-18 X 1.00 HX G5
8	768523	4	FW .343 X .687 X .051/.080H
9	034272	1	NT .312-18 HX G5
10	793489	2	BATTERY CLAMP ROD
11	601069	1	CN .312-18 X .20 MAX THK
12	000331	1	WIRE TIE (NOT SHOWN)

NOTES:

36" Fuel System w/o Carb. Canister—S/N 12081093 & Higher

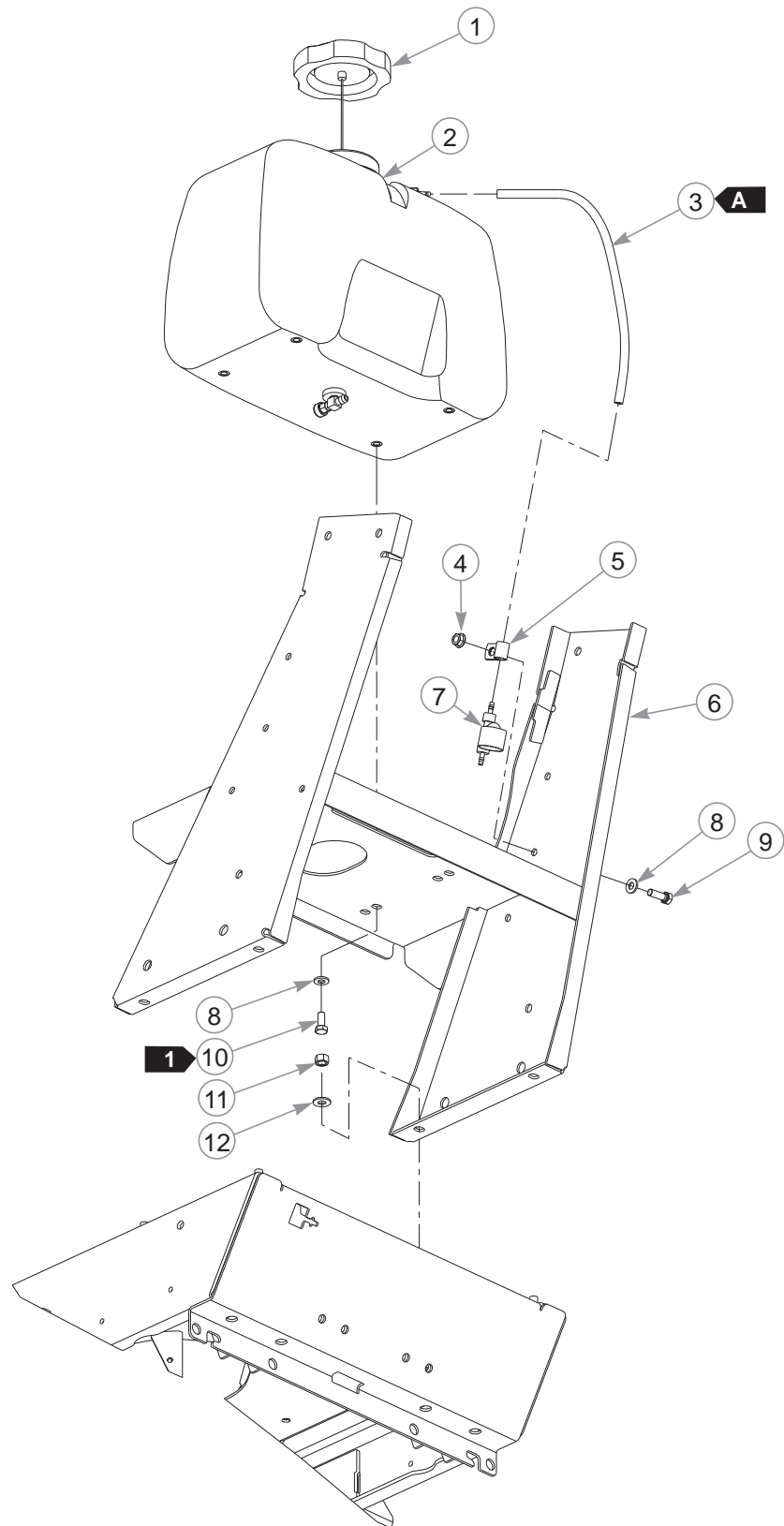

36" Fuel System w/o Carb. Canister—S/N 12081093 & Higher

INDEX NO.	PART NO.	QTY.	DESCRIPTION
1	602916	1	RATCHETING GAS CAP, 3.5"
2	605097	1	FUEL TANK ASSEMBLY (S/N 14043116 & HIGHER)
	604056	1	FUEL TANK ASSEMBLY (S/N 12081093–14043115)
3	603326	14"	3/16" VAPOR LINE
4	016832	1	NT .312-18 HX FLK ZNYC
5	000398	1	LOOP CLAMP
6	110511	1	CONSOLE SUPPORT
7	604305	1	VACUUM BREAKER
8	768523	5	FW .343 X .687 X .051/.080H
9	036236	1	CS .312-18 X 1.00 HX G5
10	034280	4	CS .312-18 X .75 HX G5
11	054502	4	NT .375-16 HX G5 ZNY
12	767954	4	FW .379 X .813 X .063

NOTES:

LINE LENGTHS		
A	14"	TANK TO VACUUM BREAKER (VAPOR)

1. Torque to 7 ft-lbs.

36" Fuel System w/o Carb. Canister—S/N Prior to 12081093

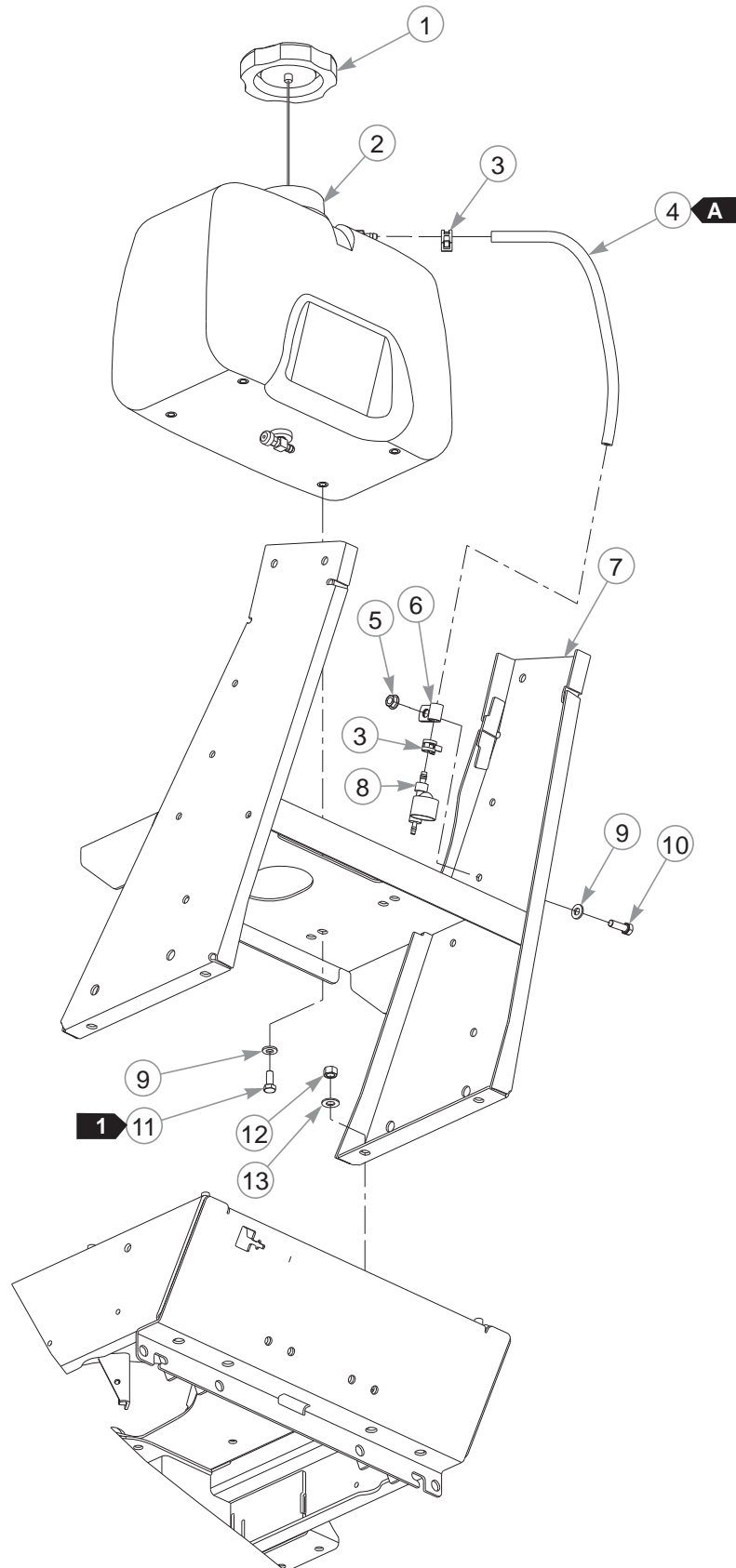

36" Fuel System w/o Carb. Canister—S/N Prior to 12081093

INDEX NO.	PART NO.	QTY.	DESCRIPTION
1	602916	1	FUEL CAP, 3.5"
2	603035	1	FUEL TANK ASSEMBLY
3	000323	2	HOSE CLAMP
4	015818	14"	1/4" FUEL LINE
5	016832	1	NT .312-18 HX FLK ZNYC
6	000398	1	LOOP CLAMP
7	110511	1	CONSOLE SUPPORT
8	603114	1	VACUUM BREAKER
9	768523	5	FW .343 X .687 X .051/.080H
10	036236	1	CS .312-18 X 1.00 HX G5
11	034280	4	CS .312-18 X .75 HX G5
12	054502	4	NT .375-16 HX G5 ZNY
13	767954	4	FW .379 X .813 X .063

NOTES:

LINE LENGTHS		
	14"	TANK TO VACUUM BREAKER (VAPOR)

1. Torque to 7 ft-lbs.

48/54" Fuel Sys. w/o Carb. Canister—S/N 12080674 & Higher

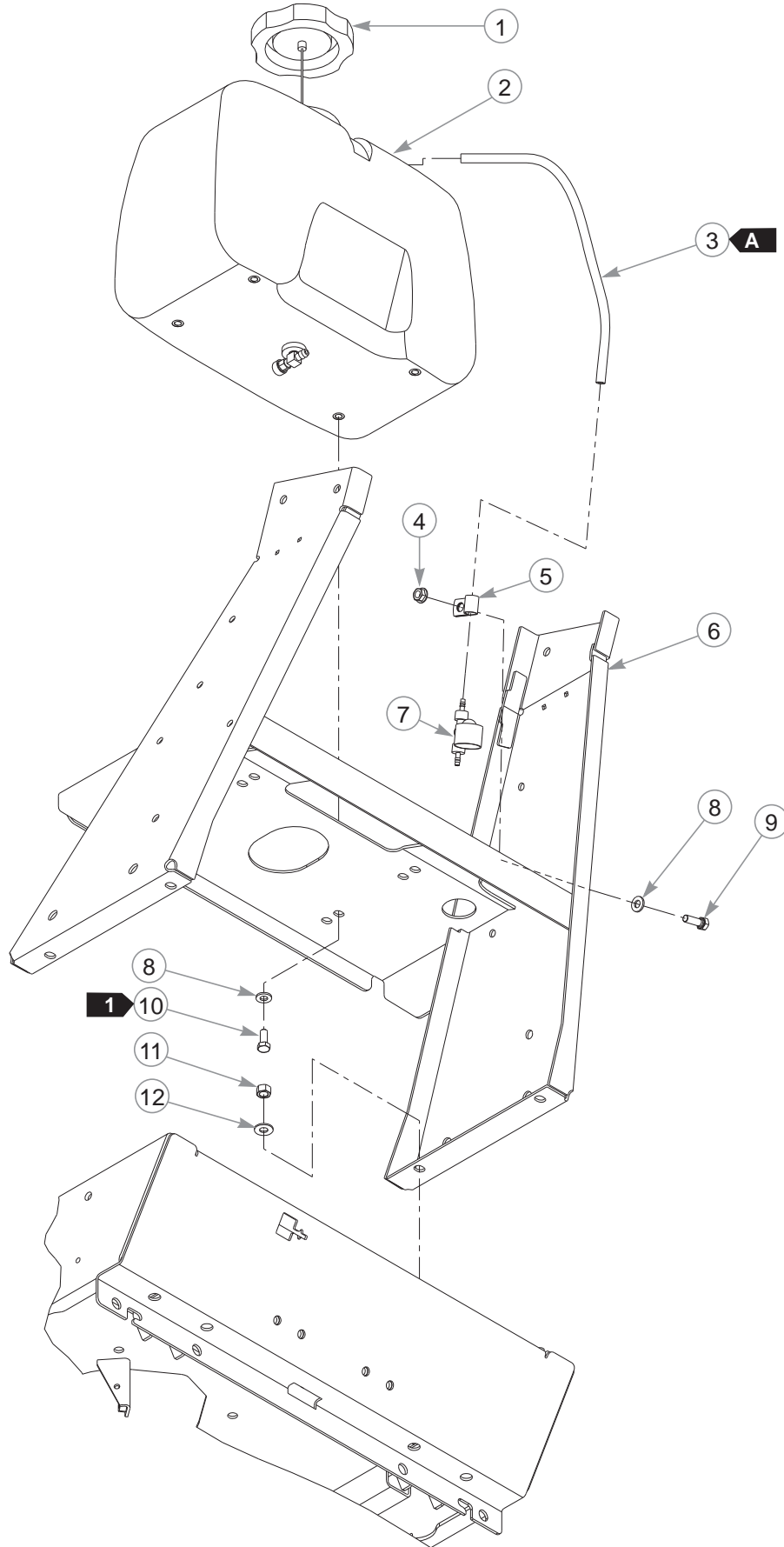

48/54" Fuel Sys. w/o Carb. Canister—S/N 12080674 & Higher

INDEX NO.	PART NO.	QTY.	DESCRIPTION
1	602916	1	RATCHETING GAS CAP, 3.5"
2	605097	1	FUEL TANK ASSEMBLY (S/N 14043531 & HIGHER)
	604056	1	FUEL TANK ASSEMBLY (S/N 12080674–14043530)
3	603326	14"	3/16" VAPOR LINE
4	016832	1	NT .312-18 HX FLK ZNYC
5	000398	1	LOOP CLAMP
6	110602	1	CONSOLE SUPPORT
7	604305	1	VACUUM BREAKER
8	768523	5	FW .343 X .687 X .051/.080H
9	036236	1	CS .312-18 X 1.00 HX G5
10	034280	4	CS .312-18 X .75 HX G5
11	054502	4	NT .375-16 HX G5 ZNY
12	767954	4	FW .379 X .813 X .063

NOTES:

LINE LENGTHS		
A	14"	TANK TO VACUUM BREAKER (VAPOR)

1. Torque to 7 ft-lbs.

48/54" Fuel Sys. w/o Carb. Canister—S/N Prior to 12080674

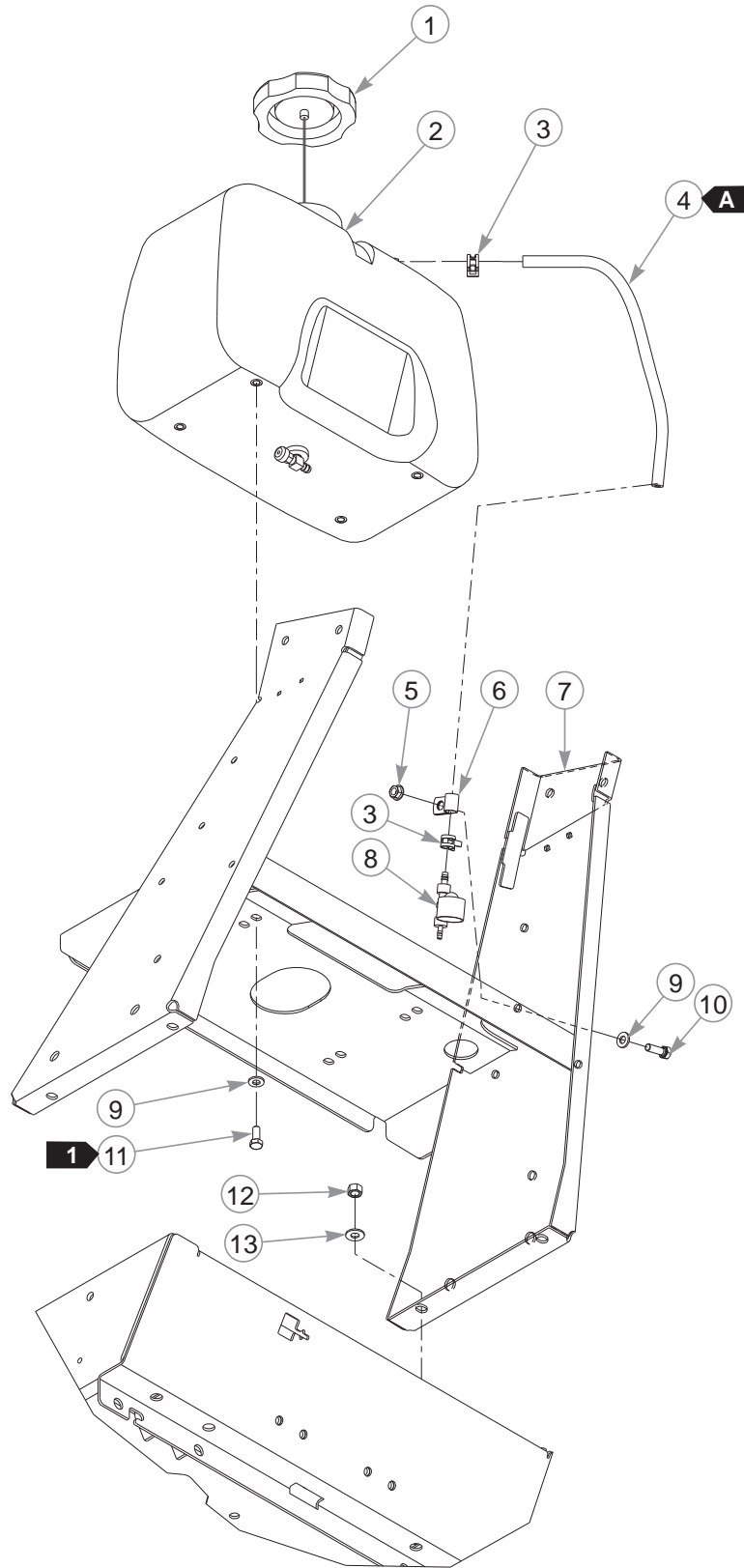

48/54" Fuel Sys. w/o Carb. Canister—S/N Prior to 12080674

INDEX NO.	PART NO.	QTY.	DESCRIPTION
1	602916	1	FUEL CAP, 3.5"
2	603035	1	FUEL TANK ASSEMBLY
3	000323	2	HOSE CLAMP
4	015818	14"	1/4" FUEL LINE
5	016832	1	NT .312-18 HX FLK ZNYC
6	000398	1	LOOP CLAMP
7	110602	1	CONSOLE SUPPORT
8	603114	1	VACUUM BREAKER
9	768523	5	FW .343 X .687 X .051/.080H
10	036236	1	CS .312-18 X 1.00 HX G5
11	034280	4	CS .312-18 X .75 HX G5
12	054502	4	NT .375-16 HX G5 ZNY
13	767954	4	FW .379 X .813 X .063

NOTES:

LINE LENGTHS		
	14"	TANK TO VACUUM BREAKER (VAPOR)

1. Torque to 7 ft-lbs.

Fuel Tank w/o Carbon Canister Service Parts

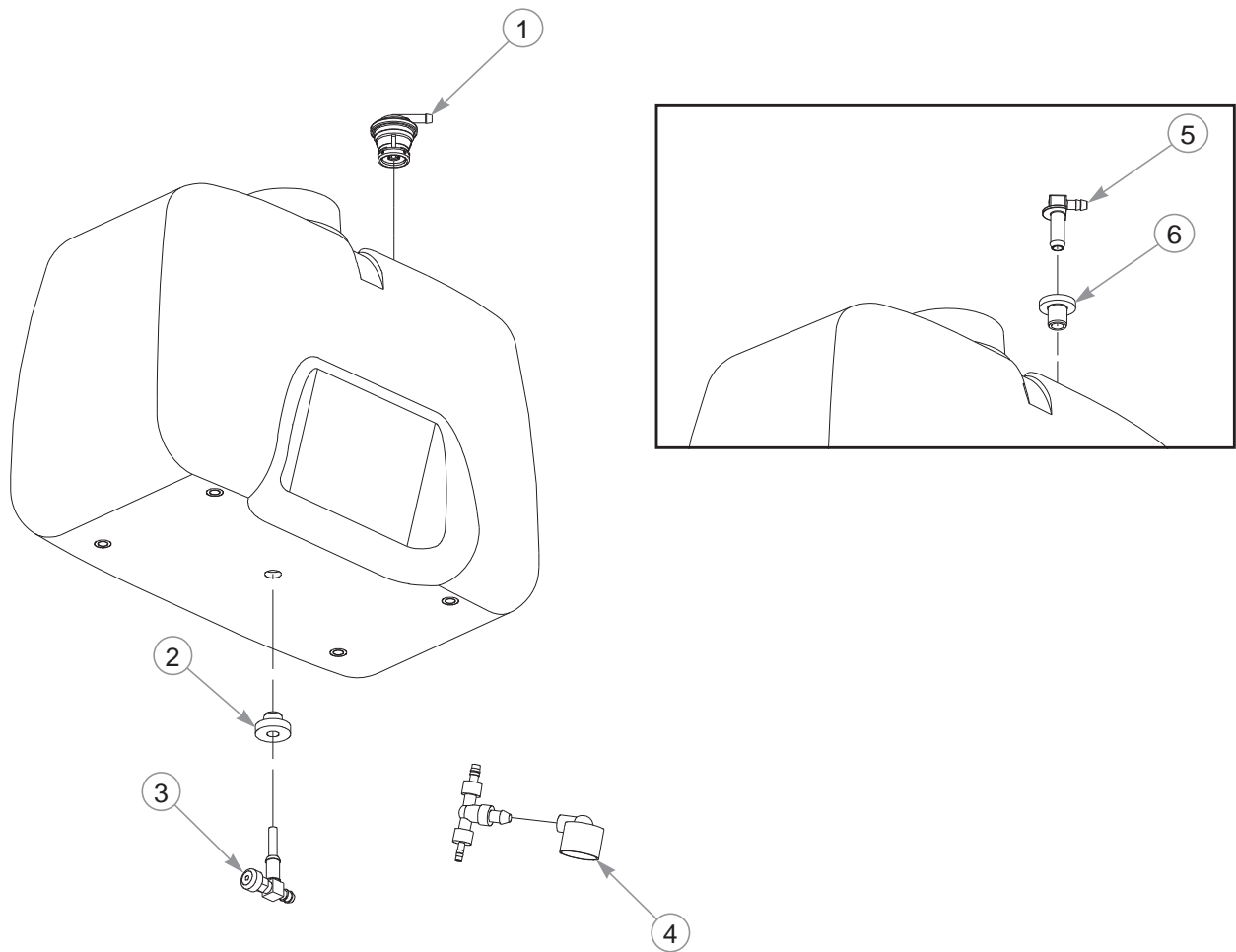

INDEX NO.	PART NO.	QTY.	DESCRIPTION
1	117118	1	VENT FITTING KIT (S/N PRIOR TO 12052597)
2	785295	1	GROMMET
3	783944	1	FUEL SHUT-OFF VALVE
4	603161	1	VACUUM BREAKER FILTER
5	604287	1	VENT FITTING (S/N 12080674 & HIGHER)
	604199	1	FUEL VENT VALVE (S/N 12052597 TO 12080673)
6	604200	1	GROMMET (S/N 12052597 & HIGHER)

NOTES:

This page intentionally left blank.

36" Fuel System with Carb. Canister—S/N 12111102 & Higher

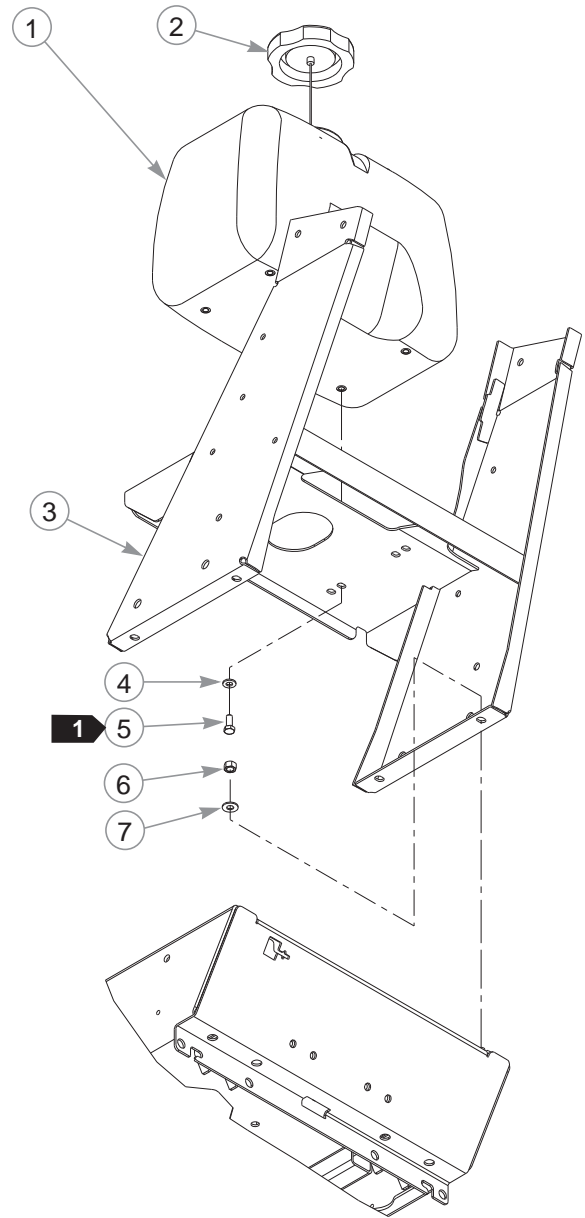
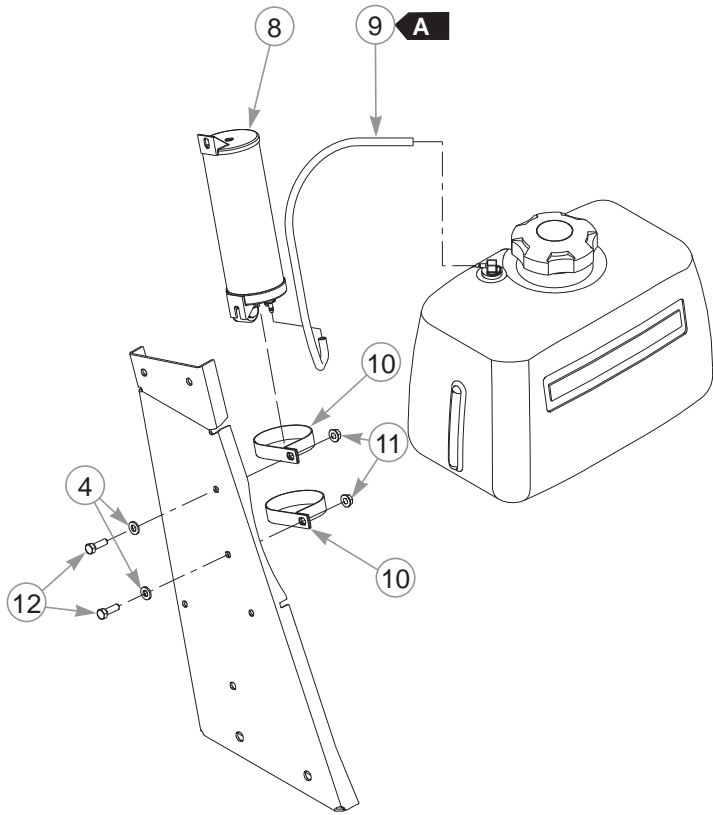

36" Fuel System with Carb. Canister—S/N 12111102 & Higher

INDEX NO.	PART NO.	QTY	DESCRIPTION
1	605097	1	FUEL TANK ASSEMBLY (S/N 14043116 & HIGHER)
	604056	1	FUEL TANK ASSEMBLY (S/N 12111102–14043115)
2	602916	1	RATCHETING GAS CAP, 3.5"
3	110511	1	CONSOLE SUPPORT
4	768523	6	FW .343 X .687 X .051/.080H
5	034280	4	CS .312-18 X .75 HX G5
6	054502	4	NT .375-16 HX G5 ZNY
7	767954	4	FW .379 X .813 X .063
8	604314	1	CARBON CANISTER
9	603326	22"	3/16" VAPOR LINE
10	602980	2	3.0" CUSHIONED CLAMP
11	016832	2	NT .312-18 HX FLK ZNYC
12	036236	2	CS .312-18 X 1.00 HX G5

NOTES:

VAPOR LINE LENGTHS		
	22"	TANK TO CARBON CANISTER (VAPOR)

1. Torque to 7 ft-lbs.

36" Fuel System with Carb. Canister—S/N Prior to 12111102

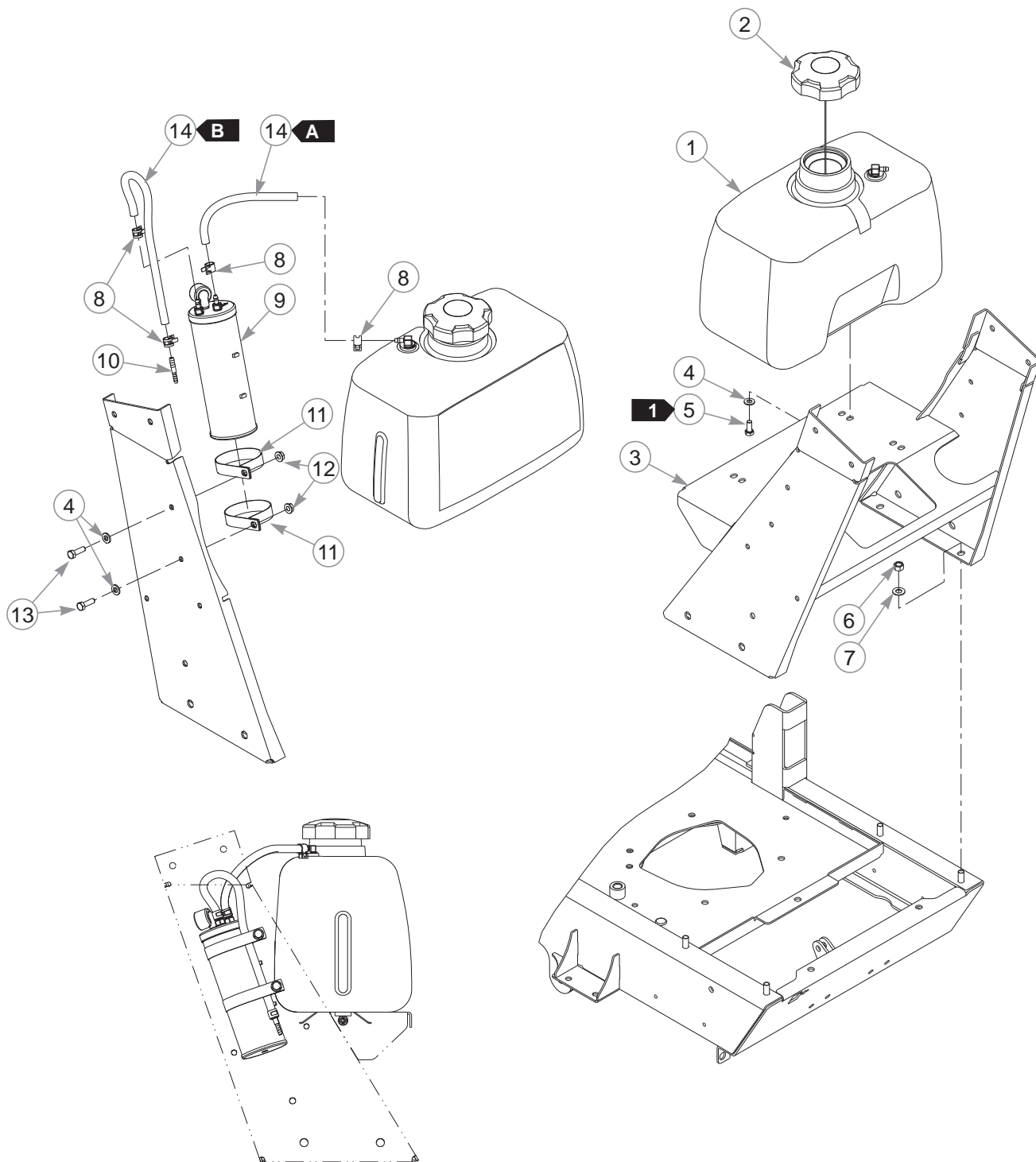

36" Fuel System with Carb. Canister—S/N Prior to 12111102

INDEX NO.	PART NO.	QTY	DESCRIPTION
1	603035	1	FUEL TANK ASSEMBLY
2	602916	1	RATCHETING GAS CAP, 3.5"
3	110511	1	CONSOLE SUPPORT
4	768523	6	FW .343 X .687 X .051/.080H
5	034280	4	CS .312-18 X .75 HX G5
6	054502	4	NT .375-16 HX G5 ZNY
7	767954	4	FW .379 X .813 X .063
8	000323	4	HOSE CLAMP
9	602982	1	CARBON CANISTER
10	603337	1	FTG, -4 BARB/-3 BARB STR
11	602980	2	3.0" CUSHIONED CLAMP
12	016832	2	NT .312-18 HX FLK ZNYC
13	036236	2	CS .312-18 X 1.00 HX G5
14	015818	24"	VAPOR LINE, 1/4"

NOTES:

VAPOR LINE LENGTHS		
A	9"	TANK TO CARBON CANISTER (VAPOR)
B	15"	CARBON CANISTER TO FITTING (VAPOR)

1. Torque to 7 ft-lbs.

48/54" Fuel Sys. w/ Carb. Canister—S/N 12080854 & Higher

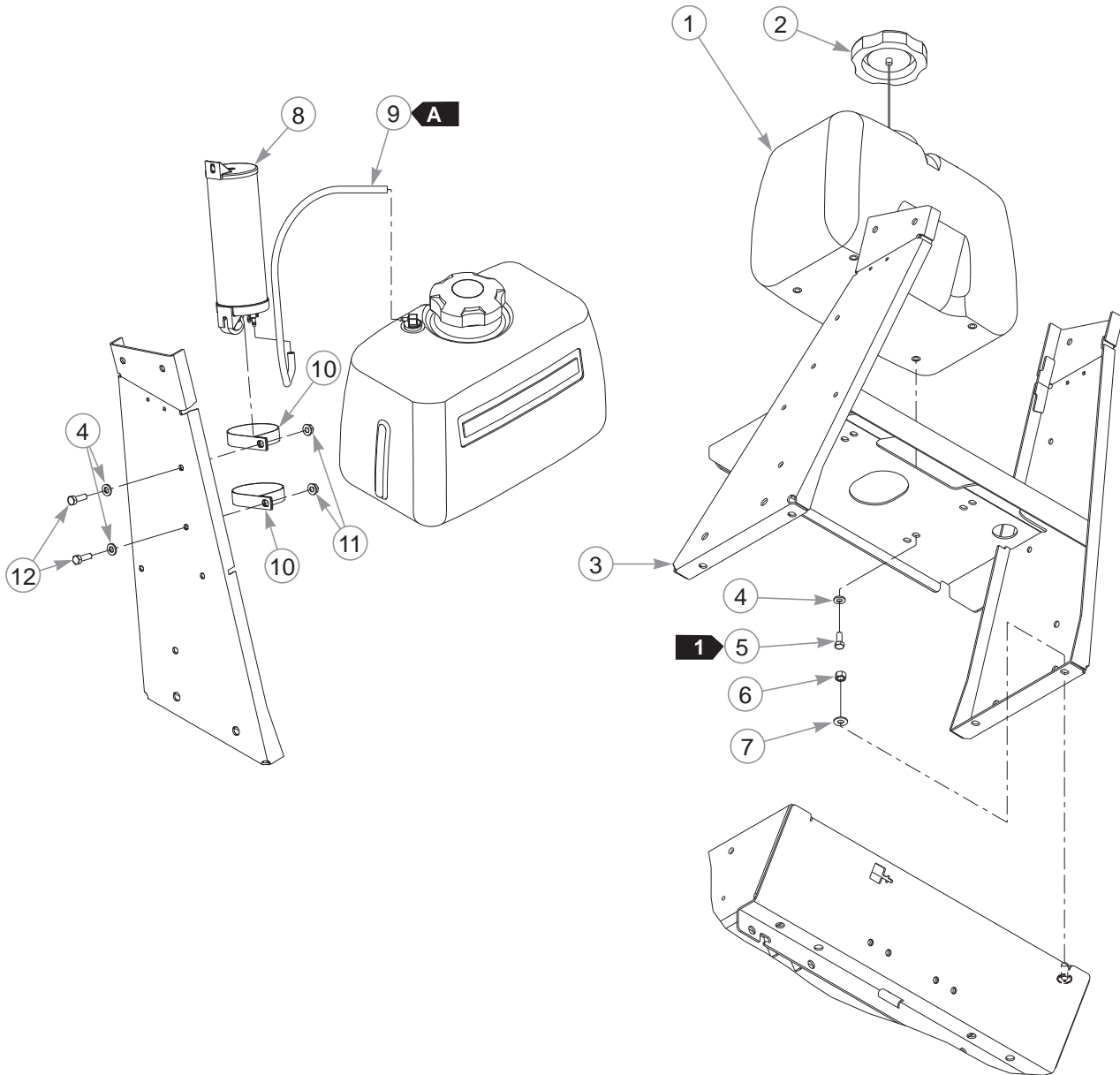

48/54" Fuel Sys. w/ Carb. Canister—S/N 12080854 & Higher

INDEX NO.	PART NO.	QTY	DESCRIPTION
1	605097	1	FUEL TANK ASSEMBLY (S/N 14043116 & HIGHER)
	604056	1	FUEL TANK ASSEMBLY (S/N 12080854–14043115)
2	602916	1	RATCHETING GAS CAP, 3.5"
3	110602	1	CONSOLE SUPPORT
4	768523	6	FW .343 X .687 X .051/.080H
5	034280	4	CS .312-18 X .75 HX G5
6	054502	4	NT .375-16 HX G5 ZNY
7	767954	4	FW .379 X .813 X .063
8	604314	1	CARBON CANISTER
9	603326	22"	3/16" VAPOR LINE
10	602980	2	3.0" CUSHIONED CLAMP
11	016832	2	NT .312-18 HX FLK ZNYC
12	036236	2	CS .312-18 X 1.00 HX G5

NOTES:

VAPOR LINE LENGTHS		
A	22"	TANK TO CARBON CANISTER (VAPOR)

1. Torque to 7 ft-lbs.

48/54" Fuel Sys. w/ Carb. Canister—S/N Prior to 12080854

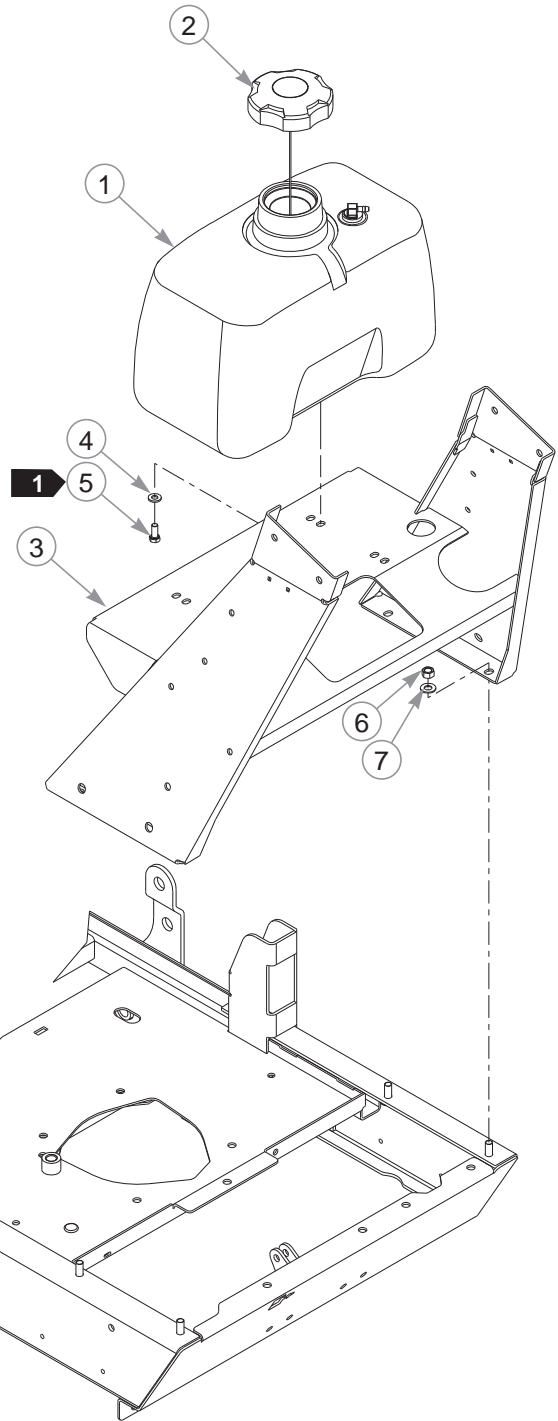
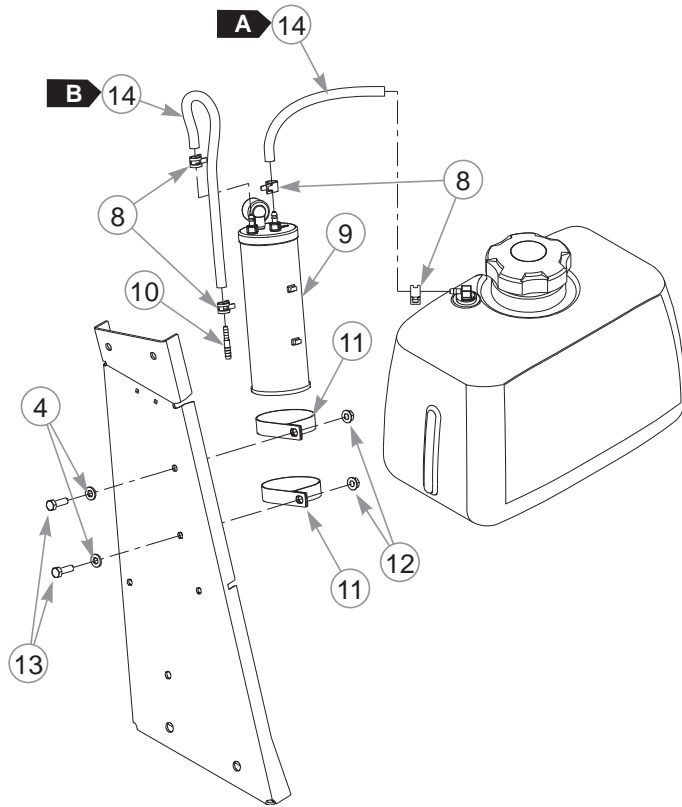

48/54" Fuel Sys. w/ Carb. Canister—S/N Prior to 12080854

INDEX NO.	PART NO.	QTY.	DESCRIPTION
1	603035	1	FUEL TANK ASSEMBLY
2	602916	1	RATCHETING GAS CAP 3.5"
3	110602	1	CONSOLE SUPPORT
4	768523	6	FW .343 X .687 X .051/.080H
5	034280	4	CS .312-18 X .75 HX G5
6	054502	4	NT .375-16 HX G5 ZNY
7	767954	4	FW .379 X .813 X .063
8	000323	4	HOSE CLAMP
9	602982	1	CARBON CANISTER
10	603337	1	FTG, -4 BARB/-3 BARB STR
11	602980	2	3.0" CUSHIONED CLAMP
12	016832	2	NT .312-18 HX FLK ZNYC
13	036236	2	CS .312-18 X 1.00 HX G5
14	015818	24"	1/4" FUEL LINE

NOTES:

VAPOR LINE LENGTHS		
A	9"	TANK TO CARBON CANISTER (VAPOR)
B	15"	CARBON CANISTER TO FITTING (VAPOR)

1. Torque to 7 ft-lbs.

Fuel Tank With Carbon Canister Service Parts

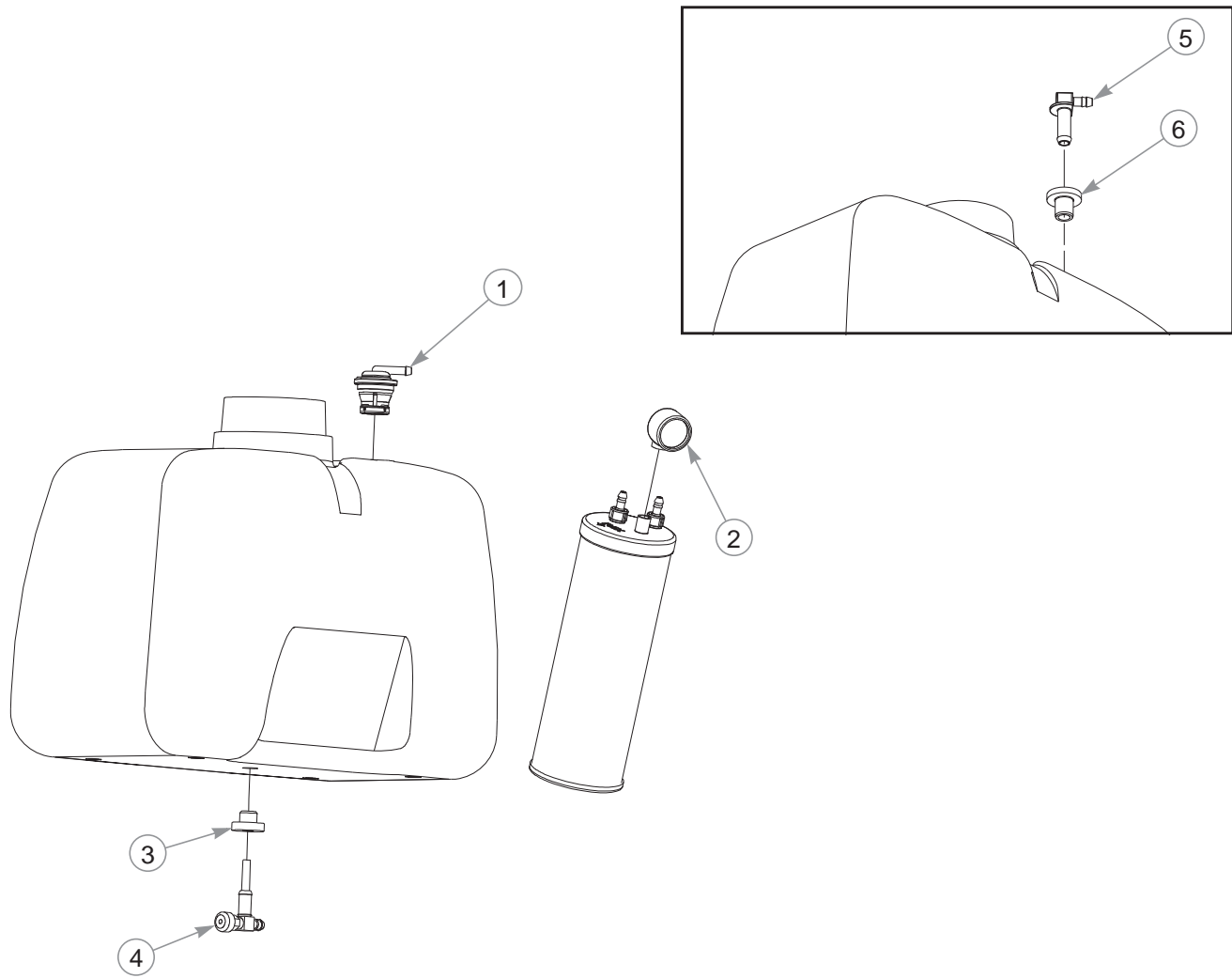

INDEX NO.	PART NO.	QTY.	DESCRIPTION
1	117118	1	VENT FITTING KIT (S/N PRIOR TO 12052597)
2	603161	1	VACUUM BREAKER FILTER
3	785295	1	GROMMET
4	783944	1	FUEL SHUT-OFF VALVE
5	604199	1	FUEL VENT VALVE (S/N 12052597 TO 12080673)
	604287	1	VENT FITTING (S/N 12080674 & HIGHER)
6	604200	1	GROMMET (S/N 12052597 & HIGHER)

NOTES:

Section 6

36" Service Deck	6-2
36" Deck Pulleys & Spindles	6-4
36" Deck	6-6
36" Deck Lift	6-8
36" Deck Mounting Hardware	6-10
48" Service Deck	6-12
48" Deck Pulleys & Spindles	6-14
48" Deck	6-16
54" Service Deck	6-18
54" Deck Pulleys & Spindles	6-20
54" Deck	6-22
48" & 54" Deck Lift	6-24
48" & 54" Deck Mounting Hardware	6-26
Spindle Service Parts	6-28

36" Service Deck

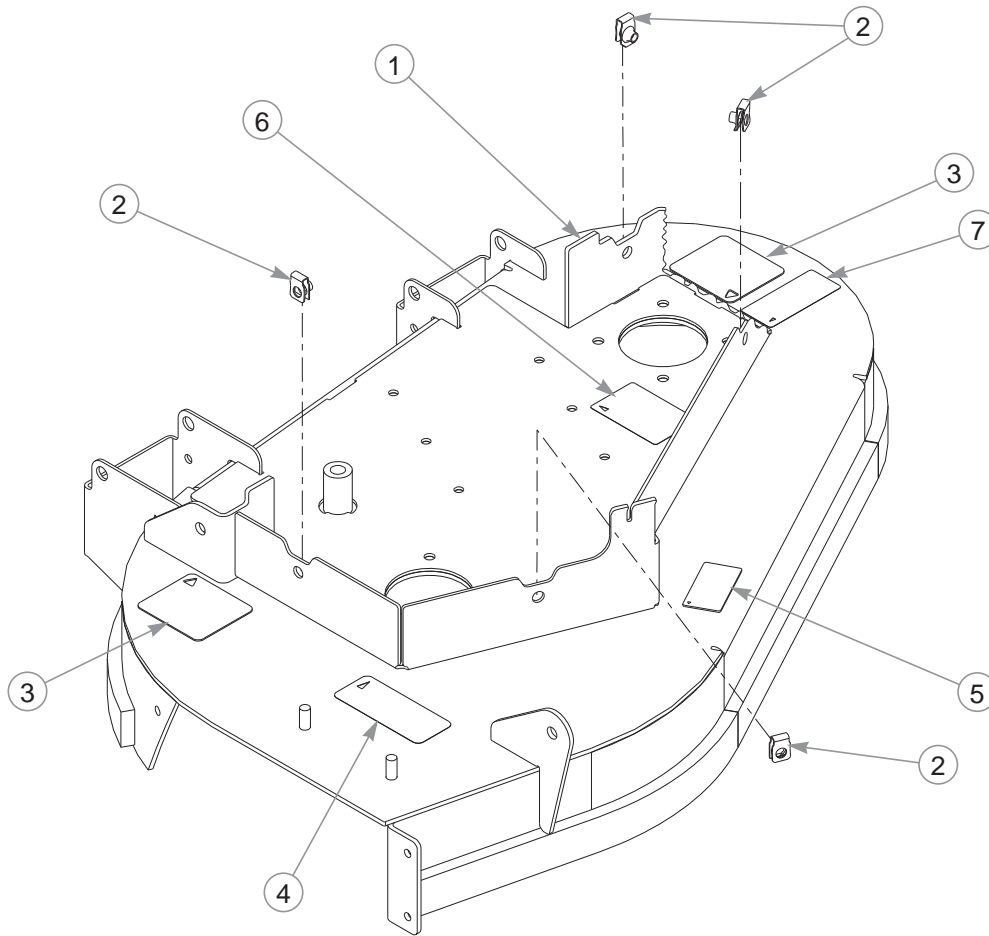

INDEX NO.	PART NO.	QTY.	DESCRIPTION
1	550229	1	36" DECK (WITH HARDWARE & DECALS)
2	601069	4	CN .312-18 X .20 MAX THK
3	601787	2	DECK DANGERS DECAL
4	601796	1	DISCHARGE CHUTE DECAL
5	793513	1	36" DECK ID DECAL
6	602243	1	BELT ROUTING DECAL
7	601931	1	THROWN OBJECTS DECAL

NOTES:

This page intentionally left blank.

36" Deck Pulleys & Spindles

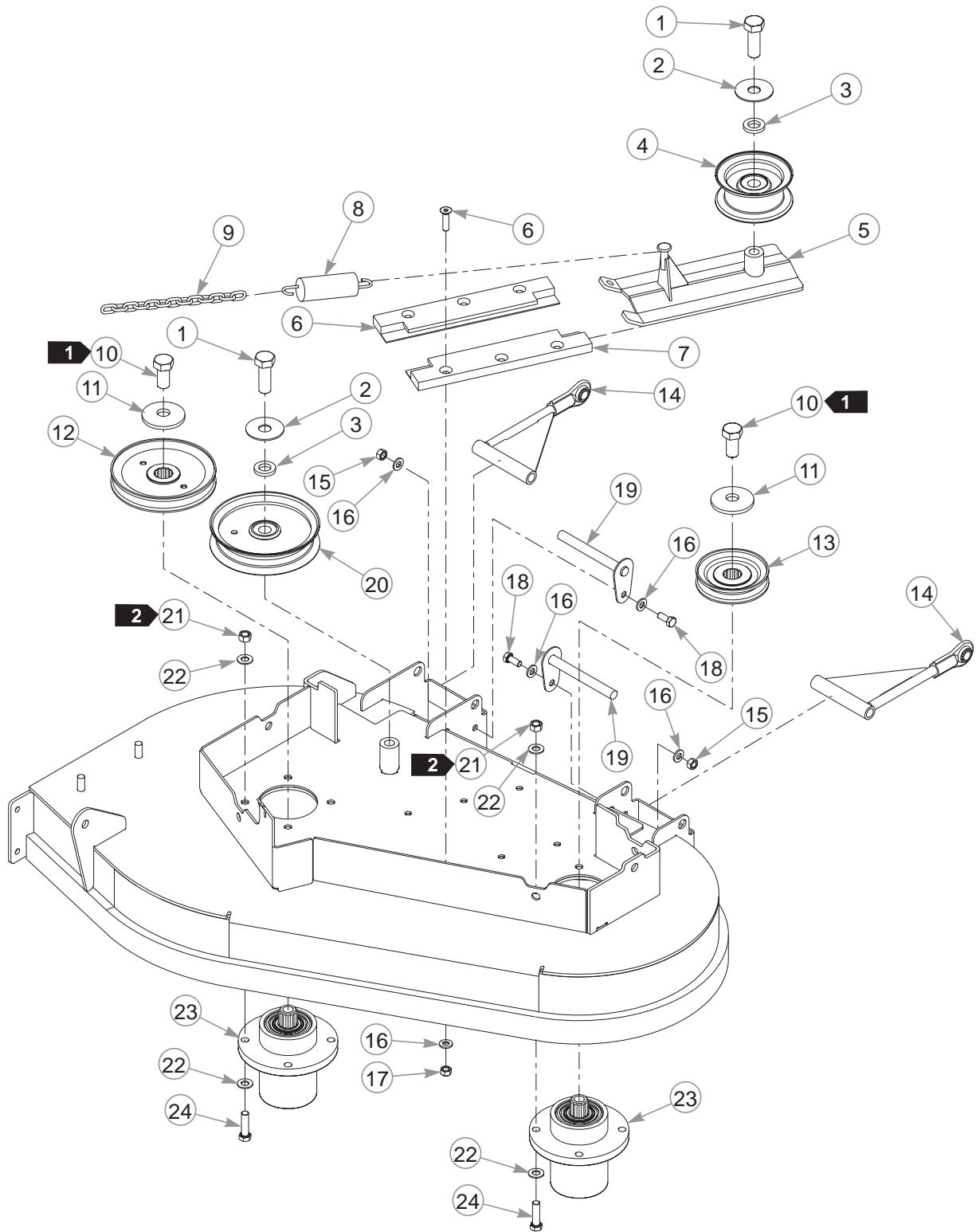

36" Deck Pulleys & Spindles

INDEX NO.	PART NO.	QTY.	DESCRIPTION
1	025007	2	CS .625-11 X 1.75 HX G5
2	046821	2	FW .656 X 2.00 X .078 ZNYC
3	797449	2	FW .650 X 1.125 X .18 ZNYC G5
4	601162	1	IDLER PULLEY
5	105031	1	DECK IDLER
6	784199	6	CS .312-18 X 1.25 FLT SH
7	601434	2	UHMW IDLER SLIDE
8	036384	1	SPRING 1/4 COIL PL 1.23
9	259812	1	CHAIN
10	781872	2	CS .625-11 X 1.25 HX G5 Z
11	782474	2	CW .631 X 2.25 X .187 PNT
12	796656	1	PULLEY 5.62 EOD, A-SEC
13	796664	1	PULLEY 3.75 EOD, A-SEC
14	330225	2	PULLBAR
15	034272	2	NT .312-18 HX G5
16	768523	10	FW .343 X .687 X .051/.080H
17	058776	6	NT .312-18 HX G5 ZY NL
18	034280	2	CS .312-18 X .75 HX G5
19	322974	2	PULLBAR PIN
20	781856	1	IDLER PULLEY NHI 5.0"
21	054502	8	NT .375-16 HX G5 ZNY
22	767954	16	FW .379 X .813 X .063
23	783506	2	BLADE SPINDLE
24	005116	8	CS .375-16 X 1.375 HX G5

NOTES:

1. Torque to 118 ft-lbs.
2. Torque to 30 ft-lbs.

36" Deck

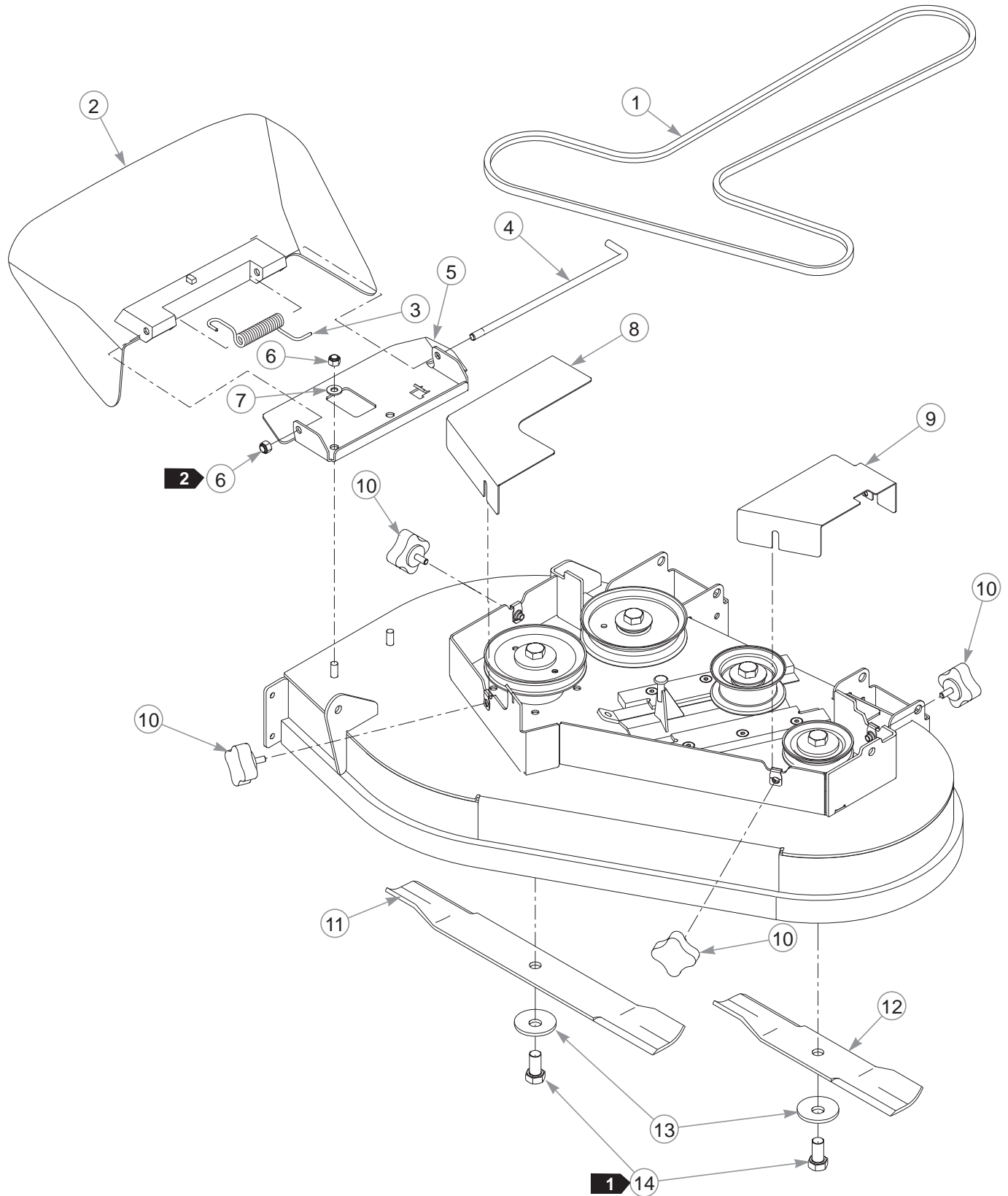

36" Deck

INDEX NO.	PART NO.	QTY.	DESCRIPTION
1	601786	1	BELT, A 89.50 EL
2	601806	1	DISCHARGE CHUTE
3	601824	1	TORSION SPRING
4	601843	1	CHUTE PIN
5	114793	1	CHUTE BRACKET
6	086660	3	NT .375-16 HX G5 NL
7	767954	2	FW .379 X .813 X .063
8	110729	1	RS PULLEY COVER
9	110728	1	LS PULLEY COVER
10	792002	4	KNOB 5/16-18 X 3/4"
11	600901	1	BLADE, F20.50"-L-F-CW
	602698	1	BLADE, F20.50"-MUL-F-CW
12	600900	1	BLADE, F13.75"-L-F-CW
	794206	1	BLADE, 13.75"-MUL-F-CW
13	782474	2	CW .631 X 2.25 X .187 PNT
14	781872	2	CS .625-11 X 1.25 HX G5 Z

NOTES:

1. Torque to 118 ft-lbs.
2. Do not torque; the discharge chute must pivot freely.

36" Deck Lift

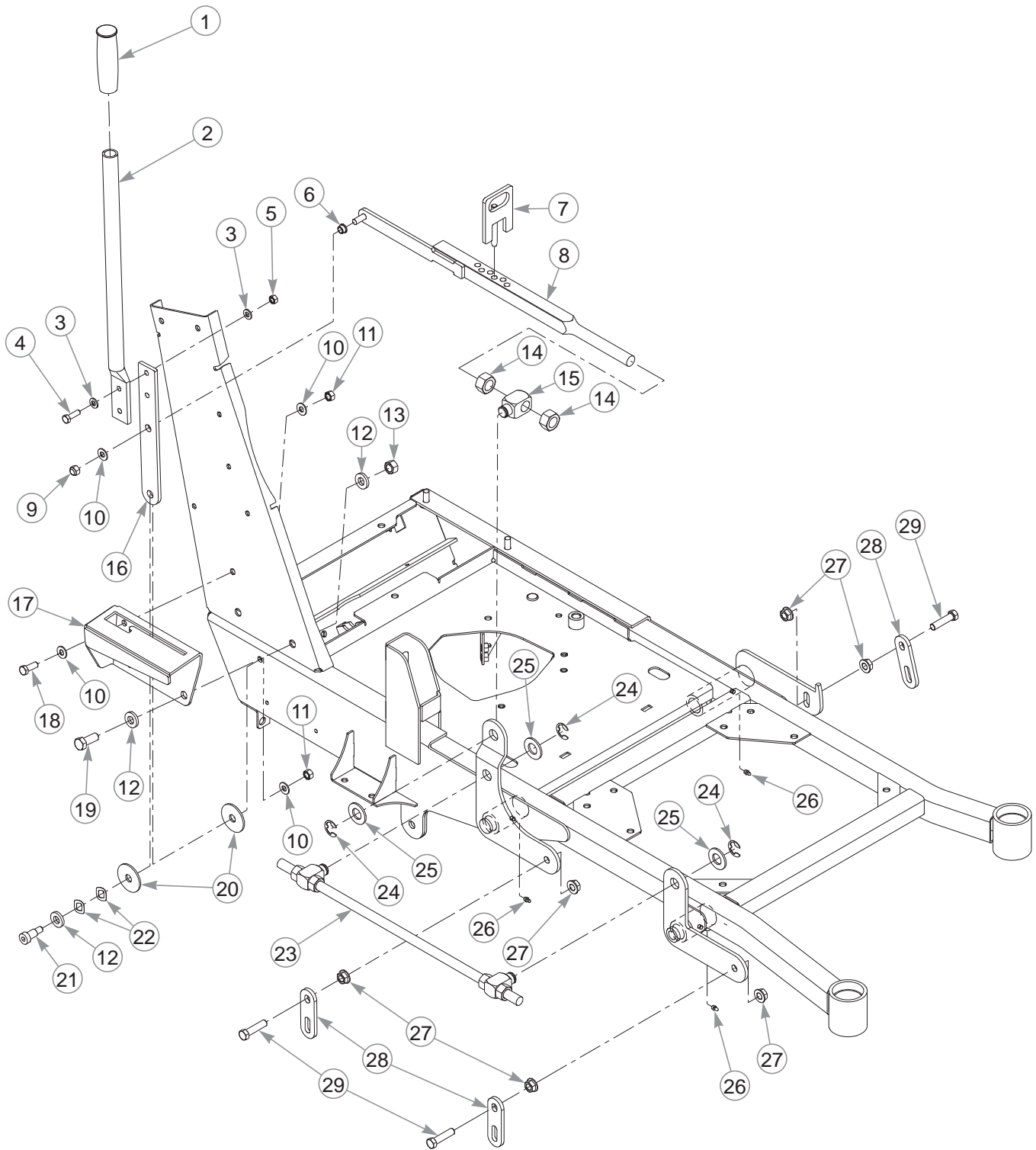

36" Deck Lift

INDEX NO.	PART NO.	QTY.	DESCRIPTION
1	792317	1	GRIP
2	110570	1	DECK LIFT HANDLE
3	768523	4	FW .343 X .687 X .051/.080H
4	036236	2	CS .312-18 X 1.00 HX G5
5	034272	2	NT .312-18 HX G5
6	765339	1	BUSHING
7	348284	1	HEIGHT ADJ STOP
8	110529	1	DECK INDICATOR
9	086660	1	NT .375-16 HX G5 NL
10	767954	4	FW .379 X .813 X .063
11	054502	2	NT .375-16 HX G5
12	767962	11	FW .531 X 1.063 X .175
13	008193	2	NT .500-13 HX G5 ZNYC
14	008417	2	NT .750-10 HX G5 ZNYC
15	781930	1	DECK LIFT MT BLOCK
16	110530	1	LOWER HANDLE
17	550073	1	DECK LIFT COVER (WITH DECAL)
18	036244	1	CS .375-16 X 1.00 HX G5
19	705954	2	CS .500-13 X 1.25 HX G5
20	263517	2	BEARING DISC
21	728550	1	SB .50 X .75SH .375-16TD
22	601953	2	WASHER, WAVY .558 X 1.005
23	601942	1	DECK LIFT ROD NO SPRING
24	781294	3	E CLIP 1.00 X .625 X .05
25	601681	3	FW .781 X 1.50 X .120 ZNYC
26	015495	3	GREASE FITTING STRAIGHT
27	704643	12	NT .437-14 HX FLG ZN
28	110880	3	DECK LIFT LINK
29	055749	6	CS .437-14 X 1.75 HX G5

NOTES:

36" Deck Mounting Hardware

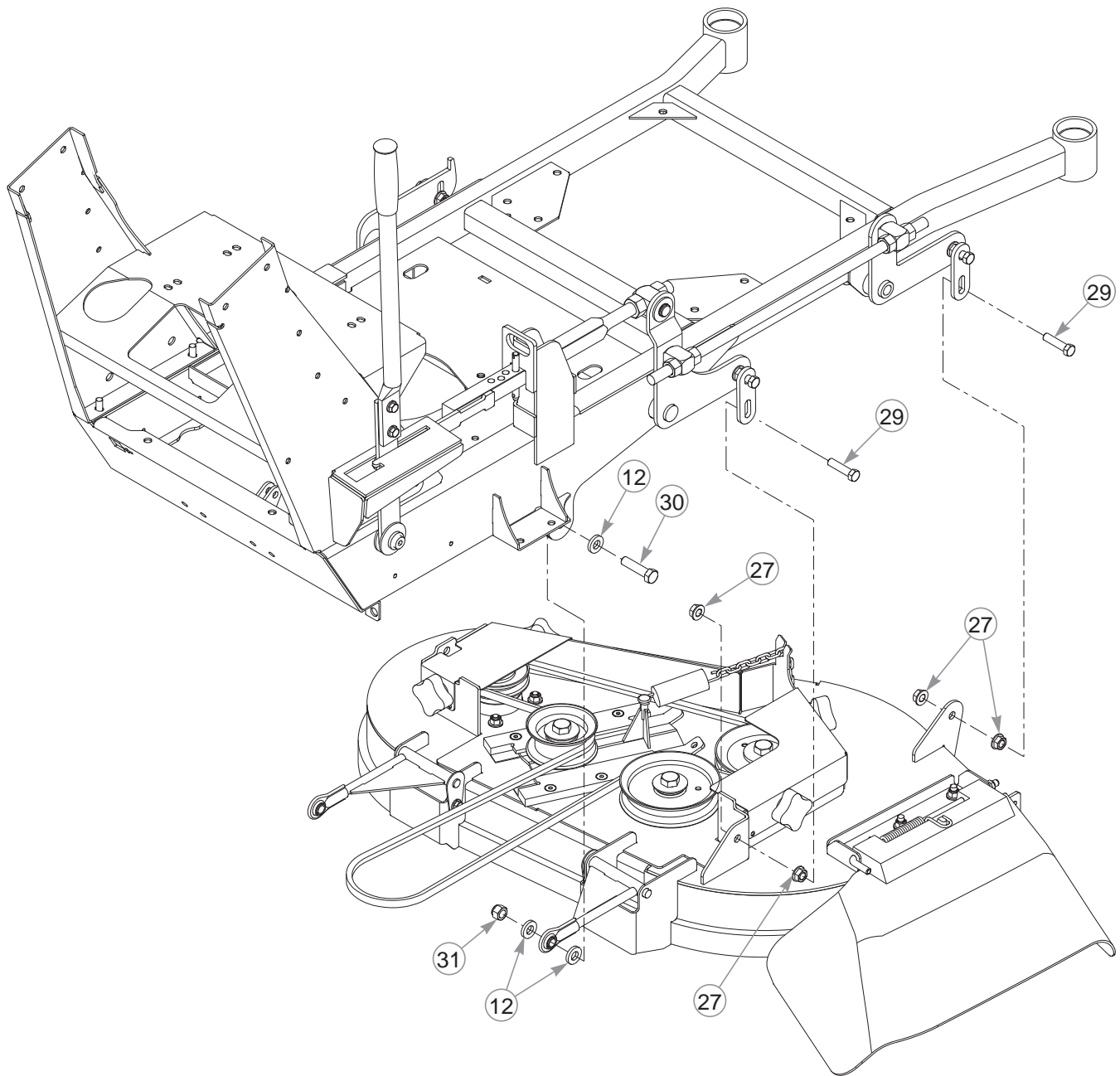

INDEX NO.	PART NO.	QTY.	DESCRIPTION
30	078949	2	CS .500-13 X 2.00 HX G5 ZNY
31	781567	2	NT .500-13 HX G8 ZY NL

NOTES:

This page intentionally left blank.

48" Service Deck

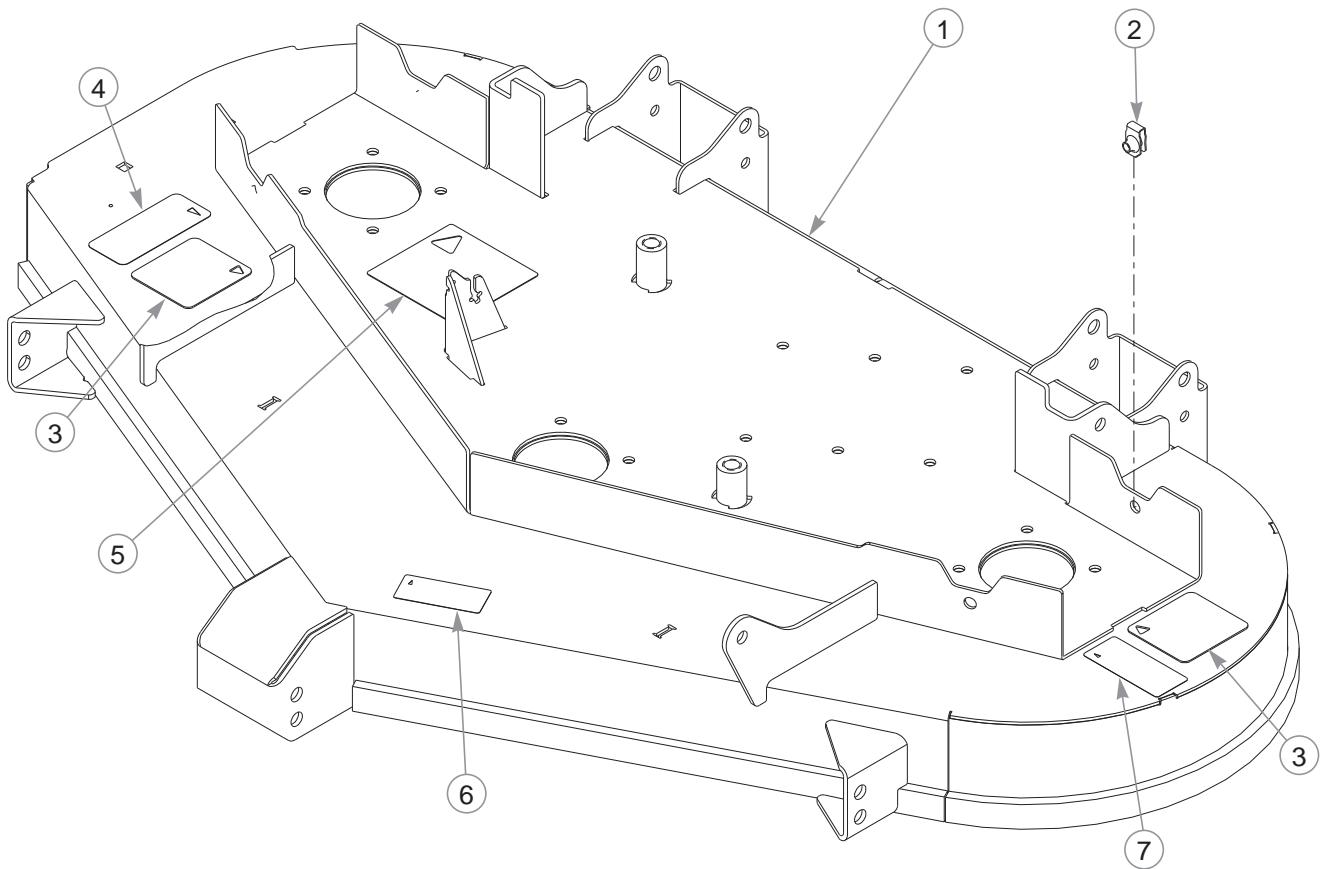

INDEX NO.	PART NO.	QTY.	DESCRIPTION
1	550230	1	48" DECK (WITH HARDWARE & DECALS)
2	601069	4	CN .312-18 X .20 MAX THK
3	601787	2	DECK DANGERS DECAL
4	601796	1	DISCHARGE CHUTE DECAL
5	781419	1	BELT ROUTING DECAL
6	793976	1	48" DECK ID DECAL
7	601931	1	THROWN OBJECTS DECAL

NOTES:

This page intentionally left blank.

48" Deck Pulleys & Spindles

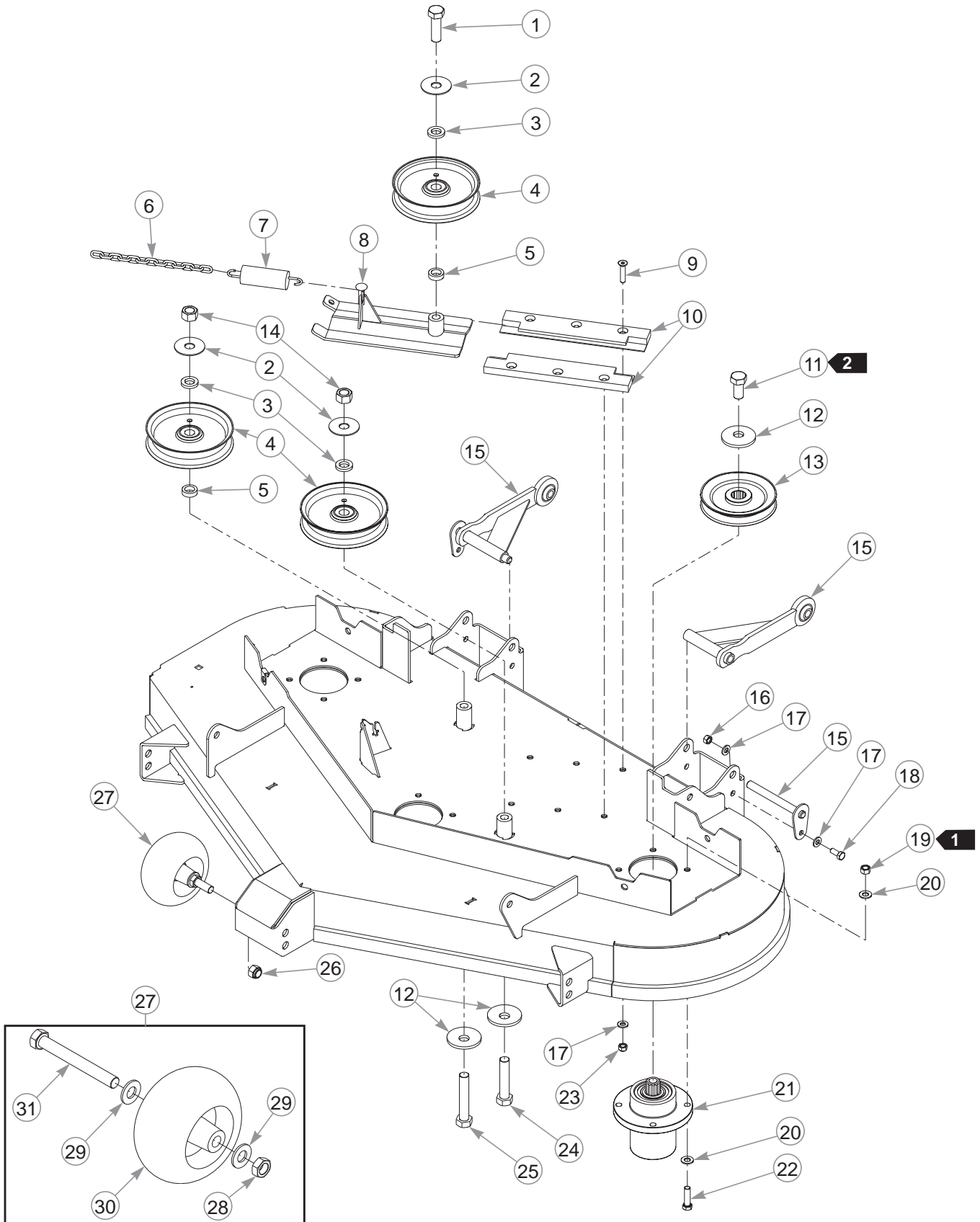

48" Deck Pulleys & Spindles

INDEX NO.	PART NO.	QTY.	DESCRIPTION
1	025007	1	CS .625-11 X 1.75 HX G5
2	046821	3	FW .656 X 2.00 X .078 ZNYC
3	797449	3	FW .650 X 1.125 X .18 ZNYC G5
4	781856	3	IDLER PULLEY NHI 5.0"
5	600296	2	DECK IDLER SPACER
6	259812	1	CHAIN, 13 LINK
7	036384	1	SPRING 1/4 COIL PL 1.23
8	105031	1	DECK IDLER
9	797910	6	CS .312-18 X 1.50 FLT SH ZY
10	601434	2	UHMW IDLER SLIDE
11	781872	3	CS .625-11 X 1.25 HX G5 Z
12	782474	5	CW .631 X 2.25 X .187 PNT
13	792689	3	DRIVE PULLEY 5.19 OP
14	016972	2	NT .625-11 HX G5 ZNYC
15	116335	2	PUSHER ARM
16	034272	2	NT .312-18 HX G5
17	768523	10	FW .343 X .687 X .051/.080H
18	034280	2	CS .312-18 X .75 HX G5
19	054502	12	NT .375-16 HX G5 ZNY
20	767954	24	FW .379 X .813 X .063
21	783506	3	BLADE SPINDLE
22	005116	12	CS .375-16 X 1.375 HX G5
23	058776	6	NT .312-18 HX G5 ZY NL
24	783738	1	CS .625-11 X 3.00 FULL HX G5
25	794875	1	CS .625-11 X 3.50 FLTHD HX G5
26	781567	4	NT .500-13 HX G8 ZY NL
27	788166	4	PLASTIC WHEEL ASSEMBLY (INCLUDES HARDWARE)
28	053199	4	NT .500-13 HX JAM ZNYC
29	767962	8	FW .531 X 1.063 X .175
30	031997	4	PLASTIC WHEEL
31	781708	4	CS .500-13 X 4.25 HX G5

NOTES:

1. Torque to 30 ft-lbs.
2. Torque to 118 ft-lbs.

48" Deck

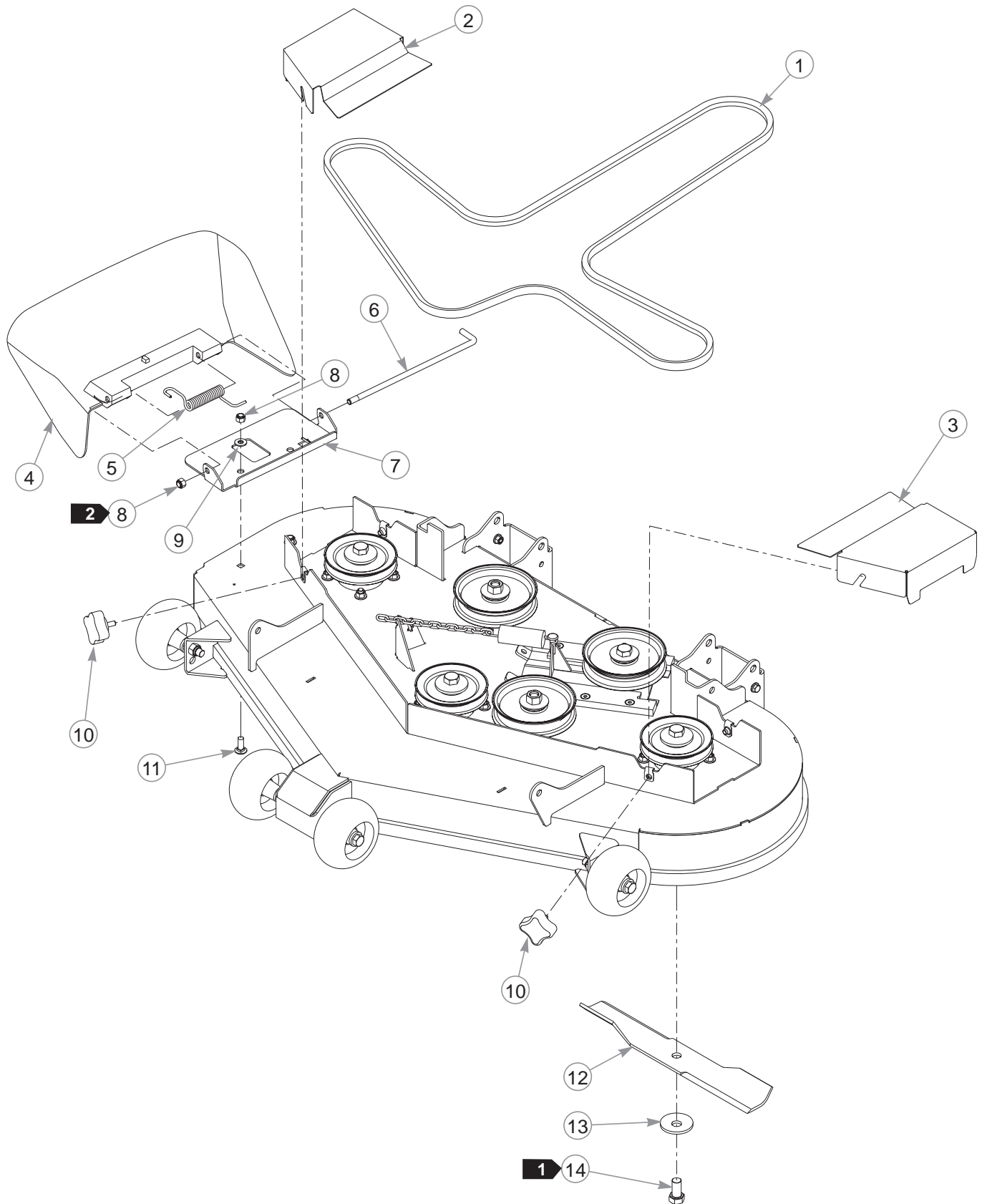

48" Deck

INDEX NO.	PART NO.	QTY.	DESCRIPTION
1	601969	1	BELT, B 122.00 EL
2	108149	1	RS PULLEY COVER
3	108148	1	LS PULLEY COVER
4	601806	1	DISCHARGE CHUTE
5	601824	1	TORSION SPRING
6	601843	1	CHUTE PIN
7	114794	1	CHUTE MOUNT
8	086660	3	NT .375-16 HX G5 NL
9	767954	2	FW .379 X .813 X .063
10	792002	4	KNOB 5/16-18 X 3/4"
11	025395	2	CB .375-16 X 1.00 G5 ZNY
12	795757	3	BLADE, F16.50"-H-F-CW
	796623	3	BLADE, 16.50"-MUL-F-CW
	796631	3	BLADE, 16.50"-GAT-F-CW
13	782474	3	CW .631 X 2.25 X .187 PNT
14	781872	3	CS .625-11 X 1.25 HX G5 Z

NOTES:

1. Torque to 118 ft-lbs.
2. Do not torque; the discharge chute must pivot freely.

54" Service Deck

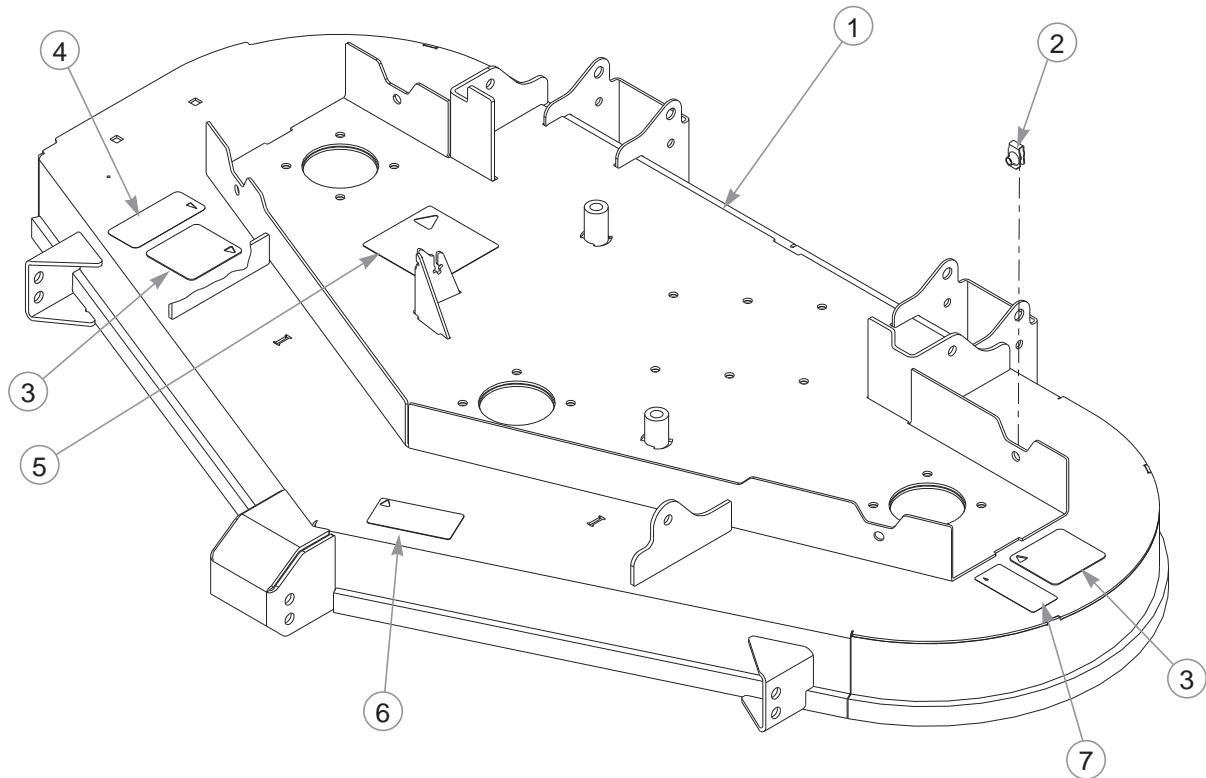

INDEX NO.	PART NO.	QTY.	DESCRIPTION
1	550231	1	54" DECK (WITH HARDWARE & DECALS)
2	601069	4	CN .312-18 X .20 MAX THK
3	601787	2	DECK DANGERS DECAL
4	601796	1	DISCHARGE CHUTE DECAL
5	781419	1	BELT ROUTING DECAL
6	799171	1	54" DECK ID DECAL
7	601931	1	THROWN OBJECTS DECAL

NOTES:

This page intentionally left blank.

54" Deck Pulleys & Spindles

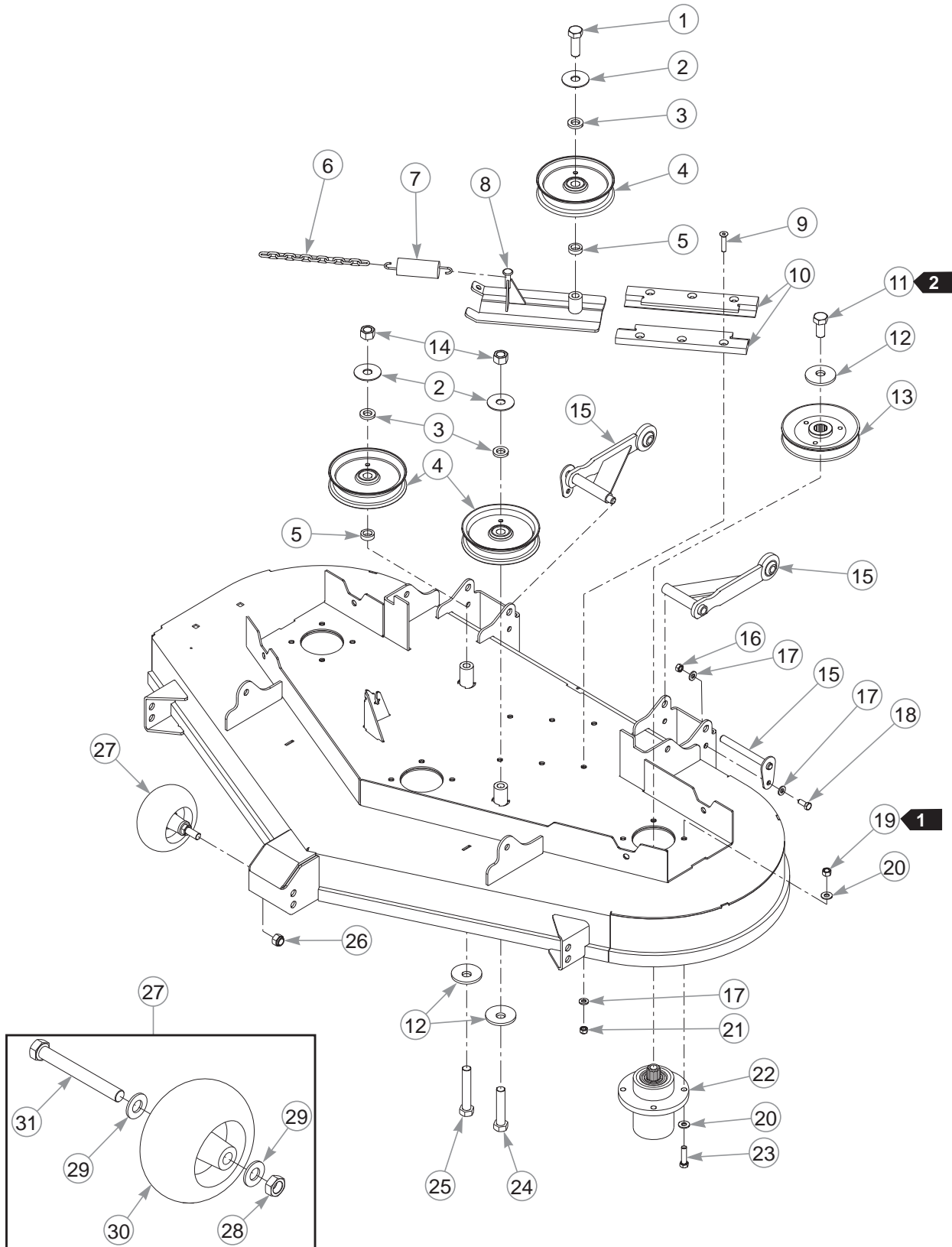

54" Deck Pulleys & Spindles

INDEX NO.	PART NO.	QTY.	DESCRIPTION
1	025007	1	CS .625-11 X 1.75 HX G5
2	046821	3	FW .656 X 2.00 X .078 ZNYC
3	797449	3	FW .650 X 1.125 X .18 ZNYC
4	781856	3	IDLER PULLEY NHI 5.0"
5	600296	2	DECK IDLER SPACER
6	259812	1	CHAIN, 13 LINK
7	036384	1	SPRING 1/4 COIL PL 1.23
8	105031	1	DECK IDLER
9	797910	6	CS .312-18 X 1.50 FLT SH ZY
10	601434	2	UHMW IDLER SLIDE
11	781872	3	CS .625-11 X 1.25 HX G5 Z
12	782474	5	CW .631 X 2.25 X .187 PNT
13	786889	3	DRIVE PULLEY 5.68 OP
14	016972	2	NT .625-11 HX G5 ZNYC
15	116335	2	PUSHER ARM
16	034272	2	NT .312-18 HX G5
17	768523	10	FW .343 X .687 X .051/.080H
18	034280	2	CS .312-18 X .75 HX G5
19	054502	12	NT .375-16 HX G5 ZNY
20	767954	24	FW .379 X .813 X .063
21	058776	6	NT .312-18 HX G5 ZY NL
22	783506	3	BLADE SPINDLE
23	005116	12	CS .375-16 X 1.375 HX G5
24	783738	1	CS .625-11 X 3.00 FULL HX G5
25	794875	1	CS .625-11 X 3.50 FLTHD HX G5
26	781567	4	NT .500-13 HX G8 ZY NL
27	788166	4	PLASTIC WHEEL ASSEMBLY (INCLUDES HARDWARE)
28	053199	4	NT .500-13 HX JAM ZNYC
29	767962	8	FW .531 X 1.063 X .175
30	031997	4	PLASTIC WHEEL
31	781708	4	CS .500-13 X 4.25 HX G5

NOTES:

1. Torque to 30 ft-lbs.
2. Torque to 118 ft-lbs.

54" Deck

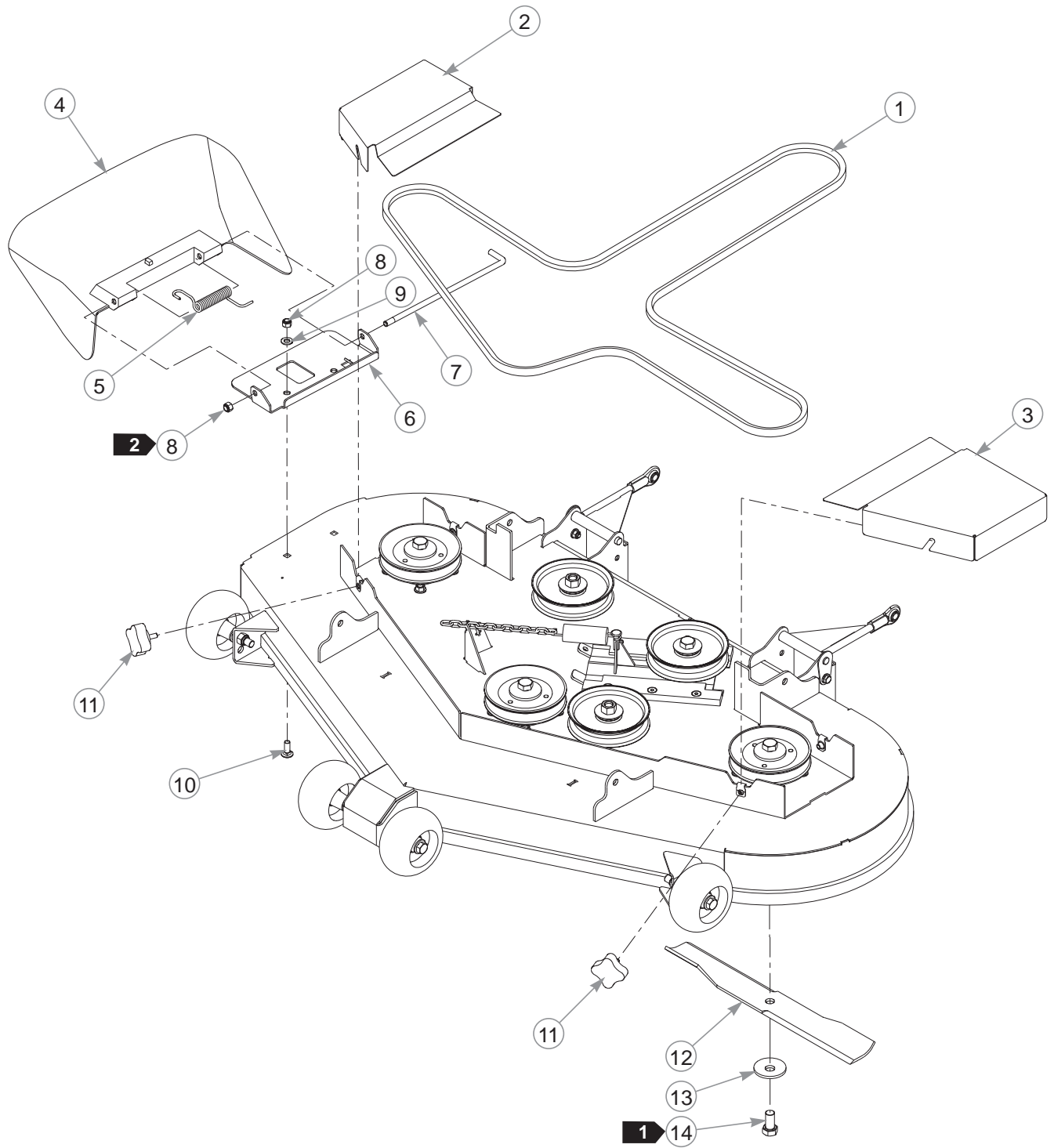

54" Deck

INDEX NO.	PART NO.	QTY.	DESCRIPTION
1	601788	1	BELT, B 133.10 EL
2	108124	1	RS PULLEY COVER
3	108123	1	LS PULLEY COVER
4	601806	1	DISCHARGE CHUTE
5	601824	1	TORSION SPRING
6	114794	1	CHUTE MOUNT
7	601843	1	CHUTE PIN
8	086660	3	NT .375-16 HX G5 NL
9	767954	2	FW .379 X .813 X .063
10	025395	2	CB .375-16 X 1.00 G5 ZNY
11	792002	4	KNOB 5/16-18 X 3/4"
12	797696	3	BLADE, F18.50"-H-F-CW
	797704	3	BLADE, 18.50"-MUL-F-CW
	797712	3	BLADE, 18.50"-GAT-F-CW
13	782474	3	CW .631 X 2.25 X .187 PNT
14	781872	3	CS .625-11 X 1.25 HX G5 Z

NOTES:

1. Torque to 118 ft-lbs.
2. Do not torque; the discharge chute must pivot freely.

48" & 54" Deck Lift

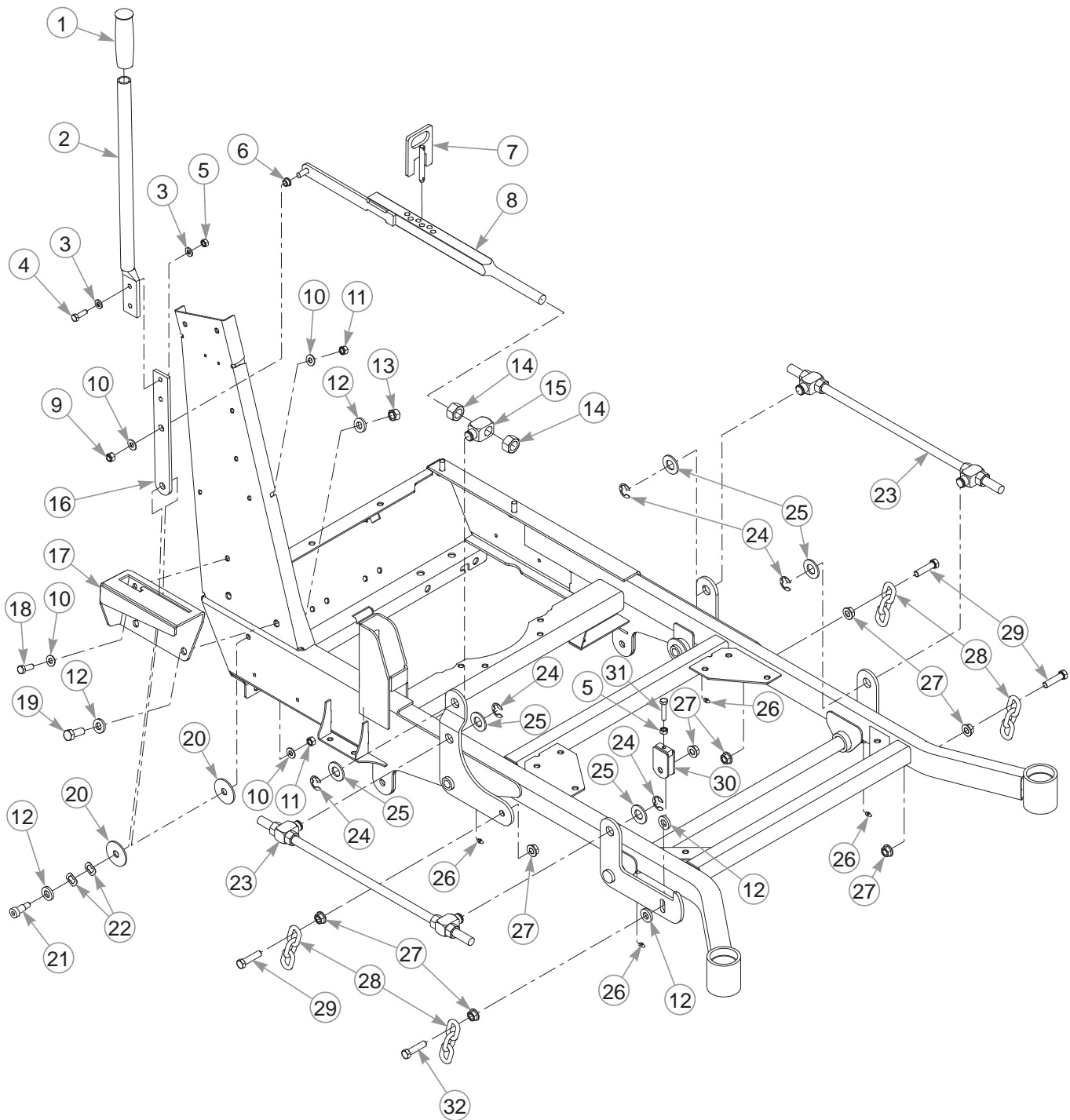

48" & 54" Deck Lift

INDEX NO.	PART NO.	QTY.	DESCRIPTION
1	792317	1	GRIP
2	110570	1	DECK LIFT HANDLE
3	768523	4	FW .343 X .687 X .051/.080H
4	036236	2	CS .312-18 X 1.00 HX G5
5	034272	3	NT .312-18 HX G5
6	765339	1	BUSHING
7	348284	1	HEIGHT ADJ STOP
8	110529	1	DECK INDICATOR
9	086660	1	NT .375-16 HX G5 NL
10	767954	4	FW .379 X .813 X .063
11	054502	2	NT .375-16 HX G5 ZNY
12	767962	13	FW .531 X 1.063 X .175
13	008193	2	NT .500-13 HX G5 ZNYC
14	008417	2	NT .750-10 HX G5 ZNYC
15	781930	1	DECK LIFT MT BLOCK
16	110530	1	LOWER HANDLE
17	550073	1	DECK LIFT BRACKET
18	036244	1	CS .375-16 X 1.00 HX G5
19	705954	2	CS .500-13 X 1.25 HX G5
20	263517	2	BEARING DISC
21	728550	1	SB .50 X .75SH .375-16TD
22	601953	2	WASHER, WAVY .558 X 1.005
23	601942	2	DECK LIFT ROD NO SPRING
24	781294	5	E CLIP 1.00 X .625 X .05
25	601681	5	FW .781 X 1.50 X .120 ZNYC
26	015495	4	GREASE FITTING STRAIGHT
27	704643	16	NT .437-14 HX FLG ZN
28	360131	4	DECK LIFT CHAIN
29	055749	7	CS .437-14 X 1.75 HX G5
30	348458	1	DECK LEVELER YOKE
31	756270	1	CS .312-18 X 1.50 HX G5
32	781831	1	CS .437-14 X 1.75 HX G5

NOTES:

48" & 54" Deck Mounting Hardware

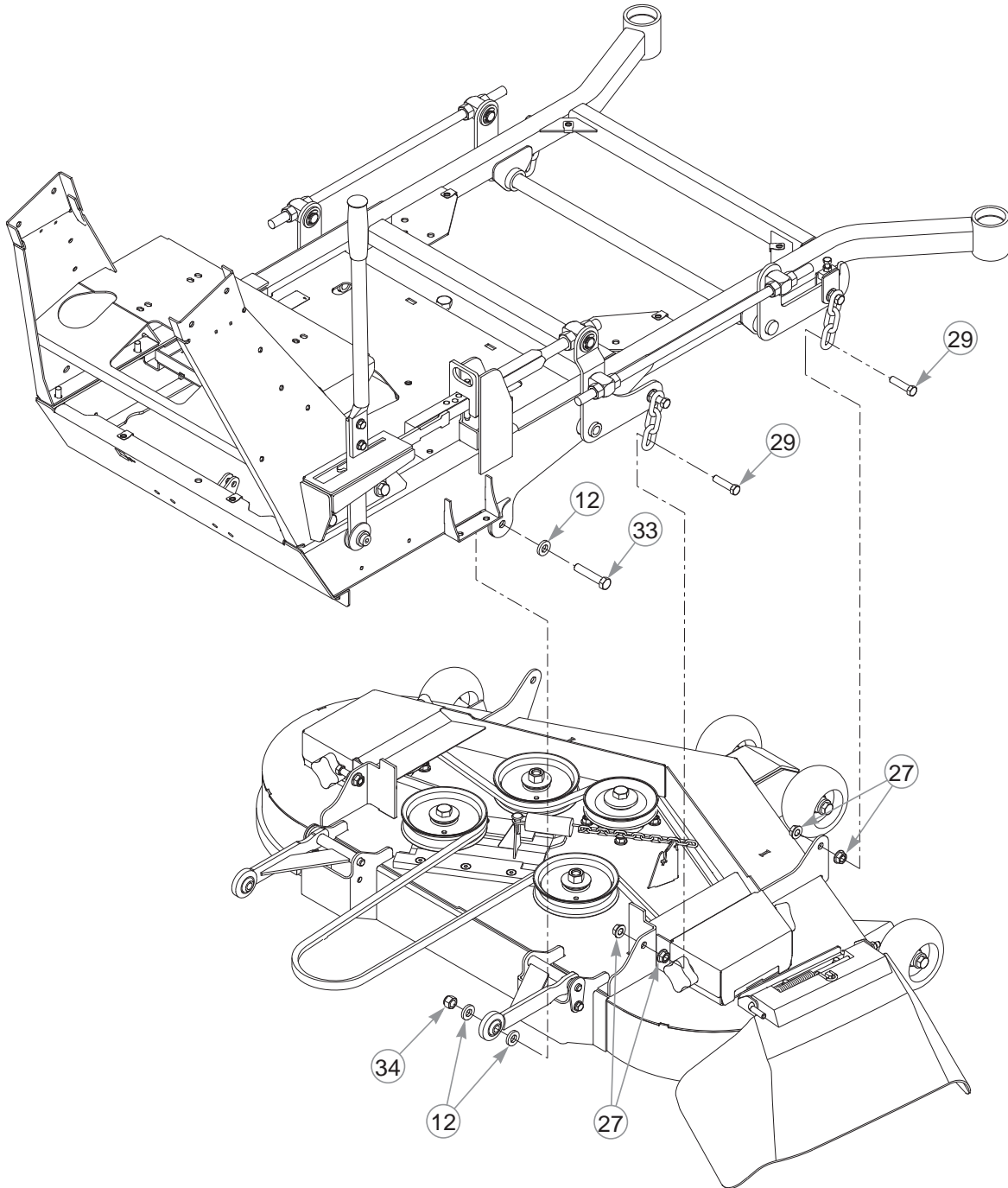

INDEX NO.	PART NO.	QTY.	DESCRIPTION
33	008573	2	CS .500-13 X 2.50 HX G5
34	781567	2	NT .500-13 HX G8 ZY NL

NOTES:

This page intentionally left blank.

Spindle Service Parts

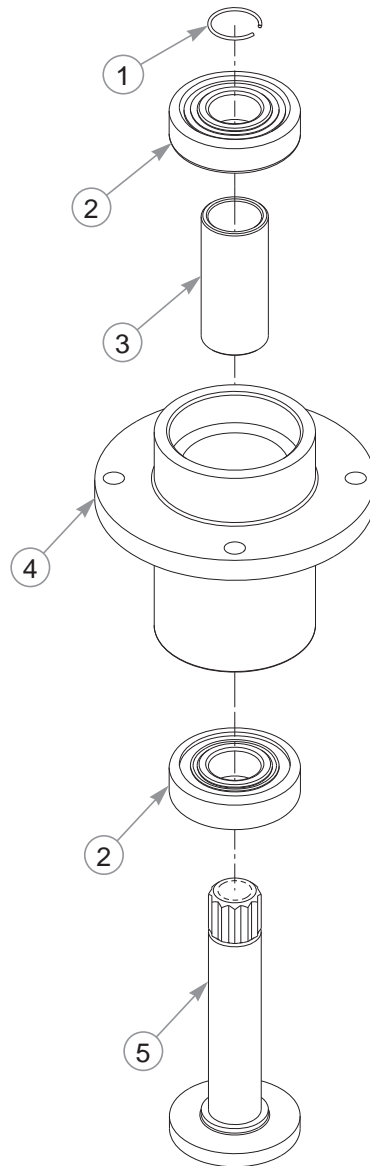

INDEX NO.	PART NO.	QTY.	DESCRIPTION
1	783548	1	RETAINING RING
2	783555	2	BEARING
3	783530	1	SPACER
4	783514	1	HOUSING
5	783522	1	SHAFT

NOTES: