



Click Here To View
Item at

www.GapPower.com

Sales • Rentals
Parts & Service

BOMAG

FAYAT GROUP

Vibratory Tamper

BT60/4 BT65/4



Easy to access controls.



All around engine protection.



Dual air filter system helps extend the life of the engine.



Technical Specifications

BT60/4 BT65/4

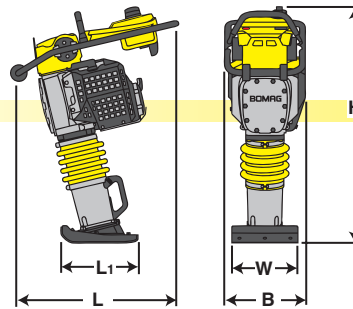

Shipping dimensions in cubic feet (m³)

BT60/4	19.3	(0.547)
BT65/4	19.3	(0.547)

Standard Equipment

- Reliable Honda 4-stroke engine
- Electronic ignition
- Splash oil lubrication
- Acceleration pump
- Hour / Tachometer with integrated service indicator
- Corrosion-free plastic fuel tank
- Polyethylene shoe with steel wear plate
- Centrifugal clutch
- Infinitely variable frequency
- Anti-vibration handle
- Easy access shut-down switch
- Dual self cleaning air filter system
- Dual fuel filter system
- Diaphragm carburetor
- Recoil starter with integral guard
- Narrow leg bellows
- Engine protection covers and guards

Optional Equipment

- Transport wheels
- Interchangeable Shoe Kits
6", 9", 11", 13"
- 15" Tall Tamper Foot Extension Kits
4" or 6" shoe widths
- Service kit

Dimensions

inches (mm)	B	H	L	L ₁	W
BT60/4	13.8 (350)	37.8 (960)	28.9 (735)	13.2 (335)	11.0 (280)
BT65/4	13.8 (350)	39.4 (1000)	28.9 (735)	13.2 (335)	11.0 (280)

Technical data

Weights

	lbs	(kg)	BOMAG BT60/4	BOMAG BT65/4
Basic weight	134	(61)	134	148
Operating weight	137	(62)	137	150

Dimensions

Dimensions	see sketch	see sketch
------------	------------	------------

Driving characteristics (depending on site conditions)

	ft/min	(m/min)	BOMAG BT60/4	BOMAG BT65/4
Working speed max	66	(20)	66	66
Area coverage max	3616	(336)	3616	3616

Drive

	Honda	Honda
Engine manufacturer	Honda	Honda
Type	GX 100 (4-cycle)	GX 100 (4-cycle)
Cooling	air	air
Number of cylinders	1	1
Performance ISO 9249	3.4 (2.5)	3.4 (2.5)
Speed	4200	4200
Fuel	gasoline	gasoline
Fuel consumption max	0.2 (0.8)	0.2 (0.8)
Starting device	recoil	recoil

Vibratory System

	mechanical	mechanical
Drive system	mechanical	mechanical
Frequency	600-708 (10-11.8)	600-708 (10-11.8)
Jumping height	2.4 (60)	2.8 (70)
Impact force	3035 (13.5)	3642 (16.2)
Compaction depth max	22 (55)	26 (65)

Capacities

Fuel	0.8	(3)	0.8	(3)
------	-----	-----	-----	-----

Technical modifications reserved. Machine may be shown with options.



B37H-2859 3M0411TTTT