

INSTRUCTION MANUAL

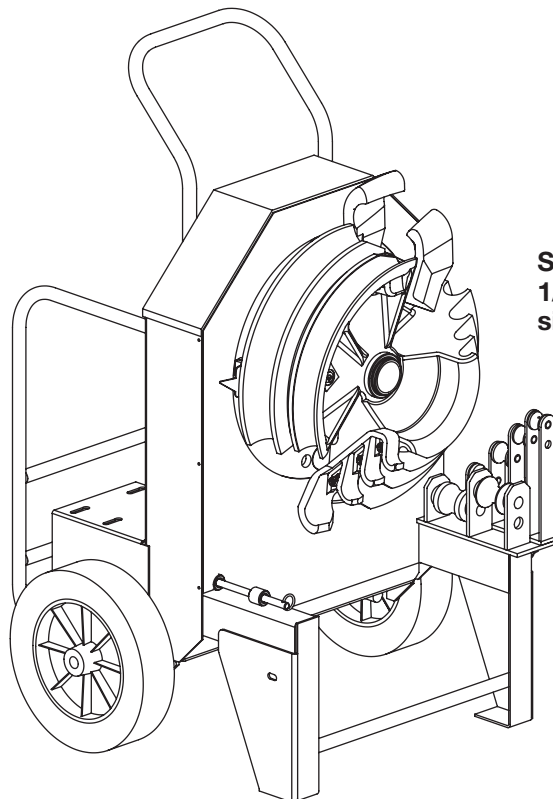

GREENLEE®

A Textron Company



Shown with optional
1/2" to 2" rigid
single-shoe group

555C **Electric Bender Classic**

Serial Codes AFB and ADE



Read and understand all of the instructions and safety information in this manual before operating or servicing this tool.

Register this product at www.greenlee.com

Table of Contents

| | |
|---|-------|
| Description | 2 |
| Safety | 2 |
| Purpose of this Manual | 2 |
| Important Safety Information | 3-4 |
| Grounding Instructions | 5 |
| Identification | 6 |
| Specifications | 6 |
| Bending Attachment Groups | 7-8 |
| Setup | 9-10 |
| Operation | 11-13 |
| Illustrated Bending Glossary | 14 |
| Bending Instructions | 15-16 |
| Additional Bending Instructions | 17-19 |
| Additional Bending Tables | 20-26 |
| Handle Removal and Replacement | 27 |
| Transportation | 27 |
| Maintenance | 28 |
| Troubleshooting | 29-31 |
| Illustrations and Parts Lists | 32-34 |
| Schematic Diagram | 35 |
| Control Assembly | 36 |
| Bending Shoes and Roller Supports | 37-43 |

Description

The Greenlee 555C Electric Bender Classic is intended to bend 1/2" to 2" conduit and pipe.

Bending shoe groups are available to accommodate the following types:

- Electrical Metallic Tubing
- Intermediate Metallic Conduit
- Rigid Conduit
- PVC-Coated Rigid Conduit
- Schedule 40 Pipe

The shoe groups are shown in the "Bending Attachment Groups" section of this manual.

Safety

Safety is essential in the use and maintenance of Greenlee tools and equipment. This instruction manual and any markings on the tool provide information for avoiding hazards and unsafe practices related to the use of this tool. Observe all of the safety information provided.

Purpose of this Manual

This manual is intended to familiarize personnel with the safe operation and maintenance procedures for the following Greenlee tool:

555C Electric Bender Classic
Serial Codes AFB and ADE

Keep this manual available to all personnel.

Replacement manuals are available upon request at no charge at www.greenlee.com.



Do not discard this product or throw away!

For recycling information, go to www.greenlee.com.

All specifications are nominal and may change as design improvements occur. Greenlee Textron Inc. shall not be liable for damages resulting from misapplication or misuse of its products.

Loctite is a registered trademark of Henkel Corp.

Mobil is a registered trademark of Mobil Oil Corporation.

KEEP THIS MANUAL

IMPORTANT SAFETY INFORMATION



SAFETY ALERT SYMBOL

This symbol is used to call your attention to hazards or unsafe practices which could result in an injury or property damage. The signal word, defined below, indicates the severity of the hazard. The message after the signal word provides information for preventing or avoiding the hazard.

⚠️ DANGER

Immediate hazards which, if not avoided, **WILL** result in severe injury or death.

⚠️ WARNING

Hazards which, if not avoided, **COULD** result in severe injury or death.

⚠️ CAUTION

Hazards or unsafe practices which, if not avoided, **MAY** result in injury or property damage.



⚠️ DANGER

Read and understand all of the instructions and safety information in this manual before operating or servicing this tool.

Failure to observe this warning will result in severe injury or death.



⚠️ DANGER

Do not use this tool in a hazardous environment. Hazards include flammable liquids, gases, or other materials. Using this tool in a hazardous environment can result in a fire or explosion.

Failure to observe this warning will result in severe injury or death.



⚠️ WARNING

Electric shock hazard:

- Connect the power cord to a 120 volt, 20 amp receptacle on a ground fault protected circuit only. See "Grounding Instructions."
- Do not modify the power cord or plug.
- Inspect the power cord before use. Repair or replace the cord if damaged.
- Disconnect from power before servicing.

Failure to observe these warnings could result in severe injury or death.



⚠️ WARNING

- Do not expose to rain.
- Do not use in wet or damp locations.

Failure to observe these warnings could result in severe injury or death.



⚠️ WARNING

Wear eye protection when operating or servicing this tool.

Failure to wear eye protection could result in serious eye injury from flying debris.



⚠️ WARNING

Do not remove guards.



Failure to observe this warning could result in severe injury or death.

IMPORTANT SAFETY INFORMATION

| | |
|---|---|
|  | <p>⚠ WARNING</p> |
| | <p>Extension cords:</p> <ul style="list-style-type: none"> • Use only three-wire, 12-gauge extension cords that have three-prong grounding-type plugs and three-hole receptacles that accept the tool's plug. • Do not use extension cords that are longer than 30 m (100'). • Repair or replace damaged extension cords. <p>Failure to observe these warnings could result in severe injury or death.</p> |

| |
|---|
| <p>⚠ WARNING</p> |
| <p>Make sure that the handle is properly installed and secured with the safety spring clips and snap pins before lifting or moving the bender. An improperly installed handle could allow the bender to fall, injuring nearby personnel.</p> <p>Failure to observe this warning could result in severe injury or death.</p> |

| | |
|---|--|
|  | <p>⚠ WARNING</p> |
| | <p>Pinch points:</p> <p>Keep hands away from bending shoe, rollers and conduit when bender is in use.</p> <p>Failure to observe this warning could result in severe injury or death.</p> |

| |
|---|
| <p>⚠ WARNING</p> |
| <p>Unplug the bender before changing accessories. Accidental start-up could result in serious injury.</p> |

| | |
|---|---|
|  | <p>⚠ CAUTION</p> |
| | <p>Do not use as a step or ladder.</p> <p>Failure to observe this precaution could result in injury or property damage.</p> |

| |
|--|
| <p>⚠ CAUTION</p> |
| <ul style="list-style-type: none"> • Conduit moves rapidly as it is bent. The path of the conduit must be clear of obstructions. Be sure clearance is adequate before starting the bend. • Do not operate the bender while wearing loose clothing. Loose clothing can get caught in moving parts. • Inspect the bender before use. Replace worn, damaged or missing parts with Greenlee replacement parts. A damaged or improperly assembled component could break and strike nearby personnel. • Some bender parts and accessories are heavy and may require more than one person to lift and assemble. • Use this tool for the manufacturer's intended purpose only. Use other than that which is instructed in this manual can result in injury or property damage. <p>Failure to observe these precautions could result in injury or property damage.</p> |

Note: Keep all decals clean and legible, and replace when necessary.

Grounding Instructions

| | |
|---|--|
|  | ⚠ WARNING |
| | <p>Electric shock hazard:</p> <ul style="list-style-type: none">• Do not modify the plug provided with the tool.• Connect this tool to a grounded receptacle on a 20 amp ground fault protected circuit. <p>Failure to observe these warnings could result in severe injury or death.</p> |

This tool must be grounded. In the event of a malfunction or breakdown, an electrical ground provides a path of least resistance for the electric current. This path of least resistance is intended to reduce the risk of electric shock.

This tool's electric cord has a grounding conductor and a grounding plug as shown. Do not modify the plug. Connect the plug to a corresponding GFCI-protected receptacle that is properly installed and grounded in accordance with all national and local codes and ordinances.

Do not use an adapter.

NEMA L5-20 Twist-Lock 20 Amp/120 Volt Plug and Receptacle

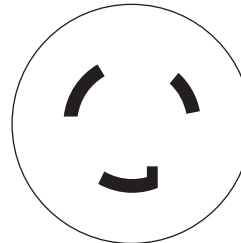

Plug

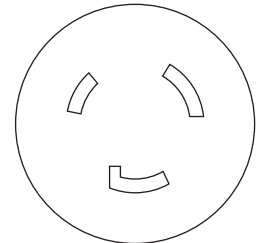

Receptacle

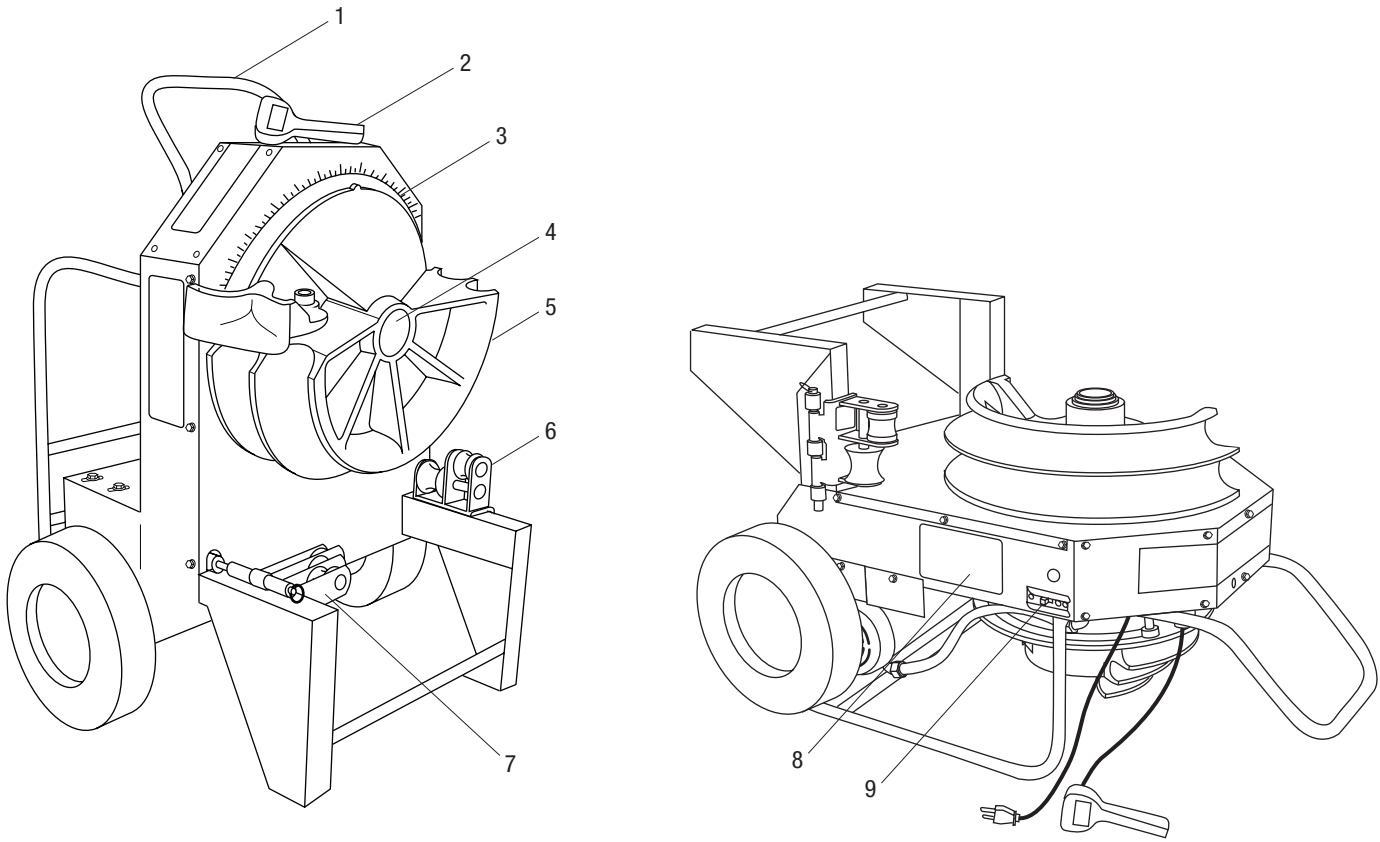
Identification

555RC Electric Bender (shown)

- | | |
|-----------------|---|
| 1. Handle | 6. 1-1/2" to 2" Roller Support |
| 2. Pendant | 7. 1/2" to 1-1/4" Roller Support (in storage position) |
| 3. Protractor | 8. Bending Instructions Decal |
| 4. Main Shaft | 9. Circuit Breaker (ON/OFF switch) |
| 5. Bending Shoe | |

Specifications

| | |
|--|--|
| Height | 1118 mm (44") |
| Width | 724 mm (28.5") |
| Depth | 521 mm (20.5") |
| Mass/Weight (bender without shoes or roller supports)..... | 118 kg (260 lb) |
| Power Supply | 120 VAC, 20 amp GFCI-protected receptacle |
| Operating Conditions | |
| Temperature | -20 °C to 49 °C (-5 °F to 120 °F) |
| Relative Humidity | 0 to 98% |
| Capacity | 1/2" to 2" conduit, schedule 40 pipe |

Bending Attachment Groups

RIGID SINGLE SHOE

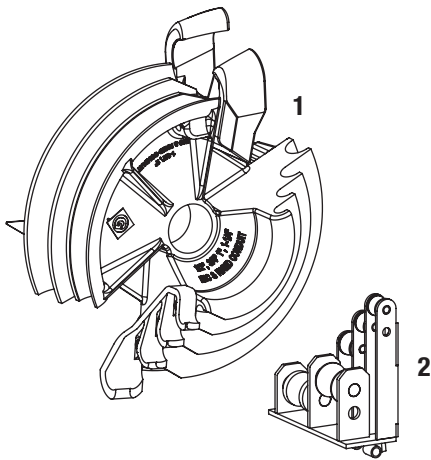

28008: 1/2" to 2" Rigid
1/2" to 1-1/4" IMC
1/2" to 2" Schedule 40 Pipe

| Key | UPC No. 78-3310- | Description |
|-----|---------------------|------------------------------------|
| 1 | 02548 | Bending shoe for 1/2" to 2" |
| 2 | 02549 | Roller support unit for 1/2" to 2" |
| | 23818 | Storage box |

IMC SINGLE SHOE

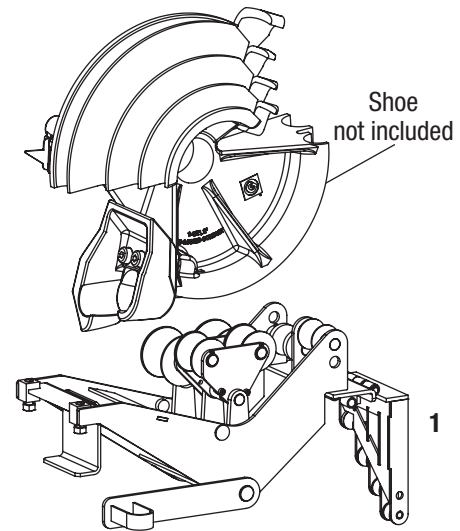

01323: 1/2" to 2" IMC

| Key | UPC No. 78-3310- | Description |
|-----|---------------------|-------------------------|
| 1 | 01323 | Roller support assembly |

Note: 02548 rigid/IMC shoe is required to use the 01323 roller support on the 555C bender.

EMT SINGLE SHOE

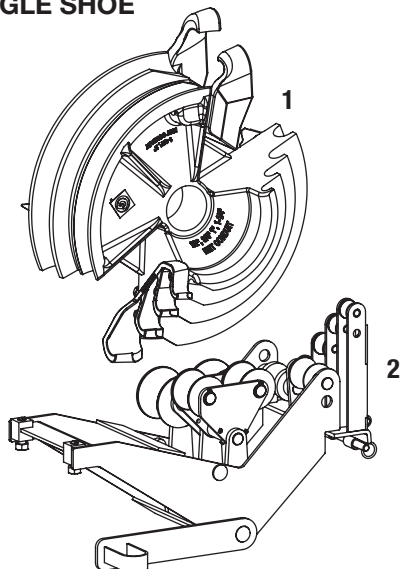

23803: 1/2" to 2" EMT

| Key | UPC No. 78-3310- | Description |
|-----|---------------------|------------------------------------|
| 1 | 02543 | Bending shoe for 1/2" to 2" |
| 2 | 02544 | Roller support unit for 1/2" to 2" |
| | 23818 | Storage box |

PVC-COATED RIGID SINGLE SHOE

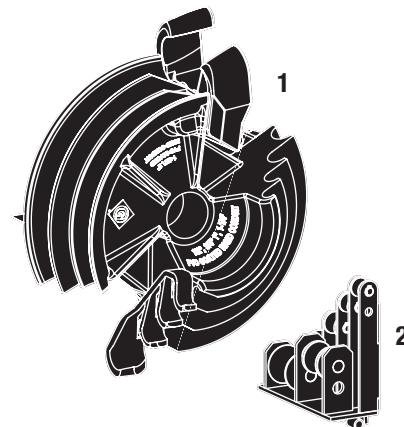

12586: 1/2" to 2" 40 Mil PVC-Coated Rigid

| Key | UPC No. 78-3310- | Description |
|-----|---------------------|------------------------------------|
| 1 | 02553 | Bending shoe for 1/2" to 2" |
| 2 | 02554 | Roller support unit for 1/2" to 2" |
| | 23818 | Storage box |

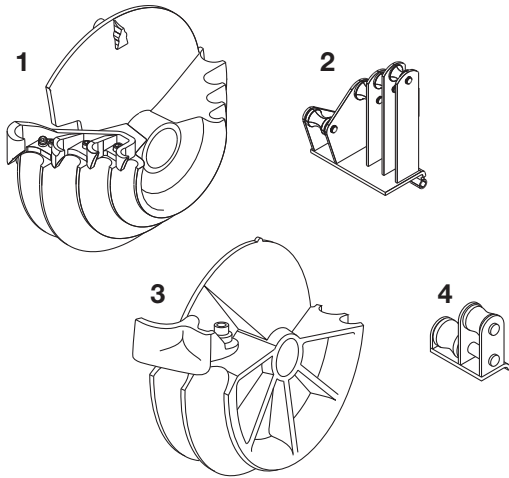
Bending Attachment Groups (cont'd)
RIGID

**28007: 1/2" to 1-1/4" IMC
1/2" to 2" Rigid Steel
1/2" to 2" Schedule 40 Pipe**

| Key | UPC No. 78-3310- | Description |
|-----|---------------------|--|
| 1 | 00571 | Bending shoe for 1/2" to 1-1/4" |
| 2 | 00936 | Roller support unit for 1/2" to 1-1/4" |
| 3 | 17937 | Bending shoe for 1-1/2" to 2" |
| 4 | 17984 | Roller support unit for 1-1/2" to 2" |

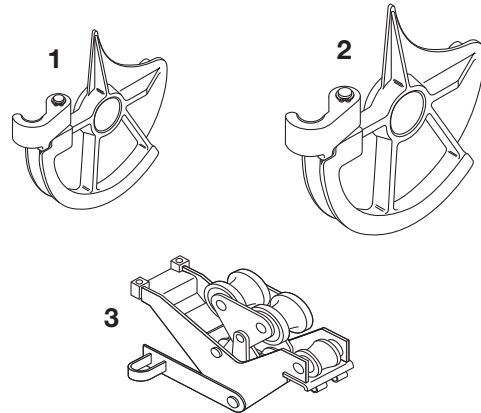
IMC

26330: 1-1/2" to 2" IMC

| Key | UPC No. 78-3310- | Description |
|-----|---------------------|--------------------------------------|
| 1 | 25263 | Bending shoe for 1-1/2" |
| 2 | 25268 | Bending shoe for 2" |
| 3 | 25273 | Roller support unit for 1-1/2" to 2" |
| | 23818 | Storage box |

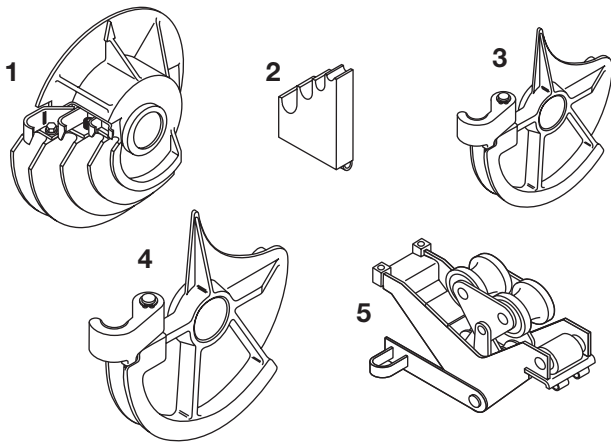
EMT

23802: 1/2" to 2" EMT

| Key | UPC No. 78-3310- | Description |
|-----|---------------------|--|
| 1 | 17944 | Bending shoe for 1/2" to 1-1/4" |
| 2 | 17986 | Roller support unit for 1/2" to 1-1/4" |
| 3 | 23499 | Bending shoe for 1-1/2" |
| 4 | 23505 | Bending shoe for 2" |
| 5 | 23541 | Roller support unit for 1-1/2" to 2" |
| | 23818 | Storage box |

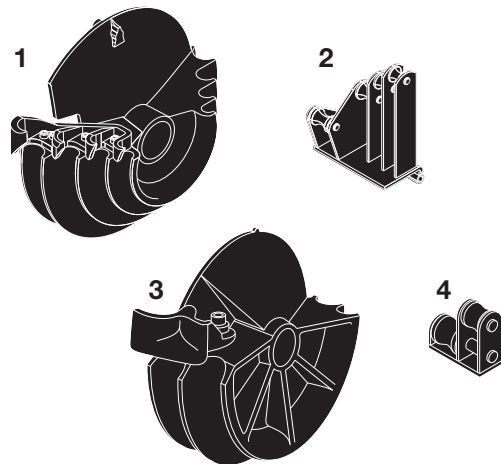
PVC-COATED RIGID

37279: 1-1/2" to 2" 40 Mil PVC-Coated Rigid

| Key | UPC No. 78-3310- | Description |
|-----|---------------------|--|
| 1 | 00573 | Bending shoe for 1/2" to 1-1/4" |
| 2 | 00946 | Roller support unit for 1/2" to 1-1/4" |
| 3 | 37281 | Bending shoe for 1-1/2" to 2" |
| 4 | 37282 | Roller support unit for 1-1/2" to 2" |
| | 23818 | Storage box |

Setup

| | |
|---|---|
|  | ⚠ WARNING |
| | Wear eye protection when operating or servicing this tool. Failure to wear eye protection could result in serious eye injury from flying debris. |

| |
|---|
| ⚠ WARNING |
| Unplug the bender before changing accessories. Accidental start-up could result in serious injury. |

1. Slide the appropriate bending shoe onto the shaft of the main sprocket, as shown. Align the four drive studs on the back of the shoe with the four holes in the main sprocket.

Note: 1-1/2" and 2" EMT and IMC single-groove bending shoes have only three drive studs.

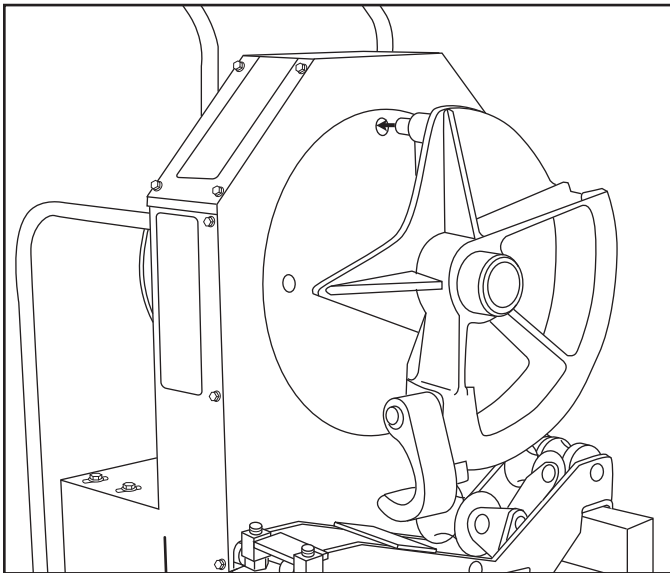
**Installing a Bending Shoe**

2. Mount the appropriate support unit onto the leg of the bender and install the hinge pin, as shown.

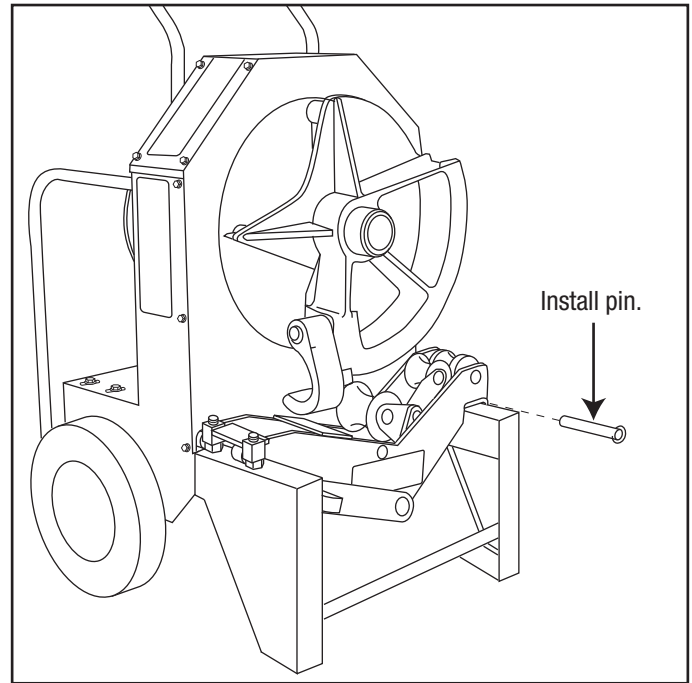
**Roller Support Unit Installed**

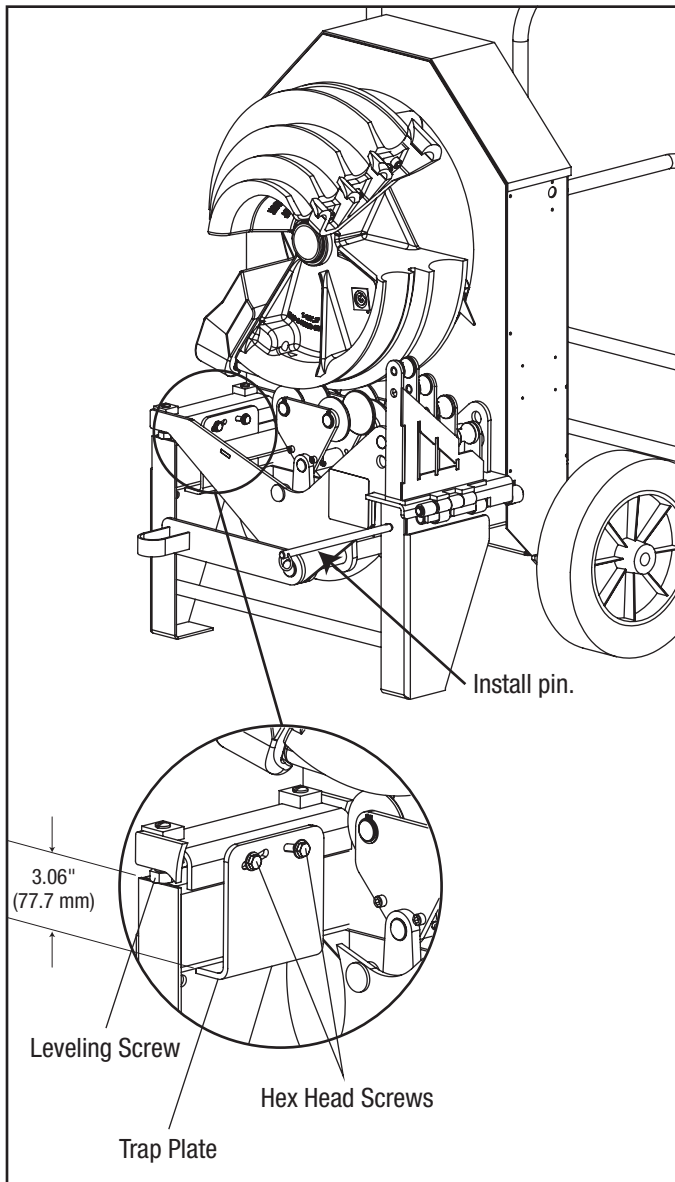
Setup (cont'd)**IMC Single-Shoe Roller Support Unit Installed**

Note: The IMC single-shoe roller support has a trap plate that may require adjustment to properly fit around the leg of the bender. Verify that the trap plate is 3.06" (77.7 mm) below the leveling screws. If necessary, loosen the two hex head screws and adjust the distance. Retighten the screws.

3. Mark the conduit. See the decals on the bender or the "Additional Bending Instructions" section of this manual.
4. Place the bender in either the vertical or horizontal bending position.

Operation

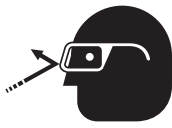
| | |
|---|--|
|  | ⚠ WARNING |
| | <p>Wear eye protection when operating or servicing this tool.</p> <p>Failure to wear eye protection could result in serious eye injury from flying debris.</p> |

| | |
|---|--|
|  | ⚠ WARNING |
| | <p>Pinch points:</p> <p>Keep hands away from bending shoe, rollers and conduit when bender is in use.</p> <p>Failure to observe this warning could result in severe injury or death.</p> |

| |
|--|
| ⚠ WARNING |
| <p>Do not operate the bender while wearing loose clothing. Loose clothing can get caught in moving parts.</p> <p>Failure to observe this warning could result in severe injury or death.</p> |

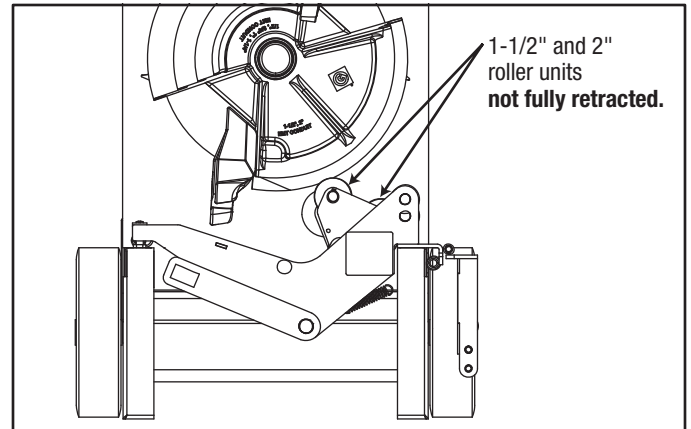

To fully retract the rollers, depress the loading pedal until the arm contacts the stop and remove your foot from the loading pedal. The 1-1/2" and 2" roller units should drop into the fully retracted position. If not, use one hand to slightly press the loading pedal, and use a tool (e.g., screwdriver) to adjust the roller so that both rollers rotate counterclockwise to the retracted position. Using a tool to adjust the roller will keep hands and fingers clear from any potential pinch points.

RETRACTING 1-1/2" AND 2" ROLLER UNITS

Note: The 02544 EMT bridge unit and 01323 IMC/rigid bridge unit have a spring to properly engage the 1-1/2" and 2" roller units when the loading pedal is depressed. Before loading conduit or rotating the shoe hook past the rollers, check that the 1-1/2" and 2" roller units are in the fully retracted position as shown.

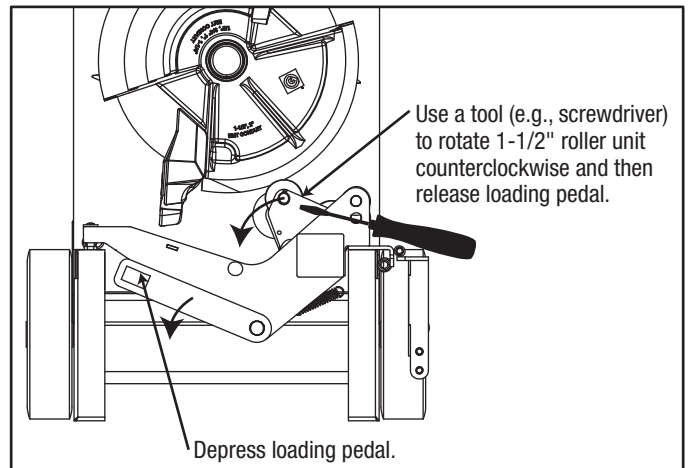
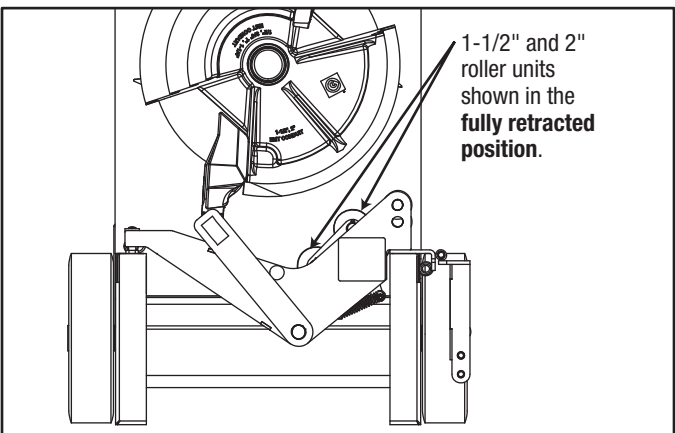

Operation (cont'd)
BENDING CONDUIT

1. Plug the cord into an appropriate receptacle. See "Grounding Instructions."
2. Press BEND or UNLOAD until the shoe is 5° to 10° before the 0° starting point.
3. Load the conduit so that the bending mark is aligned with the front edge of the shoe hook, as illustrated.

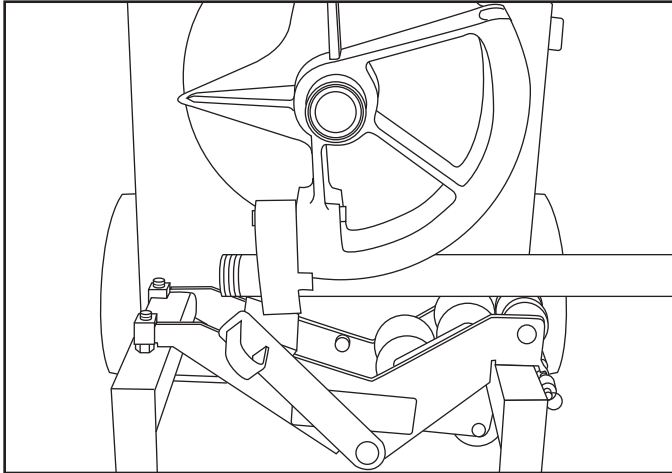

Loading the Conduit

4. See the instruction decal for the appropriate bend angle.

5. Bend the conduit:

If bending 1-1/2" to 2" EMT or IMC:

- a. Place one foot on the loading pedal, as shown.

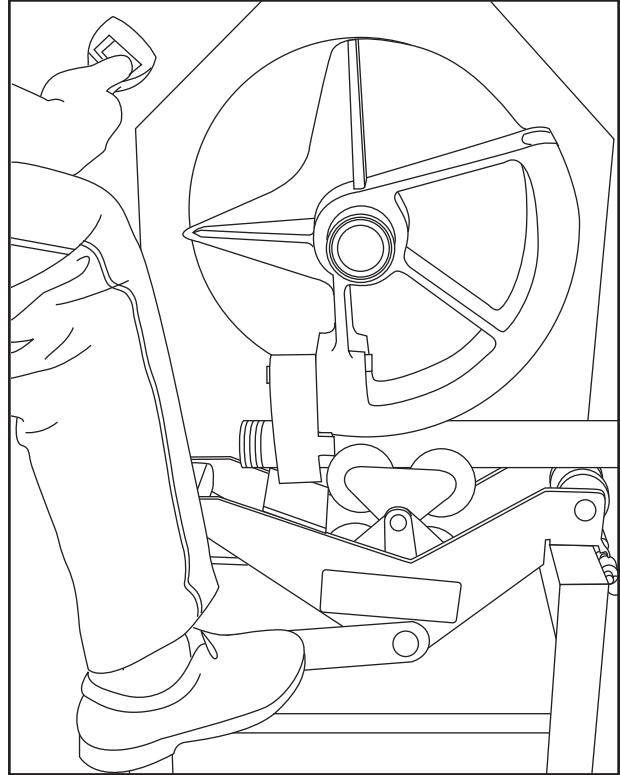

**Engaging the Loading Pedal
(for 1-1/2" to 2" EMT or IMC only)**

- b. Press and hold BEND. The bender will pull up the roller support. When the roller support contacts the stop, remove your foot from the loading pedal.
 - c. Release the switch as you approach the desired angle of bend.
 - d. Press BEND momentarily until the bend is complete.
- If bending any other size or type of conduit:**
- a. Press and hold BEND.
 - b. Release the switch as you approach the desired angle of bend.
 - c. Press BEND momentarily until the bend is complete.
6. Press UNLOAD. The shoe will rotate backward.
Note: If bending EMT or IMC, the roller support unit will drop to its original position.
 7. Twist the conduit to release it from the hook. Remove the conduit.
 8. Press and hold UNLOAD until the shoe has rotated back to 0°.

Operation (cont'd)

ADJUSTING THE SQUEEZE

When bending 1-1/2" to 2" EMT or IMC, the roller support must be engaged so that it contacts the conduit; the pressure against the conduit is the "squeeze."

Due to variations in conduit, the standard adjustment may provide too much or too little squeeze. If the conduit develops excessive side marking when bent, the squeeze is set too high. If the conduit becomes excessively oval or wrinkled, the squeeze is set too low.

1. Use a screwdriver to loosen the set screws.
2. Use a wrench to rotate both adjusting bolts 1/2 turn clockwise to INCREASE squeeze or 1/2 turn counterclockwise to DECREASE squeeze.

Note: In order to distribute the load evenly, adjust both bolts to the same setting. See the illustration.

3. Tighten the set screws.

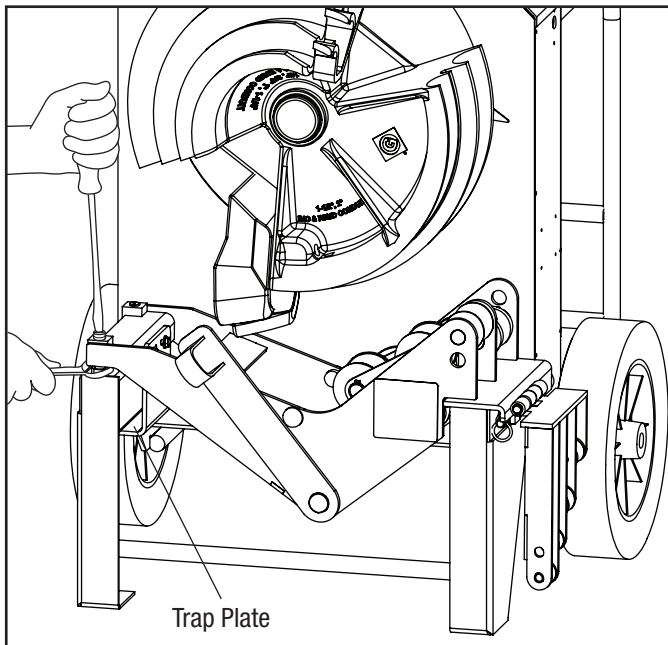

Adjusting the Squeeze

Note: The IMC single-shoe roller support has a trap plate that may require adjustment to allow an increase in squeeze. Refer to the trap plate adjustment procedures under "Setup."

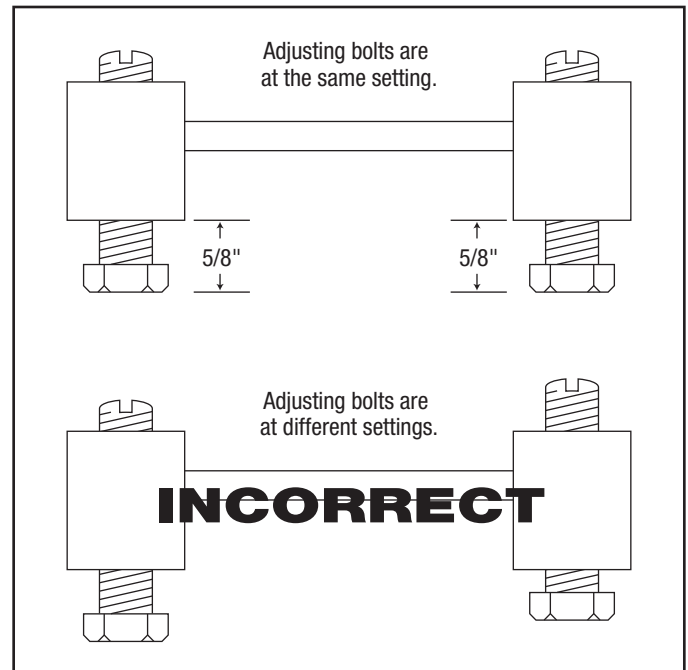

Standard Squeeze Setting

ARROW ADJUSTMENT

The arrows on the single shoes can be adjusted to compensate for variations in conduit.

1. Load the conduit into the proper shoe groove.
2. Press BEND momentarily until the shoe rotates enough so that the conduit is snug in the hook.
3. Verify that the arrow position is aligned with 0° on the front protractor scale. If necessary, loosen the hex head screw and adjust the arrow to align with 0°. Retighten the hex head screw, as shown.

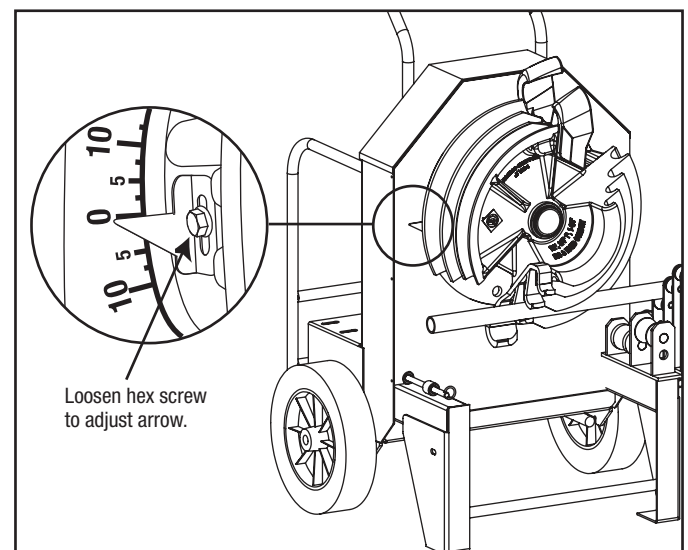

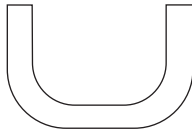
Illustrated Bending Glossary

back-to-back bend — any U-shaped bend formed by two parallel 90° bends with a straight section of conduit or pipe between the bends.

center-to-center distance — the distance between the successive bends that make up an offset or a three-bend saddle.

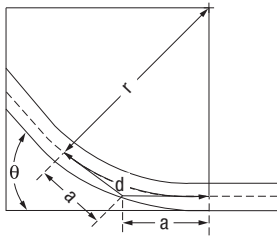

developed length — the actual length of pipe that will be bent; refer to distance “d” in the illustration at left.

gain — the difference between the straight-line distance ($a + a$) and the shorter radial distance, (d) where:

θ = angle of bend

r = the centerline bending radius of the bending shoe

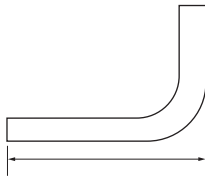

kick — single bend of less than 90°

leg length — the distance from the end of a straight section of conduit or pipe to the bend; measured from the end to the outside edge of the conduit or pipe.

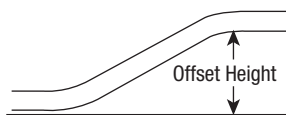

offset bend — two opposite bends with the same degree of bend; used to avoid an obstruction.

offset height — the distance between the two legs of an offset bend, measured perpendicular to the two legs; also called amount of offset and depth of offset.

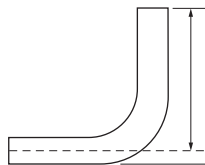

rise — the distance from the end of a straight section of conduit or pipe to the bend; measured from the end to the center line of the conduit or pipe. Also called stub or stub-up.

saddle — a three-bend or four-bend combination; used to avoid an obstruction.

shrink — the amount of conduit “lost” when laying out an offset bend working toward an obstruction.

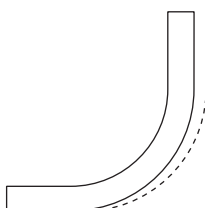

springback — the amount, measured in degrees, that a conduit or pipe tends to straighten after being bent.

Bending Instructions

90° STUBS

1. Measure the length of the required stub.
2. See the Minimum Stub Length formula on the Deduct Table. The required stub must be equal to or longer than the Minimum Stub Length.
3. Measure and mark the stub length on the conduit. This is Mark 1. Subtract the Deduct from this mark and make a new mark. This is Mark 2.
4. Align Mark 2 with the front edge of the hook and bend the conduit.

Notes:

When the operator presses UNLOAD, the conduit may spring back a few degrees. Compensate by overbending as shown in the Scale Reading Table.

The shoes in the 28007 and 37279 groups can make a 180° bend in one shot. All other shoes bend to 90° maximum.

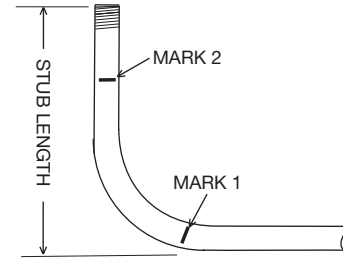
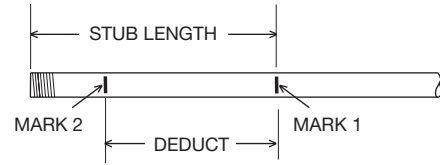

Deduct Table

| SIZE | | 1/2 | 3/4 | 1 | 1-1/4 | 1-1/2 | 2 |
|---|-----------|-------|-------|--------|--------|--------|--------|
| DEDUCT | RIGID/PVC | 7-1/2 | 9 | 11 | 14 | 14-1/4 | 16-1/8 |
| | EMT | 7 | 8-7/8 | 10-3/4 | 13-1/8 | 13-7/8 | 15-3/8 |
| | IMC | 7-1/2 | 9 | 11 | 14 | 13-3/4 | 15-1/4 |
| MINIMUM STUB LENGTH = DEDUCT PLUS 2 INCHES | | | | | | | |

Figures are approximate.

Scale Reading Table

| CONDUIT SIZE | RIGID | | | | | EMT | | | | | IMC | | | | | PVC-COATED | | | | |
|--------------|--------|--------|--------|--------|--------|--------|--------|--------|--------|--------|--------|--------|--------|--------|--------|------------|--------|--------|--------|--------|
| | 15° | 30° | 45° | 60° | 90° | 15° | 30° | 45° | 60° | 90° | 15° | 30° | 45° | 60° | 90° | 15° | 30° | 45° | 60° | 90° |
| 1/2 | 18-3/4 | 35 | 50 | 66-1/4 | 96-1/4 | 16-1/4 | 32-1/2 | 47-1/2 | 63-3/4 | 95 | 20 | 36-1/4 | 51-1/4 | 67-1/2 | 98-3/4 | 17-1/2 | 33-3/4 | 48-3/4 | 65 | 95 |
| 3/4 | 17-1/2 | 32-1/2 | 47-1/2 | 63-3/4 | 95 | 17-1/2 | 33-3/4 | 48-3/4 | 63-3/4 | 95 | 20 | 36-1/4 | 51-1/4 | 67-1/2 | 97-1/2 | 17-1/2 | 33-3/4 | 48-3/4 | 63-3/4 | 95 |
| 1 | 17-1/2 | 33-3/4 | 48-3/4 | 65 | 95 | 17-1/2 | 32-1/2 | 48-3/4 | 65 | 95 | 21-1/4 | 36-1/4 | 51-1/4 | 66-1/4 | 97-1/2 | 17-1/2 | 32-1/2 | 47-1/2 | 63-3/4 | 95 |
| 1-1/4 | 18-3/4 | 33-3/4 | 48-3/4 | 63-3/4 | 95 | 17-1/2 | 33-3/4 | 48-3/4 | 65 | 95 | 18-3/4 | 33-3/4 | 50 | 65 | 96-1/4 | 18-3/4 | 33-3/4 | 50 | 65 | 95 |
| 1-1/2 | 18-3/4 | 33-3/4 | 48-3/4 | 65 | 95 | 16-1/4 | 31-1/4 | 46-1/4 | 61-1/4 | 92-1/2 | 17-1/2 | 33-3/4 | 48-3/4 | 63-3/4 | 95 | 18-3/4 | 33-3/4 | 48-3/4 | 65 | 95 |
| 2 | 20 | 35 | 48-3/4 | 63-3/4 | 96-1/4 | 17-1/2 | 33-3/4 | 48-3/4 | 63-3/4 | 95 | 20 | 35 | 50 | 65 | 96-1/4 | 20 | 35 | 48-3/4 | 63-3/4 | 96-1/4 |

Figures are approximate.

Scale Reading Table—Single-Shoe Groups

| CONDUIT SIZE | RIGID | | | | | EMT | | | | | IMC | | | | | PVC-COATED RIGID | | | | |
|--------------|-------|-----|-----|-----|-----|-----|-----|-----|-----|-----|-----|-----|-----|-----|-----|------------------|-----|-----|-----|-----|
| | 15° | 30° | 45° | 60° | 90° | 15° | 30° | 45° | 60° | 90° | 15° | 30° | 45° | 60° | 90° | 15° | 30° | 45° | 60° | 90° |
| 1/2 | 17 | 33 | 49 | 64 | 96 | 16 | 32 | 48 | 63 | 95 | 20 | 36 | 51 | 67 | 98 | 16 | 31 | 47 | 62 | 93 |
| 3/4 | 17 | 33 | 48 | 64 | 95 | 17 | 33 | 48 | 64 | 95 | 19 | 35 | 50 | 66 | 97 | 15 | 31 | 46 | 62 | 93 |
| 1 | 17 | 32 | 48 | 63 | 94 | 17 | 32 | 48 | 63 | 94 | 19 | 35 | 50 | 66 | 97 | 16 | 32 | 47 | 63 | 94 |
| 1-1/4 | 17 | 32 | 48 | 63 | 94 | 17 | 32 | 48 | 63 | 94 | 19 | 35 | 50 | 66 | 97 | 15 | 30 | 46 | 61 | 92 |
| 1-1/2 | 17 | 32 | 48 | 63 | 94 | 19 | 35 | 50 | 66 | 97 | 17 | 33 | 49 | 64 | 96 | 18 | 33 | 49 | 64 | 95 |
| 2 | 17 | 32 | 48 | 63 | 94 | 19 | 34 | 50 | 65 | 96 | 19 | 34 | 50 | 65 | 96 | 19 | 34 | 50 | 65 | 96 |

Figures are approximate. Note: Due to varying conduit material properties, 1-1/2" or 2" aluminum rigid may require IMC squeeze rollers for bending. If flattening occurs, reduce the squeeze setting two positions and use IMC bending procedures.

Bending Instructions (cont'd)

Offsets

1. Measure the height and length of the obstruction. Select the angle to be used.
2. See the Offset Table. The height of the obstruction must be equal to or greater than the minimum offset.
3. Refer to the X Table to find the X dimension. Refer to the Offset Table to find the center-to-center distance.

Note: If the center-to-center distance is not shown, calculate it by using the multipliers shown in the Offset Table.

4. Mark the conduit as shown.
5. Insert the conduit into the bender. Align Mark 1 with the front edge of the hook and bend the conduit.
6. Align Mark 2 with the front edge of the hook. Without removing the conduit from the bender, rotate the conduit 180°. Make the second bend.

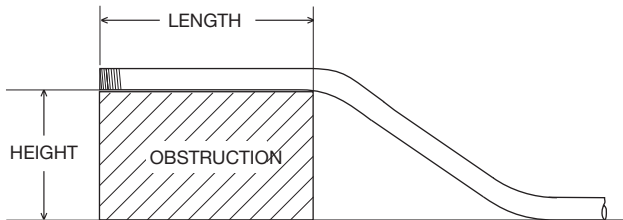
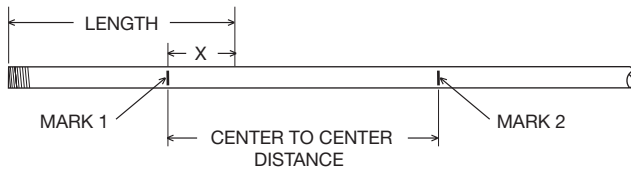

Offset Table

| OFFSET ▶ | | 2 | 4 | 6 | 8 | 10 |
|----------|-------------------|-------|---------|---------|----------|--------|
| 15° | Max. Conduit Size | 3/4 | 1-1/2 | 2 | | |
| | Center-to-Center | 7-3/4 | 15-7/16 | 23-3/16 | 30-15/16 | 38-5/8 |
| 30° | Max. Conduit Size | | 3/4 | 1 | 1-1/2 | 2 |
| | Center-to-Center | | 8 | 12 | 16 | 20 |
| 45° | Max. Conduit Size | | | 1/2 | 1 | 1-1/4 |
| | Center-to-Center | | | 8-1/2 | 11-5/16 | 14-1/8 |

| OFFSET ▶ | | 12 | 14 | 16 | 18 | 20 | 22 |
|----------|-------------------|----------|----------|----------|---------|--------|--------|
| 15° | Max. Conduit Size | 2 | | | | | |
| | Center-to-Center | 46-3/8 | 54-1/16 | 61-13/16 | 69-9/16 | 77-1/4 | 85 |
| 30° | Max. Conduit Size | 2 | | | | | |
| | Center-to-Center | 24 | 28 | 32 | 36 | 40 | 44 |
| 45° | Max. Conduit Size | 1-1/2 | 2 | | | | |
| | Center-to-Center | 16-15/16 | 19-13/16 | 22-5/8 | 25-7/16 | 28-1/4 | 31-1/8 |

CENTER-TO-CENTER DISTANCE = OFFSET HEIGHT x MULTIPLIER

| OFFSET ANGLE | 10° | 15° | 22-1/2° | 30° | 45° |
|--------------|-----|-----|---------|-----|-----|
| MULTIPLIER | 5.8 | 3.9 | 2.6 | 2.0 | 1.4 |

Figures are approximate

X Table

| CONDUIT SIZE | 1/2 | 3/4 | 1 | 1-1/4 | 1-1/2 | 2 |
|--------------|--------|--------|--------|-------|-------|-------|
| "X" | 3-1/16 | 3-1/16 | 3-3/16 | 4 | 4-1/4 | 4-1/2 |

Figures are approximate

Additional Bending Instructions

The following drawings and bending tables are intended to provide the information necessary to accomplish the most common types of bends. The Bending Tables contain conduit marking information.

STUBS

1. Select the size and type of conduit. Determine the height of stub and the angle to be used.
2. Find the table that corresponds to the size and type of conduit selected in Step 1.
3. Under the column labeled ANGLE, find the appropriate angle.
4. Find the row labeled Y. In the row at the top of the page, find the height (H) of the stub. The number shown at the intersection of row Y and column H is the distance Y. Place the bending mark Y inches from the end of the conduit.
5. Bend the conduit.

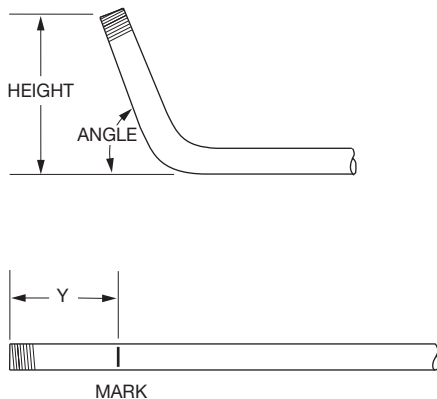

OFFSETS

An offset is used to route the conduit around an obstruction. To make an offset, two equal bends are required. The distance between the two bends is the center-to-center distance.

When working past an obstruction, it is necessary to determine the location of the first bend. The center-to-center distance is then used to determine the location of the second bend. When working toward an obstruction, it is necessary to determine the location of the second bend. The center-to-center distance is then used to determine the location of the first bend.

Working Past an Obstruction

1. Select the size and type of conduit. Measure the height of the obstruction and the distance labeled LENGTH. Determine the angle to be used.
2. Find the table that corresponds to the size and type of conduit selected in Step 1.
3. To the right of the size and type of conduit, find the dimension labeled X. Subtract X from LENGTH. Place the first bending mark this distance from the end of the conduit.
4. Under the column labeled ANGLE, find the appropriate angle. Find the row labeled L1. In the row at the top of the page, find the height (H) of the offset. The number shown at the intersection of row L1 and column H is L1. Place the second bending mark L1 inches from the first bending mark.
5. Bend the conduit.

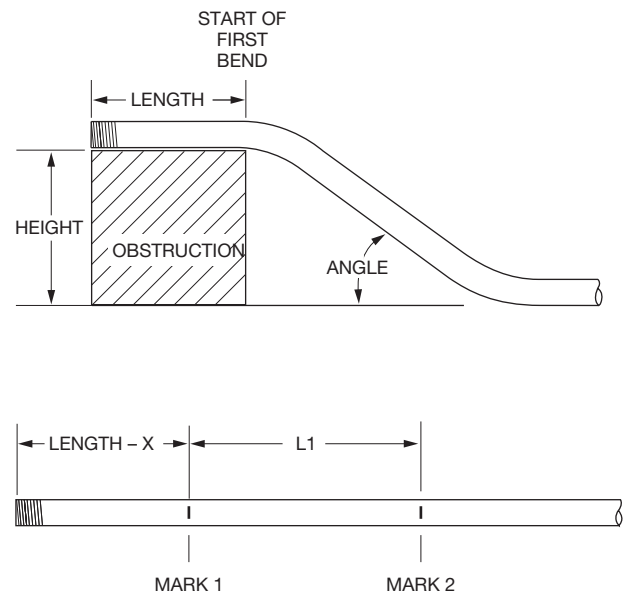

Additional Bending Instructions (cont'd)

Working Toward an Obstruction

1. Select the size and type of conduit. Measure the height of the obstruction and the distance labeled **LENGTH TO END OF SECOND BEND**. Determine the angle to be used.
2. Find the table that corresponds to the size and type of conduit selected in Step 1.
3. Under the column labeled **ANGLE**, find the appropriate angle. Find the row labeled **Z**. In the row at the top of the page, find the height (**H**) of the offset. The number shown at the intersection of the **Z** row and the **H** column is **Z**. Subtract **Z** from **LENGTH TO THE END OF SECOND BEND**. Place the first bending mark this distance from the end of the conduit.
4. In the same column, find the row labeled **L1**. Place the second bending mark **L1** inches from the first bending mark.
5. Bend the conduit.

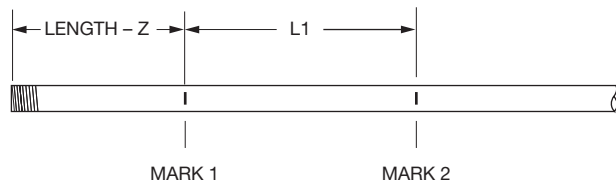
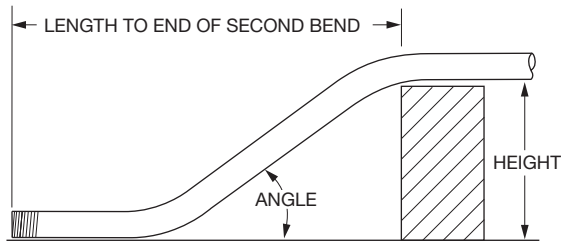

THREE-BEND SADDLE

1. Select the size and type of conduit. Measure the height of the obstruction and the distance from the end of the conduit to the center (**LENGTH TO CENTER**) of the bend. Determine the angle to be used.
2. Find the table that corresponds to the size and type of conduit selected in Step 1.
3. Under the column labeled **ANGLE**, find the appropriate angle. Find the row labeled **Z**. In the row at the top of the page, find the height (**H**) of the offset. The number shown at the intersection of the **Z** row and the appropriate **H** column is **Z**. Subtract **Z** from the **LENGTH TO CENTER**. Place the first bending mark this distance from the end of the conduit.
4. In the same column, find the row labeled **L1**. Place the second bending mark **L1** inches from the first bending mark.
5. In the same column, find the row labeled **L2**. Place the third bending mark **L2** inches from the second bending mark.
6. Bend the conduit.

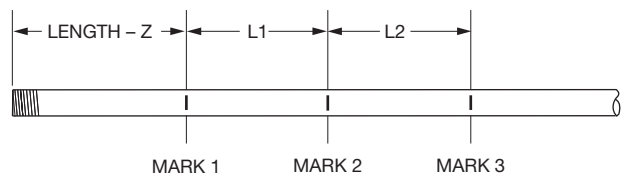
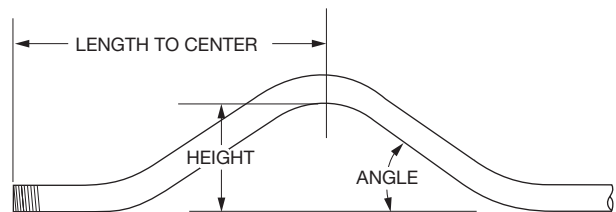

Additional Bending Instructions (cont'd)

FOUR-BEND SADDLE

1. Select the size and type of conduit. Measure the height of the obstruction, the distance labeled **LENGTH**, and the distance labeled **STRAIGHT SECTION**. Determine the angle to be used.
2. Find the table that corresponds to the size and type of conduit selected in Step 1.
3. Under the column labeled **ANGLE**, find the appropriate angle. Find the row labeled **Z**. In the row at the top of the page, find the height (**H**) of the offset. The number shown at the intersection of the **Z** row and the appropriate **H** column is **Z**. Subtract **Z** from the **LENGTH**. Place the first bending mark this distance from the end of the conduit.
4. In the same column, find the row labeled **L1**. Place the second bending mark **L1** inches from the first bending mark.
5. In the same column, find the row labeled **L2**. Add **L2** to the **STRAIGHT SECTION**. Place the third bending mark this distance from the first bending mark.
6. Make the final bending mark **L1** inches from the third bending mark.
7. Bend the conduit.

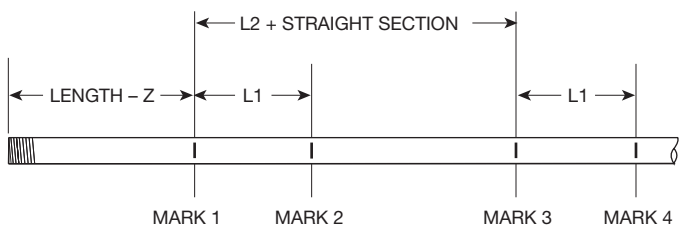
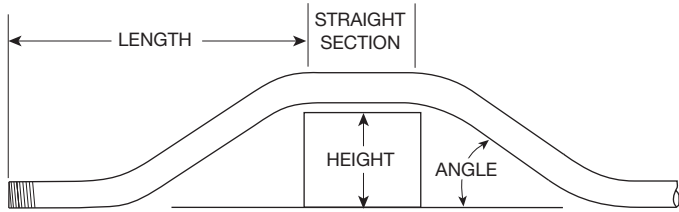

U-BENDS

1. Select the size and type of conduit. Determine the **LENGTH** and the **HEIGHT**.
2. Find the table that corresponds to the size and type of conduit selected in Step 1.
3. Under the column labeled **ANGLE**, find 90° .
4. Find the row labeled **Y**. In the row at the top of the page, find the height (**H**) that corresponds to the **LENGTH**. The number shown at the intersection of the **Y** row and the appropriate **H** column is the distance **Y**. Place the bending mark **Y** inches from the end of the conduit.
5. Find the row labeled **L1**, and go to the right to find the height (**H**) that corresponds to the **HEIGHT**.
6. The number shown at the intersection of the **L1** row and the appropriate **H** column is **L1**. Place the second bending mark **L1** inches from the first mark.
7. Bend the conduit.

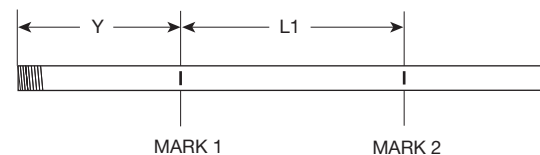
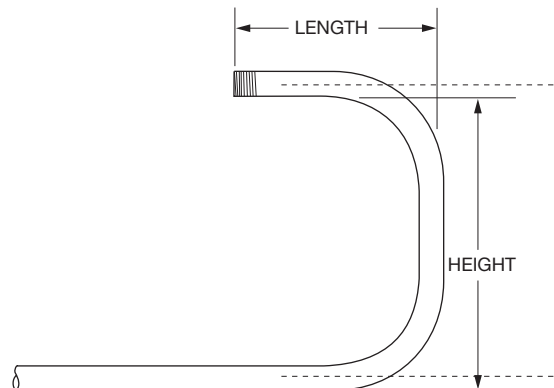

Additional Bending Tables

| | DIM | ANGLE | 2" | 4" | 6" | 8" | 10" | 12" | 15" | 18" | 24" | 36" |
|--------------------|-----|-------|-------|-------|-------|-------|-------|-------|--------|-------|-------|--------|
| 1/2" EMT | | | | | | | | | | | | |
| | Y | 15 | 3.74 | 11.47 | 19.20 | 26.92 | 34.65 | 42.38 | 53.97 | 65.56 | 88.74 | 135.11 |
| | L1 | 15 | 7.72 | 15.45 | 23.18 | 30.90 | 38.63 | 46.36 | 57.95 | 69.54 | 92.72 | 139.09 |
| | L2 | 15 | 8.94 | 16.66 | 24.39 | 32.12 | 39.84 | 47.57 | 59.16 | 70.75 | 93.94 | 140.30 |
| | Z | 15 | 10.70 | 18.16 | 25.62 | 33.09 | 40.55 | 48.02 | 59.21 | 70.41 | 92.80 | 137.59 |
| MINIMUM H = 0.84 | | | | | | | | | | | | |
| | Y | 22.5 | 1.37 | 6.60 | 11.82 | 17.05 | 22.28 | 27.50 | 35.34 | 43.18 | 58.86 | 90.22 |
| | L1 | 22.5 | 5.20 | 10.43 | 15.65 | 20.88 | 26.11 | 31.33 | 39.17 | 47.01 | 62.69 | 94.05 |
| | L2 | 22.5 | 7.02 | 12.25 | 17.48 | 22.70 | 27.93 | 33.16 | 41.00 | 48.83 | 64.51 | 95.87 |
| | Z | 22.5 | 8.68 | 13.51 | 18.34 | 23.17 | 28.00 | 32.83 | 40.07 | 47.31 | 61.80 | 90.77 |
| MINIMUM H = 1.48 | | | | | | | | | | | | |
| | Y | 30 | 0.04 | 4.04 | 8.04 | 12.04 | 16.04 | 20.04 | 26.04 | 32.04 | 44.04 | 68.04 |
| | L1 | 30 | | 7.94 | 11.94 | 15.94 | 19.94 | 23.94 | 29.94 | 35.94 | 47.94 | 71.94 |
| | L2 | 30 | | 10.37 | 14.37 | 18.37 | 22.37 | 26.37 | 32.37 | 38.37 | 50.37 | 74.37 |
| | Z | 30 | | 11.42 | 14.89 | 18.35 | 21.82 | 25.28 | 30.48 | 35.67 | 46.07 | 66.85 |
| MINIMUM H = 2.25 | | | | | | | | | | | | |
| | Y | 45 | | 1.23 | 4.05 | 6.88 | 9.71 | 12.54 | 16.78 | 21.02 | 29.51 | 46.48 |
| | L1 | 45 | | | 8.29 | 11.11 | 13.94 | 16.77 | 21.01 | 25.26 | 33.74 | 50.71 |
| | L2 | 45 | | | 11.93 | 14.76 | 17.59 | 20.42 | 24.66 | 28.90 | 37.39 | 54.36 |
| | Z | 45 | | | 11.85 | 13.85 | 15.85 | 17.85 | 20.85 | 23.85 | 29.85 | 41.85 |
| MINIMUM H = 4.14 | | | | | | | | | | | | |
| | Y | 60 | | | 1.83 | 4.14 | 6.45 | 8.76 | 12.22 | 15.69 | 22.62 | 36.47 |
| | L1 | 60 | | | | 8.74 | 11.05 | 13.36 | 16.82 | 20.29 | 27.21 | 41.07 |
| | L2 | 60 | | | | 13.60 | 15.91 | 18.22 | 21.68 | 25.14 | 32.07 | 45.93 |
| | Z | 60 | | | | 11.99 | 13.14 | 14.30 | 16.03 | 17.76 | 21.22 | 28.15 |
| MINIMUM H = 6.38 | | | | | | | | | | | | |
| | Y | 90 | | | | 1.00 | 3.00 | 5.00 | 8.00 | 11.00 | 17.00 | 29.00 |
| | L1 | 90 | | | | | | 10.01 | 13.01 | 16.01 | 22.01 | 34.01 |
| | L2 | 90 | | | | | | 17.30 | 20.30 | 23.30 | 29.30 | 41.30 |
| | Z | 90 | | | | | | 11.29 | 11.29 | 11.29 | 11.29 | 11.29 |
| MINIMUM H = 11.29 | | | | | | | | | | | | |
| 3/4" EMT | | | | | | | | | | | | |
| | Y | 15 | 2.35 | 10.07 | 17.80 | 25.53 | 33.26 | 40.98 | 52.58 | 64.17 | 87.35 | 133.71 |
| | L1 | 15 | 7.72 | 15.45 | 23.17 | 30.90 | 38.63 | 46.36 | 57.95 | 69.54 | 92.72 | 139.08 |
| | L2 | 15 | 9.17 | 16.90 | 24.62 | 32.35 | 40.08 | 47.81 | 59.40 | 70.99 | 94.17 | 140.54 |
| | Z | 15 | 11.79 | 19.26 | 26.72 | 34.19 | 41.65 | 49.11 | 60.31 | 71.51 | 93.90 | 138.68 |
| MINIMUM H = 1.12 | | | | | | | | | | | | |
| | Y | 22.5 | 0.05 | 5.28 | 10.50 | 15.73 | 20.95 | 26.18 | 34.02 | 41.86 | 57.54 | 88.90 |
| | L1 | 22.5 | 5.20 | 10.42 | 15.65 | 20.88 | 26.10 | 31.33 | 39.17 | 47.01 | 62.69 | 94.04 |
| | L2 | 22.5 | 7.37 | 12.60 | 17.83 | 23.05 | 28.28 | 33.50 | 41.34 | 49.18 | 64.86 | 96.22 |
| | Z | 22.5 | 9.90 | 14.73 | 19.56 | 24.39 | 29.22 | 34.04 | 41.29 | 48.53 | 63.02 | 91.99 |
| MINIMUM H = 1.94 | | | | | | | | | | | | |
| | Y | 30 | | 2.72 | 6.72 | 10.72 | 14.72 | 18.72 | 24.72 | 30.72 | 42.72 | 66.72 |
| | L1 | 30 | | 7.93 | 11.93 | 15.93 | 19.93 | 23.93 | 29.93 | 35.93 | 47.93 | 71.93 |
| | L2 | 30 | | 10.83 | 14.83 | 18.83 | 22.83 | 26.83 | 32.83 | 38.83 | 50.83 | 74.83 |
| | Z | 30 | | 12.77 | 16.23 | 19.70 | 23.16 | 26.62 | 31.82 | 37.02 | 47.41 | 68.19 |
| MINIMUM H = 2.92 | | | | | | | | | | | | |
| | Y | 45 | | | 2.67 | 5.50 | 8.33 | 11.15 | 15.40 | 19.64 | 28.12 | 45.09 |
| | L1 | 45 | | | 8.25 | 11.08 | 13.90 | 16.73 | 20.97 | 25.22 | 33.70 | 50.67 |
| | L2 | 45 | | | 12.60 | 15.43 | 18.25 | 21.08 | 25.33 | 29.57 | 38.05 | 55.02 |
| | Z | 45 | | | 13.46 | 15.46 | 17.46 | 19.46 | 22.46 | 25.46 | 31.46 | 43.46 |
| MINIMUM H = 5.27 | | | | | | | | | | | | |
| | Y | 60 | | | 0.33 | 2.64 | 4.95 | 7.26 | 10.72 | 14.18 | 21.11 | 34.97 |
| | L1 | 60 | | | | | 10.95 | 13.26 | 16.72 | 20.19 | 27.12 | 40.97 |
| | L2 | 60 | | | | | 16.75 | 19.06 | 22.53 | 25.99 | 32.92 | 46.78 |
| | Z | 60 | | | | | 15.04 | 16.20 | 17.93 | 19.66 | 23.12 | 30.05 |
| MINIMUM H = 8.03 | | | | | | | | | | | | |
| | Y | 90 | | | | | 1.13 | 3.13 | 6.13 | 9.13 | 15.13 | 27.13 |
| | L1 | 90 | | | | | | | *12.62 | 15.62 | 21.62 | 33.62 |
| | L2 | 90 | | | | | | | 21.32 | 24.32 | 30.32 | 42.32 |
| | Z | 90 | | | | | | | 13.95 | 13.95 | 13.95 | 13.95 |
| MINIMUM H = 13.95* | | | | | | | | | | | | |

*MINIMUM H on U-bends = 16.25 on EMT single shoe

Additional Bending Tables (cont'd)

| | DIM | ANGLE | 2" | 4" | 6" | 8" | 10" | 12" | 15" | 18" | 24" | 36" |
|-------------------|-----|-------|-------|-------|-------|-------|-------|-------|-------|-------|-------|--------|
| 1" EMT | | | | | | | | | | | | |
| | Y | 15 | 1.35 | 9.07 | 16.80 | 24.53 | 32.26 | 39.98 | 51.57 | 63.16 | 86.35 | 132.71 |
| | L1 | 15 | 7.72 | 15.44 | 23.17 | 30.90 | 38.63 | 46.35 | 57.95 | 69.54 | 92.72 | 139.08 |
| | L2 | 15 | 9.54 | 17.26 | 24.99 | 32.72 | 40.45 | 48.17 | 59.76 | 71.36 | 94.54 | 140.90 |
| | Z | 15 | 12.51 | 19.98 | 27.44 | 34.91 | 42.37 | 49.83 | 61.03 | 72.23 | 94.62 | 139.40 |
| MINIMUM H = 1.31 | | | | | | | | | | | | |
| | Y | 22.5 | | 4.33 | 9.56 | 14.78 | 20.01 | 25.24 | 33.07 | 40.91 | 56.59 | 87.95 |
| | L1 | 22.5 | | 10.42 | 15.64 | 20.87 | 26.10 | 31.32 | 39.16 | 47.00 | 62.68 | 94.04 |
| | L2 | 22.5 | | 13.15 | 18.37 | 23.60 | 28.82 | 34.05 | 41.89 | 49.73 | 65.41 | 96.77 |
| | Z | 22.5 | | 15.64 | 20.47 | 25.30 | 30.13 | 34.96 | 42.20 | 49.44 | 63.93 | 92.90 |
| MINIMUM H = 2.29 | | | | | | | | | | | | |
| | Y | 30 | | 1.75 | 5.75 | 9.75 | 13.75 | 17.75 | 23.75 | 29.75 | 41.75 | 65.75 |
| | L | 30 | | 7.91 | 11.91 | 15.91 | 19.91 | 23.91 | 29.91 | 35.91 | 47.91 | 71.91 |
| | L2 | 30 | | 11.55 | 15.55 | 19.55 | 23.55 | 27.55 | 33.55 | 39.55 | 51.55 | 75.55 |
| | Z | 30 | | 13.87 | 17.34 | 20.80 | 24.27 | 27.73 | 32.92 | 28.12 | 48.51 | 69.30 |
| MINIMUM H = 3.47 | | | | | | | | | | | | |
| | Y | 45 | | | 1.56 | 4.39 | 7.22 | 10.05 | 14.29 | 18.53 | 27.02 | 43.99 |
| | L1 | 45 | | | | 11.01 | 13.84 | 16.67 | 20.91 | 25.16 | 33.64 | 50.61 |
| | L2 | 45 | | | | 16.47 | 19.30 | 22.13 | 26.37 | 30.62 | 39.10 | 56.07 |
| | Z | 45 | | | | 16.98 | 18.98 | 20.98 | 23.98 | 26.98 | 32.98 | 44.98 |
| MINIMUM H = 6.35 | | | | | | | | | | | | |
| | Y | 60 | | | | 1.33 | 3.64 | 5.95 | 9.42 | 12.88 | 19.81 | 33.67 |
| | L1 | 60 | | | | | 10.80 | 13.11 | 16.57 | 20.04 | 26.97 | 40.82 |
| | L2 | 60 | | | | | 18.08 | 20.39 | 23.85 | 27.32 | 34.24 | 48.10 |
| | Z | 60 | | | | | 17.02 | 18.17 | 19.91 | 21.64 | 25.10 | 32.03 |
| MINIMUM H = 9.74 | | | | | | | | | | | | |
| | Y | 90 | | | | | | 1.25 | 4.25 | 7.25 | 13.25 | 25.25 |
| | L1 | 90 | | | | | | | | 15.02 | 21.02 | 33.02 |
| | L2 | 90 | | | | | | | | 25.93 | 31.93 | 43.93 |
| | Z | 90 | | | | | | | | 17.12 | 17.12 | 17.12 |
| MINIMUM H = 17.12 | | | | | | | | | | | | |
| 1-1/4" EMT | | | | | | | | | | | | |
| | Y | 15 | 0.26 | 7.99 | 15.72 | 23.45 | 31.17 | 38.90 | 50.49 | 62.08 | 85.27 | 131.63 |
| | L1 | 15 | 7.71 | 15.44 | 23.17 | 30.90 | 38.62 | 46.35 | 57.94 | 69.53 | 92.72 | 139.08 |
| | L2 | 15 | 10.07 | 17.80 | 25.52 | 33.25 | 40.98 | 48.71 | 60.30 | 71.89 | 95.07 | 141.44 |
| | Z | 15 | 13.20 | 20.66 | 28.12 | 35.59 | 43.05 | 50.52 | 61.71 | 72.91 | 95.30 | 140.09 |
| MINIMUM H = 1.48 | | | | | | | | | | | | |
| | Y | 22.5 | | 3.33 | 8.55 | 13.78 | 19.01 | 24.23 | 32.07 | 39.91 | 55.59 | 86.95 |
| | L1 | 22.5 | | 10.41 | 15.63 | 20.86 | 26.09 | 31.31 | 39.15 | 46.99 | 62.67 | 94.03 |
| | L2 | 22.5 | | 13.94 | 19.17 | 24.40 | 29.62 | 34.85 | 42.69 | 50.53 | 66.21 | 97.56 |
| | Z | 22.5 | | 16.60 | 21.43 | 26.26 | 31.09 | 35.91 | 43.16 | 50.40 | 64.89 | 93.86 |
| MINIMUM H = 2.66 | | | | | | | | | | | | |
| | Y | 30 | | 0.72 | 4.72 | 8.72 | 12.72 | 16.72 | 22.72 | 28.72 | 40.72 | 64.72 |
| | L1 | 30 | | | 11.89 | 15.89 | 19.89 | 23.89 | 29.89 | 35.89 | 47.89 | 71.89 |
| | L2 | 30 | | | 16.61 | 20.61 | 24.61 | 28.61 | 34.61 | 40.61 | 52.61 | 76.61 |
| | Z | 30 | | | 18.58 | 22.04 | 25.51 | 28.97 | 34.17 | 39.37 | 49.76 | 70.54 |
| MINIMUM H = 4.09 | | | | | | | | | | | | |
| | Y | 45 | | | 0.33 | 3.15 | 5.98 | 8.81 | 13.05 | 17.30 | 25.78 | 42.75 |
| | L1 | 45 | | | | 10.93 | 13.75 | 16.58 | 20.83 | 25.07 | 33.55 | 50.52 |
| | L2 | 45 | | | | 18.00 | 20.83 | 23.66 | 27.90 | 32.14 | 40.63 | 57.60 |
| | Z | 45 | | | | 18.82 | 20.82 | 22.82 | 25.82 | 28.82 | 34.82 | 46.82 |
| MINIMUM H = 7.65 | | | | | | | | | | | | |
| | Y | 60 | | | | | 2.11 | 4.42 | 7.89 | 11.35 | 18.28 | 32.14 |
| | L1 | 60 | | | | | | 12.89 | 16.35 | 19.82 | 26.74 | 40.60 |
| | L2 | 60 | | | | | | 22.32 | 25.79 | 29.25 | 36.18 | 50.04 |
| | Z | 60 | | | | | | 20.69 | 22.42 | 24.16 | 27.62 | 34.55 |
| MINIMUM H = 11.92 | | | | | | | | | | | | |
| | Y | 90 | | | | | | | 1.88 | 4.88 | 10.88 | 22.88 |
| | L1 | 90 | | | | | | | | | 20.13 | 32.13 |
| | L2 | 90 | | | | | | | | | 34.29 | 46.29 |
| | Z | 90 | | | | | | | | | 21.38 | 21.38 |
| MINIMUM H = 21.38 | | | | | | | | | | | | |

Additional Bending Tables (cont'd)

| | DIM | ANGLE | 2" | 4" | 6" | 8" | 10" | 12" | 15" | 18" | 24" | 36" |
|-------------------|-----|-------|-------|-------|-------|-------|-------|-------|-------|-------|-------|--------|
| 1-1/2" EMT | | | | | | | | | | | | |
| | Y | 15 | | 6.26 | 13.99 | 21.72 | 29.44 | 37.17 | 48.76 | 60.35 | 83.53 | 129.90 |
| | L1 | 15 | 7.71 | 15.44 | 23.17 | 30.90 | 38.62 | 46.35 | 57.94 | 69.53 | 92.72 | 139.08 |
| | L2 | 15 | 9.95 | 17.68 | 25.40 | 33.13 | 40.86 | 48.58 | 60.18 | 71.77 | 94.95 | 141.31 |
| | Z | 15 | 14.42 | 21.88 | 29.35 | 36.81 | 44.28 | 51.74 | 62.94 | 74.13 | 96.53 | 141.31 |
| MINIMUM H = 1.81 | | | | | | | | | | | | |
| | Y | 22.5 | | 1.77 | 7.00 | 12.22 | 17.45 | 22.68 | 30.52 | 38.36 | 54.03 | 85.39 |
| | L1 | 22.5 | | 10.41 | 15.64 | 20.86 | 26.09 | 31.31 | 39.15 | 46.99 | 62.67 | 94.03 |
| | L2 | 22.5 | | 13.76 | 18.98 | 24.21 | 29.44 | 34.66 | 42.50 | 50.34 | 66.02 | 97.38 |
| | Z | 22.5 | | 17.76 | 22.59 | 27.42 | 32.25 | 37.07 | 44.32 | 51.56 | 66.04 | 95.02 |
| MINIMUM H = 3.11 | | | | | | | | | | | | |
| | Y | 30 | | | 3.26 | 7.26 | 11.26 | 15.26 | 21.26 | 27.26 | 39.26 | 63.26 |
| | L1 | 30 | | | 11.90 | 15.90 | 19.90 | 23.90 | 29.90 | 35.90 | 47.90 | 71.90 |
| | L2 | 30 | | | 16.36 | 20.36 | 24.36 | 28.36 | 34.36 | 40.36 | 52.36 | 76.36 |
| | Z | 30 | | | 19.67 | 23.14 | 26.60 | 30.07 | 35.26 | 40.46 | 50.85 | 71.64 |
| MINIMUM H = 4.64 | | | | | | | | | | | | |
| | Y | 45 | | | | 1.84 | 4.67 | 7.50 | 11.74 | 15.98 | 24.47 | 41.44 |
| | L1 | 45 | | | | | 13.78 | 16.60 | 20.85 | 25.09 | 33.57 | 50.54 |
| | L2 | 45 | | | | | 20.47 | 23.30 | 27.55 | 31.79 | 40.27 | 57.24 |
| | Z | 45 | | | | | 21.78 | 23.78 | 26.78 | 29.78 | 35.78 | 47.78 |
| MINIMUM H = 8.33 | | | | | | | | | | | | |
| | Y | 60 | | | | | 0.91 | 3.22 | 6.68 | 10.15 | 17.07 | 30.93 |
| | L1 | 60 | | | | | | | 16.40 | 19.87 | 26.80 | 40.65 |
| | L2 | 60 | | | | | | | 25.34 | 28.80 | 35.73 | 49.58 |
| | Z | 60 | | | | | | | 23.22 | 24.95 | 28.42 | 35.34 |
| MINIMUM H = 12.61 | | | | | | | | | | | | |
| | Y | 90 | | | | | | | 0.89 | 3.89 | 9.89 | 21.89 |
| | L1 | 90 | | | | | | | | | 20.34 | 32.34 |
| | L2 | 90 | | | | | | | | | 33.74 | 45.74 |
| | Z | 90 | | | | | | | | | 21.77 | 21.77 |
| MINIMUM H = 21.77 | | | | | | | | | | | | |
| 2" EMT | | | | | | | | | | | | |
| | Y | 15 | | 5.15 | 12.87 | 20.60 | 28.33 | 36.05 | 47.65 | 59.24 | 82.42 | 128.78 |
| | L1 | 15 | 7.71 | 15.44 | 23.17 | 30.90 | 38.62 | 46.35 | 57.94 | 69.53 | 92.71 | 139.08 |
| | L2 | 15 | 10.19 | 17.92 | 25.64 | 33.37 | 41.10 | 48.83 | 60.42 | 72.01 | 95.19 | 141.56 |
| | Z | 15 | 14.77 | 22.24 | 29.70 | 37.17 | 44.63 | 52.10 | 63.29 | 74.49 | 96.88 | 141.66 |
| MINIMUM H = 1.89 | | | | | | | | | | | | |
| | Y | 22.5 | | 0.88 | 6.11 | 11.33 | 16.56 | 21.79 | 29.62 | 37.46 | 53.14 | 84.50 |
| | L1 | 22.5 | | 10.40 | 15.63 | 20.86 | 26.08 | 31.31 | 39.15 | 46.99 | 62.67 | 94.02 |
| | L2 | 22.5 | | 14.12 | 19.35 | 24.57 | 29.80 | 35.02 | 42.86 | 50.70 | 66.38 | 97.74 |
| | Z | 22.5 | | 18.24 | 23.07 | 27.90 | 32.73 | 37.55 | 44.80 | 52.04 | 66.52 | 95.50 |
| MINIMUM H = 3.28 | | | | | | | | | | | | |
| | Y | 30 | | | 2.45 | 6.45 | 10.45 | 14.45 | 20.45 | 26.45 | 38.45 | 62.45 |
| | L1 | 30 | | | 11.88 | 15.88 | 19.88 | 23.88 | 29.88 | 35.88 | 47.88 | 71.88 |
| | L2 | 30 | | | 16.84 | 20.84 | 24.84 | 28.84 | 34.84 | 40.84 | 52.84 | 76.84 |
| | Z | 30 | | | 20.28 | 23.75 | 27.21 | 30.67 | 35.87 | 41.07 | 51.46 | 72.24 |
| MINIMUM H = 4.94 | | | | | | | | | | | | |
| | Y | 45 | | | | 1.02 | 3.85 | 6.68 | 10.92 | 15.16 | 23.65 | 40.62 |
| | L1 | 45 | | | | | 13.74 | 16.56 | 20.81 | 25.05 | 33.53 | 50.50 |
| | L2 | 45 | | | | | 21.16 | 23.99 | 28.24 | 32.48 | 40.96 | 57.93 |
| | Z | 45 | | | | | 22.66 | 24.66 | 27.66 | 30.66 | 36.66 | 48.66 |
| MINIMUM H = 8.95 | | | | | | | | | | | | |
| | Y | 60 | | | | | 0.00 | 2.31 | 5.77 | 9.23 | 16.16 | 30.02 |
| | L1 | 60 | | | | | | | 16.30 | 19.77 | 26.70 | 40.55 |
| | L2 | 60 | | | | | | | 26.21 | 29.67 | 36.60 | 50.46 |
| | Z | 60 | | | | | | | 24.40 | 26.14 | 29.60 | 36.53 |
| MINIMUM H = 13.63 | | | | | | | | | | | | |
| | Y | 90 | | | | | | | | 2.62 | 8.62 | 20.62 |
| | L1 | 90 | | | | | | | | | 19.94 | 31.94 |
| | L2 | 90 | | | | | | | | | 34.80 | 46.80 |
| | Z | 90 | | | | | | | | | 23.74 | 23.74 |
| MINIMUM H = 23.74 | | | | | | | | | | | | |

Additional Bending Tables (cont'd)

| | DIM | ANGLE | 2" | 4" | 6" | 8" | 10" | 12" | 15" | 18" | 24" | 36" |
|---|-----|-------|-------|-------|-------|-------|-------|-------|--------|-------|-------|--------|
| 1/2" IMC, Rigid, and 40 Mil PVC-Coated Rigid | | | | | | | | | | | | |
| | Y | 15 | 3.03 | 10.76 | 18.48 | 26.21 | 33.94 | 41.67 | 53.26 | 64.85 | 88.03 | 134.39 |
| | L1 | 15 | 7.72 | 15.45 | 23.18 | 30.90 | 38.63 | 46.36 | 57.95 | 69.54 | 92.72 | 139.09 |
| | L2 | 15 | 8.87 | 16.59 | 24.32 | 32.05 | 39.78 | 47.50 | 59.10 | 70.69 | 93.87 | 140.23 |
| | Z | 15 | 11.12 | 18.58 | 26.05 | 33.51 | 40.97 | 48.44 | 59.63 | 70.83 | 93.22 | 138.01 |
| MINIMUM H = 0.95 | | | | | | | | | | | | |
| | Y | 22.5 | .77 | 5.98 | 11.21 | 16.44 | 21.66 | 26.89 | 34.73 | 42.57 | 58.25 | 89.60 |
| | L1 | 22.5 | 5.20 | 10.43 | 15.66 | 20.88 | 26.11 | 31.34 | 39.17 | 47.01 | 62.69 | 94.05 |
| | L2 | 22.5 | 6.92 | 12.15 | 17.38 | 22.60 | 27.83 | 33.06 | 40.89 | 48.73 | 64.41 | 95.77 |
| | Z | 22.5 | 9.07 | 13.90 | 18.73 | 23.56 | 28.38 | 33.21 | 40.46 | 47.70 | 62.18 | 91.15 |
| MINIMUM H = 1.62 | | | | | | | | | | | | |
| | Y | 30 | | 3.49 | 7.49 | 11.49 | 15.49 | 19.49 | 25.49 | 31.49 | 43.49 | 67.49 |
| | L1 | 30 | | 7.95 | 11.95 | 15.95 | 19.95 | 23.95 | 29.95 | 35.95 | 47.95 | 71.95 |
| | L2 | 30 | | 10.24 | 14.24 | 18.24 | 22.24 | 26.24 | 32.24 | 38.24 | 50.24 | 74.24 |
| | Z | 30 | | 11.78 | 15.24 | 18.70 | 22.17 | 25.63 | 30.83 | 36.02 | 46.42 | 67.20 |
| MINIMUM H = 2.42 | | | | | | | | | | | | |
| | Y | 45 | | | 3.59 | 6.41 | 9.23 | 12.06 | 16.30 | 20.55 | 29.03 | 46.00 |
| | L1 | 45 | | | 8.30 | 11.13 | 13.95 | 16.78 | 21.02 | 25.27 | 33.75 | 50.72 |
| | L2 | 45 | | | 11.74 | 14.57 | 17.39 | 20.22 | 24.46 | 28.71 | 37.19 | 54.16 |
| | Z | 45 | | | 12.13 | 14.13 | 16.13 | 18.13 | 21.13 | 24.13 | 30.13 | 42.13 |
| MINIMUM H = 4.33 | | | | | | | | | | | | |
| | Y | 60 | | | 1.42 | 3.73 | 6.04 | 8.34 | 11.81 | 15.27 | 22.20 | 36.06 |
| | L1 | 60 | | | | 8.77 | 11.08 | 13.39 | 16.85 | 20.31 | 27.24 | 41.10 |
| | L2 | 60 | | | | 13.35 | 15.66 | 17.97 | 21.44 | 24.90 | 31.83 | 45.69 |
| | Z | 60 | | | | 12.18 | 13.33 | 14.49 | 16.22 | 17.95 | 21.41 | 28.34 |
| MINIMUM H = 6.55 | | | | | | | | | | | | |
| | Y | 90 | | | | .71 | 2.71 | 4.71 | 7.71 | 10.71 | 16.70 | 28.70 |
| | L1 | 90 | | | | | | 10.12 | 13.12 | 16.12 | 22.12 | 34.12 |
| | L2 | 90 | | | | | | 17.00 | 20.00 | 23.00 | 29.00 | 41.00 |
| | Z | 90 | | | | | | 11.26 | 11.26 | 11.26 | 11.26 | 11.26 |
| MINIMUM H = 11.26 | | | | | | | | | | | | |
| 3/4" IMC, Rigid, and 40 Mil PVC-Coated Rigid | | | | | | | | | | | | |
| | Y | 15 | 1.86 | 9.58 | 17.31 | 25.04 | 32.77 | 40.49 | 52.08 | 63.68 | 86.86 | 133.22 |
| | L1 | 15 | 7.72 | 15.45 | 23.17 | 30.90 | 38.63 | 46.36 | 57.95 | 69.54 | 92.72 | 139.08 |
| | L2 | 15 | 9.19 | 16.91 | 24.64 | 32.37 | 40.09 | 47.82 | 59.41 | 71.00 | 94.19 | 140.55 |
| | Z | 15 | 12.06 | 19.53 | 26.89 | 34.46 | 41.92 | 49.38 | 60.58 | 71.78 | 94.17 | 138.95 |
| MINIMUM H = 1.19 | | | | | | | | | | | | |
| | Y | 22.5 | | 4.85 | 10.08 | 15.31 | 20.53 | 25.76 | 33.60 | 41.44 | 57.12 | 88.47 |
| | L1 | 22.5 | | 10.42 | 15.65 | 20.88 | 26.10 | 31.33 | 39.17 | 47.01 | 62.69 | 94.04 |
| | L2 | 22.5 | | 12.62 | 17.85 | 23.08 | 28.30 | 33.53 | 41.37 | 49.21 | 64.89 | 96.24 |
| | Z | 22.5 | | 15.01 | 19.84 | 24.67 | 29.49 | 34.32 | 41.57 | 48.81 | 63.29 | 92.26 |
| MINIMUM H = 2.05 | | | | | | | | | | | | |
| | Y | 30 | | 2.33 | 6.33 | 10.33 | 14.33 | 18.33 | 24.33 | 30.33 | 42.33 | 66.33 |
| | L1 | 30 | | 7.93 | 11.93 | 15.93 | 19.93 | 23.93 | 29.93 | 35.93 | 47.93 | 71.93 |
| | L2 | 30 | | 10.86 | 14.86 | 18.86 | 22.86 | 26.86 | 32.86 | 38.86 | 50.86 | 74.86 |
| | Z | 30 | | 13.05 | 16.52 | 19.98 | 23.45 | 26.91 | 32.11 | 37.30 | 47.70 | 68.48 |
| MINIMUM H = 3.06 | | | | | | | | | | | | |
| | Y | 45 | | | 2.31 | 5.13 | 7.96 | 10.79 | 15.03 | 19.28 | 27.76 | 44.73 |
| | L1 | 45 | | | 8.24 | 11.07 | 13.90 | 16.73 | 20.97 | 25.21 | 33.70 | 50.67 |
| | L2 | 45 | | | 12.64 | 15.47 | 18.30 | 21.13 | 25.37 | 29.61 | 38.10 | 55.07 |
| | Z | 45 | | | 13.76 | 15.76 | 17.76 | 19.76 | 22.76 | 25.76 | 31.76 | 43.76 |
| MINIMUM H = 5.49 | | | | | | | | | | | | |
| | Y | 60 | | | | 2.28 | 4.59 | 6.90 | 10.36 | 13.83 | 20.75 | 34.61 |
| | L1 | 60 | | | | | 10.94 | 13.25 | 16.72 | 20.18 | 27.11 | 40.97 |
| | L2 | 60 | | | | | 16.81 | 19.12 | 22.58 | 26.05 | 32.98 | 46.83 |
| | Z | 60 | | | | | 15.36 | 16.52 | 18.25 | 19.88 | 23.45 | 30.38 |
| MINIMUM H = 8.31 | | | | | | | | | | | | |
| | Y | 90 | | | | | .76 | 2.76 | 5.76 | 8.76 | 14.76 | 26.76 |
| | L1 | 90 | | | | | | | *12.60 | 15.60 | 21.60 | 33.60 |
| | L2 | 90 | | | | | | | 21.39 | 24.39 | 30.39 | 42.39 |
| | Z | 90 | | | | | | | 14.33 | 14.33 | 14.33 | 14.33 |
| MINIMUM H = 14.33* | | | | | | | | | | | | |

*MINIMUM H on U-bends = 16.62 on single shoes

Additional Bending Tables (cont'd)

| | DIM | ANGLE | 2" | 4" | 6" | 8" | 10" | 12" | 15" | 18" | 24" | 36" |
|---|-----|-------|-------|-------|-------|-------|-------|-------|-------|-------|-------|--------|
| 1" IMC, Rigid, and 40 Mil PVC-Coated Rigid | | | | | | | | | | | | |
| | Y | 15 | 1.08 | 8.81 | 16.52 | 24.25 | 31.97 | 39.70 | 51.29 | 62.88 | 86.07 | 132.43 |
| | L1 | 15 | 7.72 | 15.44 | 23.17 | 30.90 | 38.63 | 46.35 | 57.94 | 69.54 | 92.72 | 139.08 |
| | L2 | 15 | 9.59 | 17.32 | 25.04 | 32.77 | 40.50 | 48.23 | 59.82 | 71.41 | 94.59 | 140.95 |
| | Z | 15 | 12.53 | 20.00 | 27.46 | 34.93 | 42.39 | 49.86 | 61.05 | 72.25 | 94.64 | 139.43 |
| MINIMUM H = 1.31 | | | | | | | | | | | | |
| | Y | 22.5 | | 4.13 | 9.35 | 14.58 | 19.81 | 25.03 | 32.87 | 40.71 | 56.39 | 87.75 |
| | L1 | 22.5 | | 10.42 | 15.64 | 20.87 | 26.09 | 31.32 | 39.16 | 47.00 | 62.68 | 94.04 |
| | L2 | 22.5 | | 13.22 | 18.45 | 23.68 | 28.90 | 34.13 | 41.97 | 49.81 | 65.49 | 96.84 |
| | Z | 22.5 | | 15.69 | 20.52 | 25.35 | 30.18 | 35.01 | 42.25 | 49.49 | 63.98 | 92.95 |
| MINIMUM H = 2.31 | | | | | | | | | | | | |
| | Y | 30 | | 1.58 | 5.58 | 9.58 | 13.58 | 17.58 | 23.58 | 29.58 | 41.58 | 65.58 |
| | L1 | 30 | | 7.91 | 11.91 | 15.91 | 19.91 | 23.91 | 29.91 | 35.91 | 47.91 | 71.91 |
| | L2 | 30 | | 11.66 | 15.66 | 19.66 | 23.66 | 27.66 | 33.66 | 39.66 | 51.66 | 75.66 |
| | Z | 30 | | 13.95 | 17.41 | 20.88 | 24.34 | 27.81 | 33.00 | 38.20 | 48.59 | 69.38 |
| MINIMUM H = 3.51 | | | | | | | | | | | | |
| | Y | 45 | | | 1.42 | 4.24 | 7.06 | 9.89 | 14.14 | 18.38 | 26.86 | 43.83 |
| | L1 | 45 | | | | 11.01 | 13.83 | 16.66 | 20.91 | 25.15 | 33.63 | 50.60 |
| | L2 | 45 | | | | 16.62 | 19.45 | 22.28 | 26.52 | 30.76 | 39.25 | 56.22 |
| | Z | 45 | | | | 17.11 | 19.11 | 21.11 | 24.11 | 27.11 | 33.11 | 45.11 |
| MINIMUM H = 6.44 | | | | | | | | | | | | |
| | Y | 60 | | | | 1.17 | 3.48 | 5.79 | 9.25 | 12.71 | 19.64 | 33.49 |
| | L1 | 60 | | | | | 10.78 | 13.09 | 16.55 | 20.02 | 26.94 | 40.80 |
| | L2 | 60 | | | | | 18.27 | 20.58 | 24.04 | 27.50 | 34.43 | 48.29 |
| | Z | 60 | | | | | 17.22 | 18.37 | 20.11 | 21.84 | 25.30 | 32.23 |
| MINIMUM H = 9.91 | | | | | | | | | | | | |
| | Y | 90 | | | | | | 1.01 | 4.01 | 7.01 | 13.01 | 25.01 |
| | L1 | 90 | | | | | | | | 14.93 | 20.93 | 32.93 |
| | L2 | 90 | | | | | | | | 26.16 | 32.16 | 44.16 |
| | Z | 90 | | | | | | | | 17.49 | 17.49 | 17.49 |
| MINIMUM H = 17.49 | | | | | | | | | | | | |
| 1-1/4" IMC, Rigid, and 40 Mil PVC-Coated Rigid | | | | | | | | | | | | |
| | Y | 15 | | 7.15 | 14.87 | 22.60 | 30.33 | 38.06 | 49.65 | 61.24 | 84.42 | 130.78 |
| | L1 | 15 | 7.71 | 15.44 | 23.17 | 30.90 | 38.62 | 46.35 | 57.94 | 69.53 | 92.72 | 139.08 |
| | L2 | 15 | 10.07 | 17.80 | 25.53 | 33.25 | 40.98 | 48.71 | 60.30 | 71.89 | 95.07 | 141.44 |
| | Z | 15 | 13.77 | 21.24 | 28.70 | 36.17 | 43.63 | 51.09 | 62.29 | 73.49 | 95.88 | 140.66 |
| MINIMUM H = 1.63 | | | | | | | | | | | | |
| | Y | 22.5 | | 2.57 | 7.80 | 13.02 | 18.25 | 23.47 | 31.31 | 39.15 | 54.83 | 86.19 |
| | L1 | 22.5 | | 10.41 | 15.63 | 20.86 | 26.09 | 31.31 | 39.15 | 46.99 | 62.67 | 94.03 |
| | L2 | 22.5 | | 13.94 | 19.17 | 24.40 | 29.62 | 34.85 | 42.69 | 50.53 | 66.21 | 97.56 |
| | Z | 22.5 | | 17.18 | 22.01 | 26.84 | 31.66 | 36.49 | 43.73 | 50.98 | 65.46 | 94.43 |
| MINIMUM H = 2.88 | | | | | | | | | | | | |
| | Y | 30 | | | 4.00 | 8.00 | 12.00 | 16.00 | 22.00 | 28.00 | 40.00 | 64.00 |
| | L1 | 30 | | | 11.89 | 15.89 | 19.89 | 23.89 | 29.89 | 35.89 | 47.89 | 71.89 |
| | L2 | 30 | | | 16.61 | 20.61 | 24.61 | 28.61 | 34.61 | 40.61 | 52.61 | 76.61 |
| | Z | 30 | | | 19.16 | 22.62 | 26.09 | 29.55 | 34.75 | 39.94 | 50.33 | 71.12 |
| MINIMUM H = 4.38 | | | | | | | | | | | | |
| | Y | 45 | | | | 2.48 | 5.31 | 8.14 | 12.38 | 16.62 | 25.11 | 42.08 |
| | L1 | 45 | | | | | 13.75 | 16.58 | 20.83 | 25.07 | 33.55 | 50.52 |
| | L2 | 45 | | | | | 20.83 | 23.66 | 27.90 | 32.14 | 40.63 | 57.60 |
| | Z | 45 | | | | | 21.40 | 23.40 | 26.40 | 29.40 | 35.40 | 47.40 |
| MINIMUM H = 8.06 | | | | | | | | | | | | |
| | Y | 60 | | | | | 1.46 | 3.77 | 7.23 | 10.69 | 17.62 | 31.48 |
| | L1 | 60 | | | | | | | 16.35 | 19.82 | 26.74 | 40.60 |
| | L2 | 60 | | | | | | | 25.79 | 29.25 | 36.18 | 50.04 |
| | Z | 60 | | | | | | | 23.00 | 24.73 | 28.20 | 35.13 |
| MINIMUM H = 11.32 | | | | | | | | | | | | |
| | Y | 90 | | | | | | | 1.23 | 4.23 | 10.23 | 22.23 |
| | L1 | 90 | | | | | | | | | 20.13 | 32.13 |
| | L2 | 90 | | | | | | | | | 34.29 | 46.29 |
| | Z | 90 | | | | | | | | | 21.96 | 21.96 |
| MINIMUM H = 21.96 | | | | | | | | | | | | |

Additional Bending Tables (cont'd)

| | DIM | ANGLE | 2" | 4" | 6" | 8" | 10" | 12" | 15" | 18" | 24" | 36" |
|---|-----|-------|-------|-------|-------|-------|-------|-------|-------|-------|-------|--------|
| 1-1/2" Rigid and 40 Mil PVC-Coated Rigid | | | | | | | | | | | | |
| | Y | 15 | | 5.87 | 13.59 | 21.32 | 29.05 | 36.77 | 48.37 | 59.96 | 83.14 | 129.50 |
| | L1 | 15 | 7.71 | 15.44 | 23.17 | 20.90 | 38.62 | 46.35 | 57.94 | 69.53 | 92.72 | 139.08 |
| | L2 | 15 | 9.94 | 17.67 | 25.39 | 33.12 | 40.85 | 48.58 | 60.17 | 71.76 | 94.94 | 141.31 |
| | Z | 15 | 14.50 | 21.97 | 29.43 | 36.89 | 44.36 | 51.82 | 63.02 | 74.21 | 96.61 | 141.39 |
| MINIMUM H = 1.82 | | | | | | | | | | | | |
| | Y | 22.5 | | 1.48 | 6.71 | 11.93 | 17.16 | 22.38 | 30.22 | 38.06 | 53.74 | 85.10 |
| | L1 | 22.5 | | 10.41 | 15.64 | 20.86 | 26.09 | 31.31 | 39.15 | 46.99 | 62.67 | 94.03 |
| | L2 | 22.5 | | 13.75 | 18.97 | 24.20 | 29.43 | 34.65 | 42.49 | 50.33 | 66.01 | 97.37 |
| | Z | 22.5 | | 17.84 | 22.67 | 27.50 | 32.32 | 37.15 | 44.39 | 51.64 | 66.12 | 95.09 |
| MINIMUM H = 3.13 | | | | | | | | | | | | |
| | Y | 30 | | | 3.02 | 7.02 | 11.02 | 15.02 | 21.02 | 27.02 | 39.02 | 63.02 |
| | L1 | 30 | | | 11.90 | 15.90 | 19.90 | 23.90 | 29.90 | 35.90 | 47.90 | 71.90 |
| | L2 | 30 | | | 16.35 | 20.35 | 24.35 | 28.35 | 34.35 | 40.35 | 52.35 | 76.35 |
| | Z | 30 | | | 19.75 | 23.21 | 26.68 | 30.14 | 35.34 | 40.53 | 50.92 | 71.71 |
| MINIMUM H = 4.68 | | | | | | | | | | | | |
| | Y | 45 | | | | 1.65 | 4.48 | 7.31 | 11.55 | 15.79 | 24.28 | 41.25 |
| | L1 | 45 | | | | | 13.78 | 16.60 | 20.85 | 25.09 | 33.58 | 50.55 |
| | L2 | 45 | | | | | 20.45 | 23.28 | 27.52 | 31.77 | 40.25 | 57.22 |
| | Z | 45 | | | | | 21.84 | 23.84 | 26.84 | 29.84 | 35.84 | 47.84 |
| MINIMUM H = 8.37 | | | | | | | | | | | | |
| | Y | 60 | | | | | 0.74 | 3.05 | 6.52 | 9.98 | 16.91 | 30.76 |
| | L1 | 60 | | | | | | | 16.41 | 19.87 | 26.80 | 40.66 |
| | L2 | 60 | | | | | | | 25.31 | 28.77 | 35.70 | 49.56 |
| | Z | 60 | | | | | | | 23.28 | 25.01 | 28.47 | 35.40 |
| MINIMUM H = 12.66 | | | | | | | | | | | | |
| | Y | 90 | | | | | | | 0.75 | 3.75 | 9.75 | 21.75 |
| | L1 | 90 | | | | | | | | | 20.35 | 32.35 |
| | L2 | 90 | | | | | | | | | 33.70 | 45.70 |
| | Z | 90 | | | | | | | | | 21.80 | 21.80 |
| MINIMUM H = 21.80 | | | | | | | | | | | | |
| 2" Rigid and 40 Mil PVC-Coated Rigid | | | | | | | | | | | | |
| | Y | 15 | | 4.42 | 12.15 | 19.87 | 27.60 | 35.33 | 46.92 | 58.51 | 81.69 | 128.06 |
| | L1 | 15 | 7.71 | 15.44 | 23.17 | 30.89 | 38.62 | 46.35 | 57.94 | 69.53 | 92.71 | 139.08 |
| | L2 | 15 | 10.27 | 18.00 | 25.73 | 33.46 | 41.18 | 48.91 | 60.50 | 72.09 | 95.27 | 141.64 |
| | Z | 15 | 15.20 | 22.66 | 30.13 | 37.59 | 45.06 | 52.52 | 63.72 | 74.91 | 97.30 | 142.09 |
| MINIMUM H = 2.00 | | | | | | | | | | | | |
| | Y | 22.5 | | 0.24 | 5.47 | 10.70 | 15.92 | 21.15 | 28.99 | 36.83 | 52.51 | 83.86 |
| | L1 | 22.5 | | 10.40 | 15.63 | 20.85 | 26.08 | 31.31 | 39.15 | 46.99 | 62.66 | 94.02 |
| | L2 | 22.5 | | 14.24 | 19.47 | 24.70 | 29.92 | 35.15 | 42.99 | 50.83 | 66.51 | 97.86 |
| | Z | 22.5 | | 18.71 | 23.54 | 28.36 | 33.19 | 38.02 | 45.26 | 52.51 | 66.99 | 95.96 |
| MINIMUM H = 3.47 | | | | | | | | | | | | |
| | Y | 30 | | | 1.84 | 5.84 | 9.84 | 13.84 | 19.84 | 25.84 | 37.84 | 61.84 |
| | L1 | 30 | | | 11.88 | 15.88 | 19.88 | 23.88 | 29.88 | 35.88 | 47.88 | 71.88 |
| | L2 | 30 | | | 17.00 | 21.00 | 25.00 | 29.00 | 35.00 | 41.00 | 53.00 | 77.00 |
| | Z | 30 | | | 20.79 | 24.26 | 27.72 | 31.19 | 36.38 | 41.58 | 51.97 | 71.75 |
| MINIMUM H = 5.20 | | | | | | | | | | | | |
| | Y | 45 | | | | 0.42 | 3.25 | 6.08 | 10.32 | 14.57 | 23.05 | 40.02 |
| | L1 | 45 | | | | | 13.72 | 16.55 | 20.79 | 25.04 | 33.52 | 50.49 |
| | L2 | 45 | | | | | 21.40 | 24.23 | 28.47 | 32.72 | 41.20 | 58.17 |
| | Z | 45 | | | | | 23.26 | 25.26 | 28.26 | 31.26 | 37.26 | 49.26 |
| MINIMUM H = 9.38 | | | | | | | | | | | | |
| | Y | 60 | | | | | | 1.68 | 5.14 | 8.61 | 15.54 | 29.39 |
| | L1 | 60 | | | | | | | 16.27 | 19.73 | 26.66 | 40.52 |
| | L2 | 60 | | | | | | | 26.51 | 29.97 | 36.90 | 50.76 |
| | Z | 60 | | | | | | | 25.11 | 26.85 | 30.31 | 37.24 |
| MINIMUM H = 14.25 | | | | | | | | | | | | |
| | Y | 90 | | | | | | | | 1.87 | 7.87 | 19.87 |
| | L1 | 90 | | | | | | | | | | 31.80 |
| | L2 | 90 | | | | | | | | | | 47.16 |
| | Z | 90 | | | | | | | | | | 24.72 |
| MINIMUM H = 24.72 | | | | | | | | | | | | |

Additional Bending Tables (cont'd)

| | DIM | ANGLE | 2" | 4" | 6" | 8" | 10" | 12" | 15" | 18" | 24" | 36" |
|-------------------|-----|-------|-------|-------|-------|-------|-------|-------|-------|-------|-------|--------|
| 1-1/2" IMC | | | | | | | | | | | | |
| | Y | 15 | | 6.41 | 14.14 | 21.87 | 29.60 | 37.32 | 48.91 | 60.51 | 83.69 | 130.05 |
| | L1 | 15 | 7.71 | 15.44 | 23.17 | 30.90 | 38.62 | 46.35 | 57.94 | 69.53 | 92.72 | 139.00 |
| | L2 | 15 | 9.95 | 17.68 | 25.40 | 33.13 | 40.86 | 48.58 | 60.18 | 71.77 | 94.94 | 141.31 |
| | Z | 15 | 13.99 | 21.45 | 28.92 | 36.38 | 43.85 | 51.31 | 62.51 | 73.70 | 96.10 | 140.88 |
| MINIMUM H = 1.69 | | | | | | | | | | | | |
| | Y | 22.5 | | 2.02 | 7.24 | 12.47 | 17.69 | 22.92 | 30.76 | 38.60 | 54.28 | 85.64 |
| | L1 | 22.5 | | 10.41 | 15.64 | 20.86 | 26.09 | 31.31 | 39.15 | 46.99 | 62.67 | 94.03 |
| | L2 | 22.5 | | 13.76 | 18.98 | 24.21 | 29.44 | 34.66 | 42.50 | 50.34 | 66.02 | 97.38 |
| | Z | 22.5 | | 17.33 | 22.16 | 26.99 | 31.82 | 36.64 | 43.89 | 51.13 | 65.61 | 94.59 |
| MINIMUM H = 2.94 | | | | | | | | | | | | |
| | Y | 30 | | | 3.55 | 7.55 | 11.55 | 15.55 | 21.55 | 27.55 | 39.55 | 63.55 |
| | L1 | 30 | | | 11.90 | 15.90 | 19.90 | 23.90 | 29.90 | 35.90 | 47.90 | 71.90 |
| | L2 | 30 | | | 16.36 | 20.36 | 24.36 | 28.36 | 34.36 | 40.36 | 52.36 | 76.36 |
| | Z | 30 | | | 19.24 | 22.71 | 26.17 | 29.64 | 34.83 | 40.03 | 50.42 | 71.21 |
| MINIMUM H = 4.43 | | | | | | | | | | | | |
| | Y | 45 | | | | 2.17 | 5.00 | 7.83 | 12.07 | 16.31 | 24.80 | 41.77 |
| | L1 | 45 | | | | | 13.78 | 16.60 | 20.85 | 25.09 | 33.57 | 50.54 |
| | L2 | 45 | | | | | 20.47 | 23.30 | 27.55 | 31.79 | 40.27 | 57.24 |
| | Z | 45 | | | | | 21.35 | 23.35 | 26.35 | 29.35 | 35.35 | 47.35 |
| MINIMUM H = 8.02 | | | | | | | | | | | | |
| | Y | 60 | | | | | 1.26 | 3.56 | 7.03 | 10.49 | 17.42 | 31.28 |
| | L1 | 60 | | | | | | | 16.40 | 19.87 | 26.80 | 40.65 |
| | L2 | 60 | | | | | | | 25.34 | 28.80 | 35.73 | 49.58 |
| | Z | 60 | | | | | | | 22.79 | 24.52 | 27.99 | 34.91 |
| MINIMUM H = 12.24 | | | | | | | | | | | | |
| | Y | 90 | | | | | | | 1.25 | 4.25 | 10.25 | 22.25 |
| | L1 | 90 | | | | | | | | | 20.34 | 32.34 |
| | L2 | 90 | | | | | | | | | 33.74 | 45.74 |
| | Z | 90 | | | | | | | | | 21.34 | 21.34 |
| MINIMUM H = 21.34 | | | | | | | | | | | | |
| 2" IMC | | | | | | | | | | | | |
| | Y | 15 | | 5.04 | 12.77 | 20.50 | 28.22 | 35.95 | 47.54 | 59.13 | 82.31 | 128.68 |
| | L1 | 15 | 7.71 | 15.44 | 23.17 | 30.90 | 38.62 | 46.35 | 57.94 | 69.53 | 92.71 | 139.00 |
| | L2 | 15 | 10.19 | 17.92 | 25.64 | 33.37 | 41.10 | 48.83 | 60.42 | 72.01 | 95.19 | 141.56 |
| | Z | 15 | 14.56 | 22.03 | 29.49 | 36.96 | 44.42 | 51.89 | 63.00 | 74.28 | 96.67 | 141.45 |
| MINIMUM H = 1.84 | | | | | | | | | | | | |
| | Y | 22.5 | | 0.88 | 6.10 | 11.33 | 16.56 | 21.78 | 29.62 | 37.46 | 53.14 | 84.50 |
| | L1 | 22.5 | | 10.40 | 15.63 | 20.86 | 26.08 | 31.31 | 39.15 | 46.99 | 62.67 | 94.02 |
| | L2 | 22.5 | | 14.12 | 19.35 | 24.57 | 29.80 | 35.02 | 42.86 | 50.70 | 66.38 | 97.74 |
| | Z | 22.5 | | 18.03 | 22.86 | 27.69 | 32.52 | 37.34 | 44.59 | 51.83 | 66.31 | 95.29 |
| MINIMUM H = 3.20 | | | | | | | | | | | | |
| | Y | 30 | | | 2.50 | 6.50 | 10.50 | 14.50 | 20.50 | 26.50 | 38.50 | 62.50 |
| | L1 | 30 | | | 11.88 | 15.88 | 19.88 | 23.88 | 29.88 | 35.88 | 47.88 | 71.88 |
| | L2 | 30 | | | 16.84 | 20.84 | 24.84 | 28.84 | 34.84 | 40.84 | 52.84 | 76.84 |
| | Z | 30 | | | 20.07 | 23.54 | 27.00 | 30.46 | 35.66 | 40.86 | 51.25 | 72.03 |
| MINIMUM H = 4.84 | | | | | | | | | | | | |
| | Y | 45 | | | | 1.12 | 3.94 | 6.77 | 11.02 | 15.26 | 23.74 | 40.71 |
| | L1 | 45 | | | | | 13.74 | 16.56 | 20.81 | 25.05 | 33.53 | 50.50 |
| | L2 | 45 | | | | | 21.16 | 23.99 | 28.24 | 32.48 | 40.96 | 57.93 |
| | Z | 45 | | | | | 22.45 | 24.45 | 27.45 | 30.45 | 36.45 | 48.45 |
| MINIMUM H = 8.80 | | | | | | | | | | | | |
| | Y | 60 | | | | | 0.11 | 2.42 | 5.89 | 9.35 | 16.28 | 20.13 |
| | L1 | 60 | | | | | | | 16.30 | 19.77 | 26.70 | 20.55 |
| | L2 | 60 | | | | | | | 26.21 | 29.67 | 36.60 | 50.46 |
| | Z | 60 | | | | | | | 24.19 | 25.93 | 29.39 | 26.32 |
| MINIMUM H = 13.45 | | | | | | | | | | | | |
| | Y | 90 | | | | | | | | 2.75 | 8.75 | 20.75 |
| | L1 | 90 | | | | | | | | | 19.94 | 31.94 |
| | L2 | 90 | | | | | | | | | 34.80 | 46.80 |
| | Z | 90 | | | | | | | | | 23.53 | 23.53 |
| MINIMUM H = 23.53 | | | | | | | | | | | | |

Handle Removal and Replacement

The handle of the 555C is designed to be removable. This feature is convenient when performing complex bending, and makes it easy to replace a damaged handle.

Removal

1. Place the bender in the upright position.
2. Release the spring clip on the safety snap pin (79).
3. Remove the pin from the handle (80) and the sleeve of the frame (1).
4. Repeat Steps 1 through 3 for the other end of the handle.
5. Lift the handle to remove.

Replacement

1. Insert the handle (80) into the sleeves of the frame (1).
2. Align the holes in the handle with the holes in the sleeves.
3. Insert the safety snap pin (79). Ensure that the pin goes through the handle and the sleeve on the frame (1).
4. Engage the safety spring clip over the end of the pin. Ensure that the loop on the clip is completely around the pin.
5. Repeat Steps 2 through 4 for the other end of the handle.

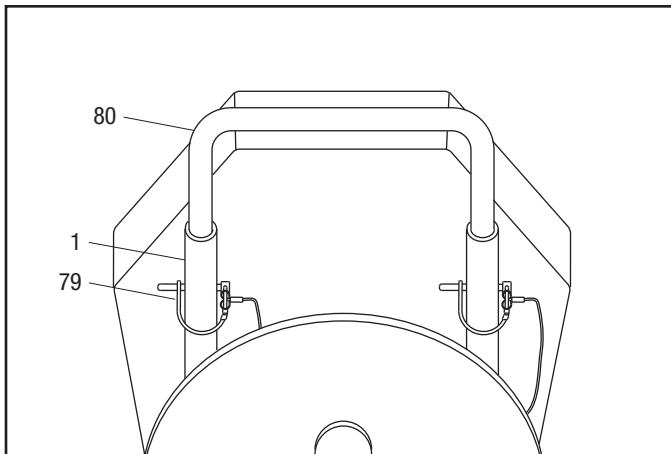

Removing or Replacing Handle

Transportation

⚠ WARNING

Make sure that the handle is properly installed and secured with the safety spring clips and snap pins before lifting or moving the bender. An improperly installed handle could allow the bender to fall, injuring nearby personnel.

Failure to observe this warning could result in severe injury or death.

The only proper way to lift this bender is by attaching a nylon or polyester sling around the storage spindle. The sling should extend between the handle and main frame of the bender so that the handle acts as a guide for the sling, as shown.

Make sure that all components used to lift this bender are properly rated for the 159 kg (350 lb) weight. Use a ramp to load and unload from a truck or other vehicle that is not equipped with a lift gate.

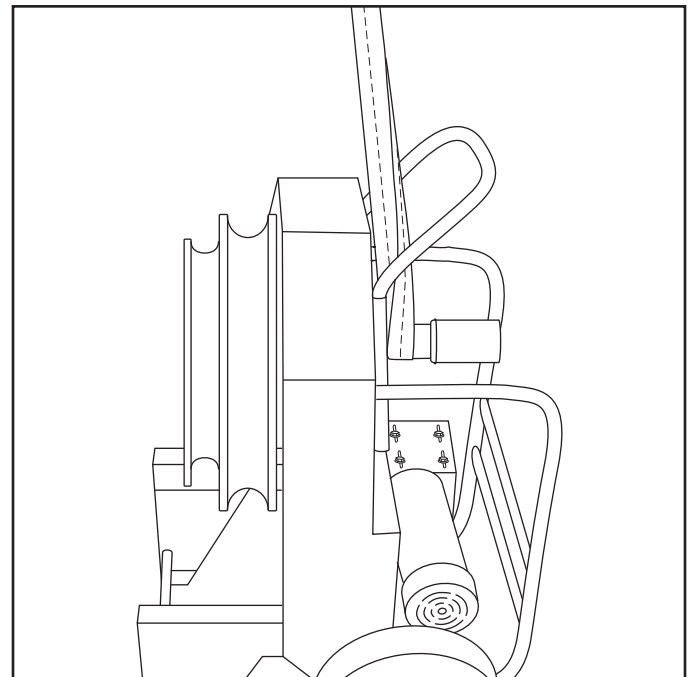

Transporting Bender

Maintenance

There is no need for periodic flushing and replacing of lube in the bender gear box since it is sealed and locked tight. However, if the box is opened for repair and the lube is lost or contaminated by dirt, then the box and parts should be flushed out and filled with 26 fluid ounces of Mobil® 634 synthetic oil.

Flushing should be accomplished with kerosene, which is a petroleum hydrocarbon that does not affect seals.

Note: Aromatic hydrocarbons such as benzene, chlorinated solvents such as carbon-tetrachloride, and ketones such as acetone should never be used for flushing as they are solvents for rubber. They are also harmful to the environment.

| | |
|---|---|
|  | ⚠ WARNING |
| | <p>Disconnect this tool when not in use, before servicing or adjusting, and when changing shoes or conduit rollers and supports.</p> <p>Failure to observe this warning could result in severe injury or death.</p> |

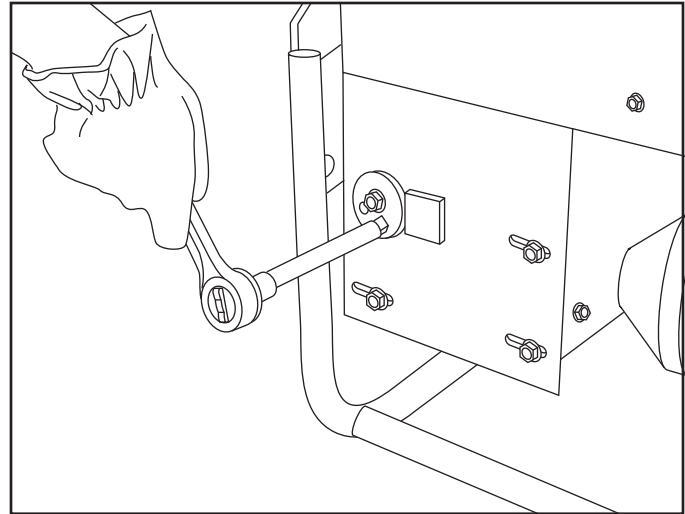

With the eight reductor mounting bolts (22, 24) loose, rotate the eccentric cam with a 1/2" square drive to tension the chain. Torque the eight reductor mounting bolts to 47 Newton-meters (35 ft-lb).

Chain Adjustment

Both chains have to be adjusted if the final drive #60 chain is to be reset. Refer to the Exploded View and Parts List.

1. Remove the front cover (38) and upper rear guard (37).
2. Loosen the eight mounting bolts for the reductor (19). Remove the eccentric cam and move the reductor to create chain slack.
3. Remove the four retaining screws for eccentric adjustment. Rotate to remove slack from the chain and align with one of the two sets of holes in the frame. Remount the eccentric with the four bolts.
4. Slide the reductor in slotted mounting holes to the retension chain. Set tension with the eccentric cam.

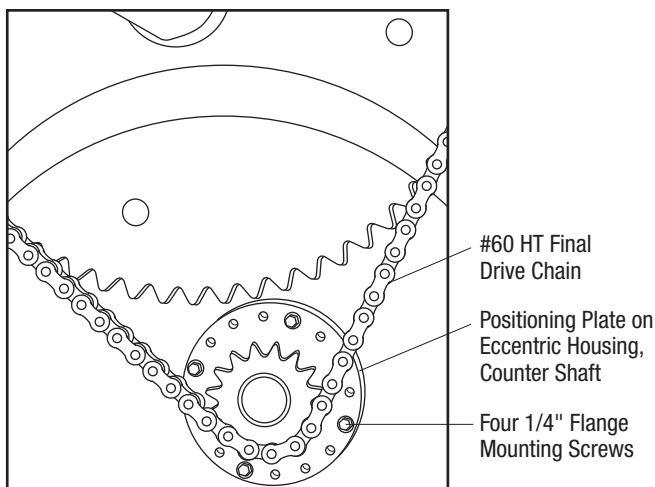
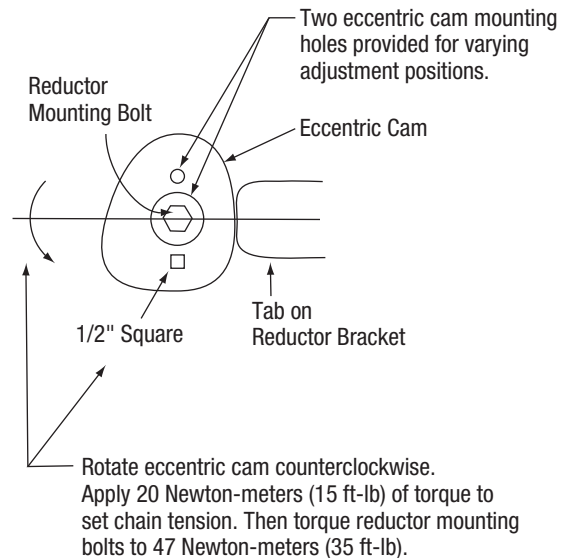

Troubleshooting

| Problem | Probable Cause | Possible Remedy |
|------------------------------------|--|---|
| Bender will not operate. | No voltage. | Check supply voltage circuit operation. |
| | | Check that switch is on. |
| Bends are overbent a few degrees. | Too much squeeze on 1-1/2" or 2" EMT or IMC conduit. | Back squeeze off per adjustment instructions. |
| | Unusual conduit characteristics. | Bend smaller angle to compensate. |
| Bends are underbent a few degrees. | Too little squeeze on 1-1/2" or 2" EMT or IMC conduit. | Increase squeeze per adjustment instructions. |
| | Unusual conduit characteristics. | Bend larger angle to compensate. |

Troubleshooting (cont'd)

The following flow charts show the suggested troubleshooting procedures for some bender problems. They by no means encompass all possible problems or solutions.

| | |
|---|--|
|  | <p>⚠ WARNING</p> |
| | <p>Electric shock hazard:</p> <ul style="list-style-type: none"> • Contact with live circuits can result in severe injury or death. • Some troubleshooting steps require power to the bender. This type of troubleshooting step should only be performed at authorized Greenlee service centers by personnel who are familiar with safe troubleshooting procedures. <p>Failure to observe these warnings could result in severe injury or death.</p> |

Trips 555C switch/circuit breaker

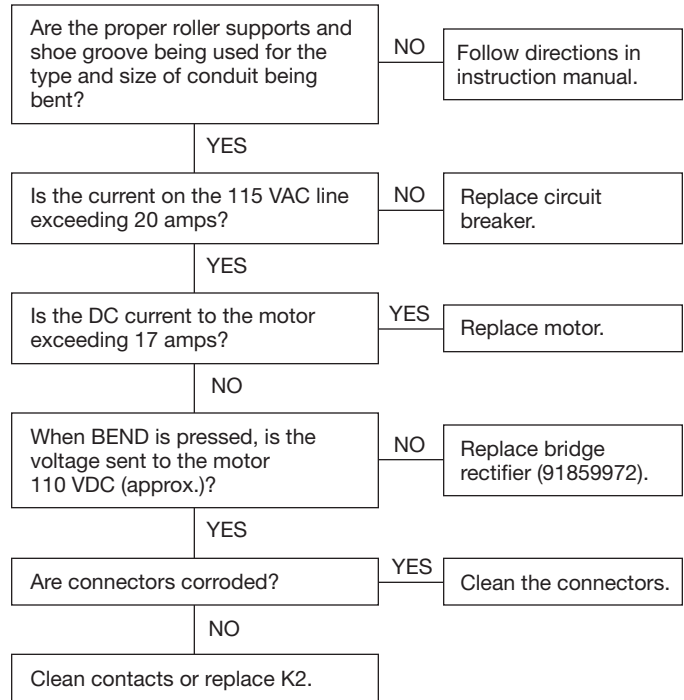

Won't stop

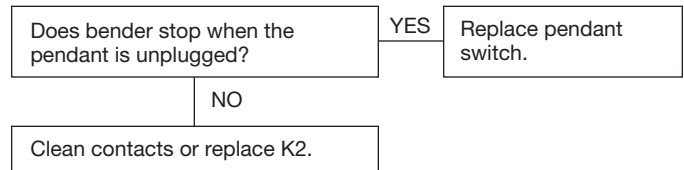

Troubleshooting (cont'd)

Won't bend

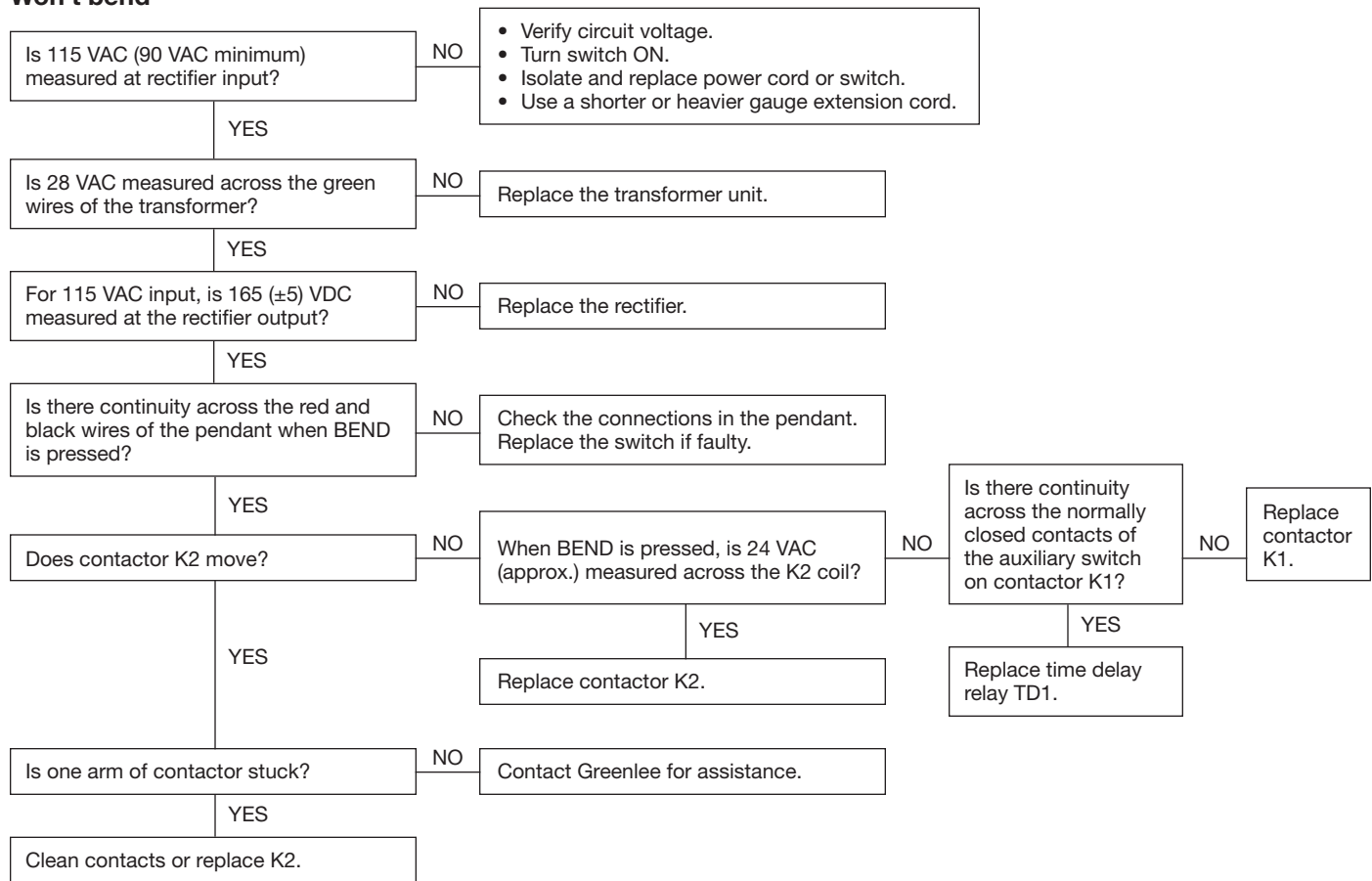

Bender runs only in the BEND direction

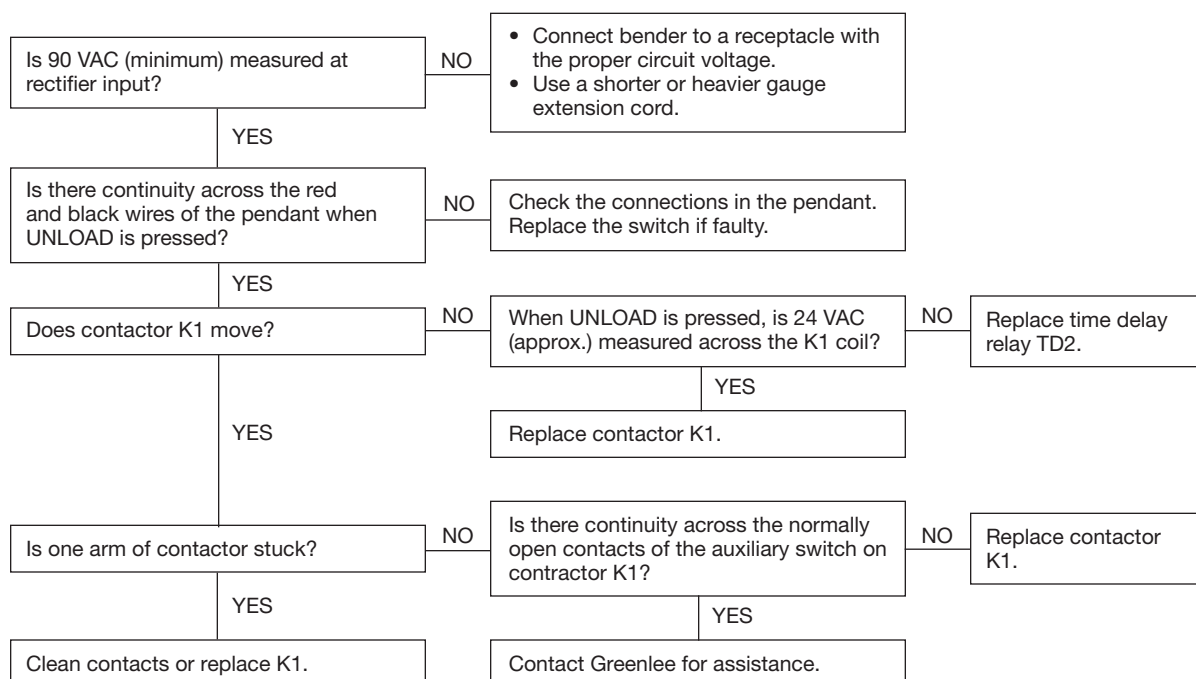
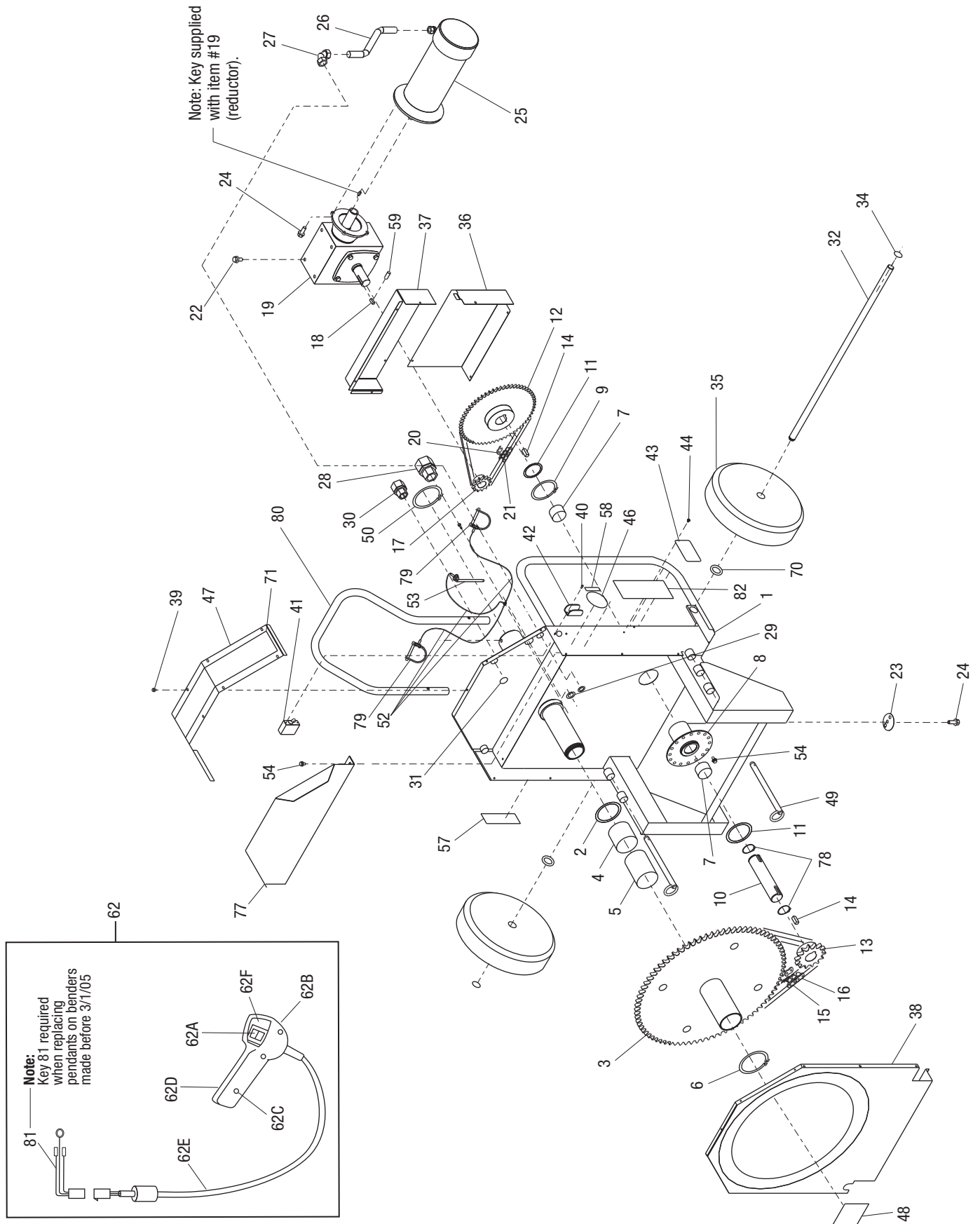
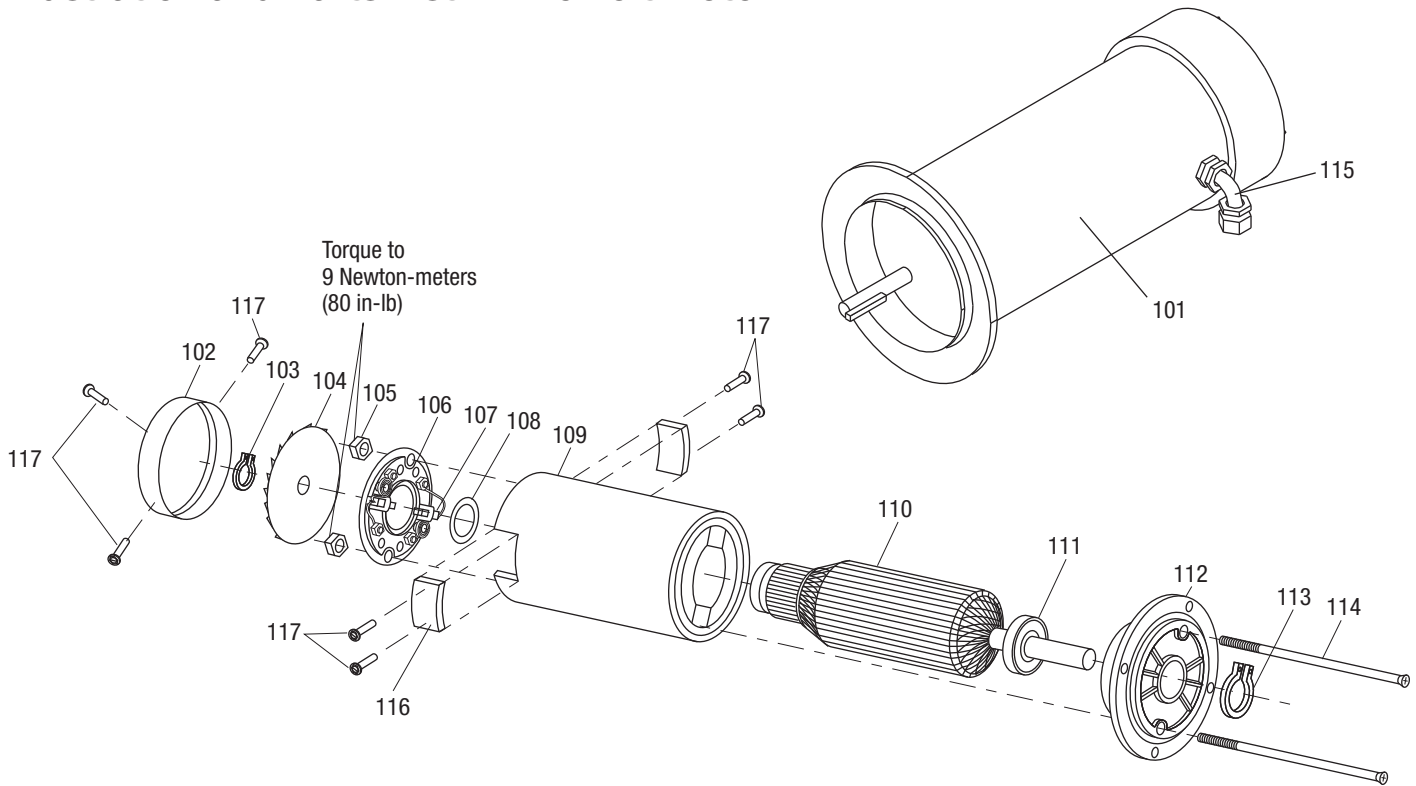

Illustration – 555C Electric Bender Classic



Parts List — 555C Electric Bender Classic

| Key | Part No. | Description | Qty | Key | Part No. | Description | Qty |
|-----|----------|--|-----|-----|----------|---|-----|
| 1 | 50397427 | Weldment, main frame | 1 | 40 | 90504305 | Screw, #6–32 x .375 Phillips | 2 |
| 2 | 50234528 | Washer, fiber..... | 1 | 41 | 91863856 | Switch, air pax..... | 1 |
| 3 | 50328964 | Weldment, sprocket unit | 1 | 42 | 50297082 | Guard, switch | 1 |
| 4 | 90524098 | Bearing, Fiberglide® ø2.625 x 2.5 long.... | 1 | 43 | 50069055 | Nameplate | 1 |
| 5 | 90524101 | Bearing, Fiberglide ø2.625 x 3.75 long ... | 1 | 44 | 90530012 | Rivet, pop 1/8 x 1/8 drive..... | 4 |
| 6 | 90524144 | Ring, retaining #5100-237 | 1 | 46 | 50303929 | Decal, damp warning | 1 |
| 7 | 90524128 | Bearing, Fiberglide ø1.625 x 1.00 long ... | 2 | 47 | 50397591 | Cover, top..... | 1 |
| 8 | 50397630 | Weldment, countershaft..... | 1 | 49 | 90533895 | Pin, hitch | 2 |
| 9 | 90540239 | Ring, retaining #5100-250 | 1 | 50 | 90525019 | Ring, retaining #5100-287 | 1 |
| 10 | 50397648 | Countershaft | 1 | 52 | 90545524 | Lanyard | 3 |
| 11 | 90524136 | Bearing, thrust Fiberglide | 2 | 53 | 90545451 | Pin, hitch | 1 |
| 12 | 90545486 | Sprocket, #40 60T..... | 1 | 54 | 90543351 | Screw, 1/4 x .37 thread-forming..... | 6 |
| 13 | 90542533 | Sprocket, #60 14T..... | 1 | 57 | 50339370 | Decal, squeeze adjust | 1 |
| 14 | 50397656 | Key, countershaft | 2 | 58 | 50389742 | Decal, circuit breaker | 1 |
| 15 | 90545460 | Chain, #60 87P..... | 1 | 59 | 90553233 | Pin, DRIV-LOK®, 1/8 x 1/2..... | 1 |
| 16 | 90542517 | Masterlink, #60..... | 1 | 61 | 50079123 | Power cord, Twist-Lock 20 Amp..... | 1 |
| 17 | 90545478 | Sprocket, #40 13T..... | 1 | 62 | 50398393 | Switch, pendant (complete assembly with Molex plug)..... | 1 |
| 18 | 50084313 | Key, reductor sprocket | 1 | 62A | 91864496 | Switch, center OFF..... | 1 |
| 19 | 90523881 | Reductor, worm gear..... | 1 | 62B | 50319027 | Handle, right half | 1 |
| 20 | 90527879 | Masterlink, #40..... | 1 | 62C | 90534417 | Screw, #6–20 x .625 pan head, self-tapping..... | 3 |
| 21 | 90545516 | Chain, #40 87P..... | 1 | 62D | 50319019 | Handle, left half..... | 1 |
| 22 | 90545680 | Bolt, 3/8–16 UNC x .75 | 7 | 62E | 50398377 | Cord..... | 1 |
| 23 | 50397583 | Eccentric | 1 | 62F | 50354876 | Decal, faceplate | 1 |
| 24 | 90542371 | Bolt, 3/8–16 UNC x 1.00 | 5 | 70 | 90517407 | Washer, flat..... | 2 |
| 25 | 91869730 | Motor..... | 1 | 71 | 52066299 | Decal, instruction | 1 |
| 26 | 90545494 | Conduit, Sealtight..... | 1 | 77 | 50068890 | Electronic control assembly | 1 |
| 27 | 91852145 | Elbow, Sealtight..... | 1 | 78 | 90510518 | Ring, retaining #5100-150 | 2 |
| 28 | 91866839 | Strain relief | 1 | 79 | 90552687 | Pin, safety snap..... | 2 |
| 29 | 90511700 | Nut, 3/4 conduit lock..... | 1 | 80 | 50397486 | Handle, upper..... | 1 |
| 30 | 91867673 | Strain relief, pendant switch..... | 1 | 81 | 50120620 | Adapter, with Molex plug (required when replacing pendant switch on units made prior to 3/1/05) | 1 |
| 31 | 91862639 | Nut, 1/2 conduit lock..... | 1 | 82 | 52025721 | Decal, safety/warning..... | 1 |
| 32 | 50397575 | Axle | 1 | | | | |
| 34 | 90515285 | Ring, retaining #5160-75..... | 2 | | | | |
| 35 | 90533909 | Wheel | 2 | | | | |
| 36 | 50397680 | Guard, rear lower..... | 1 | | | | |
| 37 | 50397699 | Guard, rear upper..... | 1 | | | | |
| 38 | 50397605 | Cover, front..... | 1 | | | | |
| 39 | 90516559 | Screw, #10–16 x .50 hex head | 31 | | | | |

Illustration and Parts List — 115 Volt Motor

Pacific Scientific

| Key | Part No. | Description | Qty |
|-----|----------|---|-----|
| 101 | 91869730 | Motor (SRF-3648-5532-7-56C)..... | 1 |
| * | 91864178 | Motor, 115 Volt (standard) (SRF-3745-4676-2-56C)..... | 1 |
| 102 | 91864712 | Fan cover | 1 |
| 103 | 90550714 | Retaining ring | 1 |
| 104 | 91864321 | Fan | 1 |
| 105 | 91864283 | End bell nut | 2 |
| 106 | 91864194 | Bell, rear end | 1 |
| 107 | 91864208 | Brush..... | 2 |
| 108 | 91864224 | Thrust washer | 1 |
| 109 | 91869757 | Shell and magnet assembly..... | 1 |
| * | 91864275 | Shell and magnet assembly, 115V..... | 1 |
| 110 | 91869749 | Armature | 1 |
| * | 91864259 | Armature, 115V | 1 |
| 111 | 91864216 | Bearing kit | 2 |
| 112 | 91864186 | Bell, front end..... | 1 |
| 113 | 91864240 | Retaining ring | 1 |
| 114 | 91864267 | Tie bolt, 115V | 2 |
| 115 | 91858763 | 90° Connector..... | 1 |
| 116 | 91864305 | Brush cover..... | 2 |
| 117 | 91864313 | Cover screw | 7 |

*Note: Alternate motor
Check motor part number before ordering magnet shell or armature.

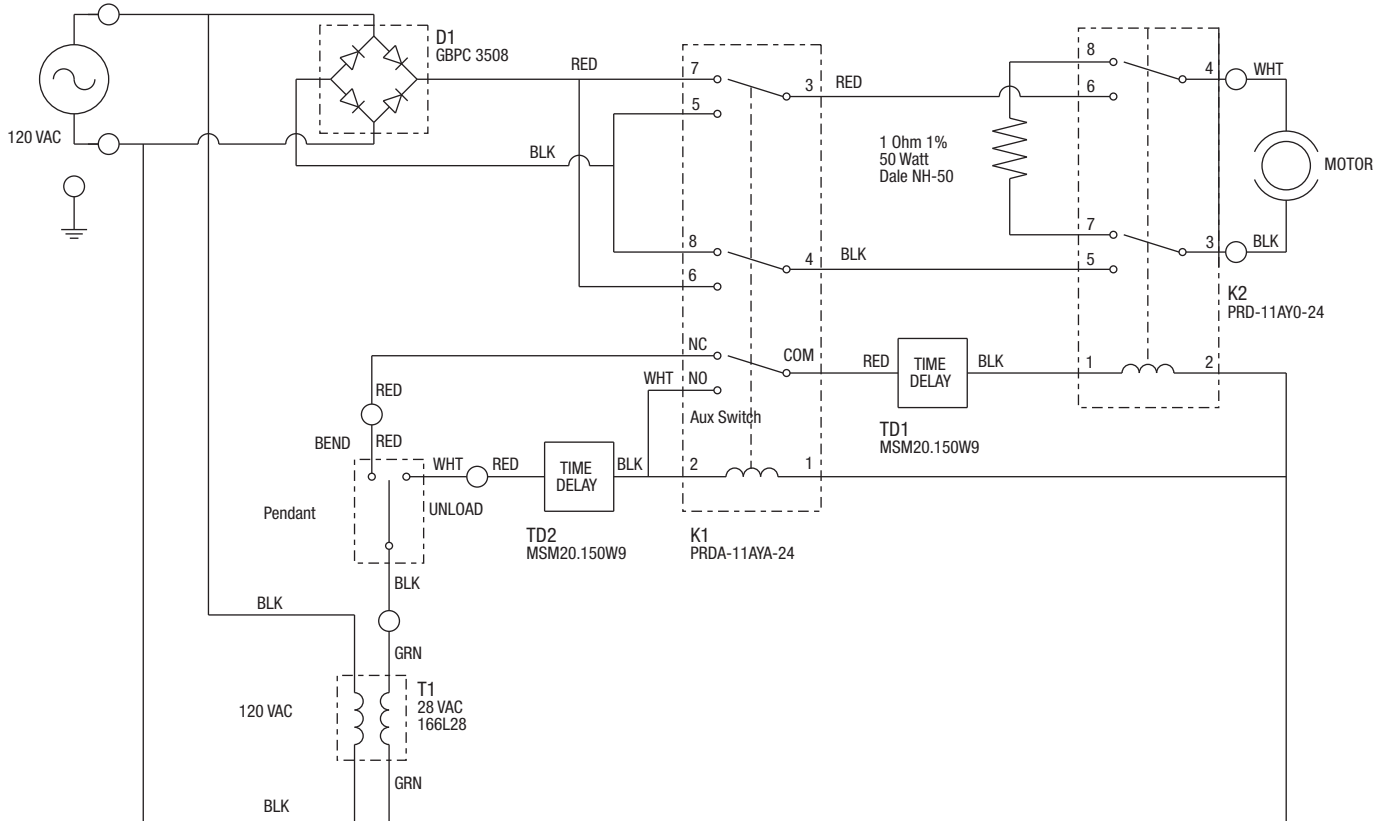
Schematic Diagram

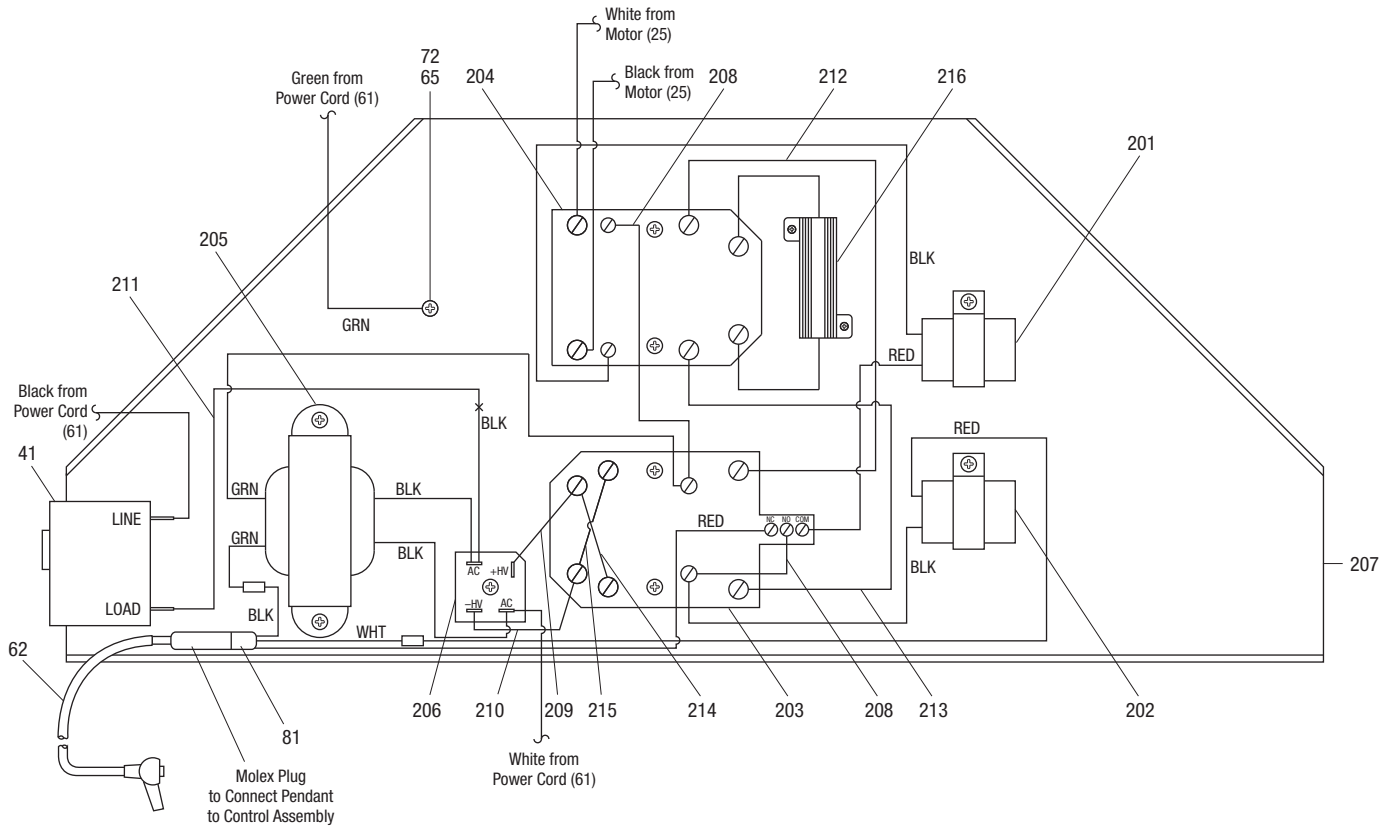

Control Assembly

Electronic Control Assembly – Part No. 50068890

| Key | Schematic Reference | Part No. | Description | Qty |
|-----|---------------------|----------|--|-----|
| 201 | TD1 | 50069152 | Timer assembly, 150 ms ON Delay | 1 |
| 202 | TD2 | 50069071 | Timer assembly, 150 ms ON Delay | 1 |
| 203 | K1 | 91869668 | Relay, power, DPDT (with switch) | 1 |
| 204 | K2 | 91869676 | Relay, power, DPDT | 1 |
| 205 | T1 | 50069080 | Transformer assembly..... | 1 |
| 206 | D1 | 91859972 | Bridge rectifier..... | 1 |
| 207 | | 50068954 | Bracket, electrical mounting | 1 |
| 208 | | 50068962 | Wire harness, 14 AWG | 2 |
| 209 | | 50060341 | Wire harness, 12 AWG (RED) | 1 |
| 210 | | 50060350 | Wire harness, 12 AWG (BLK) | 1 |
| 211 | | 50069160 | Wire unit, BLK Rectifier..... | 1 |
| 212 | | 50068989 | Wire harness, 12 AWG (RED)..... | 1 |
| 213 | | 50068997 | Wire harness, 12 AWG (BLK) | 1 |
| 214 | | 50060481 | Wire harness, 12 AWG (RED)..... | 1 |
| 215 | | 50060490 | Wire harness, 12 AWG (BLK) | 1 |
| 216 | | 50060511 | Resistor unit with leads..... | 1 |
| 65 | | 90543297 | Screw, #8–32 x .37 ground | 1 |
| 72 | | 90537246 | Washer, internal tooth lock..... | 1 |
| 81 | | 50120620 | Adapter with Molex Plug..... | 1 |

Bending Shoes and Roller Supports

28008 BENDING SHOE AND ROLLER SUPPORT

1/2" to 2" Rigid Conduit

1/2" to 1-1/4" IMC Conduit

| Key | Part No. | Description | Qty |
|-----|----------|--|-----|
| | 52066935 | Shoe unit, 1/2"-2" rigid/IMC | 1 |
| | 52066936 | Roller support unit, 1/2"-2" rigid..... | 1 |
| 1 | 52066937 | Roller support, 1/2"-1-1/4" | 1 |
| 2 | 52065278 | Pointer kit (includes one each 2A-2C) | |
| 2A | | Point..... | 2 |
| 2B | | Washer, 1/4" standard..... | 2 |
| 2C | | Screw, 1/4-20 x 3/8 hex hd cap..... | 2 |
| 3 | 52065279 | Hook kit, 1/2"-1-1/4" rigid/IMC | |
| 3A | | Hook, 1/2"-1-1/4" rigid/IMC | 1 |
| 3B | | Screw, 3/8-16 x 1-1/4 skt hd cap..... | 4 |
| 4 | 52065280 | Hook kit, 1-1/2"-2" rigid/IMC | |
| 4A | | Hook, 1-1/2"-2" rigid/IMC | 1 |
| 4B | | Shoulder screw, ϕ .75 x 1.50 x 5/8-11 | 3 |
| 5 | 52066933 | Drive pin | 4 |

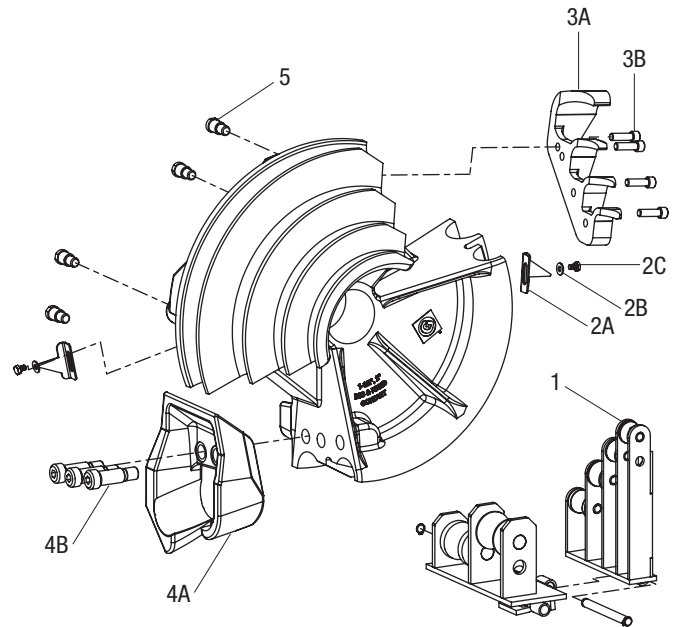

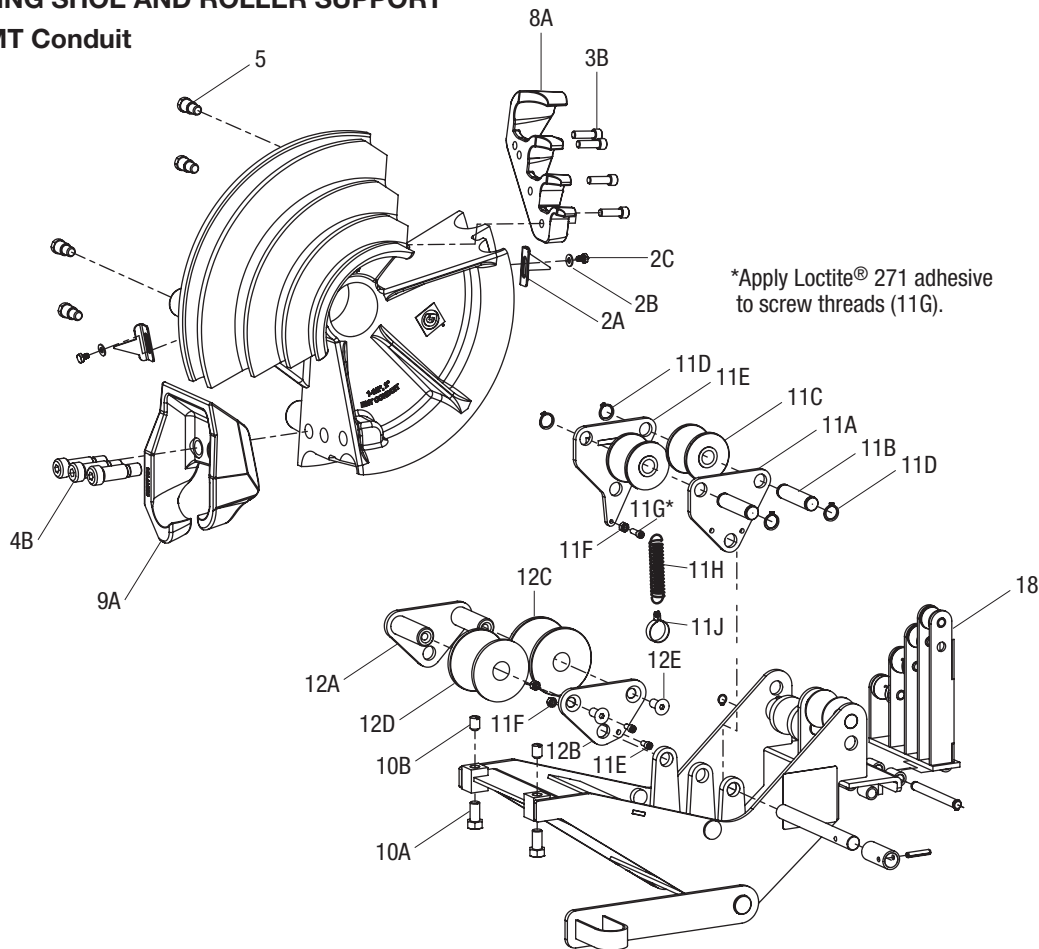
Bending Shoes and Roller Supports (cont'd)
23803 BENDING SHOE AND ROLLER SUPPORT
1/2" to 2" EMT Conduit

| Key | Part No. | Description | Qty |
|-----|----------|--|-----|
| | 52066931 | Shoe unit, 1/2"-2" EMT..... | 1 |
| | 52066932 | Bridge unit, 1/2"-2" EMT | 1 |
| 2 | 52065278 | Pointer kit (includes one each 2A-2C) | |
| 2A | | Point..... | 2 |
| 2B | | Washer, 1/4" standard..... | 2 |
| 2C | | Screw, 1/4-20 x 3/8 hex hd cap..... | 2 |
| 8 | 52065321 | Hook kit, 1/2"-1-1/4" EMT | |
| 8A | | Hook, 1/2"-1-1/4" EMT..... | 1 |
| 3B | | Screw, 3/8-16 x 1-1/4 skt hd cap..... | 4 |
| 9 | 52065322 | Hook kit, 1-1/2"-2" EMT | |
| 9A | | Hook, 1-1/2"-2" EMT..... | 1 |
| 4B | | Shoulder screw, ø.75 x 1.50 x 5/8-11 | 3 |
| 5 | 52066933 | Drive pin | 4 |
| 10 | 52065273 | Screw kit (includes one each 10A-10B) | |
| 10A | | Screw, 1/2-13 x 1 hex hd cap | 2 |
| 10B | | Screw, 1/2-13 x 3/4 slotted set..... | 2 |

| Key | Part No. | Description | Qty |
|-----|----------|---|-----|
| 11 | 52065274 | Roller kit, 1-1/2" EMT | |
| 11A | | Pivot plate | 1 |
| 11B | | Pin, 1-1/2" EMT roller..... | 2 |
| 11C | | Roller, 1-1/2" EMT | 2 |
| 11D | | Retaining ring, Truarc #5160 EX..... | 4 |
| 11E | | Pivot plate, rear | 1 |
| 11F | | Hex nut, 1/4-20 | 1 |
| 11G | | Screw, 1/4-20 x 3/4 skt hd cap..... | 1 |
| 11H | | Spring, extension | 1 |
| 11J | | Clamp, loop type..... | 1 |
| 12 | 52065275 | Roller kit, 2" EMT | |
| 12A | | Support weldment, 2" EMT..... | 1 |
| 12B | | Plate, 2" EMT | 1 |
| 12C | | Roller, 2" EMT back (larger OD) | 1 |
| 12D | | Roller, 2" EMT front (smaller OD) | 1 |
| 12E | | Screw, 7/16-14 x 1 flat hd cap | 2 |
| 11E | | Screw, 1/4-20 x 1/2 skt hd cap..... | 2 |
| 11F | | Hex nut, 1/4-20 | 2 |
| 18 | 52066934 | Roller support, 1/2"-1-1/4" EMT..... | 1 |

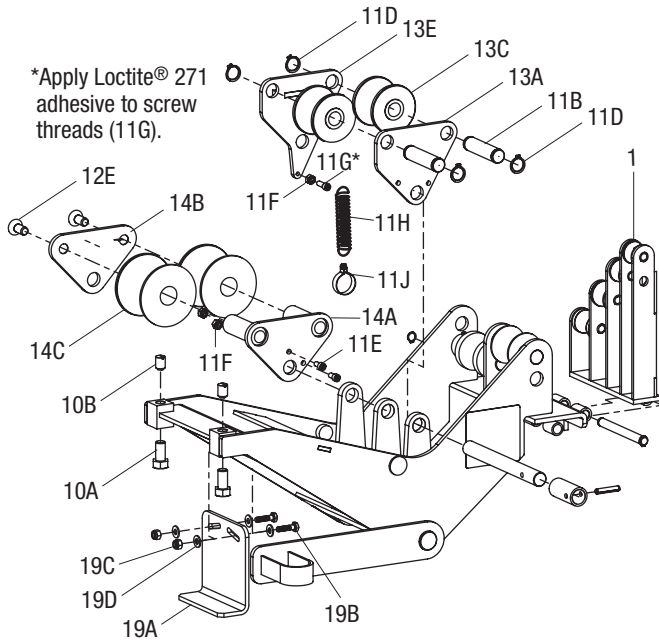
Bending Shoes and Roller Supports (cont'd)
01323 BRIDGE UNIT
1/2" to 2" IMC and Rigid Conduit

*Apply Loctite® 271 adhesive to screw threads (11G).

| Key | Part No. | Description | Qty |
|-----|----------|--|-----|
| | 52064757 | Bridge unit, 1/2"-2" IMC/rigid..... | 1 |
| 10 | 52065273 | Screw kit (includes one each 10A-10B) | |
| 10A | | Screw, 1/2-13 x 1 hex hd cap..... | 2 |
| 10B | | Screw, 1/2-13 x 3/4 slotted set..... | 2 |
| 13 | 52065276 | Roller kit, 1-1/2" IMC | |
| 13A | | Pivot plate..... | 1 |
| 11B | | Pin, 1-1/2" EMT roller..... | 2 |
| 13C | | Roller, 1-1/2" IMC..... | 2 |
| 11D | | Retaining ring, Truarc #5160 EX..... | 4 |
| 13E | | Pivot plate, rear..... | 1 |
| 11F | | Hex nut, 1/4-20..... | 1 |
| 11G | | Screw, 1/4-20 x 3/4 skt hd cap..... | 1 |
| 11H | | Spring, extension..... | 1 |
| 11J | | Clamp, loop type..... | 1 |
| 14 | 52065277 | Roller kit, 2" IMC | |
| 14A | | Support weldment, 2" IMC..... | 1 |
| 14B | | Plate, 2" IMC..... | 1 |
| 14C | | Roller, 2" IMC..... | 2 |
| 12E | | Screw, 7/16-14 x 1 flat hd cap..... | 2 |
| 11E | | Screw, 1/4-20 x 1/2 skt hd cap..... | 2 |
| 11F | | Hex nut, 1/4-20..... | 2 |
| 1 | 52066937 | Roller support, 1/2"-1-1/4" IMC/rigid..... | 1 |
| 19 | 52066949 | Plate kit (includes 19A-19D) | |
| 19A | | Plate, bridge trap..... | 1 |
| 19B | | Screw, 1/4-20 x 1-1/4 hex hd cap..... | 2 |
| 19C | | Lock nut, 1/4-20..... | 2 |
| 19D | | Washer, 1/4" standard..... | 4 |

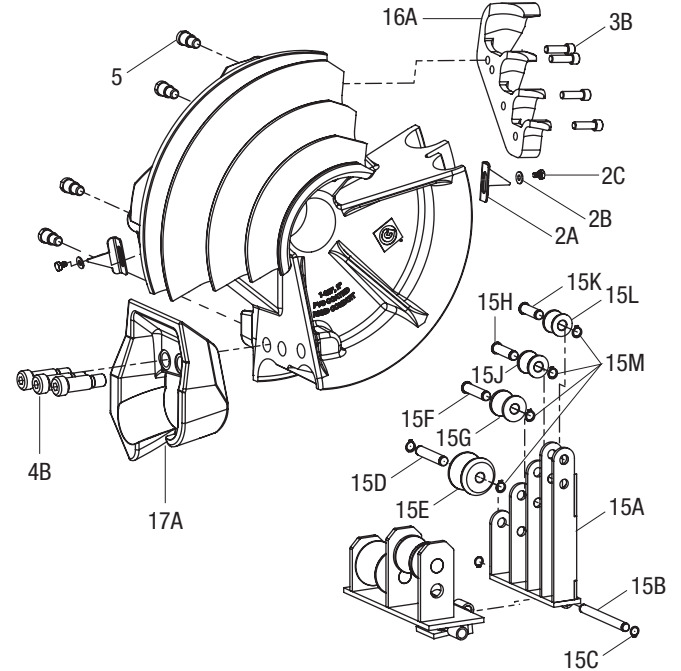
12586 PVC BENDING SHOE AND ROLLER SUPPORT
1/2" to 2" 40 MIL PVC-Coated Rigid Conduit

| Key | Part No. | Description | Qty |
|-----|----------|---|-----|
| | 52066939 | Shoe unit, 1/2"-2" PVC-coated rigid | |
| | 52066940 | Roller support unit, 1/2"-2" | |
| 15 | 52065272 | Roller support, 1/2"-1-1/4" | |
| 15A | | Support weldment..... | 1 |
| 15B | | Pivot pin..... | 1 |
| 15C | | Retaining ring, Truarc #5160-42 EX..... | 2 |
| 15D | | Axle, 1-1/4" roller..... | 1 |
| 15E | | Roller, 1-1/4"..... | 1 |
| 15F | | Axle, 1" roller..... | 1 |
| 15G | | Roller, 1"..... | 1 |
| 15H | | Axle, 3/4" roller..... | 1 |
| 15J | | Roller, 3/4"..... | 1 |
| 15K | | Axle, 1/2" roller..... | 1 |
| 15L | | Roller, 1/2"..... | 1 |
| 15M | | Retaining ring, Truarc #5160-50 EX..... | 5 |
| 2 | 52065278 | Pointer kit (includes one each 2A-2C) | |
| 2A | | Point..... | 2 |
| 2B | | Washer, 1/4" standard..... | 2 |
| 2C | | Screw, 1/4-20 x 3/8 hex hd cap..... | 2 |
| 16 | 52065323 | Hook kit, 1/2"-1-1/4" PVC | |
| 16A | | Hook, 1/2"-1-1/4" PVC..... | 1 |
| 3B | | Screw, 3/8-16 x 1-1/4 skt hd cap..... | 4 |
| 17 | 52065324 | Hook kit, 1-1/2"-2" PVC | |
| 17A | | Hook, 1-1/2"-2" PVC..... | 1 |
| 4B | | Shoulder screw, ø.75 x 1.50 x 5/8-11..... | 3 |
| 5 | 52066933 | Drive pin..... | 4 |

Bending Shoes and Roller Supports (cont'd)

BENDING SHOE AND ROLLER SUPPORT 1/2" to 1-1/4" IMC and Rigid Conduit

| Key | Part No. | Description | Qty |
|-----|----------|---|-----|
| 1 | 50009362 | Roller support, 1/2" to 1-1/4" IMC and rigid..... | 1 |
| | 50005715 | Bending shoe assembly (includes 2-4) | 1 |
| 2 | 50005693 | Hook..... | 1 |
| 3 | | Screw, 3/8-16 UNC x 1-1/4" socket head cap..... | 4 |
| 4 | 50234226 | Stud, drive | 3 |

Shoe not available separately.

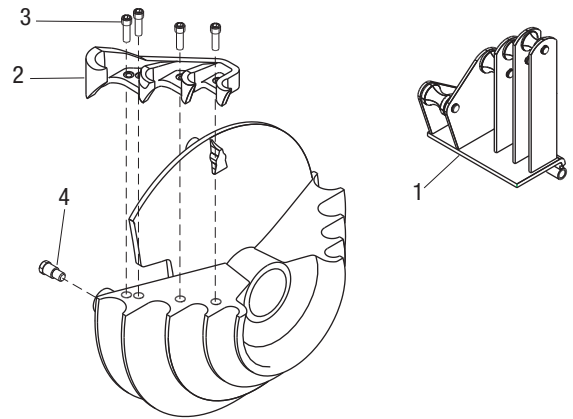

BENDING SHOE AND ROLLER SUPPORT 1-1/2" to 2" Rigid Conduit

| Key | Part No. | Description | Qty |
|-----|----------|---|-----|
| 1 | 50179845 | Roller support, 1-1/2" to 2" rigid conduit | 1 |
| | 50179373 | Bending shoe assembly, 1-1/2" to 2" rigid conduit (includes 2-8)..... | 1 |
| 2 | 50179691 | Pipe hook | 1 |
| 3 | 50179748 | Pivot | 1 |
| 4 | 90526759 | Washer, 5/8 flat..... | 1 |
| 5 | 90515692 | Nut, 5/8-11 UNC hex | 1 |
| 6 | 90509056 | Lock washer, 5/8 split | 1 |
| 7 | 90524268 | Screw, 5/8-11 UNC x 4" socket head cap..... | 1 |
| 8 | 50234226 | Stud, drive..... | 4 |

Shoe not available separately.

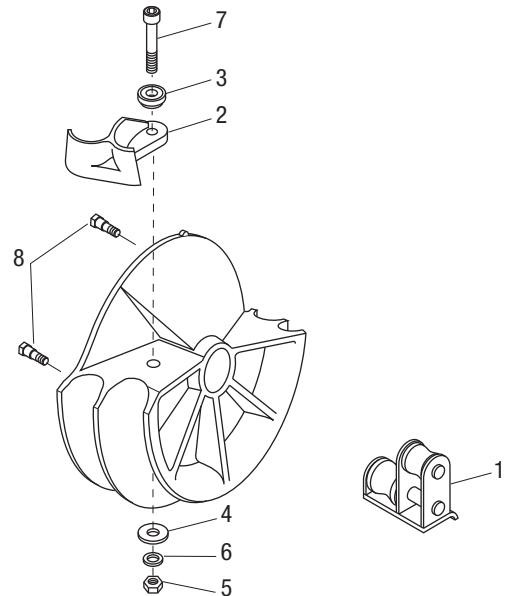

BENDING SHOE AND PIPE REST 1/2" to 1-1/4" EMT Conduit

| Key | Part No. | Description | Qty |
|-----|----------|--|-----|
| 1 | 50179861 | Pipe rest assembly for 1/2" to 1-1/4" EMT conduit..... | 1 |
| | 50179446 | Bending shoe assembly for 1/2" to 2-1/4" EMT conduit (includes 2-8)..... | 1 |
| 2 | | Screw, 3/8-16 UNC x 1" socket head cap..... | 1 |
| 3 | | Lock washer, 3/8 split | 3 |
| 4 | 50245554 | Pipe hook | 1 |
| 5 | 50234226 | Stud, drive..... | 4 |
| 6 | | Nut, 3/8-16 UNC hex, cad.-plated..... | 2 |
| 7 | | Screw, 3/8-16 UNC x 1-1/4 SAE grade 5 socket head cap..... | 1 |
| 8 | | Screw, 3/8-16 UNC x 1-1/4 socket head | 1 |

Shoe not available separately.

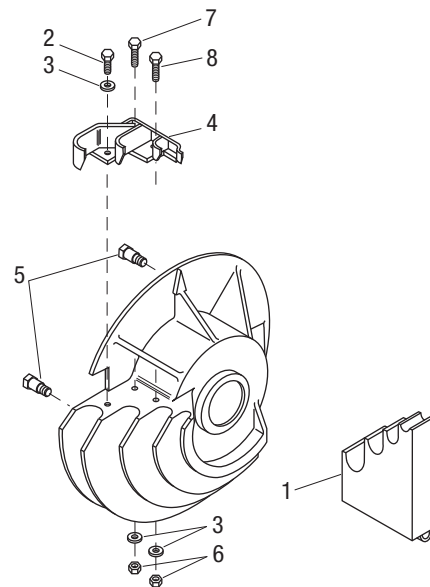

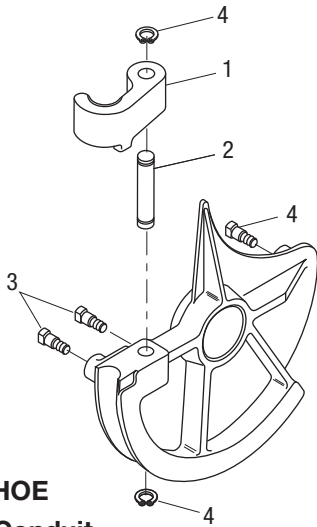
Bending Shoes and Roller Supports (cont'd)

**BENDING SHOE
1-1/2" EMT Conduit**

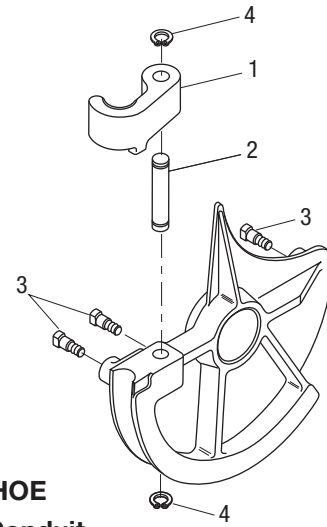
| Key | Part No. | Description | Qty |
|-----|----------|---|-----|
| | 50234994 | Shoe unit, 1-1/2" EMT (includes 1-4)..... | 1 |
| 1 | 50188208 | Hook, 1-1/2" EMT | 1 |
| 2 | 50188410 | Pin, 1-1/2" EMT hook..... | 1 |
| 3 | 50234226 | Stud, drive..... | 3 |
| 4 | 90515293 | Ring, Tru-Arc #5160-87 retaining | 2 |

**BENDING SHOE
1-1/2" IMC Conduit**

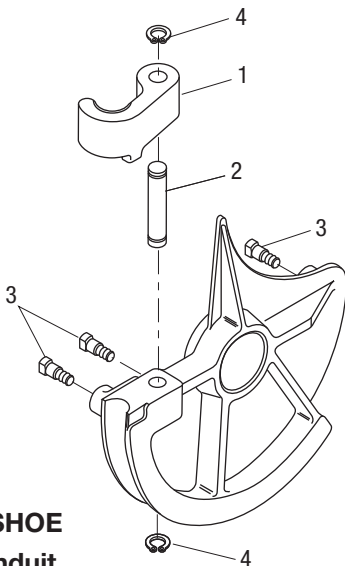
| Key | Part No. | Description | Qty |
|-----|----------|--|-----|
| | 50253631 | Shoe unit, 1-1/2" IMC (includes 1-4) | 1 |
| 1 | 50188119 | Hook, 1-1/2" IMC..... | 1 |
| 2 | 50188372 | Pin, 1-1/2" IMC | 1 |
| 3 | 50234226 | Stud, drive..... | 3 |
| 4 | 90515285 | Ring, Tru-Arc retaining..... | 2 |

**BENDING SHOE
2" EMT Conduit**

| Key | Part No. | Description | Qty |
|-----|----------|--|-----|
| | 50235052 | Shoe unit, 2" EMT conduit (includes 1-4) | 1 |
| 1 | 50188186 | Hook, 2" EMT..... | 1 |
| 2 | 50188429 | Pin, 2" EMT hook | 1 |
| 3 | 50234226 | Stud, drive..... | 3 |
| 4 | 90515293 | Ring, Tru-Arc #5160-87, retaining | 2 |

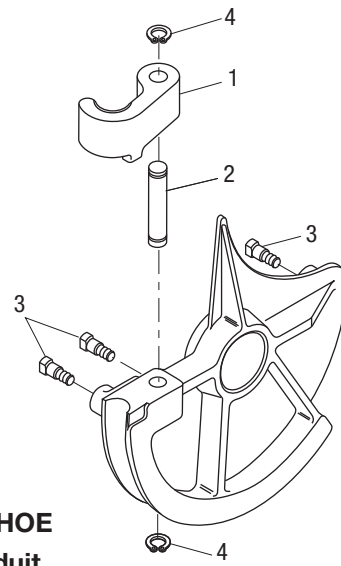
**BENDING SHOE
2" IMC Conduit**

| Key | Part No. | Description | Qty |
|-----|----------|--|-----|
| | 50252682 | Shoe unit, 2" IMC (includes 1-4) | 1 |
| 1 | 50001957 | Hook, 2" IMC..... | 1 |
| 2 | 50188429 | Pin, 2" IMC | 1 |
| 3 | 50234226 | Stud, drive..... | 3 |
| 4 | 90515293 | Ring, Tru-Arc retaining..... | 2 |

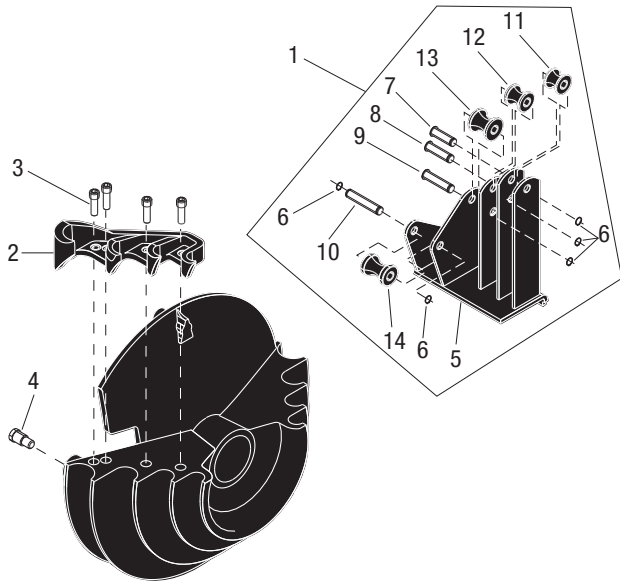
Bending Shoes and Roller Supports (cont'd)

BENDING SHOE AND ROLLER SUPPORT
1/2" to 1-1/4" 40 Mil PVC-Coated Rigid Conduit

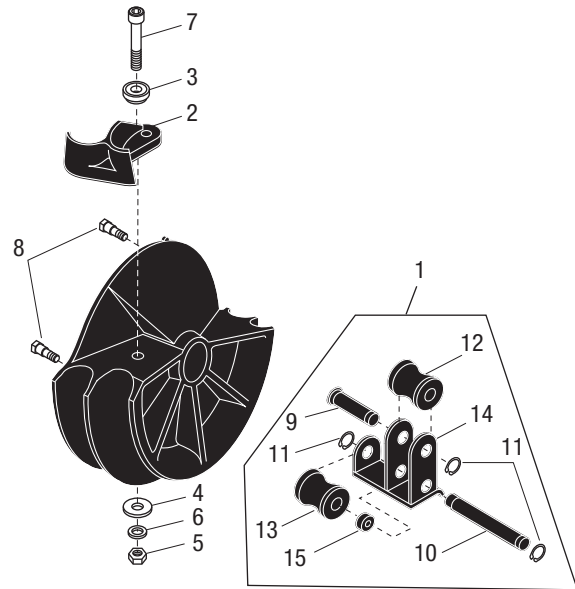
| Key | Part No. | Description | Qty |
|-----|----------|---|-----|
| 1 | 50009460 | Roller support, 1/2" to 1-1/4" PVC-coated rigid (includes 5-14)..... | 1 |
| | 50005731 | Bending shoe assembly, 1/2" to 1-1/4" PVC-coated rigid (includes 2-4) | 1 |
| 2 | 50005707 | Hook..... | 1 |
| 3 | 90510887 | 3/8-16 UNC x 1-1/4" Socket head cap screw..... | 4 |
| 4 | 50234226 | Stud, drive..... | 3 |
| 5 | 50009451 | Support weldment, roller..... | 1 |
| 6 | 90513533 | Retaining ring | 5 |
| 7 | 50009230 | 1/2" Roller axle..... | 1 |
| 8 | 50009249 | 3/4" Roller axle..... | 1 |
| 9 | 50009257 | 1" Roller axle..... | 1 |
| 10 | 50009265 | 1-1/4" Roller axle | 1 |
| 11 | 50009273 | 1/2" Roller | 1 |
| 12 | 50009281 | 3/4" Roller | 1 |
| 13 | 50009290 | 1" Roller..... | 1 |
| 14 | 50009303 | 1-1/4" Roller..... | 1 |

BENDING SHOE AND ROLLER SUPPORT
1-1/2" to 2" 40 Mil PVC-Coated Rigid Conduit

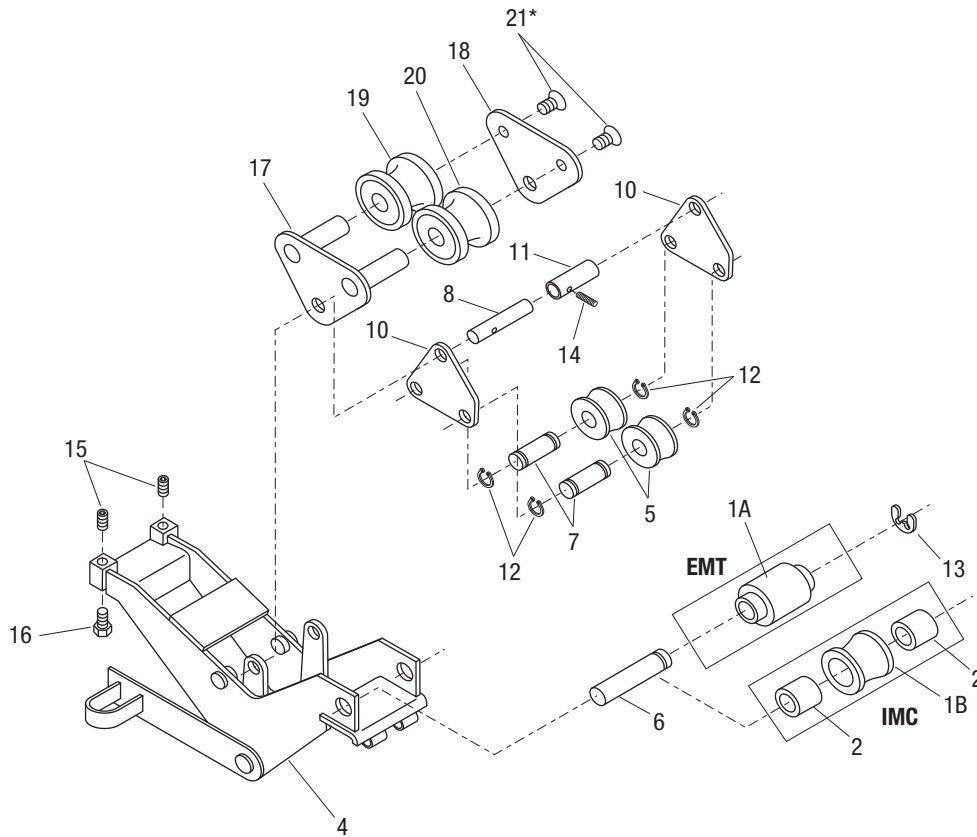
| Key | Part No. | Description | Qty |
|-----|----------|--|-----|
| 1 | 50372823 | Roller support, 1-1/2" to 2" PVC-coated rigid (includes 9-15)..... | 1 |
| | 50372815 | Bending shoe assembly, 1-1/2" to 2" PVC (includes 2-8) | 1 |
| 2 | 50024990 | Hook..... | 1 |
| 3 | 50179748 | Pivot | 1 |
| 4 | 90526759 | 5/8" Flat washer | 1 |
| 5 | 90515692 | 5/8-11 UNC Hex nut..... | 1 |
| 6 | 90509056 | 5/8" Lock washer | 1 |
| 7 | 90524268 | 5/8-11 UNC x 4" socket head cap screw | 1 |
| 8 | 50234226 | Stud, drive..... | 4 |
| 9 | 50376624 | 1-1/2" Shaft..... | 1 |
| 10 | 50376616 | 2" Shaft | 1 |
| 11 | 90515285 | Retaining ring | 3 |
| 12 | 50372840 | 1-1/2" Roller..... | 1 |
| 13 | 50372831 | 2" Roller..... | 1 |
| 14 | 50376640 | Support weldment..... | 1 |
| 15 | 50320254 | Spacer..... | 1 |

Bending Shoes and Roller Supports (cont'd)

EMT ROLLER SUPPORT UNIT

| Key | Part No. | Description | Qty |
|-----|----------|---|-----|
| | 50235419 | Support unit, 1-1/2" and 2" EMT roller (includes all of the following)..... | 1 |
| 1A | 50279831 | Roller unit, cushioned..... | 1 |
| 4 | 50235397 | Frame unit | 1 |
| 5 | 50235109 | Roller, 1-1/2" EMT | 2 |
| 6 | 50235117 | Pin, roller support..... | 1 |
| 7 | 50239325 | Pin, 1-1/2" EMT roller..... | 2 |
| 8 | 50235176 | Pin, roller pivot | 1 |
| 10 | 50235249 | Plate, 1-1/2" EMT pivot..... | 2 |
| 11 | 50237934 | Spacer | 1 |
| 12 | 90515285 | Ring, retaining | 4 |
| 13 | 90524640 | Ring, Tru-Arc #X5133-98 external series "E" retaining | 1 |
| 14 | 90514912 | Rollpin, #59, -040-187-1250 | 1 |
| 15 | 90528484 | Screw, 1/2-13 UNC x 3/4 cup point socket set..... | 2 |
| 16 | 90505425 | Screw, 1/2-13 UNC x 1, hex head cap ... | 2 |
| 17 | 50349643 | Support weldment, 2" roller | 1 |
| 18 | 50349651 | Plate, 2" inner roller support | 1 |
| 19 | 50235192 | Roller, 2" EMT front | 1 |
| 20 | 50237926 | Roller, 2" EMT back..... | 1 |
| 21* | 90533941 | Screw, 7/16-14 UNC x 1, flat head..... | 2 |

IMC ROLLER SUPPORT UNIT

| Key | Part No. | Description | Qty |
|-----|----------|--|-----|
| | 50252739 | Support unit, 1-1/2" and 2" IMC roller (includes 1 and 2)..... | 1 |
| 1B | 50283340 | Roller | 1 |
| 2 | 50283359 | Spacer | 2 |
| 4 | 50263250 | Frame unit | 1 |
| 5 | 50252747 | Roller, 1-1/2" IMC..... | 2 |
| 6 | 50235117 | Pin, roller support..... | 1 |
| 7 | 50239325 | Pin, 1-1/2" IMC roller..... | 2 |
| 8 | 50235176 | Pin, roller pivot | 1 |
| 10 | 50235249 | Plate, 1-1/2" IMC pivot..... | 2 |
| 11 | 50237934 | Spacer | 1 |
| 12 | 90515285 | Ring, retaining | 4 |
| 13 | 90524640 | Ring, Tru-Arc #X5133-98 external series "E" retaining | 1 |
| 14 | 90514912 | Rollpin, #59, -040-187-1250 | 1 |
| 15 | 90528484 | Screw, 1/2-13 UNC x 3/4 cup point socket set..... | 2 |
| 16 | 90505425 | Screw, 1/2-13 UNC x 1, hex head cap ... | 2 |
| 17 | 50349643 | Support weldment, 2" roller | 1 |
| 18 | 50349651 | Plate, 2" inner roller support | 1 |
| 19 | 50252798 | Roller, 2" IMC | 2 |
| 21* | 90533941 | Screw, 7/16-14 UNC x 1, flat head..... | 2 |

*Key No. 21 must be torqued to 54 to 61 Newton-meters (40 to 45 ft-lb).



4455 Boeing Drive • Rockford, IL 61109-2988 • USA • 815-397-7070
An ISO 9001 Company • Greenlee Textron Inc. is a subsidiary of Textron Inc.
www.greenlee.com

USA Tel: 800-435-0786
Fax: 800-451-2632

Canada Tel: 800-435-0786
Fax: 800-524-2853

International Tel: +1-815-397-7070
Fax: +1-815-397-9247