



Click Here To View
Item at

www.GapPower.com

*Sales • Rentals
Parts & Service*

Replacement Parts Diagrams *300 Series Hole Diggers*

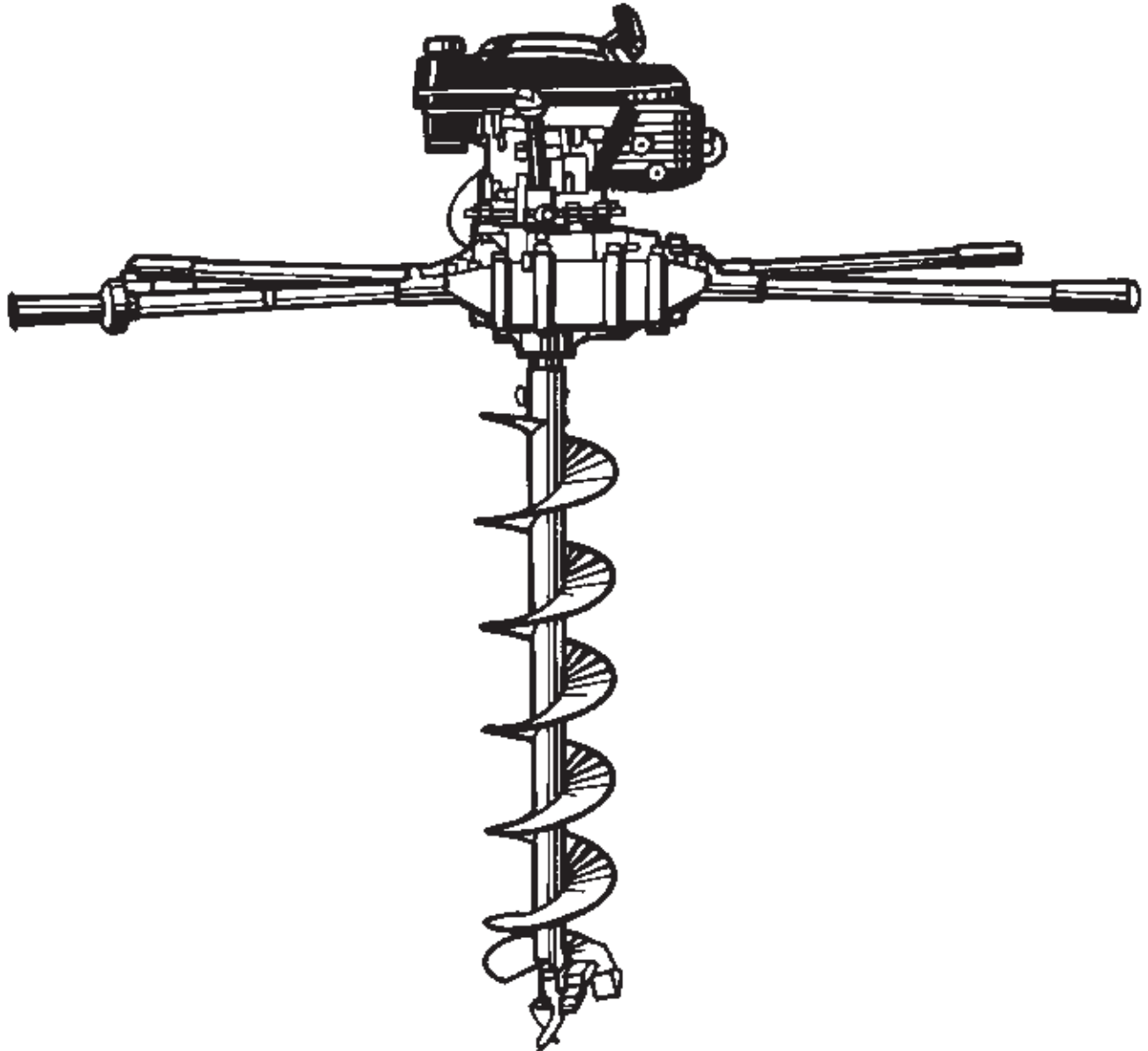

**Replacement Parts Diagram
Plastic Series 314
Magura® Throttle Control Assembly
300 Series Hole Diggers**

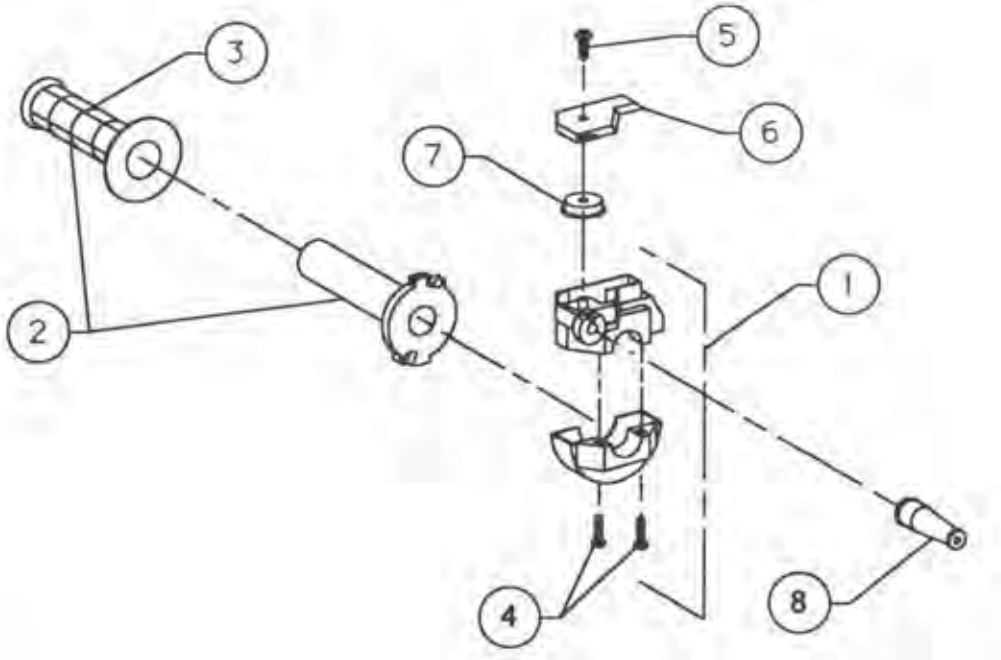

**Replacement Parts Diagram
Plastic Series 314
Magura® Throttle Control Assembly
300 Series Hole Diggers**

Reference Number	PART NUMBER	DESCRIPTION	QUANTITY
1	310-0030-010-A	Body Assembly, (Includes P/N 310-0030-040, Qty 2)	1
2	310-0030-020-A	Tube, Throttle (Includes P/N 310-0020-030)	1
3	310-0020-030	Grip, Handle	1
4	310-0030-040	Screw, Pan Head, M5 x 20	2
5	310-0030-050	Screw, Self Tapping	1
6	310-0030-060	Cover, Top	1
7	310-0030-070	Sheave, Roller	1
8	310-0020-080	Boot, Rubber	1

Replacement Parts Diagram Operator Handle Assemblies 300 Series Hole Diggers

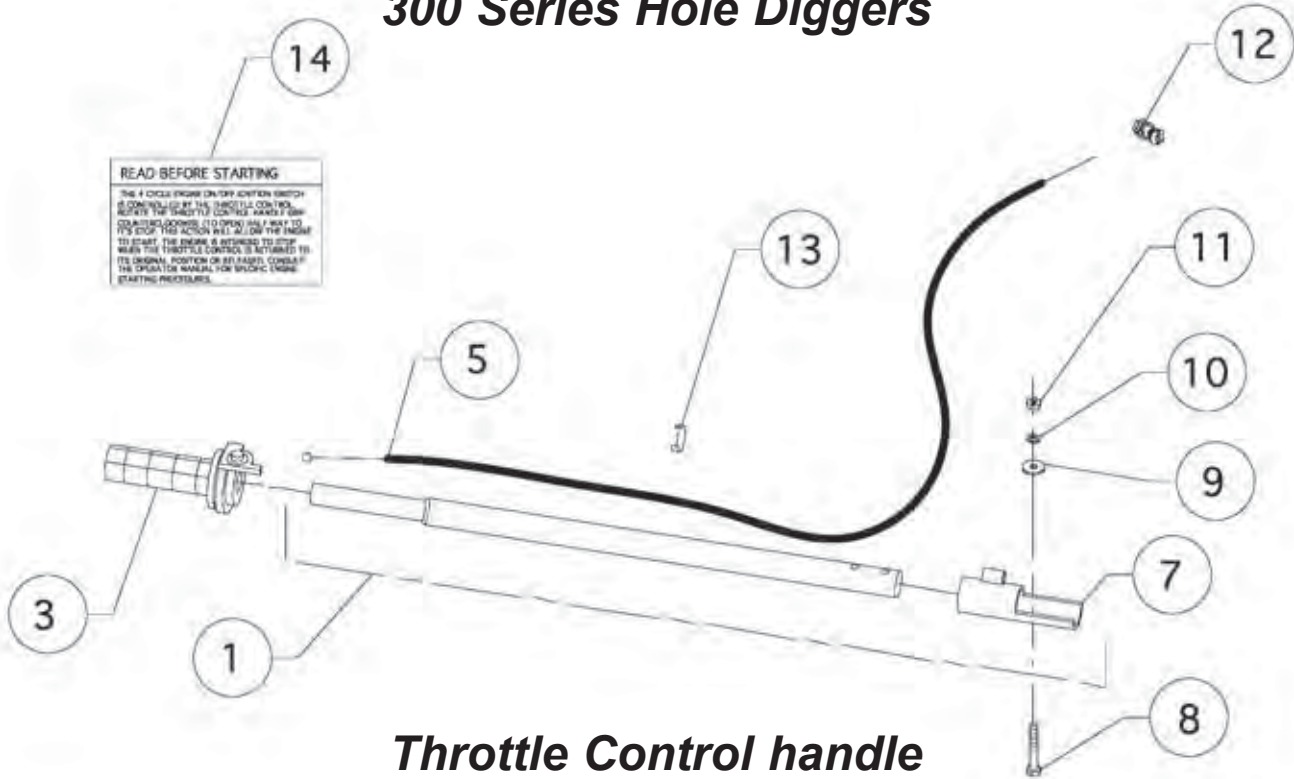

**Throttle Control handle
One Assembly Per Machine**

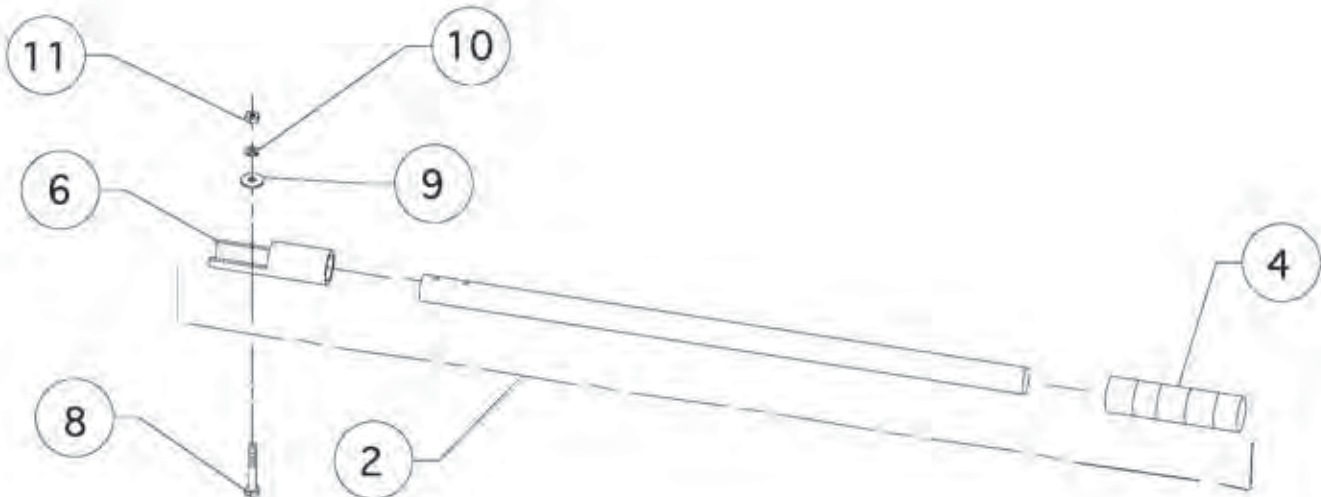

**Operator handle
Three Assemblies Per Machine**

Replacement Parts Diagram Handle Assemblies 300 Series Hole Diggers

Reference Number	PART NUMBER	DESCRIPTION	QUANTITY
1	310-0091-A	Handle, Throttle (Includes P/N 310-0012)	1
2	310-0092-A	Handle, Operator (Includes P/N 310-0011 & P/N 330-0070)	3
3	310-0030	Throttle, Twist Control, Plastic, Complete	1
4	330-0070	Grip, Handle	3
5	310-0081	Cable, Throttle	1
6	310-0011	Tube, Handle Brace	3
7	310-0012	Tube, Handle Brace (Throttle)	1
8	15051800	Screw, Cap, 5/16" x 2-1/4" UNC, Grade 5, Plated	8
9	17040000	Washer, Flat, 1/4", Plated	8
10	16050000	Washer, Lock, 5/16", Plated	8
11	18050000	Nut, Hex, 5/16" UNC, Plated	8
12	WS-277	Assembly, Swivel	1
	330-0320	Assembly, Swivel (GXV160 Honda Engine Only)	1
13	CC-1	Clip, Throttle	1
14	330H-5040	Decal, Ignition (Used On Four Cycle Engines Only)	1

Engine And Cover Assembly
330H, 343H, & 357H Hole Diggers
Equipped with Honda GXV160 Engine
[Used Starting With 330H Serial Number 33022419]
[Used Starting With 343H Serial Number 27263]
[Used Starting With 357H Serial Number 26019]

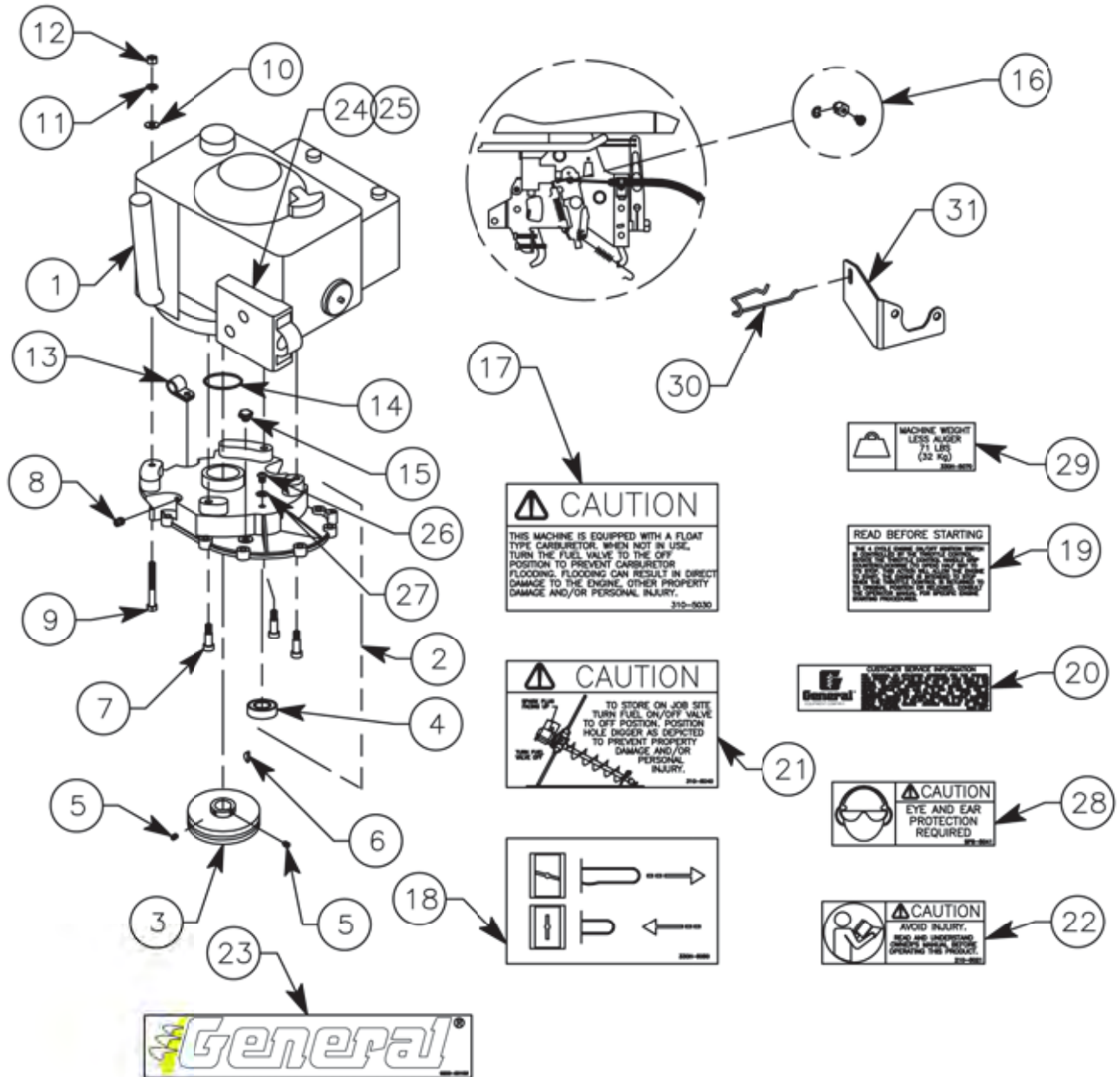

Engine And Cover Assembly
330H, 343H, & 357H Hole Diggers
Equipped with Honda GXV160 Engine
[Used Starting With 330H Serial Number 33022419]
[Used Starting With 343H Serial Number 27263]
[Used Starting With 357H Serial Number 26019]

Reference Number	PART NUMBER	DESCRIPTION	QUANTITY
1	GXV160 Replace	Engine, Honda (5.5 HP)	1
2	330-0136-A	Cover, Transmission (Includes P/N 6203-2RS-12)	1
3	330H-0175	Rotor And Shoe Assembly, Clutch	1
4	6203-2RS-12	Bearing, Ball	1
5	31040201	Screw, Set, Cup, 1/4-28 x 1/4"	2
6	6	Key, Woodruff, 5/32" x 5/8", Alloy	1
7	62060601	Bolt, Shoulder, (3/8" x 3/4" x 5/16-24 UNF)	3
8	74020201	Plug, Pipe, 1/8-27 PTF	1
9	15051800	Screw, Cap, 5/16-18 UNC x 2-1/4", Plated	1
10	AN-960-516L	Washer, AN Type, 5/16", Plated	1
11	16050000	Washer, Lock, 5/16", Plated	1
12	18050000	Nut, Hexagon, 5/16", Plated	1
13	COV-0411	Clamp, Plated	1
14	330H-0020	"O" Ring	1
15	5677	Valve, Pressure Release	1
16	330-0320	Swivel Assembly	1
17	310-0531	Decal, Danger	1
18	330H-5030	Decal, Warning	1
19	330H-5040	Decal, Choke	1
20	SG24-5072	Decal, Ignition	1
21	310-5041	Decal, Assistance	1
22	210-5021	Decal, Danger	1
23	GECD-5010W	Decal, (General)	1
24	330H-0310	Muffler (Modified)	1
25	330H-0340	Guard, Muffler (Modified)	1
26	37050300	Screw, Panhead, Phillips, 5/16-18 UNC x 3/8", Plated	1
27	330H-0200	Washer, Plastic	1
28	SP8-5041	Decal, Caution	1
29	330H-5070	Decal, Weight	1
30	16611-ZG9-U80	Rod, Choke Lever	1
31	17954-ZG9-U80	Bracket, Choke Lever	1

Replace: GXV160 KIT

Used for converting a GXV140 Honda equipped M330H Digger to a GXV160 Honda engine.
(Includes reference numbers above: 1,2,3,6,7,9,11,12,14,15,26,27)



Transmission Assembly
330H, 343H, & 357H Hole Diggers
Equipped with Honda GXV160 Engine
[Used Starting With 330H Serial Number 33022419]
[Used Starting With 343H Serial Number 27263]
[Used Starting With 357H Serial Number 26019]

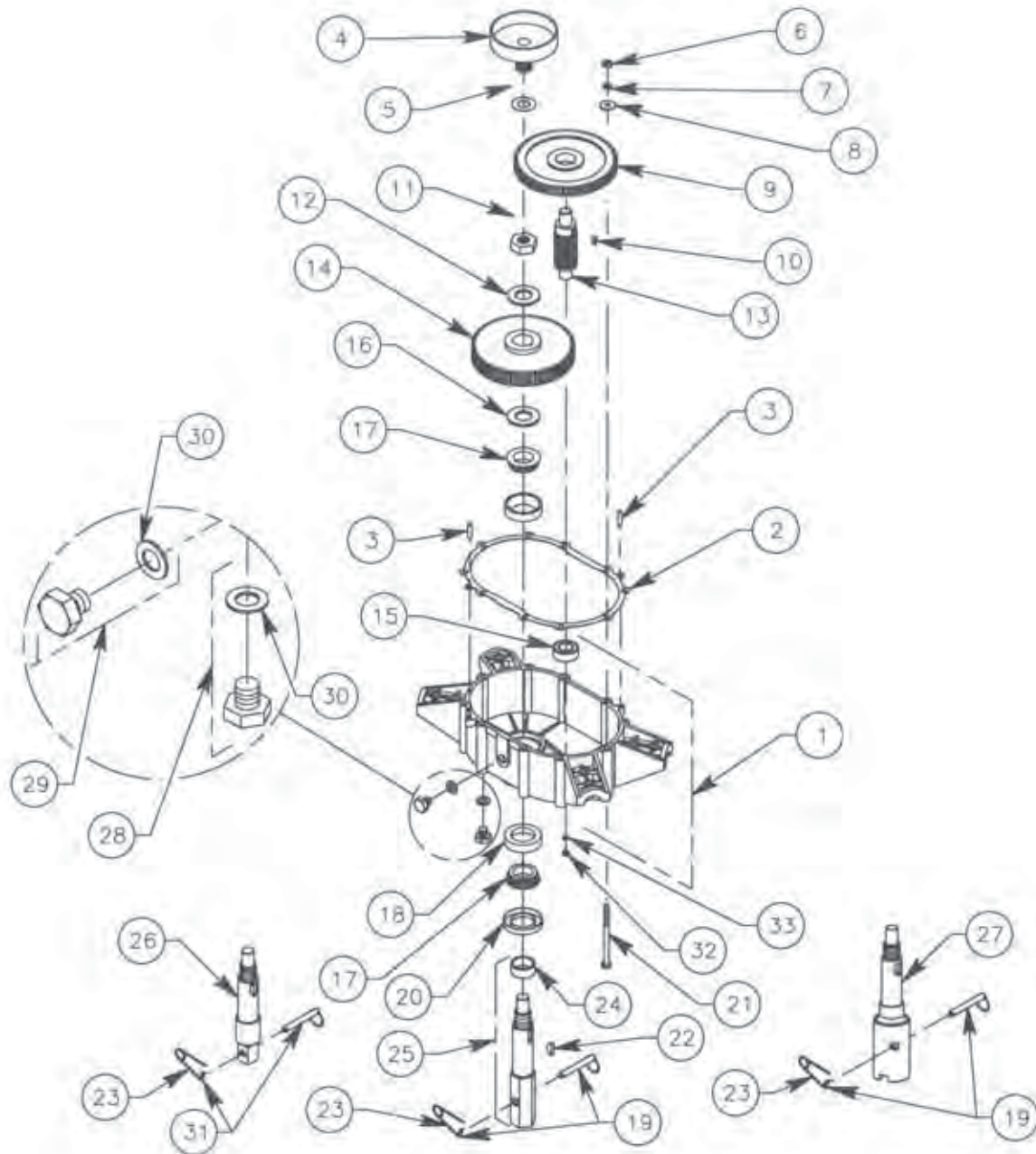

Transmission Assembly
330H, 343H, & 357H Hole Diggers
Equipped with Honda GXV160 Engine
[Used Starting With 330H Serial Number 33022419]
[Used Starting With 343H Serial Number 27263]
[Used Starting With 357H Serial Number 26019]

Reference Number	PART NUMBER	DESCRIPTION	QUANTITY
1	310-0121-A	Case, Transmission (Includes P/N 6203-2RS-12 and 08231)	1
2	310-0101	Gasket, Transmission	1
3	51040800	Pin, Dowel, 1/4" x 1	2
4	3516	Drum And Pinion Assembly, Clutch	1
5	200682	Washer, Fiber	1
6	18050000	Nut, Hex, 5/16" UNC, Plated	10
7	16050000	Washer, Lock, 5/16", Plated	10
8	AN-960-516L	Washer, AN Type, 5/16", Plated	10
9	7034	Gear, Primary	1
10	6	Key, Woodruff, 5/32" x 5/8", Alloy	1
11	19160001	Nut, Hex, 1"-14 UNF, Self-Locking	1
12	17160000	Washer, Flat, 1", Plain Finish	1
13	345-0310	Gear, Pinion	1
14	345-0350	Gear, Secondary	1
15	6203-2RS-12	Bearing, Ball	2
16	08125/08231B-AV	Ring, Nilos®	1
17	08125	Cone, Bearing	2
18	08231	Cup, Bearing	2
19	2121	Pin, Auger, General and Stihl (Includes P/N AP-21-S)	1
20	471820	Seal, Oil	1
21	15053600	Screw, Cap, 5/16" x 4 1/2" UNC, Grade 5, Plated	10
22	15	Key, Woodruff, 1/4" x 1", Alloy	1
23	AP-21-S	Pin, Safety	1
24	345-0332-020	Bushing	1
25	330H-0330-A	Shaft, Drive, 1 3/8" Hexagon, 6 Sided (Includes P/N 345-0332-020)	1
26	343H-0330	Shaft, Drive, 7/8" Square, Ground Hog Type (P/N 345-0332-020 Not Required)	1
27	357H-0330	Shaft, Drive, Stihl Type Drive (P/N 345-0332-020 Not Required)	1
28	50100800	Plug, Oil Drain (Includes P/N 66044)	1
29	50100801	Plug, Oil Level (Includes P/N 66044)	1
30	66044	Gasket, Oil Plug	2
31	2021	Pin, Auger, Ground Hog Type, 7/8" Square (Includes P/N AP-21-S)	1
32	37050300	Screw, Panhead, Phillips, 5/16-18 UNC x 3/8", Plated	1
33	330H-0200	Washer, Plastic	1



Replacement Parts Diagrams 4400 Series Earth Augers 1-3/8" Hexagon Drive Connection For Use With 330 Series Hole Diggers

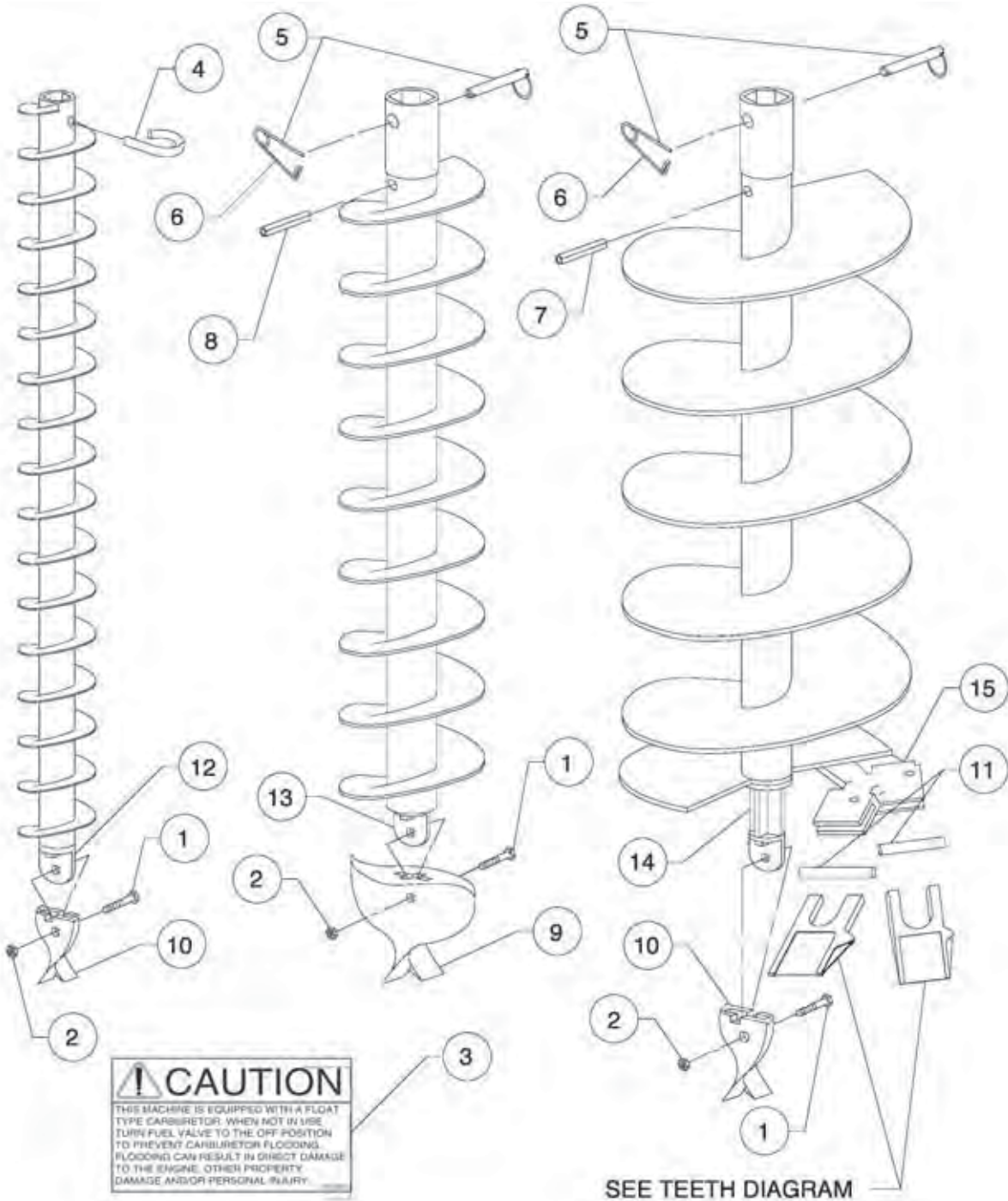

Replacement Parts Diagrams 4400 Series Earth Augers 1-3/8" Hexagon Drive Connection For Use With 330 Series Hole Digger

Reference Number	PART NUMBER	DESCRIPTION	APPLICATION	QUANTITY
1	15051200	Screw, Cap, 5/16" x 1 1/2" UNC, Plated	All Augers	1
2	18050000	Nut, Hex, 5/16" UNC, Plated	All Augers	1
3	233-5092	Decal, Danger	All Augers	1
4	DP-2	Pin, Drive	4400-2E3 Auger	1
			5500-2X3 Extension	1
	DP-3	Pin, Drive	4400-3E3 Auger	1
			4410-4E3 Auger	1
			5500-3X3 Extension	1
			5510-4X3 Extension	1
5	2121	Pin, Auger (Includes P/N AP-21-S)	4400-4E3 thru 4400-18P Augers	1
			5500-15X Extension	1
			5500-4E3 thru 5500-12E3 Extensions	1
6	AP-21-S	Pin, Safety	4400-4E3 thru 4400-18P Augers	1
			5500-15X Extension	1
			5500-4E3 thru 5500-12E3 Extensions	1
7	20052000	Pin, Roll, 5/16" x 2-1/2", Plain Finish	4400-12E3 thru 4400-18P Augers	1
			5500-12X3 Extension	1
8	20051600	Pin, Roll, 5/16" x 2", Plain Finish	4400-4E3 thru 4400-10E3 Augers	1
			5500-4X3 thru 5500-10X3 Extensions	1
			5500-15X Extension	1
9	SB35	Bit, Screw	4400-3E3 Auger	1
	SB45	Bit, Screw	4400-4E3 and 4410-4E3 Augers	1
10	SB25	Bit, Screw	4400-2E3 Auger	1
			4400-6E3 thru 4400-18P Augers	1
11	RL	Lock, Rubber	4400-6E3 thru 4400-18P Augers	As Req



Replacement Parts Diagrams
4400 Series Earth Augers
1-3/8" Hexagon Drive Connection
For Use With 330 Series Hole Diggers

Reference Number	PART NUMBER	DESCRIPTION	APPLICATION	QUANTITY
12	140S	Lug, Drive (Weld On)	4400-2E3 Auger	1
13	141M	Lug, Drive (Weld On)	4400-3E3 Auger 4400-4E3 and 4410-4E3 Augers	1
14	140CS	Lug, Drive (Weld On)	4400-6E3 thru 4400-18P Augers	1
15	6CS	Shank, 6" (Weld On)	4400-6E3 Auger 4400-16E3 and 4400-18P Augers	1
	8CS	Shank, 8" (Weld On)	4400-8E3 Auger	1
	12CS	Shank, 12" (Weld On)	4400-10E3 and 4400-12E3 Augers 4400-16E3 and 4400-18P Augers	1
				2



Left Blank Intentionally



Replacement Parts Diagrams PSD Series Earth Augers 7/8" Square (Ground Hog) Drive Connection For Use With 343 Series Hole Diggers

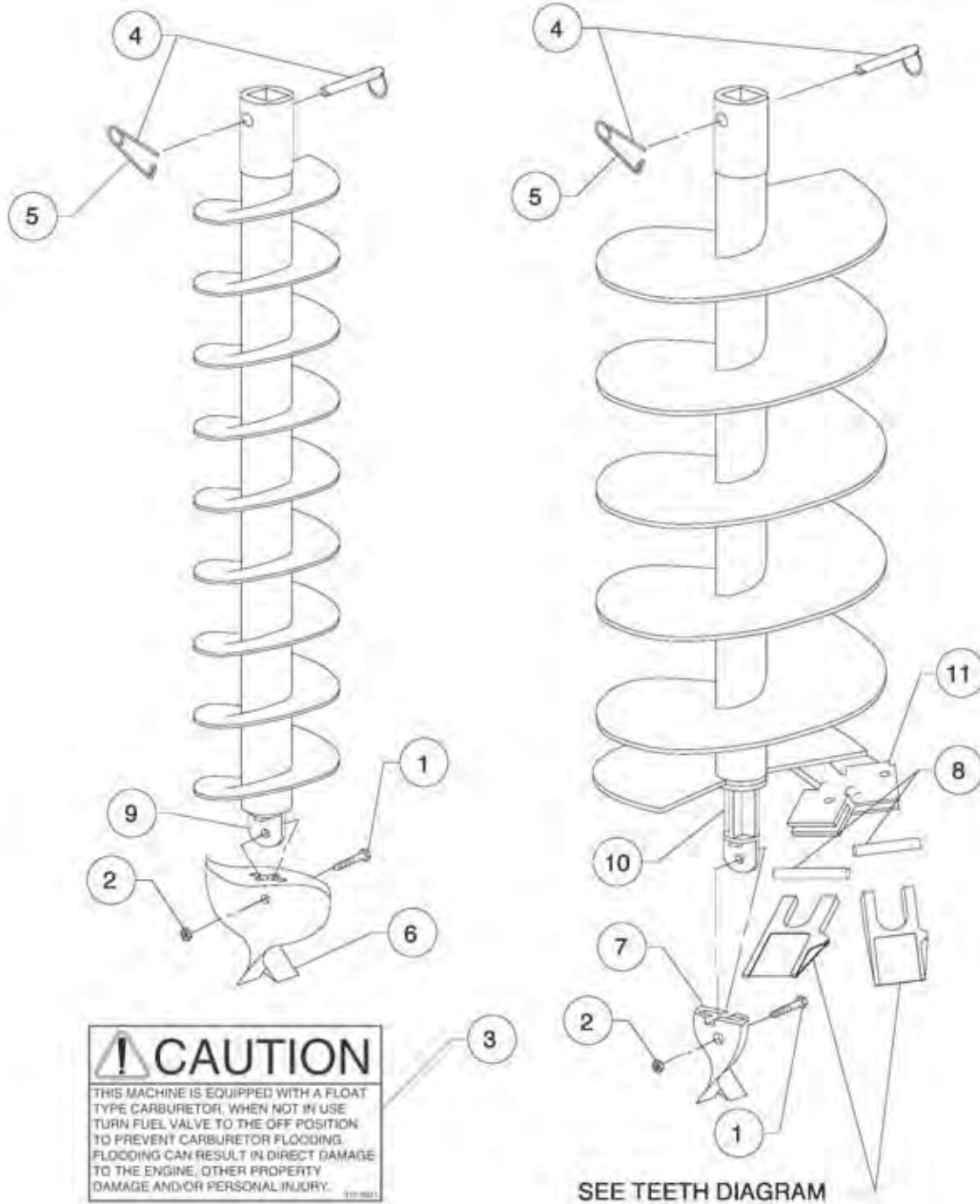

Replacement Parts Diagrams
PSD Series Earth Augers
7/8" Square (Ground Hog) Drive Connection
For Use With 343 Series Hole Diggers

Reference Number	PART NUMBER	DESCRIPTION	APPLICATION	QUANTIT Y
1	15051200	Screw, Cap, 5/16" x 1 1/2" UNC, Plated	All Augers	1
2	18050000	Nut, Hex, 5/16" UNC, Plated	All Augers	1
3	233-5092	Decal, Danger	All Augers	1
4	2021	Pin, Auger (Includes P/N AP-21-S)	All Augers	1
			PSD-15X Extension	1
5	AP-21-S	Pin, Safety	All Augers	1
			PSD-15X Extension	1
6	SB45	Bit, Screw	PSD4 Auger	1
7	SB25	Bit, Screw	PSD6 thru PSD12	
			Augers	1
8	RL	Lock, Rubber	PSD6 thru PSD12	
			Augers	As Req
9	141M	Lug, Drive (Weld On)	PSD4 Auger	1
10	140CS	Lug, Drive (Weld On)	PSD6 thru PSD12	
			Augers	1
11	6CS	Shank, 6" (Weld On)	PSD6 Auger	1
	8CS	Shank, 8" (Weld On)	PSD8 Auger	1
	12CS	Shank, 12" (Weld On)	PSD10 and PSD12 Augers	1



Replacement Parts Diagrams BT360 Series Earth Augers Stihl Type Drive Connection For Use With 357 Series Hole Diggers

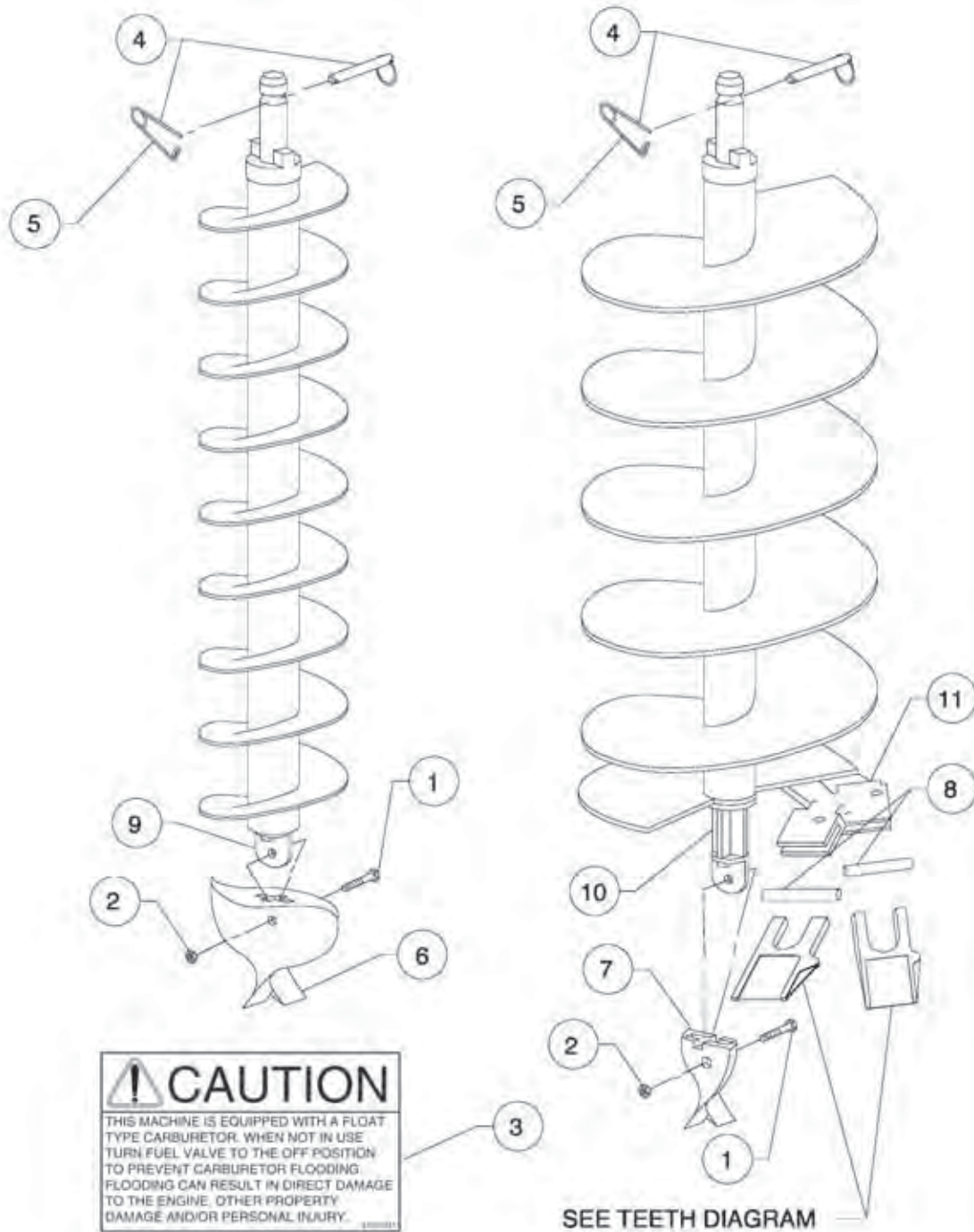

Replacement Parts Diagrams
BT360 Series Earth Augers
Stihl Type Drive Connection
For Use With 357 Series Hole Diggers

Reference Number	PART NUMBER	DESCRIPTION	APPLICATION	QTY
1	15051200	Screw, Cap, 5/16" x 1 1/2" UNC, Plated	All Augers	1
2	18050000	Nut, Hex, 5/16" UNC, Plated	All Augers	1
3	233-5092	Decal, Danger	All Augers	1
4	2121	Pin, Auger (Includes P/N AP-21-S)	All Augers	1
			BT360-15X Extension	1
5	AP-21-S	Pin, Safety	All Augers	1
			BT360-15X Extension	1
6	SB45	Bit, Screw	BT360-4E Auger	1
7	SB25	Bit, Screw	BT360-6E thru BT360-18P Augers	1
8	RL	Lok, Rubber	BT360-6E thru BT360-18P Augers	As Req
9	141M	Lug, Drive (Weld On)	BT360-4E Auger	1
10	140CS	Lug, Drive (Weld On)	BT360-6E thru BT360-18P Augers	1
11	6CS	Shank, 6" (Weld On)	BT360-6E And BT360-18P Augers	1
	8CS	Shank, 8" (Weld On)	BT360-8E Auger	1
	12CS	Shank, 12" (Weld On)	BT360-10E and BT360-12E Augers	1
			BT360-18P Augers	2



Replacement Teeth Diagrams For Use With 4400, PSD, And BT360 Series Earth Augers

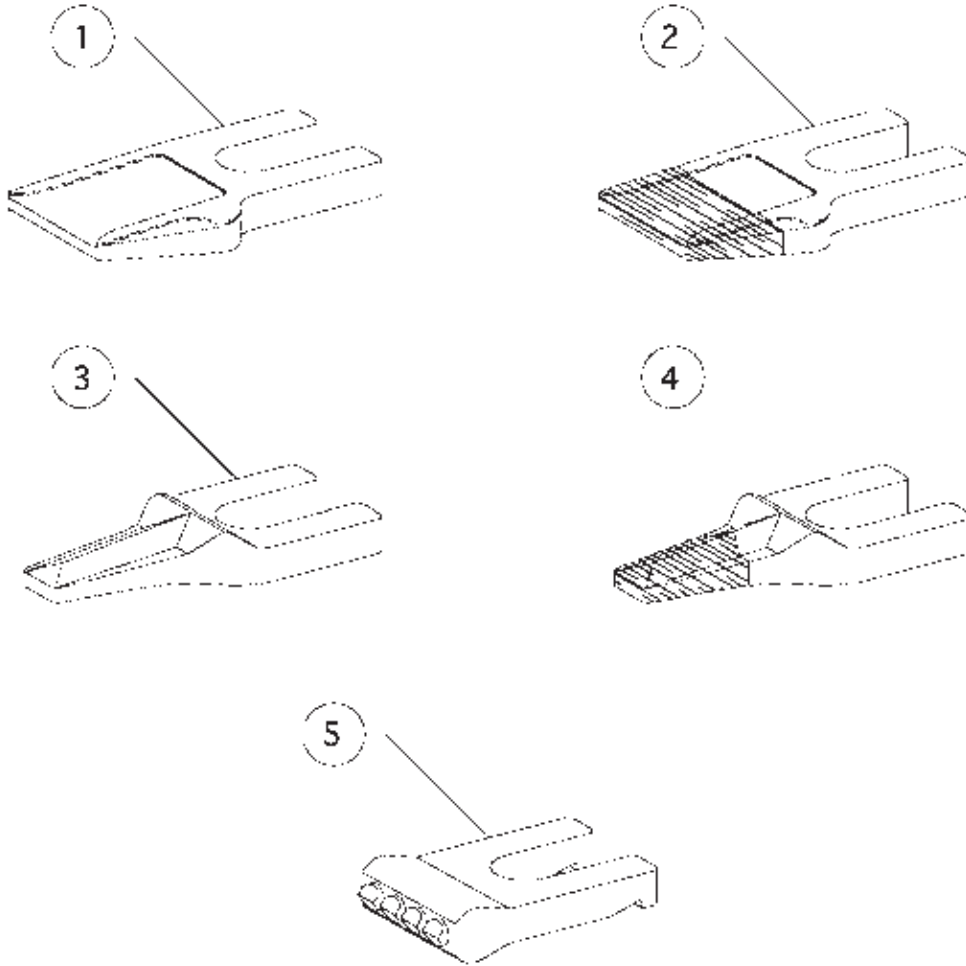

REFERENCE NUMBER	PART NUMBER	DESCRIPTION	QUANTITY
1	35	Dirt Tooth, Standard	As Required
2	35HFC	Dirt Tooth, Hard Faced	As Required
3	5T30	Tooth, Chisel	As Required
4	5T30C	Tooth, Chisel, Hard Faced	As Required
5	1336	Tooth, Tungsten Carbide	As Required

Consult The Service Section Of This Manual For Specific Application Information



Replacement Parts Diagram Display Stand Assembly 300 Series Hole Diggers

*This drawing represents display stands
(including variations) for the 300 Series Hole Diggers*

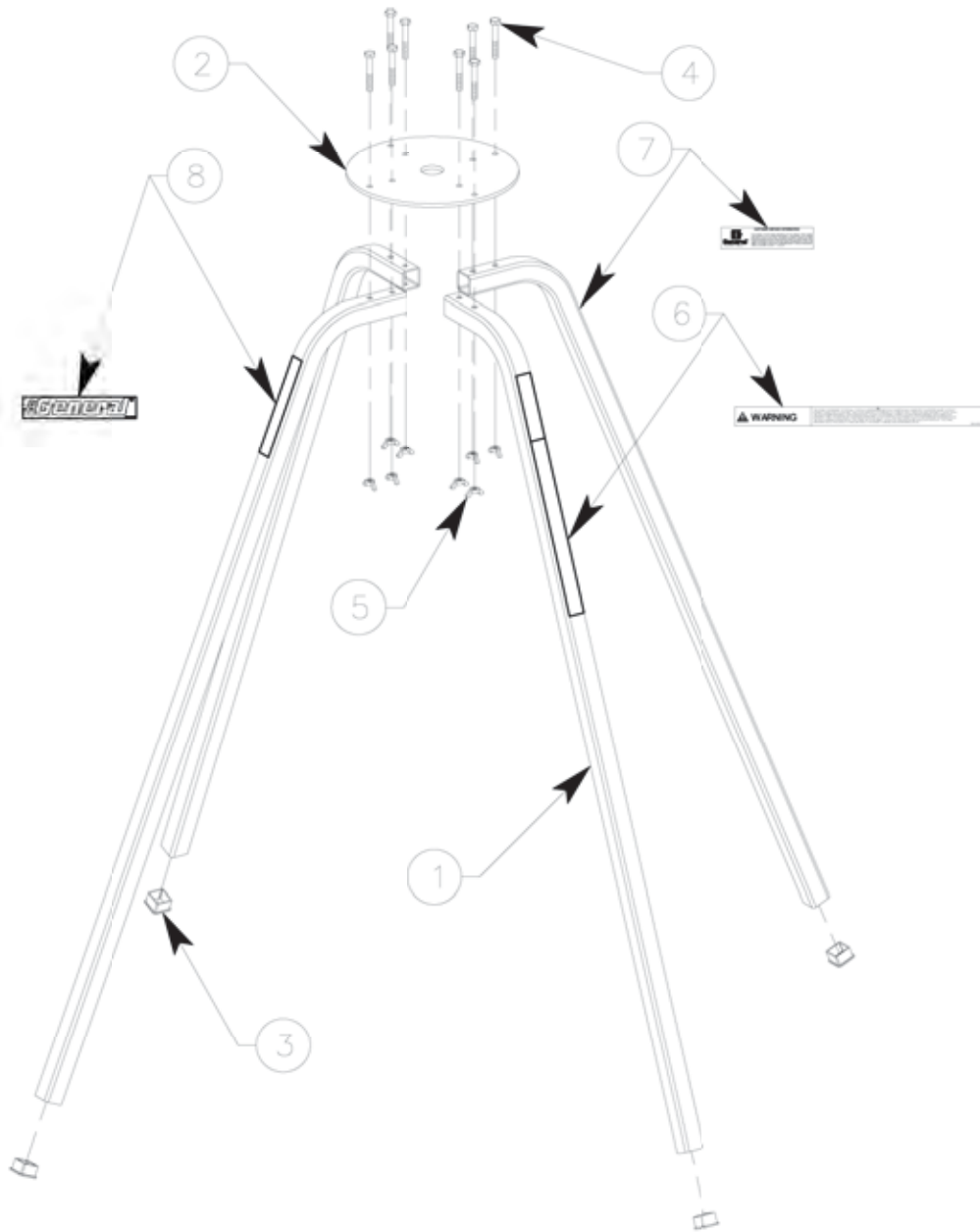

Replacement Parts Diagram Display Stand Assembly 300 Series Hole Diggers

Reference Number	PART NUMBER	DESCRIPTION	QUANTITY
1	999-4-010	Leg, Stand (210 Hole Digger)	4
	999-5-010	Leg, Stand (300 Series Hole Diggers)	4
2	999-4-020	Plate, Top (210 Hole Digger)	1
	999-5-020	Plate, Top (310, 330, 342 & 343 Hole Diggers)	1
	999-12-020	Plate, Top (356 & 357 Hole Diggers)	1
3	FP-164	Cap, Plug, 1" Square	4
4	15041400	Screw, Cap, 1/4-20 UNC x 1-3/4", Plated	8
5	43040000	Nut, Wing, 1/4-20 UNC, Plated	8
6	999-4-5010	Decal, Warning	1
7	SG24-5070	Decal, Assistance	1
8	GECD-5010W	Decal, General	1

