



Count on it.

Parts Catalog

20in Turf Seeder

Model No. 23510—Serial No. 315000001 and Up

Model No. 33510—Serial No. 315000001 and Up



Ordering Replacement Parts

To order replacement parts, please supply the part number, the quantity, and the description of each part desired.

Understanding Reference Numbers

Each identified part in an illustration has a reference number. The reference number for a part also appears in the parts list, along with other information about the part.

This catalog uses two special reference number formats, one to indicate parts in a service assembly and another to indicate the quantity of a given part in an illustration.

Service Assembly Reference Numbers

Parts in service assemblies have reference numbers in the form a:b. The a represents the reference number of the entire service assembly and the b represents a sequential number unique to each part within the service assembly.

For example, a wheel assembly might be identified by reference number 6, the tire by 6:1, the valve by 6:2, and the wheel by 6:3. When you order the assembly identified by reference number 6, you receive all parts identified by reference numbers 6:1, 6:2, and 6:3. However, you may also order any part individually. Reference numbers of this type appear in illustration and in parts lists.

Reference Numbers Indicating Quantity

In an illustration, if a reference number indicates more than one part, the reference number has the form nX y. The n represents the quantity of the part, the X is the multiplication symbol, and the y represents the reference number.

For example, in an illustration, the reference number 2X 37 means that two of the parts identified by reference number 37 are indicated.

List of Abbreviations

AR: as required

ASM: assembly

BBC: blade brake control

BHTF: button head thread forming

CARR: carriage

CCW: counter clockwise

CW: clockwise

DEG: degrees

DPA: Dual Point Adjustment

ECM: electronic control module

EXT: external

FH: flat head

GA: gauge

HD: heavy-duty

HF: hex flange

HH: hex head

HHF: hex head flange

HHFTF: hex head flange thread forming

HJ: hex jam

HLH: hex lag head

HOC: height-of-cut

HP: high pressure

HSBH: hex socket button head

HSFH: hex socket flat head

HSH: hex socket head

HWH: hex washer head

HWHTF: hex washer head thread forming

HYD: hydraulic

LH: left hand

LP: low pressure

LPG: Liquefied Petroleum Gas

NI: nylon insert

NPTF: national pipe thread fine

PFH: phillips flat head

PPH: phillips pan head

PPHTF: phillips pan head thread forming

PRH: phillips round head

PTH: phillips truss head

PTO: power-take-off

RH: right hand

ROPS: roll-over protection system

RRB: rear roller brush

SFH: slotted fillister head

SHH: slotted hex head

SHWH: slotted hex washer head

SPH: slotted pan head

SQH: square head

SRH: slotted round head

STD: standard

TAP: self tapping

TTH: torx truss head

Contents

Engine and Frame Assembly	4
Main Frame Assembly No. 121-6196	6
Handle Assembly	8
Cutting Wheel Assembly	10
Shaft Assembly No. 126-0034	12
Seed Gate Assembly	14
Belt Drive Assembly	16
Transmission Assembly	18

Engine and Frame Assembly

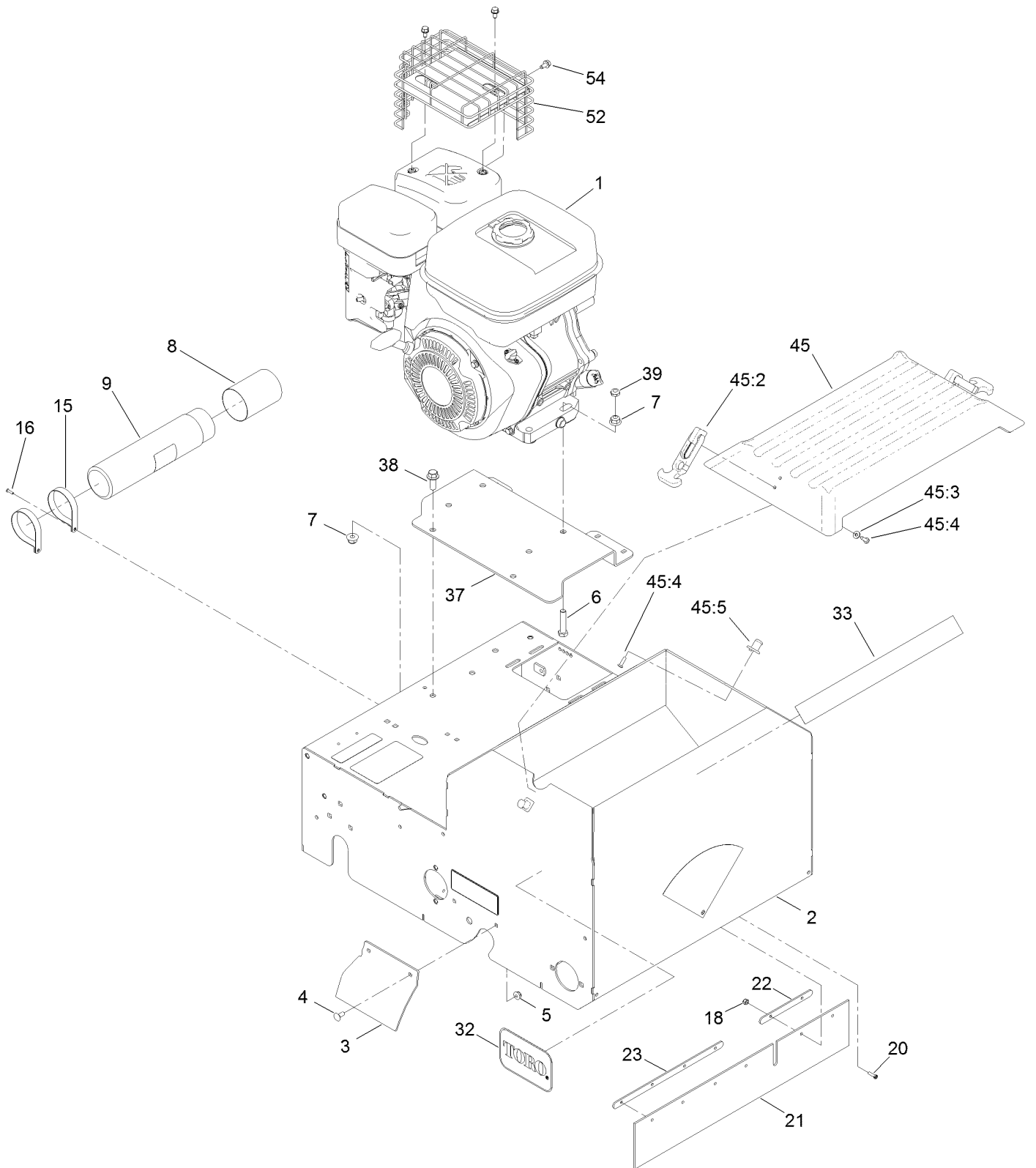

Engine and Frame Assembly (continued)

<i>Ref.</i>	<i>Part Number</i>	<i>Qty.</i>	<i>Description</i>	<i>Ref.</i>	<i>Part Number</i>	<i>Qty.</i>	<i>Description</i>
1		1	Engine-Subaru, Ex27 ●	22	121-1991	1	Plate-Retainer
2	121-6196	1	Frame ASM	23	121-1992	1	Plate-Retainer
3	121-1896-01	1	Guard-RH	32	67-1300	2	Decal
4	3229-11	2	Screw-CARR	33	121-6177	1	Decal
5	104-7201	2	Nut-Flange, NI	37	116-9524-01	1	Plate-Engine
6	323-9	4	Screw-HH	38	3234-42	3	Screw-HHF
7	104-8301	7	Nut-Flange, NI	39	3296-59	1	Nut-Lock, NI
8	104-7048	1	Cap-Housing	45	126-1665	1	Seeder Cover Kit
9	104-7050	1	Tube-Manual	45:2	103-4080	2	Latch-Rubber
15	2412-120	2	Clamp-R	45:3	3256-14	4	Washer-Flat
16	3269-17	2	Rivet-Pop	45:4	3290-500	6	Screw-PPH
18	3296-1	6	Nut-Lock	45:5	103-4081	2	Latch-Keeper
20	3290-392	6	Screw-SHH	52	126-4255	1	Guard, Muffler
21	121-1990	1	Guard-Dust	54	104-2628	3	Screw-HWH

● Not serviced separately

Main Frame Assembly No. 121-6196

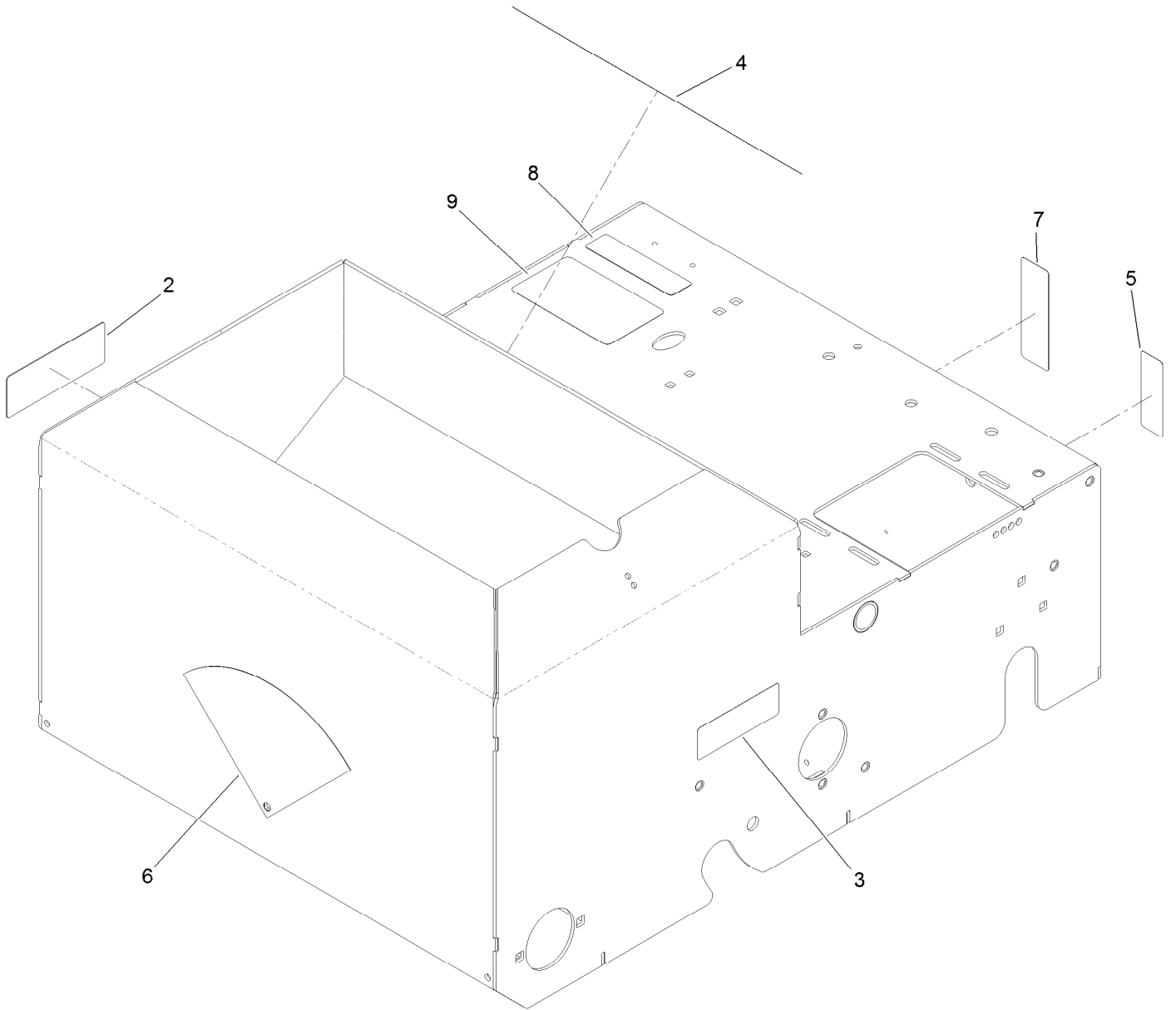

Main Frame Assembly No. 121-6196 (continued)

<i>Ref.</i>	<i>Part Number</i>	<i>Qty.</i>	<i>Description</i>	<i>Ref.</i>	<i>Part Number</i>	<i>Qty.</i>	<i>Description</i>
2	93-7321	1	Decal-Danger	6	116-8535	1	Decal-Flow, Seed
3	117-4979	1	Decal-Warning, Shields	7	121-6203	1	Decal-Bypass
4	121-2011	1	Decal-Warning	8	117-2718	1	Decal-Arrester, Spark
5	115-9625	1	Decal-Brake, Parking	9	126-0296	1	Decal-Service Aid Seeder

Handle Assembly

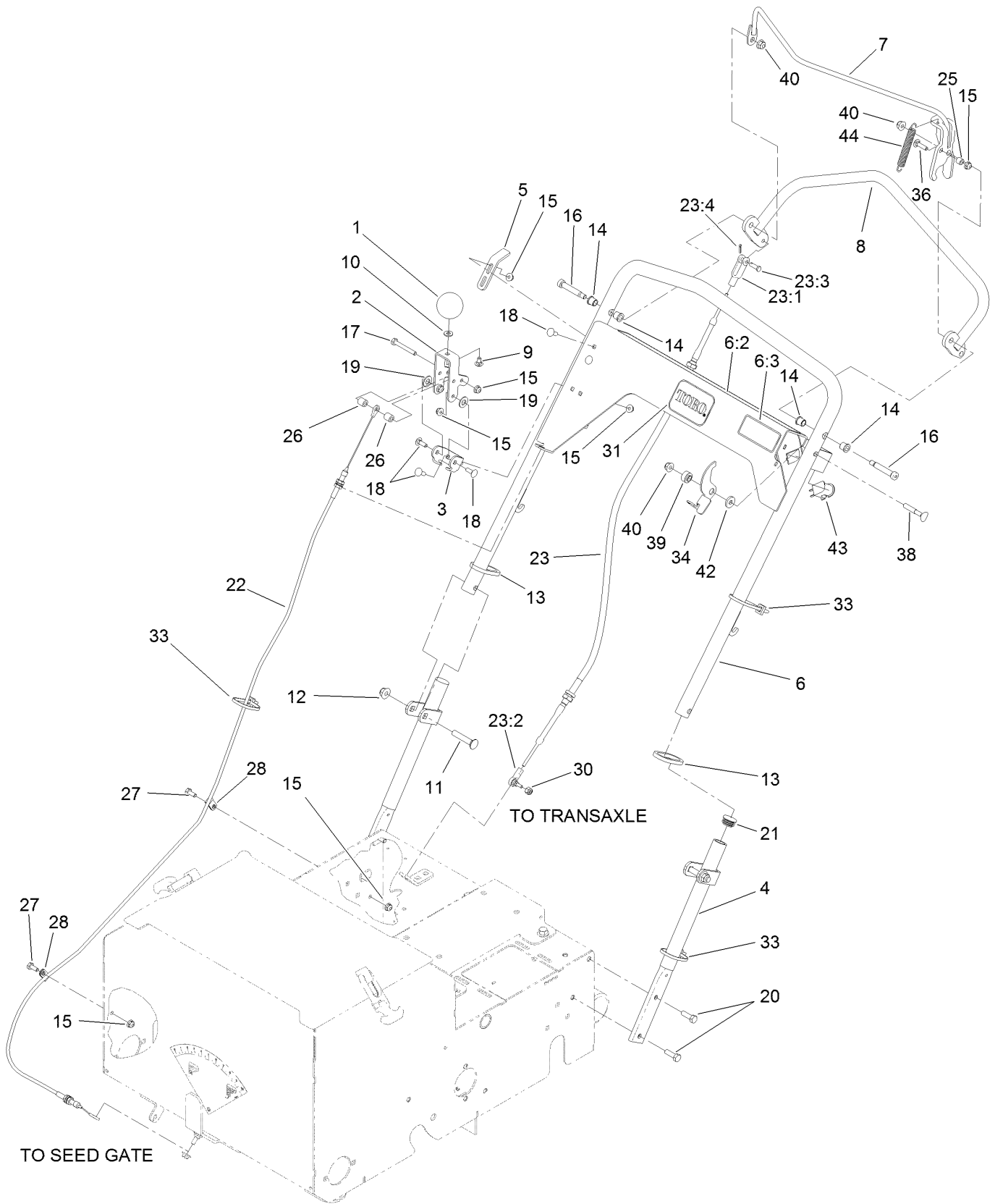

Handle Assembly (continued)

<i>Ref.</i>	<i>Part Number</i>	<i>Qty.</i>	<i>Description</i>	<i>Ref.</i>	<i>Part Number</i>	<i>Qty.</i>	<i>Description</i>
1	121-1877	1	Knob-Rate, Flow	21	121-4870	2	Plug
2	121-1878	1	Lever-Adjust, Flow	22	126-0042	1	Cable-Flow, Seed
3	121-1879	1	Bracket-Adjust, Flow	23	116-8252	1	Cable-Push Pull
4	121-1893-03	2	Handle-Lower	23:1	121-2000	1	Clevis
5	121-1928	1	Bracket-Adjust, Drive	23:2	117-9720	1	Ball Joint
6	116-9735	1	Handle	23:3	283-67	1	Pin-Clevis
6:2	116-8648	1	Decal-Control Panel, Seeder	23:4	3272-5	1	Pin-Cotter
6:3	116-8536	1	Decal-Safety Latch	25	66-8010	1	Spacer
7	126-0509-03	1	Bail-Clutch	26	22-7810	2	Spacer
8	121-1948-03	1	Handle-Drive	27	321-3	2	Screw-HH
9	3229-10	1	Screw-CARR ●	28	2412-149	2	Clamp-Hose
10	3256-22	1	Washer-Flat	30	3296-3	1	Nut-Lock
11	3231-6	2	Screw-CARR	31	70-2200	1	Decal
12	104-8301	2	Nut-Flange, NI	33	3290-378	3	Tie-Cable
13	121-6202	2	Ring-Handle Lock	34	126-0205	1	Latch-Bail
14	103-9928	4	Bearing	36	3229-2	1	Screw-CARR
15	104-7201	10	Nut-Flange, NI	38	112-8876	1	Screw-Handle
16	126-0277	2	Screw-Shoulder	39	116-2690	1	Bushing-Stepped
17	321-11	1	Screw-HH	40	104-8300	3	Nut-Flange, NI
18	3229-1	6	Bolt-CARR	42	88-7200	1	Washer-Flat
19	48-9220	2	Washer	43	82-2190	1	Switch-Bail
20	322-5	4	Screw-HH	44	95-3805	1	Spring

● Use Pro-Lock, Nut Type (P/N 1-840022, .5ml tube) on threads.

Cutting Wheel Assembly

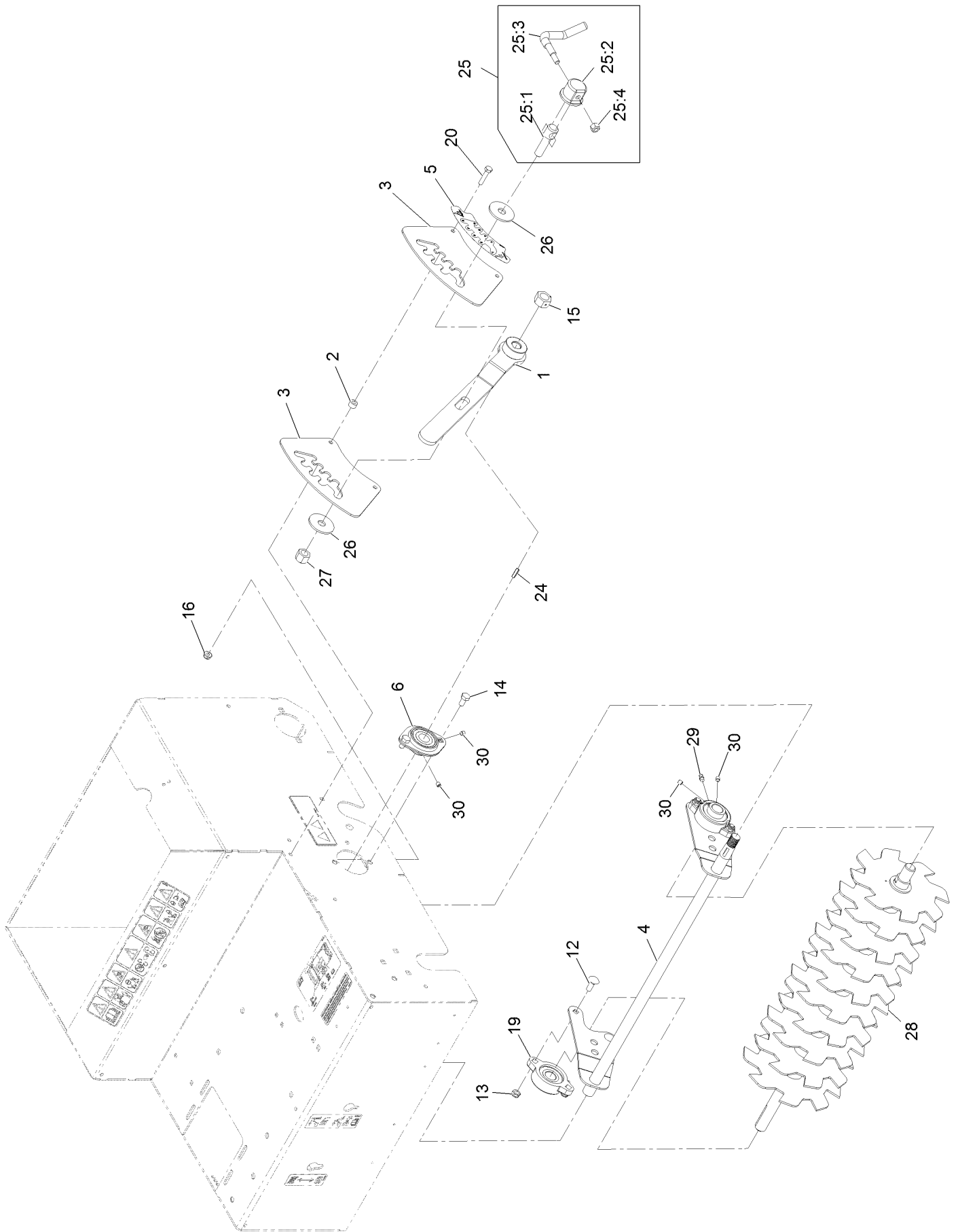

Cutting Wheel Assembly (continued)

<i>Ref.</i>	<i>Part Number</i>	<i>Qty.</i>	<i>Description</i>	<i>Ref.</i>	<i>Part Number</i>	<i>Qty.</i>	<i>Description</i>
1	116-9932-03	1	Handle-Height	20	321-8	2	Screw-HH
2	98-4799	2	Spacer	24	3257-5	1	Key-Woodruff
3	116-9928	2	Plate-Height	25	107-1664	1	Lever ASM
4	126-0010-03	1	Pivot-Height	25:1	106-3239	1	Screw-Lock
5	126-2446	1	Decal-Cut Depth, Slicer/Seeder	25:2	107-1644	1	Cap-Lock
6	121-1961	2	Bearing	25:3	106-3241	1	Lever-Lock
12	3230-16	4	Screw-CARR	25:4	3296-29	1	Nut-Lock, NI
13	3296-47	4	Nut-Lock, NI	26	86-1990	2	Washer-Thrust
14	322-2	4	Screw-HH	27	3296-23	1	Nut-Lock, NI
15	603164	1	Nut-Blade	28	126-0034	1	Slicer Shaft ASM
16	104-7201	2	Nut-Flange, NI	29	302-19	2	Fitting-Grease ●
19	116-9992	2	Bearing-Flange	30	3245-35	8	Screw-Set, HSH ●

● Use Pro-Lock, Nut Type (P/N 1-840022, .5ml tube) on threads.

Shaft Assembly No. 126-0034

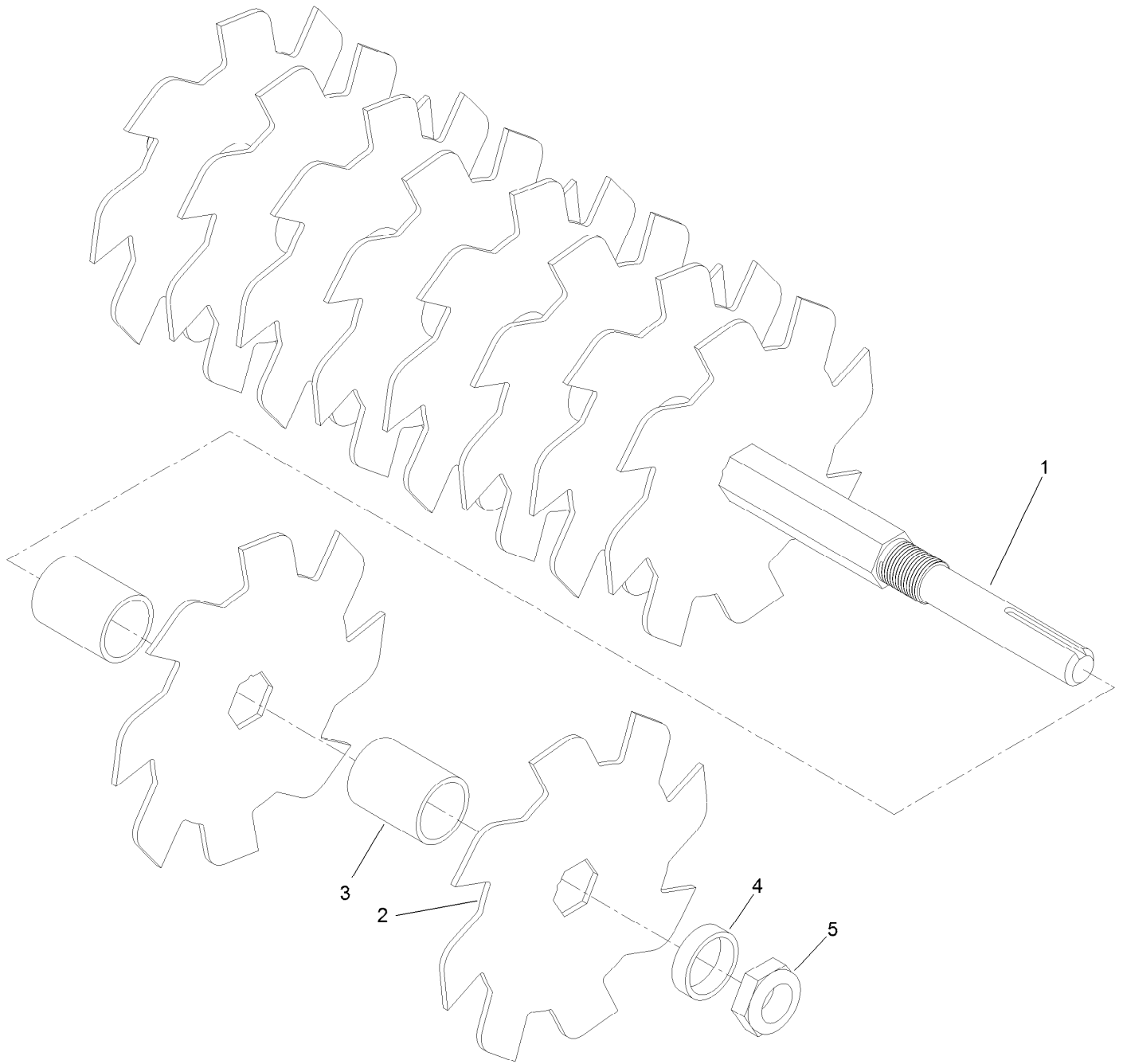

Shaft Assembly No. 126-0034 (continued)

<i>Ref.</i>	<i>Part Number</i>	<i>Qty.</i>	<i>Description</i>
1	126-0009	1	Shaft-Slicer
2	121-1931	10	Blade-Cutting, Seeder
3	126-0041	9	Spacer-Blade

<i>Ref.</i>	<i>Part Number</i>	<i>Qty.</i>	<i>Description</i>
4	126-0033	1	Spacer
5	3296-60	1	Nut-Lock, NI

Seed Gate Assembly

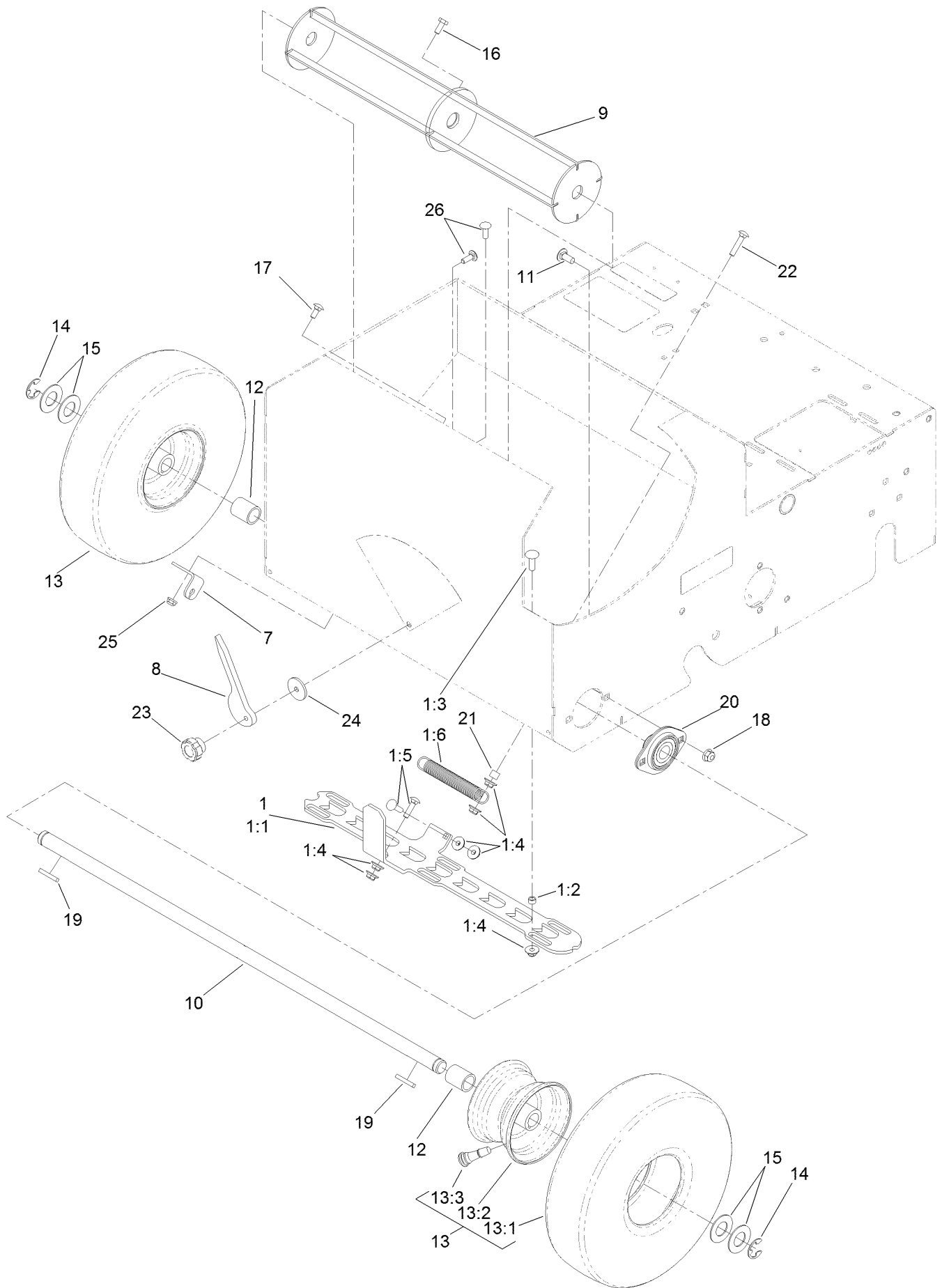

Seed Gate Assembly (continued)

<i>Ref.</i>	<i>Part Number</i>	<i>Qty.</i>	<i>Description</i>	<i>Ref.</i>	<i>Part Number</i>	<i>Qty.</i>	<i>Description</i>
1	126-0815	1	Seed Gate Kit	13:2	126-4263	1	Rim-Gray
1:1	126-0415	1	Gate-Seed	13:3	5108	1	Valve
1:2	126-0416	6	Spacer	14	32151-48	2	E-Ring
1:3	1-807512	6	Bolt-CARR	15	3256-39	4	Washer-Flat
1:4	114-3778	12	Nut-Lock, NI	16	321-3	1	Screw-HH ●
1:5	3229-2	3	Screw-CARR	17	3229-11	2	Screw-CARR
1:6	121-2016	2	Spring-Extension	18	104-8300	4	Nut-Flange, NI
7	121-1907	1	Bracket-Seed Flow	19	92-0049	2	Key-Square
8	121-1912	1	Gauge-Seed Flow	20	121-1961	2	Bearing
9	125-3782-03	1	Mixer	21	66-8010	2	Spacer
10	121-1929	1	Axle-Front ■	22	3229-3	2	Screw-CARR
11	3230-23	4	Screw-CARR	23	233-67	1	Knob-Chute
12	105-3838	2	Spacer	24	103995	1	Washer
13	126-4264	2	Wheel And Tire ASM	25	104-7201	2	Nut-Flange, NI
13:1	121-6081	1	Tire	26	1-807512	1	Bolt-CARR

- Use Pro-Lock, Nut Type (P/N 1-840022, .5ml tube) on threads.
- Apply anti-seize compound to axle ends before installing tires.

Belt Drive Assembly

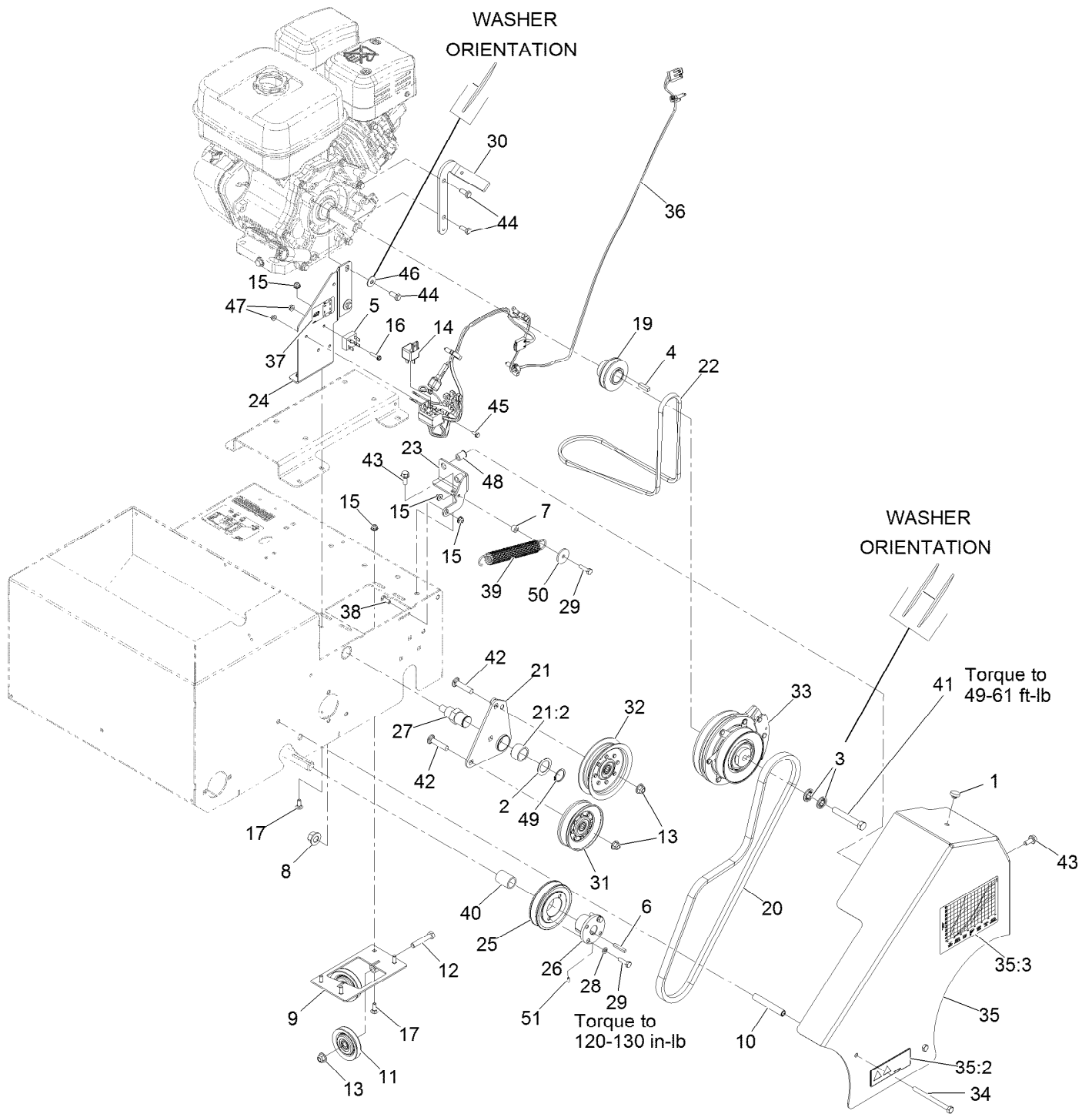

Belt Drive Assembly (continued)

<i>Ref.</i>	<i>Part Number</i>	<i>Qty.</i>	<i>Description</i>	<i>Ref.</i>	<i>Part Number</i>	<i>Qty.</i>	<i>Description</i>
1	1-513658	1	Bumper	28	3253-3	2	Washer-Lock
2	1-543436	1	Washer-Spacer	29	321-6	3	Screw-HH
3	1-603610	2	Washer-Spring	30	116-9551	1	Stop-Clutch
4	1-807259	1	Key	31	116-9623	1	Pulley-Idler V
5	37-7600	1	Rectifier-Bridge	32	116-9728	1	Pulley-Idler Flat (4.06-Inch)
6	92-0049	1	Key-Square	33	116-9852	1	Clutch-Electric
7	98-4799	1	Spacer	34	322-19	2	Screw-HH
8	99-5107	1	Nut-Lock	35	116-9925	1	Belt Guard ASM
9	126-0418-03	1	Pulley-Tension	35:2	93-7321	1	Decal-Danger
10	104-0502	2	Spacer-Kickstand, Long	35:3	116-8537	1	Decal-Seed Graph
11	121-1965	2	Pulley-Idler	36	116-9926	1	Harness-Slicer/Seeder ■
12	323-10	2	Screw-HH	37	116-9985	1	Decal-Bridge Rectifier
13	104-8301	4	Nut-Flange, NI	38	321-3	1	Screw-HH
14	105-4145	1	Relay	39	126-0091	1	Spring-Extension
15	104-7201	8	Nut-Flange, NI	40	126-0108	1	Spacer
16	106-9169	1	Screw-HWH	41	3212-12	1	Screw-HH ●
17	3229-1	6	Bolt-CARR	42	3231-29	2	Screw-CARR
19	116-9471	1	Pulley-Mule Drive	43	3234-47	3	Screw-HHF
20	116-9518	1	Belt-Seeder, Clutch	44	3235-6	4	Screw-HH
21	116-9519	1	Idler Arm ASM	45	3290-321	1	Screw-HWH
21:2	116-9538	1	Bushing	46	3290-456	2	Washer-Belleville
22	116-9532	1	Belt-Mule Drive	47	32128-17	2	Nut-Lock, Flange
23	116-9533-01	1	Bracket-Spring	48	32148-7	2	Nut-Insert
24	116-9534-01	1	Support-Engine	49	32151-29	1	Ring-Retaining
25	121-2019	1	Sheave-Taper Lock	50	103995	1	Washer
26	121-2022	1	Bushing-Taper Lock	51	126-0284	1	Screw-Set, Hs
27	116-9539	1	Pivot-Idler				

● Use Pro-Lock, Nut Type (P/N 1-840022, .5ml tube) on threads.

■ Use dielectric grease on all unsealed connectors and terminals only. Do not apply in sealed connectors.

Transmission Assembly

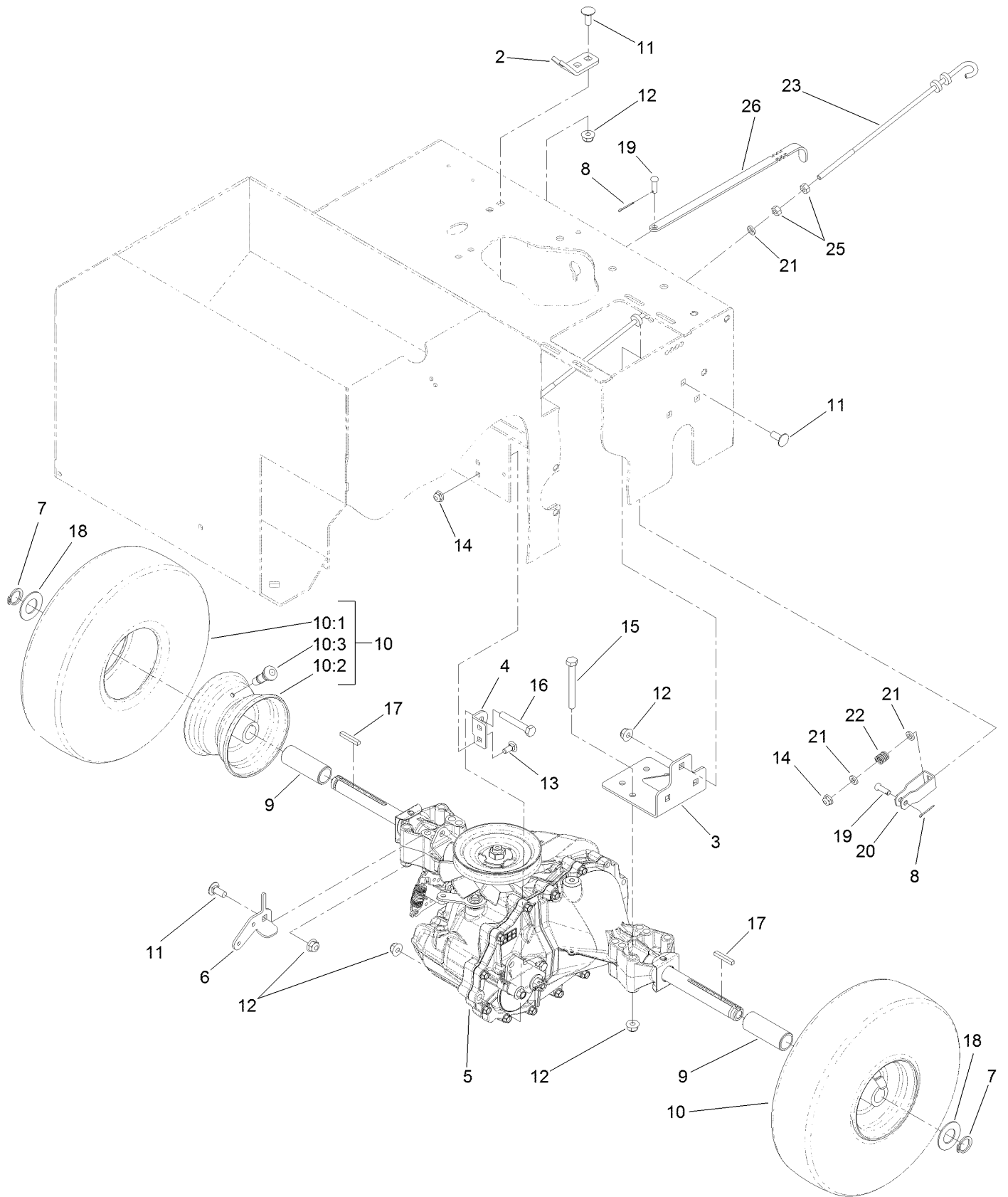

Transmission Assembly (continued)

<i>Ref.</i>	<i>Part Number</i>	<i>Qty.</i>	<i>Description</i>	<i>Ref.</i>	<i>Part Number</i>	<i>Qty.</i>	<i>Description</i>
2	121-1897	1	Bracket-Cable	13	3229-11	2	Screw-CARR
3	121-1901-03	2	Bracket-Axle	14	104-7201	3	Nut-Flange, NI
4	121-1904	1	Bracket-Transaxle, Torque	15	322-13	8	Screw-HH
5	121-1908	1	Transaxle ASM ●	16	322-10	1	Screw-HH
6	121-1909	1	Bracket-Transaxle	17	92-0049	2	Key-Square
7	32120-93	2	Ring-Retaining	18	67-9410	2	Washer
8	3272-4	2	Pin-Cotter	19	1-808265	2	Pin-Clevis
9	121-1988	2	Spacer	20	39-3080	1	Clevis
10	126-4264	2	Wheel And Tire ASM	21	55-9620	3	Spacer-Plate, Pivot
10:1	121-6081	1	Tire	22	63-4220	1	Spring-Compression
10:2	126-4263	1	Rim-Gray	23	121-2018	1	Rod-Brake
10:3	5108	1	Valve	25	3217-5	2	Nut-Hex
11	3230-23	9	Screw-CARR	26	121-2039	1	Lever-Bypass
12	104-8300	18	Nut-Flange, NI				

● Apply anti-seize compound to axle ends before installing tires.



Count on it.