



HS - SERIES
SEMI-VORTEX - WASTEWATER PUMP - WITH AGITATOR

SPECIFICATIONS

FEATURES

1. Semi-vortex urethane rubber impeller with agitator suspends solids and allows for pumping of sand and stringy material.
2. Highly efficient, continuous duty air-filled, copper wound motor with class E insulation minimizes the cost of operation.
3. Built in thermal protection prevents motor failure due to overloading, accidental run-dry and single phasing in three phase units.
4. Double inside mechanical seals with silicon carbide faces running in an oil filled chamber provide for one the most durable seal designs available.
5. Double shielded, permanently lubricated, high temperature C3 ball bearings rated for a B-10 life of 60,000 hours

provide for extended operational life.

HSZ : Provides automatic operation by utilizing a simple float switch.

HSD : Compact single phase pump fit for use in slurry dewatering in foundation works.

APPLICATIONS

1. Residential, commercial, industrial wastewater and site drainage.
2. Decorative waterfalls and fountains.
3. Raw water supply from lakes or rivers.
4. Sediment removal from small sumps or basins.



SPECIFICATIONS

- Discharge Size
- Horsepower Range
- Performance Range Capacity Head
- Maximum water temperature
- Materials of Construction
 - Casing
 - Impeller
 - Shaft
 - Motor Frame
 - Fasteners
- Mechanical Seal
 - Elastomers
- Impeller Type
- Solids Handling Capability
- Bearings
- Motor Nomenclature
 - Type, Speed, Hz.
 - Voltage, Phase
 - Insulation
- Accessories
- Operational Mode

STANDARD

- 2 - 3 "NPT (50 - 80 mm)
- 1/2 - 1HP. (0.40 - 0.75kW)
- 13.2 - 61.0 GPM. (0.05 - 0.23 m³/min)
- 13.1 Ft. - 62.0 Ft. (4.0 - 18.9 m)
- 104° F. (40° C.)
- Cast Iron , Ductile Cast Iron(HSD)
- Urethane Rubber , High Chrome Cast Iron(HSD)
- 403 Stainless Steel
- Aluminum alloy
- 304 Stainless Steel
- Silicon Carbide
- NBR (Nitrile Butadiene Rubber)
- Semi-vortex, solids handling
- 0.276 - 0.393" (7.0 - 10.0mm)
- Prelubricated, Double Shielded
- Air Filled, 3600 RPM, 60 Hz.
- 115 / 230V., 1 Phase
- Class E
- Submersible Power Cable
- 20 - 32' (6.2 - 10m)
- Manual , Automatic(HSZ)

OPTIONS

- Length as Required,
- TS-301 Float Switch



HS - SERIES
SEMI-VORTEX - WASTEWATER PUMP

DIMENSIONS

HS2.4S-62

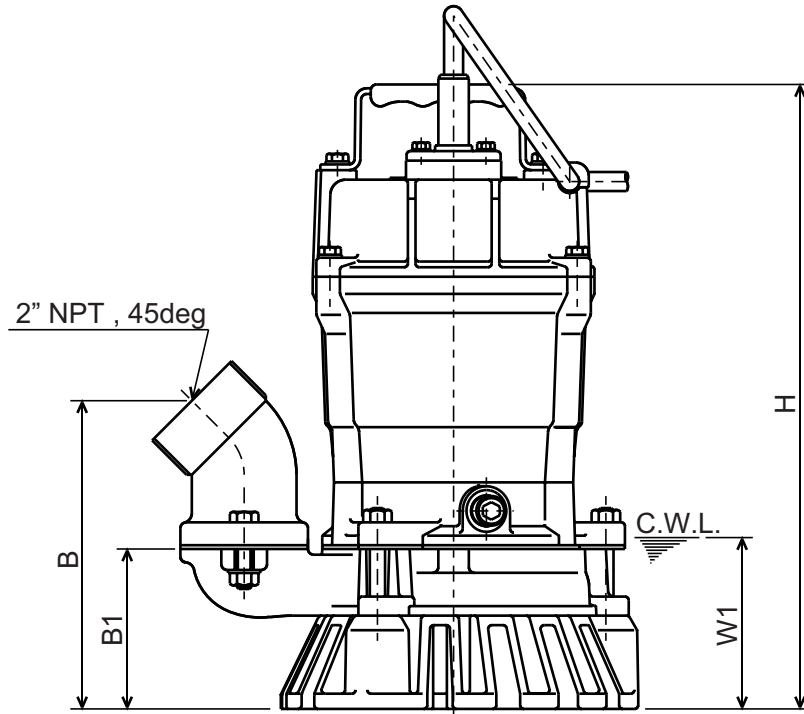
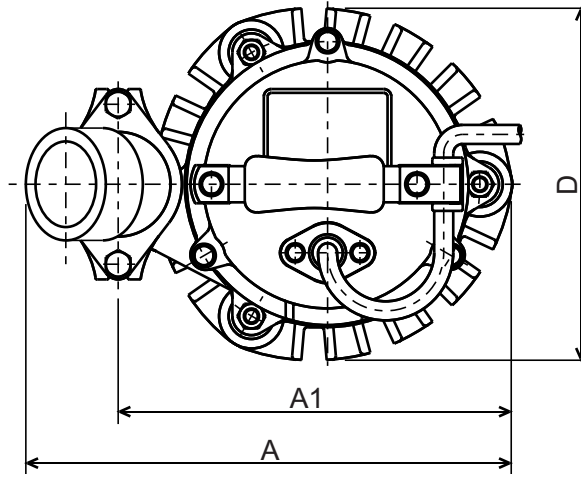

C.W.L. : Continuous running Water Level

DIMENSIONS:USCS (Inch)

Model	HP	NOM. SIZE	Pump & Motor						C.W.L.	Wt. (lbs.)
			A	A1	B	B1	D	H	W1	
HS2.4S-62	1/2	2"	10 1/16	8 1/8	6 3/8	3 5/16	7 5/16	12 15/16	3 1/2	25

DIMENSIONS:METRIC (mm)

Model	kW	NOM. SIZE	Pump & Motor						C.W.L.	Wt. (kg)
			A	A1	B	B1	D	H	W1	
HS2.4S-62	0.40	50	255	207	162	84	185	328	90	11.3