

FROST *Fight*er

INDIRECT FIRED SPACE HEATERS



MODEL IDH200QR OIL
MODEL IDH200QR LP/NG

Installation - Operation/Maintenance Instructions and Parts List

READ INSTRUCTIONS PRIOR TO STARTING HEATERS



FROST FIGHTER INC.
100-1500 NOTRE DAME AVE
WINNIPEG, MANITOBA
CANADA R3E 0P9
TEL : (204) 775-8252
FAX: (204) 783-6794

WWW.FROST-FIGHTER.COM
TOLL FREE 1-888-792-0374

FROSTFIGHTER WARRANTY

Frost Fighter Inc. warrants the Frostfighter heater to be free from defects in workmanship and materials for a period of twelve (12) months from date of initial service not to exceed fifteen (15) months from date of shipment.

If during the warranty period, the heat exchanger fails under normal use and service due to a defect in material or workmanship said heat exchanger will be repaired or replaced free of charge F.O.B. the Winnipeg Factory..

All mechanical and electrical components are covered by a one (1) year limited warranty. Normal maintenance items are excluded under the warranty. The warranty does **NOT** include any freight, labor or sales taxes incurred by the purchaser and is subject to the following conditions:

1. The heater shall be operated in accordance with the manufacturer's operating and maintenance manual.
2. The heater shall be subject to normal use in service and shall not have been misused, neglected, altered or otherwise damaged.
3. The unit shall be operated within the rated capacities and with the prescribed fuel.
4. The unit has not been allowed to exceed its proper temperature limits due to control malfunction or inadequate air circulation.
5. There is no evidence that the unit has been subject to tampering or deliberate destruction.
6. The heat exchanger shows no signs of an implosion or explosion.

No representative of Frost Fighter Inc., nor any of its distributors or dealers, is authorized to assume for Frost Fighter Inc. any other obligations or liability in connection with this product, nor alter the terms of the warranty in any way. This warranty is limited to the express provisions contained herein and does not extend to liability for labor costs incurred in replacing defective parts.

Parts can be obtained from Frost Fighter Inc, Winnipeg, Manitoba on the basis that credit will be issued if the defective parts returned qualify for replacement pursuant to the terms and conditions of this warranty. Authorization to return any alleged defective parts must be first obtained from the factory prior to transporting the part. A R.G.A.# must be provided from an Frost Fighter Inc representative. The transportation charges for the alleged defective part must be prepaid by the owner. Frost Fighter Inc. will not accept charges for parts purchased unless the conditions of this warranty have been satisfied and prior authorization to purchase the parts has been received from the factory.



100-1500 NOTRE DAME WINNIPEG, MANITOBA
R3E 0P9, (204) 775-8252

SPECIFICATIONS

MODEL	MAXIMUM INPUT	NOZZLE SIZE	PUMP PRESSURE	FUEL TANK CAPACITY	ELECT. SUPPLY	HEATED AIR (CFM)	APPROVAL AGENCY	DRY WEIGHT (APPROX)
IDH200QR OIL	170,000 BTU/HR	1.0 X 60'B	???	18 USGAL 72 LITERS	115v 15 A	1500		209 LBS 95 KG

MODEL	MAXIMUM INPUT	MAX INLET PRESSURE	MANIFOLD PRESSURE	MINIMUM INLET PRESSURE	ELECT. SUPPLY REQUIRED	HEATED AIR (CFM)	APPROVAL AGENCY	DRY WEIGHT
IDH200QR LP/NG	170,000 BTU/HR	14 IN. 1/2 LBS	3.5" NG 1.8" LP	18 USGAL 72 LITERS	115V 15A	1500		209 LBS 95 KG

PLEASE REFER TO PAGE 7 IF KEROSENE IS NOT BEING USED.

Flue size-6" on all units

NOTE: -These heaters are intended for use primarily as temporary heating of buildings under construction, alteration or repair

MAXIMUM ALLOWABLE DUCT LENGTHS (IDH200 OIL & LP/NG)

- 100 feet 12" outlet ducting w/ 0 feet 12" inlet ducting
- 75 feet 12" outlet ducting w/ 25 feet 12" inlet ducting
- 50 feet 12" outlet ducting w/ 50 feet 12" inlet ducting

Dimensions of IDF350-II and of the IDF500 Heaters

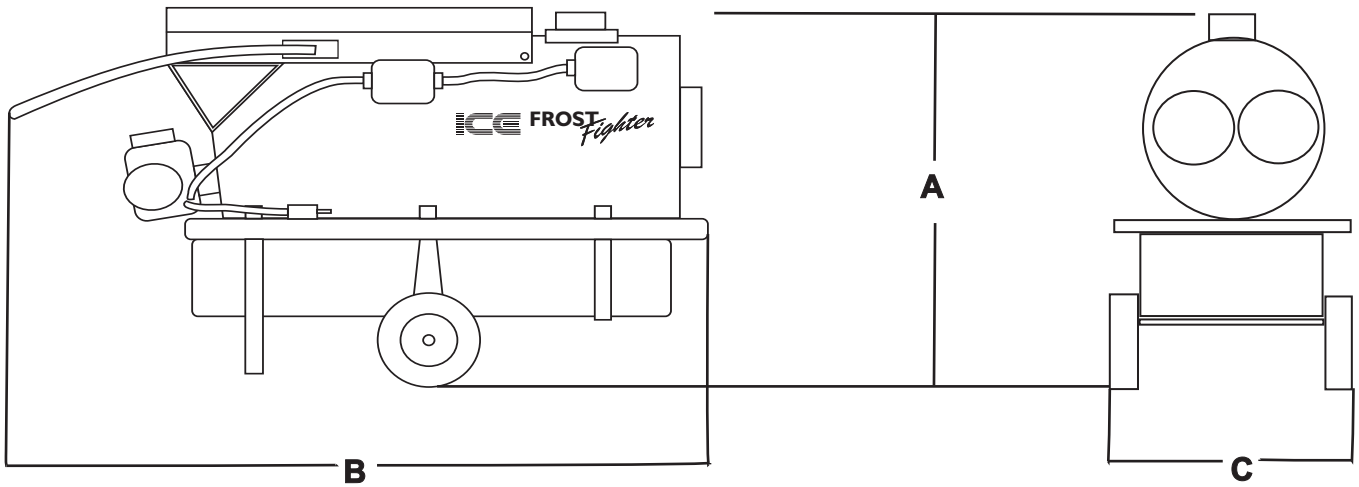

Heater Only					With Packaging			
MODEL	A	B	C	WEIGHT (LBS)	L	W	H	WEIGHT (LBS)
IDF350	51"	76 1/2"	27"	510	83"	38"	52 1/2"	562
IDF500	51"	76 1/2"	27"	510	83"	38"	52 1/2"	562

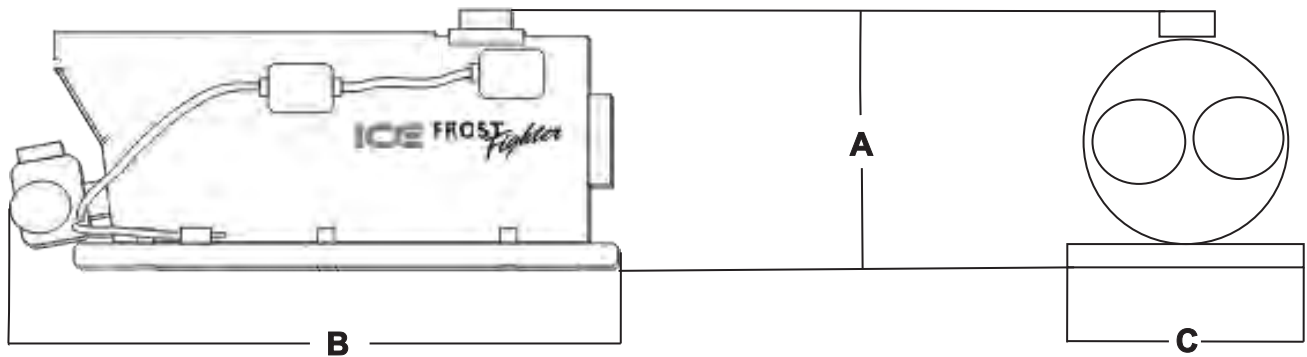

Heater Only					With Packaging			
MODEL	A	B	C	WEIGHT (LBS)	L	W	H	WEIGHT (LBS)
IDF350	29 1/2"	65 1/2"	25"	325	70 1/2"	32"	35 1/4"	375
IDF500	29 1/2"	65 1/2"	25"	325	70 1/2"	32"	35 1/4"	375

**INSTALLATION- OPERATION
MAINTENANCE INSTRUCTIONS FOR LP/NG**

READ INSTRUCTIONS PRIOR TO OPERATING HEATER

GENERAL HAZARD WARNING

FAILURE TO COMPLY WITH PRECAUTIONS AND INSTRUCTIONS PROVIDED WITH THIS HEATER CAN RESULT IN DEATH, SERIOUS BODILY INJURY AND PROPERTY LOSS OR DAMAGE FROM HAZARDS OF FIRE, EXPLOSION, BURN, ASPHYXIATION, CARBON MONOXIDE POISONING, AND/OR ELECTRICAL SHOCK.

ONLY PERSONS WHO CAN UNDERSTAND AND FOLLOW THE INSTRUCTIONS SHOULD USE OR SERVICE THIS HEATING UNIT.

IF YOU REQUIRE ASSISTANCE OR HEATER INFORMATION SUCH AS AN INSTRUCTION MANUAL, LABELS, ETC., CONTACT THE MANUFACTURER.

WARNING

FIRE, BURN INHALATION, AND EXPLOSION HAZARD. KEEP SOLID COMBUSTIBLES, SUCH AS BUILDING MATERIAL, PAPER AND/OR CARDBOARD A SAFE DISTANCE AWAY FROM THE HEATER AS RECOMMENDED BY THE INSTRUCTIONS. NEVER USE THE HEATER IN SPACES WHICH MAY CONTAIN VOLATILE OR AIRBORNE COMBUSTIBLES, OR PRODUCTS SUCH AS GASOLINE, SOLVENTS, PAINT THINNER, ACETONE, DUST PARTICLES AND/OR UNKNOWN CHEMICALS.

WARNING

THIS PRODUCT IS NOT INTENDED FOR HOME OR RECREATIONAL VEHICLE USE.

FOR YOUR SAFETY

DO NOT USE THIS HEATER IN A SPACE WHERE GASOLINE OR OTHER LIQUIDS HAVING FLAMMABLE VAPOURS ARE STORED OR USED.

GENERAL NOTES:

NATURAL/PROPANE GAS CODE: B149.1

ALL GAS INSPECTION AUTHORITIES IN CANADA REQUIRE THAT THE INSTALLATION AND MAINTENANCE OF HEATER AND ACCESSORIES SHALL BE ACCOMPLISHED BY A QUALIFIED GAS FITTER.

GENERAL NOTES:

1. The heater is designed and approved for use as a construction heater under ANSI Z83.7 with the applicable requirements of UL 795 and under CGA 2.14 with applicable requirements of CAN/CSA 3.2. The intended use is for the temporary heating of building or structures under construction, alteration or repair.
2. ICE cannot anticipate every use, which may be made of our heaters. **CHECK WITH YOUR LOCAL FIRE AND SAFETY AUTHORITY IF YOU HAVE QUESTIONS ABOUT SAFE APPLICATIONS.**
3. Other standards govern the use of fuel gases and heat producing products in specific applications. Your local authority can advise you about this issue.
4. Please retain this instruction manual for future reference.
5. The primary application of this heater is for temporary heating of construction sites and/or applications of this type.

ELECTRICAL NOTES:

1. All electrical connections and grounding shall be in compliance with the National Electrical Code and/or the Canadian Electrical Code (CSA Standard C22.1-98).
2. **WARNING:** Electrical grounding instructions... This appliance is equipped with a three prong(grounding) plug for your added protection against electrical shock hazard and should be plugged directly into a properly grounded three-prong receptacle.

ADDITIONAL INSTRUCTIONS FOR PROPANE GAS:

1. Reference the Storage and Handling of Liquefied Petroleum Gas, ANSI/NFPA 58 and/or the National Standards of Canada CAN/CGA B149.2 installation codes for propane gas.
2. The heater must be located more than six (6) feet (1.83 meters) away from the propane source or propane tank.
3. When the heater is not in use insure to shut off the gas supply from the propane source or propane tank.
4. Disconnect the heater from the propane source or propane tank when storing the heater indoors.
5. The heater must not discharge toward any propane gas container within 20 feet (6 M).

INSTALLATION INSTRUCTIONS:

6. The National Fuel Code, ANSI 223.1/NFPA 54 and/or National Standards of Canada CAN/CGA B149.1 installation codes must be followed as well as the recommendations of local authorities having jurisdiction.
7. Inspect the heater before each use and have it annually inspected by a qualified agency.
8. Inspect the hose assembly for wear, cuts, etc. and replace if necessary.
9. When firing the unit in an enclosed area, three square feet (0.278 square meters), must be provided to allow free entry of the air required for operation.
10. Do not operate the unit in partly ventilated areas without a flue pipe connected to the unit.
11. Do not operate the unit in close proximity to combustible surfaces and materials.
12. The cylinder supply system must be arranged to provide for vapor withdrawal from the operating cylinder.
13. Propane tank size should be a minimum 100 lbs. (90 liters)

INSTALLATION INSTRUCTIONS FOR OIL

1. The recommendations of local authorities having jurisdiction must be followed. For recommended Installation practices refer to C.S.A. Standard B139 (CANADA) or NFPA 54 (US)
2. When firing the unit in an enclosed area 3 square feet must be provided to allow the free entry of the air required for operation.
3. For electrical supply, use 3 wire receptacle with "U" ground.
4. Do not operate the unit in partly ventilated areas without a flue pipe or in close proximity to combustible surfaces or materials.

NOTE: Installation clearances are as follows:

Top - 3 inches
Sides - 6 inches
Burner End - 2 feet

Discharge End - 10 feet
Vent Connector - 18 inches
Floor - Combustible

FLUE PIPE CONNECTIONS

When the heater is connected to a flue pipe the flue pipe shall terminate in a vertical section at least two feet long. Horizontal runs should have rise ratio of 1 in 10 away from the heater. The chimney should have .02" W.C. draft to ensure safe operation of the unit. Where down drafts are liable to occur a vent cap should be used. All venting Should correspond with the CSA B149 (CANADA), NFPA 54 (US) standard or local codes.

INSTALLATION CLEARANCES

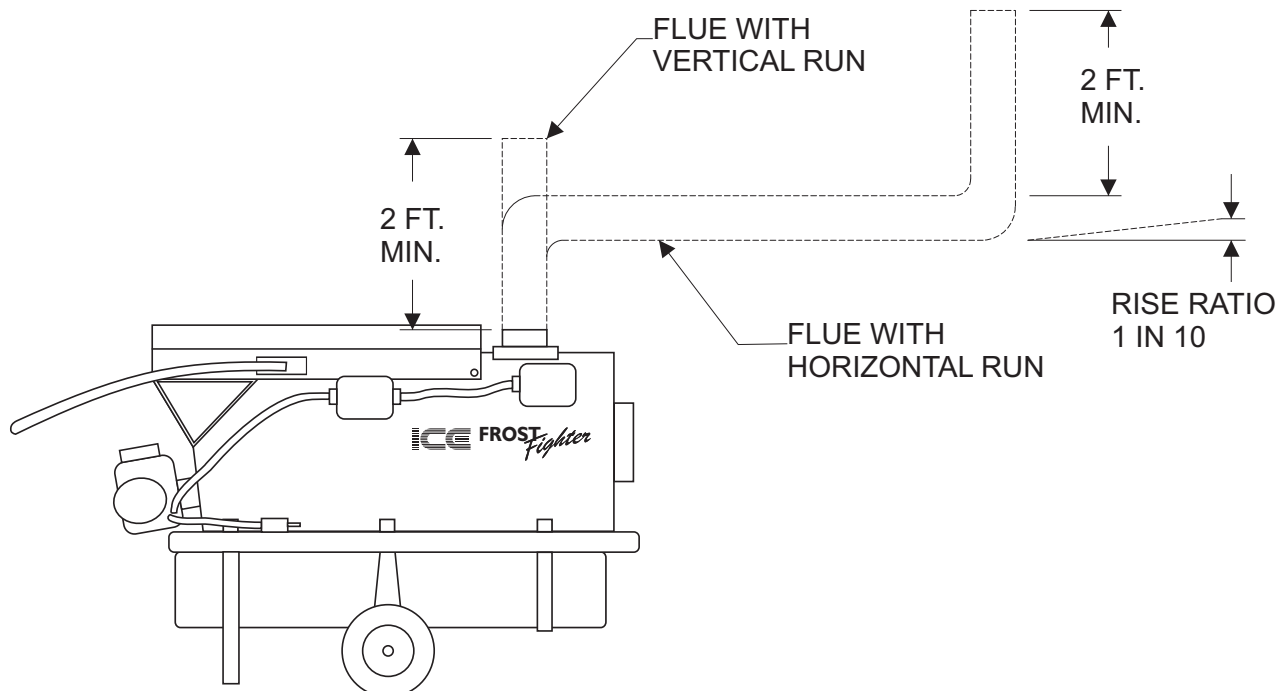

OPERATING INSTRUCTIONS

TO START HEAT WITH GENISYS OIL CONTROL

1. Ensure unit is on flat, level ground before starting, canopy and fan guards must be closed.
2. Flip switch to "OFF" position
3. Check fuel level (2-4 gallons to start)
4. Plug in supply cord to 115 volt outlet.
5. Flip switch to "MANUAL" position.
6. For thermostat operation flip switch to "THERM" position.
7. There will be a 5 second safe start check, a 15 second pre purge then the burner will fire.

IF HEATER FAILS TO START

1. Press manual reset button on burner relay.
2. Check for low voltage condition and 115 volt supply.
3. Check fuel filter, suction tubing and nozzle assembly

NOTE: If unit has been reset a number of times without ignition there will be an accumulation of oil in the combustion chamber! Do the Following:

1. Make sure unit is sitting on level ground to ensure excess oil drain out of secondary exchanger (via small drain hole located on outer shell of heat exchanger by burner end).
2. Allow unit to drain for 15-20 minutes or until all oil has drained out.
3. Upon ignition excessive amounts of smoke will be present until all excess oil has been burnt from the heat exchanger.
4. When the unit has stabilized and the burner set up to operate properly, shut off the switch. Let the fan cool down the chamber and stop.

IF UNIT STILL DOES NOT START REFER TO THE TROUBLE SHOOTING GUIDE PAGE 12

CAUTION

1. Do not start heater when excess oil has accumulated in chamber.
2. Do not fill tank while unit is operating.
3. Do not shut off by disconnecting supply cord. The heat exchanger should be properly cooled before power shutdown.
4. In no case should extension cords be smaller than 12 A.W.G. If cord is longer than 50' use 10 A.W.G. minimum.
5. Do not use gasoline, crankcase oil or heavier than No. 2 furnace oil.
6. Always maintain adequate fuel supply.

ELECTRICAL REQUIREMENTS:

15 amp circuit IDH200QR MODELS

TO STOP HEATER

Flip switch to "OFF" position. The burner motor will continue to run for 1 minute to help cool the heat exchanger and electrodes. The supply fan will continue to operate until the heat exchanger has sufficiently cooled. Do not disconnect main power until supply fan has stopped running.

WARNING!: BEFORE MOVING ANY GUARDS OR SAFETIES DISCONNECT THE MAIN POWER AS THE SUPPLY FAN WILL CYCLE AUTOMATICALLY.

IDH OIL MAINTENANCE INSTRUCTIONS

!WARNING!: Heaters should be fully serviced annually to ensure proper performance. Maintenance should be performed by trained personnel only. Incorrect maintenance may result in improper operation and serious injury.

HIGH LIMIT SWITCH

The limit switch should be checked every heating season to ensure the burner will shutdown if temperature exceeds 220° F. (This can be done by restricting the air flow through the unit. After tests are complete, remove restriction for proper operation).

FAN SWITCH

The fan switch has been selected to allow for preheating of the heat exchanger to ensure that only heated air is allowed to enter the space. Upon satisfying the need for heat, the fan switch will continue to run the supply fan until the heat exchanger has cooled sufficiently. This feature will help prolong the life of your heat exchanger.

FUEL FILTER

Replace cartridge (48164 or 48164A) once every week of normal usage or sooner, depending upon fuel quality.

BURNER

The electrode spacing must be checked and adjusted, if necessary after every nozzle change. Nozzle should be replaced annually or sooner if burner cannot be set up to operate properly. Nozzle size and type are marked on the rating plate.

ELECTRICAL

Ensure all conduit (BX) connectors are tight. Check inside connections in control box to ensure good connections. Check marrettes.

FAN

Check for dust or dirt build up on blades. Check for tightness of the set screw. Run heater to check for fan vibration. Replace fan blade if vibration is noticeable.

MOTORS

No lubrication is necessary since the bearings are the sealed type. Clean motor of existing dust or dirt.

FUEL SYSTEM

Periodically remove fuel tank drain plug and clean tank. Do not store unit containing furnace oil for long periods. **The quality of fuel oil will affect light off at low ambient temperatures, #1 fuel oil or kerosene are recommended for temperatures below -10° C / 8° F.** (see page 7 for recommended settings if using #2 fuel oil in cold temperature)

FUEL PUMP

Check fuel pump pressure on a regular basis. This should be checked at the bleeder screw. **WITH THE CLEAN CUT PUMP ADD 10 LBS TO THIS READING TO GET THE TRUE PRESSURE.** There is a pressure loss when fuel passes through solenoid valve. Example: IDF350 pressure should be read on the guage at 135 PSI, reading at nozzle line will then be 125. Units with the Suntec A2YA7916, pressure reading can be checked at the guage port. This will provide a true reading.

HEAT EXCHANGE

If a smokey condition continues even after adjusting the air band assembly, the heat exchanger should be thoroughly cleaned as per next page.

CLEANING PROCEDURE

1. Remove front cap. (48205, 48205A or 20205)
2. Remove cover panel (jacket to front). (48119 or 20119)
3. Remove fan thermostat cover on outer jacket (the one nearest the burner). (48112A)
Loosen thermostat and remove from the jacket. Remove high limit thermostat cover.(48112). Remove the two screws that are on jacket, at the 3'o'clock & 9 o'clock position 8 inches from front of unit.
4. Slide heat exchanger out of jacket and place front face down on floor.
5. Access for combustion chamber and heat exchanger cleaning is obtained through the burner head opening and by removing the heat exchanger cap ring(s) (48115 or 50115).
6. To reassemble, reverse procedure. If you need assistance, please contact the factory.

Close canopy and ensure fan guards are in proper position before trying to restart the unit..

COMBUSTION AIR ADJUSTMENTS

****For proper combustion air adjustment a calibrated gas analyzer and smoke tester should be used to ensure complete combustion. Air adjustment should be made at the correct input and be adjusted to achieve 10% CO2. For optimum combustion efficiency the combustion air control should be set to provide no more than a No. 1 smoke (Bacharach Scale). The Beckett burner has a calibrated air band, which will assist in adjusting the primary air for a good oil/air mixture. Adjust air band supply by loosening lock screws and moving air shutter (B48254) and if necessary the bulk air band. Begin by reducing the air until the unit begins to produce smoke. Increase air until no smoke is produced. Check for excessive heat build up in the heat exchanger. Insufficient air will cause flame impingement and reduced heat exchanger life. Increase air until heat build up has been eliminated. Check for proper ignition. Once satisfied re- tighten all screws and locking mechanisms.

This adjustment is to be carried out while the unit is operating and after 5 minutes of firing. Rotating the air bands on the burner housing makes the adjustment.

AIR SETTINGS			
UNIT MODEL	SHUTTER	BAND	BURNER MODEL
IDH200QR OIL	6	0	AFG
IDH200LPNGQR	10	6	Cg4

***Note: The above settings are approximations based upon clean equipment in proper working order. Combustion air adjustments will vary with location, altitude and type of fuel used.

Due to the increased density of #2 oil at colder temperatures, kerosene fuel must be used or the oil nozzle change as follows at temperatures below 8'F/-10'C.

Model	Nozzle (USGPH)
IDH200 QR OIL	1.0 x 60' R Delevan

IDH 350QR, IDH-II350QR & IDH500QR WIRING DIAGRAM

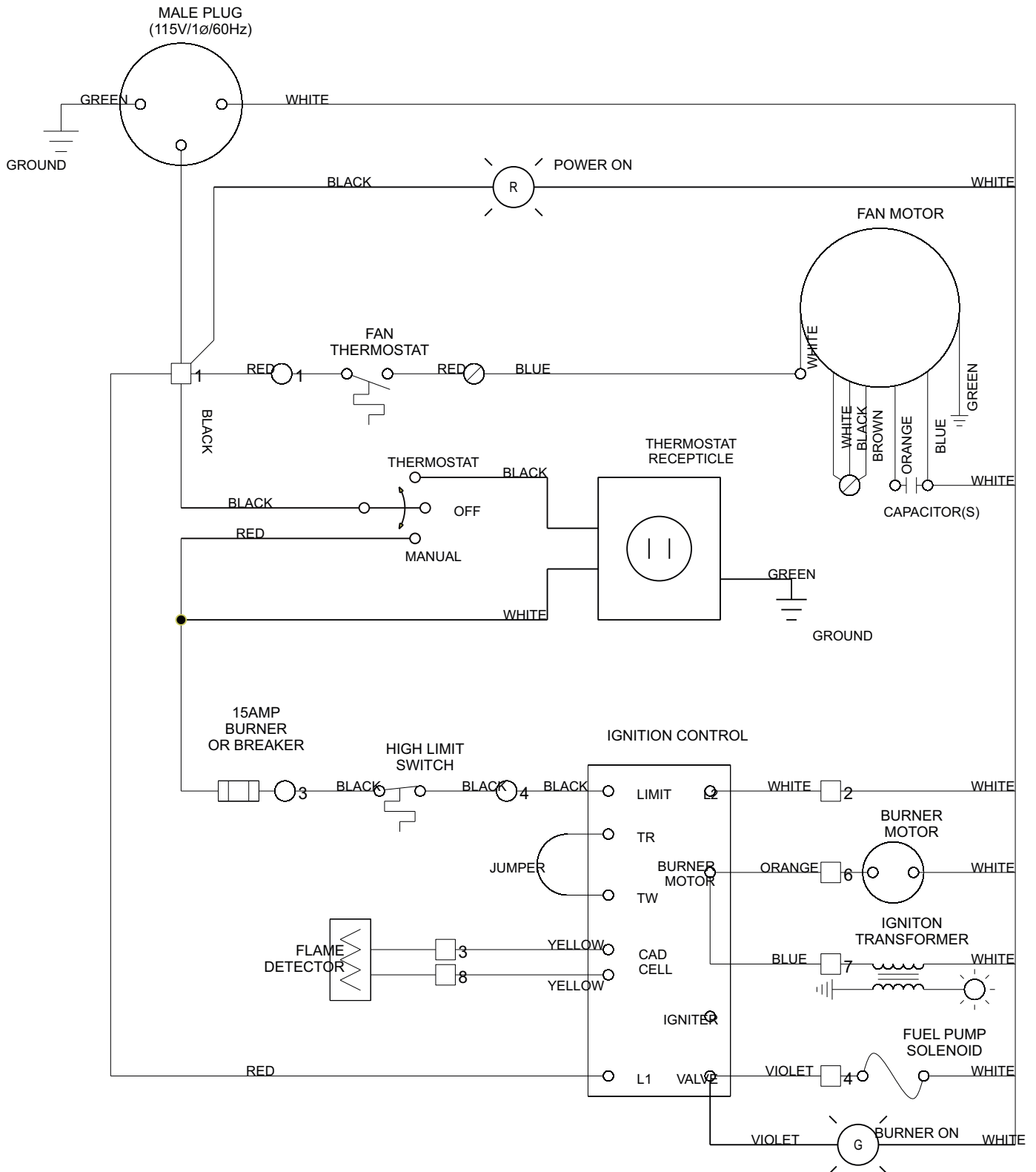

TEMPERATURE FEELER ADJUSTMENT: (Attached to fan switch)

ALWAYS MAKE SURE THAT THE TEMPERATURE FEELER IS TOUCHING THE HEAT EXCHANGER!!

The temperature feeler provides air flow over the fan switch, which regulates the cycling of the fan. The temperature feeler can be adjusted for different outside temperatures, by rotating the location of the temperature feeler holes. This will provide optimum performance of the unit in different applications, and will reduce or eliminate unnecessary fan cycling.

IF SURROUNDING AIR IS WARM (EG., -5 C or 23 F, indoor application):

TURN THE TEMPERATURE FEELER SO THAT THE HOLES ARE PARALLEL WITH THE HEAT EXCHANGER, AND ENSURE THAT NOTHING IS BLOCKING THE AIR FLOW (EG., SCREWS). BY DOING THIS THE FAN SWITCH WILL REMAIN COOL AND NOT OVERHEAT. (SEE FOLLOWING)
The fan switch is located under the high limit/fan cover which is mounted on the jacket close to front of unit. The switch can be adjusted by using a flat-headed screw driver and turning it clockwise or counter clockwise to desired temperature.

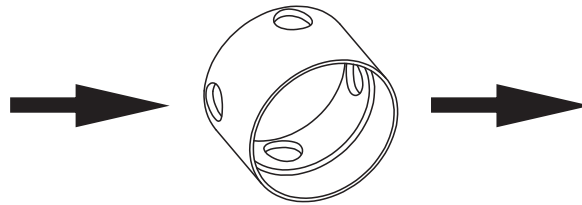

IF SURROUNDING AIR IS COLD (EG., under -5 C or 23 F)

TURN THE TEMPERATURE FEELER SO THAT THE HOLES ARE CLOSED OFF AS THE AIR GOES OVER THE HEAT EXCHANGER, THIS WILL REDUCE FAN CYCLING, UNIT SHUTDOWN, ETC. (SEE FOLLOWING)

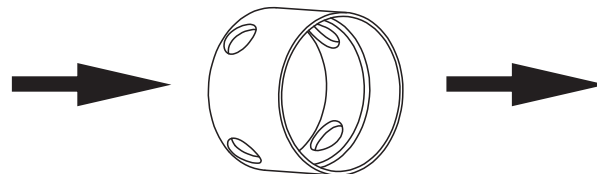

Indoor and outdoor settings of fan switch

Indoors & if surrounding air is warm i.e. -5C/23F-Fan switch should be set to 115' or higher so as to shut down unit when heat exchanger is properly cooled, also keeps fan motor from excessive running on when discharging cooler air.

Outdoor-Fan switch should be set between 100'-90'. The colder the temperature the lower the setting.

ELECTRODE SETTINGS FOR IDF350-II & IDF500 MODELS

- Check, and adjust if necessary, the critical dimensions shown in *Figure 5*. Verify that the oil tube assembly and electrodes are in good condition, with no cracks or damage.

Figure 5 - Nozzle and nozzle line assembly

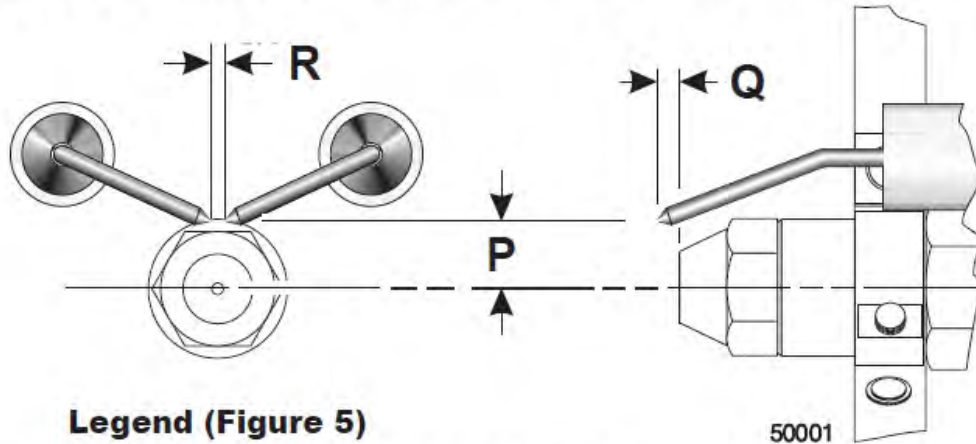

Legend (Figure 5)

- P** Nozzle centerline to electrode tip = 3/16"
- Q** Nozzle face to electrode tip = 1/4"
- R** Electrode spacing = 3/16" gap

SLIDE PLATE SETTINGS FOR IDF350-II & IDF500 MODELS

Figure 7 - Adjusting plate assy.

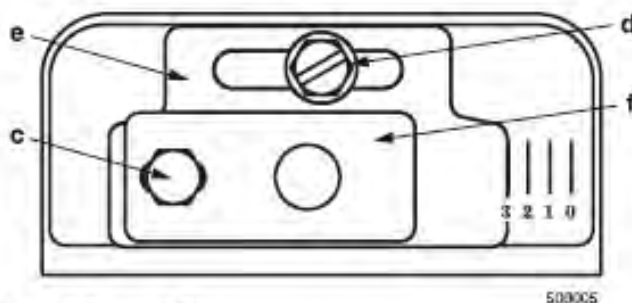

Legend (Figures 7)

- c** Bottom acorn nut
- d** Fastener
- e** Indicator adjusting plate
- f** Secondary adjusting plate

IDF350-II
IDF500

4-5
6

Check/Adjust 'Z' Dimension - V1 Heads

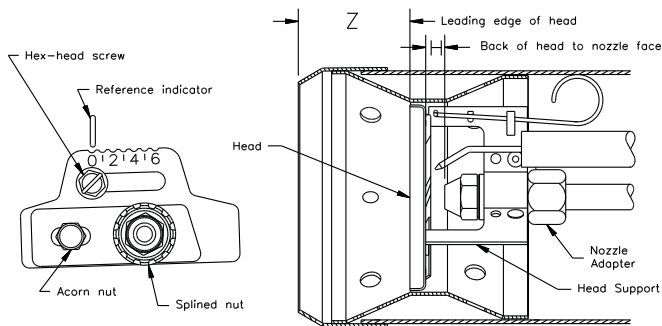

SK9460B

Figure 5. 'V1' Head

V1 heads (see Table below and Figure above for dimensions)

- See figure above. The important "Z" dimension is the distance from the leading edge of the head to the end of the air tube. This distance for V1 heads is 1-3/4". The "Z" dimension is factory set for burners shipped with the air tube installed. Even if factory set, verify that the "Z" dimension has not been changed.
- Use the following procedure to adjust the "Z" dimension, if it is not correct:
 - Turn off power to the burner.
 - Disconnect the oil connector tube from the nozzle line.
 - See figure above. Loosen the splined nut from the nozzle line.
 - Loosen the hex head screw securing the head adjusting plate to the burner housing.
 - Loosen the acorn nut. Move the head adjusting plate until the "0" lines up with the reference indicator on the housing, and retighten the hex head screw. Place the end of a ruler at the leading edge of the head and, using a straight edge across the end of the air tube, measure the distance to the end of the tube. A Beckett T501 gauge may also be used.
 - Slide the nozzle line forward or back until this dimension is 1-3/4" for V1 heads. Tighten the acorn nut.
 - Tighten the hex head screw to secure the head adjusting plate to the burner chassis. Then tighten the splined nut and attach the oil connector tube.
- Recheck the "Z" dimension periodically when servicing to ensure the escutcheon plate has not been moved. You will need to reset the "Z" dimension if you replace the air tube or nozzle line assembly.

IDH200LPNG QR OPERATING INSTRUCTIONS

Simplified Sequence of Operation

(Reference **Table 2**)

- Call for heat, Status LED is turned on.
- Control performs safe-start check.
- If safe-start fails, control will flash all 3 LEDs.
- If safe-start passes, control checks for presence of flame.
- If flame is present, control will enter hold state until flame is no longer present. Flame LED and Status LED will flash until flame is no long present.
- If flame is not present, control will check status of air proving switch. If switch is closed (indicating the air proving switch is stuck) control will enter Lockout No Retry or Lockout with Retry.
- If the air proving switch is open, the motor will start. Once the air proving switch closes, pre-purge will begin (1-240 seconds). Pre-purge or ignition timings will not start until the air proving switch closes.
- The air proving switch must close to prove combustion air is present. If switch fails to close during the specified period, the control will enter Lockout No Retry or Lockout with Retry.
- When pre-purge is completed, the control checks the gas valve relay. If the relay test fails, the control will restart or lock out. If the relay test is passed, the control turns on the igniter and the gas valve. MV LED will turn on.
- Spark continues until flame is proved or until the end of ignition timing.
- The spark is off when flame is sensed. The Flame LED is turned on when flame is sensed. The gas valve and MV LED remain energized.
- If flame is not proved, the control will enter Lockout No Retry, Lockout with Retry or the inter-trial waiting period. The Status LED will:
 - Flash rapidly for Lockout with No Retry
 - Flash slowly with the motor on for inter-trial waiting
 - Flash slowly with the motor off for Lockout with Retry

Table 2 - Operating Sequence

	SEQUENCE					
LEDs	Call for Heat	Motor Start	Pre-purge	Ignition	Run	End Call for Heat
	 Status LED turns on	 Status LED ON	 Status LED Flashes	 Status, MV LEDs On	 Status, MV, Flame LEDs On	 LEDs Off
Timers & Timings			Pre-purge Timer 1 - 240 Seconds	Ignition Trial Timer 4 - 15 Seconds		
Flame Check	On	On	On	On	On	Off
Motor/Blower		Blower Starts	On	On	On	Off
Air Switch Check	On	Air Switch Closes	On	On	On	
Igniter				On	Off	Off
Gas Valve				On	On	Off

IDH200LPNG QR OPERATING INSTRUCTIONS

LED Key: ○ = OFF ● = ON ☀ = FLASHING	For below charts, "Troubleshooting" & "Troubleshooting Sequence" sections.
---	--

Table 3 - Normal LED Sequence

LED	LED STATE	CONTROL STATE
<div style="border: 1px solid black; padding: 2px; display: flex; flex-wrap: wrap;"> <div style="margin-right: 10px;">FLAME ○</div> <div style="margin-right: 10px;">MV ○</div> <div style="margin-right: 10px;">STATUS </div> </div>	All LEDs off	No call for heat or no power to appliance
Note: On a call for heat, after the motor/blower starts, the air proving switch must close before pre-purge or trial for ignition timers can start. The Status LED may turn on momentarily while waiting for the air pressure switch to close. If pre-purge is set for 1 second, once the air pressure switch closes, the control will move directly to trial for ignition without flashing the Status LED for pre-purge.		
<div style="border: 1px solid black; padding: 2px; display: flex; flex-wrap: wrap;"> <div style="margin-right: 10px;">FLAME ○</div> <div style="margin-right: 10px;">MV ○</div> <div style="margin-right: 10px;">STATUS </div> </div>	Status LED flashes slowly (once per second) but only if control is set up for pre-purge of 2 seconds or more	Pre-purge or waiting period between trials for ignition, motor should be running
<div style="border: 1px solid black; padding: 2px; display: flex; flex-wrap: wrap;"> <div style="margin-right: 10px;">FLAME ○</div> <div style="margin-right: 10px;">MV ●</div> <div style="margin-right: 10px;">STATUS </div> </div>	Status and MV LEDs on continuously	Trial for Ignition, motor should be running and ignition should be sparking
<div style="border: 1px solid black; padding: 2px; display: flex; flex-wrap: wrap;"> <div style="margin-right: 10px;">FLAME ●</div> <div style="margin-right: 10px;">MV ●</div> <div style="margin-right: 10px;">STATUS </div> </div>	Status, Flame and MV LEDs all on continuously	Main flame has been proved, Control is in run mode and will continue in run mode until call for heat ends



Table 4 - Additional LED Diagnostic Help

LED	LED STATE	CONTROL STATE
<div style="border: 1px solid black; padding: 2px; display: flex; flex-wrap: wrap;"> <div style="margin-right: 10px;">FLAME ○</div> <div style="margin-right: 10px;">MV ○</div> <div style="margin-right: 10px;">STATUS </div> </div>	Status LED is flashing quickly, 3 times per second	Control is in lockout no retry, follow reset steps under troubleshooting box "If the red Status LED is flashing quickly"
<div style="border: 1px solid black; padding: 2px; display: flex; flex-wrap: wrap;"> <div style="margin-right: 10px;">FLAME ○</div> <div style="margin-right: 10px;">MV ○</div> <div style="margin-right: 10px;">STATUS </div> </div>	Status LED is flashing slowly (once per second) and burner motor is <u>off</u>	Control is in lockout with retry, control is in 1-8 hour waiting period between ignition trials, follow troubleshooting under "If the red Status LED is flashing slowly"
<div style="border: 1px solid black; padding: 2px; display: flex; flex-wrap: wrap;"> <div style="margin-right: 10px;">FLAME </div> <div style="margin-right: 10px;">MV </div> <div style="margin-right: 10px;">STATUS </div> </div>	Status, Flame and MV LEDs all flashing	Control failure - internal error, try resetting the control once, if problem reoccurs, replace the control
<div style="border: 1px solid black; padding: 2px; display: flex; flex-wrap: wrap;"> <div style="margin-right: 10px;">FLAME </div> <div style="margin-right: 10px;">MV ○</div> <div style="margin-right: 10px;">STATUS </div> </div>	Status and Flame LEDs flashing	Flame has been sensed when flame should not be present, follow troubleshooting under "If the red Status and yellow Flame LEDs are both flashing"
<div style="border: 1px solid black; padding: 2px; display: flex; flex-wrap: wrap;"> <div style="margin-right: 10px;">FLAME </div> <div style="margin-right: 10px;">MV ●</div> <div style="margin-right: 10px;">STATUS </div> </div>	Status and MV LEDs on continuously, Flame LED flashing	Flame signal is weak, follow troubleshooting steps under "Is the yellow Flame LED on?"

Troubleshooting







Check LEDs First - Find the box on the left that matches the LED display you are seeing. When all three LEDs are on continuously and the burner is lit, the system is operating normally. The troubleshooting information is intended as a guide and may not cover all possibilities in every application.

Table 5 - Troubleshooting

	<p>If the red Status LED is off:</p> <ul style="list-style-type: none"> ▪ No power to the control. ▪ Check that the thermostat or controller is calling for heat. ▪ Check for power to the appliance. ▪ Check that limit is closed, check that the thermal (blocked vent) switch is closed. ▪ Check for power to the system transformer. ▪ Check all wiring and secure all connections ▪ With the controller calling for heat, use a volt meter to measure 24 volts to the control. Place one probe on the right thermostat terminal and the other probe on an unpainted portion of the burner. If no voltage is measured, there is no power to the control. If 24 volts is measured, move the first probe from the right thermostat terminal to the left thermostat terminal. If 24 volts is measured on the left terminal and the red Status LED is off, replace the control. If no voltage is measured on the left terminal, the thermal switch is open.
	<p>If only the red Status LED is on steadily:</p> <ul style="list-style-type: none"> ▪ If motor is off—air pressure switch is closed (stuck), will wait for switch to open. ▪ If motor is on—waiting for air pressure switch to close. ▪ If switch fails to open or close within a specified time, control will lockout. ▪ If switch opens and closes properly, control will move to pre-purge.
	<p>If the red Status LED is flashing quickly (3 times per sec.)</p> <ul style="list-style-type: none"> ▪ Control is in Lockout with Limited or No Retry ▪ Check the air pressure switch. If the air pressure switch is stuck in the closed position or if the air pressure switch has been jumpered, the control could lockout. The control could also lockout if the air pressure switch fails to close when the motor/blower starts. ▪ Push reset button or remove power from control for 10 seconds and restart ignition sequence with a call for heat. If control is a non-volatile lockout model (7590C), the control can only be reset using the reset button while the module is powered. If the motor/blower is off and the red Status LED remains on steadily, the air pressure switch is stuck in the closed position. If the motor/blower is running and the red Status LED remains on steadily for more than a few seconds, it is likely the issue is with the air pressure switch or the air blower (or a blockage). ▪ If the control completes pre-purge and locks out at the beginning of the trial for ignition, the control has likely failed the gas valve relay check, replace the control. ▪ If the control completes the trial for ignition and the burner does not light properly, follow the troubleshooting sequence.

IDH200 QR LPNG TROUBLE SHOOTING GUIDE

Table 5 (continued)

	<p>If the red Status LED is flashing slowly (1 time per sec.)</p> <ul style="list-style-type: none"> ▪ If motor/blower is running, control is in pre-purge or control is in a waiting period between trials for ignition. If motor is not running, control is in Lockout with Retry waiting to retry in 1-8 hours (reset control). ▪ The pre-purge period is 1-240 seconds, depending on setting. ▪ The control waiting period is 90 seconds to 5 minutes, depending on setting. ▪ Either wait for pre-purge/waiting period to finish, OR ▪ Turn thermostat or controller off for 5 minutes to let accumulated gas disperse, (LED should turn off) then turn thermostat or controller back on to restart ignition sequence. Allow the control to go through pre-purge, if any, and complete the trial for ignition sequence. ▪ If motor is not running, control is in lockout with retry and is waiting to retry in 1-8 hours. Allow time for gas to disperse. Reset control by removing power for 10 seconds and restart ignition sequence with a call for heat. If the motor/blower is off and the red Status LED remains on steadily, the air pressure switch is stuck in the closed position. If the motor blower is running and the red Status LED remains on steadily for more than a few seconds, it is likely the issue is with the air pressure switch or the air blower (or a blockage). ▪ If burner does not light properly, follow the troubleshooting sequence.
	<p>If the red Status LED and green MV LED are on continuously</p> <ul style="list-style-type: none"> ▪ Call for heat is active. ▪ Control is powered. ▪ Igniter should be energized and sparking at the burner head, gas valve should be open, motor should be running. ▪ If no sparking at the burner, follow the troubleshooting sequence.
	<p>If the Status and MV LEDs are on continuously and the Flame LED is flashing</p> <ul style="list-style-type: none"> ▪ The flame signal is weak ▪ Try to improve flame signal strength by following steps in the Troubleshooting Sequence under "Is the yellow Flame LED on?"
	<p>If the red Status and yellow Flame LEDs are both flashing</p> <ul style="list-style-type: none"> ▪ The control is sensing flame when no flame should be present. ▪ The control enters a hold state, this is not a lockout. ▪ Control will remain in hold state until flame is no longer present. ▪ Check for flame in the burner. ▪ Check gas valve for leakage through the valve, replace valve if leaking. ▪ Measure gas pressure to make sure pressure does not exceed valve rating. ▪ Maximum gas pressure rating will often be listed on gas valve. ▪ If pressure is too high, adjust gas pressure at system regulator or contact gas utility for help. ▪ High gas pressure can damage gas valves, if gas pressure exceeding the rating of the valve is measured, the gas valve should be replaced.
	<p>If all the LEDs are flashing</p> <ul style="list-style-type: none"> ▪ An internal error has been detected, try resetting the control once, if the problem reoccurs, replace the control
	<p>If all the LEDs are on continuously and the burner is lit</p> <ul style="list-style-type: none"> ▪ The control is in the run mode and is functioning properly.

Troubleshooting Sequence

Start with gas supply off and set thermostat or controller to call for heat.

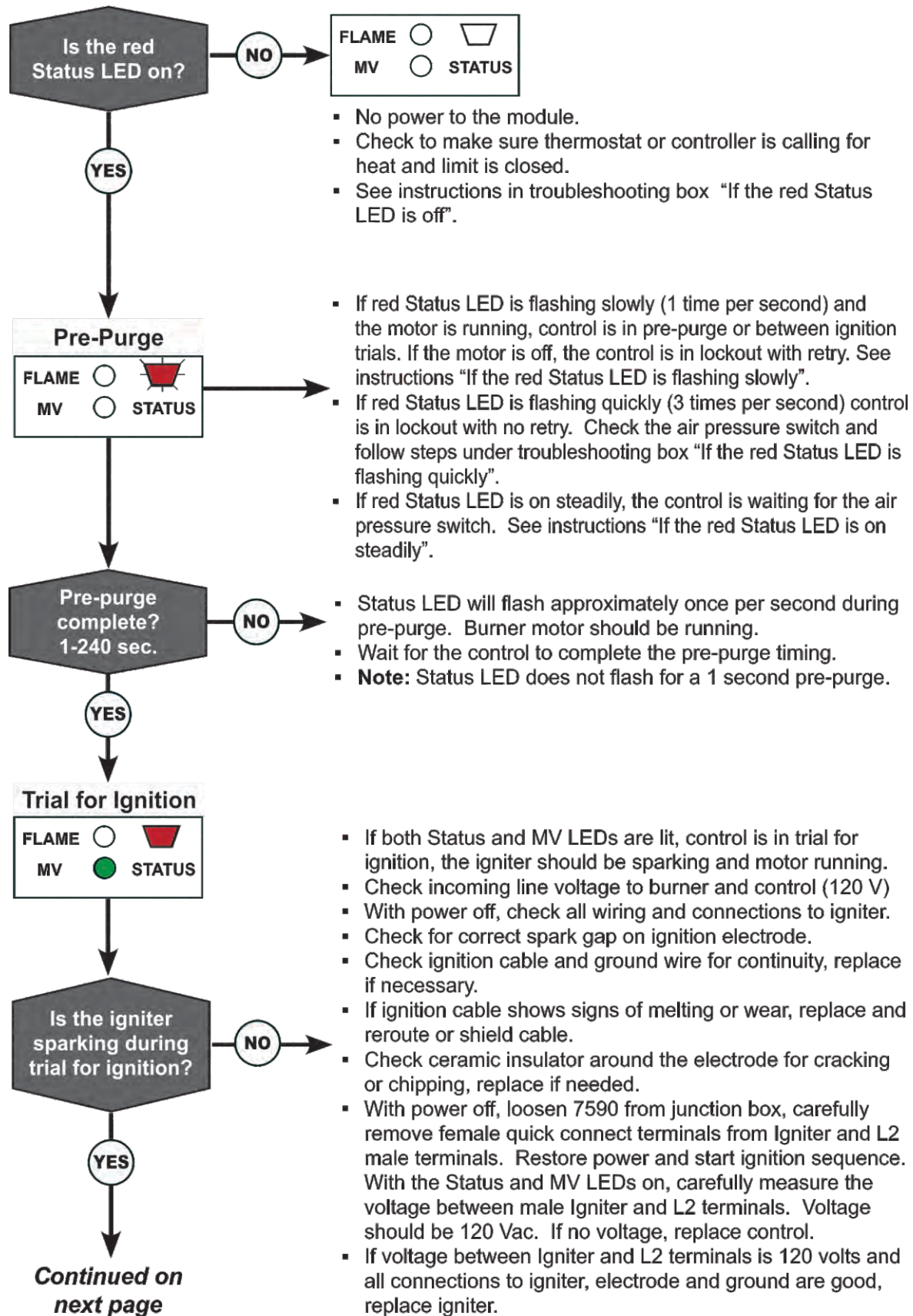

Troubleshooting Sequence (continued)

- ▶ Turn the thermostat or controller off to end the call for heat.
- ▶ Turn on the gas supply.
- ▶ Turn the thermostat or controller back on to call for heat.

The ignition sequence will start over.

Repeat the steps above and proceed to lighting the burner.

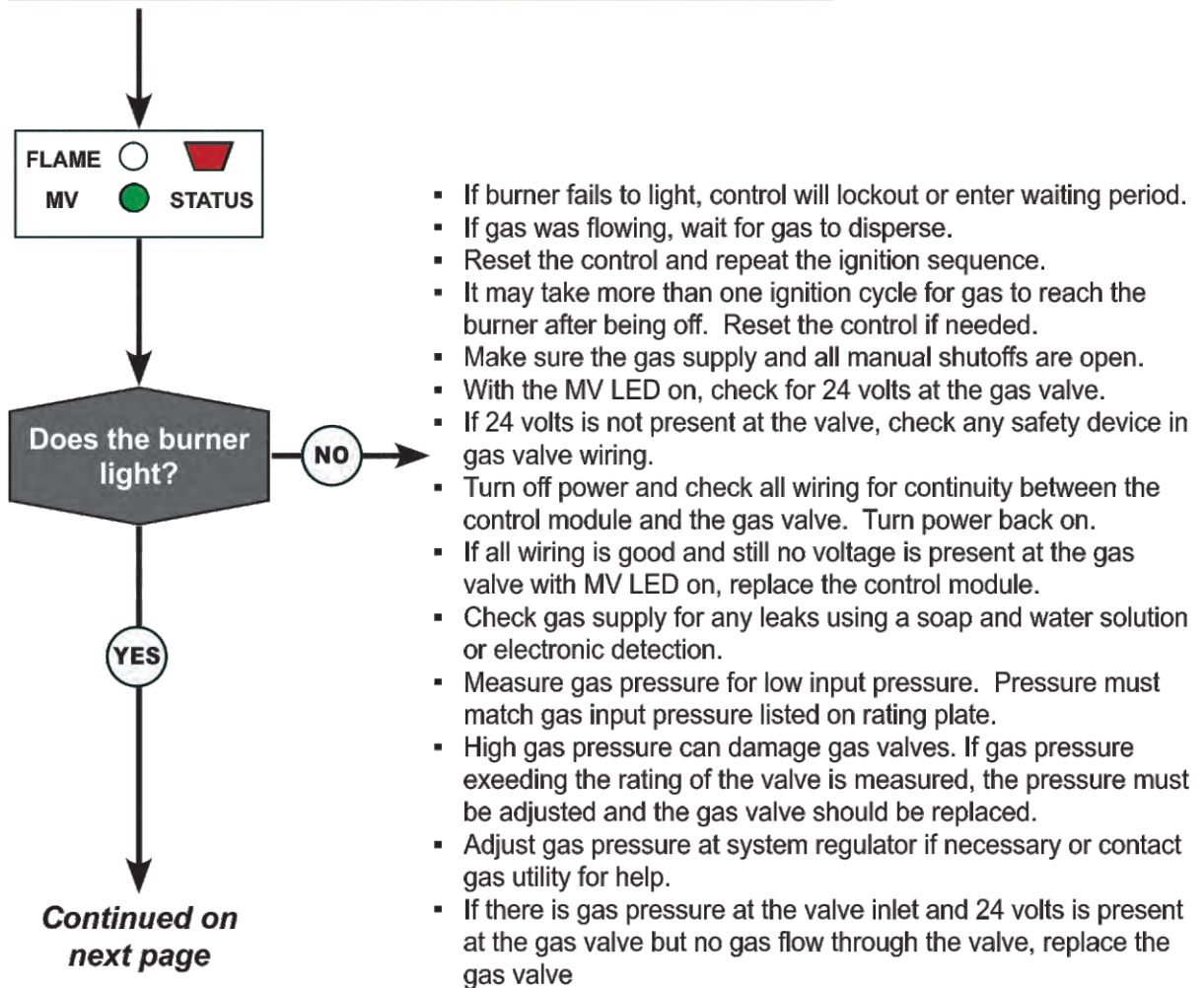

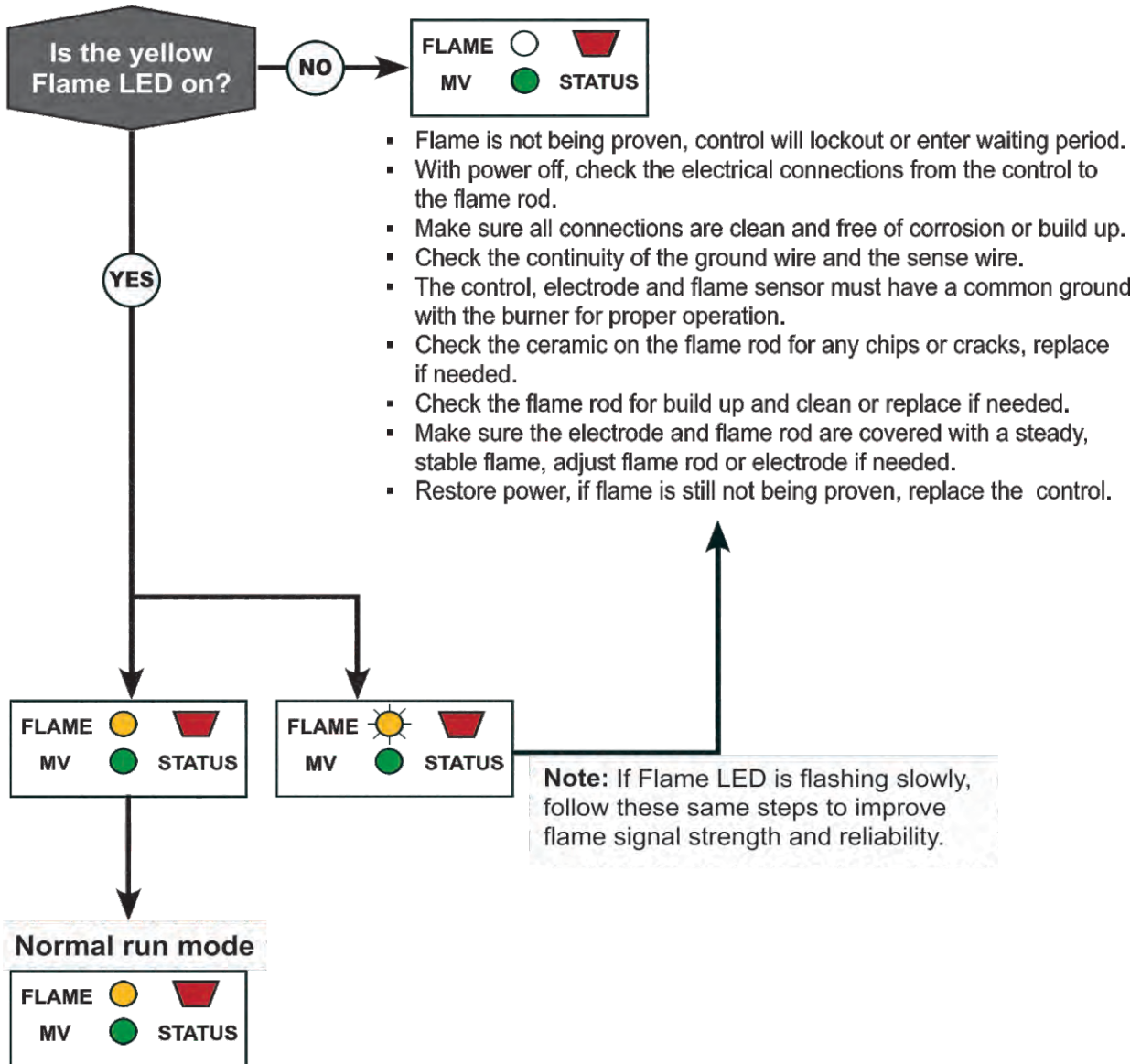

- Flame is not being proven, control will lockout or enter waiting period.
- With power off, check the electrical connections from the control to the flame rod.
- Make sure all connections are clean and free of corrosion or build up.
- Check the continuity of the ground wire and the sense wire.
- The control, electrode and flame sensor must have a common ground with the burner for proper operation.
- Check the ceramic on the flame rod for any chips or cracks, replace if needed.
- Check the flame rod for build up and clean or replace if needed.
- Make sure the electrode and flame rod are covered with a steady, stable flame, adjust flame rod or electrode if needed.
- Restore power, if flame is still not being proven, replace the control.

Note: If Flame LED is flashing slowly, follow these same steps to improve flame signal strength and reliability.

Normal run mode



- When the burner lights successfully, turn the thermostat or controller off to end the call for heat.
- The burner should go out quickly. All LEDs on the control should go out.
- If the burner remains lit for more than a few seconds, and the MV LED is out, replace the gas valve.
- If the LEDs remain lit, there is still power to the control, check the thermostat or controller for proper operation.
- Repeat the ignition sequence several times to make sure the system is operating properly.

IDH200QR OIL BURNER PARTS

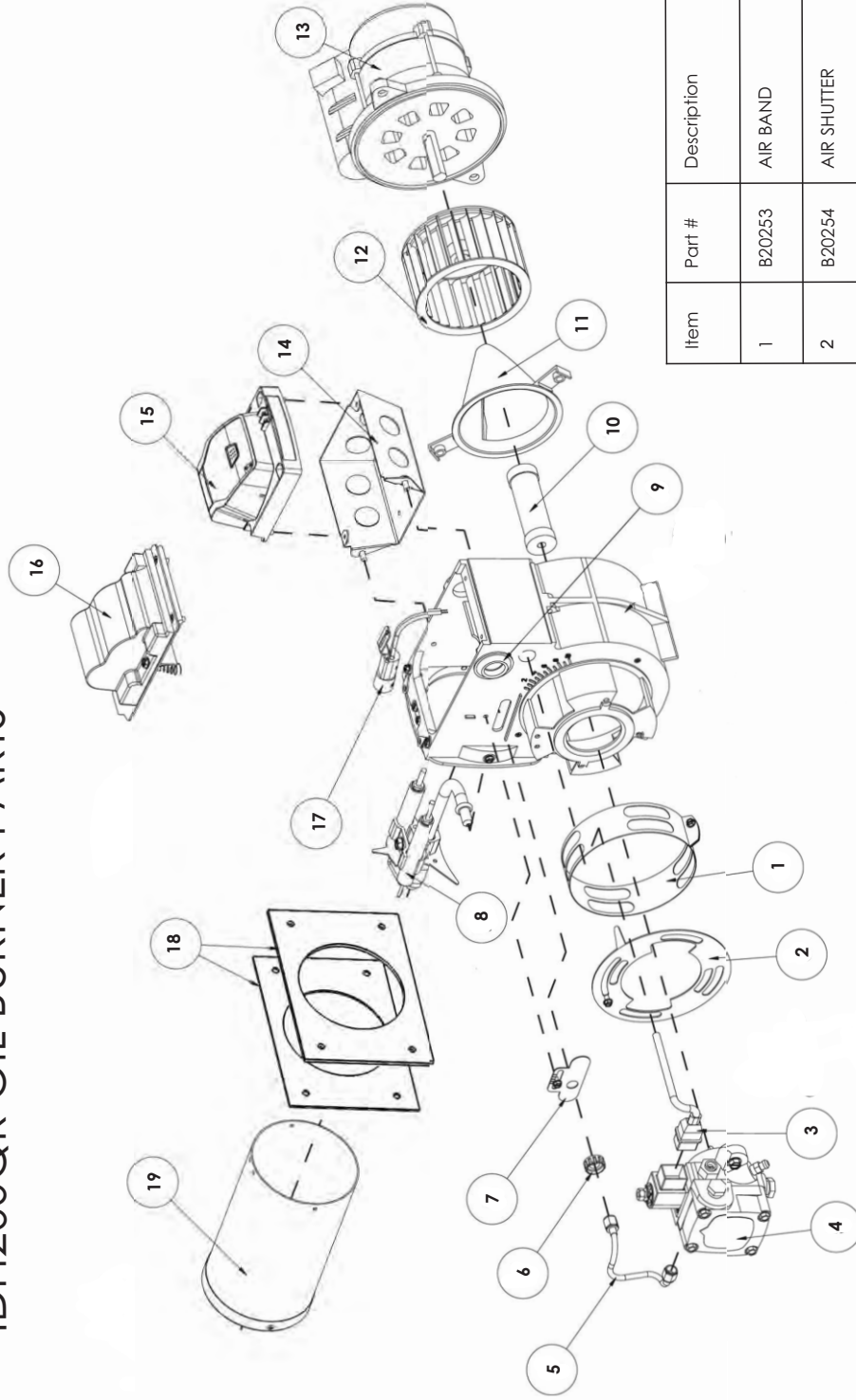

Item	Part #	Description	Item	Part #	Description
1	B20253	AIR BAND	11	B20142	AIR GUIDE
2	B20254	AIR SHUTTER	12	BG 21010	BLOWER WHEEL
3	48137	VALVE CORDSET	13	B20140	1/7 HP BURNER MTR
4	B20139A	CLEAN-CUT PUMP	14	BG 21009	ELECTRICAL BOX
5	48152	COPPER LINE	15	50147	GENISYS CNTRL
6	B48267	SPLINED NUT	16	B20138	IGNITOR
7		HEAD ADJ PLATE	17		CAD CELL
8		SEE INSET	18		BURNER FLANGE
9		HOLE PLUG	19		AIR TUBE
10	B20183	COUPLING			

Item	Part #	Description
A	B48266	HEAD ASSEMBLY
B	B20262	ELEC. INSULATOR KIT
C	B30268A	ELECTRODE ASSEMBLY

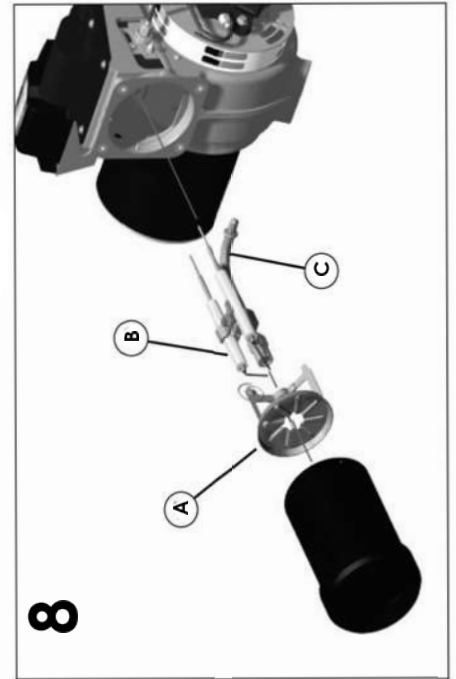

8

IDH OIL TROUBLE SHOOTING GUIDE

ALWAYS DOUBLE CHECK FOR SUFFICIENT POWER , GAUGE OF CORD (SEE TOP OF PAGE #5) AND PROPER FUEL SUPPLY. POWER AND FUEL SUPPLY MUST BE SHUT OFF/DISCONNECTED BEFORE REMOVING OR REPLACING ANY COMPONENTS ON THE HEATER.

- 1. Unit is turned on, nothing happens after 5 second safe start.**
 - a. Ensure proper voltage coming in, 115V AC.
 - b. Check for power on both sides of burner fuse. If no power, then check toggle switch. If power on one side, replace fuse. If power on both sides, go to **c**.
 - c. Check black wire from primary control. If no power there, remove high limit cover & check for power on both sides of high limit. If power on one side only, replace high limit. If power on both sides, go to **d**.
 - d. Ensure thermostat contacts on primary control (T and T) are jumpered out.
 - e. Make sure light on primary control is not flashing. If so, push button to reset.
 - f. Check manual reset button on motor and wiring connection to motor. If reset pushed and power going to motor, nothing is happening, replace burner motor.
 - g. On neutral line (white wires) make sure all connections are tight and secure, and unit is properly grounded. With AC voltage tester, check white (neutral lines) for power (one on ground, one on neutral). If over 5 volts, check polarity. If polarity correct, check wires individually for power to determine leak source, then replace leak source.
 - h. If power coming into black wire on primary control, but no power out to orange wire, replace primary control.
 - i. If green light on primary control stays on, check to ensure transformer door is closed properly as cad cell is detecting light. Check cad cell is working. If light stays on and no obvious areas open, check OHM reading across two yellow wires. If you get a reading, replace cad cell. If you get no OHM reading from cad cell, replace primary control if light still on.
- 2. Burner motor starts but unit will not fire.**
 - b. Remove electrode assembly and check isolators for cracks or chips in the porcelain. Make sure electrode setting is proper. For electrode adjustments, please turn to page 9.Clean assembly if there is any soot or oil..
 - c. The nozzle should be checked and ensure it is not clogged or blocked. Make sure nozzle is not loose.
 - d. Ensure air shutters are properly set to factory specifications.
 - e. Check for power on violet line on primary control. After pre-purge, if no power sent to violet line, replace primary control. If power on violet line, remove copper fuel line at electrode assembly to ensure fuel is coming out. If no fuel there, replace solenoid valve.
 - f. At the bleeder screw, check for proper out pump pressure (see maintenance section). If low or no pump pressure, go to **g**
 - g. Check oil filter, oil pick up tube and oil lines to ensure free flow and they are not clogged or dirty.
 - h. Check electrical polarity and grounding.
- 3. Burner fires then locks out.**
 - a. Check oil pressure to ensure solenoid valve is opening. Check oil flow system, filter, pick up tubes and lines.
 - b. The nozzle should be checked to ensure it is clean and emitting a good spray pattern, as this could affect the cad cell operation.
 - c. Cad cell (flame detector) could be defective. Disconnect yellow cad cell wires from primary control. Start unit and when it fires, connect jumper across connections on primary control. If unit continues to run, then check cad cell alignment with burner, clean face with a soft cloth and ensure no external light is affecting it. With an ohmmeter, check resistance across cad cell leads with machine running and primary control cad cell leads jumpered out. If resistance over 1200 OHMS, cad cell should be replaced. If unit locks out with jumper, replace primary control.

IDH TROUBLE SHOOTING GUIDE

3.
 - d. Wires between cad cell and primary control should be checked to see that they are not pinched or crimped..
 - e. Prime fuel pump by loosening bleeder screw till steady stream of fuel comes out to ensure no air or bubbles in fuel line..
 - f. **If unit locks out three times in succession, it will go into restricted lock out mode. To reset, hold down reset button for 15 seconds until LED flashed twice. The unit will then resume in normal operating mode.** After verifying primary control is not in lockout & light continues to flash, replace primary control.
 - g. Check polarity, ground & voltage must be between 108-132v AC.
 - h. Make sure high limit is functioning properly.
4. **Smoky fire**
 - a. Check nozzle, make sure is tight and not clogged.
 - b. Check combustion chamber for cracks or burnt out.
 - c. Check air band settings. (Air shutter and/or air band may be closed too much-restricting combustion air.
 - d. Check pump pressure.
 - e. Check slide plate to make sure it is in correct position.(See page 9 for settings)If necessary, open slightly.
 - f. Check recommended settings if using #2 fuel in cold ambient temperatures
5. **Delayed ignition**
 - a. Check for proper electrode setting.
 - b. Check the isolators for cracks or a conducting coat of soot or oil. Cracks sometimes occur under the electrode bracket, causing a short circuit.
 - c. Check to see that the air shutter is not overly open-too much air will blow out flame.
 - d. Check to ensure pump pressure is properly set..
 - e. Change nozzle.
 - f. Check fuel filter, replace if necessary.
 - g. Ensure draft or wind is not blowing out flame-add 3' stack.
6. **Main fan will not come on, unit shuts down on high limit.**
 - a. Check temperature feeler, make sure it is in properly.
 - b. Jumper out fan switch to test motor. If you have voltage to motor and still does not start, replace motor. Check line voltage to ensure proper voltage. Also checks amp draw on motor. Motor may be running too hot and not run due to thermal overload being tripped.
 - c. Replace fan switch if you have power on one side after unit heating up it does not make
 - d. Replace high limit as it may be tripping too soon and not giving fan switch time to engage.
 - e. Ensure fan switch temperature is correct for weather conditions (see page 8 for settings)
7. **Unit on, but cycles on high limit**
 - a. Check air flow, ensure both ducts are in place and clear of obstruction and straight.
 - b. Check pump pressure, unit could be over firing.
 - c. Check nozzle that proper size of nozzle is installed.
 - d. Change high limit.
 - e. **Maximum duct length with 2 X 12" outlet is 24' on each side. 1 X 16" outlet, length is 45'. Any longer will create back pressure in the unit and trip the high limit. *SEE PAGE 2 FOR SPECS***
 - f. Fuel type- #2 will increase BTU output @cold ambient temperatures resulting in overheating.
8. **Combustion chamber turns red.**
 - a. Nozzle may be firing side ways (replace or adjust)
 - b. Clogged nozzle (replace)
 - c. Temperature feeler not on properly or missing (Must be touching heat exchanger)
 - d. High limit not functioning (replace)
 - e. Excessive pump pressure. Check and reset if necessary
 - f. Fuel type-see page 7 for recommended settings.

Sequence of Operation for Genisys Controller



Burner States

Standby:

The burner is idle, waiting for a call for heat.

Valve-On Delay:

The igniter and motor are on while the control delays turning on the oil solenoid valve for 45 seconds..

Trial For Ignition:

The oil solenoid valve is energized. A flame should be established within the factory set trial for ignition time ("lockout time").

Lockout:

The control has shut down for one of the following safety reasons:
a. The trial for ignition (lockout) time expired without flame being established.

b. The cad cell detected flame at the end of the Valve On Delay state.

To reset the control from lockout click the button 1-second.

NOTE: A recurrence of the above failure modes or a failed welded relay check could cause the control to enter a Hard Lockout state that must be reset only by a qualified service technician. To reset from Hard Lockout, hold the reset button for 15 seconds until the yellow light turns on.

Ignition Carryover:

Once flame is established, the igniter remains on to ensure flame stability.

Run:

The flame is sustained until the call for heat is satisfied. The burner is then sent to Motor-Off Delay, if applicable, or it is shut down and sent to Standby.

Recycle:

If the flame is lost while the burner is firing, the control shuts down the burner, enters a 60 second recycle delay, and repeats the ignition sequence. The control will continue to Recycle each time the flame is lost, until it reaches a pre-set time allotment. The control will then go into Hard Lockout instead of recycle. This feature prevents excessive accumulation of oil in the appliance firing chamber.

Motor-Off Delay:

If applicable, the oil solenoid valve is turned off and the control delays turning the motor off for the set motor-off delay time before the control returns to standby.

Pump Prime:

The igniter and motor are on with the oil solenoid valve energized for 4 minutes. During Pump Prime mode, the cad cell is disregarded, allowing the technician to prime the pump without having to jumper the cad cell.

IDH200QR GAS BURNER PARTS

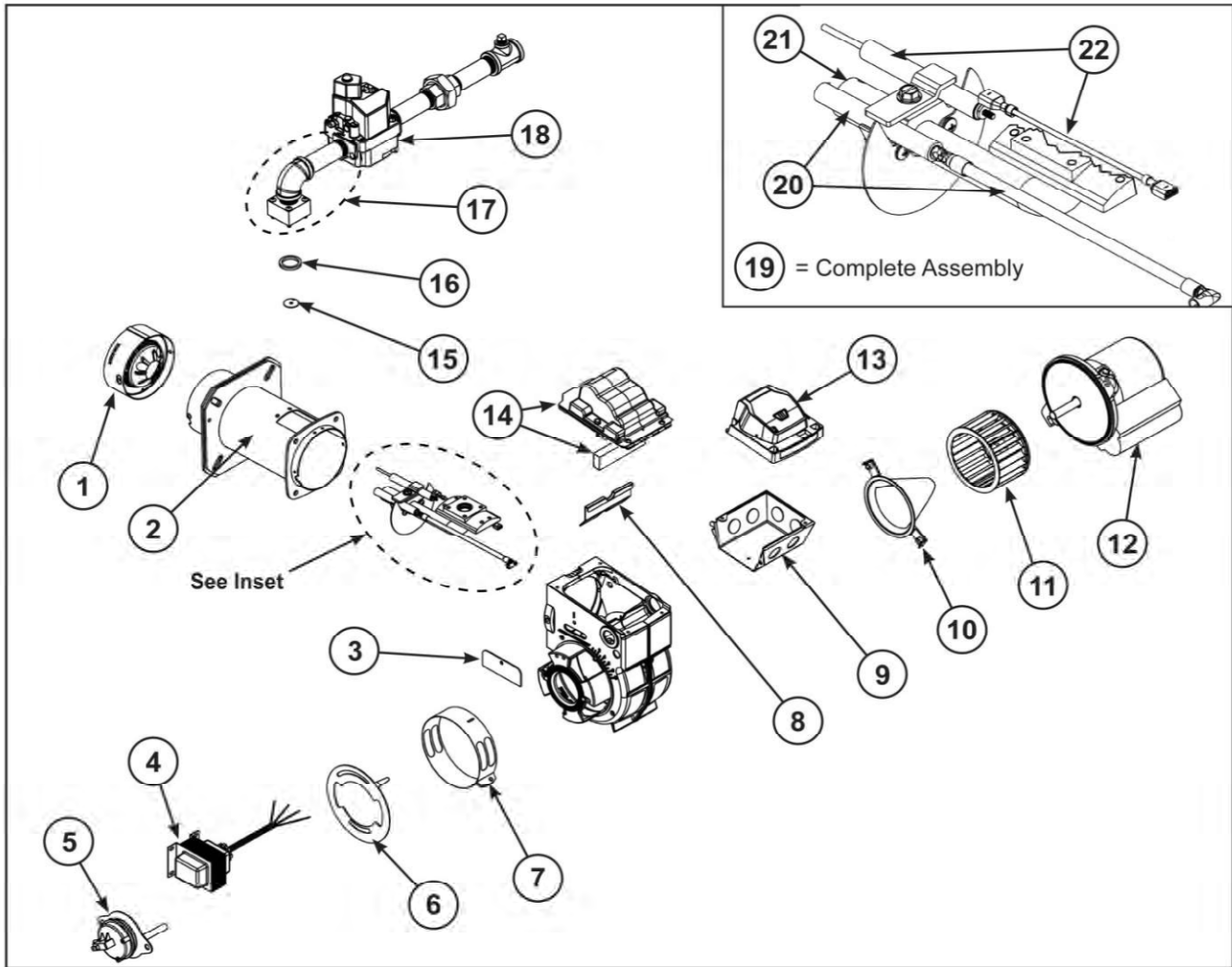

Item	Part #	Description	Item	Part #	Description
1	BG 21002	Cg4 HEAD/SHROUD ASSY	12	B20140	1/7 HP BURNER MOTOR
2	BG 21003	AIR TUBE ASSY FOR IDH200	13	BG 21011	GENISYS PRIMARY (GAS)
3	BG 21004	COVER PLATE	14	BG 21012	IGNITOR AND GASKET
4	BG 21005	GAS TRANSFORMER IDH	15	BG 21013	NAT GAS ORIFICE IDH200
5	BG 21006	AIR PROVING SWITCH	16	BG 21014	O RING
6	B20254	SHUTTER	17	BG 21015	ASSEMBLY, PIPE NIPPLE
7	BG 21007	AIR BAND	18	BG 21016	GAS VALVE
8	BG 21008	AIR BAFFLE	19	BG 21017	GAS GUN ASSY FG4
9	BG 21009	ELECTRICAL BOX	20	BG 21018	ELECTRODE/IGN LEAD
10	B20142	AIR GUIDE	21	BG 21019	NOZZLE FOR CG4 GAS
11	BG 21010	BLOWER WHEEL FOR CG4	22	BG 21020	FLAME ROD/WIRE ASSY

LIMITS, FAN SWITCHES AND TEMPERATURE FEELERS

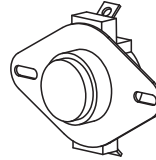

ADJUSTABLE FAN SWITCH 90-130°F (48111B)
ALL MODELS

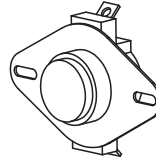

OHV HIGH LIMIT
C9648
HIGH LIMIT L220 - 40F
(48110A)



FEELER
ALL MODELS
(48171)

Indoor and outdoor settings of fan switch

Indoors & if surrounding air is warm i.e. -5C/23F-Fan switch should be set to 115' or higher so as to shut down unit when heat exchanger is properly cooled, also keeps fan motor from excessive running on when discharging cooler air.

Outdoor-Fan switch should be set between 100'-90'. The colder the temperature the lower the setting.