

# ***PowerLite***

# **MAX**

## **INSTRUCTION MANUAL MODE D'EMPLOI MANUAL DE INSTRUCCIONES**

**HIGH PRESSURE COMPRESSOR  
COMPRESSEUR À HAUTE PRESSION  
COMPRESOR DE ALTA PRESIÓN**



**AKHL1320E**

**INDEX  
INDEX  
ÍNDICE**

**ENGLISH Page 7 to 23  
FRANÇAIS Pages 24 à 41  
ESPAÑOL Página 42 a 59**

### **⚠ WARNING**

**BEFORE USING THIS COMPRESSOR, STUDY THIS MANUAL TO ENSURE SAFETY WARNING AND INSTRUCTIONS. KEEP THESE INSTRUCTIONS WITH THE TOOL FOR FUTURE REFERENCE.**

### **⚠ AVERTISSEMENT**

**AVANT D'UTILISER CE COMPRESSEUR, LIRE CE MANUEL ET LES CONSIGNES DE SÉCURITÉ AFIN DE GARANTIR UN FONCTIONNEMENT SÛR. CONSERVER CE MANUEL EN LIEU SÛR AVEC L'OUTIL AFIN DE POUVOIR LE CONSULTER ULTERIEUREMENT.**

### **⚠ ADVERTENCIA**

**ANTES DE UTILIZAR ESTE COMPRESOR, LEA DETENIDAMENTE LAS INSTRUCCIONES Y ADVERTENCIAS DE SEGURIDAD. GUARDE ESTAS INSTRUCCIONES CON LA HERRAMIENTA PARA UNA POSIBLE CONSULTA FUTURA.**

## **DEFINITIONS OF SIGNAL WORDS**

- ⚠ WARNING:** Indicates a potentially hazardous situation which, if not avoided, could result in death or serious injury.
- ⚠ CAUTION:** Indicates a potentially hazardous situation which, if not avoided, may result in minor or moderate injury.
- NOTE:** Emphasizes essential information.

## **DEFINITIONS DES INDICATEURS PRINCIPAUX**

- ⚠ AVERTISSEMENT:** Indique une situation potentiellement à risque qui, si elle n'est pas évitée, peut résulter en un danger mortel ou une blessure grave.
- ⚠ ATTENTION:** Indique une situation potentiellement à risque qui, si elle n'est pas évitée, peut résulter en une blessure mineure ou modérée.
- REMARQUE:** Accentue les informations essentielles.

## **DEFINICIONES DE LOS INDICADORES PRINCIPALES**

- ⚠ ADVERTENCIA:** Indica una situación potencialmente peligrosa que, si no se evita, puede resultar en muerte o lesiones graves.
- ⚠ PRECAUCIÓN:** Indica una situación potencialmente peligrosa, que si no se evita, puede resultar en una herida menor o moderada.
- NOTA:** Destaca las informaciones esenciales.

Fig.A/Abb.A

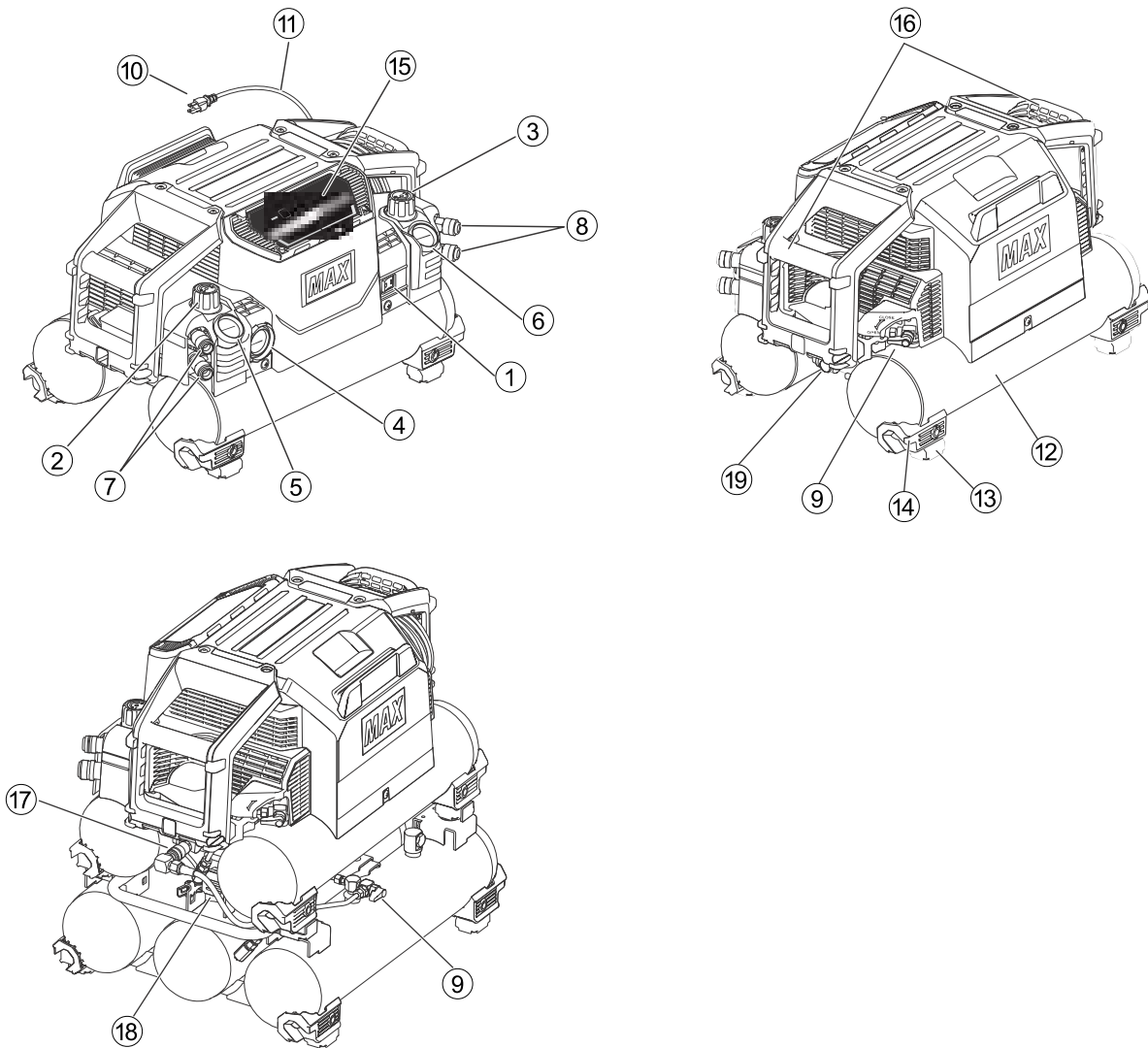
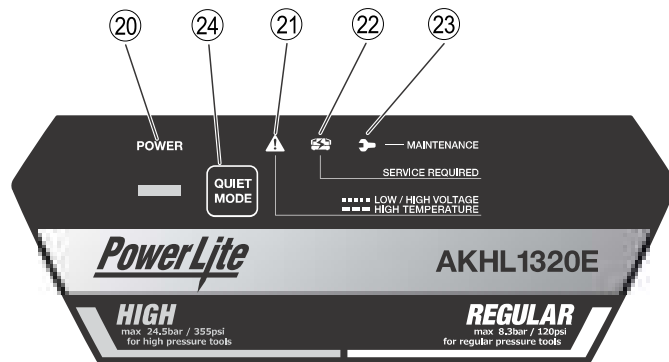
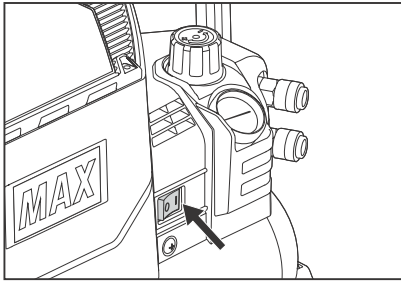

Fig.B/Abb.B



**Fig.C/Abb.C**



**Fig.D/Abb.D**

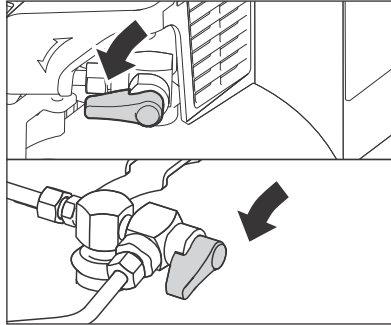

**Fig.E/Abb.E**

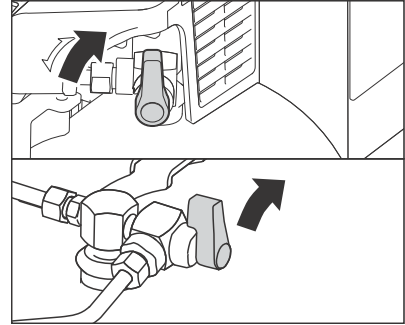

**Fig.F/Abb.F**



**Fig.G/Abb.G**

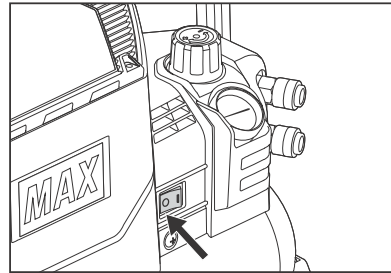

**Fig.H/Abb.H**

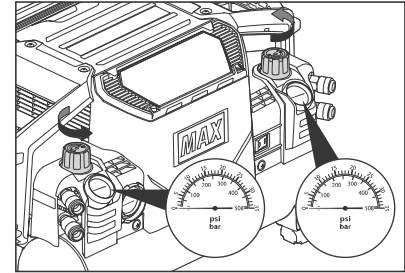

**Fig.I/Abb.I**

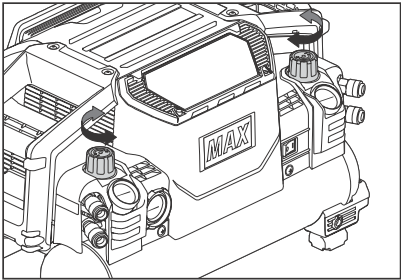

**Fig.J/Abb.J**

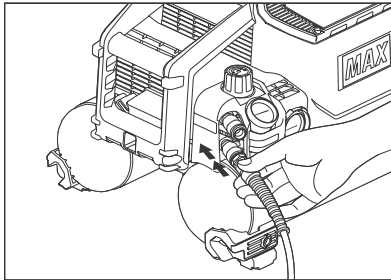

**Fig.K/Abb.K**

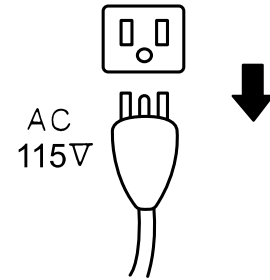

**Fig.L/Abb.L**

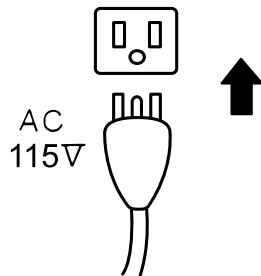

**Fig.M/Abb.M**

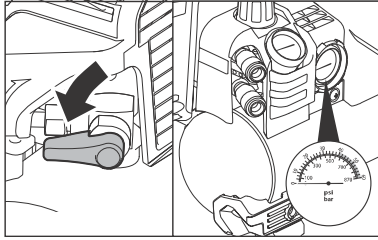

**Fig.N/Abb.N**

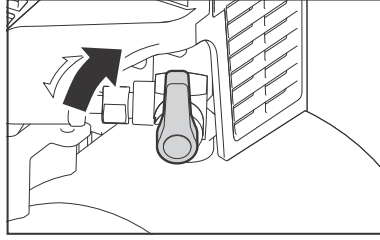

**Fig.O/Abb.O**

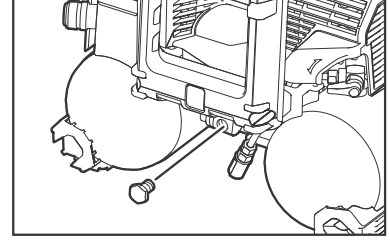

**Fig.P/Abb.P**

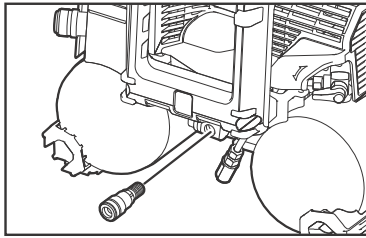

**Fig.Q/Abb.Q**

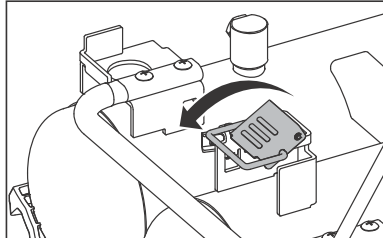

**Fig.R/Abb.R**

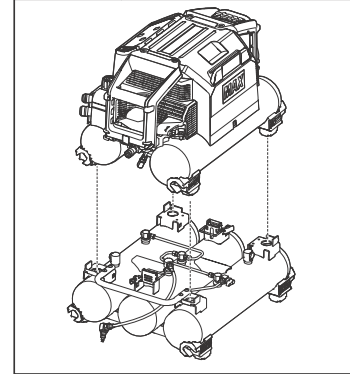

**Fig.S/Abb.S**

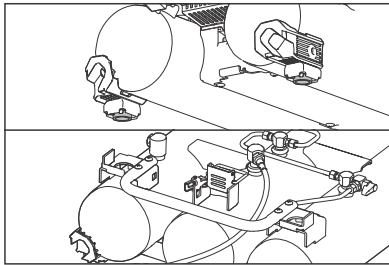

**Fig.T/Abb.T**

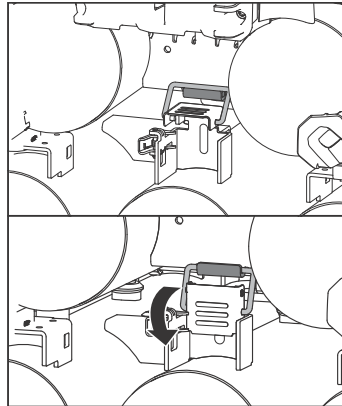

**Fig.U/Abb.U**

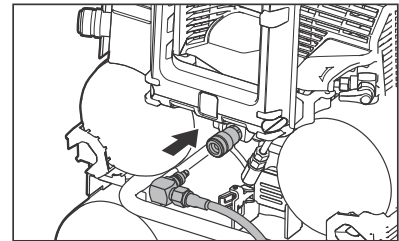

**Fig.V/Abb.V**

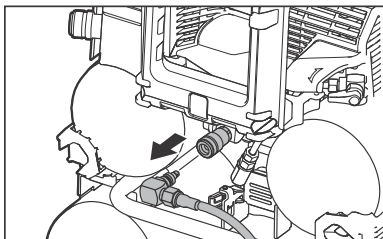

**Fig.W/Abb.W**

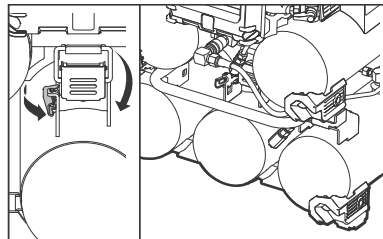

**Fig.X/Abb.X**

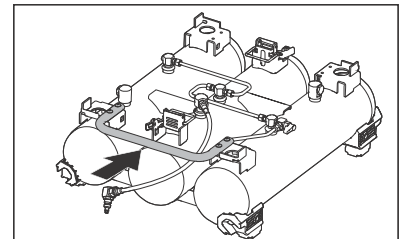



**INSTRUCTION MANUAL**

**INDEX**

1. **SYMBOLS** ..... 7

2. **SAFETY INSTRUCTIONS** ..... 8

3. **SPECIFICATIONS** ..... 12

4. **INSTRUCTIONS FOR OPERATION** ..... 14

5. **PROTECTIVE DEVICE** ..... 20

6. **ABNORMALITIES DURING OPERATION** ..... 20

7. **BUZZER TYPES** ..... 21

8. **HOW TO INSTALL OPTIONAL 1320E TANK** ..... 22

9. **AUTOMATIC ADJUSTMENT OF OPERATING POWER (INVERTER CONTROL)** ..... 22

10. **IN ORDER TO MAINTAIN PERFORMANCE** ..... 23

**!WARNING** BEFORE USING THIS COMPRESSOR, STUDY THIS MANUAL TO ENSURE SAFETY WARNING AND INSTRUCTIONS. KEEP THESE INSTRUCTIONS WITH THE TOOL FOR FUTURE REFERENCE.

**1. SYMBOLS**

The following shows the symbols used for the equipment and this Instruction Manual. Be sure that you understand their meaning before use.



**READ ALL SAFETY WARNINGS AND ALL INSTRUCTIONS.**

Failure to follow the warnings and instructions may result in death serious injury. Save all warnings and instructions for future reference.



**RISK OF ELECTRIC SHOCK**

**! WARNING:** Before doing any work on the compressor it must be disconnected from the power supply.



**RISK OF HIGH TEMPERATURES**

**! CAUTION:** The compressor contains some parts which might reach high temperatures.



**RISK OF ACCIDENTAL START-UP**

**! CAUTION:** The compressor could start automatically in case of a black-out and subsequent reset.



### DO NOT USE IN THE RAIN

Using the compressor in these or similar conditions will increase the risk of electric shock, dangerous malfunction, and overheating.



### WEAR SAFETY GLASSES OR GOGGLES

Danger to the eyes always exists due to the possibility of dust being blown up by the exhausted air or of a fastener flying up due to the improper handling of the tool. For these reasons, safety glasses or goggles shall always be worn when operating the tool.

The employer and/or user must ensure that proper eye protection is worn. Eye protection equipment must conform to the requirements of the American National Standards Institute, ANSI Z87.1 (Council Directive 89/686/EEC of 21 DEC. 1989) and provide both frontal and side protection.

The employer is responsible to enforce the use of eye protection equipment by the tool operator and all other personnel in the work area.

**NOTE:** Non-side shielded spectacles and face shields alone do not provide adequate protection.



### EAR PROTECTION MAY BE REQUIRED IN SOME ENVIRONMENTS

As the working condition may include exposure to high noise levels which can lead to hearing

damage, the employer and user should ensure that any necessary hearing protection is provided and used by the operator and others in the work area.

### WHEN DISPOSING THE MACHINE OR ITS PARTS, FOLLOW THE RELEVANT NATIONAL RULES.



#### Only for EU countries

Do not dispose of electric equipment together with household waste material!

In observance of European Directive 2012/19/EU on waste electrical and electronic equipment and its implementation in accordance with national law, electric equipment that have reached the end of their life must be collected separately and returned to an environmentally compatible recycling facility.

The compressors are manufactured to meet RoHS directives.

## 2. SAFETY INSTRUCTIONS



### ⚠ WARNING

TO AVOID SEVERE PERSONAL INJURY OR PROPERTY DAMAGE BEFORE USING THE TOOL, READ CAREFULLY AND UNDERSTAND THE FOLLOWING "SAFETY INSTRUCTIONS": FAILURE TO FOLLOW WARNINGS COULD RESULT IN DEATH OR SERIOUS INJURY.

### PRECAUTIONS ON USING THE COMPRESSOR

#### IMPORTANT INFORMATION

Most accidents that result from compressor operation and maintenance are caused by the failure to observe basic safety rules or precautions. An accident can often be avoided by recognizing a potentially hazardous situation before it occurs, and by observing appropriate safety procedures. Basic safety precautions are outlined in the "SAFETY" section of this Instruction Manual and in the sections which contain the operation and maintenance instructions.

Hazards that must be avoided to prevent bodily injury or machine damage are identified by ⚠ WARNINGS on the compressor and in this Instruction Manual.

Never use this compressor in a manner that has not been specifically recommended by manufacturer, unless you first confirm that the planned use will be safe for you and others.



DEATH OR SERIOUS BODILY INJURY COULD RESULT FROM IMPROPER OR UNSAFE USE OF COMPRESSOR, TO AVOID THESE RISKS, FOLLOW THESE BASIC SAFETY INSTRUCTIONS. HIGH PRESSURE COMPRESSOR PROVIDES BOTH HIGH PRESSURE AND REGULAR PRESSURE AIR. FOR USAGE OF HIGH PRESSURE AIR, HIGH PRESSURE COMPRESSOR IS DESIGNED ONLY FOR MAX POWERLITE NAILERS AND POWERLITE HOSE. UNSPECIFIED USAGE WILL CAUSE SERIOUS ACCIDENTS.

**1. NEVER TOUCH MOVING PARTS**

Never place your hands, fingers or body parts near the compressor's moving parts.

**2. NEVER OPERATE WITHOUT ALL GUARDS IN PLACE**

Never operate the compressor without all guards or safety features in place and in proper working order. If maintenance or servicing requires the removal of a guard or safety features, be sure to replace the guards or safety feature before resuming operation of the compressor.



**3. ALWAYS WEAR EYE PROTECTION**

Always wear safety goggles or equivalent eye protection. Compressed air must never be aimed at anyone or any part of the body. Be sure to wear protective gear including the sound-proofing and protective garment, crash cap and safety footwear suited for the given working environment.

**4. PROTECT YOURSELF AGAINST ELECTRIC SHOCK**

Prevent body contact with grounded surfaces such as pipes, radiators, ranges and refrigeration enclosures. Never operate the compressor in damp or wet locations.

**5. DISCONNECT THE COMPRESSOR**

Always disconnect the compressor from the power plug and remove the compressed air from the air tank before servicing, inspecting, maintaining, cleaning, replacing or checking any parts.

**6. AVOID UNINTENTIONAL STARTING**

Do not carry the compressor while it is connected to its power source or when the air tank is filled with compressed air. Be sure the power switch in the "OFF" position before

connecting the compressor to its power source.

**7. STORE COMPRESSOR PROPERLY**

When not in use, the compressor should be stored in dry place. Keep out of reach of children. Lock-out the storage area.

**8. KEEP WORK AREA CLEAN AND WELL LIT**

Keep work area clean and well lit. Cluttered or dark areas invite accidents.

**9. KEEP CHILDREN AWAY**

Do not let visitors contact compressor extension cord. All visitors should be kept safely away from work area. Keep out of reach of children.

**10. NEVER USE THE MACHINE IN ANY UNSTABLE PLACE**

Never use it in a place where it could move or fall of itself. Be sure to install the compressor on a flat floor, with leg rubber underneath it; the allowable tilt angle of the floor is up to 10 degrees. If the installation floor is tilted and slippery, ensure that the compressor does not move during operation. Do not use it on a shelf or stand where it may fall or tumble.

**11. DRESS PROPERLY**

Do not wear loose clothing or jewelry. They can be caught in moving parts. Wear protective hair covering to contain long hair.

**12. DO NOT ABUSE POWER CORD**

Never yank it to disconnect from receptacle. Keep power cord from heat, oil and sharp edges.

**13. MAINTAIN COMPRESSOR WITH CARE**

Inspect cords periodically and if damaged, have repaired by authorized service facility.

**14. USE A SAFE EXTENSION CORD**

In order to prevent an electric shock, use a 3-core extension cord with a 3-pole earthing plug and a 3-core earthing plug socket. Make sure that the extension cord is in the good working condition. If the cord is damaged, replace or repair it. The cord should have a sufficient capacity for the current running to the product. The cord of an insufficient capacity will cause a voltage drop or an electric power loss, resulting in overheating. The following table shows the cord size used depending on the cord length.

**Tab.1 SECTION VALID FOR A MAX LENGTH OF 50' (15m)**

| COMPRESSOR      | HP | kW  | VOLTAGE   | MINIMUM GAUGE                |
|-----------------|----|-----|-----------|------------------------------|
| AKHL1320E (USA) | 2  | 1.5 | a.c. 115V | #12<br>(American Wire Gauge) |

**⚠ WARNING**

Avoid electrical shock hazard. Never use this compressor with a damaged or frayed electrical cord or extension cord. Inspect all electrical cords regularly. Never use in near water or in any environment where electric shock is possible.

**15. STAY ALERT**

Watch what you are doing. Use common sense. Do not operate compressor when you are tired. Compressor should never be used by you if you are under the influence of alcohol, drugs or medication that makes you drowsy.

**16. CHECK DAMAGED PARTS AND AIR LEAK**

Before further use of the compressor, a guard or other part which is damaged should be carefully checked to determine that it will operate properly and perform its intended function. Check for alignment of moving parts, binding of moving parts, breakage of parts, mounting, air leak, and any other conditions that may affected its operation.

A guard or other part that is damaged should be properly repaired or replaced by an authorized service facility unless otherwise indicated elsewhere in this Instruction Manual. Have defective pressure controllers replaced by authorized service facility. Do not use compressor if switch does not turn it on and off.

**17. OPERATE COMPRESSOR CORRECTLY**

Operate the compressor according to the instructions provided herein. Never allow the compressor to be operated by children, individuals unfamiliar with its operation or unauthorized personal.

**18. KEEP ALL SCREWS, BOLTS AND COVERS TIGHTLY IN PLACE**

Keep all screws, bolts, and plates tightly mounted. Check their conditions periodically.

**19. KEEP HANDLES DRY, CLEAN AND FREE FROM OIL AND GREASE**

Slippery handles do not allow for safe handling of the compressor in unexpected situations.

**20. KEEP MOTOR AIR VENT CLEAN**

The motor air vent must be kept clean so that air can freely flow at all times. Check for dust build-up frequently.

**21. OPERATE COMPRESSOR AT THE RATED VOLTAGE**

Operate the compressor at voltages specified on their nameplates. If using the compressor at a higher voltage than the rated voltage, it will result in abnormally fast motor revolution and may damage the unit and burn out the motor.

**22. NEVER USE A COMPRESSOR WHICH IS DEFECTIVE OR OPERATING ABNORMALLY**

If the compressor appears to be operating unusually, "SERVICE REQUIRED" LED is lit up, making strange noises, or otherwise appears defective, stop using it immediately and arrange for repairs by an authorized service facility.

**23. DO NOT WIPE PLASTIC PARTS WITH SOLVENT**

Solvent such as gasoline, thinner, benzene, carbon tetrachloride, and alcohol may damage and crack plastic parts. Do not wipe them with such solvents. Wipe plastic parts with a soft cloth lightly dampened with mild detergent and dry thoroughly.

**24. USE ONLY GENUINE REPLACEMENT PARTS**

Replacement parts not original may void your warranty and can lead to malfunction and resulting injuries. Genuine parts are available from your dealer.

**25. DO NOT MODIFY THE COMPRESSOR**  
Do not modify the compressor. Always contact the authorized service facility for any repairs. Unauthorized modification may not only impair the compressor performance but may also result in accident or injury to repair personnel who do not have the required knowledge and technical expertise to perform the repair operations correctly.

**26. TURN OFF THE SWITCH WHEN THE COMPRESSOR IS NOT USED**  
When the compressor is not used, turn the switch OFF, disconnect the plug from the power source and open the drain cock to discharge the compressed air from the air tank.



**27. NEVER TOUCH THE SURFACE OF THE HIGH-TEMPERATURE SECTION**  
In order to prevent a burn, do not touch the piping, head, cylinder, motor, tank, inverter case and other metal parts.

**28. DO NOT DIRECT AIR STREAM AT BODY**  
Risk of injury, do not direct compressed air at persons or animals.

**29. DRAIN TANK**  
Drain should be carried out daily with the tank level.

**30. DO NOT STOP COMPRESSOR BY PULLING OUT THE PLUG**  
Use the "POWER" switch.

**31. WHENEVER USING THE HIGH PRESSURE SIDE OF THE MAX POWERLITE COMPRESSOR, THE GENUINE PARTS FOR THE MAX POWERLITE TOOLS, POWERLITE HOSE MUST BE USED.**

**32. NEVER USE A TRANSFORMER FOR THE POWER SUPPLY OF THIS COMPRESSOR. USING A TRANSFORMER TO INCREASE THE VOLTAGE WILL CAUSE A FAILURE OR BURNOUT. (IF A TRANSFORMER IS USED, OPERATION OF THE MACHINE WILL STOP.)**

**33. NEVER CONNECT THE COMPRESSOR TO AN ENGINE GENERATOR OR DIRECT-CURRENT POWER SUPPLY**  
The compressor will break or be damaged from burning.

**34. THIS COMPRESSOR IS FOR INDOOR USE. DO NOT INSTALL THE COMPRESSOR IN ANY PLACE EXPOSED TO RAIN OR SPLASHED WATER, HIGH-HUMIDITY PLACE OR HIGH-TEMPERATURE PLACE**  
If used in the wet condition, it could produce an electric shock or be short-circuited, resulting in ignition. Use it under the environmental conditions provided by its specifications. Also, do not store or use in cold environments.

**35. DO NOT OPERATE THE TOOL NEAR A FLAMMABLE SUBSTANCE**  
Never operate the tool near a flammable substance (e.g., thinner, gasoline, etc.). Volatile fumes from these substances could be drawn into the compressor and compressed together with the air and this could result in an explosion.

**36. NEVER USE THE TOOL IN AN EXPLOSIVE ATMOSPHERE**  
Sparks from the tool may ignite atmospheric gases, dust or other combustible materials.

**37. BE SURE TO EARTH THE COMPRESSOR**  
Earth the compressor to prevent a worker from getting an electric shock. It comes with a 3-pole cord and a 3-pole earthing plug so that it can be connected to an appropriate earthing plug socket. A green-and-yellow striped wire is an earthing conductor. Never connect it to other charged terminals.

**38. CARRY THE COMPRESSOR AND TANK IN THE FOLLOWING PROPER MANNERS**

- AKHL1320E: Hold the compressor grips with both hands.



- With the optional AKTH15 air tank: Carry the compressor by having two people hold each side of the compressor grips.

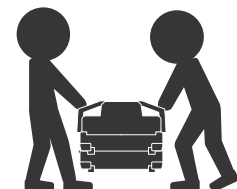

Do not turn the compressor over or lift it with a hook or rope.

AKTH15: Hold the air tank grips.  
(See Fig.X)



- 39. TAKE CARE TO TRANSPORT THE COMPRESSOR CORRECTLY, DO NOT OVERTURN IT OR LIFT IT WITH HOOKS OR ROPES.
- 40. DO NOT PUT FINGERS IN THE BLEEDER OR CLEARANCES IN THE HOUSING.  
This can result in injury, electric shock or burns.

**41. DO NOT USE ANY ADAPTER PLUGS WITH THE COMPRESSOR**

The compressor is factory-equipped with a specific electric cord and plug for connection to a proper electric power source. Never modify the plug in any way. Do not use any adapter plugs with the compressor.

**42. IF OPERATING THIS COMPRESSOR IN A DAMP LOCATION IS UNAVOIDABLE, USE A GROUND FAULT CIRCUIT INTERRUPTER (GFCI) PROTECTED SUPPLY**

Use of a GFCI reduces the risk of electric shock.

**43. USE THE APPROPRIATE TOOL HOSE BECAUSE THE FOLLOWING PRESSURES MAY BE EMITTED FROM THE AIR CHUCK IN THE EVENT OF MACHINE FAILURE.**

High pressure air chuck: 500 psi (34.5 bar)  
Regular pressure air chuck: 225 psi (15.5 bar )

### 3. SPECIFICATIONS

|                                      |          |   |
|--------------------------------------|----------|---|
| <b>Product No.</b>                   |          | <b>AKHL1320E (USA)</b>                      |
| <b>Dimensions</b>                    | <b>L</b> | 22-1/2" 573mm                               |
|                                      | <b>W</b> | 14" 351mm                                   |
|                                      | <b>H</b> | 13-1/4" 336mm                               |
| <b>Weight</b>                        |          | 38.9lbs                                     |
| <b>Power supply</b>                  |          | a.c.115V±10%<br>60Hz±1% Ø1                  |
| <b>Rated current</b>                 |          | 13A   |
| <b>Tank capacity</b>                 |          | 1.32Gal×2 5.0L×2                            |
| <b>Motor power</b>                   |          | 2HP   |
| <b>Protective earthing</b>           |          | Class I                                     |
| <b>Protective structure</b>          |          | IP20  |
| <b>Working temperature</b>           |          | 32°F to 104°F 0°C to +40°C                  |
| <b>Working humidity</b>              |          | 85%RH or less. No dew condensation.         |
| <b>Height above sea level</b>        |          | 3,281ft. UP to 1000m                        |
| <b>Storage temperature</b>           |          | 14°F to 122°F -10°C to +50°C                |
| <b>Storage humidity</b>              |          | 85%RH or less. No dew condensation.         |
| <b>Pressure switch working range</b> |          | 500 psi OFF: 34.5 bar<br>435 psi ON: 30 bar |
| <b>Fluid</b>                         |          | air   |
| <b>Pollution degree</b>              |          | 2   |

|                                      |   |               |
|--------------------------------------|---|---------------|
| <b>Product No.</b>                   | <b>AKHL1320E (USA) + AKTH15</b>             |               |
| <b>Dimensions</b>                    | <b>L</b>                                    | 22-1/2" 573mm |
|                                      | <b>W</b>                                    | 16-3/4" 425mm |
|                                      | <b>H</b>                                    | 19-1/2" 496mm |
| <b>Weight</b>                        | 58.2lbs                                     |               |
| <b>Power supply</b>                  | a.c.115V±10%<br>60Hz±1% Ø1                  |               |
| <b>Rated current</b>                 | 13A   |               |
| <b>Tank capacity</b>                 | 1.32Gal×5 5.0L×5                            |               |
| <b>Motor power</b>                   | 2HP   |               |
| <b>Protective earthing</b>           | Class I                                     |               |
| <b>Protective structure</b>          | IP20  |               |
| <b>Working temperature</b>           | 32°F to 104°F 0°C to +40°C                  |               |
| <b>Working humidity</b>              | 85%RH or less. No dew condensation.         |               |
| <b>Height above sea level</b>        | 3,281ft. UP to 1000m                        |               |
| <b>Storage temperature</b>           | 14°F to 122°F -10°C to +50°C                |               |
| <b>Storage humidity</b>              | 85%RH or less. No dew condensation.         |               |
| <b>Pressure switch working range</b> | 500 psi OFF: 34.5 bar<br>435 psi ON: 30 bar |               |
| <b>Fluid</b>                         | air   |               |
| <b>Pollution degree</b>              | 2   |               |

## 4. INSTRUCTIONS FOR OPERATION

Unpack the compressor and check for any deficiency, damage caused during transportation and loose bolts and screws.

### **⚠WARNING**

#### **READ SECTION TITLED " SAFETY INSTRUCTIONS "**

#### **WEAR SAFETY GLASSES OR GOGGLES**

Danger to the eyes always exists due to the possibility of dust being blown up by the exhausted air or of a fastener flying up to the improper handling of the tool. For these reasons, safety glasses or goggles shall always be worn when operating the tool. The employer and/or user must ensure that proper eye protection is worn. Eye protection equipment must conform to the requirements of Council Directive 89/686/EEC of 21 DEC. 1989 (the American National Standards Institute. ANSI Z87.1) and provide both frontal and side protection.

**NOTE:** Non-side shielded spectacles and face shields alone do not provide adequate protection.

**NOTE:** The information contained in this Instruction Manual is designed to assist you in the safe operation and maintenance of the compressor.

Some illustrations in this Instruction Manual may show details or attachments that differ from those on your own compressor.

### 1. GROUNDING INSTRUCTIONS

#### 1. THIS PRODUCT MUST BE GROUNDED

In the event of an electrical short circuit, grounding reduces the risk of electric shock by providing an escape wire for the electric current. This product is equipped with a cord having a grounding wire with an appropriate grounding plug. The plug must be plugged into an outlet that is properly installed and grounded in accordance with all local codes and ordinances.

#### 2. **⚠WARNING: IMPROPER INSTALLATION OF THE GROUNDING PLUG IS ABLE TO RESULT IN A RISK OF ELECTRIC SHOCK**

When repair or replacement of the cord or plug is required, do not connect the grounding wire to either power terminal. The wire with insulation having an outer surface that is green with or without yellow stripes is the grounding wire.

3. CHECK WITH A QUALIFIED ELECTRICIAN OR SERVICEMAN WHEN THE GROUNDING INSTRUCTIONS ARE NOT COMPLETELY UNDERSTOOD, OR WHEN IN DOUBT AS TO WHETHER THE PRODUCT IS PROPERLY GROUNDED. DO NOT MODIFY THE PLUG PROVIDED; IF IT DOES NOT FIT THE OUTLET, HAVE THE PROPER OUTLET INSTALLED BY A QUALIFIED ELECTRICIAN.

4. USA MODEL IS FOR USE ON A NOMINAL 115-V CIRCUIT. EACH PRODUCT HAS GROUNDING PLUG. ONLY CONNECT THE PRODUCT TO AN OUTLET HAVING THE SAME CONFIGURATION AS THE PLUG. DO NOT USE AN ADAPTER WITH THIS PRODUCT.

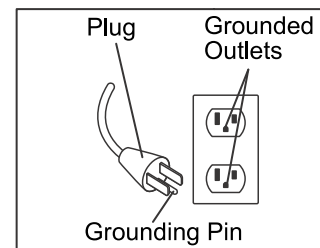

## 2. INSTALLATION

### **⚠WARNING**

1. NEVER USE THE MACHINE IN A PLACE WHERE ANY VOLATILE COMBUSTIBLE SUBSTANCE HAS BEEN STORED. Never use it near gasoline, thinner, gas, paint or adhesive agent, because they could be ignited or blow up.
2. NEVER USE THE MACHINE NEAR THE HEAT OF FIRE OR ANY COMBUSTIBLE SUBSTANCE.
3. DO NOT USE THE MACHINE IN A OVERLY DUSTY(WOODEN CHIPS, ETC.) PLACE.

**4. NEVER USE THE MACHINE IN AN UNSTABLE PLACE.**

Never use it in a place where it could move or fall of itself.

Be sure to install the compressor on a flat floor, with leg rubber underneath it; the allowable tilt angle of the floor is up to 10 degrees. If the installation floor is tilted and slippery, ensure that the compressor does not move during operation. Do not use it on a shelf or a stand where it may fall or tumble.

**5. USE THE MACHINE IN THE APPROPRIATE DIRECTION.**

Install it appropriately.

**6. NEVER INSTALL THE MACHINE IN THE RAIN OR IN A PLACE SPLASHED WITH WATER OR EXPOSED TO HIGH TEMPERATURE.**

Using it in the wet condition could cause an electric shock or a short-circuit, resulting in a fire due to burnout or ignition.

**7. AVOIDING A PLACE EXPOSED TO HIGH TEMPERATURE OR THE DIRECT SUNSHINE, BE SURE TO USE THE MACHINE IN THE WELL-VENTILATED SHADE.**

Using it under high temperature or in the direct sunshine not only deteriorates its durability, but increases the temperature of the main body, causing danger to your safety. Be sure to use it in the well-ventilated shade. The adequate room temperature is 41°F to 86°F (+5°C to +30°C). Maximum is 32°F to 104°F (0°C to +40°C).

**8. NEVER BLOCK A VENTILATION OPENING OR USE THE MACHINE IN A BOX OR A NARROW PLACE(IN A VEHICLE, ETC.)**

Neglect of this may generate abnormal heat, causing a trouble or an accident.

Install the compressor at the distance of 1 m or more from the wall to secure sufficient ventilation and cooling.

**9. DO NOT USE THE COMPRESSOR IN ANY PLACE WHERE THE TEMPERATURE IS 32°F (0°C) OR LESS OR THE AMBIENT TEMPERATURE EXCEEDS 104°F (+40°C).**

### 3. NAME OF PARTS (See Fig.A)

#### Description of Functions of Key Components

|   |  |  |
|---|--|--|
| ① | <b>Power switch</b>  | Turns on or off the power supply   |
| ② | <b>Pressure-Reduction valve adjustment handle (HIGH) (Orange cap)</b>    | Intended for exclusive use with the <i>PowerLite</i> tool. It adjusts the operating pressure of the <i>PowerLite</i> tool.   |
| ③ | <b>Pressure-Reduction valve adjustment handle (REGULAR) (Yellow cap)</b> | Adjusts the pressure supplied to the regular pressure nailers and pneumatic tools (operating air pressure 120psi (8.3 bar) maximum).   |
| ④ | <b>Pressure gauge in the tank</b>  | Indicates pressure in the tank. The pressure increases up to 500psi (34.5 bar).  |
| ⑤ | <b>Pressure gauge (HIGH)</b>   | It indicates the set pressure on the pressure-reduction valves (HIGH). (335psi (24.5 bar) maximum)   |
| ⑥ | <b>Pressure gauge (REGULAR)</b>  | It indicates the set pressure on the pressure-reduction valves (REGULAR). (120psi (8.3 bar) maximum)   |
| ⑦ | <b>High pressure air chuck (for MAX <i>PowerLite</i> tools)</b>          | It connects the MAX <i>PowerLite</i> air hose for the <i>PowerLite</i> tools.  |
| ⑧ | <b>Regular pressure air chuck (for regular pressure tools)</b>           | It connects the air hose for the regular pressure nailers.   |
| ⑨ | <b>Drain cock</b>  | It drains compressed air and water, Drain once when the work is finished or more a day.  |
| ⑩ | <b>Power plug</b>  | It is usable with a triode ground outlet.  |
| ⑪ | <b>Power cord</b>  |  |
| ⑫ | <b>Air tank</b>  |  |
| ⑬ | <b>Rubber foot</b>   |  |
| ⑭ | <b>Corner protector</b>  |  |
| ⑮ | <b>Control panel</b>   | It allows switching the mode between Normal and Quiet. (See Fig.B) For details of the LEDs and switches on the Control panel, see "Control Panel" on page 17.<br><ul style="list-style-type: none"> <li>• <b>Current consumption is reduced in the operation in Quiet mode.</b></li> </ul> |
| ⑯ | <b>Grip for two-handed carry</b>   |  |
| ⑰ | <b>Air chuck 44K</b>   | It connects the flexible pipe M-5 of lower three tanks.  |
| ⑱ | <b>Flexible pipe M-5</b>   | It connects the upper two tanks and the lower three tanks.   |
| ⑲ | <b>Stop plug</b>   | It seals the part to attach the air chuck 44K.   |



## **Control Panel (See Fig.B)**

### **⑳ POWER LED**

### **㉑ TEMPERATURE OR ELECTRICAL PROBLEM LED**

See the buzzer types in Chapter 7. (See page 21)

### **㉒ SERVICE REQUIRED LED**

If it is lit up, it is due to a failure on the inverter or motor. Send the machine to your dealer or authorized service facility to have their checkup or repair. (See page 21)

### **㉓ MAINTENANCE LED**

If it is lit up, send the machine to your dealer or an authorized service facility for inspection. (See page 23)

### **㉔ QUIET MODE SWITCH**

This machine also offers a power-saving operation Quiet mode that you can select when you want to suppress the noises accompanying the operation, or when tripping of the circuit breaker is anticipated during continuous operation. Press the Quiet mode switch to turn on this mode.

- A buzzer sounds with a beep and the LED lights up when the operation switching takes place.
- The switching is available independent of whether the compressor is in operation or stopped.
- Even when the circuit breaker tripped or you have disconnected the power plug from the outlet during operation, status of the last operation is stored in memory.
- Even when the Quiet mode switch is pressed in a low temperature environment, the compressor continues running in the Normal mode for a while. After the compressor warms up sufficiently, it shifts to quiet mode.

## 4. MACHINE OPERATING PROCEDURE

### Inspection and checkup prior to operation

#### **⚠WARNING**

- Prior to use, check the bolts and nuts for loosening and the parts for missing one.
  - Use the outlet of the building installation with a proper protection for the power supply of this compressor. Failure to use a proper protection for the power supply, it may cause electric shock and damage to the compressor. Allowable source voltage range is  $\pm 10\%$ .  
USA: a.c.115V/15A
  - Diameter and length of the extension cord or drum cord used must be the following, respectively. And the cord must be fully drawn out when used.  
USA: Diameter AWG12 minimum / Length 50ft. maximum
  - Make sure the machine is installed in the right direction when using it.
- \* Use the machine in compliance with the instructions provided in "SAFETY INSTRUCTIONS" on page 8.
- \* Pressure values in the description do not include the error in reading the pressure gauge.

1. After turning off the machine power switch, connect the power plug to the outlet.
2. (Fig.C,D) Turn the power switch on while maintaining the drain cock fully open. The buzzer sounds with a beep at the same time.
  - For buzzer sounding patterns, see page 21.
3. (Fig.D) Make sure that the motor starts to run and the air is leaking from the drain cock when the drain cock is open.
4. (Fig.E) Close the drain cock and make sure no air is leaking from the cock.

5. Turn the adjustment handle (in 2 locations) of the pressure-reduction valve fully clockwise until you cannot move it anymore and make sure that the above operation moves the pressure gauge pointer (Fig.F) at both locations.

#### **⚠CAUTION**

- As the pressure in the air tank increases due to the pressure characteristic of the pressure-reduction valve, the pressure can vary from the set supply pressure by as much as 44psi (3 bar).  
Turn the pressure-reduction valve's adjustment handle counterclockwise once to reduce the pressure and then proceed to the adjustment while increasing the pressure by turning the adjusting hand clockwise.
6. Make sure that the compression operation is automatically stopped in the following time.
    - 1320E approx. 6 minutes
    - 1320E+AKTH15 approx. 12 minutes.Except when the power-saving operation in Quiet mode is turned on, auxiliary tank is connected or voltage drop occurred, since these extends the operating hours.
  7. Wait for 5 minutes after the operation is stopped to confirm that there are no abnormal noises or air leakages and that the compressor does not restart.
  8. (Fig.D) Discharge the compressed air by opening the drain cock somewhat. Make sure that the operation is resumed due to a decrease in the pressure.
  9. (Fig.E,G) Close the drain cock and turn the power off while the compression operation is turned on to make sure that these actions stop the machine from operating.
  10. (Fig.H) Turn the adjustment handle (in 2 locations) of the pressure-reduction valve counterclockwise to make sure that this turning moves the pressure gauge pointer downward at both locations. (You may hear sounds due to air leaking but it does not mean there is a failure.)

**11. (Fig.D) Open the drain cock to discharge all the compressed air and water in the air tank.**

If you found any abnormalities in the check-up or inspection prior to the operation, send the machine to your dealer or authorized service facility for inspection or repair.

## Operating Procedure

Before operating the machine, be sure to carry out the "Inspection and checkup prior to operation" described on page 18.

- 1. Fully open the drain cock and turn the power switch on. The buzzer will sound with a beep at the same time.**
  - For buzzer sounding patterns, see page 21.  
After the operation has started, close the drain cock tight to increase the pressure.
- 2. (Fig.I) After confirming the operation has stopped due to the increased pressure, turn the adjustment handle of the pressure-reduction valve to adjust the operating pressure of the nailer and pneumatic tool to the appropriate level. When adjusting the pressure, turn the pressure-reduction valve's adjustment handle counterclockwise to set the pressure at a level lower than the appropriate value by 2 bars once. Then proceed to the adjustment while increasing the pressure by turning the handle clockwise.**
  - Make sure to start the adjustment at a level lower than the appropriate pressure and continue the adjustment while increasing the pressure from that level upward. If you start the adjustment from a level higher than the appropriate value, an error results between the pressure gauge value and actually used pressure. (Due to Characteristics of pressure-reduction valve respectively)
  - 2 pressure-reduction valves provided on this machine allow you to connect MAX *PowerLite* and the general-purpose nailer or pneumatic tool.  
<Pressure-reduction valve H> Allows connection and use of MAX PowerLite tools (of operating pressure of 355psi (24.5 bars) maximum)  
<Pressure-reduction valve L> Allows connection and use of the general-purpose nailers or pneumatic tools (of operating pressure of 120psi (8.3 bars) maximum)

## WARNING

- **You must observe the specified operating air pressure for the nailers and pneumatic tools.**  
Using a nailer or pneumatic tool without adjusting the supply pressure with the reduction valve can seriously degrade their performance, induce their premature aging or damage them.
  - Using a nailer or pneumatic tool at an inappropriate pressure level (at an unnecessary high pressure) increases their air consumption, potentially degrading their capability in continuous work. Be sure to use them at the appropriate pressure.
- 3. (Fig.J) After you have finished with the adjustment of supply pressure, you can start the operation by connecting the air hose to the air outlet (air chuck).**
  - 4. Connect the high pressure hose to the high pressure air hose for MAX PowerLite tools to the high pressure air chuck on the H side of the pressure-reduction valve.**  
Connect the air hose for the general-purpose nailer to the air chuck on the L side of the pressure-reduction valve.

## WARNING

- **Before connecting the air hose to this compressor, make sure that the air hose and hose fixture are firmly secured.**

## 5. PROTECTIVE DEVICE

If internal heat builds up during operation due to clogging of the airflow orifice, if the machine is used in a highly heated environment or if an abnormality occurs inside the machine, the thermal protector for preventing burnout may be activated to stop the motor operation. The buzzer will sound in this case. In such a case:

1. **(Fig.G,K) Turn the power switch off and disconnect the power plug from the outlet.**
  - For buzzer sounding patterns, see page 21.
2. **(Fig.C,L) Connect the power plug to the outlet and turn the power switch on to resume the operation.**
  - If the motor has sufficiently cooled down, the resumed operation may activate the protective device soon after. In other cases, the operation may not resume when you turned the power switch on. In such a case, wait for about 30 minutes for the motor to cool down before restarting the machine.

### **WARNING**

3. **If the protective device was activated when there were no apparent problems existing in the operating environment, stop using the compressor and send it to your dealer or authorized service facility for checkups or repairs.**

## 6. ABNORMALITIES DURING OPERATION

### **WARNING**

- **If you detect any abnormalities, do not operate the compressor.**

If you encounter any of the following abnormal phenomena, turn off the power switch immediately, disconnect the power plug from the outlet and send the machine to your dealer or authorized service facility for checkups or repairs.



1. **The following problems may occur even when there are no problems with the power supply or wiring: (See "PROTECTIVE DEVICE" on page 20.)**
  - Turning on the power switch does not start up the machine.
  - Motor moan is generated.
2. **Abnormal sounds are generated during operation. (See "AUTOMATIC ADJUSTMENT OF OPERATING POWER" (INVERTER CONTROL) on page 22.)**
3. **The safety valve instead of the pressure sensor is activated, allowing the compressed air to blow out.**
4. **Air leakage happens.**
5. **Pressure does not increase. (See page 22)**
6. **An electrical shock-like pain is felt when touched the metal part.**
7. **Other abnormalities than the above that is recognized during operation.**

## 7. BUZZER TYPES

### In normal operation

| Buzzer sounds                    | Symptom                         | Actions taken |
|----------------------------------|---------------------------------|---------------|
| A one-time short beep sound (Pi) | At powering on                  | -             |
|                                  | When the quiet mode is switched | -             |

### In cases of abnormal operation

|   | LED LAMP  | Buzzer sounds                         | Cause   | Actions taken  |
|---|---|---------------------------------------|---|--|
| ① | <br>Short blinking | None                                  | Power supply is over 138V or below 90V  | Examine the state of the power supply (See page 22)  |
|   |   | Short beep sounds (Pi, Pi, Pi, ...)   | Power supply is excessively high or low voltage   |  |
| ② | <br>Long blinking  | Long beep sounds (Pii, Pii, Pii, ...) | <ul style="list-style-type: none"> <li>• Motor temperature went abnormally high</li> <li>• Temperature in the control circuit has built up to an abnormally high level</li> </ul> | <ul style="list-style-type: none"> <li>• Do not use the compressor in extremely high temperatures.</li> <li>• Examine the state of the power supply (See page 22)</li> <li>• Never block a ventilation opening or use the machine in a box or a narrow place (in a vehicle, etc.)</li> </ul> |
| ③ | <br>Lightning    | Beeping sounds (Piiiiiii.....)        | <ul style="list-style-type: none"> <li>• Motor does not run</li> <li>• Failure in the control circuit</li> </ul>  | It is due to a failure on the inverter or motor. Send the machine to your dealer or authorized service facility to have their checkup or repair.   |

## 8. HOW TO INSTALL OPTIONAL 1320E TANK

### **WARNING**

- This tank is for AKHL1320E only.
- Do not connect to anything other than AKHL1320E.
- Please read the AKHL1320E instructions carefully before use.

With AKHL1320E, you can add the optional AKTH15 air tank for 1320E. If more air is required, use the following steps to install the optional air tank.

### Installation

1. (Fig.G,K) Turn off the power switch of the compressor and unplug the power cord from the electrical outlet.
2. (Fig.D) Open the drain cock and drain compressed air from the tank.
3. (Fig.O,P) Remove the stop plug from the compressor clockwise and mount by turning the air chuck 44K that comes with the AKTH15 counterclockwise.
4. (Fig.Q) Keep the latch open
5. (Fig.R) Align the compressor and the AKTH15 as shown in the illustration.
6. (Fig.S) Mount the rubber feet of the compressor on the holders of the AKTH15.
7. (Fig.T) Attach and secure the front and rear latches of AKTH15 to the hook of the compressor. Ensure that both of the latches are firmly in place.
8. (Fig.U) Connect the connector of the flexible pipe to the air chuck 44K. When connecting, please press the air plug strongly because the pressing is in two stages.
9. (Fig.L,C) Make sure that the front and rear latches, and the air chuck 44K are not loose, plug the compressor's power cord in the electric outlet and turn the compressor's power switch on.
10. Before operating the machine, be sure to carry out the "Inspection and checkup prior to operation" described on page 18.

### Removal

1. (Fig.G,K) Turn off the power switch of the compressor and unplug the power cord from the electrical outlet.

2. (Fig.D) Open the drain cock of the compressor and optional air tank and drain compressed air from the tank.
3. (Fig.V) Disconnect the connector of the flexible pipe from the air chuck 44K. Turn the sleeve of the air chuck 44K counterclockwise, and push the sleeve to remove the air plug.
4. (Fig.W) Push in the locks on the front and rear latches of the AKTH15, and remove them from the hooks.
5. (Fig.R) Lift and remove from AKTH15.
6. (Fig.L,C) Plug the compressor's power cord in the electric outlet and turn the compressor's power switch on.
7. Before operating the machine, be sure to carry out the "Inspection and checkup prior to operation" described on page 18.

## 9. AUTOMATIC ADJUSTMENT OF OPERATING POWER (INVERTER CONTROL)

Microcomputer-based inverter control is enabled on this machine in order to ensure the maximum utilization of the discharging performance. Adjustment of the operating power is automatically continued until the pressure in the machine tank reaches the maximum level. Operating sounds may change when the operating power is switched, but you do not have to worry about them. Changes in the sounds are not due to a failure.

- The pressure level at which the output change-over is activated varies depending on the capacity of the main power supply, type of extension cord used and parallel use of other electric equipment. If the voltage is excessively low, extra time will be required for the filling.
- If the fill time is longer than usual or when the pressure does not increase, change the current connection to the power supply (reconnect to the main power supply) or stop the joint use of the power supply with a power tool.
- When capacity of the main power is excessively low, or when it is jointly used with another power tool, a radical voltage drop results, may result in startup failure.
- The circuit breaker of the power supply may be activated if the total current consumption resulting from the parallel use with another power tool exceeds the current capacity of the circuit breaker.

If the circuit breaker trips, the power supply switch of the compressor moves to the OFF position.

Stop using other power tools on the same power source as the compressor. Then, after waiting for 30 seconds or more, turn the switch ON.

## 10. IN ORDER TO MAINTAIN PERFORMANCE

### 1. Drain water from the machine.

After the work is finished, open the drain cock gradually to drain the compressed air and water in the air tank until the pressure gauge in the tank points to 0.

- **Not draining the water will result in the inside of the air tank becoming moldy, potentially leading to a failure.**

### 2. (Fig.B<sup>㉓</sup>) The Maintenance LED lights up.

Operating hours of this machine are measured with a microcomputer. The MAINTENANCE LED lights up as the machine operating hours reaches 1000 hours. If the Maintenance LED lights up, be sure send the machine to your dealer or an authorized service facility for inspection.

### 3. Implement the machine inspection on a regular basis.

The User is requested to implement cleaning and inspection of the machine in order to maintain its performance. Please do not hesitate to let your dealer or authorized service facility inspect your machine more than once a year.

### 4. Handle this machine carefully.

Dropping the machine inadvertently, bumping it against solid objects or hitting it can cause deformation, cracks or damage to the machine. The User is advised not to invite an accident by dropping, bumping or hitting the machine.

### 5. Never sit or place an object on the top of the machine.

Neglect of this could cause a trouble or break it.

### 6. Inspect the machine every time you use it.

Check and inspect the machine in conformance with the procedure described in the SAFETY INSTRUCTIONS provided on page 8 and after.

## 7. ABOUT PRODUCTION YEAR AND MONTH

This product bears production number in the RATING LABEL. The three digits of the number from left indicates the production year and month.

(Example)

24408035H

↑  
Year 2024

Month April

|   |           |
|---|-----------|
| 1 | January   |
| 2 | February  |
| 3 | March     |
| 4 | April     |
| 5 | May       |
| 6 | June      |
| 7 | July      |
| 8 | August    |
| 9 | September |
| A | October   |
| B | November  |
| C | December  |