



Click Here To View  
Item at

[www.GapPower.com](http://www.GapPower.com)

*Sales • Rentals  
Parts & Service*

# TRAILER-MOUNTED BOOMS



**3522 A - 3632 T**  
**4527 A - 5533 A**



## Access on the move:

- Hydraulic outriggers and automatic leveling allow operation in under 30 seconds
- Superior combination of industry leading capacity and outreach
- Can be towed by a standard half-ton pickup truck - No commercial driver's license needed

## Exceptional productivity

- Air / water lines and 110V GFI protected power to the platform

### 3632T

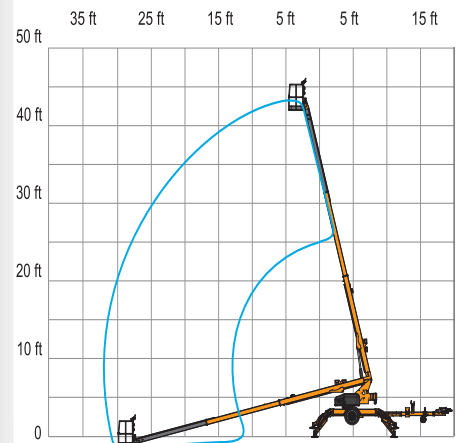

### 3522A 4527A 5533A

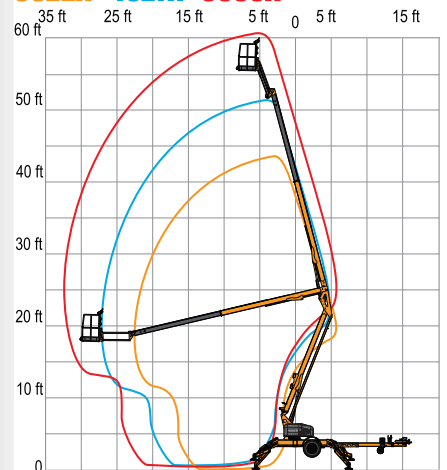

**Haulotte**   
GROUP

More than lifting

[www.haulotte-usa.com](http://www.haulotte-usa.com)



# 3522 A - 3632 T - 4527 A - 5533 A



## TRAILER-MOUNTED BOOMS

### TECHNICAL DATA

	3522 A	3632 T	4527 A	5533 A
Working height	41 ft 9 in	43 ft 6 in	51 ft	61 ft 3 in
Platform height	35 ft 9 in	37 ft 6 in	45 ft	55 ft 3 in
Horizontal outreach (from centerline)	22 ft 6 in	32 ft	27 ft	33 ft 5 in
Horizontal outreach (from edge of footpad)	17 ft 5 in	27 ft	21 ft	27 ft 4 in
Up and over height	19 ft	N/A	20 ft 9 in	23 ft 1 in
Lift capacity	500 lb			
A - Length - stowed	16 ft 3 in	21 ft 11 in	19 ft 6 in	22 ft 11 in
B - Width stowed	5 ft 6 in		5 ft 7 in	
C - Height stowed	6 ft 5 in		6 ft 6 in	
D x E - Platform size	4 ft x 2 ft 6 in			
F x G - Outrigger footprint	11 ft 1 in x 9 ft 11 in	12 ft 4 in x 11 ft 4 in		12 ft 11 in x 12 ft 9 in
Turntable rotation	700° non-continuous			
Jib - length	4 ft 3 in	N/A	4 ft 3 in	
Jib - Vertical motion	150° (+70 / -80)	N/A	150° (+70 / -80)	
Tow speed rating	65 mph			
Gradeability	12.5%			
Leveling capability	12.5°			
Tire size	ST 225/75 R15D			
Power source	4 x 6 V 245 amp-hr			
Tongue weight (no options)	245 lb	200 lb	290 lb	335 lb
Weight (no options)	3,400 lb	4,440 lb	4,200 lb	4,800 lb

### STANDARD EQUIPMENT

- Hydraulic outriggers
- Tilt alarm/sensor
- Hour meter and battery condition indicator
- Automatic leveling system and self-leveling platform
- 110V GFI protected outlet to platform and base
- Easy to use controls
- Air and water line to platform
- Inboard 40 amp charger
- Integrated forklift pockets
- Hydraulic surge brakes

### OPTIONS & ACCESSORIES

- Material lifting hook
- Spare tire and mounting kit
- DC / Gas hybrid
- Platform rotator (manual)
- Flashing beacon
- Flourescent tube caddy
- Combination hitch
- Tool tray

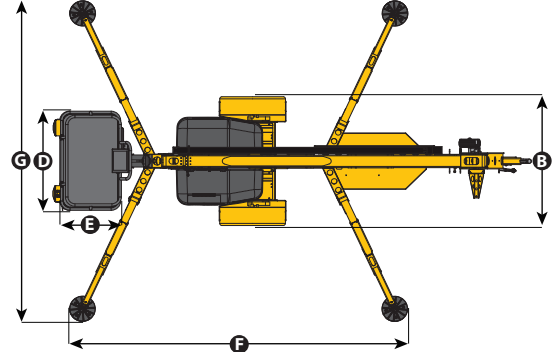
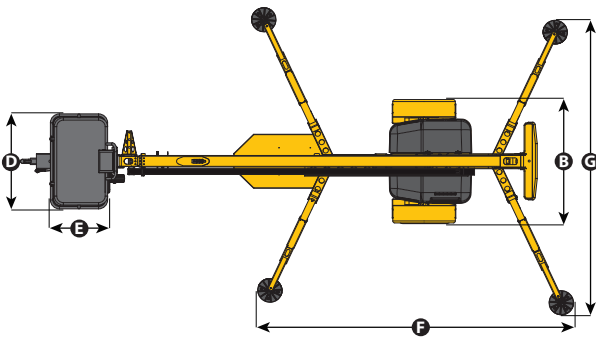
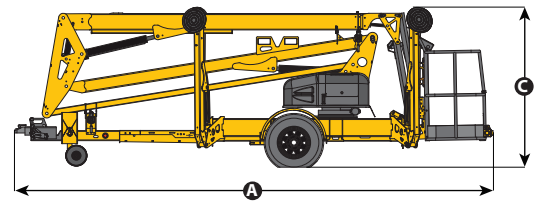
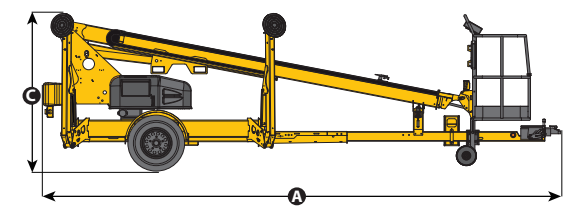

0205-0091 - Non contractual document - We reserve the right to modify the technical characteristics of this document without notice - 1/2013

