

## Table Mitre Saw - F 012 360 100 - 3601

Item	Part Number	Description	Illustration	Price	Quantity	Price Group
1	1 619 PA0 515	Insert	2	\$ 3.55	1	17
2	1 619 PA0 092	Pan head screw	1	\$ 0.65	25	10
3	1 619 PA0 521	Insert	2	\$ 3.55	1	17
4	1 619 PA0 093	Turntable	2	\$ 74.50	1	44
5	1 619 PA0 094	Lever Foot	2	\$ 0.65	4	10
6	1 619 PA0 095	Plain Washer	2	\$ 0.65	4	10
7	1 619 PA0 096	Spring Lock Washer	1	\$ 0.65	11	10
8	1 619 PA0 097	Pan head screw	2	\$ 0.65	4	10
9	1 619 PA0 098	Pan head screw	2	\$ 0.65	2	10
10	1 619 PA0 099	Plate	2	\$ 1.90	1	14
11	1 619 PA0 100	Spring Lock Washer	1	\$ 0.65	33	10
12	1 619 PA0 352	Pan head screw	2	\$ 0.65	4	10
13	1 619 PA0 101	Plate	2	\$ 0.65	1	10
14	1 619 PA0 102	Solder Stick	2	\$ 1.60	1	13
15	1 619 PA0 103	Bolt	1	\$ 1.29	1	12
16	1 619 PA0 104	Flange	1	\$ 1.07	1	11
18	1 619 PA0 106	Flange	1	\$ 1.07	1	11
20	1 619 PA0 108	Key	1	\$ 0.65	4	10
21	1 619 PA0 353	Lever Foot	1	\$ 0.65	1	10
22	1 619 PA0 109	Pan head screw	1	\$ 0.65	7	10
25	1 619 PA0 112	Pan head screw	1	\$ 0.65	4	10
27	1 619 PA0 114	Ring	1	\$ 0.65	1	10
28	1 619 PA0 115	Bearing	1	\$ 0.65	1	10
29	1 619 PA0 116	Ring	1	\$ 0.65	1	10
30	1 619 PA0 117	Pan head screw	1	\$ 0.65	1	10
31	1 619 PA0 119	Spring	1	\$ 0.65	1	10
32	1 619 PA0 120	Pin	1	\$ 0.65	1	10
33	1 619 PA0 121	Case	1	\$ 8.30	1	23
34	1 619 PA0 122	Baffle	1	\$ 0.65	1	10
35	1 619 PA0 123	Nut	1	\$ 0.65	1	10
36	1 619 PA0 124	Spring Lock Washer	1	\$ 0.65	1	10
37	1 619 PA0 125	Pinion	1	\$ 4.10	1	18

Item	Part Number	Description	Illustration	Price	Quantity	Price Group
38	1 619 PA0 354	Bearing	1	\$ 2.42	1	15
39	1 619 PA0 126	Pin	1	\$ 0.65	1	10
40	1 619 PA0 127	Armature	1	\$ 23.05	1	33
41	1 619 PA0 128	Bearing	1	\$ 1.29	1	12
42	1 619 PA0 129	Bearing Sleeve	1	\$ 0.65	1	10
43	1 619 PA0 130	Pan head screw	1	\$ 0.65	2	10
44	1 619 PA0 131	Cover	1	\$ 1.29	1	12
45	1 619 PA0 132	Pan head screw	1	\$ 0.65	4	10
46	1 619 PA0 133	Brush Spring	1	\$ 0.65	2	10
47	1 619 PA0 134	Brush Holder	1	\$ 1.29	2	12
49	1 619 PA0 136	Housing	1	\$ 6.25	1	21
50	1 619 PA0 137	Stator	1	\$ 18.70	1	31
51	1 619 PA0 138	Plain Washer	1	\$ 0.65	19	10
52	1 619 PA0 139	Pan head screw	1	\$ 0.65	2	10
53	1 619 PA0 140	Plug	1	\$ 8.30	1	23
54	1 619 PA0 141	Cable	1	\$ 0.65	1	10
56	1 619 PA0 143	Pan head screw	1	\$ 0.65	7	10
57	1 619 PA0 144	Fastening Clamp	1	\$ 0.65	1	10
63	1 619 PA0 150	Terminal	1	\$ 0.65	1	10
65	1 619 PA0 152	Pan head screw	1	\$ 0.65	1	10
66	1 619 PA0 153	Pan head screw	1	\$ 0.65	1	10
67	1 619 PA0 154	Washer	1	\$ 0.65	1	10
68	1 619 PA0 155	Pan head screw	1	\$ 0.65	1	10
69	1 619 PA0 156	Cover	1	\$ 0.65	1	10
70	1 619 PA0 157	Pawl	1	\$ 1.29	1	12
71	1 619 PA0 158	Pan head screw	1	\$ 0.65	1	10
72	1 619 PA0 159	Guard	1	\$ 1.29	1	12
73	1 619 PA0 160	Pan head screw	1	\$ 0.65	1	10
74	1 619 PA0 161	Spring	1	\$ 0.65	1	10
75	1 619 PA0 162	Knob	1	\$ 0.65	3	10
76	1 619 PA0 163	Indicator	1	\$ 0.65	1	10
77	1 619 PA0 164	Pan head screw	1	\$ 0.65	1	10
78	1 619 PA0 165	Guard	1	\$ 10.60	1	25
79	1 619 PA0 166	Pawl	1	\$ 1.07	1	11
80	1 619 PA0 355	Spring	1	\$ 0.65	1	10
81	1 619 PA0 356	Pin	1	\$ 0.65	1	10
82	1 619 PA0 357	Pawl	1	\$ 1.29	1	12
83	1 619 PA0 358	Pan head screw	1	\$ 0.65	1	10
84	1 619 PA0 359	Nut	1	\$ 0.65	1	10
85	1 619 PA0 167	Control Pressure Port	1	\$ 1.07	1	11
86	1 619 PA0 168	special channel trap	2	\$ 0.65	2	10
87	1 619 PA0 169	Fastening Clamp	2	\$ 0.65	1	10
88	1 619 PA0 170	Holder	2	\$ 11.75	1	26
89	1 619 PA0 171	Pan head screw	2	\$ 0.65	4	10
90	1 619 PA0 172	Rubber Retaining Ring	2	\$ 0.65	4	10
91	1 619 PA0 173	Plate	2	\$ 1.07	2	11
92	1 619 PA0 174	Bearing	2	\$ 8.30	1	23
93	1 619 PA0 175	Bearing	2	\$ 11.75	1	26
95	2 610 032 030	Pan head screw	2	-,-	6	-
97	2 610 032 031	Adjusting Slide	2	-,-	1	-

Item	Part Number	Description	Illustration	Price	Quantity	Price Group
98	1 619 PA0 180	Pan head screw	1	\$ 0.65	2	10
99	1 619 PA0 181	Spring	1	\$ 0.65	1	10
101	2 610 033 423	Pan head screw	2	-,-	2	-
102	1 619 PA0 184	Screw	1	\$ 0.65	1	10
103	2 610 031 799	Bar	2	-,-	1	-
104	1 619 PA0 186	Bar	2	\$ 20.95	1	32
105	1 619 PA0 187	Holder	2	\$ 11.75	1	26
111	1 619 PA0 194	Indicator	2	\$ 0.65	1	10
112	1 619 PA0 195	slide	2	\$ 5.45	1	20
113	1 619 PA0 196	Knob	2	\$ 0.65	1	10
114	1 619 PA0 197	Cover	2	\$ 0.65	1	10
115	1 619 PA0 198	Spring	2	\$ 0.65	1	10
116	1 619 PA0 199	Ball	2	\$ 3.55	1	17
117	1 619 PA0 200	Bit holder	2	\$ 0.65	1	10
118	1 619 PA0 201	Protective fence	2	\$ 13.05	1	27
119	1 619 PA0 202	Guide Pivot	2	\$ 0.65	1	10
120	1 619 PA0 360	Plate	2	\$ 0.65	6	10
121	1 619 PA0 203	Key Holder	2	\$ 0.65	1	10
122	1 619 PA0 204	Mains Key	2	\$ 0.65	1	10
123	1 619 PA0 205	Dust Bag	1	\$ 4.10	1	18
124	2 610 032 033	Nameplate	2	-,-	1	-
125	2 610 033 517	Spring Washer	2	-,-	2	-
126	2 610 033 516	Plain Washer	2	-,-	2	-
127	1 619 PA0 342	Warning Label	2	\$ 1.07	1	11
128	1 619 PA0 343	Warning Label	2	\$ 1.07	1	11
129	1 619 PA0 344	Warning Label	2	\$ 1.07	1	11
130	1 619 PA0 345	Warning Label	2	\$ 1.07	1	11
131	1 619 PA0 599	Warning Label	2	\$ 1.07	1	11
132	1 619 PA0 609	Rubber	2	\$ 0.65	2	10
800	1 619 PA0 348	Clamp	2	\$ 9.35	1	24
804	2 610 032 209	Switch	1	-,-	1	-
826	1 619 PA0 600	Gear	1	\$ 18.70	1	31
848	1 619 PA0 347	Brush	1	\$ 4.10	1	18
855	2 610 032 035	Locking Pin	2	-,-	1	-
858	2 610 032 032	Handle	1	-,-	1	-

Product information Table Mitre Saw - F 012 360 100 - 3601

Product No	F 012 360 100
Description	269,891; Table Mitre Saw
DIN-Text	
ID_Text_Ext	0
Trading_Description	3601
Voltage_1	120 V
ID_Country_Product	USA

Illustration - Type E

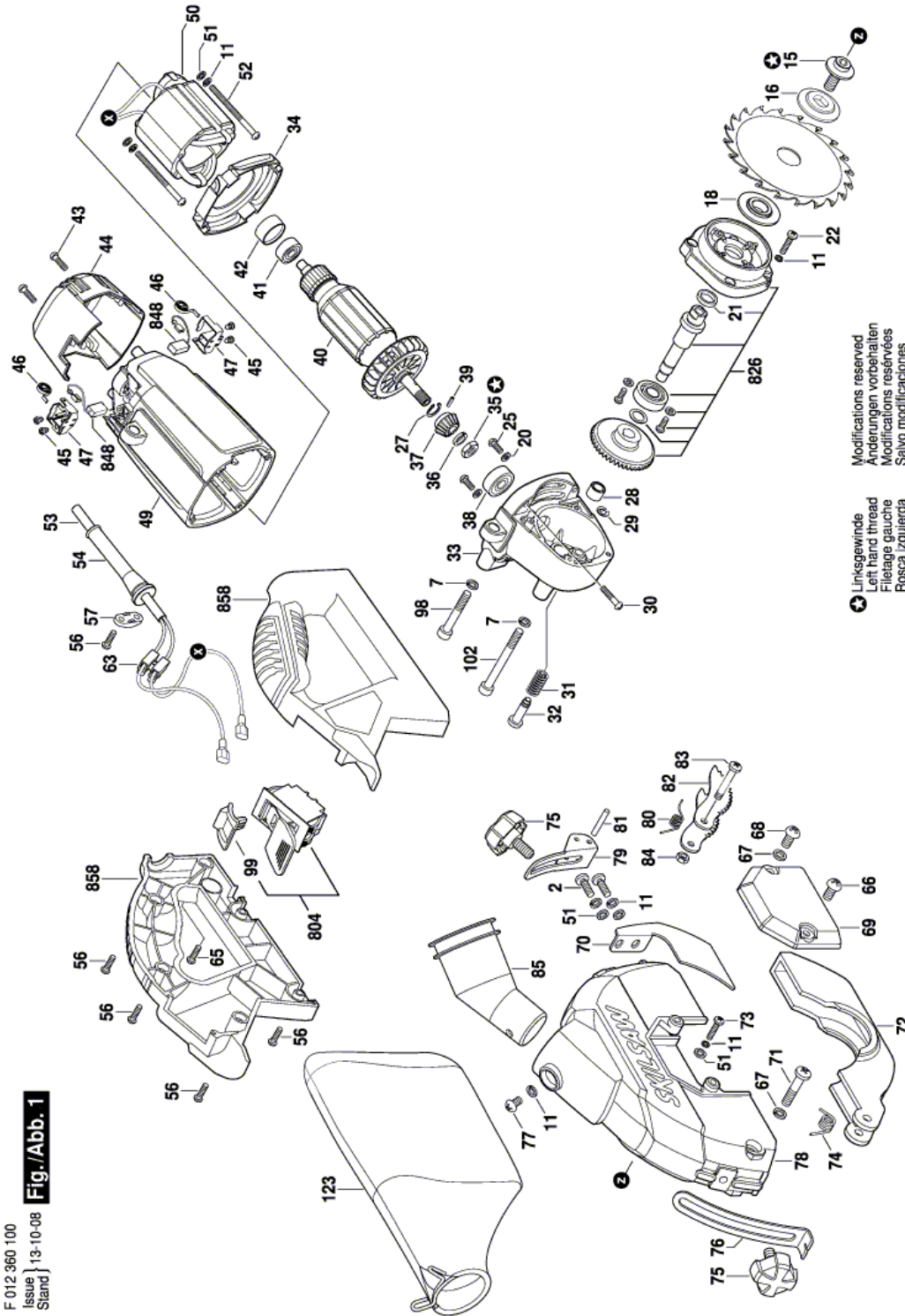

F 012 360 100  
 Issue 13-10-08  
 Stand } **Fig./Abb. 1**

Illustration - Type E

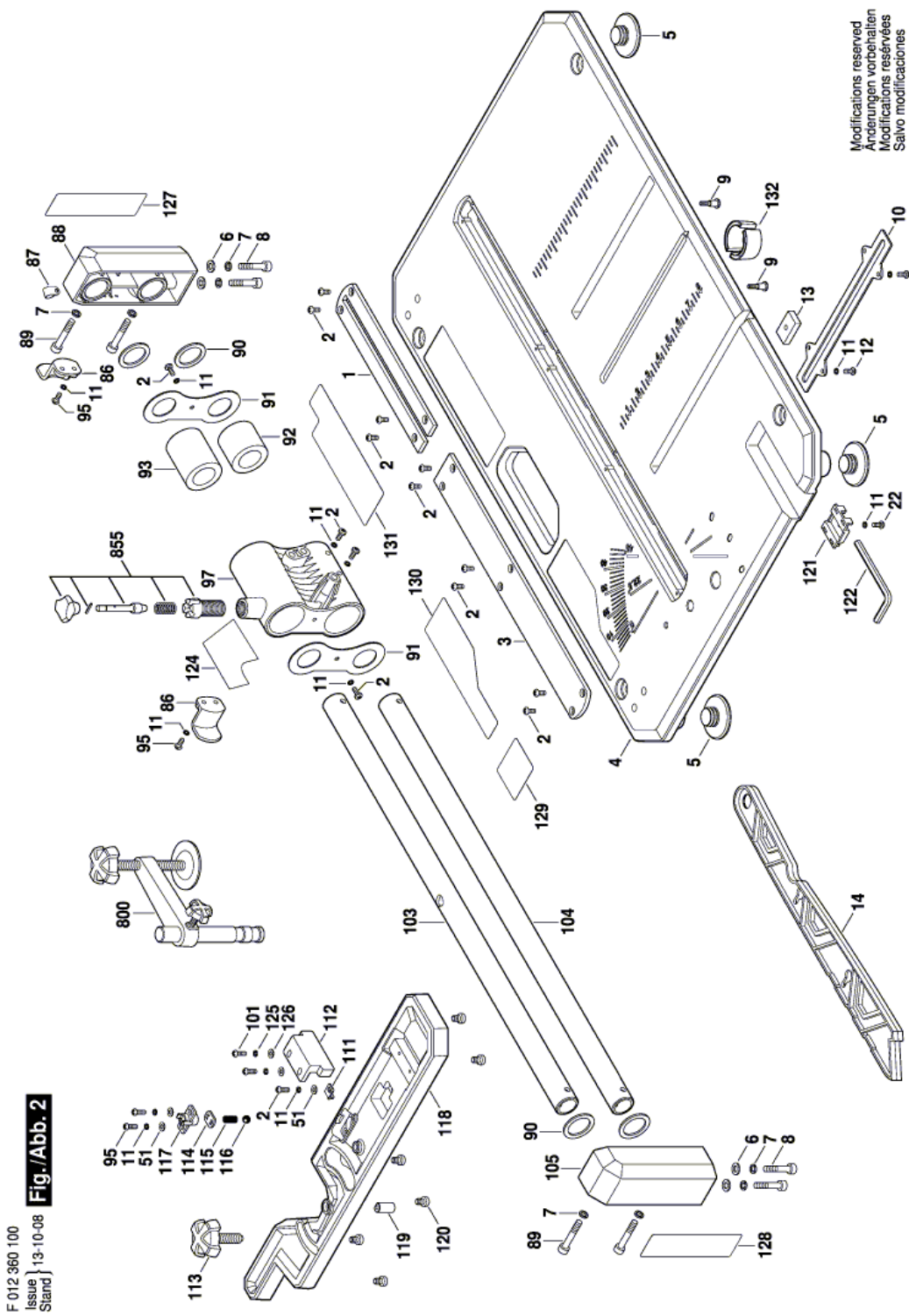

Information subject to change without further notice.