



[Click Here To View](#)  
[Item at](#)

[www.GapPower.com](http://www.GapPower.com)

*Sales • Rentals*  
*Parts & Service*

# MK-660 TILE SAW OWNER'S MANUAL PARTS LIST & OPERATING INSTRUCTIONS

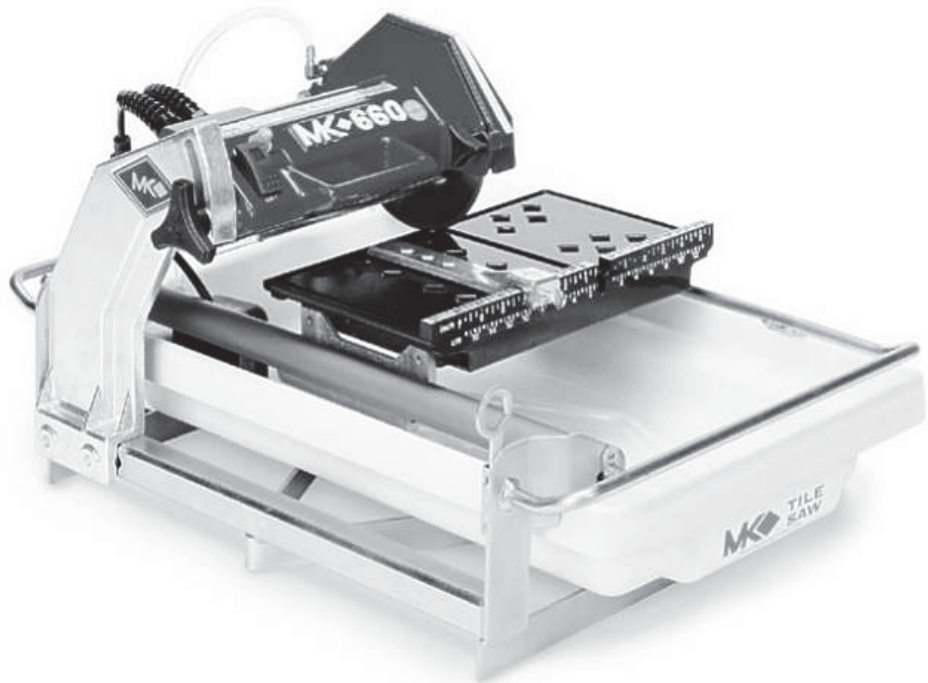

Revision 102	12.2010
Manual Part# 153461	

**Caution:** Read all safety and operating instructions before using this equipment. This parts list **MUST** accompany the equipment at all times.

## INTRODUCTION

Congratulations on your purchase of a MK-660 Saw. We are certain that you will be pleased with your purchase. MK Diamond takes pride in producing the finest construction power tools and diamond blades in the industry.

Operated correctly, your MK-660 Saw should provide you with years of service. In order to help you, we have included this manual. This owners manual contains information necessary to operate and maintain your MK-660 Saw safely and correctly. Please take the time to familiarize yourself with the MK-660 Saw by reading and reviewing this manual.

Read and follow all safety, operating and maintenance instructions.

If you should have questions concerning your MK-660 Saw, please feel free to call our friendly customer service department at: 800 421-5830

Regards,

MK Diamond

### NOTE THIS INFORMATION FOR FUTURE USE:

<b>MODEL NUMBER:</b>	
<b>SERIAL NUMBER:</b>	
<b>PURCHASE PLACE:</b>	
<b>PURCHASE DATE:</b>	

**NOTE:** For your (1) one year warranty to be effective, complete the warranty card (including the Serial Number) and mail it in as soon as possible.

# TABLE OF CONTENTS

## **SAFETY**

Rules for Safe Operation	4-6
California Proposition 65 Message	6
Hazard Symbols	7
Electrical Requirements	8-10
Safety Label Locations	11
Product Specifications	12

## **UNPACKING, TRANSPORT and ASSEMBLY**

Unpacking	13
Contents	13
Transport	14
Stand	14

## **STARTUP, ADJUSTMENT, OPERATION and SHUTDOWN**

Cutting Head Installation	15
Diamond Blade Installation	15-16
Adjustable Cutting Guide Installation	16
Splash Guard Installation	17
Water Pump Installation	17
Pre-Start Inspection	17-18
Connecting the Water Pump	18
Water Pump Setup for Operation	19
Recirculation	19
Setup for Operation	20
Portable Generator	20
Operation (Cutting Straight edges, Diagonal Cutting, 45° Miter Cutting, Off-Angle Cutting)	21-24
Cleanup	25-26

## **MAINTENANCE AND TROUBLESHOOTING**

Maintenance	26-29
Flow adjustment	29
Blade Dressing	30
Diamond Blade Change-Out	31
Troubleshooting	32-34

## **EXPLODED VIEW AND PARTS LIST**

Exploded View & Parts List	36-38
----------------------------	-------

## **ACCESSORIES ORDERING and RETURN INSTRUCTIONS**

Accessories	41
Ordering Information	42
Return Material Policy	42
Packaging Instructions	42
Authorized Service Centers	42

Read and follow all safety, operating and maintenance instructions. Failure to read and follow these instructions could result in injury or death to you or others. Failure to read and follow these instructions could also result in damage and/or reduced equipment life.

## SAFETY MESSAGES

---

A safety message alerts you to potential hazards that could hurt you or others. Each safety message is preceded by a safety alert symbol (  ) and one of three words: **DANGER**, **WARNING**, or **CAUTION**.



**DANGER** You **WILL** be **KILLED** or **SERIOUSLY INJURED** if you do not follow directions.



**WARNING** You **CAN** be **KILLED** or **SERIOUSLY INJURED** if you do not follow directions.



**CAUTION** You **CAN** be **INJURED** if you do not follow directions. It may also be used to alert against unsafe practices.

## DAMAGE PREVENTION AND INFORMATION MESSAGES:

A Damage Prevention Message is to inform the user of important information and/or instructions that could lead to equipment or other property damage if not followed. Information Messages convey information that pertains to the equipment being used. Each message will be preceded by the word **NOTE**, as in the example below.

**NOTE:** Equipment and/or property damage may result if these instructions are not followed.

## GENERAL SAFETY PRECAUTIONS AND HAZARD SYMBOLS

In order to prevent injury, the following safety precautions and symbols should be followed at all times!

## SAFETY PRECAUTIONS

---



**ALWAYS** read this Owner's Manual before operating the machine.



**ALWAYS** keep the Blade Guards in place.



### REMOVE ADJUSTING KEYS AND WRENCHES

Form a habit of checking to see that keys and adjusting wrenches are removed from the power tool before it is turned on.



### KEEP WORK AREA CLEAN

Cluttered work areas and benches invite accidents.



### DO NOT USE IN DANGEROUS PLACES

**DO NOT** use power tools in damp or wet locations nor expose them to rain. Always keep the work area well lit.



### KEEP CHILDREN AWAY

All visitors and children should be kept a safe distance from work area.

**MAKE THE WORKSHOP KID PROOF**

Make the workshop kid proof by using padlocks, master switches or by removing starter keys.

**DO NOT FORCE THE TOOL**

A power tool will do a job better and safer operating at the rate for which it was designed.

**USE THE RIGHT TOOL**

**DO NOT** force a tool or an attachment to do a job that it was not designed to do.

**USE THE PROPER EXTENSION CORD**

If using an extension cord make sure it is in good condition first. When using an extension cord, be sure to use one heavy enough to carry the current your product will draw. An undersized cord will cause a drop in line voltage that will result in a loss of power and overheating. Page 10 shows the correct AWG size to use depending on cord length and nameplate ampere rating. If in doubt, use the next heavier gage. The smaller the gage number, the heavier the cord.

**USE PROPER APPAREL**

**DO NOT** wear loose clothing, gloves, neckties, rings, bracelets, or other jewelry that may be caught in moving parts. Non-slip footwear is recommended. Wear protective hair covering to contain long hair.



**ALWAYS** wear approved eye protection.



**ALWAYS** wear approved respiratory protection.

**SECURE WORK**

Clamps or a vise should be used to hold work whenever practical. Keeping your hands free to operate a power tool is safer.

**DO NOT OVERREACH**

Keep proper footing and balance at all times by not overreaching.

**MAINTAIN TOOLS WITH CARE**

Keep tools clean for the best and safest performance. Always follow maintenance instructions for lubricating and when changing accessories.

**DISCONNECT TOOLS**

Power tools should always be disconnected before servicing or when changing accessories, such as blades, bits, cutters, and the like.



**ALWAYS** place the power ON/OFF switch in the **OFF** position when the saw is not in use.

**USE RECOMMENDED ACCESSORIES**

Consult the Owner's Manual for recommended accessories. Using improper accessories may increase the risk of personal or by-stander injury.

**NEVER STAND ON THE TOOL**

Serious injury could occur if a power tool is tipped, or if a cutting tool is unintentionally contacted.

**CHECK FOR DAMAGED PARTS**

Before using a power tool, check for damaged part. A guard or any other part that is damaged should be carefully checked to determine if would operate properly and perform its intended function. Always check moving parts for proper alignment or binding. Check for broken parts and mountings and all other conditions that may affect the operation of the power tool. A guard, or any damaged part, should be properly repaired or replaced.

**DIRECTION OF FEED**

**ALWAYS** feed work into a blade or cutter against the direction of rotation. A blade or cutter should always be installed such that rotation is in the direction of the arrow imprinted on the side of the blade or cutter.

**NEVER LEAVE A TOOL UNATTENDED**

**TURN POWER OFF** - Do not leave a tool until it comes to a complete stop. Always turn a power tool OFF when leaving the work area, or, when a cut is finished.

---

**CALIFORNIA PROPOSITION 65 MESSAGE**

---

**WARNING**

Some dust created by power sanding, sawing, grinding, drilling, and other construction activities contain chemicals known (to the State of California) to cause cancer, birth defects or other reproductive harm. Some examples of these chemicals are:

- Lead, from lead-based paints
- Crystalline silica, from bricks and cement and other masonry products
- Arsenic and chromium, from chemically treated lumber

For further information, consult the following sources:

<http://www.osha.gov/SLTC/silicacrystalline/index.html>

<http://www.cdc.gov/niosh/consilic.html>

<http://oehha.ca.gov/prop65/law/P65law72003.html>

<http://www.dir.ca.gov/Title8/sub4.html>

Your risk from these exposures varies depending on how often you do this type of work. To reduce your exposure to these chemicals, work in a well-ventilated area, and work with approved safety equipment, such as those dust masks that are specially designed to filter out microscopic particles.



**HAZARD SYMBOLS**

---

**ELECTRICAL SHOCK**

**NEVER** touch electrical wires or components while the engine is running. They can be sources of electrical shock which could cause severe injury or burns.

**ROTATING PARTS**

Keep hands, feet, hair, and clothing away from all moving parts to prevent injury. Never operate the motor with covers, shrouds, or guards removed.

**OVER SPEED**

**NEVER** tamper with the governor components or settings to increase the maximum speed. Severe personal injury and damage to the motor or equipment can result if operated at speeds above maximum.

**DO NOT EXPOSE TO RAIN**

**DO NOT** expose to rain or use in damp locations.

**WARNING**

Sawing and drilling generates dust. Excessive airborne particles may cause irritation to eyes, skin and respiratory tract. To avoid breathing impairment, always employ dust controls and protection suitable to the material being sawed or drilled; See OSHA (29 CFR Part 1910.1200).

**WARNING**

Diamond Blades improperly used are dangerous. Comply with American National Standards Institute Safety Code, B7.1 and, Occupational Safety and Health Act covering Speed, Safety Guards, Flanges, Mounting Procedures, General Operating Rules, Handling, Storage and General Machine Conditions.



## ELECTRICAL REQUIREMENTS AND GROUNDING INSTRUCTIONS

In order to prevent potential electrical shock and injury, the following electrical safety precautions and symbols should be followed at all times!



### WARNING

In case of a malfunction or breakdown, grounding provides a path of least resistance for electric current to reduce the risk of electric shock. This tool is equipped with an electric cord having an equipment-grounding conductor and a grounding plug. The plug must be plugged into a matching outlet that is properly installed and grounded in accordance with all local codes and ordinances.

- Do not modify the plug provided – if it will not fit the outlet; have the proper outlet installed by a qualified electrician
- Improper connections of the equipment-grounding conductor can result in a risk of electric shock. The equipment-grounding conductor is the insulated conductor that has an outer surface that is green, with or without yellow stripes. If repair or replacement of the electric cord or plug is necessary, do not connect the equipment-grounding conductor to a live terminal
- Check with a qualified electrician or service personnel if the grounding instructions are not completely understood, or if in doubt as to whether the tool is properly grounded
- Use only 3-wire extension cords that have 3-prong grounding plugs and 3-pole receptacles that accept the tool's plug
- Repair or replace a damaged or worn cord immediately



### WARNING

This tool is intended for use on a circuit that has an outlet that looks like the one shown in Sketch A. The tool has a grounding plug that looks like the plug illustrated in Sketch A. A temporary adapter, which looks like the adapter illustrated in sketches B and C, may be used to connect this plug to a 2-pole receptacle as shown in Sketch B, if a properly grounded outlet is not available. The temporary adapter should be used only until a properly grounded outlet can be installed by a qualified electrician. The green-colored rigid ear, lug, and the like, extending from the adapter, must be connected to a permanent ground such as a properly grounded outlet box.

**NOTE:** Use of a temporary adapter is not permitted in Canada.

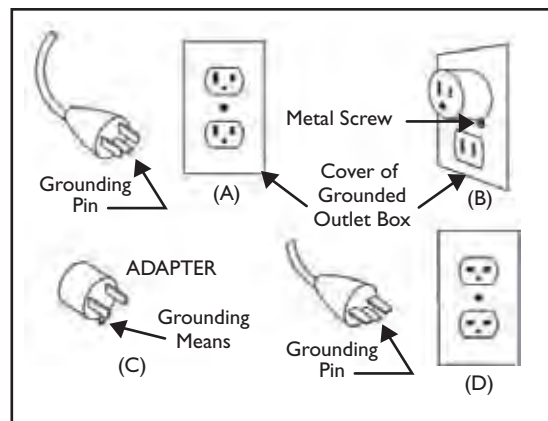

**Circuit and Adapter Information**

**WARNING**

To avoid the possibility of the appliance plug or receptacle getting wet, position the machine to one side of a wall mounted receptacle. This will prevent water from dripping onto the receptacle or plug. A “drip loop,” shown in the picture below, should be arranged by the user to properly position the power cord relative to the power source.

The “drip loop” is that part of the cord below the level of the receptacle, or the connector, if an extension cord is used. This method of positioning the cord prevents the travel of water along the power cord and coming in contact with the receptacle.

If the plug or receptacle gets wet, **DO NOT** unplug the cord. Disconnect the fuse or circuit breaker that supplies power to the tool. Then unplug and examine for presence of water in the receptacle.

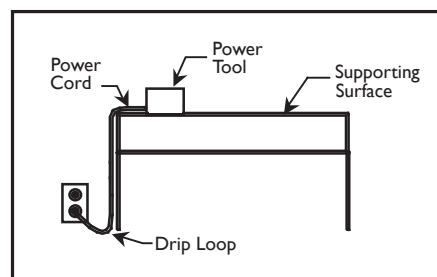

**Drip Loop Information**

**WARNING**

Use only extension cords that are intended for outdoor use. These extension cords are identified by a marking “Acceptable for use with outdoor appliances; store indoors while not in use.” Use only extension cords having an electrical rating not less than the rating of the product. Do not use damaged extension cords. Examine extension cords before using and replace if damaged. Do not abuse extension cords and do not yank on any cord to disconnect. Keep cords away from heat and sharp edges. Always disconnect the extension cord from the receptacle before disconnecting the product from the extension cord.

**WARNING**

To reduce the risk of electrocution, keep all connections dry and off the ground. Do not touch the plug with wet hands.

**WARNING**

Use of under sized extension cords result in low voltage to the motor that can result in motor burnout and premature failure. MK Diamond warns that equipment returned to us showing signs of being run in a low voltage condition, through the use of undersized extension cords will be repaired or replaced totally at the customer's expense. There will be no warranty claim.

To choose the proper extension cord:

- Locate the length of extension cord needed in the table below.
- Once the proper length is found, move down the column to obtain the correct AWG size required for that length of extension cord.

EXTENSION CORD MINIMUM GAGE FOR LENGTH				
VOLTS	TOTAL LENGTH OF CORD IN FEET			
	25 ft. AWG	50 ft. AWG	100 ft. AWG	150 ft. AWG
120v	18	16	14	12

**TILE SAW SPECIFIC WARNINGS****WARNING**

Wear eye protection.

Use splash guard for every operation for which it can be used.

Disconnect saw before servicing, when changing cutting blades, and cleaning.

Replace damaged cutting blade before operating.

**SAFETY LABEL LOCATIONS**

The warning labels contain important safety information. Please read the information contained on each safety label. These labels are considered a permanent part of your saw. If a label comes off or becomes hard to read, contact MK Diamond or your dealer for a replacement.

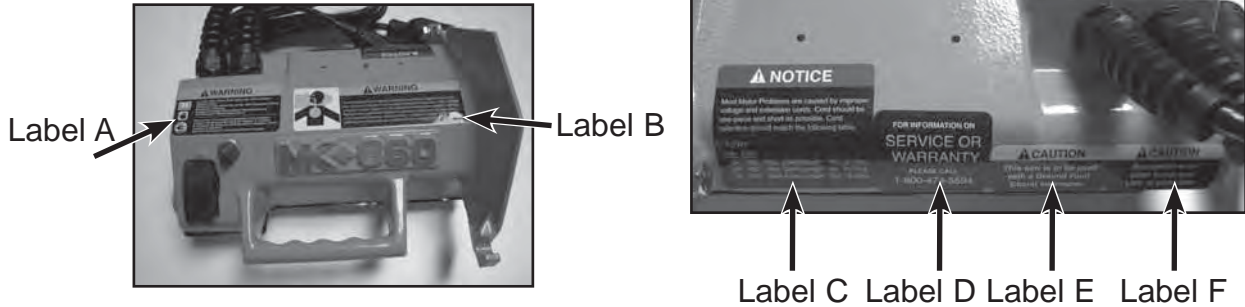

Label A

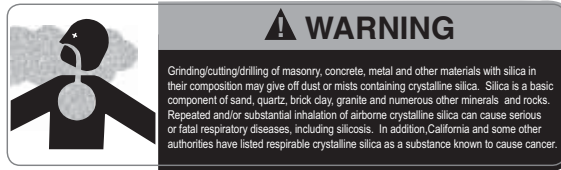

Label B

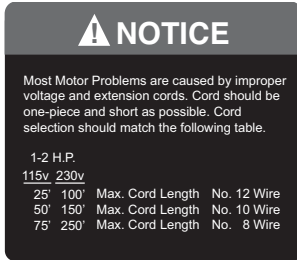

Label C



Label D

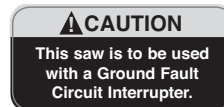

Label E

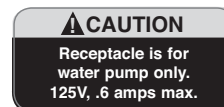

Label F

Tile Master Label Sheet Part#166012

Decal/Label	Location	Description
A	Cutting Head Front	Warning - Read Owner's Manual
B	Cutting Head Front	Warning - Silica Warning
C	Cutting Head Back	Notice - Voltage / extension cords
D	Cutting Head Back	Service / Warranty
E	Cutting Head Back	Caution - Use with GFCI only
F	Cutting Head Back	Caution - Receptacle for water pump

**PRODUCT SPECIFICATIONS**

---

The MK-660 Saw is a versatile Tile Saw. Operated and used according to this manual, the MK-660 will provide years of dependable service.

**GENERAL DESCRIPTION**

---

The MK-660 Saw is engineered as a tabletop or stand mounted wet tile saw. The saw includes a powerful 120v electric motor. The saw is capable of cutting tile up to fourteen (14) inches in length. The saw can cut an object two (2) inches thick in one pass.

**MOTOR SPECIFICATIONS**

---

Motor specifications for the MK-660 Saw are listed in the table below:

<b>Voltage</b>	120v
<b>Motor Only Amperage</b>	8.8 a
<b>Frequency</b>	60Hz
<b>RPM</b>	3500 rpm
<b>Horse Power</b>	3/4 hp
<b>Weight</b>	53 lbs.

**BLADE CAPACITY**

---

The MK-660 Saw uses a seven (7) inch (178mm) diameter, wet cutting continuous rim, MK Diamond blade with a five-eighths (5/8) inch (15.875 mm) arbor.

**TILE TYPES**

---

The MK-660 Saw can cut a variety of tile types including stone, masonry, and lapidary products.

**NOTE:** The MK-660 Saw is not designed to cut plastic or metals.

**UNPACKING**

Your MK-660 Saw has been shipped from the factory thoroughly inspected. Only minimal assembly is required.

**! CAUTION** Use proper lifting techniques when lifting the MK-660 Saw.

If not done, remove the MK-660 Saw, Cutting Head and accessory box from the carton.

**CONTENTS**

In your container, you will find one (1) MK-660 Frame and Water Pan, one (1) MK-660 Cutting Head, (1) Cutting Head Height Adjusting Knob, (1) Height Adjusting Knob Flat Washer, one (1) 7-inch Wet Cutting Continuous Rim Diamond Blade, one (1) Adjustable Cutting Guide, one (1) Electric Water Pump, one (1) Pump Discharge Fitting, one (1) Cooling Transfer Tube, one (1) Flow Adjusting Clamp, one (1) Drain Plug, one (1) Blade Wrench, one (1) Table Clip, one (1) Inner Flange Wrench, (1) Splash Guard, one (1) Owner's Manual, one (1) Pump Manual and one (1) Warranty Card.



MK-660 Frame and Water Pan



MK-660 Cutting Head



Height Adjusting Knob

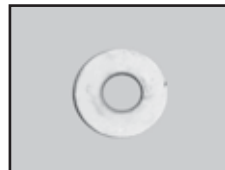

Height Adjusting Knob Flat Washer



Diamond Blade



Adjustable Cutting Guide



Electric Water Pump



Pump Discharge Fitting



Cooling Transfer Tube



Flow Adjusting Clamp



Drain Plug



Blade Wrench and Table Clip



Inner Flange Wrench

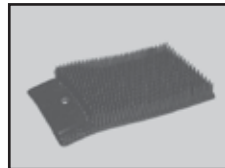

Splash Guard



Owner's Manual



Pump Manual

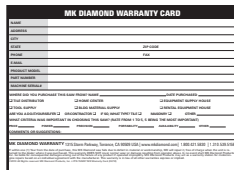

Warranty Card

**TRANSPORT**

**! CAUTION**

1. The MK-660 Saw weighs approximately fifty-three (53) pounds; use care when transporting.
2. Never transport the MK-660 Saw with water in the Water Pan.

The MK-660 Saw is designed with a rigid frame and removable Cutting Head. Always use proper lifting techniques when lifting the MK-660 Saw.

To lift the saw, grasp the front and back of the frame at the lift points shown below.



**STAND (Optional)**

**! CAUTION**

The MK-660 Saw weighs fifty-three (53) pounds; follow the guidelines in the TRANSPORT section when placing it on the stand (MK Diamond Part# 151889).

**NOTE:** If using the Optional MK Diamond Stand, follow these steps:



(A)  
Open the stand and place on flat surface

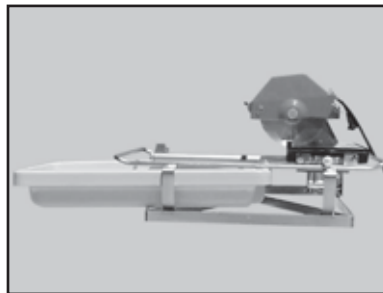

(B)  
Remove Water Basin, place saw on stand



(C)  
Ensure saw frame is positioned properly

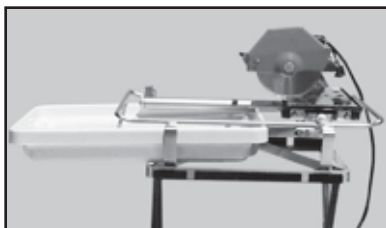

(D)  
Reinstall the Water Basin



**CUTTING HEAD INSTALLATION**

Follow the assembly instructions to prepare your MK-660 Saw for operation.

**NOTE:** If the Cutting Head is installed, go to step next step.



(A)

Place the Flat Washer onto the Height Adjusting Knob

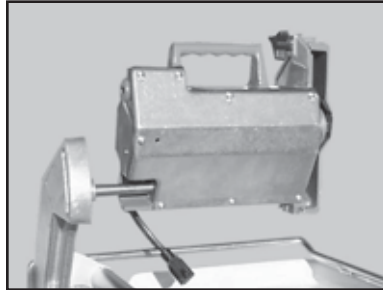

(B)

Align Cutting Head Pivot Hole to the Post, Pivot Shaft

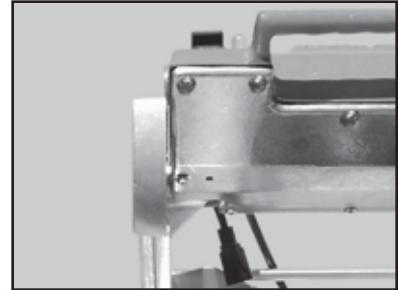

(C)

Verify the Cutting Head is completely installed and seated on the Pivot Shaft

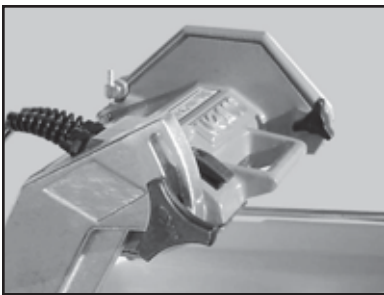

(D)

Install the Adjusting Knob

**DIAMOND BLADE INSTALLATION**

**NOTE:** When installing the Retaining Screw, do not "cross-thread" and DO NOT over tighten the screw.



(A)

Loosen the Blade Guard Retaining Screw

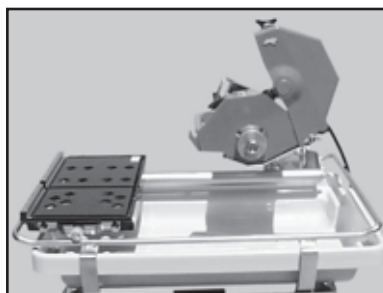

(B)

Open the Outer Blade Guard to expose the Retaining Nut and Flanges



(C)

Using the Blade Nut Wrench, loosen and then remove the Retaining Nut and Outer Flange

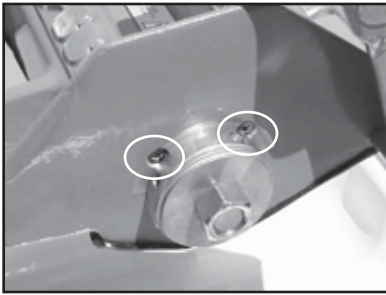

(D)  
Locate the Inner Flange  
Wrench Retaining Holes

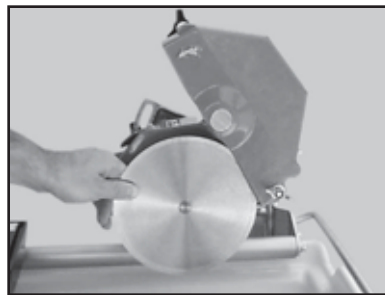

(E)  
Install Diamond Blade  
onto Blade Shaft

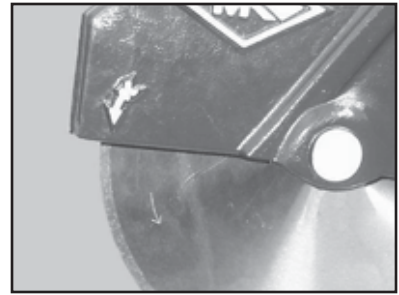

(F)  
Verify the Blade is seated on the  
Blade Shaft and direction  
of rotation is correct



(G)  
Install the Retaining Nut and Outer  
Flange. Hold the Shaft using the  
Inner Flange Retaining Wrench  
and tighten using the Blade  
Wrench



(H)  
Close the Outer Blade Guard  
and tighten the Blade Guard  
Retaining Screw

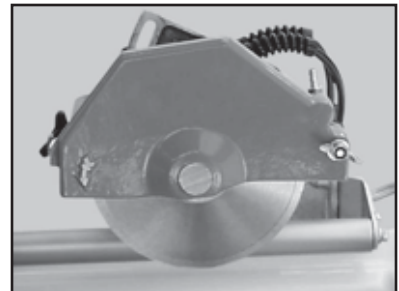

(I)  
Tighten the Outer Blade Guard  
Pivot Screw

**ADJUSTABLE CUTTING GUIDE INSTALLATION**

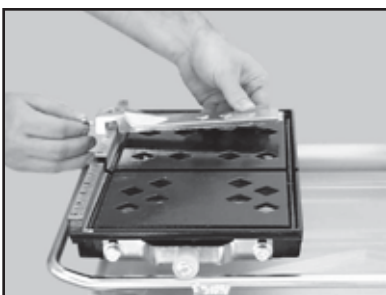

(A)  
Loosen adjustable Cutting  
Guide retaining thumbscrew and  
place it over the movable  
Cutting Table Ruler/Stop



(B)  
Place the adjustable Cutting  
Guide onto the movable Cutting  
Table Ruler/Stop and tighten the  
retaining thumbscrew

**SPLASH GUARD INSTALLATION**

Follow the assembly instructions to prepare your MK-660 Saw for operation.



(A)

Install the retaining thumbscrew through the washer and Splash Guard, then align to the hole



(B)

Install the Splash Guard onto the Blade Guard

**WATER PUMP INSTALLATION**

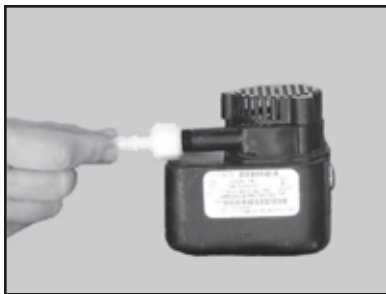

(A)

Install Water Pump Discharge Fitting



(B)

Press one end of the Cooling Transfer Tube onto the Water Pump Discharge Fitting

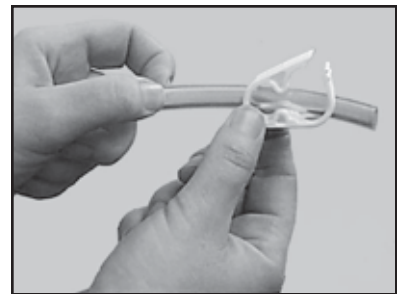

(C)

Slide Cooling Flow Adjusting Clamp onto the Cooling Transfer Tube

**PRE-START INSPECTION**

Prior to beginning work, a pre-start inspection of the saw should be preformed.

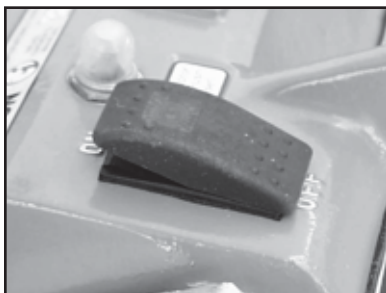

(A)

Ensure the ON/OFF Switch is in the OFF position

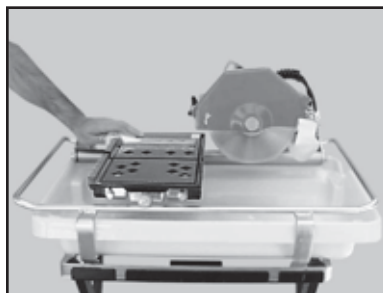

(B)

Verify the movable Cutting Table moves freely

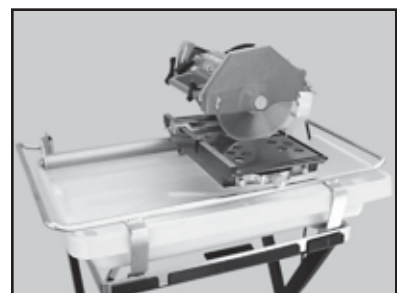

(C)

Inspect the Diamond Blade for damage - verify the blade is correct for the material being cut

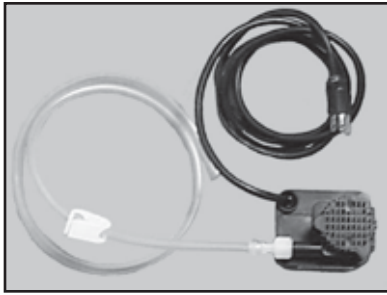

(D)

Inspect the Pump Assembly for damage - ensure the cord is free of cracks or cuts

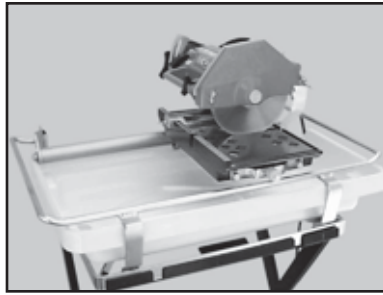

(E)

Inspect the MK-660 for damage - ensure the cord is free of cracks or cuts

**CONNECTING THE WATER PUMP**

Prior to beginning work, a pre-start inspection of the saw should be performed.

- WARNING** 1. To prevent the possibility of electrical shock, the MK-660 Saw MUST be de-energized when connecting the Water Pump.



2. To prevent the possibility of electrical shock, use only MK Diamond qualified replacement parts.

**NOTE:** To prevent pump damage, the Water Pump must be disconnected if cutting with a Dry Blade.

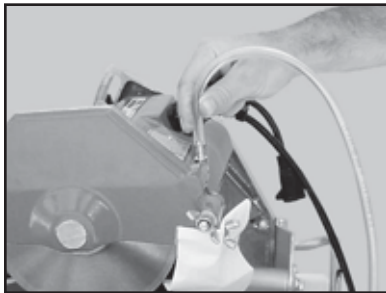

(A)

Connect the Coolant Transfer Tube to the inlet connection of the Blade Guard



(B)

Connect the Water Pump power cord to the connection found on the back of the motor

**WATER PUMP SETUP FOR OPERATION**

The Water Pump can be setup for operation in two ways, External Water Source or Re-circulation.

**NOTE:** To prevent pump damage, the Water Pump must be disconnected if cutting with a Dry Blade.



(A)  
Remove the Drain Plug



(B)  
Place the Water Pump  
in an external container

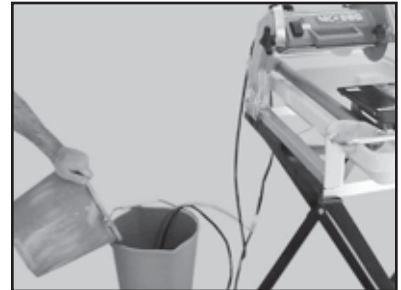

(C)  
Fill the external container until  
water completely covers the  
Water Pump suction



(A)  
Place an external catch Basin  
below the Water Pan drain  
hole

**RECIRCULATION**

**NOTE:** When using the re-circulation method, the water should be changed often for longer pump life.



(A)  
Ensure the Drain Plug is in-  
stalled in the Water Pan



(B)  
Place the Water Pump in the  
back of the Water Pan

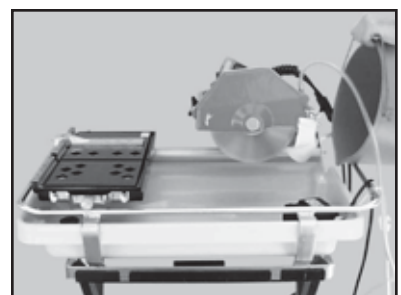

(C)  
Fill the Water Pan until water  
completely covers the Water  
Pump suction

**MK-660 SAW SETUP FOR OPERATION****CAUTION**

1. Check for damaged, broken, or missing parts.
2. Verify the On/Off switch is in the OFF position.
3. Before connecting the MK-660 Saw to a power supply, be sure the voltage, cycle and phase of the job site power source meet the requirements of the table below:

VOLTAGE:	120v
CYCLE:	60hz
PHASE:	1-phase

4. If using an extension power cord, make sure the length and wire gauge correspond to the requirements listed in the table on page 10. An extension power cord that is too small in wire gauge (diameter), or too long in length, will cause the motor to overheat and could cause premature failure.
5. Use an approved Ground Fault Circuit Interrupter (GFCI).
6. Do not cover the motor vents as this could lead to motor overheating.

**NOTE:** In order to avoid breaker tripping, a 20-amp circuit breaker should be used.



- (A) Ensure the ON/OFF Switch is in the OFF position
- (B) Plug MK-660 Saw into the GFCI
- (C) Plug the GFCI into the power source

**NOTE:** MK Diamond has available, as an accessory item, (Part # 152610) a plug-in GFCI that may be plugged into a properly installed and grounded 3-pole outlet.

**PORTABLE GENERATOR**

If using a portable generator to provide power, ensure the generator meets the following minimum requirements: 8 KW 120/240 volts 66.7/33.3 amps Single Phase



**CUTTING STRAIGHT EDGES**

**⚠ CAUTION DO NOT FORCE THE TOOL.** It will do the job better and safer at the rate for which it was designed.

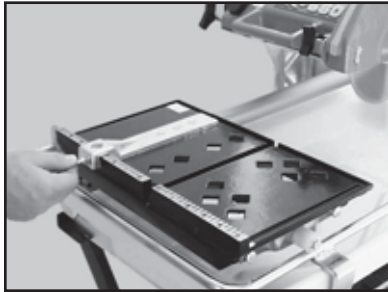

(A)

Loosen the adjustable Cutting Guide retaining thumbscrew

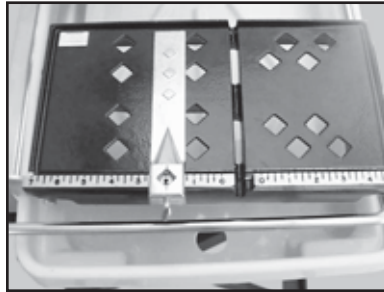

(B)

Position the adjustable Cutting Guide to desired cut length indicated inside the diamond

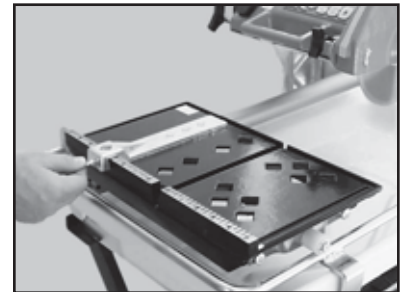

(C)

Tighten the retaining thumbscrew



(D)

Place the tile against the Ruler/Stop and Cutting Guide

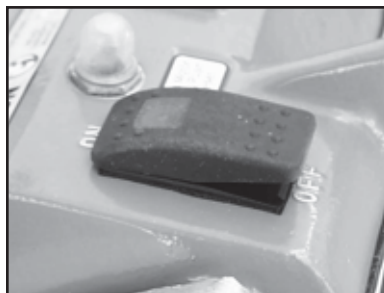

(E)

Turn the motor ON

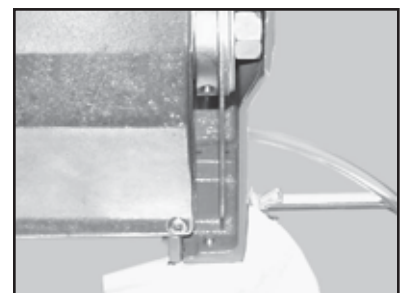

(F)

Verify flow on both sides of the blade (See Maintenance Section to adjust flow)

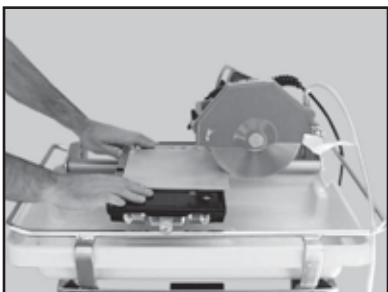

(G)

Perform the cut

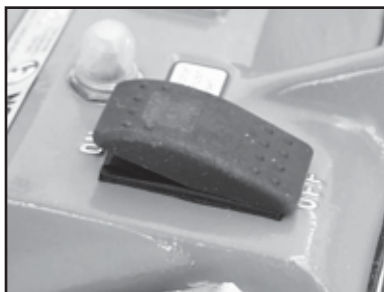

(H)

Turn the motor OFF when work is complete



**DIAGONAL CUTTING**

**NOTE:** To cut 45° Diagonals, the 45° Flat Angle Guide (MK Diamond Part No. 134577-MK) should be used.

**⚠ CAUTION DO NOT FORCE THE TOOL.** It will do the job better and safer at the rate for which it was designed.



(A)  
Remove the adjustable Cutting Guide



(B)  
Place the Dual 45° Flat Angle Guide on the Ruler/Stop

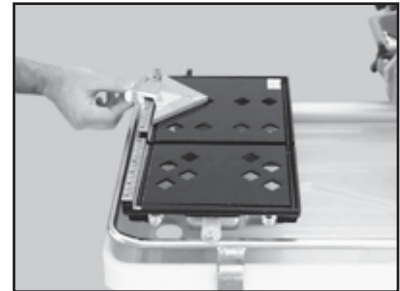

(C)  
Position the Dual 45° Flat Angle Guide and tighten the retaining thumbscrew

**NOTE:** If cutting the tile in two equal halves, align the tile in the V-notch of the movable Cutting Table Ruler/Stop.

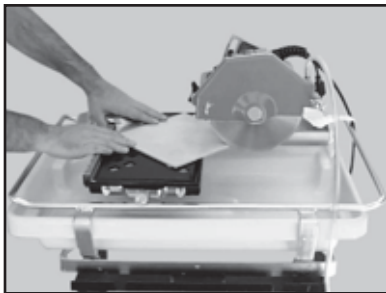

(D)  
Position the tile against the Dual 45° Flat Angle Guide and the Ruler/Stop

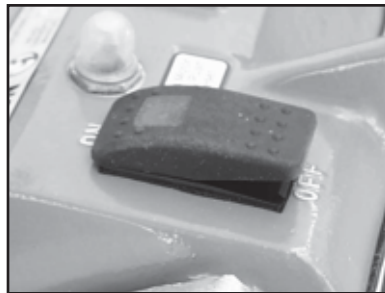

(E)  
Turn the motor ON

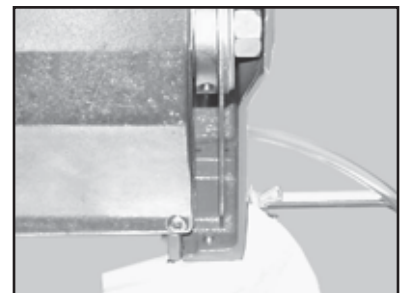

(F)  
Verify cooling flow on both sides of the blade (See Maintenance Section to adjust flow)

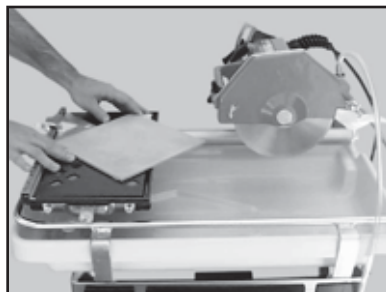

(G)  
Perform the cut

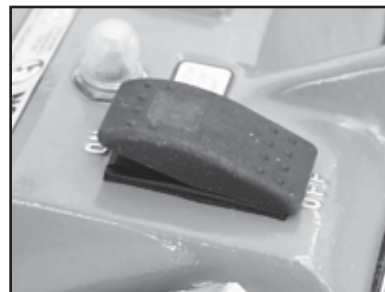

(H)  
Turn the motor OFF when work is complete

**45° MITER CUTTING**

**NOTE:** To cut 45° Miters, the 45° Bullnose Miter Guide (MK Diamond Part No. 153201-MK) should be used.

**⚠ CAUTION DO NOT FORCE THE TOOL.** It will do the job better and safer at the rate for which it was designed.

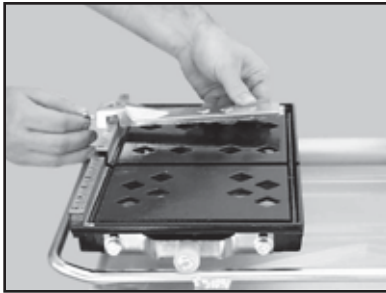

(A)  
Remove the adjustable Cutting Guide

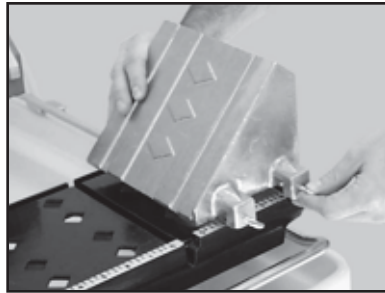

(B)  
Place the 45° Bullnose Miter Guide on the Ruler/Stop

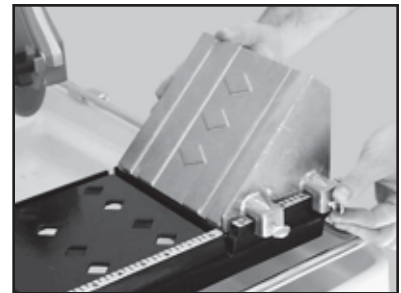

(C)  
Position the 45° Bullnose Miter Guide and tighten the retaining thumbscrew

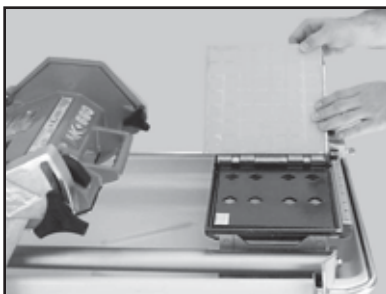

(D)  
Position the tile on the 45° Bullnose Miter Guide and the Ruler/Stop



(E)  
Turn the motor ON

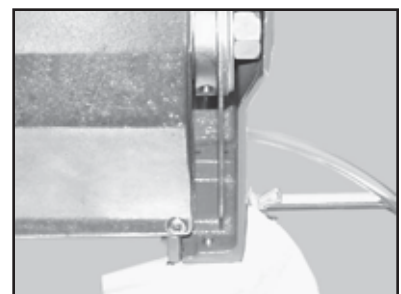

(F)  
Verify cooling flow on both sides of the blade (See Maintenance Section to adjust flow)



(G)  
Perform the cut

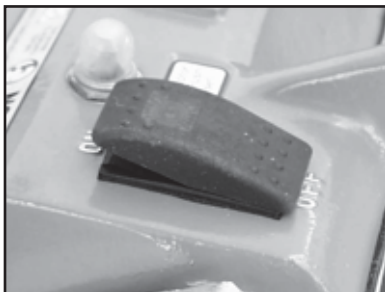

(H)  
Turn the motor OFF when work is complete

**OFF-ANGLE CUTTING**

**NOTE:** To cut angles other than 45° angles, a Protractor (MK Diamond Part No. 134569-MK) should be used.

**⚠ CAUTION DO NOT FORCE THE TOOL.** It will do the job better and safer at the rate for which it was designed.

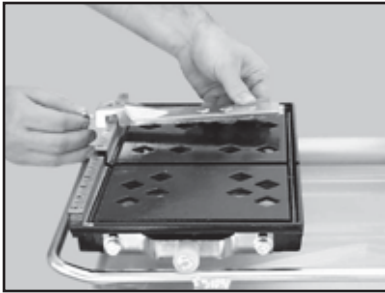

(A)  
Remove the adjustable Cutting Guide

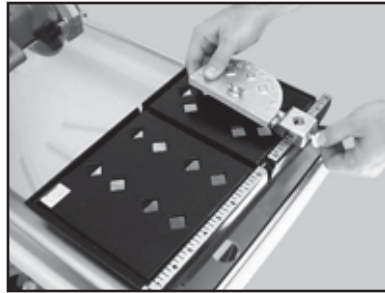

(B)  
Place the Protractor on the Ruler/Stop

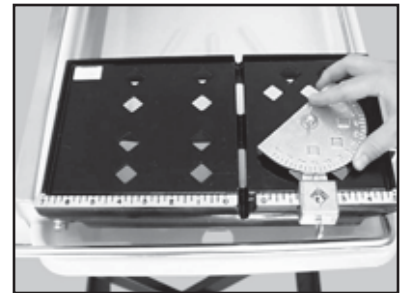

(C)  
Set the desired angle and tighten the thumbscrew

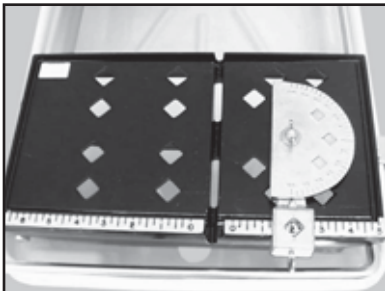

(D)  
Position the Protractor cutting guide to the desired cut length indicated inside the diamond

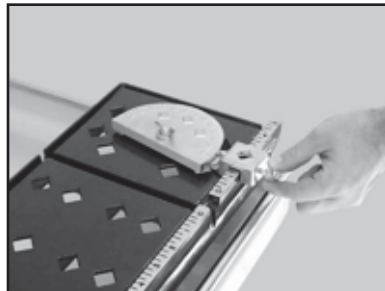

(E)  
Tighten the retaining thumbscrew



(F)  
Position the tile against the Protractor and the Ruler/Stop



(G)  
Turn the motor ON

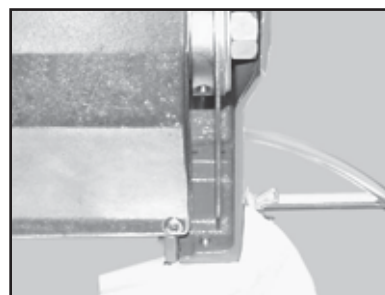

(H)  
Verify flow on both sides of the blade (See Maintenance Section to adjust flow)



(I)  
Perform the cut

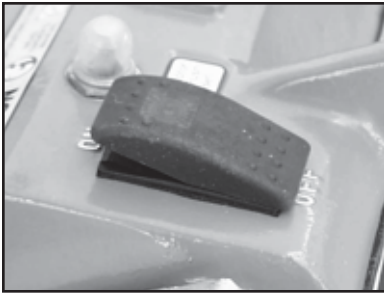

(J)  
Turn the motor OFF when work is complete

**CLEANUP**

- NOTE:** 1. If an external water source was used, steps A through C may be skipped.  
2. Dispose of wastewater in accordance with applicable Federal, State and Local laws.

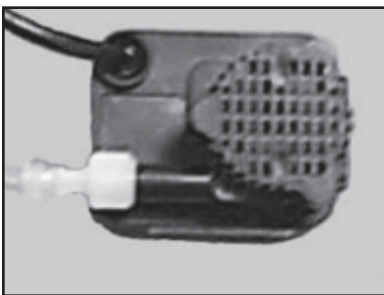

(A)  
Clean the Water Pump suction of all debris



(B)  
Place the Water Pump in an external container

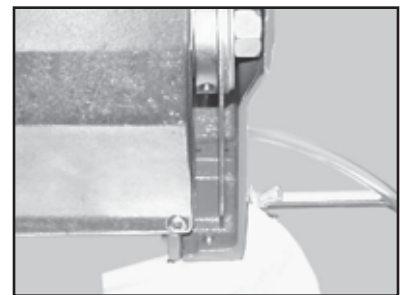

(C)  
Run the MK-660 Saw until clear water is seen at the blade coolant ports (Approx. one (1) minute)

**CAUTION** Ensure the saw is disconnected before completing the remainder of the cleanup process.

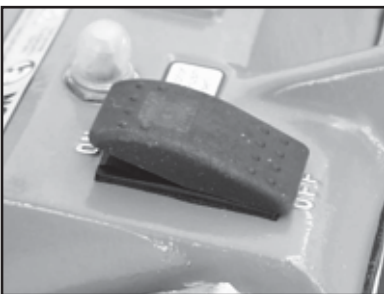

(D)  
Ensure the ON/OFF switch is in the OFF position



(E)  
Unplug the GFCI from the power source



(F)  
Unplug MK-660 from the GFCI



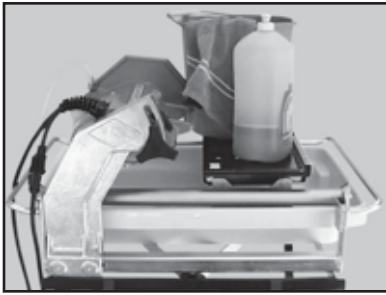

(G)  
Clean the MK-660 Saw with soap and clean water

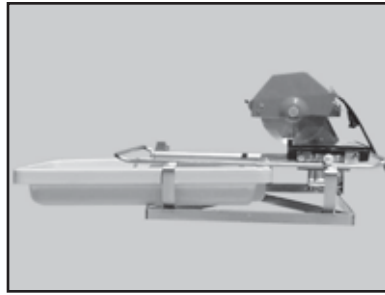

(H)  
Remove the Water Pan from the MK-660 Saw



(I)  
Clean the Water Pan

**CAUTION** Ensure water is not forced into the motor casing when cleaning.



(J)  
Clean the movable Cutting Table Guide Bar



(K)  
Clean the movable Cutting Table Roller Wheel Frame Support

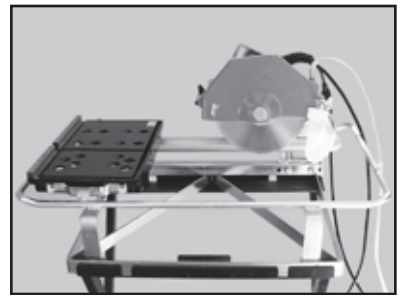

(L)  
Clean the remainder of the MK-660 Saw

**MAINTENANCE FOLLOWING USE**

To extend the life of the MK-660 Saw, the following procedure should be performed after each use. Lubricate all points listed below with light oils such as, 3 in 1, WD-40, etc.



(A)  
Ensure the ON/OFF switch is in the OFF position



(B)  
Unplug MK-660 Saw



(C)  
Lubricate the Guide Bar



(D)  
Lubricate the Roller Wheel  
Assembly

**MONTHLY MAINTENANCE**

The following maintenance should be performed monthly.



(A)  
Remove the Diamond Blade

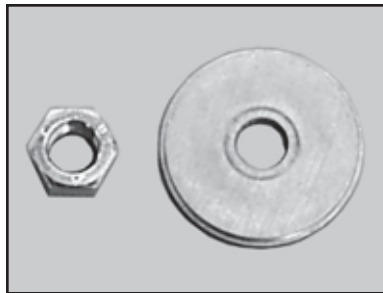

(B)  
Lubricate the Outer Flange and  
Retaining Nut

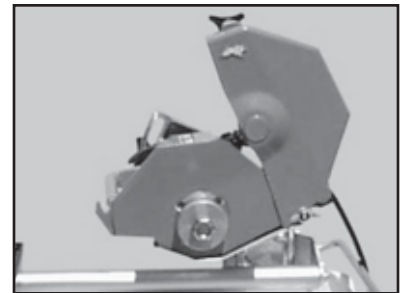

(C)  
Remove the Outer Blade  
Guard



(D)  
Remove the Inner Flange



(E)  
Clean around the Motor Shaft  
and clean the Inner Flange



(F)  
Lubricate the Motor Shaft  
and Inner Flange

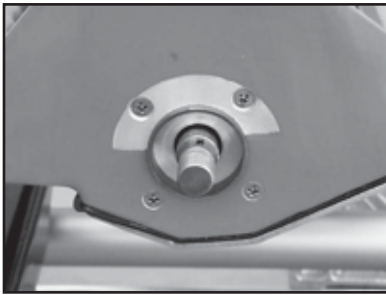

(G)  
Locate the Motor Shaft Alignment Pin

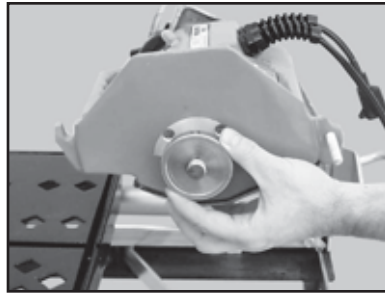

(H)  
Align the Alignment Slot of the Inner Flange to the Motor Shaft Alignment Pin and install the Inner Flange

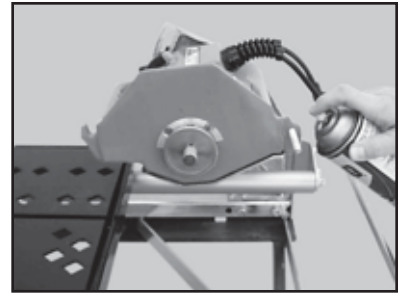

(I)  
Lubricate the Outer Blade Guard Pivot Shaft

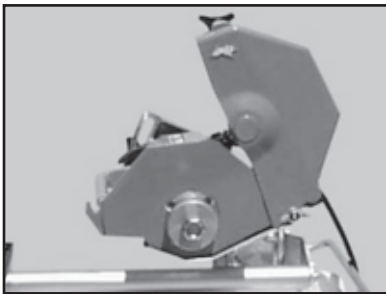

(J)  
Install the Outer Blade Guard

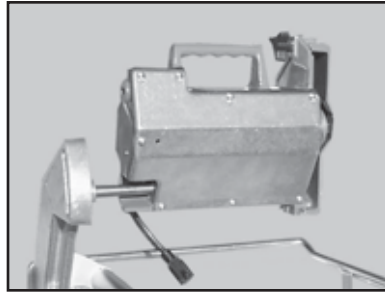

(K)  
Remove the Cutting Head



(L)  
Lubricate the Cutting Head Pivot Shaft



(M)  
Lubricate the Cutting Head Adjustment Knob



(N)  
Lubricate the Cutting Head Adjustment Knob retaining holes

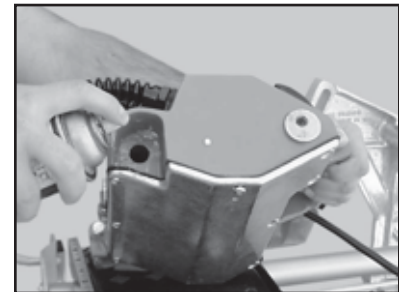

(O)  
Lubricate the Cutting Head Pivot Hole



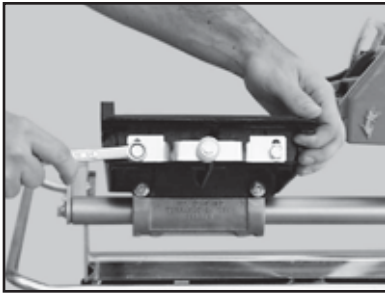

(P)  
Verify the Cutting Table Roller  
Wheel Assembly is tight

**FLOW ADJUSTMENT**

---

**NOTE:** If flow to the Diamond Blade requires adjustment, perform the following actions:

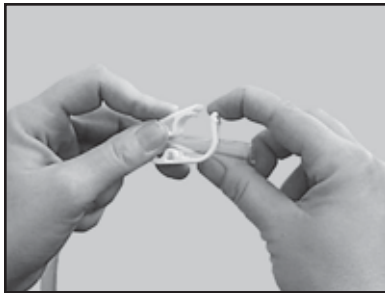

(A)  
Increase cooling flow by  
releasing the Flow Adjusting  
Clamp



(B)  
Reduce cooling flow by Press-  
ing down on the Flow Adjusting  
Clamp

**BLADE DRESSING**

Like most cutting instruments, a Diamond Blade performs best when it is dressed. Over time and use, diamonds on the outer edge of the blade will become smoothed or "glazed" over. This will reduce grinding efficiency and may cause the blade to "wander" or bend giving the illusion of an alignment problem. When this occurs, the blade will need to be dressed. The Diamond Blade can be dressed using the MK Dressing Stick (part# 152972) and by following the steps below.

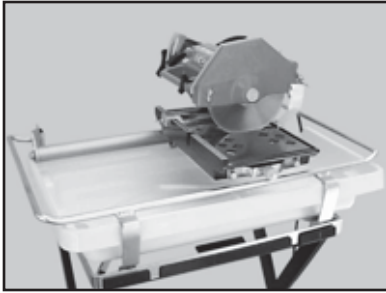

(A)  
Setup the MK-660 Saw for operation (see Setup, Adjustment and Operation)

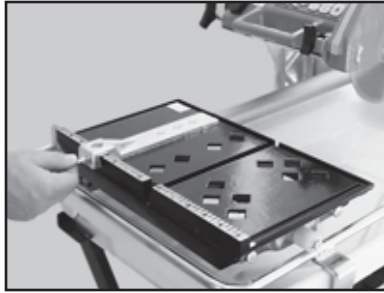

(B)  
Set the adjustable Cutting Guide to cut a 1/16-strip



(C)  
Position the Dressing Stick

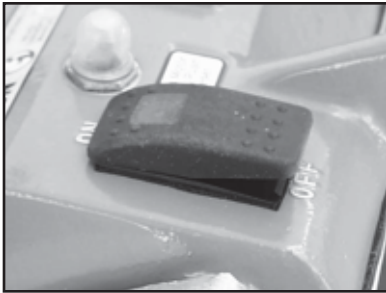

(D)  
Turn the motor ON

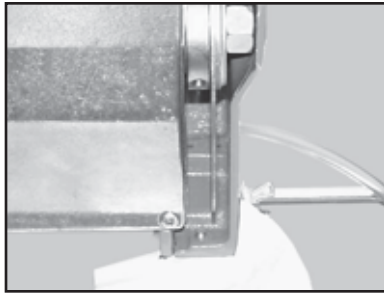

(E)  
Verify flow on both sides of the blade (See Maintenance Section to adjust flow)



(F)  
Cut the Dressing Stick seven (7) or eight (8) times to dress the Blade

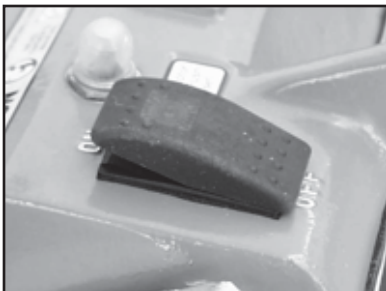

(G)  
Ensure the ON/OFF switch is in the OFF position

**DIAMOND BLADE CHANGE-OUT**

**NOTE:** When installing the Retaining Screw, do not "cross-thread" and DO NOT over tighten the screw.

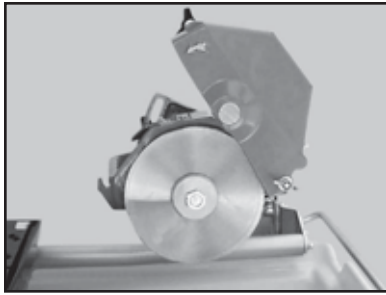

(A)  
Open the Outer Blade Guard

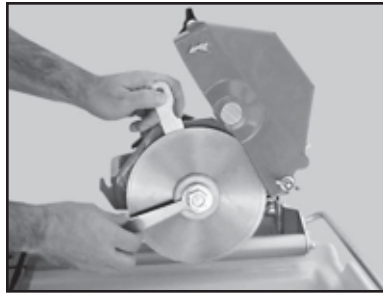

(B)  
Remove Retaining Nut and  
Outer Flange

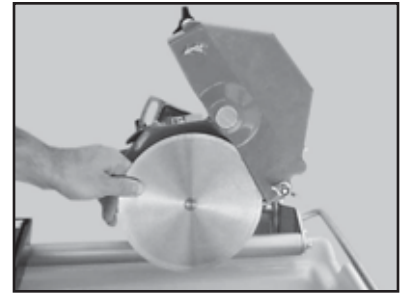

(C)  
Remove Diamond Blade  
from Blade Shaft

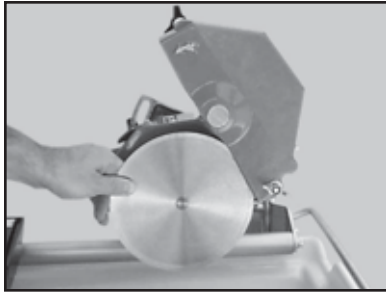

(D)  
Install the Diamond Blade  
onto Blade Shaft

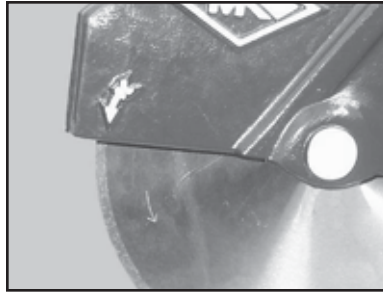

(E)  
Verify the Blade is seated on  
the Blade Shaft and direction of  
rotation is correct

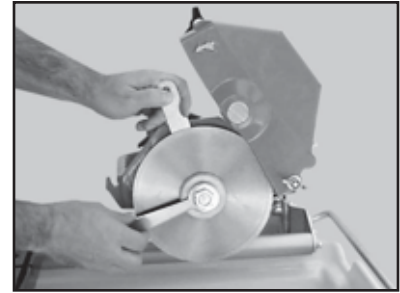

(F)  
Install the Retaining Nut and Outer  
Flange. Hold the Blade Shaft  
using the Inner Flange Retain-  
ing Wrench and tighten using the  
Blade Wrench



(G)  
Close the Outer Blade Guard  
and tighten the Blade Guard  
Retaining Screw

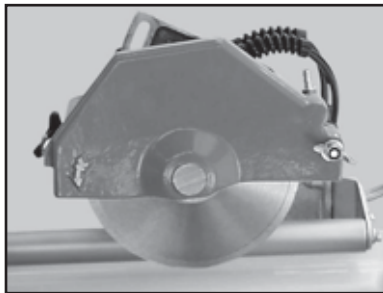

(H)  
Tighten the Outer Blade Guard  
Pivot Screw

**BLADE WILL NOT CUT PROPERLY**



(A)  
Check for Smoothness or "Glazing" (Dress blade if needed)

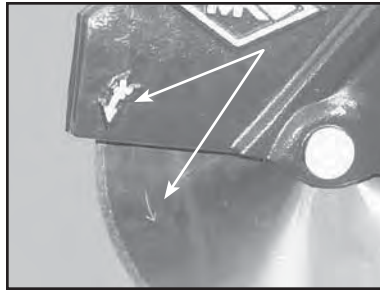

(B)  
Check for proper rotation

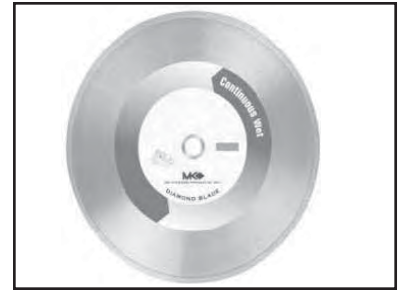

(C)  
Ensure the Blade Core is not bent and Arbor is not out of round



(D)  
Verify the blade is correct for the material being used

**MOVABLE CUTTING TABLE DOES NOT MOVE CORRECTLY**



(A)  
Check that the Guide Bar is clean – clean if dirty



(B)  
Check the movable Cutting Table Roller Wheel for wear replace if necessary

## COOLING FLOW



(A)  
Check Flow Adjusting  
Clamp is open. If flow exists,  
go to Step B



(B)  
Remove the Transfer Tube  
from the Blade Guard inlet,  
go to Step C

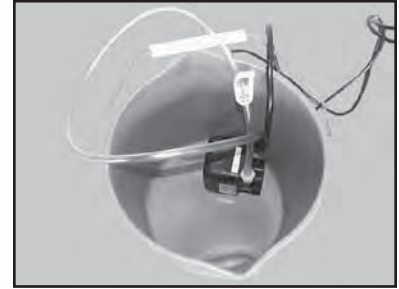

(C)  
Place Pump into a bucket of  
water and check flow. If flow  
exists, go to Step D



(D)  
Remove the Transfer Tube  
and check flow. If flow exists,  
go to Step F



(E)  
Remove the Pump Discharge  
Fitting and check flow. If flow  
exists, go to Step F.

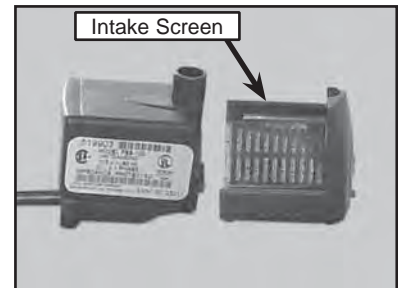

(F)  
Remove the Pump Intake  
Screen and check for debris.  
If flow exists, go to Step G.



(G)  
Remove the Blade Guard  
Intake Fitting, go to Step H.



(H)  
Clean the Blade Guard  
Intake Fitting, go to Step I.



(I)  
Rod Cooling Channels and  
recheck flow

**NOTE:** "Rodding" coolant channels is performed by inserting a small wire rod through the inlet on top of the Blade Guard and directing the rod out through each of the flow tubes located on the underside of the Blade Guard. The channels should be "rodded" until all ports are free of foreign debris.

**BLADE STOPS TURNING**

(A)  
Allow motor to cool and  
depress motor Overload  
Reset Switch



(B)  
Verify all plugs fully installed



(C)  
Check Ground Fault Circuit  
Interrupter (GFCI) is not tripped

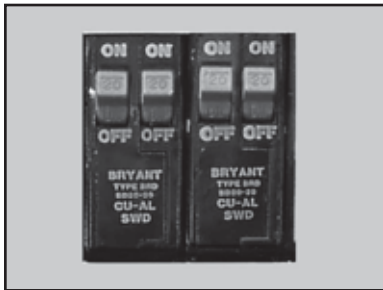

(D)  
Verify circuit breaker at least  
20 amps - if not, move to  
20-amp circuit



(E)  
Verify circuit breaker not  
tripped if tripped, reset once



(F)  
Check power source voltage  
is 120v - if not 120v, move to  
another circuit

**NOTE:** Using the proper blade when cutting any material will insure that additional drag is not induced on the motor thus increasing the amperage draw. Too much drag/ amperage draw can overheat the motor. A sign that the incorrect blade is being used for the material being cut is if user trips the circuit breaker at the power supply when cutting the material.





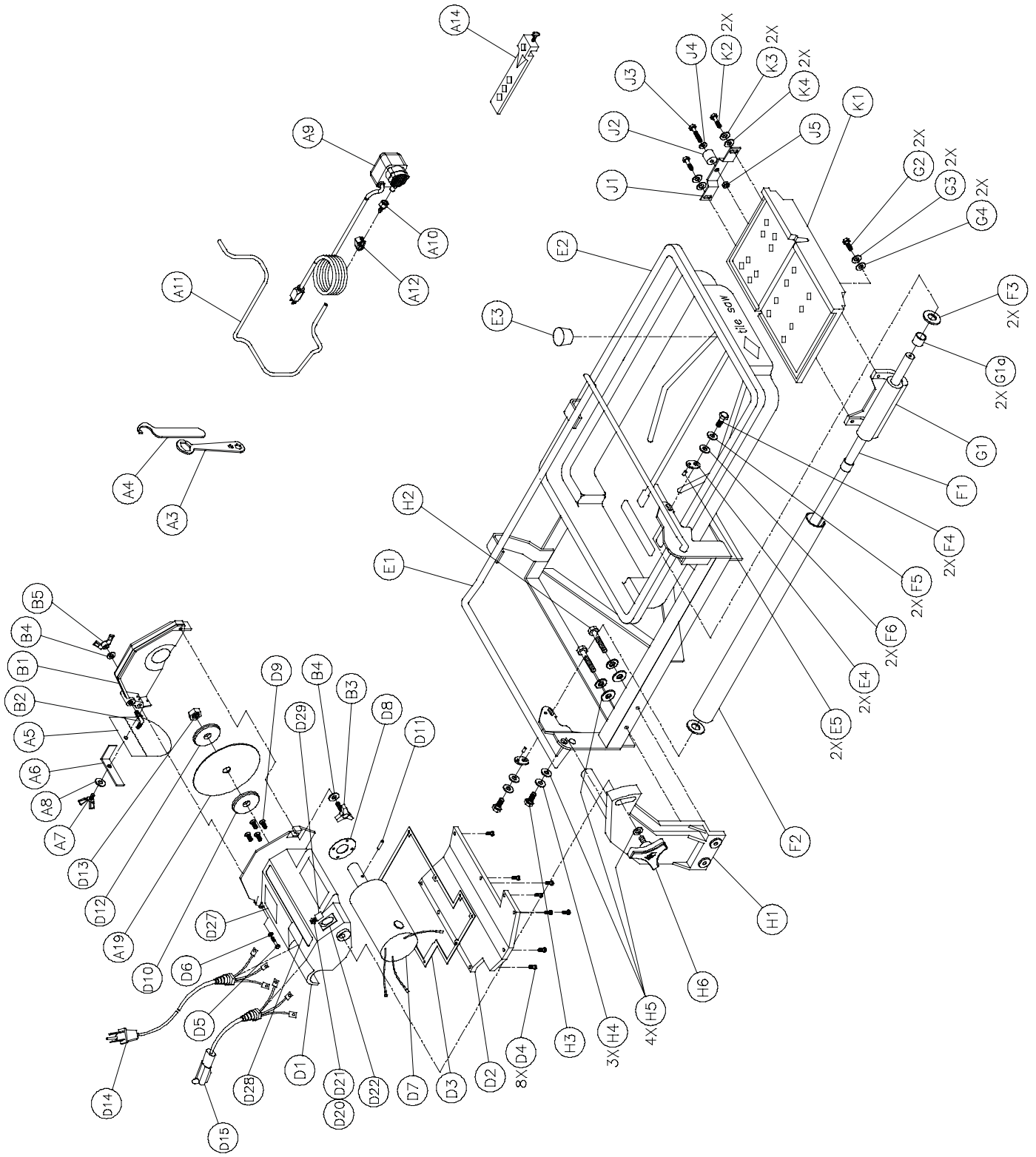



ITEM	DESCRIPTION	QTY	PART #
A	Accessories	1	n/a
A1	Carton, Accessory Pack, 660	1	153498
A3	Wrench, 15/16 Closed End	1	134684
A4	Wrench, Spanner, 660	1	154362
A5	Curtain, Splash	1	134841
A6	Bracket, Splash Curtain	1	152571
A7	Wing-screw, 1/4-20 x 1/2	1	151888
A8	Washer, 1/4 SAE Flat	1	151915
A9	Pump, Water, G-150A	1	151271
A10	Fitting, Plastic, 1/4 FNPT x 1/4 BARB	1	128397
A11	Hose, Vinyl, 1/4 ID	2'	132951
A12	Clamp, Flow, 1/4-1/2	1	154394
A13	Owner's Manual, Water Pump	1	155745
A14	Rip Guide Screw, 1/4-20 x 3/4 Thumb	1 1	134551 150991
A15	Large Bullnose Accessory Screw, 1/4-20 x 3/4 Thumb	1 2	153201 150991
A16	Owner's Manual, 660	1	153461
A19	Blade, 7 x 060 x 5/8, MK-100	1	153441
B	Blade Guard, 7", Assembly	1	154811-MK
B1	Guard, 7" Blade	1	151731
B2	Elbow, 1/8 MNPT x 1/4 BARB 90 Brass	1	154652
B3	Knob, Davies	1	151681
B4	Washer, 5/16 SAE Flat	2	151754
B5	Wing-nut, 5/16-18 Nylock	1	151746
D	Cutting Head (less blade guard)	1	n/a
D1	Cutting Head, 660	1	154291
D2	Cover, Cutting Head, 660	1	154293
D3	Gasket, Cover, 660	1	154381
D4	Screw, 10-24 x 5/8 Pan Head Phillips Self-Tapping Machine	8	153681
D5	Screw, 5/16-18 x 2 1/2 Hex Head Cap, Fully Threaded	1	151748
D6	Washer, 5/16 Split Lock	1	151747
D7	Motor, 3/4 HP 115V FWR, 660	1	154292
D7A	Motor, 3/4 HP 230V FWR, 660	1	153497
D8	Gasket, Thermal, 660	1	154346
D9	Screw, 10-24 x 5/8 Flat Head Phillips Machine	4	154295
D10	Flange, Inner, 660	1	154194
D11	Pin, 1/8 x 3/8 Spring	1	154982
D12	Flange, Outer	1	135830
D13	Nut, 5/8-18 UNF Hex	1	135848
D14	Cord, AC Power 120V (16/3 SJTW x 10', w/ molded 5-15P and Heyco 3251 Strain Relief)	1	153419
D15	Cord, Pump Pigtail, 16/3 SJTW x 1', w/ molded 5-15R and Heyco 3251 Strain Relief	1	154446
D16	Wire Harness, 660	1	153415
D17	Screw, 10-24 x 3/8 Pan Head Phillips Self-Tapping Machine	1	151262
D18	Resistor, 660	1	153535
D19	Tack, 1/4 Head	4	155659
D20	Switch, Thermal Overload, 660	1	167982

ITEM	DESCRIPTION	QTY	PART #
D21	Boot, Thermal Overload Switch	1	167983
D22	Switch, 15A\125V Lighted Rocker	1	153421
D23	Rectifier, 40 Amp	1	153677
D24	Screw, 10-24 x 3/4 Fillister Head Machine	1	151750
D25	Wire-nut, 3/#16 AWG (Blue)	1	155492
D26	Tag, 660 Serial Number	1	156561
D27	Label, Caution Strip	1	155214
D28	Label, When Motor Cools...	1	154409
E	Frame	1	n/a
E1	Frame	1	153322
E2	Pan, Plastic	1	151736
E3	Plug, Water Drain	1	153439
E4	Plate, Adjustment	2	151758
E5	Pin, Rolled	2	151783
F	Guide Bar, 5/8 Dia.	1	151739-MK
F1	Bar, Guide, 5/8 Dia.	1	151739
F2	Cover, Guide Bar	1	151740
F3	Spacer, 5/8 Guide Bar Cover	2	151755
F4	Screw, 5/16-18 x 1 Hex Head Cap	2	151743
F5	Washer, 5/16 Split Lock	2	151747
F6	Washer, 5/16 SAE Flat	2	151754
G	Linear Bearing	1	151737-MK
G1	Casting, Bearing, Linear	1	151737
G1a	Bearing, Multi-Lube	2	157126
G2	Screw, 5/16-18 x 1 Hex Head Cap	2	151743
G3	Washer, 5/16 Split Lock	2	151747
G4	Washer, 5/16 SAE Flat	2	151754
H	Post	1	n/a
H1	Post, Rear, 660	1	153451
	Shaft, 5/8 Pivot, 660	1	153452
H2	Screw, 3/8-16 x 2 Hex Head Cap	2	153485
H3	Screw, 3/8-16 x 1 Hex Head Cap	1	152507
H4	Washer, 3/8 Split Lock	3	150925
H5	Washer, 3/8 SAE Flat	4	150923
H6	Knob, 3/8-16 x 1-1/2 MK Adjustment	1	156770-02
J	Roller Wheel	1	151756
J1	Bracket, Roller Wheel	1	154021
J2	Wheel, Roller	1	151799
J3	Screw, 1/4-20 x 1 1/2 Hex Head Cap	1	151914
J4	Washer, 1/4 SAE Flat	1	151915
J5	Nut, 1/4-20 Hex	1	151893
K	Table, 660	1	n/a
K1	Table, 660	1	152680
K2	Screw, 5/16-18 x 1 Hex Head Cap	2	151743
K3	Washer, 5/16 Split Lock	2	151747
K4	Washer, 5/16 SAE Flat	2	151754

ITEM	NUMBER	DESCRIPTION	
1.	158434	MK-225, 7 x 5/8 Arbor	
2.	139311	MK-215, 7 x 5/8 Arbor	
3.	153293	MK-315, 7 x 5/8 Arbor	
4.	134577-MK	Dual 45° Flat Angle Guide	
5.	134569-MK	90° Protractor	
6.	152792	Dressing Stone	
7.	152601	Ground Fault circuit Interrupter	
8.	153201-MK	45° Miter	
9.	151889	Saw Stand	

**ORDERING INFORMATION**

---

You may order MK Diamond products through your local MK Diamond distributor or, you may order direct from MK Diamond.

NOTE: There is a \$25.00 minimum order when ordering direct from MK Diamond. All purchases must be made using VISA, MasterCard or American Express.

When ordering direct from MK Diamond, please have the following information ready before calling:

- The Model Number of the saw
- The Serial Number of the saw
- Where the saw was purchased and when
- The Part Number for the part(s) being ordered
- The Part Description for the part(s) being ordered

All parts may be ordered by calling toll free to – 800 421-5830 or 310 539-5221 and asking for Customer Service. For technical questions, call – 800 474-5594.

**RETURN MATERIALS POLICY**

---

To expedite the service relative to the return of a product purchased through MK Diamond, please observe the following:

NOTE: When returning all items, they must have been purchased within the previous twelve (12) months.

- Have the Model Number of the saw
- Have the Serial Number of the saw
- Have the location of where the saw was purchased
- Have the date when the saw was purchased
- Contact Customer Service for approval to return the item(s)
- Obtain a Returned Goods Number (RGA) authorizing the return
- Follow the packaging instructions in the following section
- Ensure your item(s) are prepaid to the destination

For returned items, call toll free to – 800 421-5830 or 310 539-5221 and ask for Customer Service. For technical questions, call – 800 474-5594 or 310 257-2845.

**PACKAGING INSTRUCTIONS**

---

- Remove the Blade Guard and Support Angle Assembly
- Dry the saw before shipping
- When packing, include the following: MK-660 Saw, Diamond Blade, Blade Guard and Support Angle Assembly and adjustable Cutting Guide (Other accessories are not required)
- Package the unit in its original container or one of comparable size (do not ship the unit partially exposed)
- Ensure all parts are secured in the packaging to prevent moving

**AUTHORIZED SERVICE CENTERS**

---

For quicker repair time, you may contact MK Diamond Customer Service, toll free, at 800 421-5830 or 310 539-5221 for the Authorized Service Center closest too you or visit our web site at [www.mkdiamond.com](http://www.mkdiamond.com). For technical questions, call – 800 474-5594.









**MK-660 TILE SAW**  
OWNER'S MANUAL, PARTS LIST  
& OPERATING INSTRUCTIONS



**MK Diamond Products, Inc.**

MK Diamond Products, Inc.  
1315 Storm Parkway  
Torrance, CA 90501

Toll-Free: (800) 421-5830  
Phone: (310) 539-5221  
Fax: (310) 539-5158  
[www.mkdiamond.com](http://www.mkdiamond.com)