



Ermator

OPERATING INSTRUCTIONS

Dust Extractor

S36

**READ ALL INSTRUCTIONS BEFORE
USING**

Introduction

Dear Customer,

Thank you for choosing Ermator as your supplier.

We hope that the Ermator S36 dust extractor will be to your satisfaction and meet your expectations.

Ermator has been manufacturing professional dust extractors since 1966 and has over the years acquired a genuine technical knowledge in this area. We are continuously striving to improve our products in our product segment and will continue to supply the market with new equipment.

Notice!

These instructions are only for dust extractor type Ermator S36.

The Ermator S36 dust extractor can only be used with dry, non-explosive material.

The Ermator S36 dust extractor has been designed to clean construction areas and be connected to small electrical machines such as drills etc.

Ermator will not be held responsible if the dust extractor is used for other applications or been used in ways other than those outlined in this instruction manual.

Please pay particular attention to the safety regulations.

Read the complete instruction manual before using the Ermator S36.

All spare parts used with the Ermator S36 must be those specified by Ermator.

1. UNPACKING

When unpacking the machine, please check that the following accessories are included:

- The hose with end fittings.
- Handle.
- Floor nozzle.

If any of the above-mentioned parts are missing, please contact your local distributor or our sales representative.

Assemble the front wheels using the using bolt, washer and nut that are included in the package.

2. SAFTY INSTRUCTIONS

Handling

Warning

- Cables damaged through crushing or splitting can be dangerous if used and should be replaced immediately. Risk of personal injury.

Warning

- Do not connect the machine to an unearthed socket. Risk of personal injury.

Warning

- Make sure the assembly area is firm, so the dust extractor does not tip over. Risk of personal and material injury.
-

Warning

- Risk of pinching when handling the toggle fastener.

Warning

- The machine must not be used in environments where explosive gases may be present. Serious risk of explosion.

Service

Warning

- Remove the plug from the wall socket when carrying out maintenance work. Risk of personal injury.

Warning

- Dust can be spread when the coarse filter and the absolute filter are replaced that can be hazardous to health. Accordingly, the user should wear protective glasses, protective gloves, and a breathing mask conforming to protection class FFP3.

Warning

- Do not puncture the absolute filter. Risk of dust dispersion.

3. FUNKTION

The machine is designed for sucking and separating dry, non-combustible dust with an explosion limit value of $>0.1\text{mg}/\text{m}^3$.

The motor is started by the switch.

The switch has three positions: **0**: Motor off

1: Motor on

Dust-laden air is then sucked through the inlet valve at high speed via the suction hose. The air is slowed down by the cyclone and coarse dust particles are separated out, partly by centrifugal force and partly by gravity. Air and finer particles then pass through the double filter system where separation is made. The machine is designed for filter cleaning by reverse air pulse.

The separated dust accumulates in the cyclone until the machine is switched off, when it drops through the bottom flap into the plastic bag.

4. USE

Before use, the user must be trained in handling the machine and the hazardous dust.

WARNING

Connect the electric plug to a power outlet with the correct voltage, see the nameplate.

Connect the electric plug to an outlet with the correct voltage (see the designation plate).

The filter must be cleaned from time to time. This must be done before changing the plastic bag and can also be done when the work is complete or when there is poor suction.

Procedure: Cover the inlet, use attached cover, let the machine build up vacuum for a few seconds then quickly push down on the key and release it. Repeat the procedure 4-5 times.

Turn of the motor and wait until it stops completely, then uncover the inlet.

If suction remains poor, the filter should be replaced.

Only use original parts.

5. DUST STORAGE SYSTEM

S36 are equipped with a Longopac system for effective dust storage. This is a 20 m long plastic tube that will be divided into plastic bags using the striped attached with the machine.

To mount a new Longopac bag:

Release the belt holding the last bag. Remove the holder. Put in a new Longopac bag, pull out the inner end upwards. Mount the holder on to the machine and strap the upwards end with the belt. Pull down to outside end and close it using a stripe.

The machine can be used with original Ermator dust bag for single use.

Only change Longopac or bag after jet pulsing the filter

6. FILTER CHANGE

Risk of dust dispersion - Use of personal safety equipment

Unhealthy dust can be spread during filter change. Accordingly, the user should wear protective glasses, protective gloves, and a breathing mask conforming to protection class FFP3.

WARNING

Switch off the machine and pull the plug out of the socket.

Main filter

Loosen the 3 clamps and remove the top. Take the bag from the new filter.

Lift out the filter and place it gently in a plastic bag. This bag must be properly disposed.

Insert a new filter.

Only original filters may be used.

HEPA Filter

Loosen the two nuts on the filter cap carefully lift the filter into a clean plastic bag, use the bag from the new filter. This bag must be properly disposed. Insert a new filter in reverse order.

Check the seal when changing filters and change defective seals.

7. SERVICE

WARNING

Before cleaning and servicing the machine, you must switch the machine off and pull out the plug from the outlet.

- When cleaning and servicing the machine, you must switch off the machine and remove the plug from the socket.
- Avoid cleaning with a high pressure cleaner. If necessary, do not direct at the openings on the machine, especially the opening for cooling air.
- Before moving the machine from the work area, the machine must be cleaned.
- All other equipment must be regarded as contaminated and be treated thereafter.
- If possible, use a special suitable room.
- Proper personnel protective equipment must be used.
- All parts which are contaminated after service must be properly disposed of in plastic bags according to all regulations.
- If the machine has to be used for other purposes, it is extremely important that the machine is cleaned, to avoid the spread of hazardous dust.

Accessories

Part.no.	Description	No./machine
1376013	Longopac (4-pcs)	1 pcs
1276008	Bag (25-pcs) (optional)	1 pcs
200900051	Main filter	1 pcs
200700070a	HEPA 13 filter	3 pcs

For other spare parts, see the enclosed spare parts list.

8. WARRANTY

All Ermator devices and accessories have a 12-month factory warranty for material and manufacturing defects. The warranty extends to 36 months when returning the attached warranty slip. Do not attempt to repair the suction apparatus without the consent of the manufacturer.

The warranty does not cover defects which are the result of normal wear and tear, negligence, defective use, unauthorised repair or the suction apparatus being connected to the incorrect voltage. In the event of any complaint, the suction apparatus or an agreed part of it must be returned to us or our authorised representative for warranty examination and for any warranty repair or replacement.

9. PROBLEM SOLVING

The S36 is designed and manufactured for a severe environment and tasks, but the user must note that the machine must be protected from knocks and blows. Filter, seals, attachments, and connections are carefully adapted and selected with regard to the operator's work environment. Therefore, the operator and service personnel must treat the machine with care in order to work correctly for many years.

Problem	Cause	Procedure
Motor does not start	No power Cable defective Switch defective	Connect the machine Change Change
Motor stops immediately after starting	Wrong fuse	Connect to correct fuse
Motor runs but there is no suction	Hose not connected Hose blocked No Longopac bag	Connect hose Clean hose Fit Longopac bag
Motor runs but suction poor	Hole in the hose Filter blocked Top cover loose Sealing defective	Change hose Change filter Adjust Change current seal
Dust blows from motor	Filter loose or defective	Adjust or change
Abnormal noise		Order service

SAVE THESE INSTRUCTIONS!

TECHNICAL DATA

S36

VOLTAGE	230 VAC, 1-phase
POWER	3x1200 W max
MAX AIRFLOW	600 m ³ /h 387 cfm
MAX VACUUM	23 kPa
HOSE	10 m x Ø 63 mm 7,5 m x Ø 50 mm 33"x Ø 2,5" 25"x Ø 2,5"
INLET	Ø 63mm Ø 2,5"
MAIN FILTER	>99.5% 4,5 m ² /49,8ft ²
HEPA 13 FILTER	>99.95% 3st 3x1.2m ² /3x13,32ft ²
SOUND LEVEL	70 dB(A)
DUST STORAGE SYSTEM	Longopac system (440x600 mm)
DIMENSIONS LxWxH	840x620x1500 mm
WEIGHT	66 kg 145 lbs

S36 230 V

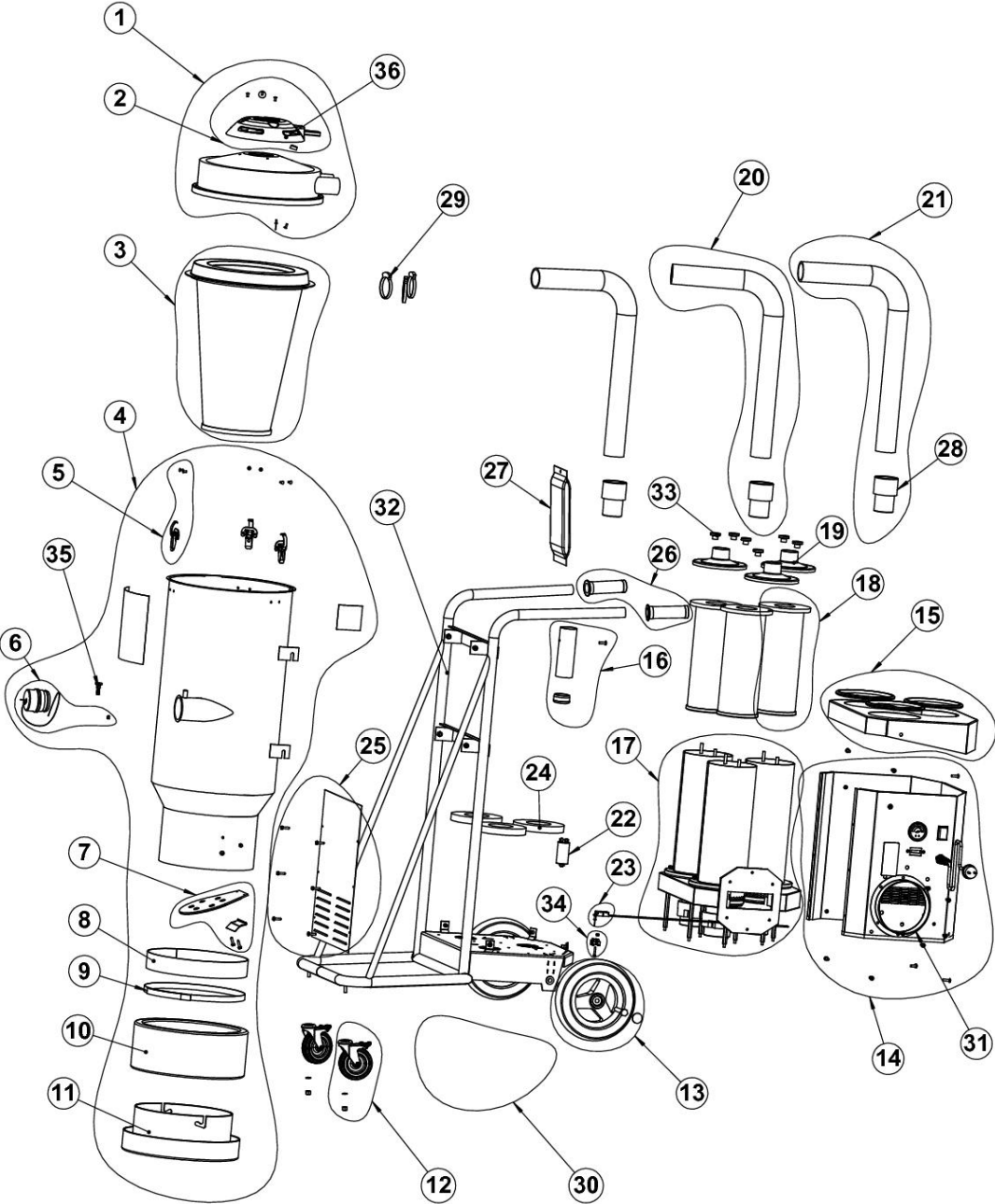

NUMBER	200900242	200900242a
MODEL	S36 230V	S36 230V 32 A OUTLET
REV.	01	

S36 230 V

POS.	QTY.	NUMBER	DESCRIPTION
1	1	201100160	TOP COVER PACKING (ex. S36)
2	1	201000118	CLEAN UNIT ASSEMBLY PACKING
3	1	200900051	FILTER
4	1	201000200a	TANK COMPLETE (ex. S36a)
5	3	200600799	HOLDER KIT
6	1	201000145	INLET SEAL COMPLETE SET
7	1	201000116	FLAP KIT
8	1	201100141	ANTI-SKID PACKING
9	1	201100140	BELT PACKING
10	1	1376013	LONGOPAC BAG 4 PACK
11	1	201100135	LONGOPAC HOLDER PACKING
12	1	200800152	FRONT WHEEL KIT
13	1	200800151	REAR WHEEL KIT
14	1	201100167	MOTOR COVER ASSEMBLY (ex. S36)
(14)	1	201100167a	MOTOR COVER ASSEMBLY (ex. S36 32 A OUTLET)
15	1	201000201	TOP MOTOR COVER KIT (ex.S36)
16	1	200800153	CLIP HOLDER KIT
17	1	201100169	MOTOR BOX KIT PACKING
18	3	200700070a	HEPA-FILTER
19	3	201000121	FILTER COVER KIT
20	2	201000203	MIDDLE HOSE KIT OF S36
21	1	201000204	HOSE KIT OF S36
22	1	201100158	ELECTRICAL FILTER
23	1	200700410	SOFT START 230V, KIT
24	3	201100161	INSULATION PACKING
25	1	201000205	PLATE COVER KIT OF MOTOR COVER
26	1	201000206	HANDLE KIT PACKING
27	1	95102	LONGOPAC SEAL CLIPS(60 PCS)
28	3	201100125	HOSE END (51MM) PACKING
29	3	201100137	HOSE CLAMP 60-65 PACKING
30	1	201000207	SCREW AND NUT SET OF S36
31	1	201000208	160MM EXHAUST AIR OUTLET PACKING
32	1	201000209	WAGON ASSEMBLY
33	6	201100128	KUNRLED THUMB NUT
34	1	201000210	CONNECTION BRIDGE KIT
35	1	201100139	LOCKING DEVICE PACKING
36	1	201000670	TOP COVER KIT ex. CLEAN UNIT

NUMBER	200900242	200900242a
MODEL	S36 230V	S36 230V 32 A OUTLET
REV.	01	

MOTOR BOX 230 V

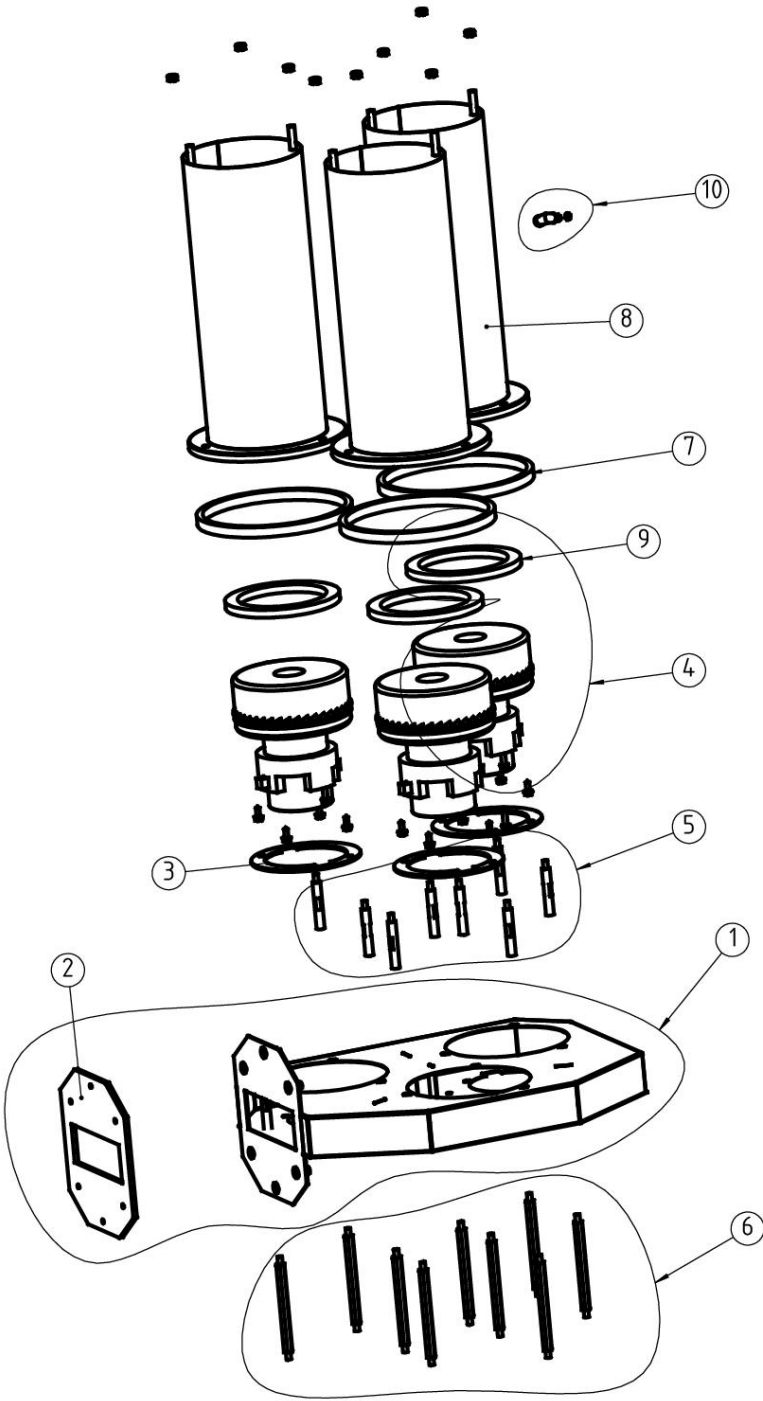

NUMBER	201100169
MODEL	MOTOR BOX ASSEMBLY
REV.	01

MOTOR BOX 230 V

POS.	QTY.	NUMBER	DESCRIPTION
1	1	201100171	MOTOR BOX (ex. S36)
2	1	201100172	SEALING 160 mm OUTLET
3	1	201100173	SEALING PACKING
4	3	200800060	MOTOR 230V KIT
5	1	201100174	UPPER SUPPORT PIN KIT (ex. S36)
6	1	201100175	LOWER SUPPORT PIN KIT (ex. S36)
7	1	201100170	TOP MOTOR SEALING
8	3	201100176	FILTER HOUSING
9	1	201100177	MOTOR SEALING KIT
10	1	201000178	NIPPLE ANGLE KIT

Number	201100169
Model	MOTOR BOX ASSEMBLY
Rev.	01

MOTOR COVER 230 V

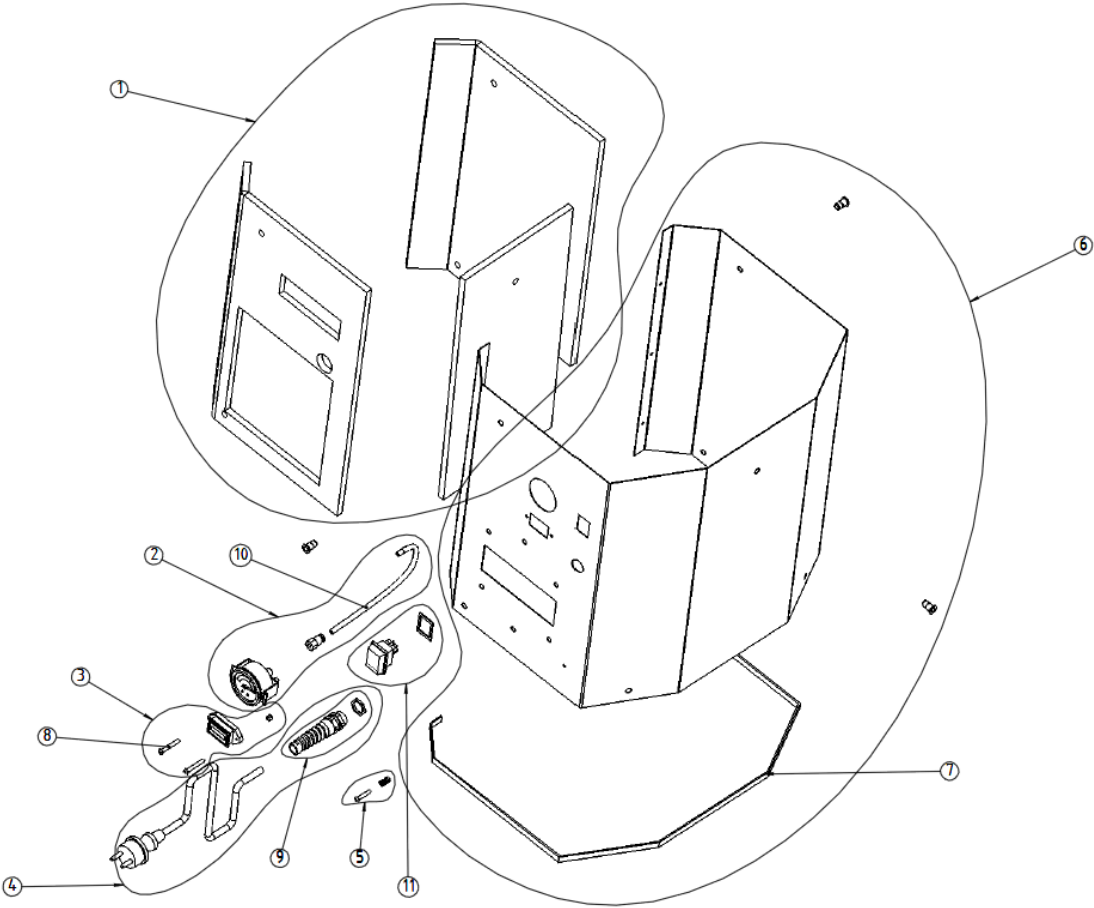

Number	201100167
Model	MOTOR COVER 230V
Rev.	01

MOTOR COVER 230 V

POS.	QTY.	NUMBER	DESCRIPTION
1	1	201100165	AC FOAM PACKING
2	1	200700413	MANOMETER KIT
3	1	201000133	COUNTER SET
4	1	201100149	CORD SET PACKING
5	1	201000211	GROUNDING SCREW KIT
6	1	201000212	MOTOR COVER
7	1	201100163	SEALING PACKING
8	2	201000213	SCREW SET OF COUNTER
9	1	201100150	CABLE FIX KIT (PG13)
10	1	201100164	HOSE PACKING
11	1	201100151	SWITCH PACKING

Number	201100167
Model	MOTOR COVER 230V
Rev.	01

MOTOR COVER 230 V 32 A OUTLET

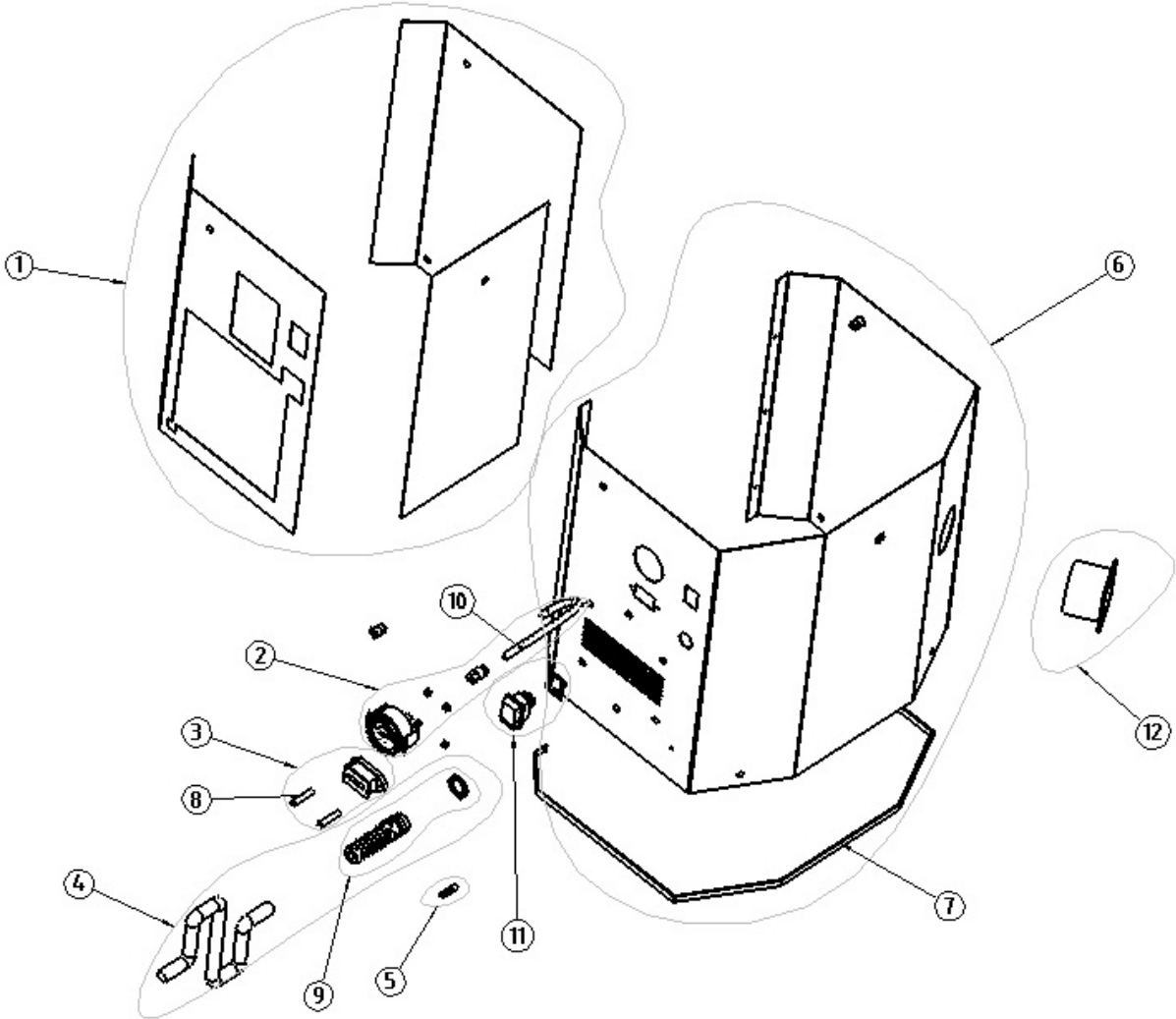

Number	201100167a
Model	MOTOR COVER (ex.S36 32A OUTLET)
Rev.	01

MOTOR COVER 230 V 32 A OUTLET

POS.	QTY.	NUMBER	DESCRIPTION
1	1	201100165	AC FOAM PACKING
2	1	200700413	MANOMETER KIT
3	1	201000133	COUNTER SET
4	1	201000705	CORD SET KIT (ex. S36 32A OUTLET)
5	1	201000211	GROUNDING SCREW KIT
6	1	201000212a	MOTOR COVER KIT (ex.S36a)
7	1	201100163	SEALING PACKING
8	1	201000213	SCREW SET OF COUNTER
9	1	201100706	STRAIN RELIEF
10	1	201100164	HOSE PACKING
11	1	201100151	SWITCH PACKING
12	1	201000666	ELECTRICAL OUTLET 30A

Number	201100167a
Model	MOTOR COVER (ex.S36 32A OUTLET)
Rev.	01

ACCESSORIES S36 230 V

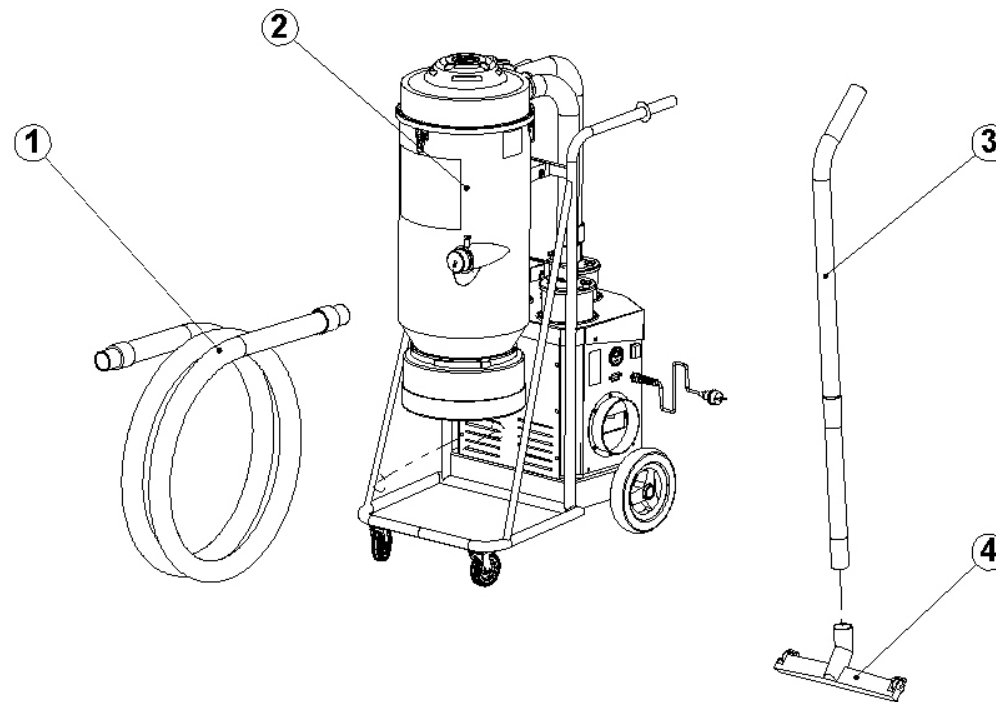

POS.	QTY	NUMBER	DESCRIPTION
1	1	201000128	HOSE 63mm x 10m (ex. S36)
(1)	1	201000061	HOSE 51mm x 7,5m (ex. S26)
2	1	N/A	
3	1	1224035	50S Steel tube Kit (2pc) dia 50
4	1	1326087	S450 Floor Tool 50mm x 450mm



Ermator