

# Operator's Manual

<b>Introduction</b> .....	<b>1</b>
<b>Safety</b> .....	<b>2</b>
Safety Alert Symbols .....	3
Fall Protection .....	3
Electrocution Hazard .....	4
Tip-over Hazards .....	5
Fall Hazards .....	6
Collision Hazards .....	6
Additional Safety Hazards .....	7
Battery Safety .....	7
<b>Jobsite Inspection</b> .....	<b>8</b>
<b>Functions Test</b> .....	<b>8</b>
<b>Operating Instructions</b> .....	<b>9</b>
Prestart .....	9
Starting Engine from Lower Control Panel .....	10
Starting Engine from Upper Control Box .....	11
Base Controls Operation and Test .....	12
Platform Control Operation and Test .....	13
Joystick Operation .....	14
Leveling Procedure .....	16
Shutdown Procedure .....	16
<b>Emergency Systems</b> .....	<b>17</b>
Emergency Stop .....	17
Emergency Lowering .....	17
<b>Fold Down Platform Railings</b> .....	<b>18</b>
<b>Machine Inspections</b> .....	<b>20</b>
Annual Inspection Report .....	24
<b>Maintenance</b> .....	<b>25</b>
Routine Maintenance .....	26
Scheduled Maintenance .....	26
Maintenance Safety .....	26
Lubrication .....	27
<b>Component Locations</b> .....	<b>28</b>
Full Machine .....	28
Modules .....	29
Upper Controls .....	30
Lower Controls .....	31
<b>Decals</b> .....	<b>32</b>
<b>Troubleshooting</b> .....	<b>34</b>
Serial Plate Location .....	35
Serial Plate Description .....	35
<b>Transport and Lifting Instructions</b> .....	<b>36</b>
Loading .....	36
Disengage Brakes before Towing or Winching .....	36
Engage Brakes before Driving .....	36
Lifting and Tie Down Instructions .....	38

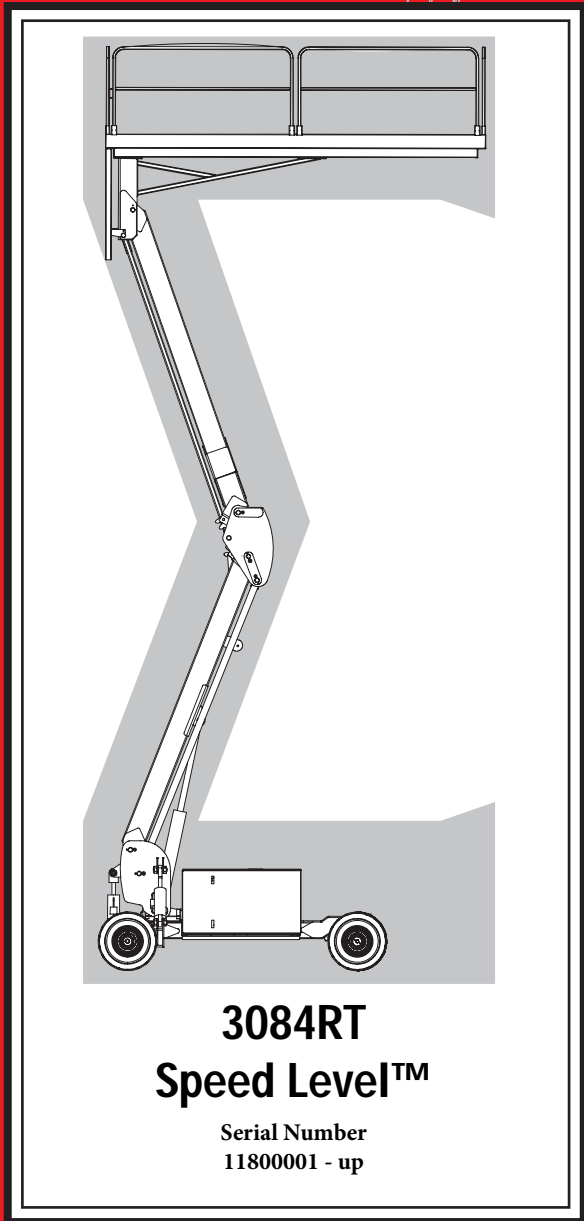

91857  
April 2009

# —Specifications—

<b>3084RT</b>		
<b>Working Height*</b>	<b>36 ft*</b>	<b>11.0 m*</b>
<b>Platform Height</b>	<b>30 ft</b>	<b>9.0m</b>
<b>Stowed Height</b>	<b>Rails Up</b>	<b>105 in</b>
	<b>Rails Folded Down</b>	<b>70 in</b>
<b>Maximum Number of Occupants</b>	<b>5</b>	<b>5</b>
<b>Lift Capacity (Evenly Distributed)</b>	<b>1500 lb</b>	<b>680 kg</b>
<b>Platform Dimensions</b>		
	<b>Length (inside rails)</b>	<b>14 ft</b>
	<b>Platform Width (inside rails)</b>	<b>72 in</b>
	<b>Guardrail Height</b>	<b>43.5 in</b>
	<b>Toeboard Height</b>	<b>6 in</b>
<b>Overall Length</b>	<b>14 ft 6 in</b>	<b>4.4 m</b>
<b>Overall Width</b>	<b>84 in</b>	<b>2.13 m</b>
<b>Wheel Base</b>	<b>100 in</b>	<b>2.54 m</b>
<b>Wheel Track</b>	<b>72.0 in</b>	<b>1.83 m</b>
<b>Turning Radius</b>	<b>Inside</b>	<b>8 ft 0 in</b>
	<b>Outside</b>	<b>16 ft 8 in</b>
<b>Ground Clearance</b>	<b>10 in</b>	<b>25 cm</b>
<b>Machine Weight** (Unloaded) (Approx.)</b>	<b>7200 lb**</b>	<b>3265 kg**</b>
<b>Drive System (Proportional)</b>		
	<b>Drive Speed (Platform Elevated)</b>	<b>0 – .75 mph</b>
	<b>Drive Speed (Platform Lowered)</b>	<b>0 – 4 mph</b>
<b>Lift/Lower Speed (Approx.)</b>	<b>30 sec / 40 sec</b>	<b>30 sec / 40 sec</b>
<b>Gradeability</b>	<b>45%</b>	<b>24.2°</b>
<b>Ground Pressure/Wheel (Maximum)</b>	<b>87 psi</b>	<b>6.1 kg/cm<sup>2</sup></b>
<b>Wheel Load</b>	<b>2610 lb</b>	<b>1186 kg</b>
<b>Tire Size-Standard</b>	<b>26 x 12D / 380NHS</b>	
<b>Tire Pressure, 12 Ply Pneumatic</b>	<b>45 psi</b>	<b>3.1 bar</b>
<b>Wheel Lug Nut Torque</b>	<b>75-85 ft/lb</b>	<b>102-115 Nm</b>
<b>Hydraulic Pressure</b>	<b>Main System</b>	<b>2800 psi</b>
	<b>Lift System</b>	<b>2800 psi</b>
	<b>Steer</b>	<b>2000 psi</b>
<b>Hydraulic Fluid Capacity</b>	<b>23 GAL</b>	<b>87 liters</b>
<b>Power Source</b>	<b>Kubota D752 Dual Fuel</b>	<b>Kubota 1105 Diesel</b>
<b>Fuel Capacity</b>	<b>15 GAL</b>	<b>57 liters</b>
<b>Leveling</b>	<b>Side to Side</b>	<b>14°</b>
	<b>Front to Rear</b>	<b>10°</b>
<b>Brakes</b>	<b>Multi-disc / Dual Rear Wheel</b>	
<p>Meets requirements of ANSI A92.6-2006 Section 4.  *Working height adds 6 feet (2 m) to platform height.  **Weight may increase with certain options or country standards.</p>		

# Introduction

---

This Operator's Manual has been designed to provide you, the customer, with the instructions and operating procedures essential to properly and safely operate your MEC Aerial Work Platform for its intended purpose of positioning personnel, along with their necessary tools and materials, to overhead work locations.



---

***The Operator's Manual must be read and understood prior to operating your MEC Aerial Work Platform. The user/operator should not accept operating responsibility until he/she has read and understands the operator's manual as well as having operated the MEC Aerial Work Platform under supervision of an authorized, trained and qualified operator.***

***It is essential that the operator of the aerial work platform is not alone on the workplace during operation.***

***Modifications of this machine from the original design and specifications without written permission from MEC are strictly forbidden. A modification may compromise the safety of the machine, subjecting operator(s) to serious injury or death.***

---

Your MEC Aerial Work Platform has been designed, built, and tested to provide safe, dependable service. Only authorized, trained and qualified personnel should be allowed to operate or service the machine.

MEC, as manufacturer, has no direct control over machine application and operation. Proper safety practices are the responsibility of the user and all operating personnel.

If there is a question on application and/or operation contact:



## **MEC Aerial Platform Sales Corp.**

1775 Park Street, Suite 77  
Selma, CA 93662  
USA

---

Phone: 1-800-387-4575  
559-891-2488

---

Fax: 559-891-2448

---

[www.mecAWP.com](http://www.mecAWP.com)

# Safety

---

**DO NOT operate this machine until you have read and understood the Safety section of this manual, have performed the Pre-Start Inspection, Routine Maintenance, and Functions Test, have inspected the jobsite for hazards, and have learned the operating procedures for this machine.**

Failure to read, understand and follow all safety rules, warnings, and instructions will unnecessarily expose you and others to dangerous situations. For your safety and the safety of those around you, you must operate your machine as instructed in this manual.

MEC designs aerial work platforms to be safe and reliable. They are intended to position personnel, along with their necessary tools and materials, to overhead work locations. The owner/user/operator of the machine should not accept responsibility for the operation of the machine unless properly trained.

ANSI A92.5 and other applicable standards identify requirements of all parties who may be involved with self-propelled elevating work platforms. The A92.5 Manual of Responsibilities is considered a part of this machine and can be found in the manual compartment, located at the platform control station. To ensure safe use of machine, inspections specified in Section 6.7 of ANSI A92.5-2006 must be performed at designated intervals as prescribed

Never perform service on the machine with the platform elevated without first blocking the boom assembly (see *Maintenance Safety* on page 26).

## **California Proposition 65 Warning**

---

This product contains chemicals known to the State of California to cause cancer and/or birth defects or other reproductive harm.

## Safety Alert Symbols

MEC manuals and decals use symbols and colors to help you recognize important safety, operation and maintenance information.



**RED** – Indicates an imminently hazardous situation which, if not avoided, will result in death or serious injury.



**ORANGE** – Indicates a potentially hazardous situation which, if not avoided, could result in death or serious injury.



**YELLOW with alert symbol** – Indicates a potentially hazardous situation which, if not avoided, may result in minor or moderate injury.



**YELLOW without alert symbol** – Indicates a potentially hazardous situation which, if not avoided, may result in property damage.

## Fall Protection

Operators must comply with employer, job site and governmental rules regarding the use of personal protective equipment.

*If required by your employer or job site*, use personal fall protection equipment (PFPE) when operating this machine.

All PFPE must comply with applicable governmental regulations, and must be inspected and used in accordance with the PFPE manufacturer's instructions.

**ALWAYS** wear an approved fall restraint properly attached to a designated anchorage point when driving or operating the machine. Attach only one fall restraint to each anchorage point.

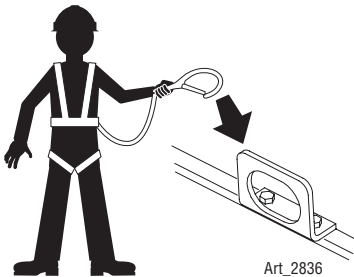

## Electrocution Hazard



**ELECTROCUTION HAZARD!!! THIS MACHINE IS NOT INSULATED!**

**DEATH OR SERIOUS INJURY will result from contact with or inadequate clearance from any electrically charged conductor.**

**You must maintain a CLEARANCE OF AT LEAST 10 FEET (3.05 m) between any part of the machine, or its load, and any electrical line or apparatus carrying over 300 Volts up to 50,000 Volts. One foot (30.5 cm) additional clearance is required for every additional 30,000 Volts.**

**Observe Minimum Safe Approach Distance.**

DO NOT work in close proximity to, or in contact with, energized power lines and electrical equipment. This machine is not insulated and WILL NOT protect the operator from injury or the machine from damage.

Refer to Table and all applicable governmental regulations for the minimum safe distances from energized power lines and electrical equipment.



ART\_3070



ART\_3060

### Minimum Safe Approach Distance

Voltage Phase to Phase	Minimum Safe Approach Distance	
	Feet	Meters
0 to 300 Volts	Avoid Contact	
Over 300V to 50kv	10	3.05
Over 50KV to 200KV	15	4.60
Over 200KV to 350KV	20	6.10
Over 350KV to 500KV	25	7.62
Over 500KV to 750KV	35	10.67
Over 750KV to 1000KV	45	13.72

**DO NOT touch the machine if it contacts energized power lines.**

Personnel in the platform:

- Move away from the platform rails,
- DO NOT attempt to operate the machine, and
- DO NOT touch any part of the machine until energized power lines are shut off.

Personnel on the ground:

- DO NOT approach the machine and
- DO NOT touch or attempt to operate the machine until energized power lines are turned off.

Do not operate the machine during electrical storms or lightning.

DO NOT use the machine as a ground for welding unless properly equipped with a weld line to platform option.

## Tip-over Hazards



ART\_3065  
**DO NOT OVERLOAD**

DO NOT exceed the maximum platform capacity (see Specifications). The weight of options and accessories will reduce the rated platform capacity and must be factored into the total platform load. Refer to the decals on the options.

DO NOT elevate the platform when the machine is on a surface that is soft, non-planar, or exceeds the leveling range of the machine.

The tilt alarm will sound when the machine is off level. If the alarm sounds when the platform is lowered, DO NOT attempt to elevate the platform. Carefully lower, re-level the machine, or move the machine to a surface within the leveling range.

If the alarm sounds when the platform is raised, use extreme caution to lower the platform.

**Driving in stowed position:** use extreme care and slow speeds when driving across uneven terrain, debris, unstable or slippery surfaces, and near holes or drop-offs.

**Driving with the platform elevated:** DO NOT drive on or near uneven terrain, unstable surfaces or other hazardous conditions.

DO NOT push off or pull toward any object outside the platform.



ART\_3064  
**DO NOT ELEVATE OR DRIVE ELEVATED ON A SURFACE THAT EXCEEDS THE LEVELING RANGE**

### Maximum Allowable Side Force

ANSI and CSA	CE and AUS
250 lbs (1100 N)	90 lbs (400 N)

DO NOT elevate the platform when wind speeds are in excess of 28 m.p.h. (12.5 m/s). If these wind speeds occur when the platform is elevated, carefully lower and discontinue operation.

DO NOT increase the surface area of the platform (i.e. cover the rails with tarp or plywood). Increased surface area exposed to the wind will decrease machine stability.

DO NOT attach overhanging loads or use the machine as a crane.

DO NOT transport tools and materials unless they are evenly distributed and can be safely handled by personnel in the platform. Secure all tools and loose materials to prevent injury to personnel below the platform.

DO NOT alter or disable machine components that may affect safety and stability.

DO NOT replace items critical to machine stability with items of different weight or specification.

DO NOT modify or alter the work platform without written permission from MEC, as modifications can increase weight and/or surface area resulting in instability.

DO NOT place ladders or scaffolds in the platform or against any part of the machine.

DO NOT use the machine on a moving or mobile surface or vehicle.

Ensure that all tires are in good condition, air filled tires are properly inflated and lug nuts are properly torqued.



ART\_3063  
**DO NOT DRIVE ON IRREGULAR OR UNSTABLE SURFACE**



ART\_3069  
**DO NOT PUSH OR PULL OBJECTS OUTSIDE PLATFORM**



ART\_3071  
**DO NOT ELEVATE IN WINDY CONDITIONS**



ART\_3059  
**DO NOT USE AS CRANE**

## Fall Hazards



DO NOT sit, stand or climb on the platform guard rails. Maintain a firm footing on the platform floor at all times.

DO NOT exit the platform when elevated

DO NOT climb down from the platform when elevated.

Keep the platform floor clear of debris.

DO NOT fasten a fall restraint lanyard to an adjacent structure.

Ensure that the entry is properly closed before operating the machine.

Operators must comply with employer, job site and governmental rules regarding the use of personal protective equipment.

## Collision Hazards



Be aware of blind spots while operating this machine.

Watch for overhead obstructions when elevating the platform.

Watch for crushing hazards when holding the platform rail.

Reduce travel speed when moving the machine on slopes, when near personnel and obstacles, or when surface conditions are wet, slippery or otherwise limiting.

DO NOT operate in the path of any crane unless the controls of the crane have been locked out and/or precautions have been taken to prevent any possible collision.

Stunt driving and horseplay are PROHIBITED.



## Additional Safety Hazards

---

### Explosion and Fire Hazards

---

DO NOT operate the machine in hazardous locations or locations where potentially flammable or explosive gasses or particles may be present.

### Damaged Machine Hazards

---

Conduct a thorough pre-start inspection of the machine and test all functions before each work shift to check for damage, malfunction and unauthorized modification. Tag and remove a damaged, malfunctioning or modified machine from service. DO NOT use a damaged, malfunctioning or modified machine.

Routine maintenance must be performed by the operator before each work shift. Scheduled maintenance must be performed by a qualified service technician at scheduled intervals. Tag and remove from service any machine that has not had scheduled preventative maintenance performed.

Check that all safety and instructional decals are in place and undamaged.

Check that the operator's, safety and responsibilities manuals are present in the storage container located in the platform. All manuals must be complete, undamaged and readable.

### Bodily Injury Hazards

---

DO NOT operate the machine when there is a hydraulic fluid or air leak. Hydraulic fluid or air under pressure can penetrate and/or burn skin.

All compartments must remain closed and secure during machine operation. Improper contact with components under any cover will cause serious injury. Only trained maintenance personnel should access compartments. The operator should only access a compartment when performing pre-operation inspection.

### Weld Line to Platform Safety (if equipped)

---

Read, understand and follow all warnings and instructions provided with the welding power unit.

DO NOT connect weld leads or cables unless the welding power unit is turned off at the platform controls.

DO NOT operate unless the weld cables are properly connected.

## Battery Safety

---

### Burn Hazards

---

Batteries contain acid. Always wear protective clothing and eye wear when working with batteries.

Avoid spilling or contacting battery acid. Neutralize battery acid spills with baking soda and water.

### Explosion Hazard

---

Keep sparks, flame and lighted tobacco away from batteries. Batteries emit explosive gas.

### Electrocution Hazard

---

Avoid contact with electrical terminals.

## Jobsite Inspection

---

**DO NOT operate this machine until you have read and understood the Safety section of this manual, have performed the Pre-Start Inspection, Routine Maintenance, and Functions Test, have inspected the jobsite for hazards, and have learned the operating procedures for this machine.**

Inspect the jobsite and determine whether the jobsite is suitable for safe machine operation. Do this before moving the machine to the jobsite.

Be aware of changing jobsite conditions, and continue to watch for hazards while operating the machine.

Operators must comply with employer, job site and governmental rules regarding the use of personal protective equipment – see “Fall Protection” on page 3.

### Workplace Inspection

---

Check the jobsite where the machine will be used for all possible hazards, including but not limited to:

- drop-offs or holes, including those concealed by water, ice, mud, etc.
- unstable or slippery surfaces
- bumps, surface obstructions and debris
- overhead obstructions and electrical conductors
- hazardous locations and atmospheres
- inadequate surface and support to withstand all load forces imposed by the machine
- wind and weather conditions
- the presence of unauthorized personnel
- other possible unsafe conditions

## Functions Test

---

**DO NOT operate this machine until you have read and understood the Safety section of this manual, have performed the Pre-Start Inspection, Routine Maintenance, and Functions Test, have inspected the jobsite for hazards, and have learned the operating procedures for this machine.**

The operator must conduct a Functions Test of the machine before each work shift to check that all machine systems are working properly.

Test the machine on a firm level surface with no debris, drop-offs, potholes or overhead obstructions. Perform each test outlined in *Operating Instructions* before using the machine.

DO NOT use a machine that is malfunctioning. If any function does not perform as described, tag the machine and remove for repair by a qualified service technician. After repairs are completed, a Pre-Start Inspection and Functions Test must be performed before using the machine.

# Operating Instructions

**DO NOT operate this machine until you have read and understood the Safety section of this manual, have performed the Pre-Start Inspection, Routine Maintenance, and Functions Test, have inspected the jobsite for hazards, and have learned the operating procedures for this machine.**

This section provides instructions for each function of machine operation. Follow all safety rules and instructions.

This machine may be operated by trained and authorized personnel only. If multiple operators use this machine, all must be qualified and authorized to use it. New operators must perform a Pre-Start Inspection (see page 21) and Functions Test prior to operating the machine.

Operators must comply with employer, job site and governmental rules regarding the use of personal protective equipment – see “Fall Protection” on page 3.

## Prestart

- Perform *Prestart Inspection* (see page 21).
- Check base control EMERGENCY STOP switch – turn clockwise to reset.

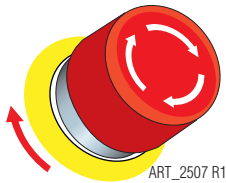
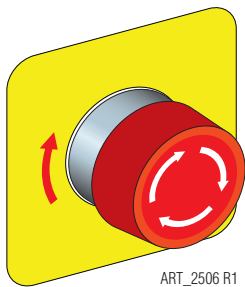

- Check platform control EMERGENCY STOP switch – turn clockwise to reset.

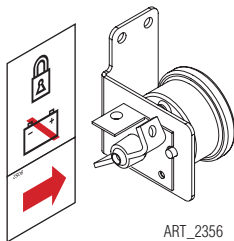

- Check Battery Disconnect switch in control module next to lower control box. Must be in ON position.

## Starting Engine from Lower Control Panel

Be sure that the upper and lower EMERGENCY STOP Switches are reset.

- **Upper Control Box:** Turn Engine Start Switch to RUN.

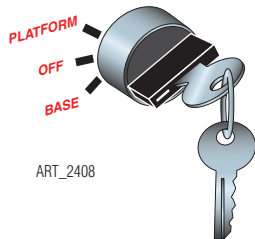
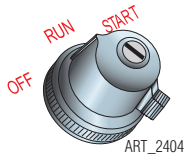

- **Lower Control Box:** Turn key switch to BASE.

## Dual Fuel Engine

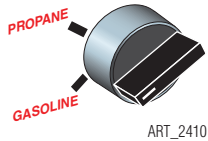

Fuel selection can be made before starting the engine or while engine is running. If fuel selection is made while engine is running, only a *minor* hesitation should occur.

- Turn the Fuel Selector Switch to the desired fuel, GASOLINE or PROPANE.

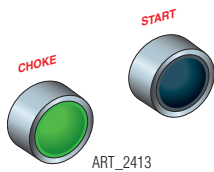

- Press and hold the START button - release the button when the engine starts.

**Note:** Cold starts may require the CHOKe button to be pressed while pressing the START button.

**CAUTION—PREVENT STARTER DAMAGE:**

*Maximum cranking time is 10 seconds. Wait 35 seconds between starting attempts. Failure to start after multiple attempts indicates possibility of another problem.*

## Diesel Engine



- Press and hold the START button - release the button when the engine starts.
- **Cold Start:** press and hold the GLOW button as indicated in the Preheat table.
- With the GLOW Button held press and hold the START Button until the engine starts.
- Release both buttons once the engine starts.

**Preheat Table**

Ambient Temperature	Preheat Time
Above 50°F (10°C)	5 Seconds
23°F to 50°F (-5°C to 10°C)	10 Seconds
Below 23°F (-5°C)	20 Seconds
20 Seconds = Maximum Limit of Preheat time	

**CAUTION—PREVENT STARTER DAMAGE:**

*Maximum cranking time is 10 seconds. Wait 35 seconds between starting attempts. Failure to start after multiple attempts indicates possibility of another problem.*

## Starting Engine from Upper Control Box

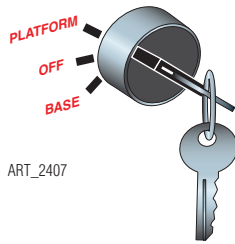

- **Lower Control Box:** Turn the Key Switch to PLATFORM.

## Dual Fuel Engine

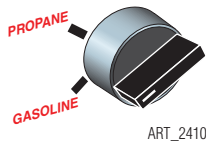

- **Lower Control Box:** Turn the Fuel Selector Switch to the desired fuel, GASOLINE or PROPANE.

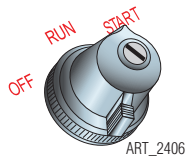

- **Upper Control Box:** Turn the Engine Start Switch to START - release when the engine starts.



**Note:** Cold starts may require the CHOKE Switch be lifted and held while turning the START Switch.

### **CAUTION—PREVENT STARTER DAMAGE:**

*Maximum cranking time is 10 seconds. Wait 35 seconds between starting attempts. Failure to start after multiple attempts indicates possibility of another problem.*

## Diesel Engine

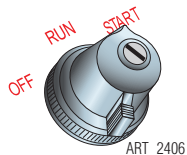

- **Upper Control Box:** Turn the Engine Start Switch to START - release when the engine starts.



- **Cold Start:** lift and hold the GLOW Switch as indicated in the Preheat table.
- With the GLOW Switch held, turn the START Switch until the engine starts.
- Release both switches once the engine starts.

### Preheat Table

Ambient Temperature	Preheat Time
Above 50°F (10°C)	5 Seconds
50°F to 23°F (10°C to -5°C)	10 Seconds
Below 23°F (-5°C)	20 Seconds
20 Seconds = Limit of Preheat time	

### **CAUTION—PREVENT STARTER DAMAGE:**

*Maximum cranking time is 10 seconds. Wait 35 seconds between starting attempts. Failure to start after multiple attempts indicates possibility of another problem.*

## Base Controls Operation and Test

**IMPORTANT**—Be sure the area above the machine is clear of obstructions to allow full elevation of platform.

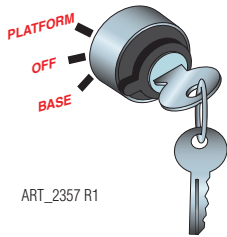

### Select BASE Operation

- Turn the selector switch to BASE.

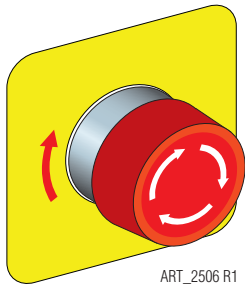

### Emergency Stop

- Press the EMERGENCY STOP switch at any time to stop all machine functions.
- Turn switch *clockwise* to reset.



**Do not elevate the platform if the machine is not on a firm level surface.**

### Elevate Platform

- Press and hold the RAISE button on the base control panel to elevate the platform.

#### Test Operation

- Elevate to maximum height.
- Releasing the button will stop elevation.
- Pressing the EMERGENCY STOP switch will stop elevation.

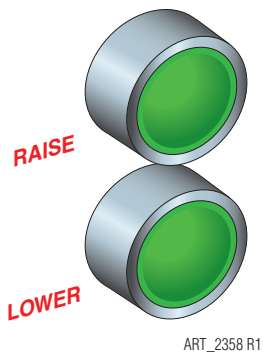

### Lower Platform

- Press the LOWER button. Release when the desired platform height is reached.

#### Test Operation

- Lower the platform.
- Releasing the button will stop descent.
- Pressing the EMERGENCY STOP switch will stop descent.

## Platform Control Operation and Test

**IMPORTANT**—Check that the route of travel to be taken is clear of persons, obstructions, debris, holes, and drop offs, and is capable of supporting the machine.

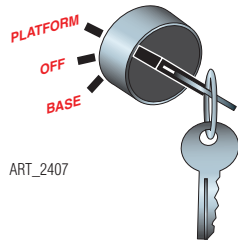

### Select PLATFORM Operation

- **Lower Control Box:** Turn the selector switch to PLATFORM.

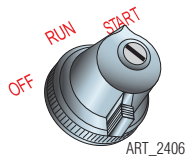

### Operate from Platform

- Enter the platform and close and secure the entry.
- Turn the Engine Start Switch to start the engine.
- If equipped, press the Horn Button to verify proper operation.



### Emergency Stop

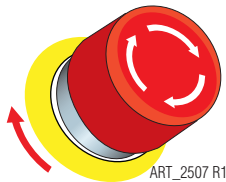

- Press the EMERGENCY STOP switch at any time to stop all machine functions.
- Turn switch *clockwise* to reset.

#### **!** WARNING

**Activation of the EMERGENCY STOP switch will apply brakes immediately. This may cause unexpected platform movement as the machine comes to a sudden stop. Brace yourself and secure objects on the platform during operation of machine.**

## Joystick Operation

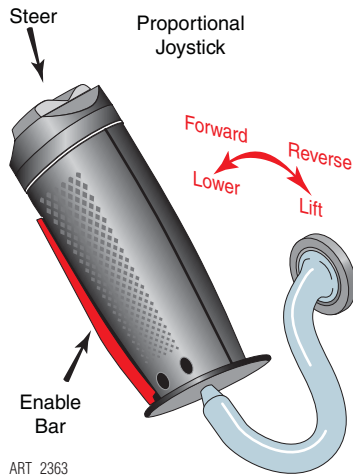

- Function speed is proportional and is controlled by the movement of the joystick.
- The further it is moved forward, the faster the speed will be.
- The joystick returns to the neutral (center) position when released.

### WARNING

**Do not elevate platform unless guardrails are installed and secure – see “Fold Down Platform Railings” on page 18.**

**If the platform fails to lower DO NOT attempt to climb down the elevating assembly. Serious injury may result – see “Emergency Systems” on page 17.**

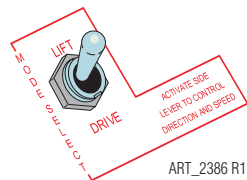

## Elevate Platform

- Place the MODE SELECT switch in the LIFT position.
- Squeeze the enable bar and move the joystick toward you.

### Test Operation

- Rate of lift is proportional and is dependent on the movement of the joystick.
- Elevate to maximum height.
- Releasing the enable bar or the joystick will stop elevation.
- Pressing the EMERGENCY STOP switch will stop elevation.

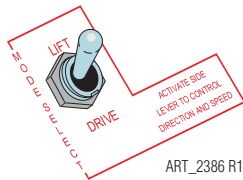

## Lower Platform

- Place the MODE SELECT switch in the LIFT position.
- Move the joystick away from you.

### Test Operation

- Rate of descent is fixed - platform lowers at same rate regardless of handle position.
- Pressing the EMERGENCY STOP switch will stop descent.

### WARNING

**Check that the route is clear of persons, obstructions, debris, holes and drop-offs, and is capable if supporting the machine.**

**IMPORTANT**—Always check front steer wheel direction before driving.

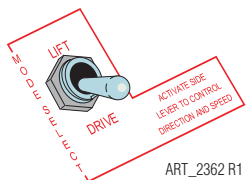

## Steering

- Place the MODE SELECT switch in the DRIVE position.
- Squeeze the Enable Bar.
- Press the Steering Switch with your thumb to steer left or right.

### Test Operation

- Releasing the Enable Bar or Steering Switch will stop steering function.
- The steer wheels do not automatically center after a turn. The steer wheels must be returned to the straight-ahead position with the steering switch.



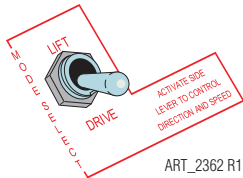
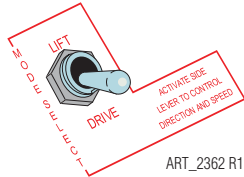
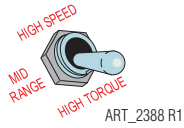

## Drive Torque (Speed Control)

Drive speed is selectable until the platform is elevated above 10 Feet (3 m). When the platform is elevated the machine defaults to MID RANGE and the switch is locked-out (non functioning).

- HIGH SPEED: allows speeds up to 3 m.p.h. (4.8 km/h).
- MID RANGE: allows speeds up to 0.4 m.p.h. (0.6 km/h).
- HIGH TORQUE: use to drive up or down a slope that is too steep for normal speed.

## Drive Forward

- Place the MODE SELECT switch in the DRIVE position.
- Squeeze the enable bar and move the joystick away from you.

### Test Operation

- Drive speed is proportional and is dependent on the movement of the joystick.
- Releasing the enable bar or returning the joystick to the center position will stop drive.
- Pressing the EMERGENCY STOP switch will stop drive.

## Drive Reverse

- Place the MODE SELECT switch in the DRIVE position.
- Squeeze the enable bar and move the joystick toward you.

### Test Operation

- Drive speed is proportional and is dependent on the movement of the joystick.
- Releasing the enable bar or returning the joystick to the center position will stop drive.
- Pressing the EMERGENCY STOP switch will stop drive.

## Brake

- For parking, the brake is automatically applied when the joystick is positioned in the neutral (center) position.

## Leveling Procedure



Leveling of the machine can only be performed when the platform height is below the Stowed Height Limit Switch setting of approximately 10 feet (3 m).

If the TILT light is *ON*, the platform must be brought to level or the LIFT function will not operate.

When operating on a sloped surface, the platform can be brought to level using the AUTO LEVEL switch or the MANUAL LEVEL switches.



**Do Not drive elevated across uneven terrain (see Tip-over Hazards on page 5).**

**Note:** The TILT light must be *OFF* or the platform will not elevate.

### Auto Level

- Move the toggle switch *DOWN* to start leveling.
- Hold the toggle switch *DOWN* until leveling operation is complete.
  - When the platform reaches the level position, the TILT light will turn *OFF* and the machine will stop correcting.

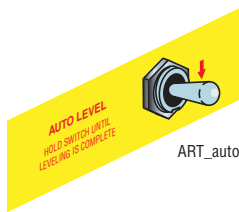

### Manual Level: Front to Rear

- **Tilt to Front:** Move and hold the toggle switch to the *LEFT* to tilt the platform to the desired position.
- **Tilt to Rear:** Move and hold the toggle switch to the *RIGHT* to tilt the platform to the desired position.

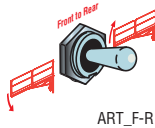

### Manual Level: Side to Side

- **Tilt to Left:** Move and hold the toggle switch to the *LEFT* to tilt the platform to the desired position.
- **Tilt to Right:** Move and hold the toggle switch to the *RIGHT* to tilt the platform to the desired position.

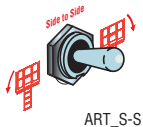

## Shutdown Procedure

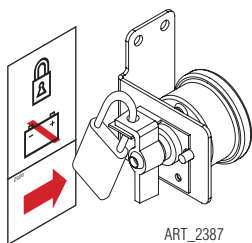

- When finished with the machine, place the platform in the stowed position.
- Park the machine on a level surface.
- Turn the key switch to the OFF position and remove the key to prevent unauthorized use.
- Carefully exit the platform using a constant three (3) point dismount/grip.
- Turn the battery disconnect switch to the OFF position.

**Note:** Leaving the battery disconnect switch in the ON position for an extended time will drain the battery.

- Put a padlock on the battery disconnect switch to prevent unauthorized operation.

# Emergency Systems



**WARNING**

**If the control system fails while the platform is elevated, have an experienced operator use the emergency lowering procedure to safely lower the platform.**

**Do not attempt to climb down elevating assembly.**

## Emergency Stop

The machine is equipped with an EMERGENCY STOP switch on both control panels.

- Press the EMERGENCY STOP switch at any time to stop all machine functions.
- Turn switch *clockwise* to reset.

### Selector Switch set to PLATFORM

- Either switch will stop all machine functions.
- Both switches must be reset or machine will not operate.

### Selector Switch is set to BASE

- The upper controls are locked out.
- The lower switch must be reset or the machine will not operate.
- The machine will operate from the lower controls if the upper controls switch is tripped.

## Emergency Lowering

The Emergency Lowering System is used to lower the platform in case of power or valve failure. The Emergency Lowering switch will function if the EMERGENCY STOP switch is tripped.

To lower the platform, perform the following steps:

- Push and hold the toggle switch down to lower the platform.
- Once the platform is fully lowered, release the toggle switch.

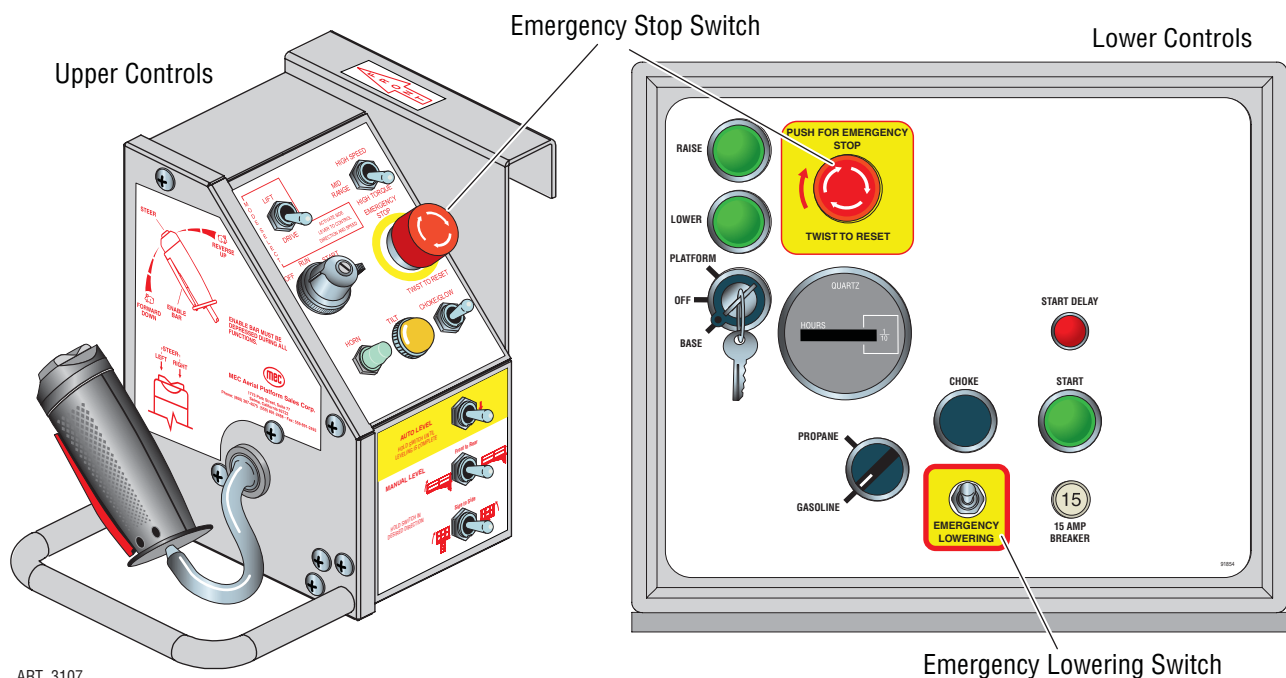

ART\_3107

# Fold Down Platform Railings

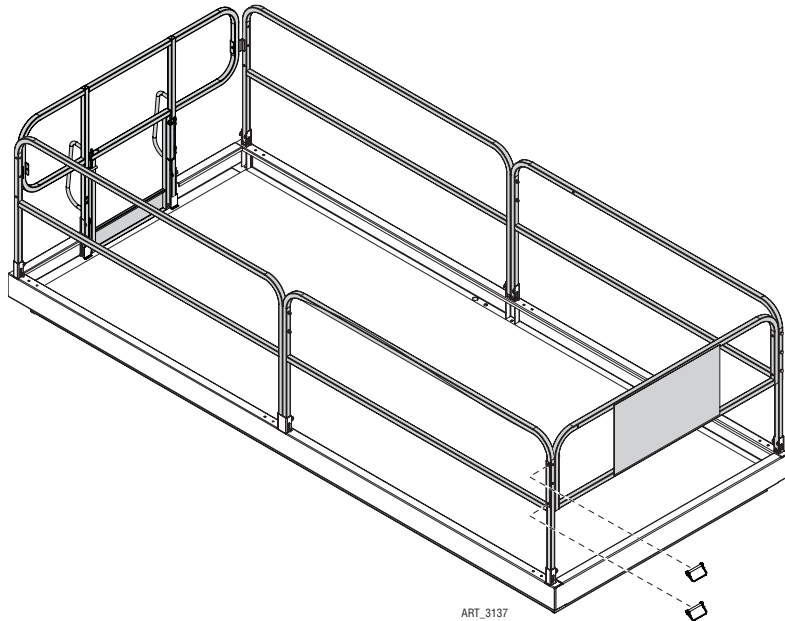

## 1 Open the Loading Gate

- Remove the 2 snap pins that hold the loading gate to the side guardrail.

## 2 Secure the Loading Gate

Swing the siloading gate open

- Secure the gate to the side guardrail using 1 of the 2 snap pins.
- Return the other snap pin to its place.

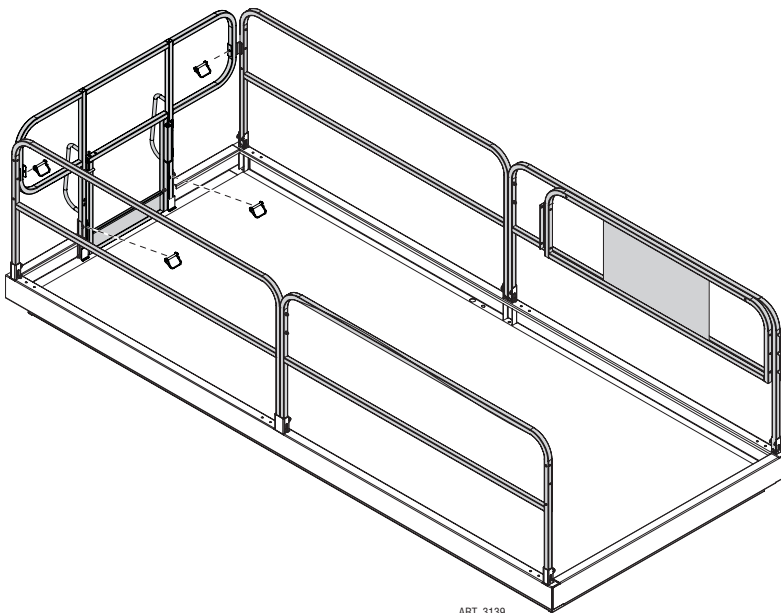
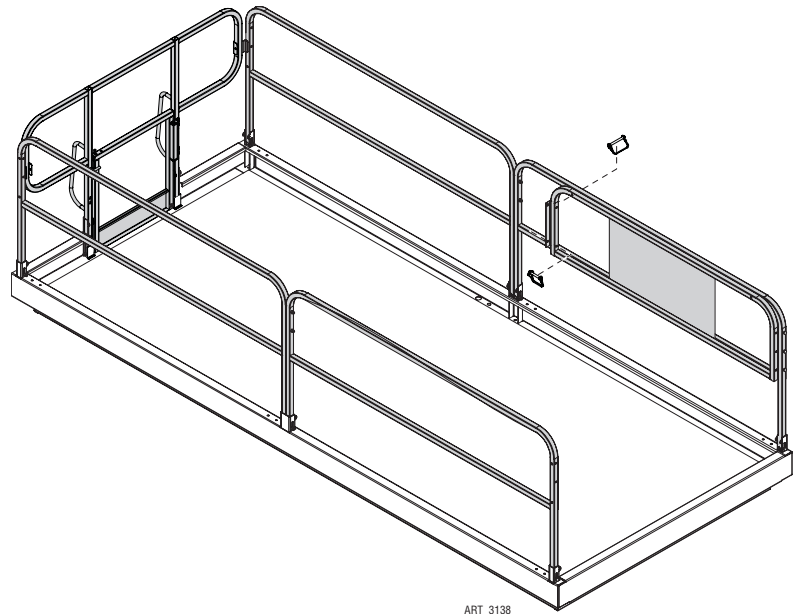

## 3 Release the Entry Rail

- Remove the 2 snap pins from the top corners of the entry guardrail.
- Remove the 2 snap pins from the base of the entry guardrail.

continued...

## Fold Down Rails (continued)

### 4 Lower the Entry Rail

- Lower the entry guardrail to the platform floor.
- Return the snap pins to their places.

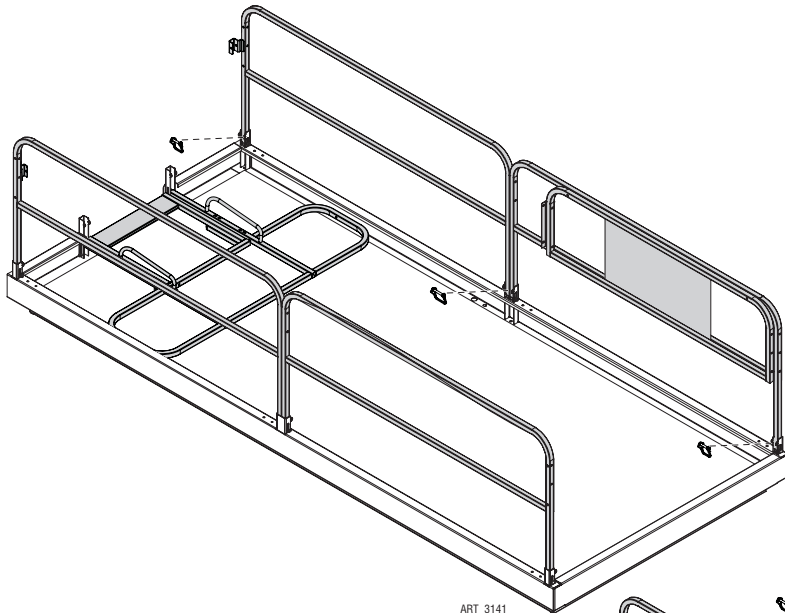
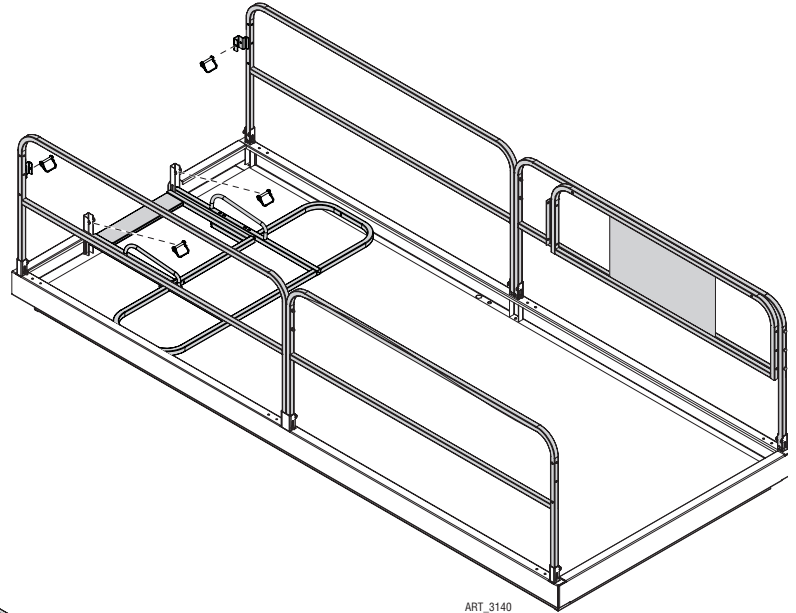

### 5 Release Left Side Rail

- Remove the 3 snap pins from the base the guardrail with the loading gate.

### 6 Lower Left Side Rail

- Lower the guardrail and loading gate to the platform floor.
- Return the snap pins to their places.

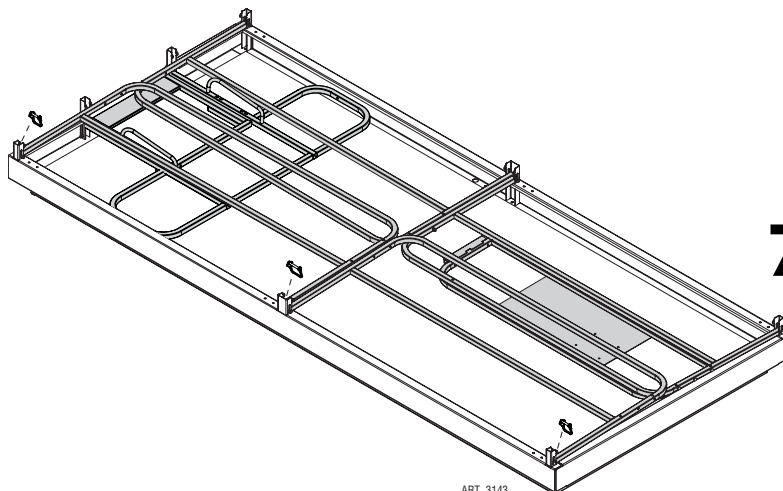
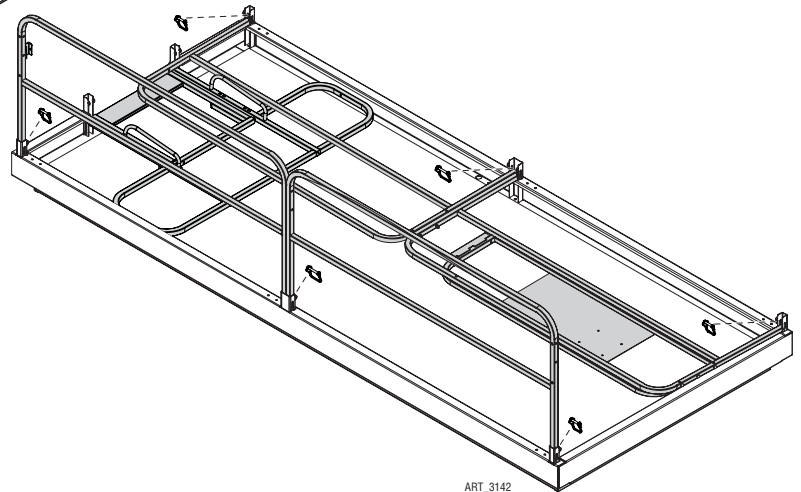

### 7 Release and Lower Right Side Rail

- Remove the 3 snap pins from the base of the right side guardrail.
- Lower the guardrail to the platform floor.
- Return the snap pins to their places.

Reverse the procedure to erect the guardrails.

# Machine Inspections

---

**DO NOT** operate this machine until you have read and understood the Safety section of this manual, have performed the Pre-Start Inspection, Routine Maintenance, and Functions Test, have inspected the jobsite for hazards, and have learned the operating procedures for this machine.

The operator must conduct a thorough Pre-Start Inspection of the machine and test all functions before each work shift to check for damage, malfunction and unauthorized modification.

Tag and remove a damaged, malfunctioning or modified machine from service. **DO NOT** use a damaged, malfunctioning or modified machine.

Use the Pre-Start Inspection to determine what Routine Maintenance is required. The operator may perform only the routine maintenance items specified in this manual.

**IMPORTANT**— Scheduled maintenance inspection checklists are included in this manual for use only by qualified service technicians. Only qualified service technicians may perform repairs to the machine. After repairs are completed, the operator must perform a Pre-Start Inspection before proceeding to the Functions Test.



---

***Never perform service on the machine with the platform elevated without first blocking the elevating assembly (see Maintenance Safety on page 26).***

***Never leave hydraulic components or hoses open. They must be protected from contamination (including rain) at all times.***

***Never open a hydraulic system when there are contaminants in the air.***

***Always clean the surrounding area before opening hydraulic systems.***

***Use only recommended lubricants. Improper lubricants or incompatible lubricants may be as harmful as no lubrication.***

***Watch for makeshift “fixes” which can jeopardize safety as well as lead to more costly repair.***

---



---

***Hydraulic fluid under pressure can penetrate and burn skin, damage eyes, and may cause serious injury, blindness, and even death. Correct leaks immediately.***

---



---

***Failure to perform preventive maintenance at recommended intervals may result in the unit being operated with a defect that could result in injury or death of the operator.***

***Immediately report to your supervisor any Defect or malfunction. Any defect shall be repaired prior to continued use of the aerial work platform.***

***Inspection and maintenance should be performed by qualified personnel familiar with the equipment. Fluid leaks under pressure may not always be visible. Check for pin hole leaks with a piece of cardboard, not your hand.***

---

## Pre-Start Inspection Checklist

---

The operator must conduct a thorough Pre-Start Inspection of the machine before each work shift – see “Machine Inspections” on page 20.

## General Inspection Checklist

---

Initial	Description
_____	Check that the operator's, safety, and responsibilities manuals are in the storage container located on the platform.
_____	Perform a visual inspection of all machine components. Look for missing parts, torn or loose hoses, hydraulic fluid leaks, torn or disconnected wires, damaged tires etc.
_____	Check all structural components of the machine for cracked welds, corrosion and collision damage.
_____	Check all hoses and the cables for worn or chafed areas.
_____	Check the platform rails and sliding mid-rail entry for damage or modification.
_____	Check that all warning and instructional labels are legible and secure.
_____	Check the tires for damage.
_____	Check the tire pressure (not required for foam filled tires).
_____	Check the lower limit switch for visual damage or loose or missing hardware.
_____	All structural components, pins and fasteners are present and properly tightened.

## Fluid Level Checklist

---

_____	Check for fluid leaks.
_____	Hydraulic fluid level (check with platform fully lowered).

## Secure for operation

---

_____	Secure all covers and panels. Perform Routine Maintenance as needed, then proceed to the Functions Test.
-------	--

DATE \_\_\_\_\_ INSPECTED BY \_\_\_\_\_

## Monthly Inspection Checklist

---



***This checklist must be used at monthly intervals or every 100 hours of machine use, whichever occurs first. Failure to do so could result in death or serious injury.***

---

Scheduled Maintenance Inspections should be conducted by qualified service technicians only. Photocopy this page for reuse. Keep inspections records up to date. Record and report all discrepancies to your supervisor.

**Model Number** \_\_\_\_\_ **Serial Number** \_\_\_\_\_

---

Initial	Description
---------	-------------

---

- |       |  |
|-------|--|
| _____ | Perform all checks listed on Prestart Inspection.  |
| _____ | Inspect the condition of hydraulic fluid in the reservoir. Oil should have a clear amber color.                |
| _____ | Check battery electrolyte level and connections.   |
| _____ | Check wheel lug nuts for proper torque (see <i>Specifications</i> ).   |
| _____ | Check if tires are leaning in or out.  |
| _____ | Inspect all beams and pivot points for signs of wear and/or damage.  |
| _____ | Check the pin joints and retaining rings for security.   |
| _____ | Inspect the entire machine for signs of damage, broken welds, loose bolts, improper or makeshift repairs.      |
| _____ | Check that the platform does not drift down with a full load.  |
| _____ | Lubricate the king pins, steering cylinder pivot points, and tie rod ends (see <i>Lubrication</i> on page 27). |
| _____ | Check all wire connections.  |
| _____ | Check that all adjustable flow valves are locked, check setting if any are not locked.                         |
| _____ | Lubricate the boom gear (see <i>Lubrication</i> on page 27).   |

**DATE** \_\_\_\_\_ **INSPECTED BY** \_\_\_\_\_



## Quarterly Inspection Checklist

---

**WARNING**

***This checklist must be used at quarterly intervals or every 300 hours of machine use, whichever occurs first. Failure to do so could result in death or serious injury.***

---

Scheduled Maintenance Inspections should be conducted by qualified service technicians only. Photocopy this page for reuse. Keep inspections records up to date. Record and report all discrepancies to your supervisor.

**Model Number** \_\_\_\_\_ **Serial Number** \_\_\_\_\_

---

Initial	Description
---------	-------------

---

- |       |   |
|-------|---|
| _____ | Perform all checks listed on Prestart/Monthly Inspection.   |
| _____ | Check the operation speeds to ensure they are within specified limits (see <i>Specifications</i> ).                           |
| _____ | Check the emergency lowering system.  |
| _____ | Clean and lubricate all push button switches with dry lubricant and ensure that the switches operate freely in all positions. |
| _____ | Check the tightness of the platform frame and the linkage pins.   |
| _____ | Check the overall platform and guardrail component stability.   |
| _____ | Check the electrical mounting and hardware connections for security.  |
| _____ | Check the king pins for excessive play.   |

### **Additional maintenance requirements for severe conditions**

---

- |       |  |
|-------|--|
| _____ | Replace hydraulic filter element (under normal conditions replace every six [6] months). |
|-------|--|

**DATE** \_\_\_\_\_ **INSPECTED BY** \_\_\_\_\_

# Annual Inspection Report

**MEC Aerial Platform Sales Corp.**  
 1775 Park Street, Suite 77 • Selma, CA 93662 USA  
 800-387-4575 • 559-891-2488 • Fax: 559-891-2493

Date \_\_\_\_\_  
 Serial Number \_\_\_\_\_  
 Model Number \_\_\_\_\_  
 Date Of Last Inspection \_\_\_\_\_  
 Date Placed In Service \_\_\_\_\_

Customer \_\_\_\_\_  
 Street \_\_\_\_\_  
 City/State/Zip \_\_\_\_\_  
 Phone Number \_\_\_\_\_  
 Contact \_\_\_\_\_

Dealer \_\_\_\_\_  
 Street \_\_\_\_\_  
 City/State/Zip \_\_\_\_\_  
 Phone Number \_\_\_\_\_  
 Contact \_\_\_\_\_

- Check each item listed below.
- Use proper Operator's, Service and Parts manual for specific information and settings.
- If an item is found to be "Unacceptable" make the necessary repairs and check the "Repaired" box.
- When all items are "Acceptable", the unit is ready for service.
- Please fax a copy to MEC at (559) 891-2488 or email to EMAIL ADDRESS

**Key: "Y" Yes/Acceptable**  
**"N" No/Unacceptable**  
**"R" Repaired**  
**"U" Unnecessary/Not Applicable**

Y N R U					Y N R U					Y N R U				
<b>Decals:</b>					<b>Base:</b>					<b>Operation:</b>				
Proper Placement/Quantity					Cover Panels Secure					Wires Tight				
Legibility					Base Fasteners Tight					Switches Secure				
Correct Capacity Noted					Bolts Tight					All Functions Operational				
<b>Rails:</b>					<b>Front Axle/Front Wheel Assemblies:</b>					<b>Emergency Down:</b>				
All Rail Fasteners Secure					Front Axle Mounting (4WD)					Operational				
Entry Gate/Chain Closes Properly					Rear Axle Mounting (4WD)					<b>Slow Speed Limit Switch:</b>				
Manual/Safety Data In Box					Wheel Motors-Mounting Secure					Set Properly				
Rear Rail Pad In Place					Wheel Motors-Leaks					<b>Pothole Bars:</b>				
<b>Extending Platform:</b>					<b>Drive Assembly Front Hubs:</b>					<b>Pressures &amp; Hydraulics:</b>				
Slides Freely					Lug Nuts Torqued Properly					Operate Smoothly				
Latches In Stowed Position					Steering Cylinder Pins Secure					Lock In Place				
Latches In Extended Position					Pivot Points Lubed					Limit Switches Adjusted				
Rail Latches Work Properly					<b>Rear Axle/Rear Wheel Assemblies:</b>					<b>Engine:</b>				
Cable Secure					Castle Nut Torqued Properly					Oil Filter Secure/Chg				
<b>Platform:</b>					Steering Pressure Set					Oil Level Correct/Chg				
Platform Bolts Tight					Brakes Operational					Steering Pressure Set				
Platform Structure					Wheel Motors-Mounting Secure					Drive Pressure Set				
<b>Platform Overload System:</b>					Wheel Motors-Leaks					Lift Pressure Set				
Functional					Lug Nuts Torqued Properly					<b>Options Operational:</b>				
Calibrated					Axle Pivot Libed (4WD)					Hour Meter				
<b>Wire Harnesses:</b>					Axle Lock Operational					Battery Indicator				
Mounted Correctly					<b>Component Area:</b>					Warning Light				
Physical Appearance					Valve Manifold(s) Secure					Warning Horn				
110/220V Outlet Safe/Working					Hoses Tight/No Leaks					Generator				
<b>Elevating Assembly:</b>					D/C Mtr(s) Secure/Operational					Converter				
Beam Structures					Contactors Secure									
Welds					Pump Secure									
Retaining Rings					<b>Batteries:</b>									
Upper Cylinder Pins Secure					Secure									
Lower Cylinder Pins Secure					Fully Charged									
Lower Beam Mounts tight					<b>Battery Charger:</b>									
Rollers Turn Freely					Secure									
<b>Maintenance Locks:</b>					Operational									
Secure					<b>Emergency Stop:</b>									
Operational					Breaks All Circuits									

Comments: \_\_\_\_\_

Signature/Mechanic: \_\_\_\_\_ Date: \_\_\_\_\_  
 Signature/Owner-User: \_\_\_\_\_ Date: \_\_\_\_\_

Art\_3145



# Maintenance

---

**DO NOT** operate this machine until you have read and understood the Safety section of this manual, have performed the Pre-Start Inspection, Routine Maintenance, and Functions Test, have inspected the jobsite for hazards, and have learned the operating procedures for this machine.

Tag and remove a damaged, malfunctioning or modified machine from service. DO NOT use a damaged, malfunctioning or modified machine.

Use the Pre-Start Inspection to determine what Routine Maintenance is required. The operator may perform only the routine maintenance items specified in this manual.

**IMPORTANT**—Scheduled maintenance inspection checklists are included in this manual for use only by qualified service technicians. Only qualified service technicians may perform repairs to the machine. After repairs are completed, the operator must perform a Pre-Start Inspection before proceeding to the Functions Test.



---

***Never perform service on the machine with the platform elevated without first blocking the elevating assembly (see Maintenance Safety on page 26).***

***Never leave hydraulic components or hoses open. They must be protected from contamination (including rain) at all times.***

***Never open a hydraulic system when there are contaminants in the air.***

***Always clean the surrounding area before opening hydraulic systems.***

***Use only recommended lubricants. Improper lubricants or incompatible lubricants may be as harmful as no lubrication.***

***Watch for makeshift “fixes” which can jeopardize safety as well as lead to more costly repair.***

---



---

***Hydraulic fluid under pressure can penetrate and burn skin, damage eyes, and may cause serious injury, blindness, and even death. Correct leaks immediately.***

---



---

***Failure to perform preventive maintenance at recommended intervals may result in the unit being operated with a defect that could result in injury or death of the operator.***

***Immediately report to your supervisor any Defect or malfunction. Any defect shall be repaired prior to continued use of the aerial work platform.***

***Inspection and maintenance should be performed by qualified personnel familiar with the equipment.***

***Fluid leaks under pressure may not always be visible. Check for pin hole leaks with a piece of cardboard, not your hand.***

---

## Routine Maintenance

---

**IMPORTANT**— The operator may perform routine maintenance only. Scheduled maintenance must be performed by qualified service technicians.

**Pre-Start Inspection** Perform routine maintenance as identified in the *Pre-Start Inspection Checklist* on page 21.

## Scheduled Maintenance

---

Maintenance performed monthly, quarterly, annually and bi-annually must be performed by a qualified service technician trained and authorized to perform maintenance on this machine, and must be done in accordance with the procedures outlined in the service manual. Scheduled maintenance inspection checklists are included in this manual for use by qualified service technicians.

Machines that have been out of service for more than three months must receive the quarterly inspection before returning to service.

## Maintenance Safety

---



***Never perform service on the machine with the platform elevated without first supporting the platform/boom assembly.***

---

Use a crane with chains and straps of adequate lifting capacity to support the platform.

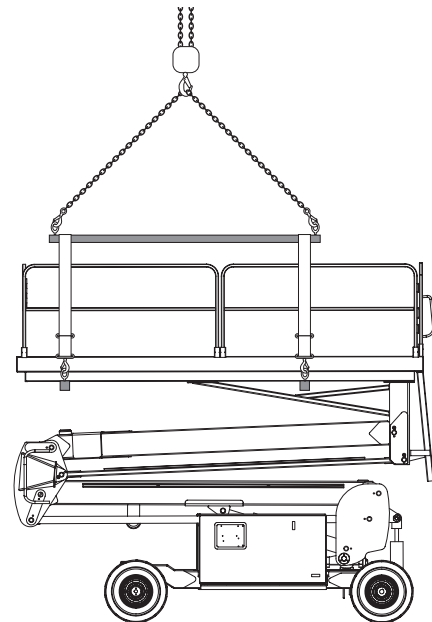

Art\_3098

## Lubrication

Operator may perform routine maintenance only. Lubrication listed as Scheduled Maintenance must be performed by a qualified service technician.

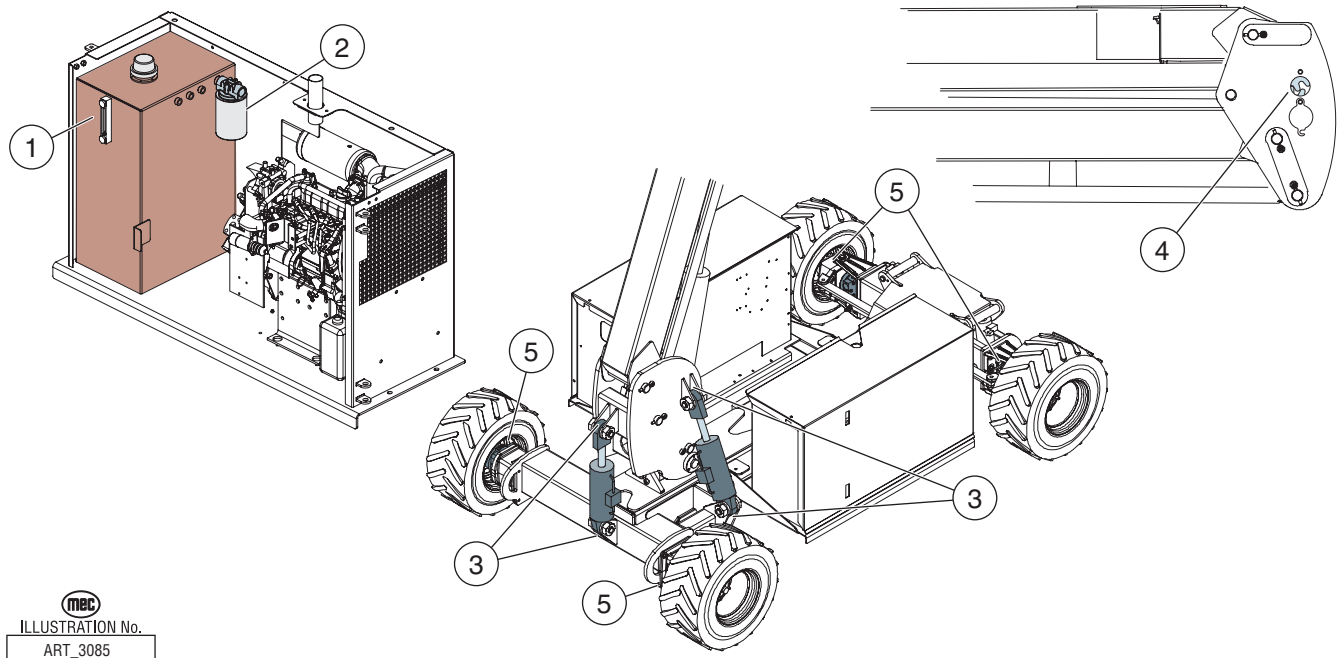

**mec**  
ILLUSTRATION No.  
ART\_3085

### Lubrication

No.	ITEM	SPECIFICATION	FREQUENCY
1	Hydraulic Reservoir	<b>Mobile Fluid DTE 10 Excel ISO 32 or DTE 13 M</b> <i>Do not substitute with lower grade fluids as pump damage may result.</i> Fill to the middle of the sight gauge with platform in the stowed position.	<b>Routine Maintenance</b> Check Daily <b>Scheduled Maintenance</b> Change yearly or every 1000 hours, whichever occurs first
2	Hydraulic Filter	Filter Element	<b>Scheduled Maintenance</b> <b>Normal Conditions</b> Change every six months or 500 hours, whichever occurs first <b>Severe Conditions</b> Change every three months or 300 hours, whichever occurs first
3	Tilt Cylinders Pivot Points	<b>Lithium N.L.G. #2 EP</b> Purge old grease	<b>Scheduled Maintenance</b> <b>Normal Conditions</b> Apply every 6 months or 500 hours, whichever occurs first <b>Severe Conditions</b> Apply every 3 months or 250 hours, whichever occurs first
4	Boom Gear	<b>Mobile NC375 Open Gear Lubricant</b> Apply new grease	<b>Scheduled Maintenance</b> <b>Normal Conditions</b> Apply every 1 months or 100 hours, whichever occurs first <b>Severe Conditions</b> Apply every 2 weeks or 50 hours, whichever occurs first

# Component Locations

## Full Machine

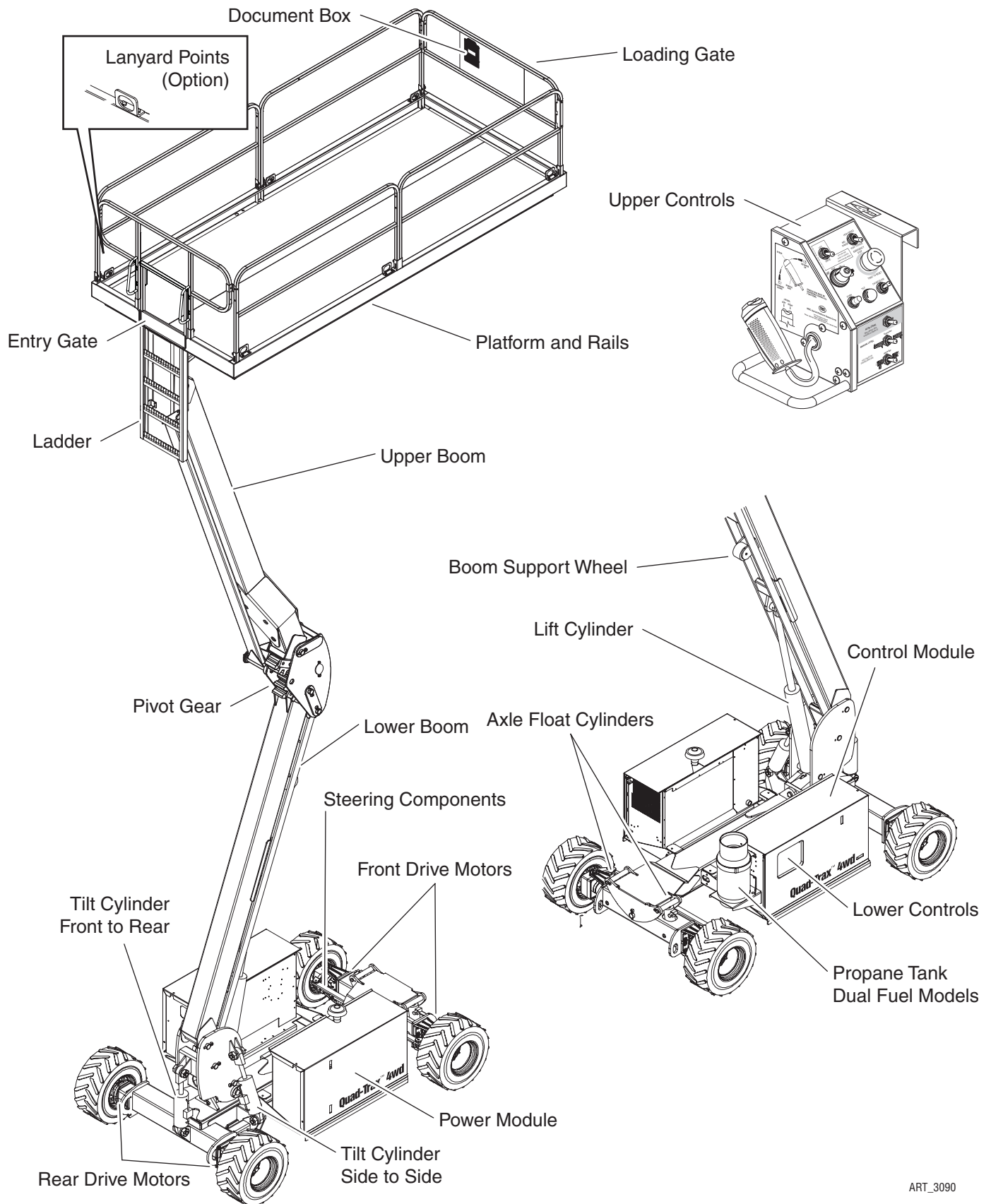

ART\_3090

Modules

Control Module

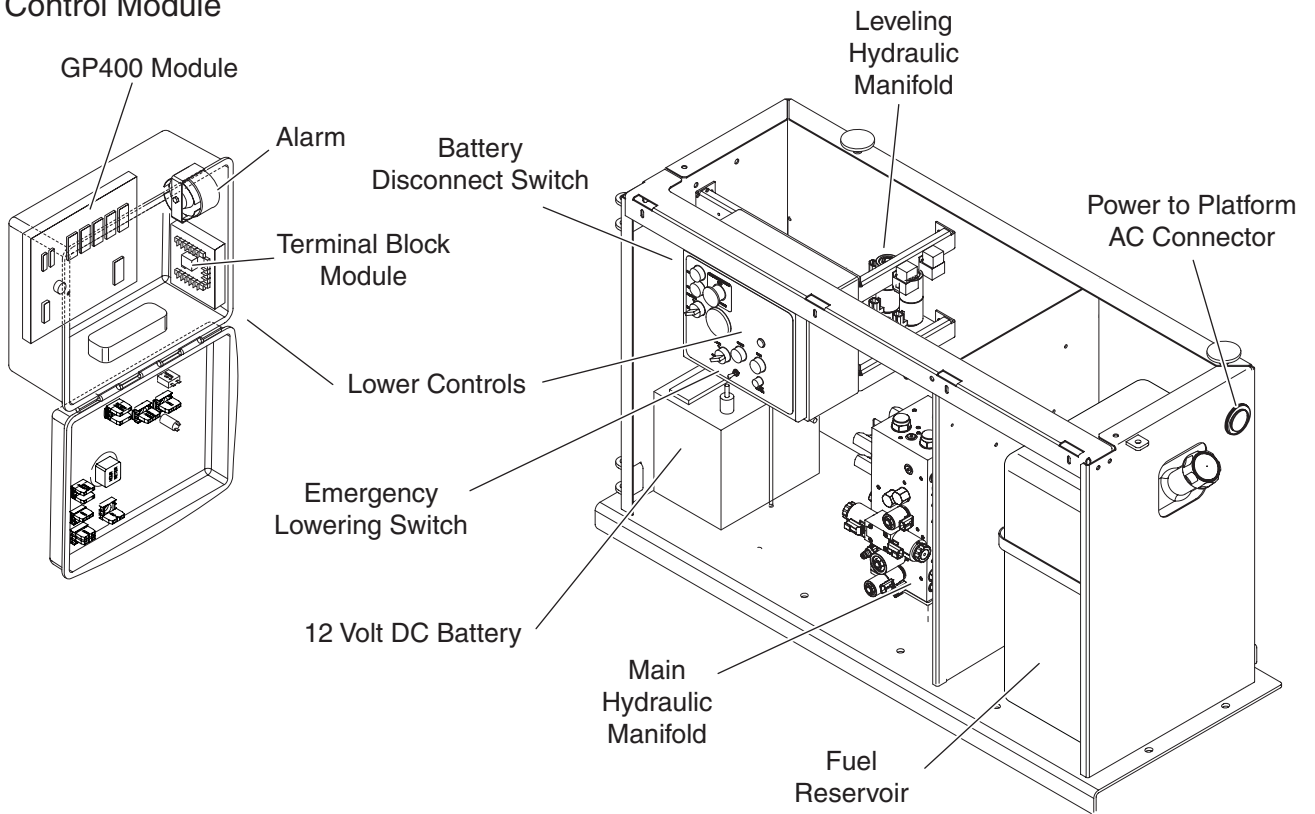

Power Module

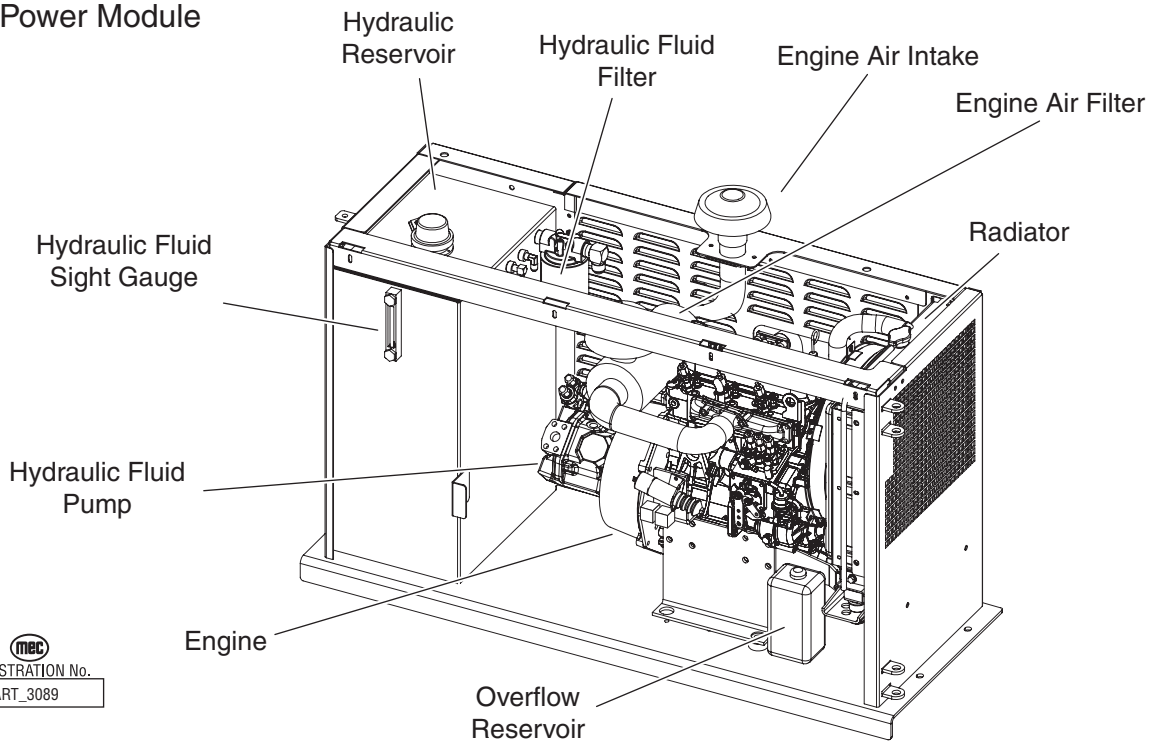
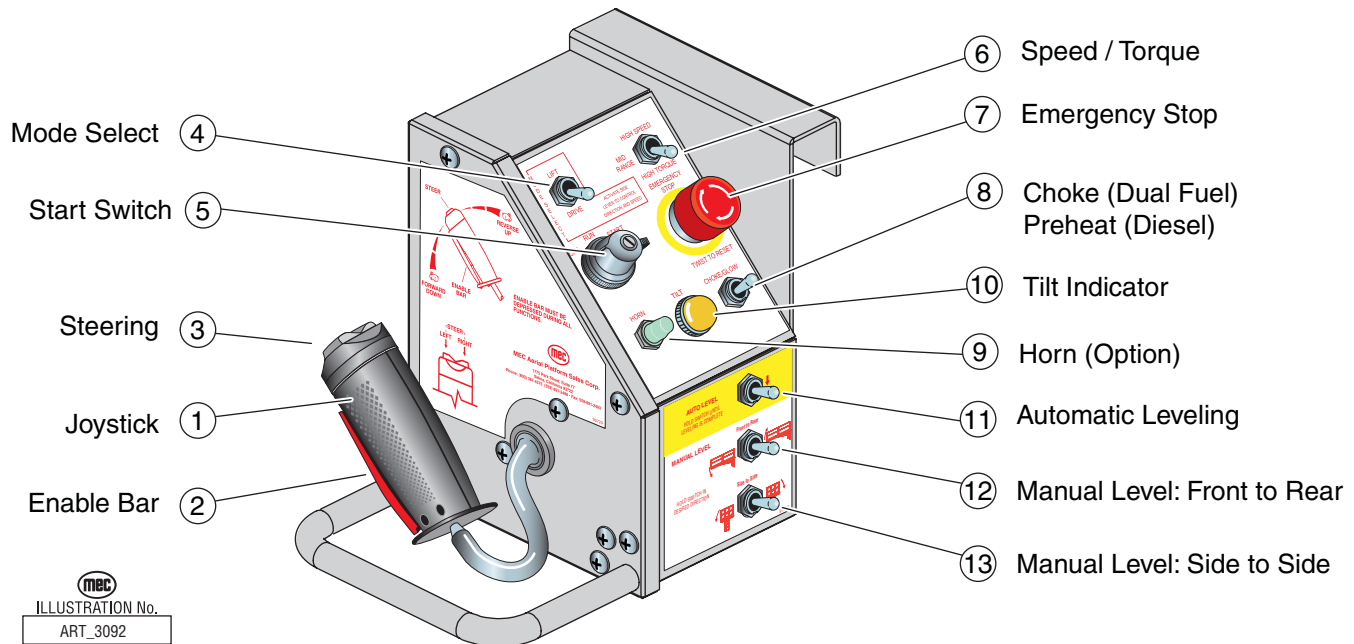

 ILLUSTRATION No. ART\_3089

## Upper Controls



CONTROL		DESCRIPTION	
1	Joystick	DRIVE	Controls Forward and Reverse travel at stepped speeds.
		LIFT	Move toward operator to elevate platform. Lift speed increases proportional to the joystick movement. Will not function if TILT light is ON. Move away from operator to lower platform. Speed is fixed.
2	Enable Bar	Squeeze to enable DRIVE, STEER, and LIFT from joystick.	
3	Steering Switch	Using thumb, press and hold the rocker switch to steer Left or Right.	
4	Mode Selector	Select LIFT or DRIVE function for joystick.	
5	Start Switch	Turn to start engine. Switch will return to RUN position for normal operation. Turn to OFF to shut engine down.	
6	Speed / Torque Switch	HIGH TORQUE	Slow speed. Provides maximum torque for rough terrain.
		MID RANGE	Mid speed. Provides medium torque for smooth to moderate terrain.
		HIGH SPEED	Provides high speed when platform height is below 10 feet (3 m).
7	EMERGENCY STOP Switch	PUSH to stop all machine functions. TURN CLOCKWISE to reset.	
8	Choke/Preheat	Operate when starting in cold start conditions.	
9	Horn (option)	Press to sound warning horn.	
10	Tilt Indicator Light	Light ON indicates platform out of level. Platform will not elevate when TILT light is ON.	
11	Automatic Level Switch	Move switch DOWN and hold until automatic leveling is complete. Tilt Light will turn OFF when platform is level.	
12	Manual Level Switch Front to Rear	Move switch to the left to LOWER the front of the platform. Move the switch to the right to RAISE the front of the platform.	
13	Manual Level Switch Side to Side	Move the switch to the left to move the platform to the LEFT. Move the switch to the right to move the platform to the RIGHT.	



### Lower Controls

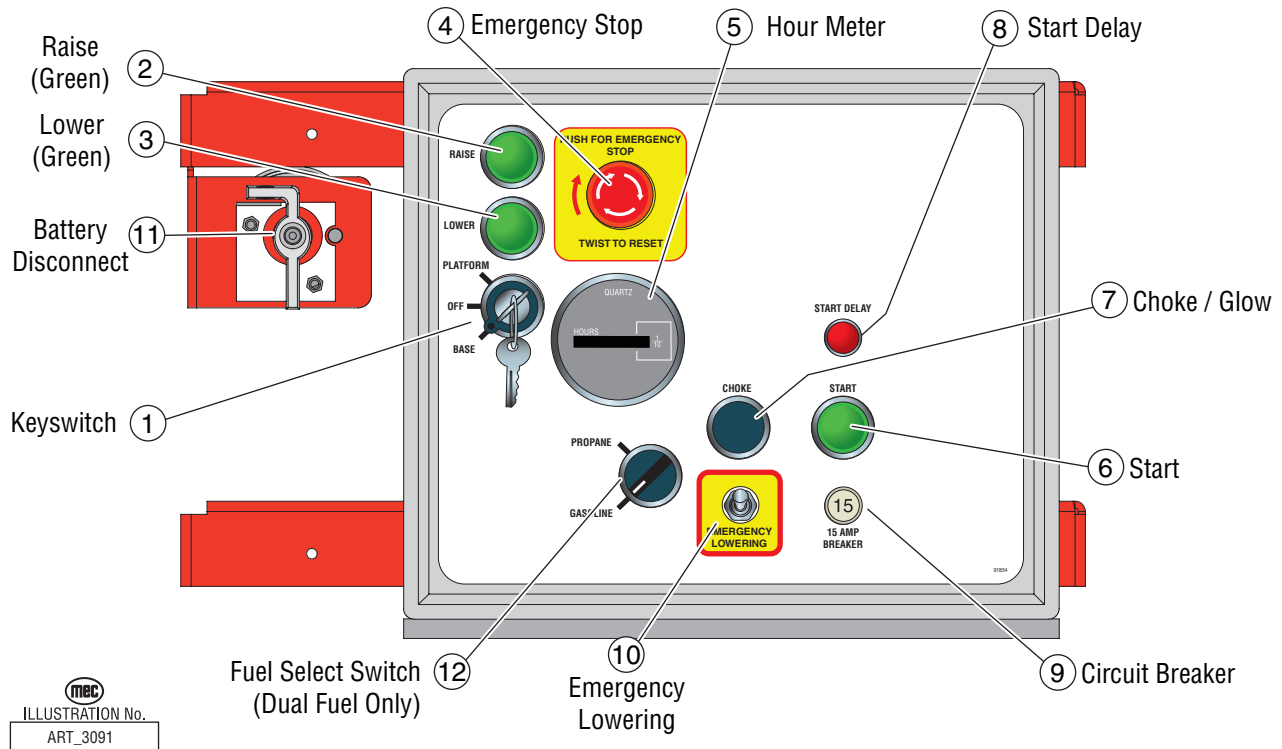

**mec**  
ILLUSTRATION No.  
ART\_3091

CONTROL		DESCRIPTION	
1	Selector Switch	PLATFORM	Select to operate from the platform control panel.
		BASE	Select to operate from the base control panel.
		OFF	Select to stop operation from either control panel.
2	RAISE Button	Press and hold to elevate the platform. Release to stop elevation.	
3	LOWER Button	Press and hold to lower the platform. Release to stop lowering.	
4	EMERGENCY STOP Switch	Press to stop all machine functions. Turn <i>clockwise</i> to reset.	
5	Hour Meter	Indicates total elapsed time of machine operation.	
6	Start Button	Press to start engine. Release when engine starts.	
7	Choke/Glow	Operate when starting in cold start conditions.	
8	Start Delay Light	Prevents over-cranking of engine. When lit, starter is disabled. After approximately 35 seconds the light will go out and starter will operate.	
9	Circuit Breaker	Trips when there is excessive electrical load. Push to reset.	
10	EMERGENCY LOWERING Switch	Push and hold the toggle switch Down to fully lower the platform.	
11	Battery Disconnect	Battery power supply. Turn OFF and padlock to secure machine from unauthorized use.	
12	Fuel Selector (Dual Fuel Only)	Turn switch to select Gasoline or Propane.	

# Decals

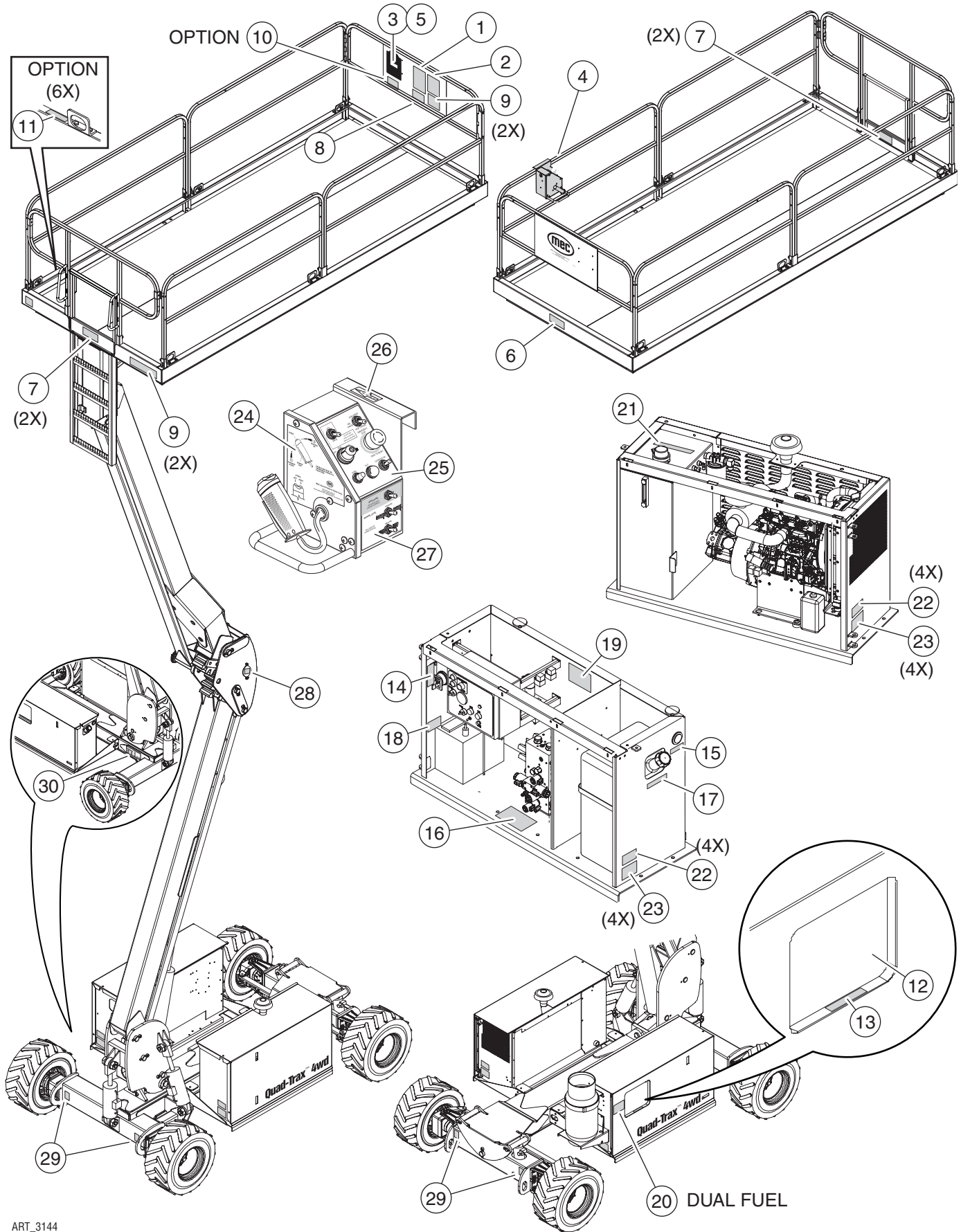

ART\_3144



Decals (continued)

**PLATFORM**

① 91846

**WARNING**

INSPECT MACHINE AND MAKE SURE THAT IT IS OPERATING PROPERLY, THAT ALL NAME PLATE AND SAFETY AND CONTROL DECALS ARE IN PLACE AND LEGIBLE, AND THAT THE MACHINE IS IN ACCORDANCE WITH THE MANUFACTURER'S MAINTENANCE REQUIREMENTS CONTAINED IN THE OPERATION AND MAINTENANCE MANUAL, AND THE DAILY SAFETY CHECKLIST. OPERATE MACHINE WITH EXTREME CAUTION. WATCH FOR OBSTRUCTIONS WHICH MAY STRIKE PLATFORM, PERSONNEL, CONTROLS, OR MACHINE. OPERATE CONTROLS SLOWLY FOR SMOOTH PLATFORM MOTION.

**OTHER HAZARDS**

**FOR DRIVING WITH PLATFORM LOWERED:**

- DO NOT EXCEED MAXIMUM PLATFORM LOAD CAPACITY.
- DO NOT EXCEED MAXIMUM SIDE FORCE AND MAXIMUM NUMBER OF OCCUPANTS.
- DO NOT USE WITHOUT GUARD RAILS IN PLACE, AND ENTRY GATE SECURED.
- DO NOT USE IF WORK PLATFORM IS NOT WORKING PROPERLY OR ANY PART IS DAMAGED OR MISSING.
- DO NOT USE NEAR MOVING VEHICLES OR CRANES.
- DO NOT DRIVE UP OR DOWN A GRADE OF OVER 5% OFF LEVEL.
- DO NOT DRIVE UP OR DOWN A GRADE OF OVER 4%.

**FOR DRIVING WITH PLATFORM ELEVATED:**

- DRIVE ONLY ON A SMOOTH, FIRM, AND PLANAR SURFACE FREE OF OBSTRUCTIONS.
- DO NOT EXCEED MAXIMUM PLATFORM OR EXTENSION LOAD CAPACITY.
- LOAD MUST BE UNIFORMLY DISTRIBUTED.
- IF TILT WARNING LIGHT ILLUMINATES OR TILT ALARM SOUNDS LOWER PLATFORM AND RE LEVEL.
- USE EXTREME CAUTION.

**IMPROPER OPERATION OF THIS MACHINE COULD CAUSE DEATH OR SERIOUS INJURY.**

② 91845

**DANGER**

**YOU MUST NOT OPERATE THIS MACHINE:**

UNLESS YOU HAVE BEEN AUTHORIZED TO USE AND TRAINED IN THE SAFE OPERATION OF THE MACHINE.

TRAINING INCLUDES COMPLETE KNOWLEDGE OF THE SAFETY AND OPERATION INSTRUCTIONS CONTAINED IN THE MANUFACTURER'S MANUAL, AND MANUAL OF RESPONSIBILITIES, YOUR EMPLOYER'S WORK RULES AND APPLICABLE GOVERNMENTAL REGULATIONS.

AN UNAUTHORIZED AND UNTRAINED OPERATOR SUBJECTS YOURSELF AND OTHERS TO DEATH OR SERIOUS INJURY.

**TIP-OVER HAZARDS**

DO NOT DRIVE NEAR DROP-OFFS, HOLES, OPEN ELEVATOR SHAFTS, AND LOADING DOCKS.

DO NOT ELEVATE PLATFORM ON UNDRIVEN OR SOFT SURFACES.

DO NOT DRIVE ONTO UNDRIVEN OR SOFT SURFACES WHEN ELEVATED.

DO NOT RAISE PLATFORM IN WINDY OR GUSTY CONDITIONS.

**ELECTROCUTION HAZARD**

THIS MACHINE IS NOT INSULATED.

MAINTAIN SAFE CLEARANCE FROM ELECTRICAL LINES AND APPARATUS. YOU MUST ALLOW FOR MACHINE SWAY, ROCK OR SAG AND ELECTRICAL LINES SWAYING.

THIS MACHINE DOES NOT PROVIDE PROTECTION FROM CONTACT WITH OR PROXIMITY TO AN ELECTRICALLY CHARGED CONDUCTOR.

YOU MUST MAINTAIN A CLEARANCE OF AT LEAST TEN (10) FEET BETWEEN ANY PART OF THE MACHINE OR ITS LOAD AND ANY ELECTRICAL LINE OR APPARATUS CARRYING UP TO SUBSTANTIAL CURRENTS. ADDITIONAL CLEARANCE IS REQUIRED FOR EVERY ADDITIONAL SUBSTANTIAL VOLTAGE.

**DEATH OR SERIOUS INJURY WILL RESULT FROM CONTACT OR INADEQUATE CLEARANCE.**

③ 90733

**MANUALS INSIDE**

④ 7155

**LOCATE CONTROL BOX HERE**

FOR NORMAL OPERATION OF THIS UNIT

⑤ 90718 **INSIDE DOCUMENT CASE**

**WARNING**

USE OR OPERATION OF AN UNSPECTED WORK PLATFORM COULD CAUSE DEATH, PERSONAL INJURY

DO NOT OPERATE THIS WORK PLATFORM IF AN INSPECTION HAS NOT BEEN PERFORMED WITHIN 12 MONTHS OF THE LAST RECORDED INSPECTION DATE.

STAMP MONTH/DAY/YEAR NEXT TO APPROPRIATE YEAR AFTER EACH INSPECTION.

**NOTICE**

CHANGE OF OWNERSHIP OF THIS WORK PLATFORM MUST BE REPORTED TO MANUFACTURER.

MEC Aerial Platform Sales Corp.  
13141 East Street  
P.O. Box 1000  
Fresno, California 93727 Phone: (509) 283-4628

⑥ 91850

⑧ 91869

**WARNING**

- SHEET LOADING GATE MUST BE IN LOCKED POSITION BEFORE OPERATING FROM PLATFORM.
- PLATFORM ENTRANCE MUST BE PROPERLY CLOSED AND ALL QUADRANTS PROPERLY IN PLACE AND SECURED BEFORE OPERATING FROM PLATFORM.

FAILURE TO FOLLOW INSTRUCTIONS COULD CAUSE DEATH, PERSONAL INJURY AND PROPERTY DAMAGE.

⑨ 91847

**WARNING**

MAXIMUM PLATFORM CAPACITY - EVENLY DISTRIBUTED

1500 LBS  
680 kg

5-PERSONS

**SIDE LOAD**

250 LBS  
1100 N

⑩ 8606

**WARNING**

- LANYARD ANCHORAGE POINTS ARE RECOMMENDED FOR WORK POSITIONING RESTRAINTS ONLY.
- USE OF FALL ARREST SYSTEMS ATTACHED TO ANCHORAGE POINTS ON MOBILE EQUIPMENT MAY CAUSE MACHINE TO TIP, RESULTING IN SERIOUS INJURY OR DEATH.

⑪ 8605 (6 PLACES)

**CERTIFIED LANYARD ANCHORAGE POINT**

**CONTROL MODULE**

⑫ 91854: Dual Fuel 91855: Diesel

⑬ 91848

PLATFORM CAPACITY  
1500 LBS (680kg)

⑭ 9052

⑮ 90751

POWER TO PLATFORM

⑯ 90267

**BRAKE RELEASE**

PUMP

⑰ 9378 (Diesel)

**DIESEL ONLY**

⑱ 8779

**WARNING**

BATTERIES PRODUCE EXPLOSIVE GAS. CHARGE BATTERIES IN WELL VENTILATED AREA. DO NOT EXPOSE TO SPARKS OR FLAMES.

⑳ 6948 (Dual Fuel)

**WARNING**

L.P.G.

- NO SMOKING - WHILE CHARGING TANKS.
- INSURE TANKS PROPERLY USING HOLES IN COLLAR FOR HORIZONTAL MOUNTING AND SLOT FOOTINGS FOR VERTICAL MOUNTING TO INSURE FULL USAGE.
- OPEN VALVE SLOWLY SO THAT HOSE AND TANK PRESSURE CAN EQUALIZE OR VALVE MAY SLUG.
- CLOSE VALVE BEFORE DISCONNECTING AND USE UP FUEL STILL IN LINE.
- FOR PROPER USE OF THE L.P. SYSTEM, THE USE OF FUEL MANUFACTURED TO NATURAL GAS PROCESSORS ASBN SPECIFICATIONS - "H-9" IS RECOMMENDED.

**POWER MODULE**

⑳ 6873

**HYDRAULIC OIL**

㉑ 8502 (4 PLACES)

(not required for Foam Filled tires)

**INFLATE TO TIRE MANUFACTURER'S MAX. SPECIFICATIONS OR SEE SERVICE MANUAL**

㉒ 8519 (4 PLACES)

**WARNING**

- REPLACE TIRES WITH MANUFACTURER'S EQUIPMENT ONLY.
- FAILURE TO USE MANUFACTURER'S TIRES MAY CAUSE MACHINE INSTABILITY.
- REFER TO MAINTENANCE MANUAL FOR REPLACEMENT PART NUMBER.

**CONTROL MODULE AND POWER MODULE FRONT AND REAR**

**UPPER CONTROLS**

㉓ 90729

㉔ 7156

**FRONT**

㉕ 91843

**BOOM**

㉖ 91870

**GREASE PORT**

(Slide to open)

**BASE**

㉗ 11026730

(4 PLACES)

㉘ 91553

MEC AERIAL PLATFORM SALES CORP. 1775 PARK STREET, SUITE 77 SELMA, CA 95660, USA	MFG. DATE XXXXXX	MODEL NUMBER XXXXXX	SERIAL NUMBER XXXXXXXXXX	MODEL YEAR 20XX
MAX. PLATFORM CAPACITY INCLUDING PERSONS XXX kg = X PERSONS + XXX kg EQUIPMENT XXX kg = X PERSONS + XXX kg EQUIPMENT	MAX. DRIVE HEIGHT X X FT X X CM	MACHINE WEIGHT XXXX LBS XXXX kg	MAX. MANUAL FORCE XXX LBS XXX kg	ELECTRICAL VOLTAGE XX VOLTS
MAX. PLATFORM HEIGHT X X FT X X CM	MAX. WIND SPEED X MPH X CM	MAX. GROUND PRESSURE PER WHEEL XXX PSI XXX kPa	MAX. LOAD PER WHEEL XXX LBS XXX kg	MAX. HYDRAULIC SYSTEM PRESSURE XXXX PSI XXXX kPa

THIS MACHINE HAS BEEN CONSTRUCTED IN ACCORDANCE WITH SECTION 4 OF ANSI A92.6-2006. COVERED BY U.S. PAT. #4,916,000 & CANADIAN PAT. #42,116,070.

# Troubleshooting



**WARNING**

**Should you experience erratic operation or notice any malfunction while operating this machine, discontinue use immediately.**

**Call for assistance and report the incident to your supervisor, and do not use the machine until it has been checked by a trained, qualified mechanic.**

## Machine functions will not operate

### Lower Controls

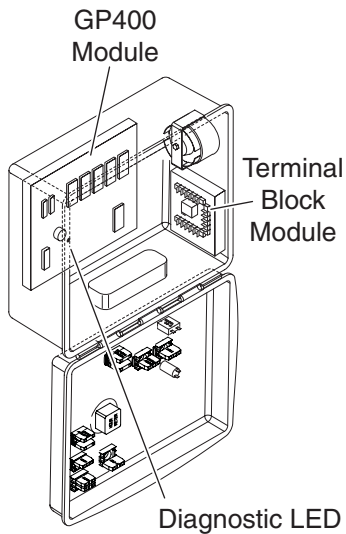

- Battery Disconnect Switch ON?
- Battery fully charged?
- Function toggle switch or the enable switch not activated?
- Selector key switch in proper position?
- Both EMERGENCY STOP switches reset?
- Hydraulic fluid level low?
- Obvious fluid leak or damaged component?
- Wires disconnected, broken, or loose?
- Motor control processor Diagnostic LED OFF?  
*LED should be ON. If LED is OFF or FLASHING, refer to Service Manual or contact MEC Technical Support.*

ART\_3093

# Serial Plate Location

The serial plate is attached to the machine at the time of manufacture. Important information about the machine is recorded on the serial plate.

## Serial Plate Description

<b>MEC</b> MEC AERIAL PLATFORM SALES CORP. 1775 PARK STREET, SUITE 77 SELMA, CA 95962, USA		<b>MFG. DATE</b> XXXX	<b>MODEL NUMBER</b> XXXXXX	<b>SERIAL NUMBER</b> XXXXXXXXX	<b>MODEL YEAR</b> 20XX
<b>MAX. PLATFORM CAPACITY INCLUDING PERSONS</b> XXX kg = X PERSONS + XXX kg EQUIPMENT XXX kg = X PERSONS + XXX kg EQUIPMENT		<b>ELECTRICAL VOLTAGE</b> XX VOLTS		<b>MAX. MANUAL FORCE</b> XXX LBS XXX N	
<b>MAX. DRIVE HEIGHT</b> X X FT X.X m	<b>MACHINE WEIGHT</b> XXXX LBS XXXX kg	<b>MAX. GROUND PRESSURE PER WHEEL</b> XX PSI XX kg/cm <sup>2</sup>		<b>MAX. LOAD PER WHEEL</b> XXX LBS XXX kg	<b>MAX. HYDRAULIC SYSTEM PRESSURE</b> XXXX PSI XXXX bar
<b>MAX. PLATFORM HEIGHT</b> XX FT X.X m	<b>MAX. WIND SPEED</b> X MPH X m/s	<small>THIS MACHINE HAS BEEN CONSTRUCTED IN ACCORDANCE WITH SECTION 4 OF ANSI A92.2008 COVERED BY US PAT. #5,476,050 &amp; CANADIAN PAT. #2,115,870 9192</small>			

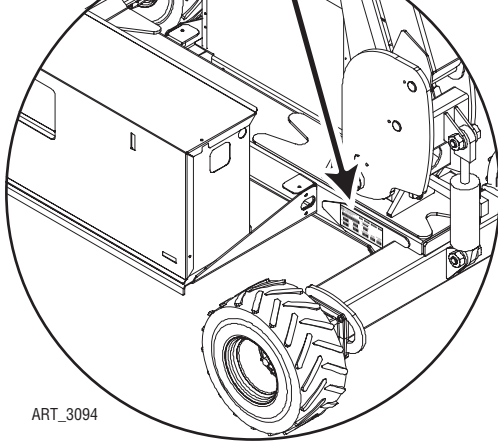

ART\_3094

## Serial Plate Item Information Defined

### MFG DATE

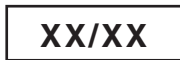

ART\_2377

### MODEL NUMBER

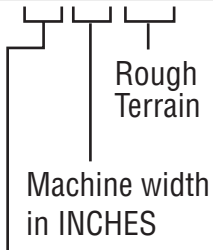
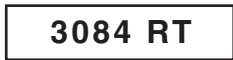

Max. platform height in FEET

ART\_3087

**MFG DATE.** Month / Year of manufacture

**MODEL NUMBER.** Identifies the machine.

**SERIAL NUMBER.** Identifies a machine with reference to its original owner. Refer to the number when requesting information or ordering parts.

**MAX. WIND SPEED.** The maximum safe wind speed at which the machine can be elevated.

**MAX. PLATFORM CAPACITY INCLUDING PERSONS.** The maximum safe load (persons + equipment) which can be evenly distributed on the platform at any elevation

**MAX. ALLOWABLE MANUAL FORCE.** The maximum safe force that the occupant can exert laterally on an object outside the platform.

**MAX. PLATFORM HEIGHT.** The maximum attainable height measured from level ground surface to platform floor.

**MAX. DRIVE HEIGHT.** The maximum safe platform height at which the machine can be driven.

**MAX. LOAD PER WHEEL.** The maximum safe weight applied to each wheel. Calculated with all available options installed.

$$Fw = 30\% (Wm + Wc + Wopt)$$

**MAX. GROUND PRESSURE PER WHEEL.** The amount of pressure exerted on the surface at each wheel. Calculated with all available options installed.

$$Pmax = 30\% (Wm + Wc + Wopt) / \text{Contact Area}$$

**STANDARD MACHINE WEIGHT.** The weight of the machine with no options.

**OPTIONAL EQUIPMENT ADDS TO STANDARD MACHINE WEIGHT.** The weight of installed optional equipment.

# Transport and Lifting Instructions.

## Safety Information

### WARNING

*This section is provided for reference and does not supersede any government or company policy regarding the loading, transport or lifting of MEC machinery.*

*Drivers are responsible for loading and securing machines, and should be properly trained and authorized to operate MEC machinery. Drivers are also responsible for selecting the correct and appropriate trailer according to government regulations and company policy. Drivers must ensure that the vehicle and chains are strong enough to hold the weight of the machine (see the serial number plate for machine weight).*

## Loading

### Free-wheel configuration for Winching or Towing.

### CAUTION

*Prior to manually releasing brakes, be sure the wheels are chocked to prevent machine from moving.*

### DANGER

**RUNAWAY HAZARD!**

*After releasing the brakes there is nothing to stop machine travel. Machine will roll freely on slopes.*

The machine can be winched or towed short distances at speeds not to exceed 5 MPH (8.05 kph). Before towing or winching the machine, it is necessary to release the brakes. Reset the brakes after towing or winching.

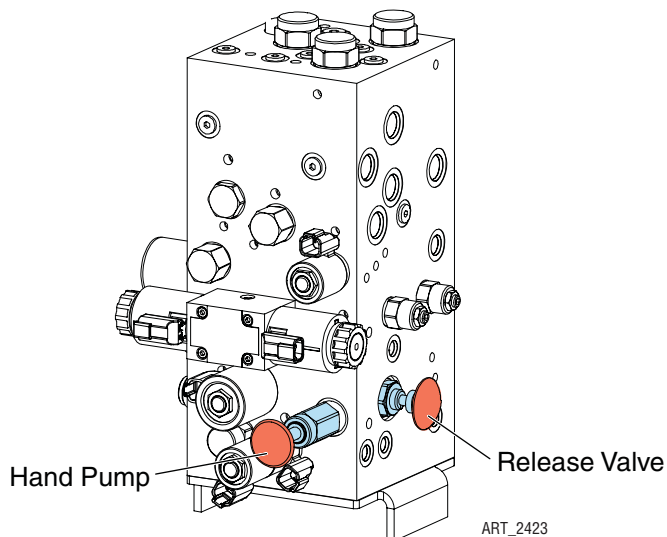

### Disengage Brakes before Towing or Winching

- Chock the wheels.
- Push and hold the release valve.
- Using the hand pump on the manifold, pump valve until pressure is built and valve cannot be pumped.
- Machine is now ready for towing.

### Engage Brakes before Driving

- Pull out the manual brake release valve to reset brakes.

**Note:** Brakes will reset automatically when drive function is activated.

## Driving or Winching onto or off of a Transport Vehicle

**WARNING**

**MEC does not recommend unassisted loading or unloading.**

**Always attach the machine to a winch when loading or unloading from a truck or trailer by driving. Read and understand all safety, control, and operating information found on the machine and in this manual before operating the machine.**

- Attach the machine to a winch.
- Remove all machine tie downs. Remove wheel chocks.

### Driving

- Turn the base key switch to PLATFORM. Check that the EMERGENCY STOP switch is reset by turning it clockwise.
- Enter the platform and reset the Platform EMERGENCY STOP switch.
- Test platform control functions.
- Carefully drive the machine off the transport vehicle with the winch attached.

**Note:** The brakes are automatically released for driving and will automatically apply when the machine stops.

### Winching

- Disengage brakes (see *Disengage Brakes before Towing or Winching* on page 36).
- Carefully operate the winch to lower the machine down the ramp.
- Chock the wheels and engage the brakes.

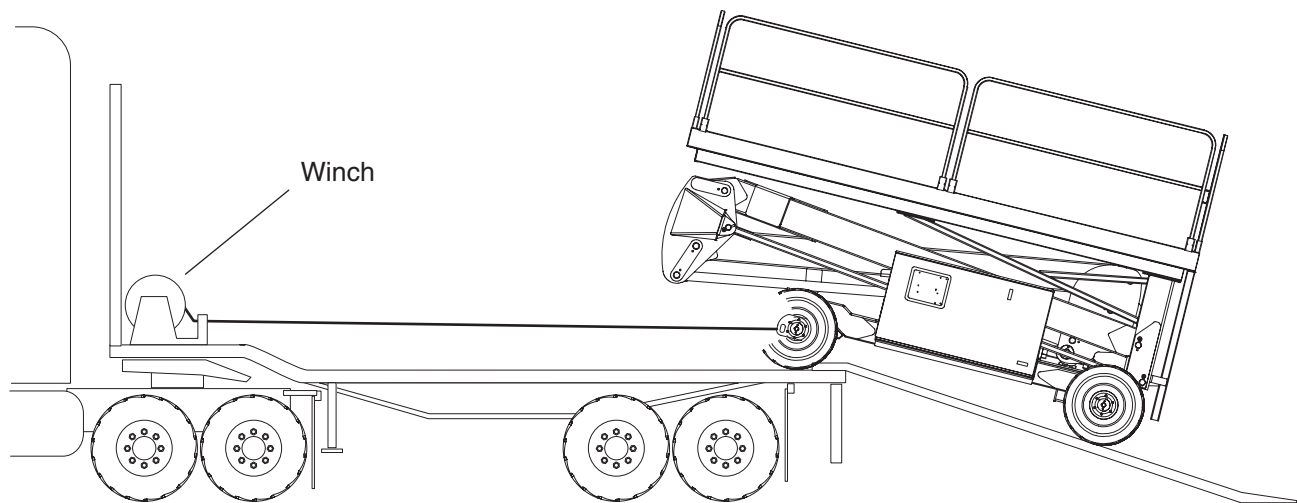

ART\_3086

## Lifting and Tie Down Instructions

**WARNING**

**Only qualified riggers should rig and lift the machine.**

**Ensure that the crane capacity, loading surfaces and straps are sufficient to withstand the machine weight. See the serial plate for the machine weight.**

- Fully lower the platform. Be sure the extension deck is retracted and the module doors are closed and secure. Remove all loose items from the machine.
- Determine the center of gravity of the machine.
- Attach rigging to the designated lift points *only*.
- Adjust the rigging to prevent damage to the machine and to keep the machine level.

### Securing to Truck or Trailer for Transport

- Lock the extension deck in the retracted position.
- Turn the key switch to OFF and remove the key before transport.
- Turn the battery disconnect switch to OFF before transport.
- Inspect the entire machine for loose or unsecured items.
- Use chains or straps of ample load capacity.
- Use a minimum of two (2) chains or straps.
- Adjust the rigging to prevent damage to the chains and the machine.

### Center of Gravity and Lifting Points

Center of Gravity	X Axis	Y Axis
3084	45.89 in. / 116.57cm	10.89 in. / 27.65 cm

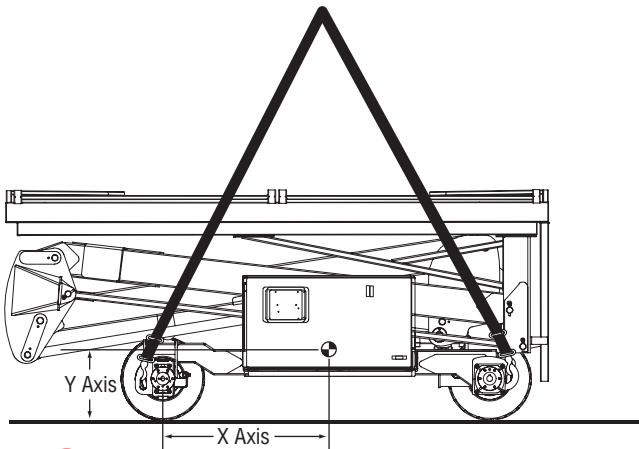

**mec**  
ILLUSTRATION No.  
ART\_3104

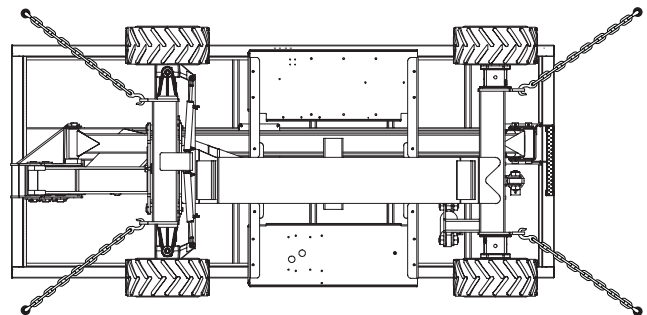
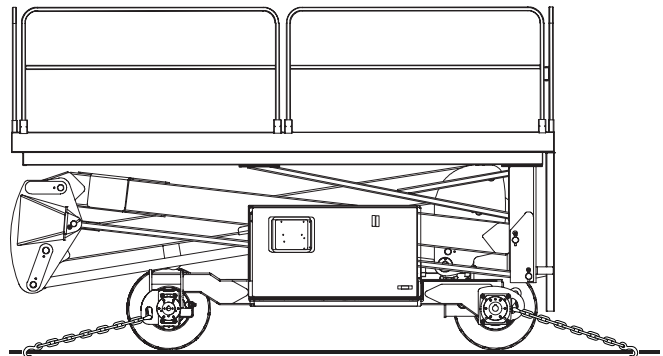









## **Limited Owner Warranty**

---

MEC Aerial Platform Sales Corp. warrants its equipment to the original purchaser against defects in material and/or workmanship under normal use and service for one (1) year from date of registered sale or date the unit left the factory if not registered. MEC Aerial Platform Sales Corp. further warrants the structural weldments of the main frame and scissor arms to be free from defects in material or workmanship for five (5) years from date of registered sale or date unit left the factory if not registered. Excluded from such warranty is the battery(s) which carries a ninety (90) day warranty from described purchase date. Warranty claims within such warranty period shall be limited to repair or replacement, MEC Aerial Platform Sales Corp's option, of the defective part in question and labor to perform the necessary repair or replacement based on MEC Aerial Platform Sales Corp's then current flat rate, provided the defective part in question is shipped prepaid to MEC Aerial Platform Sales Corp. and is found upon inspection by MEC Aerial Platform Sales Corp. to be defective in material and/or workmanship. MEC Aerial Platform Sales Corp. shall not be liable for any consequential, incidental or contingent damages whatsoever. Use of other than factory authorized parts; misuse, improper maintenance, or modification of the equipment voids this warranty. The foregoing warranty is exclusive and in lieu of all other warranties, express or implied. All such other warranties, including implied warranties of merchantability and of fitness for a particular purpose, are hereby excluded. No Dealer, Sales Representative, or other person purporting to act on behalf of MEC Aerial Platform Sales Corp. is authorized to alter the terms of this warranty, or in any manner assume on behalf of MEC Aerial Platform Sales Corp. any liability or obligation which exceeds MEC Aerial Platform Sales Corp's obligations under this warranty.



**MEC Aerial Platform Sales Corp.**

1775 Park Street, Suite 77 • Selma, CA 93662 USA  
Ph: 1-800-387-4575 • 559-891-2488 • Fax: 559-891-2448  
[www.mecAWP.com](http://www.mecAWP.com)