



BRUSH BANDIT

**BUILT WITH QUALITY
AND DESIGN FIRST**

ATTENTION:

Depending on what replacement parts you are ordering, we will need the following information:

GRINDER COMPONENTS

Serial Number
Model Number of Grinder

ENGINE COMPONENTS

Brand
Engine Serial Number
Engine Model Number



STUMP GRINDER MODELS 2550/2550T OPERATING & PARTS MANUAL

Model No: _____

Serial No: _____

DEALER:

Name: _____

Address: _____

City/State: _____

Phone No: _____

Delivery Date: _____

Engine Make: _____

Serial No: _____

Clutch Make: _____

Model: _____ S/N _____

Copyright 10/14

MANUFACTURED BY
BANDIT INDUSTRIES, INC.

6750 Millbrook Road
REMUS, MICHIGAN, USA 49340

PHONE: (800) 952-0178 IN USA
PHONE: (989) 561-2270 OR 561-2272
FAX: (989) 561-2273 ~ SALES DEPT.
FAX: (989) 561-2962 ~ PARTS/SERVICE
E-MAIL: www.banditchippers.com

IT IS VERY IMPORTANT THAT THIS FORM IS FILLED OUT COMPLETELY & ACCURATELY. IF WE CANNOT READ THE PURCHASER'S INFORMATION OR IT IS INCORRECT, OUR CUSTOMER LIST WILL NOT BE ACCURATE.

IMPORTANT - THIS FORM MUST BE RETURNED TO THE CUSTOMER DATA DEPARTMENT WITHIN TEN (10) DAYS IN ORDER TO VALIDATE WARRANTY

Customer Data Department
6750 Millbrook Road
Remus, MI, USA 49340
Phone: (800) 952-0178 in USA
Phone: (989) 561-2270
Fax: (989) 561-2273
E-mail: www.banditchippers.com

WARRANTY VALIDATION FORM
(STUMP GRINDER)

PURCHASER / OWNER INFORMATION:

Company Name _____ Contact Name _____
Mailing/Street Address _____ City _____
State _____ Zip Code _____ Phone Number (____) _____
E-mail _____ Machine Model No. _____ Serial No. _____
Date Put Into Service _____ Machine Hours _____ Engine Make _____
Engine Serial No. _____

DEALER / SELLER INFORMATION:

Dealer/Seller Name _____ Contact Name _____
Mailing/Street Address _____ City _____
State _____ Zip Code _____ Phone Number (____) _____

- 1. Customer has been instructed and understands operation and all safety aspects of operating the equipment.
2. Customer has been instructed and understands that everyone within 100 feet (30 m) of machine must wear personal safety equipment (i.e. hard hat, face shield, safety glasses, gloves, ear protection, etc.)
3. Customer has been instructed and understands equipment maintenance schedules, procedures, and that it is their responsibility to perform maintenance (i.e. retightening all fasteners as needed, clutch and belt adjustments, etc.)
4. Customer has been advised and understands not to reach near the cutter head with hands or feet or to be located near the debris field with engine running. The machine operators must always be located within easy reach of all control and shut down devices.
5. Customer understands to not start grinding a stump without checking for power lines, water lines, sewer lines, phone lines, etc.
6. Customer understands the purpose of and how to operate the shut down/shut off devices, and will not attempt to override any safety devices or guards.
7. Customer has been instructed and understands to always remove the ignition key and completely disconnect battery from cables, wait for the cutter head to come to a complete stop, and to install the cutter head lock before performing any type of maintenance on the machine. Allow all the time necessary for the cutter head to come to a complete stop before opening the cutter head guard or starting any maintenance or service procedures. Customer has been shown and understands the purpose of the beltshield inspection hole and to not attempt any maintenance until belts are visually confirmed to have come to a complete stop.
8. Customer has been instructed and understands: To Not operate this machine without the factory approved cutter head guard assembly in place. To Not operate this machine with any type of make shift cutter head guard. To Not operate this machine under any circumstances with the cutter guard open or unsecured.
9. Customer has reviewed and understands limited warranty, and all written and visual instructions.
10. Customer has received, been advised, and understands the manuals, and the Safety/Service video supplied with the grinder.
11. All Danger, Warning and Operational decals are properly displayed on equipment and fully understood by customer.
12. Customer has been instructed, understands, and agrees that all potential operators must: See the supplied video, be instructed on all Danger, Warning, and Operational decals, read the manual and follow the procedures.

I have inspected this equipment and find it in correct working condition. To the best of my knowledge, the customer and his/her personnel are aware of, and agree to the above procedures.

Signed: _____ Date: _____
(Dealer Representative)

The equipment has been thoroughly checked by the above named dealer representative, and I am satisfied with his/her instructions. I have also read, understand, and agree to reverse side of page.

Signed: _____ Date: _____
(Customer)

OPERATING INSTRUCTIONS BRUSH BANDIT STUMP GRINDERS

SAFETY ALERT SYMBOLS AND NOTATIONS

Signal Word	Likelihood of Occurrence	Degree of Potential Injury or Damage
⚠ DANGER	Will occur if warning is ignored	Severe
⚠ WARNING	Can occur if warning is ignored	Severe
⚠ CAUTION	Will or can occur if warning is ignored	Minor to Severe
NOTICE	Important, but not hazard related	Minor

THIS IS GENERAL INFORMATION REVIEW, UNDERSTAND AND FOLLOW DETAILED INFORMATION IN MANUALS AND DECALS AT ALL TIMES

⚠ DANGER

This machine is equipped with safety decals, guards and designs for your protection.

Don't ever take the machine for granted, always be cautious and careful when operating your equipment.

Read and follow all the instructions in your manual thoroughly. Your safety is dependent on your knowledge of how to operate and maintain this machine. You may obtain additional copies of this manual from your Bandit Dealer.

Before operating machine, you must have all potential operators; read and understand manuals and decals, watch the video and follow the recommendations.

Regardless of how hard a manufacturer tries to produce a safe machine, accidents still happen. Normally accidents are caused by people making mistakes. They do not read the manual, they ignore warning decals or do not use lockouts provided for their safety. This normally happens after the person has become accustomed to the machinery. In the initial start up and operation of the machinery, they are cautious, they are very careful because they do not understand the machine.

This equipment is intended for use by personnel who are experienced with similar equipment. Always operate safely. There should be at least two qualified and trained operators at the work site. They should be positioned in safe working locations, following safety procedures and instructions, and aware of each others whereabouts. There should, also, be at least two people on site during maintenance and service procedures in case an accident should occur. Never operate any machine while under the influence of drugs or alcohol.

Keep children, bystanders and animals clear of working area. Never operate equipment that is in need of repair or adjustment.

⚠ DANGER

Torn or loose clothing is more likely to get caught in moving machinery parts or tree branches. Keep such items as long hair, shirt sleeves, and shirt tails properly contained. Avoid wearing necklaces, rings, watches, and especially neckties while operating this machinery. Make sure the machine is in excellent condition, and all the guards are in place, tight and secure.

Wear all personal protection equipment and follow all safety standards per ANSI and OSHA instructions. Examples of equipment: hard hat, face shield, safety glasses, gloves, ear protection, etc. Do not wear gauntlet or secured fit gloves. Always keep a fully charged fire extinguisher with the machine while operating or servicing the machine.

⚠ DANGER

Never go near cutter wheel or teeth while engine is running or cutter wheel is coasting to a stop.

⚠ DANGER

Before starting the machine, take a minute to check a few things. The grinder should be in an area restricted from people passing by. This area around the grinder must be free of all objects that can obstruct your movement when working with the grinder. The machine should be checked for loose tools or foreign objects, especially in the grinding area. All tools not in use should be secured in a tool box.

⚠ DANGER

Do Not start to grind a stump unless you are completely sure there are not any power lines, water lines, sewer lines, phone lines, etc. in the area above or below the ground level where you are grinding.

⚠ DANGER

Do not go near or in-line with the debris field of the stump grinder while in operation. While grinding stumps, the chips and portions of the stump fly from the cutter wheel and can cause severe injury.

⚠ WARNING

Operators **must** at all times be located within easy reach of all feed control and shut-off devices when the unit is running. They must be attentive and prepared to activate the devices.

⚠ DANGER

Never grind materials that might contain wires, stones, nails, or other metal objects which may damage the teeth and become dangerous projectiles. Remove all rocks and stones from stump grinding area.

⚠ DANGER

Before attempting any type of maintenance disengage clutch, turn off engine, wait for the cutter wheel to come to a complete stop, install the cutter wheel lock pin, disconnect battery, and make sure the ignition key is in your possession.

ALWAYS install the lock pin into the cutter lock tube before working on the grinder.

Simply slide the lock pin into the cutter wheel lock tube. This is to ensure that the cutter wheel cannot be started while you are working on the grinder. If for some reason the cutter wheel would start to turn, it would simply hit the lock pin.

⚠ WARNING

It is very important after you have operated a new machine for approximately an hour to shut down the machine and recheck all nuts and bolts. It is normal for nuts and bolts to loosen once on a new piece of machinery. If you tighten them now, there is a good possibility they won't loosen again. Certain nuts and bolts should be checked periodically such as cutter teeth bolts, etc. for torque and fit.

Most of the nuts used on the Bandit Grinder are self locking. After a nut or bolt has been removed five times, it should be replaced to ensure proper tightness. This is especially critical on the cutter tooth bolts!

After the engine is started, let the grinder wheel turn at the lowest RPM's possible. Listen for any type of noise that is foreign. Any steel on steel noise is foreign. If you hear a noise, stop the engine, find the problem and fix it.

START-UP PROCEDURES

Position the engage handle in the disengaged position and start the engine. Let the engine warm up at 1000 RPM's. (Follow engine manual information.) The machine may show signs of vibration until the engine can set at full throttle. The engine causes most of this vibration until it is brought up to full throttle. Engage cutter wheel.

Once the engine is properly warmed up, bring the engine to full throttle. (Follow engine break-in procedures.)

Make sure to wear all personal protection equipment and follow all safety standards per ANSI and OSHA instructions. Examples of equipment: hard hat, face shield, safety glasses, gloves, ear protection, etc.

**TO BE RETURNED AFTER THIRTY (30)
DAYS OF OPERATION**

DATE PURCHASE: _____

MODEL: _____

SERIAL NUMBER: _____

DEALER NAME: _____

Please return to: Customer Data Department
6750 Millbrook Road
Remus, MI 49340

Phone: (800) 952-0178 in USA

Phone: (989) 561-2270

Fax: (989) 561-2273

E-mail: www.banditchippers.com

STUMP GRINDER QUALITY REPORT

All of the employees that build your equipment strive to manufacturer the **very best quality** product on the market. We would appreciate your efforts in letting us know how we are doing.

We would like you to operate your machine for thirty (30) days and then fill out this questionnaire and mail it to us. This will help us to keep producing a good product and improving our products through your recommendations.

1. Did your machine perform to your expectations? _____
2. Was the machine delivered on schedule? _____
3. Was the paint color and finish to your satisfaction? _____
4. Was machine equipment as ordered? _____
5. Did all welds appear to be high quality? _____
6. Was the overall machine to your liking? _____
7. What problems have you experienced? _____
8. Have any components regularly loosened that caused problems? _____
9. Does the hydraulic system seem to have adequate power? _____
10. Is the machine manufactured to accommodate service in an adequate manner? If not, please explain:

11. General comments and/or suggestions: _____

12. Would you like to be contacted concerning more of our equipment? _____

YOUR COMPANY: _____

NAME: _____

ADDRESS: _____

CITY: _____

STATE & ZIP: _____

PHONE: (____) _____

E-MAIL: _____

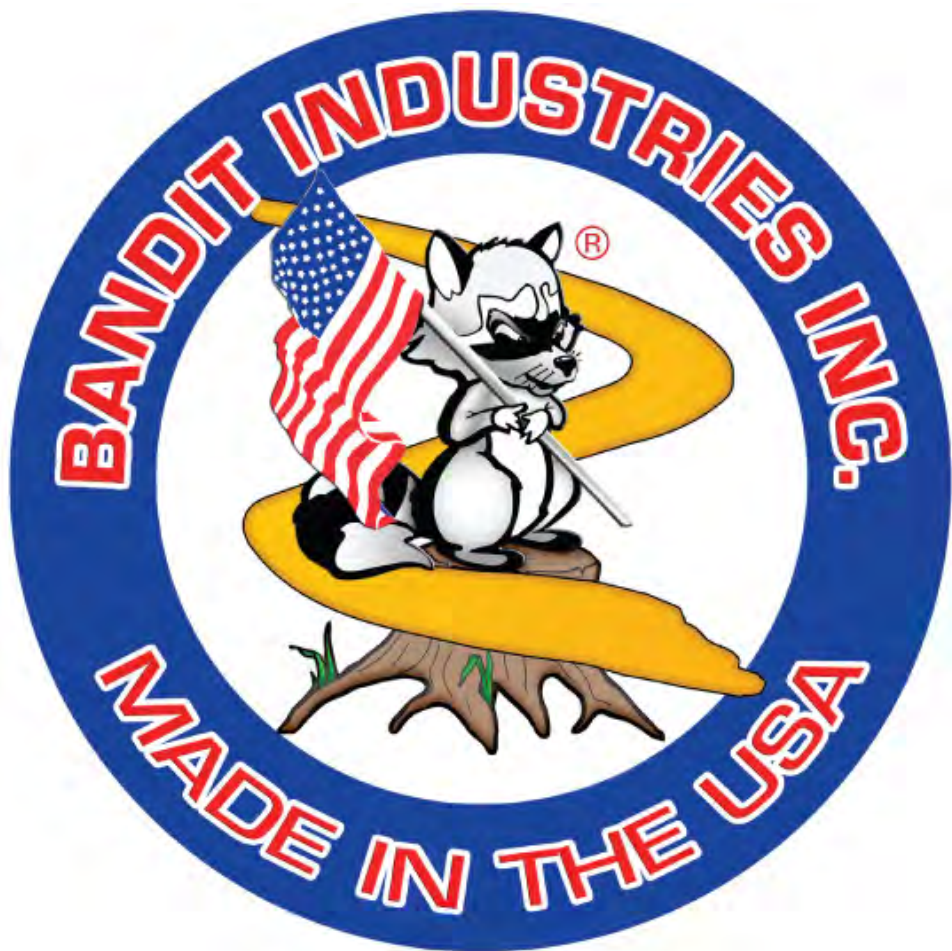

TABLE OF CONTENTS

	PAGE
INTRODUCTION & WARRANTY	2
SERIAL NUMBER LOCATION	6
SAFETY PROCEDURES	7
EQUIPMENT SPECIFICATIONS	11
DECALS	12
CONTROLS.....	15
MACHINE OPERATION	25
TRANSPORTATION PROCEDURES	28
MAINTENANCE	30
HYDRAULIC SECTION	41
CUTTER WHEEL SECTION	53
ELECTRICAL SECTION	56
LUBRICATION & COOLANT.....	68
REPLACEMENT PARTS SECTION	69
FRAME COMPONENTS	70
STEERING COMPONENTS	74
CUTTER WHEEL ARM COMPONENTS	76
CUTTER WHEEL COMPONENTS	78
TANK COMPONENTS	80
CONTROL BOX COMPONENTS	81
SWING OUT COMPONENTS	82
REMOTE CONTROL COMPONENTS	83
GRADING BLADE COMPONENTS	84
HYDRAULIC COMPONENTS	85
SERVICE RECORD	94

NOTICE

ANY PART, PORTION, DESIGN, NUMBER, SPECIFICATION, AND/OR DIMENSION IN THIS MANUAL IS SUBJECT TO CHANGE WITHOUT NOTICE BY THE MANUFACTURER.

INTRODUCTION

The purpose of this manual is to provide the user with specifications and procedures for the operation, maintenance and repair of this BANDIT product. As with any piece of equipment, safety should always be a constant thought while the machine is being operated, serviced or stored. In order to highlight this consideration, the material which addresses safety is preceded by the following signal words:

Signal Word	Likelihood of Occurrence	Degree of Potential Injury or Damage
⚠ DANGER	Will occur if warning is ignored	Severe
⚠ WARNING	Can occur if warning is ignored	Severe
⚠ CAUTION	Will or can occur if warning is ignored	Minor to Severe
NOTICE	Important, but not hazard related	Minor

The equipment is designed and manufactured in accordance with the latest product industry standards. This alone does not prevent injury. It is the operator's responsibility to use good judgement and follow the warnings and instructions as indicated in this manual, on the machine and follow all safety standards per ANSI and OSHA instructions.

⚠ WARNING

Improper use of the product can result in severe personal injury. Personnel using the equipment must be qualified, trained and familiar with the operating procedures as defined in this manual, prior to operating the product.

⚠ WARNING

It is the responsibility of the owner or employer to ensure that the operator is trained and practices safe operation while using and servicing the machine. It is also the owner's responsibility to provide and follow a regularly scheduled preventative maintenance and repair program on the product, using only factory approved replacement parts. Any unapproved repairs or modifications may not only damage the machine and its performance, but could result in severe personal injury. Unapproved repairs or modifications will void warranty and eliminate manufacturer of any liability claims. Consult the equipment manufacturer!!!

Each machine is shipped with a manual, a customer's check sheet on the product, and any available parts & service manuals on component parts not produced by this manufacturer. Additional copies of these manuals and check sheets can be purchased from the manufacturer, or through the dealer. Engine parts, service and maintenance manuals MUST be purchased through the engine manufacturer or their dealer.

NOTICE

The producer of this Bandit product reserves the right to make any modifications or revisions to the design or specifications of its machine without advance notice. The producer also reserves the right to change machine and part prices as needed without advance notice.

EXPLANATION OF LIMITED WARRANTY

The manufacturer will not reimburse the customer or dealer labor costs incurred for installing “bolt-on” or “slip-on” items, such as hydraulic pumps and motors, control valves, flow dividers, belts, sheaves, etc. The manufacturer will provide replacement parts to the customer for defective parts during the warranty period. **Defective parts must be returned to Bandit Industries, Inc.** It will be the customer’s responsibility to install the replacement parts unless arrangements are made with the selling dealer.

The manufacturer will not reimburse travel costs to servicing dealer unless prior approval has been obtained from the manufacturer. It is the customer’s responsibility to deliver the machine to dealer’s service facility, unless other arrangements have been agreed to between selling dealer and customer.

The manufacturer may elect, at its discretion, to reimburse reasonable labor costs to customer or dealer for major defect repairs. Diagnostic labor and overtime labor will not be covered under warranty. Prior approval must be obtained from Bandit Industries, Inc.

There are several forms that must be completely filled out and returned to us in reference to our portion of warranty. Read and understand the Bandit Limited Warranty responsibilities. Some components on your machine are covered by their respective manufacturers and cannot be handled through Bandit Industries as stated in Warranty Section of this manual.

Use this manual to help you resolve what and where your problem is, in most cases you can fix it easily. If you still have problems, work through the dealer you purchased the machine through, or contact Bandit Industries direct if needed.

Make sure the following forms are used, for us as well as you, to keep track of service and pending warranty request. It is our company policy that all parts shipped out will be invoiced until the possible warranty parts are returned with a Warranty Claim Form completed for consideration.

Make sure the Warranty Validation Form is completed and sent in to us as soon as you receive the Bandit. This will activate our warranty responsibilities.

If Warranty Validation Form is not on file, all Warranty consideration is null and void.

NOTICE

Prior to delivery to final owner and during storage, this machine must be serviced and lubricated to avoid damage that will not be covered under warranty, see “Lubrication & Coolant” page.

Also, damage or premature failure of equipment components because of incorrect or incomplete service and maintenance by the equipment owner will not be covered under warranty.

All controls, safety devices, guards, and shields must be correctly operational and securely in place at all times during equipment operation.

BANDIT INDUSTRIES INC. LIMITED WARRANTY

(989) 561-2270

Bandit Industries Inc., also referred to as “Manufacturer” warrants this new product to be free of defects in workmanship and material for a period of 1 year or 2000 operating hours, which ever comes first.

This warranty takes effect upon delivery to the original retail purchaser. The manufacturer at it's option will replace or repair at a point designated by the manufacturer, any parts which appear to have been defective in material or workmanship. The manufacturer is not responsible for labor, consequential damages, traveling or down time expenses.

This warranty and any possible liability of Bandit Industries Inc., is expressly in lieu of any other warranties, expressed or implied, including but not limited to, any implied warranty or merchantability of fitness for a particular purpose and of any noncontractual liabilities including product liabilities based upon negligence or strict liability. Bandit Industries Inc., will not be liable for consequential damages resulting from breach of warranty.

All parties involved agree that the Owner's Sole and Exclusive Remedy against the Manufacturer, whether in contract or arising out of this warranty, instructions, representations, or defects shall only be for the replacement or repair of defective parts as provided herein. In no event or circumstances shall the Manufacturer's liability exceed the purchase price of the machine. The buyer also agrees that no other remedy (including but not limited to consequential or incidental loss) shall be available to him or her.

It is absolutely necessary to return the Warranty Validation Form, completely and accurately filled out, and notify Bandit Industries Inc., in writing within ten (10) days from the date of purchase to validate this warranty. If Warranty Validation Form is not on file, all Warranty Consideration is NULL AND VOID.

This warranty will not apply if the Bandit product is not operated with replacement parts or equipment not manufactured or recommended by Bandit Industries, Inc.

This warranty will not apply if the Bandit product is not operated in a manner recommended by the manufacturer. The following examples would void the warranty:

1. The completed Warranty Validation Form is not on file.
2. The Bandit product has been abused, or not serviced properly.
3. Repairs or attempted repairs made without prior written authorization.
4. Repairs made due to normal wear are not warrantable.
5. The Bandit product was involved in, or damaged by an accident.
6. The Bandit product was damaged from any type of foreign material.

The owner is responsible for all scheduled maintenance as explained in the Operators Manuals. Negligence of proper maintenance or any other negligence, accident or fire; nor with failure to adjust, tighten, or replace wear items included but not limited to items such as teeth, teeth holders, belts, lubrication fluids, bearings, filters, hydraulic components, loose nuts or bolts, etc. may void warranty.

All components and parts being returned to Bandit Industries for warranty consideration must be complete and assembled when delivered. Hydraulic components and parts must be returned assembled with all fluid ports capped or plugged and free of foreign contamination, or warranty will not be considered.

BANDIT INDUSTRIES, INC. LIMITED WARRANTY

(989) 561-2270

NOTICE This warranty applies only to new and unused equipment or parts thereof manufactured by Bandit Industries Inc. and is void if the machine is operated with replacement parts or equipment not manufactured or recommended by Bandit Industries Inc.

All other components are warranted by their respective manufacturers (i.e. engines, axles, hydraulic pumps and motors, clutches, tires, batteries, etc.) Any machines used for lease or rental purposes warranty is limited to 90 days from the first day of initial service.

NOTICE Clutch maintenance and adjustments and engine maintenance (air filter maintenance, oil changes, oil filter maintenance, etc.) are important to your machine. Refer to the clutch or engine manual for the maintenance schedule. Failure to perform the clutch or engine maintenance will void the warranty with the respective manufacturer, Bandit Industries Inc. does not warranty these components!

CONTINENTAL U.S. INFORMATION PHONE NUMBERS FOR ACCESSORIES (NOT COVERED UNDER PRODUCT WARRANTY PROGRAM)

Briggs & Stratton (Vanguard) Engines	1-414-259-5333	PGL Auto Clutch	1-800-551-2938
Caterpillar Engines (Thru 275Hp)	1-800-551-2938	PT Tech Clutch	1-330-414-3172
Caterpillar Engines (300Hp & Up)	1-866-228-2111	NACD, Rockford Clutch	1-800-383-9204
Continental Engines	1-800-726-8870	Twin Disc Clutch	1-262-638-4000
Cummins Engines	1-248-573-1592	Electronic Solutions	1-866-736-6839
Deutz, Lombardini Engines	1-800-445-5273	I.E.C. (formerly E.S.I.)	1-815-985-0383
Ford, Hatz Engines	1-800-726-8870	L.O.R. MFG.	1-866-644-8622
GM, Perkins Engines	1-800-551-2938	Miratron Inc.	1-866-285-0132
Honda Engines	1-734-453-6258	Omnex Radios	1-419-294-4985
John Deere Engines	1-888-803-0549	Kar-Tech, Inc.	1-262-646-9444
Kohler Engines	1-800-854-9273	Dexter Axles	1-574-295-7888
Kubota Engines	1-800-457-7056	Tires	1-989-463-4088
Robin Engines	1-248-399-0002	Caterpillar Tracks	1-309-636-1100
Wisconsin Engines	1-800-726-8870	Chermack Tracks	1-715-458-2655
Interstate Batteries	1-989-684-1382	Petro-Canada Hydrex XV	1-888-284-4572

(Phone numbers for outside the continental U.S. can be supplied from your phone directory or local Bandit dealer.)

In order to process any warranty claims, it is the owner's responsibility to report the claims promptly to the Manufacturer, or our authorized dealer from whom the equipment was purchased.

It is necessary to include the following information on any and all requests for warranty:

1. Warranty Claim Form, obtained from Bandit Industries or it's dealers, completely and accurately filled out.
2. Dealer from whom purchased.
3. Date of delivery.
4. Serial number of unit.
5. Model number of unit.
6. Engine make and serial number.
7. Length of time in use (hours on machine).
8. Date of failure.
9. Nature of failure.

Bandit Industries Inc., reserves the right to alter, improve, revise or modify any parts or products with the altered, improved, revised or modified parts or products. They also may change design, specifications, or part prices without advance notice.

Bandit Industries Inc., is NOT responsible for updating or upgrading completed machines with design changes that are made after it's production.

Bandit Industries Inc., expects the Customer/Owner to bring their machine to the Dealer/Manufacturer for Warranty Repairs. The Manufacturer DOES NOT pay Dealers or Customers for bringing their machine in for repair. Nor does the Manufacturer furnish loaner machines while the unit is being repaired.

TYPICAL SERIAL NUMBER AND/OR WORK ORDER NUMBER LOCATIONS





1. Side of control box
2. W/O # on pivot mount plate

NOTICE

The engine information is located on the engine block. The clutch information is located on the clutch plate (if equipped).

SAFETY PROCEDURES

DANGER

The words  Danger,  Warning,  Caution, and Notice are used on the safety decals and throughout this manual, to make you aware of the safety procedures. These procedures are very important, read and obey them.

YOUR SAFETY IS VERY IMPORTANT TO US!

This machine is equipped with safety decals, guards and designs for your protection.

Don't ever take the machine for granted, always be cautious and careful when operating your equipment.

Read and follow all the instructions in your manual thoroughly. Your safety is dependent on your knowledge of how to operate and maintain this machine. You may obtain additional copies of this manual from your Bandit Dealer.

Before operating machine, you must have all potential operators; read and understand manuals and decals, watch the video and follow the recommendations.

Regardless of how hard a manufacturer tries to produce a safe machine, accidents still happen. Normally accidents are caused by people making mistakes. They do not read the manual, they ignore warning decals or do not use lockouts provided for their safety. This normally happens after the person has become accustomed to the machinery. In the initial start up and operation of the machinery, they are cautious, they are very careful because they do not understand the machine.

This equipment is intended for use by personnel who are experienced with similar equipment. Always operate safely. There should be at least two qualified and trained operators at the work site. They should be positioned in safe working locations, following safety procedures and instructions, and aware of each others whereabouts. There should, also, be at least two people on site during maintenance and service procedures in case an accident should occur. Never operate any machine while under the influence of drugs or alcohol.

Keep children, bystanders and animals clear of working area. Never operate equipment that is in need of repair or adjustment.

DANGER

Before starting the machine, take a minute to check a few things. The grinder should be in an area restricted from people passing by. This area around the grinder must be free of all objects that can obstruct your movement when working with the grinder. The machine should be checked for loose tools or foreign objects, especially in the grinding area. All tools not in use should be secured in a tool box.

DANGER

NEVER sit, stand, lay, climb or ride anywhere on this machine while it is running, operating, or in transit. You will be injured.

WARNING

Operators must at all times be located within easy reach of all control and shut-off devices when the unit is running. They must be attentive and prepared to activate the devices.

DANGER

Torn or loose clothing is more likely to get caught in moving machinery parts. Keep such items as long hair, shirt sleeves, and shirt tails properly contained. Avoid wearing necklaces, rings, watches, and especially neckties while operating this machinery. Make sure the machine is in excellent condition, and all the guards are in place, tight and secure.

Wear all personal protection equipment and follow all safety standards per ANSI and OSHA instructions. Examples of equipment: hard hat, face shield, safety glasses, gloves, ear protection, etc. Always keep a fully charged fire extinguisher with the machine while operating or servicing the machine.

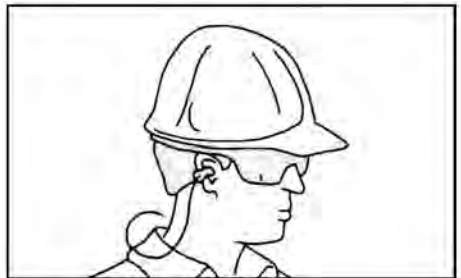

WARNING



WEAR EYE & PERSONAL PROTECTION EQUIPMENT

Wear all personal protection equipment and follow all safety standards per ANSI and OSHA instructions.

SAFETY PROCEDURES

WARNING

It is very important after you have operated a new machine for approximately an hour to shut down the machine and recheck all nuts and bolts. It is normal for nuts and bolts to loosen once on a new piece of machinery. If you tighten them now, there is a good possibility they won't loosen again. Certain nuts and bolts should be checked periodically such as cutter teeth bolts, etc. for torque and fit.

Most of the nuts used on the Bandit Grinder are self locking. After a nut or bolt has been removed five times, it should be replaced to ensure proper tightness. This is especially critical on the cutter tooth bolts!

After the engine is started, let the grinder wheel turn at the lowest RPM's possible. Listen for any type of noise that is foreign. Any steel on steel noise is foreign. If you hear a noise, stop the engine, find the problem and fix it.

WARNING

It is very important after you have operated a new machine for approximately an hour to shut down the machine and recheck all hydraulic fittings. Retighten as needed.

DO NOT GO NEAR HYDRAULIC LEAKS! High pressure oil easily punctures skin causing serious injury, gangrene, or death. Avoid burns from fluid. Hot fluid under pressure can cause severe burns. DO NOT use fingers or skin to check for leaks. Lower load or relieve hydraulic pressure before loosening fittings. Relieve all pressure in the system before disconnecting the lines, hoses, or performing other work. Use a piece of cardboard to find leaks. Never use your bare hands. Allow system to cool down to ambient temperature before opening any coolant or hydraulic oil system.

In cold weather situations let your hydraulic system idle for approximately 15 minutes to allow the system to warm up to operating temperature.

WARNING

DO NOT operate this machine unless all hydraulic control devices operate properly. They must function, shift and position smoothly and accurately at all times. Faulty controls can cause personal injury!

DANGER

Keep the machine in good condition. Be sure the machine is in good operating condition and that all safety devices, including guards and shields are installed and functioning properly. Visually inspect the machine daily before starting the machine. Refer to the "Daily Start Up & Maintenance". Make no modifications to your equipment unless specifically recommended or requested by Bandit Industries Inc.

DANGER

DO NOT operate this machine indoors! Exhaust fumes can be fatal. Never refuel while the machine is running. Never refuel in the shop or building. Always refuel in a well ventilated area, away from sparks or open flames, DO NOT SMOKE. Extinguish all smoking materials. Wipe up all spilled fuel before restarting the engine. Do not fill above 1/2" (12.7mm) from top of tank.

To obtain the most from your machine, for the least amount of cost, it is a good practice to set up and follow a scheduled preventative maintenance program. It will eliminate many possible problems and down time.

CALIFORNIA

Proposition 65 Warning

Diesel engine exhaust and some of its constituents are known to the State of California to cause cancer, birth defects, and other reproductive harm.

WARNING

Never use jumper cables during freezing temperatures. Tow the machine inside and allow the battery time to warm up. If the machine must be started outside, inspect the battery acid for ice formation. Explosion will occur with a frozen battery. If the machine is going to be operated in excessively cold conditions, a larger cold cranking amp battery may be needed to ensure proper and prompt starting. Never use jumper cables in a confined or unventilated area. Battery acid fumes are explosive. Battery acid can cause severe burns. Never expose an open flame or spark near the battery. Keep all burning materials away from the battery. When servicing the battery, shield eyes and face, and do not smoke. Service in a well ventilated area.

DANGER

Before attempting any type of maintenance disengage clutch, turn off engine, wait for the cutter wheel to come to a complete stop, install the cutter wheel lock pin, disconnect battery, and make sure the ignition key is in your possession.

ALWAYS install the lock pin into the cutter lock tube before working on the grinder.

Simply slide the lock pin into the cutter wheel lock tube. This is to ensure that the cutter wheel cannot be started while you are working on the grinder. If for some reason the cutter wheel would start to turn, it would simply hit the lock pin.

SAFETY PROCEDURES

NOTICE

Engage and disengage cutter wheel at low rpm.

NOTICE

Do not attempt to start the engine or engage the engine PTO (power-take-off) system on this machine if the cutter wheel is jammed or frozen in place. If you do, you will damage or ruin the drive belts and/or the PTO which will not be covered under warranty and will cost you down time and money.

DANGER

Your machine may or may not be equipped with a clutch. Depending on the options ordered, some may be direct drive.

Do not work on the machine if the engine is running with the clutch disengaged. A clutch can self engage if either the pilot or throw-out bearing happens to seize to the main output shaft.

There are various types of clutches (PTO's) available for this type of equipment. Make sure to study the original clutch manufacturer's manual that is provided with the machine and follow its instructions for operation, service, and adjustments. Some styles require clutch engagement to be maintained so that it takes a lot of force, others will require very little force, and some are push button, electric, manual lever, or hydraulic activation. Each different style clutch (PTO) is a very expensive item that will fail if not correctly maintained and adjusted. It will be quite costly if a few minutes are not taken daily, weekly, and monthly to keep the clutch serviced as required.

The operator must take care in the engagement and disengagement of the clutch, engine RPM should always be below 1000 RPM. When the engine has sufficiently warmed up, bump the clutch handle against engagement to start the cutter wheel turning. This will have to be repeated until the cutter wheel is turning at proper ratio with engine RPM. Then push the handle all the way in gear until it locks into position securely. After engagement raise engine RPM to full throttle. Engaging and disengaging the clutch at high engine RPM will quickly and excessively wear out clutch plates as well as bearings. Refer to clutch manufacturer's manual for proper service and operation.

DANGER

Avoid moving parts. Keep hands, feet, and clothing away from power driven parts. Keep all guards and shields in place and properly secured.

DANGER

Do not go near or in-line with the debris field of the stump grinder while in operation. While grinding stumps, the chips and portions of the stump fly from the cutter wheel and can cause severe injury.

DANGER

Never go near cutter wheel or teeth while engine is running or cutter wheel is coasting to a stop.

DANGER

Never grind materials that might contain wires, stones, nails, or other metal objects which may damage the teeth and become dangerous projectiles. Remove all rocks and stones from stump grinding area.

DANGER

Do Not start to grind a stump unless you are completely sure there are not any power lines, water lines, sewer lines, phone lines, etc. in the area above or below the ground level where you are grinding.

WARNING

CLEAN MACHINE OF ALL DEBRIS! DO NOT leave this machine unattended until all potential fire debris is removed, no fire or smoldering exists, and hot spots are cold. The engine creates many hot spots including: exhaust manifold, exhaust, turbo (if equipped), etc. Remove all flammable debris such as wood, chips, leaves, oils, fuels, etc. from engine exhaust, engine turbo (if equipped), beside, around, and under engine, around and under tanks, inside belt shields and guards, inside battery and tool boxes, inside cabinets (if equipped), and anywhere materials collect. ALWAYS keep several type A:B:C fire extinguishers operational and on the job at all times.

WARNING

Check laws and regulations. Know and obey all federal, state, and local laws and regulations that apply to your work situation and the transportation of a machine this size.

WARNING



Sparks can occur if cutter teeth strike rocks, metal, or other hard objects.

DO NOT use in high or very high fire hazard severity zones.

Operation of this equipment may create sparks that can start fires around dry vegetation. A spark arrester may be required. The operator should contact local fire agencies for laws or regulations relating to fire prevention requirements.

WARNING

Do Not continue to operate the machine if the cutter wheel stalls. Immediately lift cutter wheel out of the stump, dirt, etc. and start again with less bite. Prolonged cutter wheel stall will ruin the hydraulic components, creating extreme heat and possible fire hazard.

SAFETY PROCEDURES

IF MACHINE IS EQUIPPED WITH A SELF PROPELLED UNDERCARRIAGE

Machines equipped with undercarriage tracks are shipped with a manual from the track manufacturer. Refer to it for service, operation, and safety information.

⚠ WARNING

Do not attempt to operate the machine on an ascending or descending slope of more than 25° or 46% or a side slope of more than 17° or 30%, it is Dangerous and could be Fatal. This is the maximum slope grade the machine can be operated on if the hydraulic system, self propelled undercarriage, and engine are running at maximum performance and good traction is sustained.

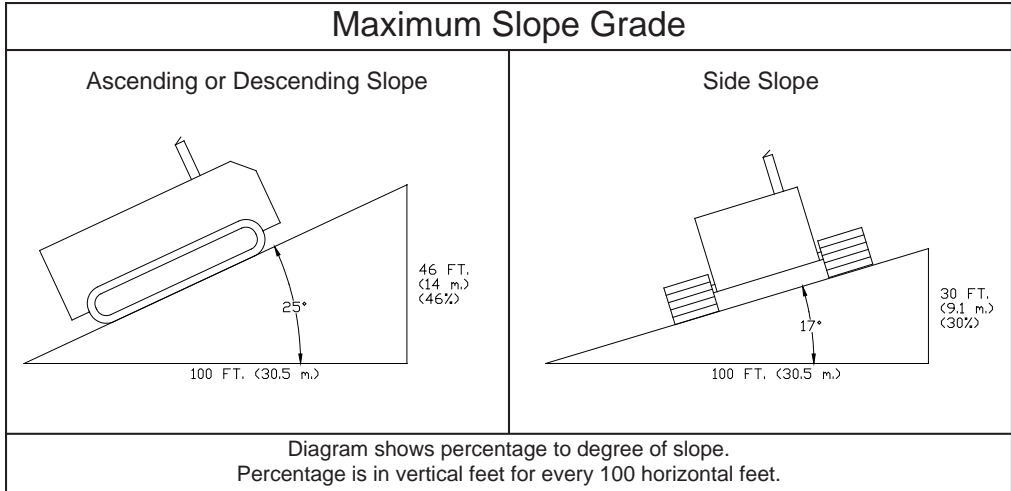

⚠ WARNING

Any increase from the specified maximum operating angles may cause loss of lubrication function and damage the engine.

⚠ DANGER

The machine should never be parked on a slope at any time. The machine can coast or creep causing equipment and/or personal injury.

⚠ DANGER

Make sure everyone is clear of machine before moving the machine. Stay clear of undercarriage travel system when the machine is moving.

⚠ DANGER

DO NOT entangle feet or hands in undercarriage travel system.

⚠ DANGER

Use **EXTREME CAUTION** when traveling over non-level surface! This machine can tip over or tip backwards on non-level surface. You will cause engine damage, machine damage and possible personal injury!

⚠ DANGER

NEVER sit, stand, lay, climb or ride anywhere on this machine while it is running, operating, or in transit. You will be injured.

EQUIPMENT SPECIFICATIONS



Approximate Dimensions & Weights

(Dimensions & weights will vary depending on optional equipment)

Approx.
Weight: Model 2550: 2200 lbs. (998 kg)
Model 2550T: 2600 lbs. (1179 kg)

(Approximate weights depending on engine and equipment options.)

Overall Dimension:	Model 2550:	Height: 72" (1.83 m), 55" (1.40 m) - Remote Control Machine	Length: 122" (3.10 m), 118" (3.0 m), 55" (1.40 m) - Remote Control Machine	Width: 35" (.89 m)
	Model 2550T:	Height: 72" (1.83 m), 55" (1.40 m) - Remote Control Machine		Width: 35" (.89 m)

Cutting Depth: 15" (.38 m)

Cutting Height: 23" (.58 m)

Cutting Swing: 53" (1.35 m)

Number of Teeth
on Cutter Wheel: 18

Cutter Wheel
Diameter with Teeth: 21" (.53 m)

Fuel Tank Capacity: 8 Gallons (30 Liters)
Hydraulic Tank Capacity: 8 Gallons (30 Liters)

(Approximate dimension depending on equipment options.)

DECAL LOCATIONS

Decal locations may vary, these are general locations.

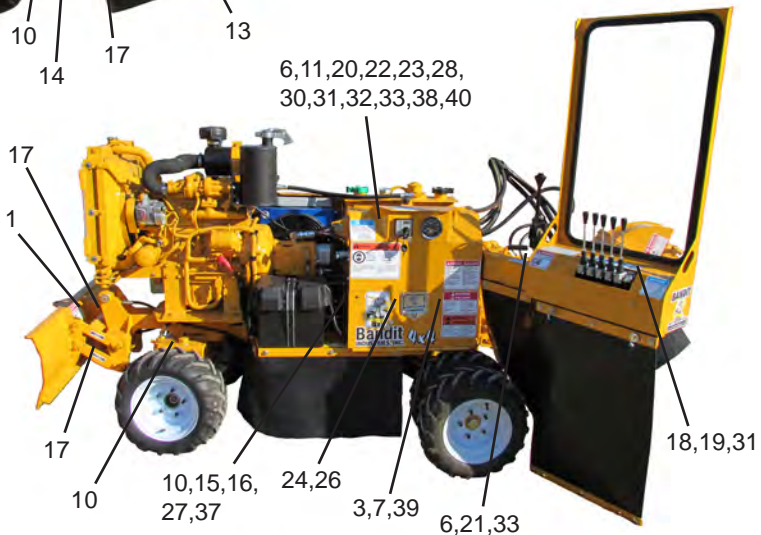
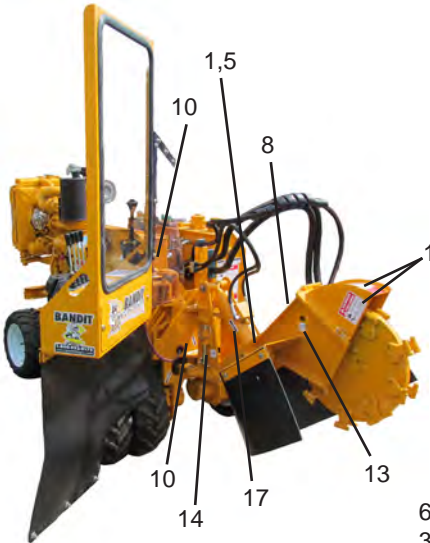
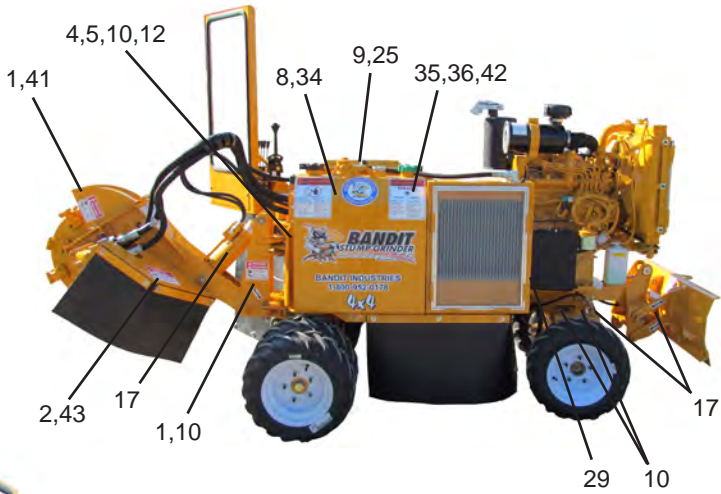

DECAL LOCATIONS

Modifications and/or additions of decals to this list will happen.
Consult chipper dealer or manufacturer for most current decal package.

LOCATION	NUMBER	DESCRIPTION
1.	SPD-02	Moving Parts...
2.	SPD-20	Flying Objects Stand Clear...
3.	SPD-30	Do Not Sit, Stand, Lay, Climb...
4.	SPD-35	Extreme Caution...Non-Level Surface...
5.	SPD-36	...Debris Field...
6.	SPD-38	Do Not Entangle Feet...
7.	SPD-39	Do Not Operate...
8.	ID-42	Bandit Industries Inc...USA
9.	INST-04	Arrow
10.	INST-12	Grease Daily (Arrow)
11.	INST-44	California Proposition 65
12.	INST-53	Hydraulic Oil...Hydrex XV...
13.	INST-73	Cutter Head Lock Hole
14.	INST-74	Cutter Head Lock Pin
15.	INST-81	Swing Speed - Clockwise To Slow
16.	INST-82	Travel Speed - Clockwise To Slow
17.	INST-86	Grease Daily - Double Arrow
18.	INST-88	Controls - 4 Function
19.	INST-89	Controls - 5 Function
20.	INST-101	Canada Engine Decal
21.	INST-110	Window Washing Instructions...
22.	INST-136	Remote Starting Procedures - Omnex
23.	INST-137	Remote / Tether
24.	INST-151	Brake Release Procedure
25.	INST-152	Turn Ball Valve...To Release Brakes
26.	INST-153	Brake Release Hand Pump
27.	INST-161	Turn Brake Release...To Free Brakes
28.	INST-214	Remote Starting Procedures - Kar-Tech / LOR
29.	N-02	Maintain Lubrication...
30.	SPN-06	Decal Maintenance...
31.	N-33	Engine Oil Lubrication...Break-In...
32.	N-43	...Oil Cooler Fan Starts...
33.	N-44	Engage And Disengage...At Low RPM
34.	SPW-01	Do Not Go Near Oil Leaks...
35.	SPW-02	Diesel Fuel Only
36.	SPW-03	Gasoline Fuel Only...
37.	SPW-04	Frozen Battery Can Explode...
38.	SPW-08	Wear Personal Protection...
39.	SPW-09	...Go Slow Around Corners...
40.	SPW-28	...Fire Hazard...
41.	SPW-29	...Cutter Wheel Stall...
42.	SPW-31	Explosion Hazard...
43.	SPW-32	...Tether Cord...
44.	900-8900-34	Basic Safety Decal Kit (Options may require additional decals)
45.	900-8901-97	Bandit Model 2550 Logo Decal Kit
46.	900-8902-81	Bandit Model 2550T Logo Decal Kit

NOTICE

Some decals are for optional equipment. Decal locations may vary, these are general locations. If any decals become damaged, replace immediately.

DECALS

Decals located on your Bandit equipment contain useful information to assist you in operating your equipment safely. Some of the decals on your machine and their location are shown in this section.

It is very important that all decals remain in place and in good condition on your machine. Please follow the care and instructions given below:

1. You should use soap and water to keep your decals clean. Never use mineral spirits or any other abrasive cleaners.
2. Replace immediately any missing or damaged decals. The location the decal is going to be applied to must be clean and dry, and at least 40°F (5°C) before applying decal.
3. When the need arises to replace a machine component with a decal attached, be sure and replace the decal.
4. Replacement decals are available, and can be purchased from the manufacturer or your Bandit Dealer.
5. Peel back about half of the backer paper on the decal. Position it on the flat, dry, clean surface so it is smooth and secure. Peel off the remainder of the backer paper as you continue to stick the decal on the surface.
6. Rub decal from the center outward to remove air bubbles and to secure contact.
7. Combination English / Spanish decals are typically standard. Other foreign language decals are available and may be purchased. Mail translated decals required to Bandit Industries, Inc.

EXAMPLES:



ENGINE OPERATING SPEEDS

NOTICE Refer to the Completion/Check Sheet, that is shipped with the machine for the correct engine rpm. If needed, contact your local dealer or Bandit Industries.

Some Current Engine Types	Maximum RPM
Briggs & Stratton (Vanguard) 613477 - 35 Hp	3600
Kohler CH980 - 38 Hp	3600
Kubota V1505T - 44.2 Hp	3000

CONTROLS & COMPONENTS

Basic Location of Controls and Components

LOCATION SHOWN

- | | |
|-------------------------------|--|
| 1. Hydraulic Tank | 6. Cutter Wheel Teeth |
| 2. Fuel Tank | 7. Engine Controls (varies with engines) |
| 3. Oil Cooler Fan | 8. Tach / Hour Meter |
| 4. Cutter Wheel Lock Pin | 9. Control Box |
| 5. Cutter Wheel Lock Pin Hole | |



2550 CONTROLS - SWING OUT

Basic Location of Controls and Components

LOCATION SHOWN

1. Swing Speed Control
2. Travel Speed Control
3. Brake Release Valve
4. Cutter Wheel Engagement Lever
5. Steer Right / Left
6. Travel Forward / Reverse
7. Cutter Down / Up
8. Grading Blade Down / Up
9. Swing Left / Right
10. Swing Out Lock Pin
11. Tach / Hour Meter
12. Ignition Switch

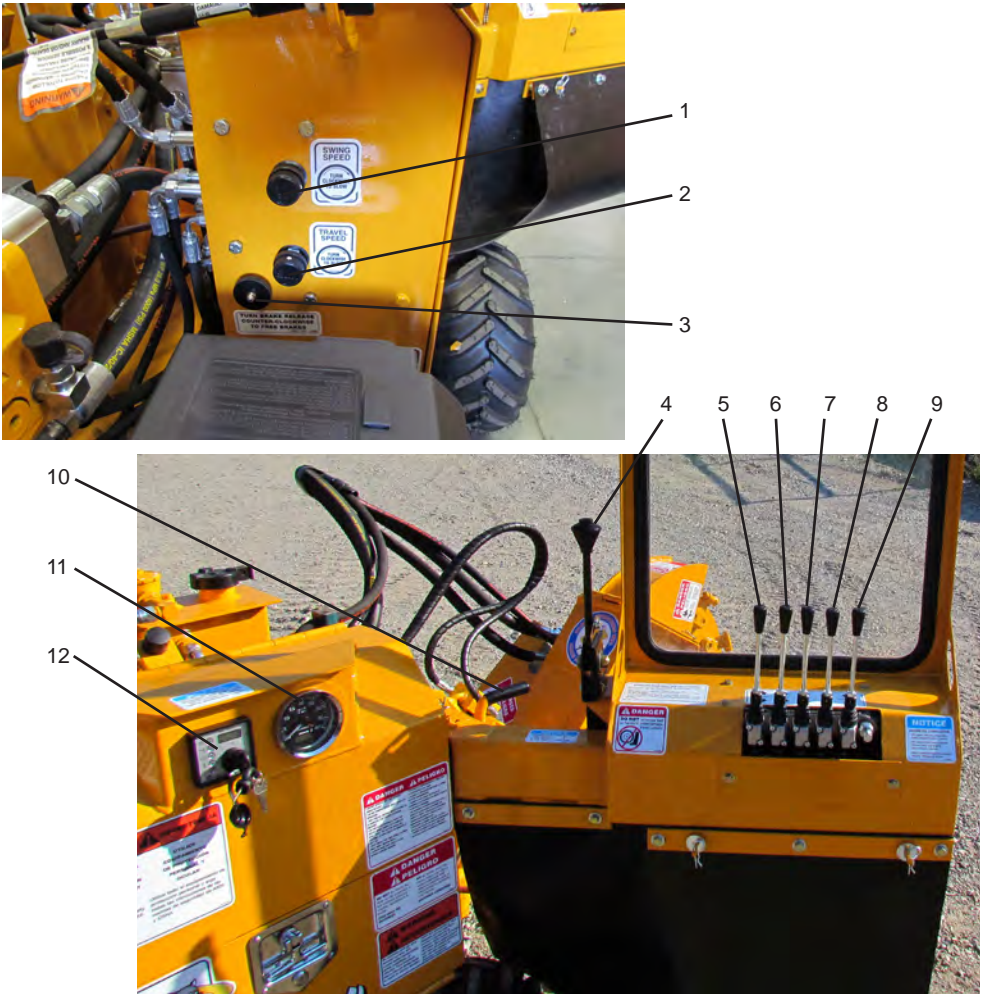

CONTROL OPERATING PROCEDURES - SWING OUT

1. Swing Speed Control:

The swing speed controls the rate the cutter wheel passes through the stump. To decrease the swing speed, turn the control knob clockwise.

2. Travel Speed Control:

The travel speed controls the rate the machine approaches the stump. To decrease the travel speed, turn the control knob clockwise.

3. Brake Release Valve:

Turn 3 to 4 full revolutions when moving the machine without power.

4. Cutter Wheel Engagement Lever:

Before engaging or disengaging the cutter wheel, make sure the engine is at an idle. To engage the cutter wheel, press the button on top of the lever and pull the lever, towards the operator. To disengage the cutter wheel, press the button on top of the lever and push the lever, away from the operator.

5. Steer Right / Left:

To steer the machine to the right, push the handle, away from the operator. To steer the machine to the left, pull the handle, towards the operator. The steering is stationary when the handle is in the center location.

6. Travel Forward / Reverse:

To move the machine forward, push the handle away from the operator. To reverse the machine, pull the handle towards the operator. The machine is stationary when the handle is in the center location.

7. Cutter Down / Up:

To lower the cutter wheel, push the handle away from the operator. To lift the grading blade, pull the handle towards the operator. The grading blade is stationary when the handle is in the center location.

8. Grading Blade Down / Up:

To lower the grading blade, push the handle away from the operator. To lift the cutter wheel, pull the handle towards the operator. The cutter wheel lift is stationary when the handle is in the center location.

9. Swing Left / Right:

To swing the cutter wheel to the left, push the handle, away from the operator. To swing the cutter wheel to the right, pull the handle, towards the operator. The swing is stationary when the handle is in the center location.

10. Swing Out Lock Pin:

Lock the swing out lock pin into the operating position or the transport position.

11. Tach / Hour Meter:

Displays the engine rpm and number of hours the engine has been on. Varies with engines and options.

12. Ignition Switch:

Location varies with different engine options.

2550 CONTROLS - REMOTE

Basic Location of Controls and Components

LOCATION SHOWN

- | | | |
|----------------------------------|-----------------------------|----------------------------|
| 1. Engine Throttle | 8. Swing Speed Control | 16. Steer Right / Left |
| 2. Remote / Tether Switch | 9. Brake Release Valve | 17. Tongue Out / In |
| 3. Ignition Switch | 10. Travel Speed Control | 18. Status Light |
| 4. Tach / Hour Meter | 11. Cutter Down / Up | 19. Cutter Bump Adjustment |
| 5. Link Light | 12. Swing Left / Right | 20. Power On / Off |
| 6. Tether Plug Jack | 13. Drive Forward / Reverse | 21. Batteries |
| 7. Cutter Wheel Engagement Lever | 14. Blade Down / Up | 22. Battery Status Light |
| | 15. Engine Stop | |

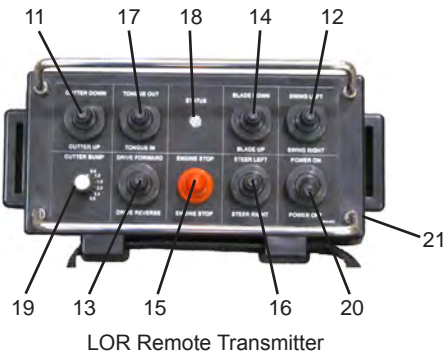
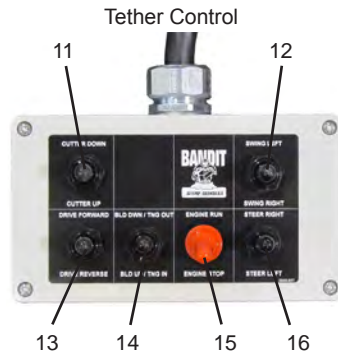
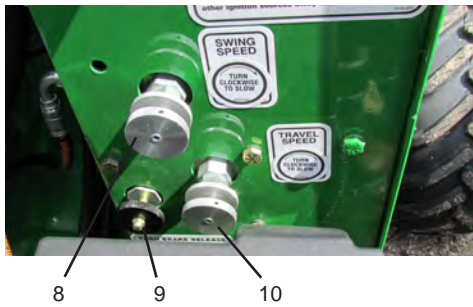
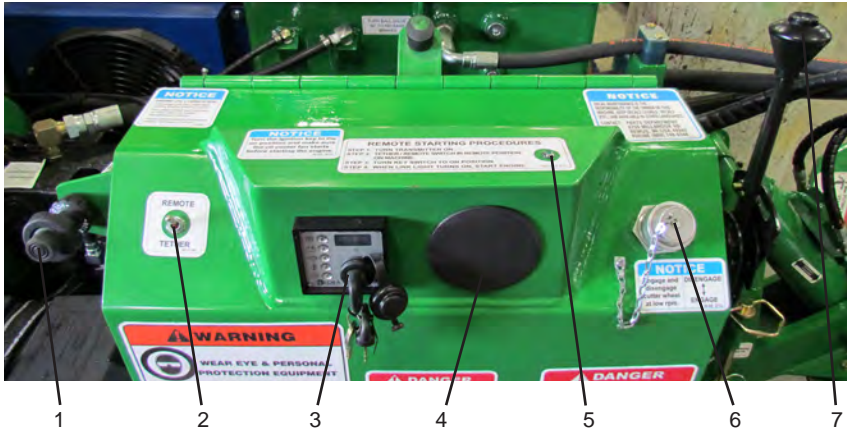

CONTROL OPERATING PROCEDURES - REMOTE

1. **Engine Throttle:** Varies with different engines, refer to engine manual.
2. **Remote / Tether Switch:** If the switch is in the remote position, the machine is controlled by the transmitter. If the switch is in the tether position and the tether cord is plugged in to the jack, the machine is controlled by the tether.
3. **Ignition Switch:** Location varies with different engine options.
4. **Tach / Hour Meter** (not shown): Displays the engine rpm and number of hours the engine has been on. Varies with engines and options.
5. **Link Light:** If the transmitter is linked to the machine the link light will be on.
6. **Tether Plug Jack:** Plug the tether cord in here to control the machine if the batteries in the remote control run out of power or the remote is not working.
7. **Cutter Wheel Engagement Lever: Before engaging or disengaging the cutter wheel, make sure the engine is at an idle.** To engage the cutter wheel, press the button on top of the lever and pull the lever, towards the operator. To disengage the cutter wheel, press the button on top of the lever and push the lever, away from the operator.
8. **Swing Speed Control:** The swing speed controls the rate the cutter wheel passes through the stump. To decrease the swing speed, turn the control knob clockwise.
9. **Brake Release Valve:** Turn 3 to 4 full revolutions when moving the machine without power.
10. **Travel Speed Control:** The travel speed controls the rate the machine approaches the stump. To decrease the travel speed, turn the control knob clockwise.
11. **Cutter Down / Up:** To lower the cutter wheel, push the switch away from the operator. To lift the cutter wheel, pull the switch towards the operator. The cutter wheel lift is stationary when the switch is in the center location. When using a transmitter, if you hit and release the lift down switch, the cutter wheel will drop a certain distance that is adjustable using the cutter bump adjustment.
12. **Swing Left / Right:** To swing the cutter wheel to the left, push the switch, away from the operator. To swing the cutter wheel to the right, pull the switch, towards the operator. The swing is stationary when the switch is in the center location.
13. **Drive Forward / Reverse:** To move the machine forward, push the switch away from the operator. To reverse the machine, pull the switch towards the operator. The machine is stationary when the switch is in the center location.
14. **Grading Blade Up / Down (Optional):** If equipped, to lower the grading blade, push the switch away from the operator. To lift the grading blade, pull the switch towards the operator. The grading blade is stationary when the switch is in the center location.
15. **Engine Stop Switch:** Shuts off the power to the engine and to the hydraulic valve. The engine stop switch must be in the run position on the tether control or the center position on the remote transmitter for the engine to start.
16. **Steer Right / Left:** With the remote transmitter, to steer the machine to the left, push the switch, away from the operator. To steer the machine to the right, pull the switch, towards the operator. The steering is stationary when the switch is in the center location.
With a tether control, to steer the machine to the right, push the switch, away from the operator. To steer the machine to the left, pull the switch, towards the operator. The steering is stationary when the switch is in the center location.
17. **Tongue Out / In:** Not used on this model.
18. **Status Light:** If the transmitter is working properly the status light will be green and flashing. See the LOR manual for further information.
19. **Cutter Bump Adjustment:** Turn the knob clockwise to increase the distance the cutter wheel drops when you hit the cutter wheel up and down or lift control switch and counter-clockwise to decrease the cutter wheel drops.
20. **Power On / Off Switch:**
To switch the remote transmitter to on, push the switch away from the operator. To switch the remote transmitter to off, pull the switch towards the operator.
21. **Batteries:** LOR remote transmitters require (4) AA batteries.
22. **Batteries Status Light:** Kar-Tech remote will have a blinking red light when battery is getting low.

2550T CONTROLS - SWING OUT

Basic Location of Controls and Components

LOCATION SHOWN

1. Travel Speed Control
2. Swing Speed Control
3. Cutter Wheel Engagement Lever
4. Left Track Forward / Reverse
5. Right Track Forward / Reverse
6. Cutter Down / Up
7. Grading Blade Down / Up
8. Swing Left / Right
9. Swing Out Lock Pin
10. Tach / Hour Meter
11. Ignition Switch

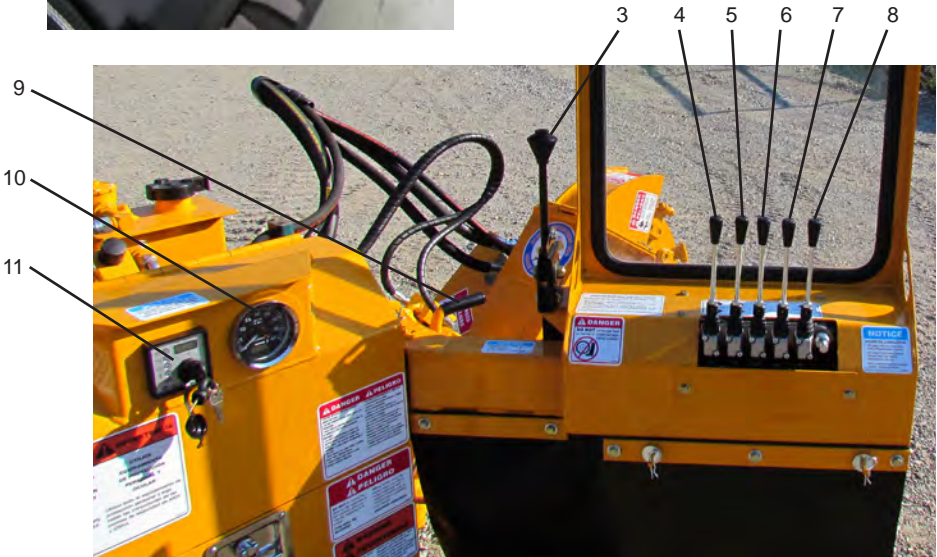

CONTROL OPERATING PROCEDURES - SWING OUT

1. Travel Speed Control:

The travel speed controls the rate the machine approaches the stump. To decrease the travel speed, turn the control knob clockwise.

2. Swing Speed Control:

The swing speed controls the rate the cutter wheel passes through the stump. To decrease the swing speed, turn the control knob clockwise.

3. Cutter Wheel Engagement Lever:

Before engaging or disengaging the cutter wheel, make sure the engine is at an idle. To engage the cutter wheel, press the button on top of the lever and pull the lever, towards the operator. To disengage the cutter wheel, press the button on top of the lever and push the lever, away from the operator.

4. Left Track Forward / Reverse:

To move the left track forward, push the handle away from the operator. To reverse the left track, pull the handle towards the operator. The track is stationary when the handle is in the center location.

5. Right Track Forward / Reverse:

To move the right track forward, push the handle away from the operator. To reverse the right track, pull the handle towards the operator. The track is stationary when the handle is in the center location.

6. Cutter Down / Up:

To lower the cutter wheel, push the handle away from the operator. To lift the grading blade, pull the handle towards the operator. The grading blade is stationary when the handle is in the center location.

7. Grading Blade Down / Up:

To lower the grading blade, push the handle away from the operator. To lift the cutter wheel, pull the handle towards the operator. The cutter wheel lift is stationary when the handle is in the center location.

8. Swing Left / Right:

To swing the cutter wheel to the left, push the handle, away from the operator. To swing the cutter wheel to the right, pull the handle, towards the operator. The swing is stationary when the handle is in the center location.

9. Swing Out Lock Pin:

Lock the swing out lock pin into the operating position or the transport position.

10. Tach / Hour Meter:

Displays the engine rpm and number of hours the engine has been on. Varies with engines and options.

11. Ignition Switch:

Location varies with different engine options.

2550 CONTROLS - REMOTE

Basic Location of Controls and Components

LOCATION SHOWN

- | | | |
|----------------------------------|----------------------------------|-----------------------------------|
| 1. Engine Throttle | 8. Travel Speed Control | 15. Right Track Forward / Reverse |
| 2. Remote / Tether Switch | 9. Swing Speed Control | 16. Status Light |
| 3. Ignition Switch | 10. Cutter Down / Up | 17. Cutter Bump Adjustment |
| 4. Tach / Hour Meter | 11. Swing Left / Right | 18. Battery Status Light |
| 5. Link Light | 12. Left Track Forward / Reverse | 19. Power On / Off |
| 6. Tether Plug Jack | 13. Blade Down / Up | |
| 7. Cutter Wheel Engagement Lever | 14. Engine Stop | |

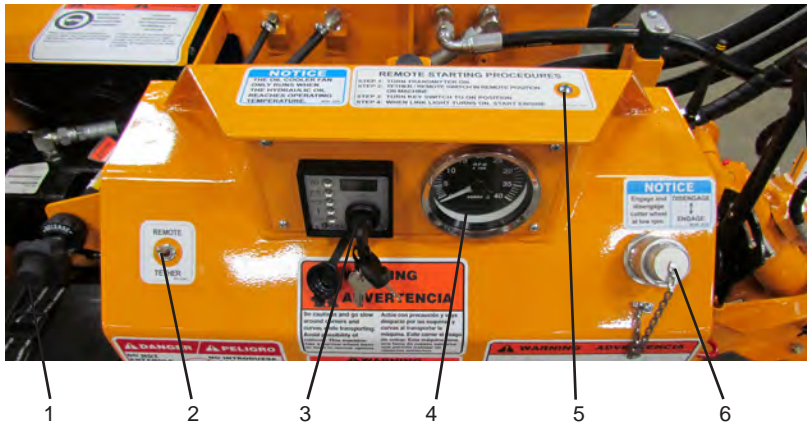

Tether Control



KAR-TECH Remote Transmitter

NOTICE

- To link the transmitter and the machine:
1. Switch the transmitter power on
 2. Switch the TETHER / REMOTE switch on the machine to the REMOTE position
 3. Turn the ignition key to the ON position
 4. When the machine link light turns on, start engine.

CONTROL OPERATING PROCEDURES - REMOTE

1. **Engine Throttle:** Varies with different engines, refer to engine manual.
2. **Remote / Tether Switch:** If the switch is in the remote position, the machine is controlled by the transmitter. If the switch is in the tether position and the tether cord is plugged in to the jack, the machine is controlled by the tether.
3. **Ignition Switch:** Location varies with different engine options.
4. **Tach / Hour Meter** (not shown): Displays the engine rpm and number of hours the engine has been on. Varies with engines and options.
5. **Link Light:** If the transmitter is linked to the machine the link light will be on.
6. **Tether Plug Jack:** Plug the tether cord in here to control the machine if the batteries in the remote control run out of power or the remote is not working.
7. **Cutter Wheel Engagement Lever: Before engaging or disengaging the cutter wheel, make sure the engine is at an idle.** To engage the cutter wheel, press the button on top of the lever and pull the lever, towards the operator. To disengage the cutter wheel, press the button on top of the lever and push the lever, away from the operator.
8. **Travel Speed Control:** The travel speed controls the rate the machine approaches the stump. To decrease the travel speed, turn the control knob clockwise.
9. **Swing Speed Control:** The swing speed controls the rate the cutter wheel passes through the stump. To decrease the swing speed, turn the control knob clockwise.
10. **Cutter Down / Up:** To lower the cutter wheel, push the switch away from the operator. To lift the cutter wheel, pull the switch towards the operator. The cutter wheel lift is stationary when the switch is in the center location. When using a transmitter, if you hit and release the lift down switch, the cutter wheel will drop a certain distance that is adjustable using the cutter bump adjustment.
11. **Swing Left / Right:** To swing the cutter wheel to the left, push the switch, away from the operator. To swing the cutter wheel to the right, pull the switch, towards the operator. The swing is stationary when the switch is in the center location.
12. **Left Track Forward / Reverse:** To move the left track forward, push the switch away from the operator. To reverse the left track, pull the switch towards the operator. The left track is stationary when the switch is in the center location.
13. **Grading Blade Up / Down (Optional):** If equipped, to lower the grading blade, push the switch away from the operator. To lift the grading blade, pull the switch towards the operator. The grading blade is stationary when the switch is in the center location.
14. **Engine Stop Switch:** Shuts off the power to the engine and to the hydraulic valve. The engine stop switch must be in the run position on the tether control or the center position on the remote transmitter for the engine to start.
15. **Right Track Forward / Reverse:** To move the right track forward, push the switch away from the operator. To reverse the right track, pull the switch towards the operator. The right track is stationary when the switch is in the center location.
16. **Status Light:** If the transmitter is working properly the status light will be green and flashing. See the LOR manual for further information.
17. **Cutter Bump Adjustment:** Turn the knob clockwise to increase the distance the cutter wheel drops when you hit the cutter wheel up and down or lift control switch and counter-clockwise to decrease the cutter wheel drops.
18. **Batteries Status Light:** Kar-Tech remote will have a blinking red light when battery is getting low.
19. **Power On / Off Switch:**
To switch the remote transmitter to on, push the switch away from the operator. To switch the remote transmitter to off, pull the switch towards the operator.

CONSULT THE ENGINE MANUFACTURER'S MANUAL FOR SPECIFIC CONTROLS, OPERATION, & MAINTENANCE FOR TYPICAL ENGINES

1. **Ignition Switch:** Turn the ignition switch key clockwise one stop (on position) to turn the electrical system on. The key should remain in the on position while the engine is running. Turn the key fully clockwise (start position) this will start the engine. To shut off the engine, return the key to the off position.
2. **On/Off Switch - Push Button Start:** Some gasoline engines may have a Toggle Switch or an On/Off Switch combined with a push button to start the engine. First turn the On/Off Switch or Toggle Switch to the on position, then depress and hold the Push Button Start until the engine starts, then release the button. To shut off the engine, return the On/Off Switch or Toggle Switch to the off position.
3. **Ignition Switch With Preheat:** The typical diesel engine may have a preheat system to assist in starting the engine during cold weather. To activate the preheat system, continue to hold the ignition key in the preheat position for 15 to 20 seconds, then attempt to start the engine. If the engine fails to start within 15 seconds, return the key to the preheat position, hold 10 seconds, and try starting again.
4. **Choke Adjustment (if equipped):** Some gasoline engines may have a choke adjustment, pull the choke lever out to choke the engine. Push the choke lever in for normal engine operations.
5. **Throttle Adjustment (if equipped):** Some engines may have a knob or a handle for the throttle adjustment. Typically you would pull the knob out, or turn the handle to increase the engine R.P.M.'s. To decrease you would push in the knob or turn the handle the opposite way.
6. **“Bandit” Lever Lock Cable Throttle System (if equipped):** The Bandit throttle system has (2) positions, HIGH and LOW. Engine R.P.M. is controlled by moving the lever from one position to the other.
7. **Push Button Or Electric Throttle System (if equipped):** Some engines may have a push button or electric throttle adjustment. Engine R.P.M. is controlled by pushing a button or switch to raise or lower the R.P.M.
8. **Alternator Warning Light:** This light will glow when the alternator is not charging, or when the ignition switch is turned on and the engine is not running.
9. **Oil Pressure Warning Light:** This light will glow when the oil pressure is to low, or when the ignition switch is turned on and the engine is not running.
10. **Engine Temperature Warning Light:** This light will glow when the engine, or engine coolant, is above normal operating temperature. If this occurs allow the engine temperature to cool down. If the engine is overheating because of a loss of coolant, or a broken fan belt, shut the engine off immediately.

NOTICE

Most engines have an automatic low oil pressure shut down device, but some engines do not for example the Lombardini 9LD. Expensive damage may occur if the engine oil level and condition is not checked daily. Follow all maintenance procedures specified by the engine manufacturer's manual. Check the fuel level daily, running out and repriming is time consuming. Do not over fill the tank, there must be expansion space in the top of the tank. Inspect hoses, fittings, lines, tanks, etc. for any oil, fuel, engine coolant, etc. leaks daily. Repair or replace any damaged or leaking components.

TYPICAL DIESEL ENGINES

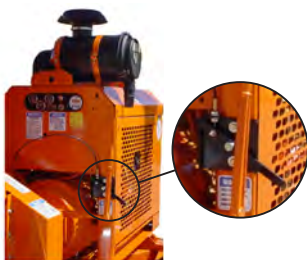

BANDIT THROTTLE SYSTEM

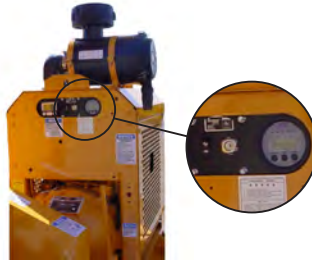

PUSH BUTTON OR ELECTRIC THROTTLE SYSTEM

TYPICAL GASOLINE ENGINE



MACHINE OPERATION

- Check all fluids before starting the machine.
- Make sure to go through the daily start-up and maintenance procedures before operating the machine.
- Cutter wheel must be disengaged before starting.
- Start engine at idle speed and allow for sufficient time for oil to circulate before proceeding.
- Test all controls for proper operation.
- Avoid transversing slopes.

DANGER

DO NOT OPERATE AROUND WATER, GAS, POWER OR PHONE LINES. IF IN DOUBT, CHECK BEFORE GRINDING.

DANGER

WEAR ALL PERSONAL PROTECTIVE EQUIPMENT PER ANSI, OSHA AND MANUALS.

DANGER

KEEP CLEAR OF CUTTING WHEEL, MOVING MACHINE PARTS AND GRINDER DEBRIS FIELD.

Position machine at stump with cutter wheel a slight distance away from stump.

Reduce engine RPM to idle.

If equipped, position the swing out in the operating position and lock the spring loaded pin. Also unpin the swing out chip curtain.

Raise cutter wheel clear of stump.

Engage the cutter wheel.

Increase engine RPM to full.

Test the controls for proper operation, speed, and unobstructed movement.

The cutter wheel swing speed should be adjusted to a rate that will allow cutter wheel to pass through stump smoothly. If jerking, bouncing or significant drops in engine speed occur, swing rate is too rapid and must be decreased.

Swing speed should be determined and adjusted with the controls in the full open position.

A swing speed control is located on the side of the control box of the machine to adjust this speed. Turning the dial clockwise will slow the swing action.

Travel speed should be adjusted to a rate that will allow cutter wheel to approach stump smoothly. If cutter wheel is approaching stump quickly, travel speed is too rapid and must be decreased.

Travel speed should be determined and adjusted with the controls in the full open position.

A travel speed control is located on the side of the control box of the machine to adjust this speed. Turning the dial clockwise will slow the travel speed, depending on the type of controls and when the machine was built.

Lower the spinning cutter wheel to the stump and make a few light passes at the stump to get a feel for the cutting action.

Gradually increase cutting action and work away at the stump by swinging cutter wheel left-to-right-to-left through stump in a sideways motion. Smooth, effortless cutting lengthens machine life, minimizes down time and is more profitable in the long run.

Continue cutting stump by adjusting cutting wheel progressively lower until stump is cut well below ground level.

Swing cutter wheel clear of stump and position machine closer to stump for next series of passes and continue cutting. If the machine is equipped with a tongue extension, reposition the cutter wheel with the tongue extension control.

Continue in this manner until stump has been removed.

Larger stumps may require repositioning machine to remove complete stump.

Raise cutter wheel clear of stump and return to center position.

Reduce engine speed to idle and disengage cutter wheel. **DO NOT TURN OFF MOTOR.** Engine should be allowed to cool slowly at idle for 3-5 minutes to avoid damage.

DO NOT ENGAGE OR DISENGAGE CUTTER WHEEL AT A HIGH ENGINE SPEED. Damage to machine will occur.

At low engine RPM, the cutter wheel swing speed control needs to be closed or slowed all the way down for the cutter head to swing. The direction the control knob needs to be turned will depend on the type of controls and when the machine was built.

Turn off engine.

Allow cutter wheel to come to a complete stop before inspecting.

CUTTING AREA

⚠ DANGER

For optimum performance, the stump should be cut with the portion of the cutter wheel shown below. **NEVER UNDERCUT THE STUMP.** Undercutting the stump may cause severe kickback, vibration and component damage. **NEVER CUT THE STUMP FROM THE TOP.** The cutter wheel will throw debris up and toward the operator, instead of down and under the machine.

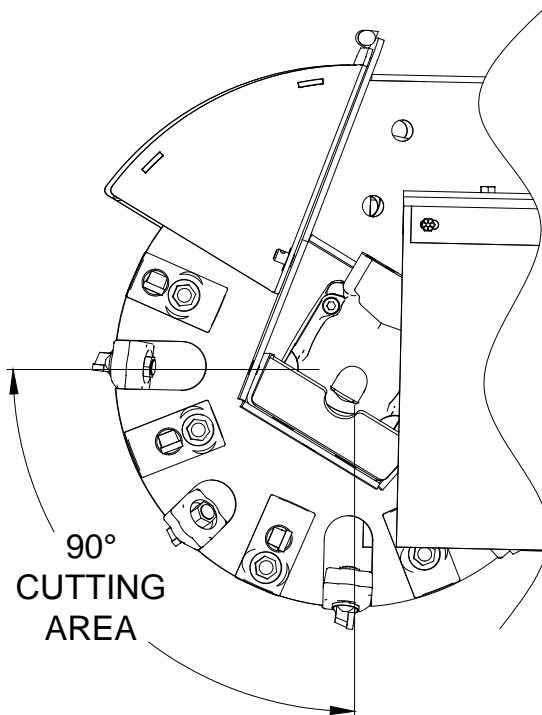

⚠ DANGER

**← FLYING OBJECTS
STAND CLEAR
OR YOU WILL BE
INJURED!**

MOVING A MACHINE WITHOUT POWER (MODEL 2550)

NOTICE

Use this procedure only when the machine will not start or run to help prevent damage to the hydraulic system. With the key in the “off” position and in your possession, follow the steps below:

1. Close the needle valve (see Figure 1) by turning the knob clockwise 3 to 4 full turns. It will be located near the side of the control cabinet.
2. Close the ball valve located between the control cabinet and the hydraulic tank, see Figure 2.
3. Pump the brake release 2 to 4 pumps. The brake release is located inside of the control cabinet. See Figure 3.
4. The machine is now in freewheel mode, although there will be drag from the drive wheel motor.
5. Reverse steps 2 and 1 after moving the machine.

FIGURE 1

Turn clockwise 3 to 4 full turns.



FIGURE 2



Ball Valve

FIGURE 3

Swing-Out Control Machine



Brake Release

Remote Control Machine



Brake Release

TRANSPORTATION PROCEDURES

WARNING

BEFORE TRANSPORTING THE MACHINE, INSPECT AND CONFIRM THE FOLLOWING STEPS:

1. The trailer has a cargo weight rating capacity for the weight of the stump grinder. The combined weight of the trailer and the stump grinder can not exceed the load capacity of the tires, axles, hitch coupler system or the GVWR (Gross Vehicle Weight Rating) of the trailer.
2. The towing vehicle is rated for and has the towing capabilities to haul the stump grinder package (includes the stump grinder and a trailer). The towing vehicle must be mechanically sound and capable of handling the towing job.
3. The hitch on the towing vehicle and the coupler on the trailer is a perfect match in size, type, and needed capacity.
4. Both the towing hitch and the coupler are in good mechanical and wear condition, that they are joined together securely, and the coupler/hitch is locked in place.
5. The safety chains have the correct capacity for the equipment being towed.
6. The safety chains are crossed under the coupler/hitch then securely attached to the towing vehicle. The safety chains are long enough to not restrict the turning movement, but short enough to not drag on the road.
7. The electrical plug-in on the towing vehicle and the trailer are wired for the same functions and they fit securely together. The plug-in wire is long enough to not restrict the turning movement, but short enough to not drag on the road. The trailer must have a lighting system and braking system to match and perform correctly off the towing vehicles system. You must meet the Federal and your States' Department of Transportation Code of Regulations concerning lights, brakes, and highway transit.
8. The break-away actuator (if equipped) that is installed on the trailer correctly works and is appropriately attached to the towing vehicle.
9. All lights and brakes on the trailer correctly functions when activated by the systems in the towing vehicle.
10. The tires have been checked for cuts or damaged rims, air pressure is correct, and the axle lug nuts have been checked for correct torque (refer to trailer manual).
11. When the stump grinder is on the trailer, the trailer has the right load capacity, the stump grinder is positioned on the trailer for the correct weight distribution (there should be about 15% of the total stump grinder package weight on the tongue or hitch), the stump grinder brakes are locked, the cutter wheel is resting on the trailer bed, and the stump grinder is securely bound down to the trailer bed per your States binding requirements.
12. Any loose debris, tools or parts have been cleared off or are put away.
13. Close and secure any of the following if equipped: tool box, battery box, engine cowl doors and side panels, radiator debris screens, inspection doors, cabinet doors, housing covers, tank caps and covers, vise, etc.
14. Make sure the load ramps are securely stored for transport.
15. Make sure the stump grinder's engine is not running, the ignition key is in your possession, and all controls are stored correctly and locked in place for transport.
16. The stump grinder package must be hauled level and the towing vehicle must be sized to handle hitch weight and towing weight. The towing vehicle or the combination of towing vehicle and towing package must have enough braking capacity to meet the Federal and your State Department of Transportation requirements.
17. The stump grinder package is now ready for transport. Make sure to obey all local regulation and laws regarding the transporting of this type of machine.
18. Do not drive too fast for road conditions or exceed speed regulations for equipment towing.

LOADING & UNLOADING

WARNING

BEFORE LOADING OR UNLOADING THE MACHINE, INSPECT AND CONFIRM THE FOLLOWING STEPS: When loading or unloading the self-propelled machine on the trailer, use care and caution. The maneuvering of the equipment must be slow, smooth, and intentional, not fast and jerky.

DANGER

Never load or unload the machine with the drive lock pin pulled out of the rim. Make sure the drive lock pin is in all the way.

1. Make sure the trailer and towing vehicle are parked on a flat surface. They must be stable on the surface with the brakes locked and/or the wheels chocked to avoid unwanted movement.
2. Position the loading ramps or loading gate securely between the trailer and the ground level. Have them located so that they are in line with the tires or tracks of the machine when it moves.
3. Remove and store the chains and binders used for transporting.
4. Confirm that there are not any obstacles on the trailer bed, around the trailer that may cause restricted movement of the machine or the operator.
5. The only person in the area should be the one that is operating the machine controls, and he/she should be very experienced with the controls on this machine.
6. If you are on streets, roads or public areas, position the warning cones etc, per your company's safety policy.
7. Follow all pre-startup instructions for the machine.
8. Once the engine is running at as low a speed as possible, carefully raise the cutter wheel slightly up off the ground or trailer bed. While loading or unloading the stump grinder, the cutter wheel should not be raised any higher than necessary to just clear whatever is under it. You need to keep the weight center of gravity as low as possible to avoid tipping the machine while it is moving.
9. The cutter wheel end of the stump grinder should always be positioned so that it is toward the rear of the trailer, not the tongue, during transport.
10. When the machine is positioned on the trailer bed, there should be about 15% of the total trailer package weight on the tongue or hitch.
11. Align the machine with the trailer bed, and the loading ramps. The only equipment movement should be slowly, straight on or straight off the trailer.
12. With the engine and the machine at as low of speed as possible, move the machine toward the ramp system. Make sure the alignment is correct throughout the travel, and carefully readjust the cutter wheel height so that it barely clears obstacles as it is going up or down the ramp system.
13. Properly secure the equipment and the area to avoid any possible accidents or dangers.
14. The trailer should be constructed with appropriate chain down positions for the specific sized stump grinder. You must have binders that will withstand the strain of the machine trying to move while it is being transported.
15. The loading ramps or loading gate of the trailer must be constructed to withstand the weight and forces involved in loading and unloading the machine.

MAINTENANCE SECTION

The Bandit is a very simple machine to maintain. If you will follow a regular scheduled preventative maintenance program, you should have years of trouble free operation.

⚠ DANGER

Before attempting any type of maintenance disengage clutch, turn off engine, wait for the cutter wheel to come to a complete stop, install the cutter wheel lock pin, place the cutter wheel on the ground, disconnect battery, and make sure the ignition key is in your possession.

⚠ DANGER

Do not let anyone operate or maintain this machine until they have thoroughly read this manual, reviewed the equipment decals, watched the equipment video, and has been properly trained. You can purchase additional Bandit manuals, decals and videos for a nominal fee.

NOTICE

Consult your engine manual for proper break-in procedures. Various engines require somewhat different procedures, but basically the engines need to operate at lower R.P.M.'s and loads for a specific time.

NOTICE

Failure to properly break-in your engine may result in poor bearing and piston ring surfaces.

NOTICE

The Bandit has only been run for a short time to test proper hydraulic pressures, possible leaks, etc. The fuel tank will be empty. Fuel is provided through a small auxiliary tank for testing. This immensely helps maintain safety in our manufacturing facility and while shipping.

NOTICE

Expensive damage to the Bandit will occur if proper preparation is not taken before welding on the machine. Be sure to disconnect both battery cables and the engine ECM (engine control module) before welding. Follow the specific Engine MFG. instructions for proper welding and grounding procedures, before attempting to weld on the machine. If welding on the machine, do not ground the welder through the machine bearings, ground near work to be performed.

DAILY START UP & MAINTENANCE

1. Check the safety decals and engine gauges:

Replace any missing or damaged decals and/or engine gauges.

2. Check all safety equipment:

Check for proper operation. Repair or replace as needed.

3. Check entire machine for loose bolts, nuts, parts, or components:

Check entire machine for any loose parts or components. Check for loose nuts or bolts. Torque, tighten, or replace any of the loose components. See page 35 for specific bolt torques.

4. Check all guards:

Check to make sure all guards are in place and installed correctly. Make sure they are secure.

5. Check the cutter wheel and pockets for wear:

Check for elongated bolt holes, secure welds, torqued bolts, excessive wear, and impact cracks. If a problem is found, contact the grinder manufacturer or an authorized Bandit dealer.

6. Check condition of cutter teeth, pockets, and hardware:

Sharpen or replace your cutter teeth to keep them sharp. Check the condition of your teeth, pockets, and hardware. Replace if necessary.

7. Check cutter wheel pocket bolts:

All cutter wheel pockets bolts must be factory approved. Bolts must be replaced after a maximum of 4-5 rotations/changes to ensure safe clamping ability.

See Torque Chart for proper torque.

DAILY START UP & MAINTENANCE (cont.)

8. Grease cutter wheel arm pivot bushings:

Grease cutter wheel arm pivot bushings with 1 to 2 shots of EP-2 Lithium type grease. Wipe off excess grease. **Excessive grease will attract dirt.**

9. Check hydraulic oil level:

The hydraulic oil reservoir tank level should always remain at 7/8 full. Remember to check DAILY to avoid excessive heat build up.

10. Check for any fluid leaks:

Inspect for any oil, fuel, hydraulic oil, or engine coolant leaks. Check all hoses, fittings, lines, and tanks. DO NOT use fingers or skin to check for hydraulic leaks. Repair or replace any damaged or leaking components.

11. Check hydraulic control valves:

Inspect all hydraulic control valves and ensure they operate smoothly and shift correctly.

12. Check the fuel level:

Check the fuel level, running out and repriming is time consuming. Do not over fill, and you must leave fuel expansion space in the top of the tank.

13. Check engine oil and coolant level:

Follow the engine manufacturer manual recommendations for fluid levels. You **MUST** follow specific ENGINE MFG. manual recommendations for radiator coolant, additives, lubrication, correct engine speed, ETC.

14. Check radiator, debris screen:

Thoroughly clean radiator fins at least once a day or more in excessive conditions. Make sure debris is not packed between fins. Use compressed air and/or pressurized water (soap may also be needed) to clean the radiator, depending on the level and type of debris. If pressurized water is used, be careful not to turn the debris hard and pack solid between the radiator fins. Make sure to clean the radiator in the correct direction depending on if the cooling fan is a sucker or a pusher; do not propel the debris into the radiator with compressed air or pressurized water. A partially plugged radiator will not allow the engine to cool properly. Keep the compressed air or pressurized water a safe distance from the radiator fins so they are not damaged. Visually inspect the radiator fins and make sure they are not bent or closed off, repair or replace as needed. Clean cooling fan, shroud on air cooled engines, and the debris screen (if so equipped). Improper service, maintenance, or neglect will cause overheating problems and/or engine failure. Refer to the engine manufacturer's manual.

15. Check oil cooler:

Thoroughly clean cooler fins at least once a day or more in excessive conditions. Make sure debris is not packed between fins. Use compressed air and/or pressurized water (soap may also be needed) to clean the oil cooler, depending on the level and type of debris. If pressurized water is used, be careful not to turn the debris hard and pack solid between the cooler fins. Make sure to clean the cooler in the correct direction; do not propel the debris into the cooler with compressed air or pressurized water. Keep the compressed air or pressurized water a safe distance from the cooler fins so they are not damaged. Visually inspect the cooler fins and make sure they are not bent or closed off, repair or replace as needed.

16. Check air cleaner or precleaner:

Clean or replace element following engine manual recommendations. Also, check and clean the vacuator valve.

17. Check tires (Model 2550):

Check tires for wear, weather checking and damage. Replace if damaged.

18. Inspect axle dust caps (Model 2550):

Inspect axle dust caps and replace if damaged or leaking.

19. Check tracks (Model 2550T):

Check track tension, should have approximately 1/4" (6 mm) of deflection with 10 lbs (4.5 kg) of force. Adjust as necessary. Also check tracks for wear, weather checking and damage. Replace if damaged.

20. Check around machine:

Check around the entire machine for tools, cans, saws, etc. All tools not in use should be stored in a tool box.

21. Review all safety procedures on decals, from manual, and from video.

22. Make sure all safety equipment is being worn:

Make sure you are wearing all of your safety equipment: hard hat, face shield, gloves, eye protection, ear protection, etc. per ANSI and OSHA standards.

23. Remember to check EVERYTHING on the checklist.

WEEKLY MAINTENANCE

1. Grease swing pivot assembly bushings:

Grease the top and bottom swing pivot assembly bushings with 1 to 2 shots of EP-2 Lithium type grease. Wipe off excess grease. **Excessive grease will attract dirt.**

2. Grease steering axle pivot bushings (Model 2550):

Grease steering axle pivot bushings with 1 to 2 shots of EP-2 Lithium type grease. Wipe off excess grease. **Excessive grease will attract dirt.**

3. Grease steering bushings (Model 2550):

Grease steering bushings with 1 to 2 shots of EP-2 Lithium type grease. Wipe off excess grease. **Excessive grease will attract dirt.**

4. Grease cylinder lug pin bushings:

Grease cylinder lug pin bushings with 1 to 2 shots of EP-2 Lithium type grease. Wipe off excess grease. **Excessive grease will attract dirt.**

5. Grease swing out pivot bushings:

Grease swing out pivot bushings with 1 to 2 shots of EP-2 Lithium type grease. Wipe off excess grease. **Excessive grease will attract dirt.**

6. Lubricate all steel friction areas::

Lubricate all steel friction areas including , but not limited to pivoting, hinged, sliding, rotating areas on the machine (i.e. cutter wheel guard, control box doors, etc.).

7. Check the cutter wheel hydraulic motor coupler:

Remove the cover plate over the cutter wheel hydraulic motor coupler and check the torque of the coupler bolts, see Torque Chart.

8. Check and retighten tank mount bolts:

Check and retighten the fuel tank and hydraulic tank mount bolts.

9. Check alternator and fan belts on engine (as applicable):

Adjust and maintain per the engine manufacturer's manual.

10. Check wheel lug nuts (Model 2550):

Keep lug nuts tight, retorque, replace if needed.

MONTHLY MAINTENANCE

1. Grease grading blade bushings (if equipped):

Grease steering axle pivot bushings with 1 to 2 shots of EP-2 Lithium type grease. Wipe off excess grease. **Excessive grease will attract dirt.**

2. Lubricate cutter wheel engagement lever cable:

Lubricate cutter wheel engagement lever cable and cable ends with a cable lube or SAE 10W/30 oil. Replace cutter wheel engagement lever cable if it doesn't operate smoothly.

3. Tire air pressure (Model 2550):

Fill each tire to rated capacity on tire.

4. Check hydraulic function pressures:

Check, reset and maintain all hydraulic function pressure settings to a maximum of the specified PSI (bar). This will give you the best performance from the hydraulic system.

3 MONTH MAINTENANCE

1. Hydraulic oil filter(s):

Must be replaced after FIRST 10 HOURS OF OPERATION, USE A 10 MICRON FILTER. After first change replace oil filter every 3 months or 400 hours.

YEARLY MAINTENANCE

1. Grease steering wheel hub bearings (Model 2550 with 2 Wheel Drive):

Inspect and clean the steering wheel hub bearings, cups, and seals. Replace seals if ever removed. Replace bearings and cups as needed. Grease the wheel bearings with an EP-2 Lithium type grease. Remove rubber plug and pump grease into E-Z Lube zerk until all of the old grease is pumped out of the dust cap. Wipe off excess grease. **Excessive grease will attract dirt.**

2. Fuel tank:

Drain and clean the fuel tank yearly.

2. Hydraulic oil:

Change hydraulic oil and flush the hydraulic reservoir tank.

4. Hydraulic suction screen(s):

Change hydraulic suction screen(s) yearly or every 2000 hours.

DAILY START UP & MAINTENANCE CHECK LIST

Each day before starting your machine these checks must be made:

	OK	Repaired
1. Check the safety decals and engine gauges, replace if damaged.	<input type="checkbox"/>	<input type="checkbox"/>
2. Check, maintain, and service all safety equipment for proper operation.	<input type="checkbox"/>	<input type="checkbox"/>
3. Check entire machine for loose nuts, bolts, and components.	<input type="checkbox"/>	<input type="checkbox"/>
4. Check all guards to make sure they are tight and securely in place.	<input type="checkbox"/>	<input type="checkbox"/>
5. Check the condition of the cutter wheel and teeth pockets.	<input type="checkbox"/>	<input type="checkbox"/>
6. Check the condition of the cutter teeth, pockets, and hardware.	<input type="checkbox"/>	<input type="checkbox"/>
7. Properly torque cutter wheel pocket bolts.	<input type="checkbox"/>	<input type="checkbox"/>
8. Grease cutter wheel arm pivot bushings with 1 to 2 shots.	<input type="checkbox"/>	<input type="checkbox"/>
9. Check and always maintain hydraulic level at 7/8 full.	<input type="checkbox"/>	<input type="checkbox"/>
10. Check all hoses, fittings, lines, and tanks for damage and fluid leaks.	<input type="checkbox"/>	<input type="checkbox"/>
11. Check hydraulic control valves and ensure they operate and shift correctly.	<input type="checkbox"/>	<input type="checkbox"/>
12. Check fuel level. (Running out and repriming is time consuming).	<input type="checkbox"/>	<input type="checkbox"/>
13. Check engine oil, coolant levels, and correct engine speed. Follow ENGINE MANUFACTURER'S manual specs.	<input type="checkbox"/>	<input type="checkbox"/>
14. Check radiator and debris screen. Clean as necessary. Clean cooling fan and shroud on air cooled engines.	<input type="checkbox"/>	<input type="checkbox"/>
15. Check oil cooler. Clean as necessary.	<input type="checkbox"/>	<input type="checkbox"/>
16. Check air cleaner, precleaner, and vacuator valve. Clean as necessary.	<input type="checkbox"/>	<input type="checkbox"/>
17. Check condition of the tires (Model 2550).	<input type="checkbox"/>	<input type="checkbox"/>
18. Inspect and replace any axle dust caps that are damaged or leaking (Model 2550).	<input type="checkbox"/>	<input type="checkbox"/>
19. Check track tension and condition of the tracks (Model 2550T).	<input type="checkbox"/>	<input type="checkbox"/>
20. Check around the entire machine for any foreign objects, tools, cans, saws, etc.	<input type="checkbox"/>	<input type="checkbox"/>
21. Review all safety procedures on decals, from manual, and from video.	<input type="checkbox"/>	<input type="checkbox"/>
22. Wear all applicable safety equipment: hard hat, face shield, gloves, eye protection, ear protection, etc.	<input type="checkbox"/>	<input type="checkbox"/>
23. Remember to check EVERYTHING on the checklist.	<input type="checkbox"/>	<input type="checkbox"/>

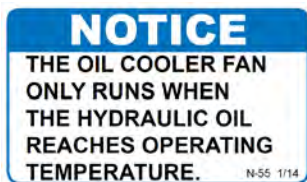

NOTICE

To link the transmitter and the machine:

1. Switch the transmitter power on
2. Switch the TETHER / REMOTE switch on the machine to the REMOTE position
3. Turn the ignition key to the ON position
4. When the machine link light turns on, start engine.



WEEKLY CHECK LIST

	OK	Repaired
1. Grease the top and bottom pivot assembly bushings with 1 to 2 shots.	<input type="checkbox"/>	<input type="checkbox"/>
2. Grease steering axle pivot bushings with 1 to 2 shots. (Model 2550)	<input type="checkbox"/>	<input type="checkbox"/>
3. Grease steering bushings with 1 to 2 shots. (Model 2550)	<input type="checkbox"/>	<input type="checkbox"/>
4. Grease cylinder lug pin bushings with 1 to 2 shots.	<input type="checkbox"/>	<input type="checkbox"/>
5. Grease swing out pivot bushings with 1 to 2 shots.	<input type="checkbox"/>	<input type="checkbox"/>
6. Lubricate steel friction areas: pivoting, hinged, sliding, & rotating areas (i.e. cutter wheel guard, control box doors, etc.)	<input type="checkbox"/>	<input type="checkbox"/>
7. Check the torque on the cutter wheel hydraulic motor coupler bolts 13 ft-lbs (18 Nm).	<input type="checkbox"/>	<input type="checkbox"/>
8. Check and retighten fuel tank and hydraulic tank mount bolts.	<input type="checkbox"/>	<input type="checkbox"/>
9. Check alternator and fan belts on engine, adjust, or replace.	<input type="checkbox"/>	<input type="checkbox"/>
10. Check and retighten wheel lug nuts. (Model 2550)	<input type="checkbox"/>	<input type="checkbox"/>

MONTHLY CHECK LIST

	OK	Repaired
1. Grease grading blade pivot bushings with 1 to 2 shots.	<input type="checkbox"/>	<input type="checkbox"/>
2. Lubricate cutter wheel engagement lever cable.	<input type="checkbox"/>	<input type="checkbox"/>
3. Check and fill tires to rated pressure. (Model 2550)	<input type="checkbox"/>	<input type="checkbox"/>
4. Check hydraulic function pressures. Set to specified PSI (bar).	<input type="checkbox"/>	<input type="checkbox"/>

3 MONTH CHECK LIST

	OK	Repaired
1. Replace hydraulic filter(s) after first 10 hours then quarterly or every 400 hours.	<input type="checkbox"/>	<input type="checkbox"/>

YEARLY CHECK LIST

	OK	Repaired
1. Inspect and clean steering wheel hub bearings, cups, and seals. Grease steering wheel hub bearings. Replace seals if ever removed. (Model 2550 with 2 Wheel Drive)	<input type="checkbox"/>	<input type="checkbox"/>
2. Drain and clean the fuel tank.	<input type="checkbox"/>	<input type="checkbox"/>
3. Change hydraulic oil and flush the hydraulic tank.	<input type="checkbox"/>	<input type="checkbox"/>
4. Replace hydraulic suction screen(s) annually or every 2000 hours.	<input type="checkbox"/>	<input type="checkbox"/>

BOLT TORQUE CHART

(THESE TORQUES ARE BASED ON DRY, CLEAN THREADS)

DESCRIPTION	BOLT SIZE	TORQUE (FT.-LBS.)	TORQUE(Nm)
Cutter Wheel Revolution Lead Tooth Nut	5/8"-18 NF	200	271
Cutter Wheel Revolution Side Tooth Nut	5/8"-18 NF	125	169
Cutter Wheel Green Tooth Pocket Bolts	5/8"-18 NF	125 - 150	169 - 203
Cutter Wheel Green Tooth Nut		31 - 43	42 - 58
Cutter Wheel Tomahawk Tooth	5/8"-18 NF	125 - 150	169 - 203
Cutter Wheel Coupler		13	18
Engine Hold Downs	1/2"-13 NC	95	129
Lug Nuts	1/2"-20 NF	90 - 120	122 - 163

Before tightening bolts be sure you have the correct size bolt for the correct amount of torque.
Use only factory approved knives and hardware.

PAINT CARE

To help keep up the appearance of your Bandit equipment and reduce the possibility of surface rust follow these steps:

1. The machine should be washed on a regular basis with a non-abrasive mild detergent and then rinsed thoroughly. Do not pressure wash sensitive areas like: decals, gauges, electronic devices, autofeed control, etc.
2. If a stone chip, paint scratch, or paint crack occurs - it should be repaired immediately. Simply sand the edges of the damaged paint area, mask off the surrounding area, and apply primer and paint to the dry, clean, and warm area. This will keep the damaged area from spreading or getting worse.
3. If you are unable to sand and mask the area, there are containers of primer and paint available. A small brush can be used to touch up the area.
4. Also, primer and most colors of paint are available in aerosol spray cans to simply spray over the effected area after it is cleaned, dry, and warmed. This method is not as reliable as the process in step #2.

It is also reported that some equipment owners polish their machine at least yearly, and keep good mud flaps on their towing trucks.

WINDOW WASHING INSTRUCTIONS

DO NOT use any glass cleaner on windows. Follow these steps to clean the windows:

1. Rinse with water to remove abrasive dirt.
2. Wash with soap or mild detergent, using a soft cloth sponge.
DO NOT SCRUB
3. Rinse once more, then dry with a soft cloth or chamois.
4. To remove grease, wet paint or decals: rub gently with a cloth wetted thoroughly in VM&P Natha or Isopropyl Alcohol. Wash and rinse.

DO NOT USE RAZOR BLADES, SCRAPPERS, SQUEEGEES, ETC.

LUBRICATION CHART

#	DESCRIPTION	CHECK			PROCEDURE
		DAY	WEEK	MONTH	
1	Cutter Wheel Arm Pivot Bushings	X			1 to 2 shots of grease - wipe off excess
2	Swing Pivot Ass'y Bushings		X		1 to 2 shots of grease - wipe off excess
3	Steering Axle Pivot Bushings-2550		X		1 to 2 shots of grease - wipe off excess
4	Steering Bushings-2550		X		1 to 2 shots of grease - wipe off excess
5	Cylinder Lug Pin Bushings		X		1 to 2 shots of grease - wipe off excess
6	Swing Out Pivot Bushings		X		1 to 2 shots of grease - wipe off excess
7	Steel Friction Areas: pivoting, hinged, sliding, rolling		X		Lubricate (i.e. cutter wheel guard, control box doors, etc)
8	Grading Blade Pivot Bushings			X	1 to 2 shots of grease - wipe off excess
9	Cutter Wheel Engagement Cable			X	Lubricate cable ends with SAE 10W/30
10	Wheel Hub Bearings-2550			Yearly	Grease until old grease is pumped out



A right angle grease fitting may need to be used to grease some of the lubrication points. This type of grease fitting can be obtained from most local automotive parts stores.

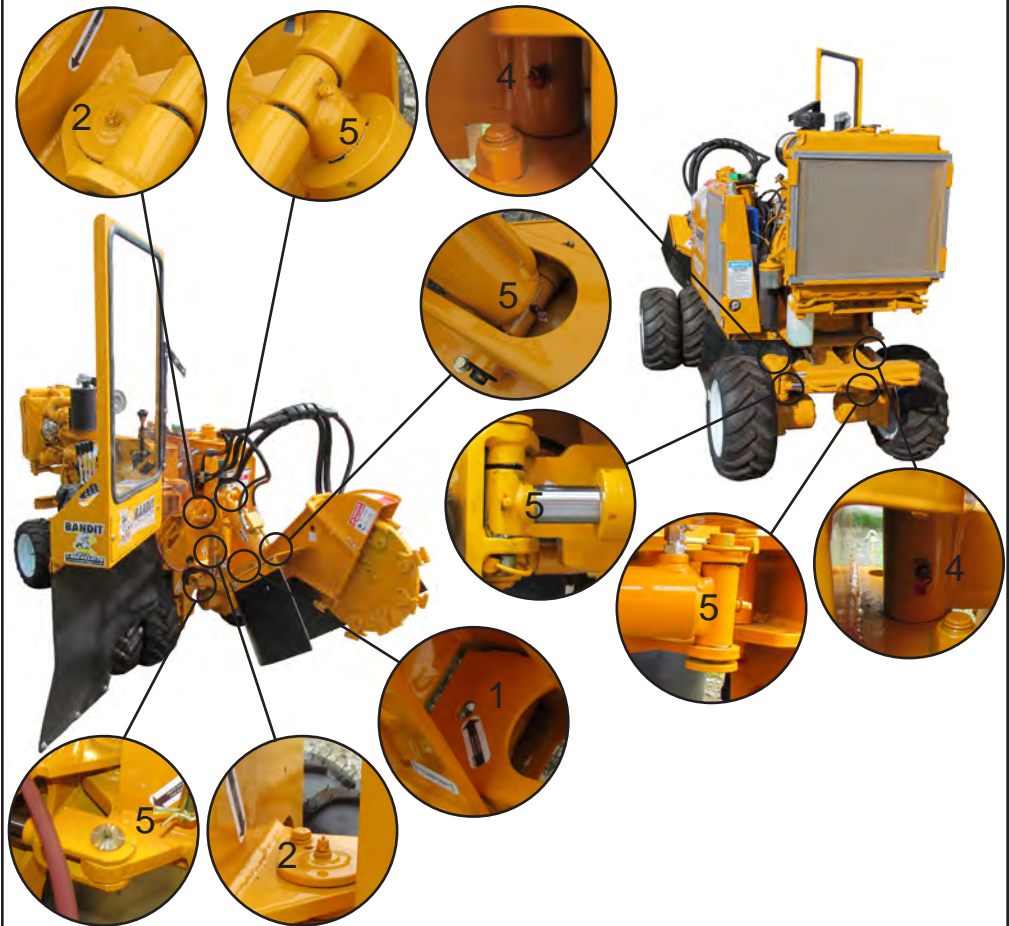

NOTICE Use as a reference only, locations may vary depending on options or component manufacturer. Lubrication point instructions are described on the machine, in the Lubrication & Coolant Section and Maintenance Section of this manual, or component manufacturer's manual.

LUBRICATION CHART



NOTICE Use as a reference only, locations may vary depending on options or component manufacturer. Lubrication point instructions are described on the machine, in the Lubrication & Coolant Section and Maintenance Section of this manual, or component manufacturer's manual.

CUTTER WHEEL MOTOR COUPLER

DANGER

Before attempting any type of maintenance disengage clutch, turn off engine, wait for the cutter wheel to come to a complete stop, install the cutter wheel lock pin, place the cutter wheel on the ground, disconnect battery, and make sure the ignition key is in your possession.

WEEKLY MAINTENANCE

1. Remove the coupler cover plate.
2. Check to make sure the coupler socket head cap screws are torqued to 13 ft-lbs (18 Nm).

DISASSEMBLY

1. Set the cutter wheel just above the ground and then follow all shut-down procedures prior to maintenance.
2. Unpin the cutter wheel guard and flip it up.
3. Remove the coupler cover plate.
4. Remove all the coupler screws..
5. Insert the coupler screws into the four (4) removal holes.
6. Tighten the screws to 7 ft-lbs (9 Nm) in a cross pattern.
7. Tighten the screws to 13 ft-lbs (18 Nm) in a cross pattern.
8. The coupler should come loose for removal.
9. Loosen the cutter wheel motor mount bolts.
10. Remove the cutter wheel motor from the mount bolts and the cutter wheel.
11. Remove the cutter wheel from the machine.
12. Firmly push the cutter wheel coupler from the hub. Do NOT pound it out, this will ruin the coupler.

INSTALLATION

1. Clean the hub bore and the motor shaft.
2. Do NOT use any oil, grease, or any other lubricant on the coupler, hub bore, or motor shaft.
3. Remove all the cutter wheel coupler screws, apply anti-seize on them, and install them back into the cutter wheel coupler.
4. Push the coupler into the hub of the cutter wheel by hand. Do NOT pound the coupler into the hub, this will make the coupler expand and ruin the coupler.
5. Install the cutter wheel motor bolts into the cutter wheel arm.
6. Install the cutter wheel motor onto the bolts as the cutter wheel is installed onto the cutter wheel motor shaft.
7. FOLLOW THE FOLLOWING STEPS CAREFULLY. IF THE STEPS ARE NOT FOLLOWED, THE CUTTER WHEEL COUPLER WILL NOT WORK PROPERLY, POSSIBLY CAUSING DAMAGE TO THE MACHINE.
8. Tighten the coupler socket head cap screws to 7 ft-lbs (9 Nm) in a **crossed pattern**.
9. Tighten the coupler socket head cap screws to 13 ft-lbs (18 Nm) in a **crossed pattern**.
10. Tighten the coupler socket head cap screws to 13 ft-lbs (18 Nm) in a **continuous sequence pattern**.
11. Install the coupler cover plate.

CUTTER WHEEL MOTOR COUPLER



Stub Shaft

Stub Shaft Brace

Cutter Wheel Hub

Coupler Removal Hole

Cutter Wheel



Cutter Wheel Motor Coupler

Cutter Wheel Motor Shaft

TROUBLE SHOOTING

PROBLEM	POSSIBLE CAUSE	SOLUTION
Engine will not start. (See Engine Mfg. manual for further information.)	<ol style="list-style-type: none"> 1. Loose ground cable. 2. Loose hot cable. 3. Dead battery. 4. Cutter wheel was engaged before the machine engine was started. 5. Batteries in remote are dead. 6. Kill switch on remote is activated. 	<ol style="list-style-type: none"> 1. Clean and tighten. 2. Clean and tighten. 3. Recharge or replace. 4. Make sure the ignition switch is off, disengage cutter wheel, and then restart the machine. 5. Replace. 6. Switch to run position.
Cutter wheel vibration.	<ol style="list-style-type: none"> 1. Tooth missing. 2. Pocket out of balance. 3. Improper tooth arrangement. 4. Loose hydrostatic motor bolts. 5. Bad hydrostatic motor. 	<ol style="list-style-type: none"> 1. Replace missing teeth. 2. Always replace pockets in pairs across from each other. 3. Install correctly with like pairs of teeth directly across from each other. 4. Tighten and retorque. 5. Replace.
Cutter wheel throwing teeth.	<ol style="list-style-type: none"> 1. Bad pocket. 2. Dirt in pocket. 	<ol style="list-style-type: none"> 1. Replace pocket. 2. Clean pocket and replace missing teeth.
Cutter wheel breaking teeth.	<ol style="list-style-type: none"> 1. Operator hitting rocks. 	<ol style="list-style-type: none"> 1. Avoid rocks, stones, etc.
Cutter wheel stops turning.	<ol style="list-style-type: none"> 1. Bad hydrostatic motor. 2. Bad hydrostatic pump. 3. Engagement cable loose or broke. 4. Low hydraulic pressure. 5. Debris wedged around cutter wheel. 	<ol style="list-style-type: none"> 1. Replace. 2. Replace. 3. Adjust or replace. 4. Reset pressure. 5. Clean out debris.
Bearing will not take grease.	<ol style="list-style-type: none"> 1. Grease fitting clogged. 	<ol style="list-style-type: none"> 1. Replace.
Machine will not respond to remote.	<ol style="list-style-type: none"> 1. Weak or dead batteries. 2. Remote not turned on before starting the machine engine. 3. Machine is out of range of the remote. 4. Broken or damaged antenna. 5. Remote power switch is turned off. 	<ol style="list-style-type: none"> 1. Replace. 2. Turn off engine, turn remote power on, and then restart the engine. 3. Move closed and make sure there are no obstructions between operator and machine. 4. Replace. 5. Shut down and restart the machine.

HYDRAULIC SECTION

WARNING

It is very important after you have operated a new machine for approximately an hour to shut down the machine and recheck all hydraulic fittings. Retighten as needed.

DO NOT GO NEAR HYDRAULIC LEAKS! High pressure oil easily punctures skin causing serious injury, gangrene, or death. Avoid burns from fluid. Hot fluid under pressure can cause severe burns. **DO NOT** use fingers or skin to check for leaks. Lower load or relieve hydraulic pressure before loosening fittings. Relieve all pressure in the system before disconnecting the lines, hoses, or performing other work. Use a piece of cardboard to find leaks. Never use your bare hands. Allow system to cool down to ambient temperature before opening any coolant or hydraulic oil system.

In cold weather situations let your hydraulic system idle for approximately 15 minutes to allow the system to warm up to operating temperature.

WARNING

DO NOT operate this machine unless all hydraulic control devices operate properly. They must function, shift and position smoothly and accurately at all times. Faulty controls can cause personal injury!

HYDRAULIC FLUID REQUIREMENTS

This machine is equipped with “Petro-Canada Hydrex XV” hydraulic fluid. It is recommended to replace with the same. “Petro-Canada Hydrex XV” is an all season hydraulic fluid. This is a premium performance, long life anti-wear, hydraulic fluid, designed for all season use in heavy duty hydraulic systems. “Petro-Canada Hydrex XV” allows year round use under wide extremes of temperature. It allows the hydraulic system to start at temperatures as low as -40°C/-40°F, under no load conditions and it improves lubrication of hydraulic components at high operating temperatures. It will also help protect against hydraulic failures during the wide temperature swings of spring and fall. To find the closest “Petro-Canada Hydrex XV” dealer call 1-888-284-4572.

Multi Viscosity motor oils are not recommended to mix with “Petro-Canada Hydrex XV” hydraulic oil. AW oils may mix with “Petro-Canada Hydrex XV” hydraulic oil. The following are specifications and authorizations of compatible oils. Only a high quality anti-wear (AW) hydraulic oil containing foam, corrosion, rust and oxidation inhibitors should be used. This viscosity grade depends on the oil temperature in service, based on the climate and operating conditions.

	Hydrex XV	ISO 22, AW	ISO 32, AW	ISO 46, AW	ISO 68, AW	ISO 100, AW
Viscosity Index	>235	>95	>95	>95	>95	>95
Flash Point	>240°C /464°F	>200°C /395°F	>210°C /410°F	>220°C /430°F	>220°C /430°F	>240°C /464°F
Oxidations Stability (ASTM D0943)	>9,000 Hours	>3,000 Hours	>3,000 Hours	>3,000 Hours	>3,000 Hours	>3,000 Hours
Cold Start-up, No Load, Max	-40°C/-40°F	-34°C/-29°F	-26°C/-14°F	-19°C/-3°F	-9°C/16°F	-4°C/24°F

HYDRAULIC SECTION

Alternate hydraulic oils are available, but they do not equal the performance or longevity of the “Hydrex XV” oil. Consult the following information supplied by the oil distributor.

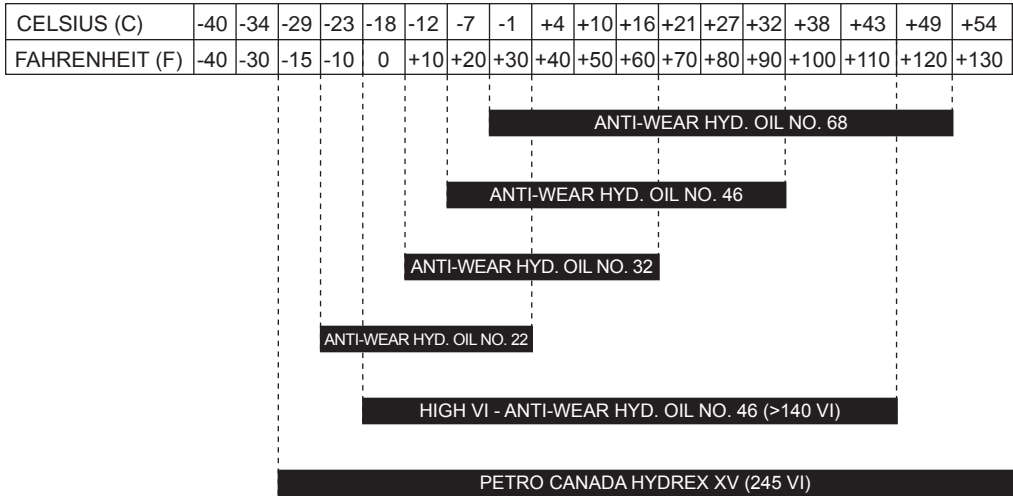

NOTICE

The above chart is a suggested guide for viscosity of hydraulic fluids at start up ambient temperature. The load, demand, and cleanliness of the equipment will affect actual oil temperatures which can increase dramatically above ambient air temperatures during operation. The actual viscosity needed is based on oil temperature during operation and not air temperature. Compare your fluid specifications with the specifications below to verify compliance.

When choosing a hydraulic fluid - these maximum and minimum specifications must be met:

Minimum Viscosity during operation = 12 cSt
 Maximum No-Load Viscosity at start-up = 2000 cSt

Hydraulic fluids vary in their resistance to oxidation at elevated temperatures, their ability to protect against metal-to-metal contact under increasing temperature, and their ability to separate water from the fluid. Viscosity is temperature dependant. Fluids with high viscosity-index (VI) will thin out slower at higher temperature and thicken slower at colder temperatures allowing a wider operating range. Choose a fluid that has test results in these areas for best results.

Based on the varying temperatures of the area where Bandit equipment is used, and the high demand and loads placed on this equipment, Bandit has filled each hydraulic system with Petro-Canada’s Hydrex XV All Season Hydraulic Fluid for maximum protection and performance.

Contact Petro Canada at (888) 284-4572 to find a dealer near you.

NOTICE

Some equipment and components such as a fluid engagement clutch (PTO) have their own lubrication requirements. Consult their manufactures manual for that information.

HYDRAULIC SECTION

TYPICAL HYDRAULIC RELIEF PRESSURE SETTINGS TYPICAL HYDRAULIC FLOWS AND RPM SETTINGS (Approximate, For Reference Only, Engine At Full RPM)

Equipment Model	2550	2550T
Cutter Wheel Pump GPM (LPM)	38.9 (147) - Gas Engine 32.4 (122) - Diesel Engine	38.9 (147) - Gas Engine 32.4 (122) - Diesel Engine
Auxiliary Pump GPM (LPM)	4.7 (18) - Gas Engine 3.9 (15) - Diesel Engine 7.6 (28) - Gas Engine & Optl. 4WD 6.3 (23) - Diesel Engine & Optl. 4WD	4.7 (18) - Gas Engine 3.9 (15) - Diesel Engine
Function Main Relief PSI (bar)	2750 (189)	2750 (189)
Cutter Wheel Down Relief PSI (bar) - Remote Machine Only	2750 (189)	1800 (124)
Swing PSI (bar)	2750 (241)	1600 (110)
Steer PSI (bar)	2750 (241)	
Drive PSI (bar)		3000 (206)
Cutter Wheel PSI (bar)	4500 (310) - Diesel Engine 3500 (241) - Gasoline Engine	4500 (310) - Diesel Engine 3500 (241) - Gasoline Engine
Charge PSI (bar)	180 - 200 (12 - 14)	180 - 200 (12 - 14)
Cutter Wheel RPM	1860 - Diesel Engine 2150 - Gasoline Engine	1860 - Diesel Engine 2150 - Gasoline Engine

NOTICE

DO NOT UNDER ANY CIRCUMSTANCES OVER-SET THESE RELIEF PRESSURES, BECAUSE IT WILL CAUSE DAMAGE TO COMPONENT PARTS AS WELL AS HYDRAULIC PARTS.

NOTICE

These typical hydraulic flows and relief pressure settings are with the engine at full RPM. All settings are subject to change!

CAUTION

After the initial start-up of the machine and after any replacement of hydraulic components, that fittings and hoses should be re-checked for leaks and clearances.

HYDRAULIC SECTION

THE BANDIT HYDRAULIC SYSTEM

The Bandit is equipped with a very efficient, simple hydraulic system. Each component is capable of withstanding a specified PSI (bar) and still operate for a very long time.

If the simple rules mentioned below are followed, the hydraulic components will last for years:

- After you have operated a new machine for approximately an hour shut down the machine and recheck all hydraulic fittings for tightness and leaks.
- Avoid hydraulic pump cavitation. Low oil levels or cold start-ups will cause the hydraulic pump to cavitate. Cavitation will ruin the pump and possibly the entire hydraulic system. Cavitation only has to happen once. This will start the pump on its way to ruin. Allow hydraulic system to turn slowly for several minutes in cold weather in order for hydraulic system to warm up. Cavitation is not covered under warranty.
- Do not increase the relief valve settings beyond specified PSI (bar). This will cause damage to hydraulic components. Do not set any other hydraulic component past it's specified pressure or this will cause damage to the hydraulic components.
- Keep hydraulic oil clean. Dirty oil will cause excessive wear and loss of hydraulic power.
- Replace the hydraulic oil filter(s) after first 10 hours and with each 400 hours of operation or 3 months.

- Replace hydraulic oil & suction screen(s) at least once yearly. This is also a very good time to flush and clean the tank. Replace hydraulic oil immediately if it is contaminated or looks "milky". See pages 41 - 42 for hydraulic oil requirements.
- If the Bandit's hydraulic system is kept clean and the hydraulic pressures are not increased beyond the specified PSI (bar), the maximum use and life should be received from the Bandit grinder hydraulic system.
- If a problem is encountered, it will more than likely be located in the relief valve or something as simple as belts or clutch slipping, check these first.
- Do not close the hydraulic shut-off valve for more than 3 to 4 seconds. Hydraulic shut-off valve handle must be completely turned on (in line with hose) at all times unless checking hydraulic pressure. Pressure gauge should be safely stored and installed only when checking pressure. Follow above instructions or this will cause unwarranted damage to the hydraulic components.
- Never close the ball valves on the hydraulic tank suction ports (if equipped) while the machine is running, this will ruin the hydraulic pump and components.
- Some component manufacturers require different specific hydraulic lubrication, such as gear boxes, undercarriage drives, etc. Refer to their manuals and maintenance section of this manual.



CAUTION

After the initial start-up of the machine and after any replacement of hydraulic components, that fittings and hoses should be re-checked for leaks and clearances.

HYDRAULIC SECTION

WARNING

It is very important after you have operated a new machine for approximately an hour to shut down the machine and recheck all hydraulic fittings. Retighten as needed.

DO NOT GO NEAR HYDRAULIC LEAKS! High pressure oil easily punctures skin causing serious injury, gangrene, or death. Avoid burns from fluid. Hot fluid under pressure can cause severe burns. **DO NOT** use fingers or skin to check for leaks. Lower load or relieve hydraulic pressure before loosening fittings. Relieve all pressure in the system before disconnecting the lines, hoses, or performing other work. Use a piece of cardboard to find leaks. Never use your bare hands. Allow system to cool down to ambient temperature before opening any coolant or hydraulic oil system.

In cold weather situations let your hydraulic system idle for approximately 15 minutes to allow the system to warm up to operating temperature.

WARNING

DO NOT operate this machine unless all hydraulic control devices operate properly. They must function, shift and position smoothly and accurately at all times. Faulty controls can cause personal injury!

NOTICE

Some equipment and components such as fluid engagement clutch's (PTO's) have their own lubrication requirements. Consult their manufactures manual for that information.

DANGER

Before attempting any type of maintenance disengage clutch, turn off engine, wait for the cutter wheel to come to a complete stop, install the cutter wheel lock pin, place the cutter wheel on the ground, disconnect battery, and make sure the ignition key is in your possession.

NOTICE

DO NOT UNDER ANY CIRCUMSTANCES OVER-SET THESE RELIEF PRESSURES, BECAUSE IT WILL CAUSE DAMAGE TO COMPONENT PARTS AS WELL AS HYDRAULIC PARTS.

NOTICE

These typical hydraulic flows and relief pressure settings are with the engine at full RPM. All settings are subject to change!

CAUTION

After the initial start-up of the machine and after any replacement of hydraulic components, that fittings and hoses should be re-checked for leaks and clearances.

NOTICE

When returning hydraulic components for warranty make sure to box up all warranted parts to avoid additional damage while shipping. **Do not disassemble any hydraulic components which are to be warranted.** Anything which has been disassembled or tampered with will not be warranted. Items being returned must be clean. All hydraulic components must have all hosing ports plugged. Failure to plug ports will allow debris to enter components which will void warranty.

NOTICE

In cold weather situations, let the hydraulic system idle for approximately 15 minutes to allow the system to warm up to operating temperature. Running cold oil through the hydrostatic motor can raise the case drain pressures and damage the shaft seals.

CHECKING HYDRAULIC PRESSURE

The relief valve is typically located internally in the valve bank. Do not adjust the relief valves above the specified psi (bar). The relief valve system is a simple spring tension design but small pieces of debris can stick the valve partially open which weakens the hydraulic power. The relief as well as hydraulic oil, and suction screen must be kept clean.

WARNING

Before attempting any hydraulic pressure settings, make sure engine is shut off, engine key removed and in your possession, hydraulic oil is clean, hydraulic tank is 7/8 full, and the machine has been pre-run to warm the hydraulic oil. To correctly check relief valve pressure, gauge MUST be installed correctly.

CHECKING HYDRAULIC FUNCTION PRESSURE

1. Make sure all the controls are in the off position.
2. Install pressure gauge into the test port. See Figure 1 if the machine has swing out controls and see Figure 2 or Figure 3 if the machine has remote controls.
3. Start engine and adjust engine to full throttle.
4. If the machine has swing-out controls, Pull the cutter wheel lift control lever (if the machine has swing out controls) or remote switch (if the machine has remote controls) towards the operator so that the cylinder bottoms out and then read the pressure gauge.
5. Adjust relief if necessary. Turn the relief clockwise to increase pressure and counter-clockwise to decrease the pressure.
6. If the machine has remote controls, also check the cutter wheel lift down pressure and adjust the relief if necessary.

CHECKING CUTTER WHEEL PRESSURE

1. Make sure all the controls are in the off position.
2. Install the cutter wheel lock pin
3. Install pressure gauge into the test port, see Figure 4.
4. Start engine.
5. Place the cutter wheel on the ground.
6. Engage the cutter wheel by pushing the button on top of the control lever and pulling it towards the operator.
7. Adjust engine to full throttle.
8. Adjust relief if necessary. Turn the relief clockwise to increase pressure and counter-clockwise to decrease the pressure.

CHECKING PUMP CHARGE PRESSURE

1. Make sure all the controls are in the off position.
2. Install pressure gauge into the test port, see Figure 5.
3. Start engine.
4. Adjust engine to full throttle.
5. The pressure reading is used to trouble shoot the machine.

CHECKING HYDRAULIC FUNCTION PRESSURE

FIGURE 1 Swing Out Controls

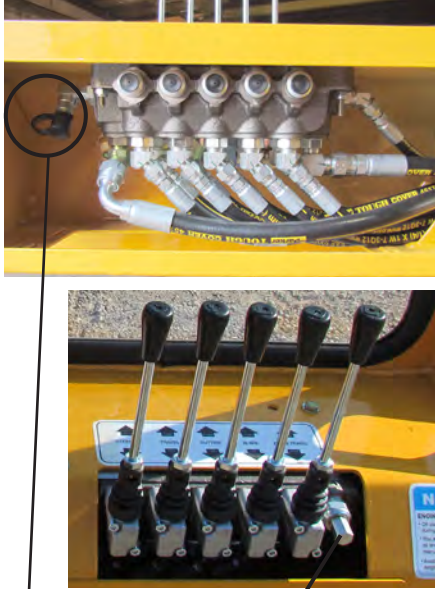

Test Port

Main Relief

FIGURE 2 Model 2550 Remote Control

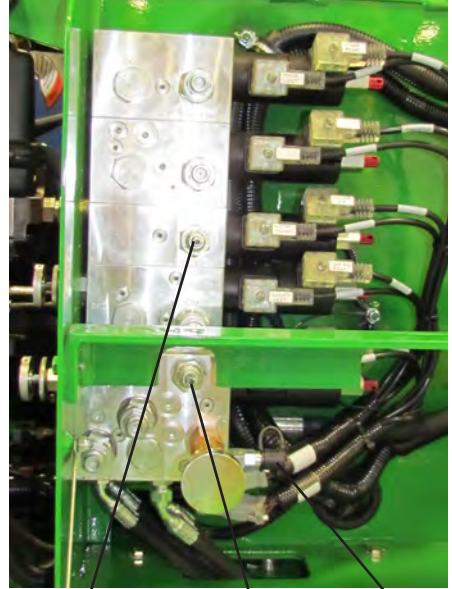

Cutter Wheel
Lift Down
Relief

Main Relief

Test Port

FIGURE 3 Model 2550T Remote Control

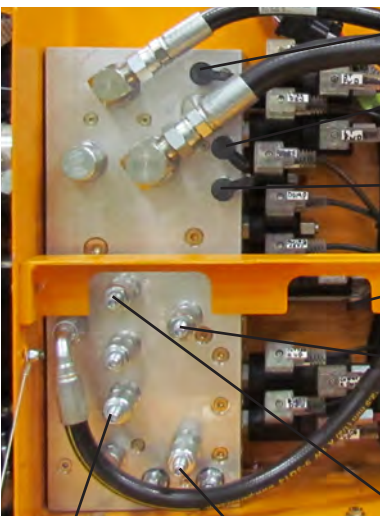

Test Port
Right Track

Test Port
Left Track

Test Port
Main

Test Port
Functions

Auxiliary
Pump Relief

Swing
Relief

Cutter Wheel
Lift Down
Relief

Grading
Blade Relief

FIGURE 4

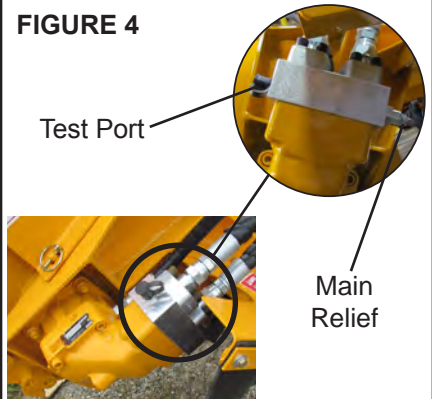

Test Port

Main Relief

FIGURE 5



Test Port

MODEL 2550 - SWING OUT CONTROLS

SPECIFIC SCHEMATIC FUNCTION MAY VARY DEPENDING ON OPTIONS OR COMPONENT MANUFACTURE.

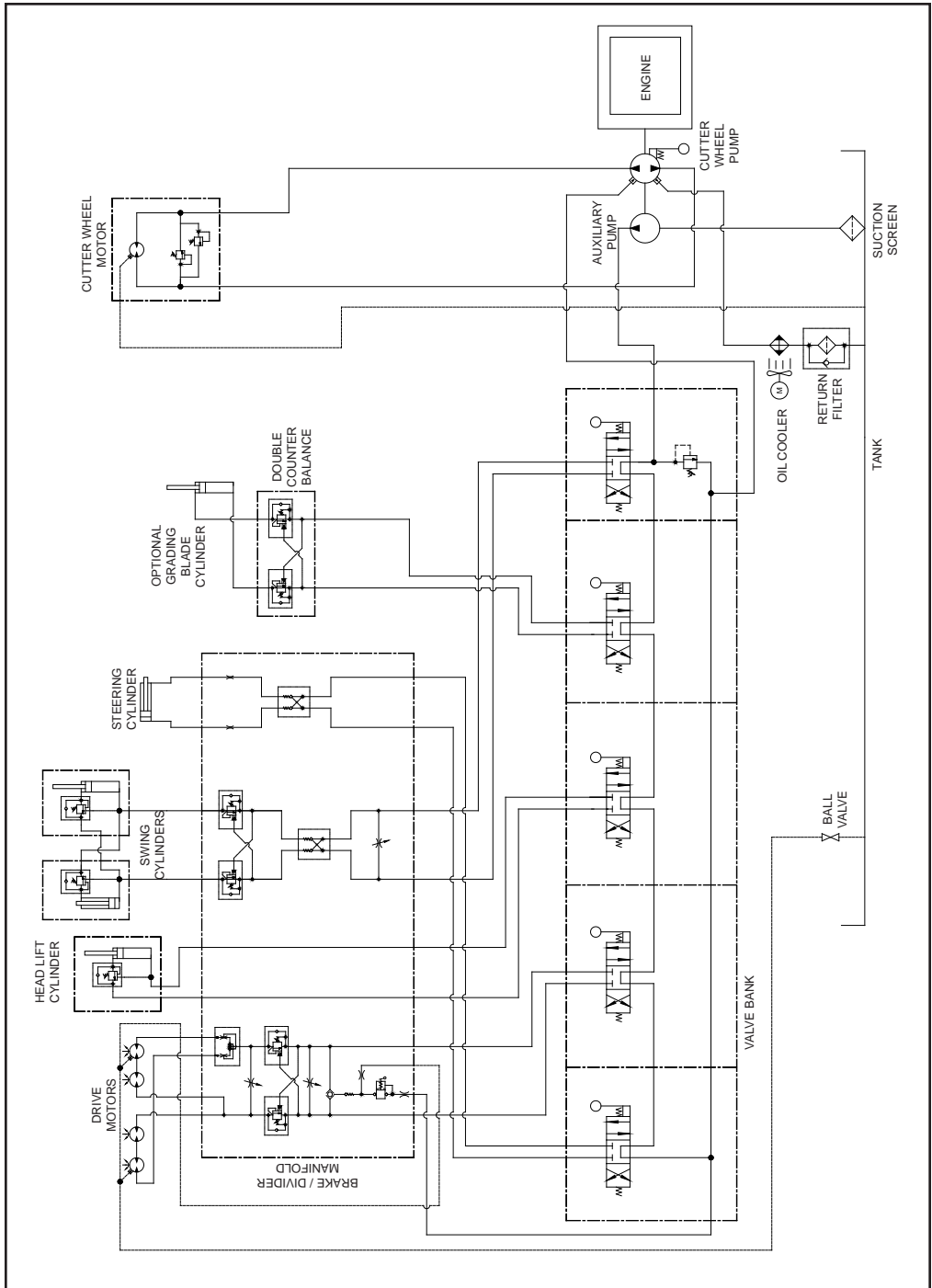

MODEL 2550 - REMOTE CONTROL

SPECIFIC SCHEMATIC FUNCTION MAY VARY DEPENDING ON OPTIONS OR COMPONENT MANUFACTURE.

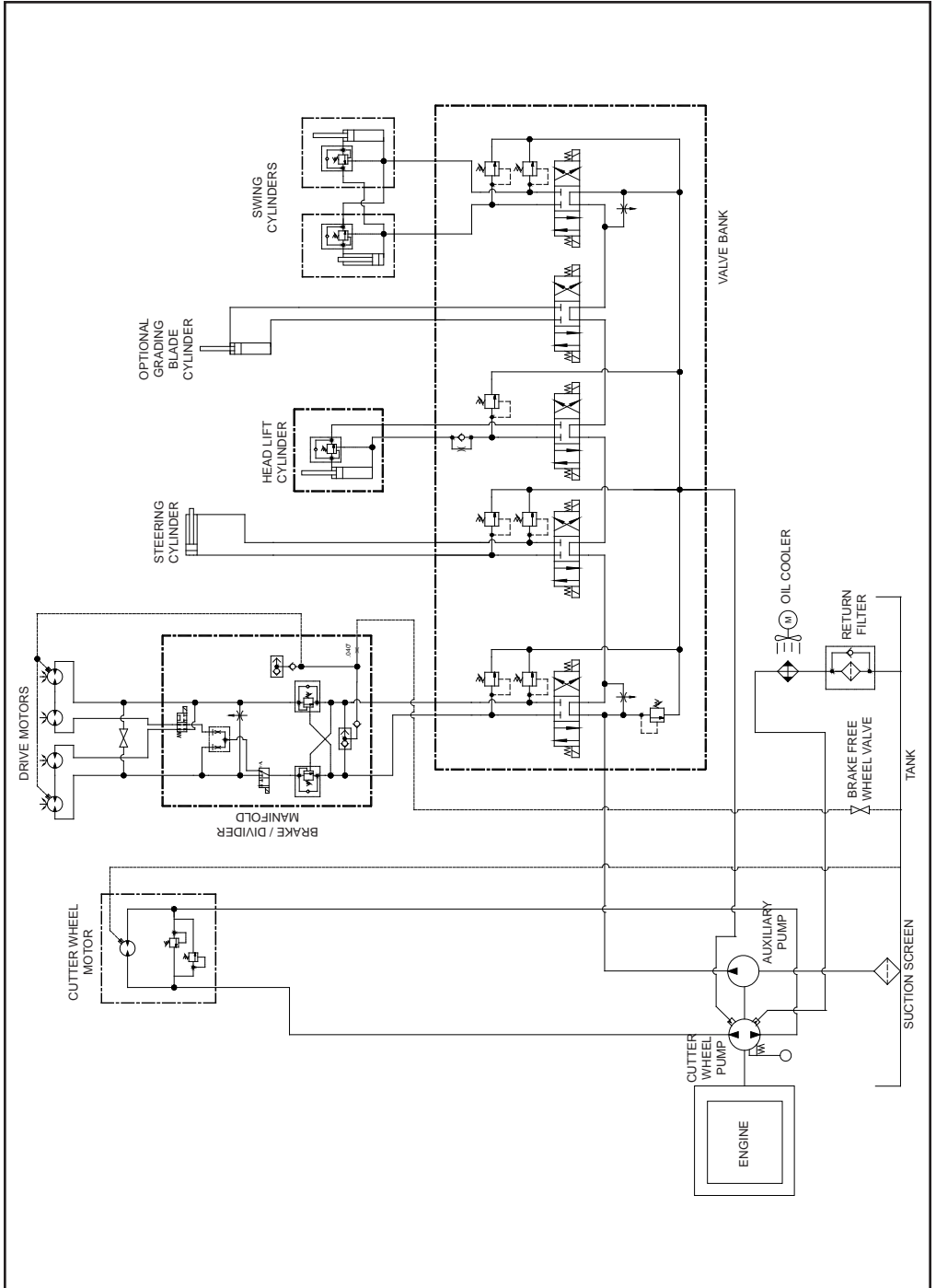

MODEL 2550T - SWING OUT CONTROLS

SPECIFIC SCHEMATIC FUNCTION MAY VARY DEPENDING ON OPTIONS OR COMPONENT MANUFACTURE.

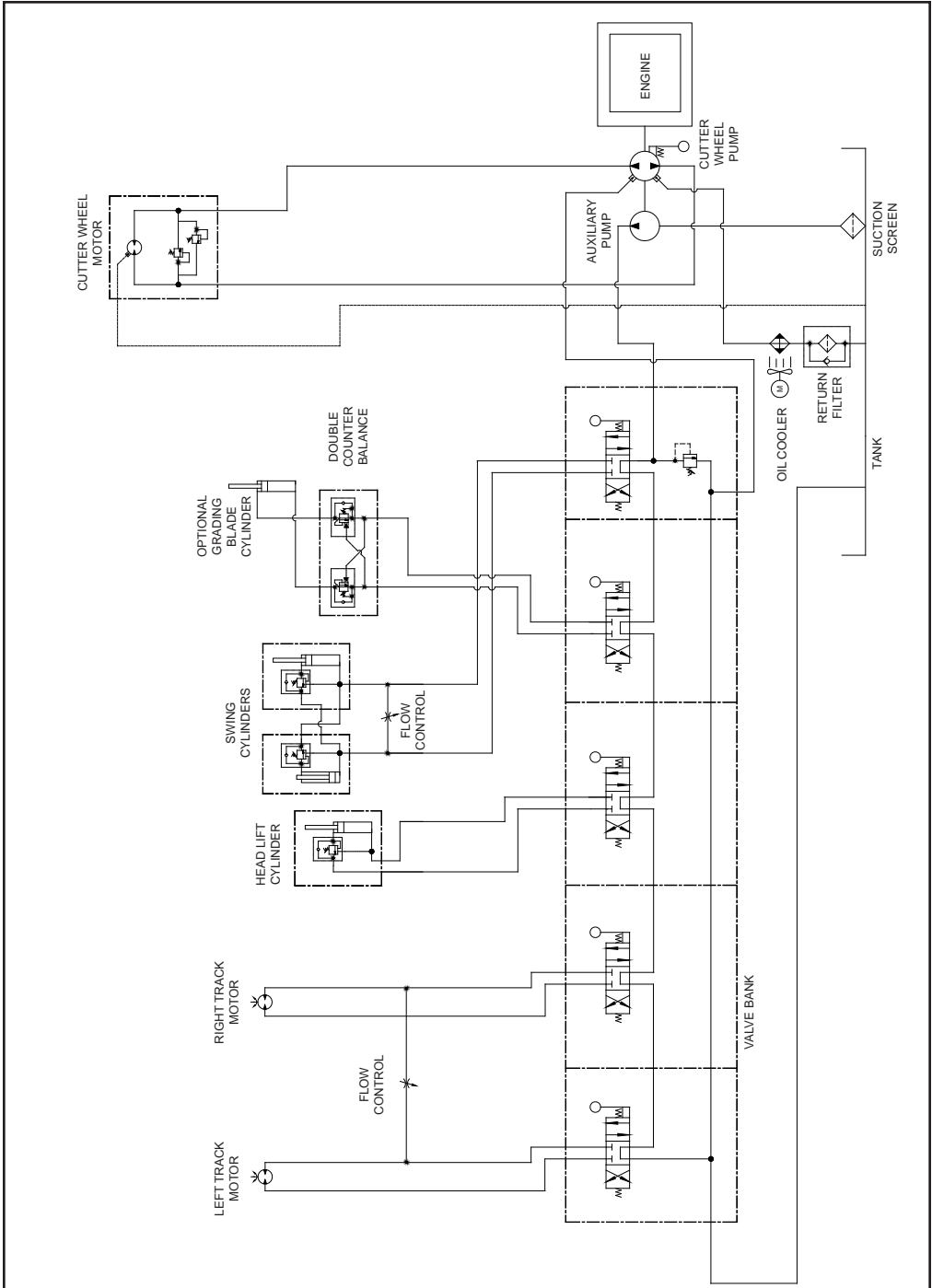

MODEL 2550T - REMOTE CONTROL

SPECIFIC SCHEMATIC FUNCTION MAY VARY DEPENDING ON OPTIONS OR COMPONENT MANUFACTURE.

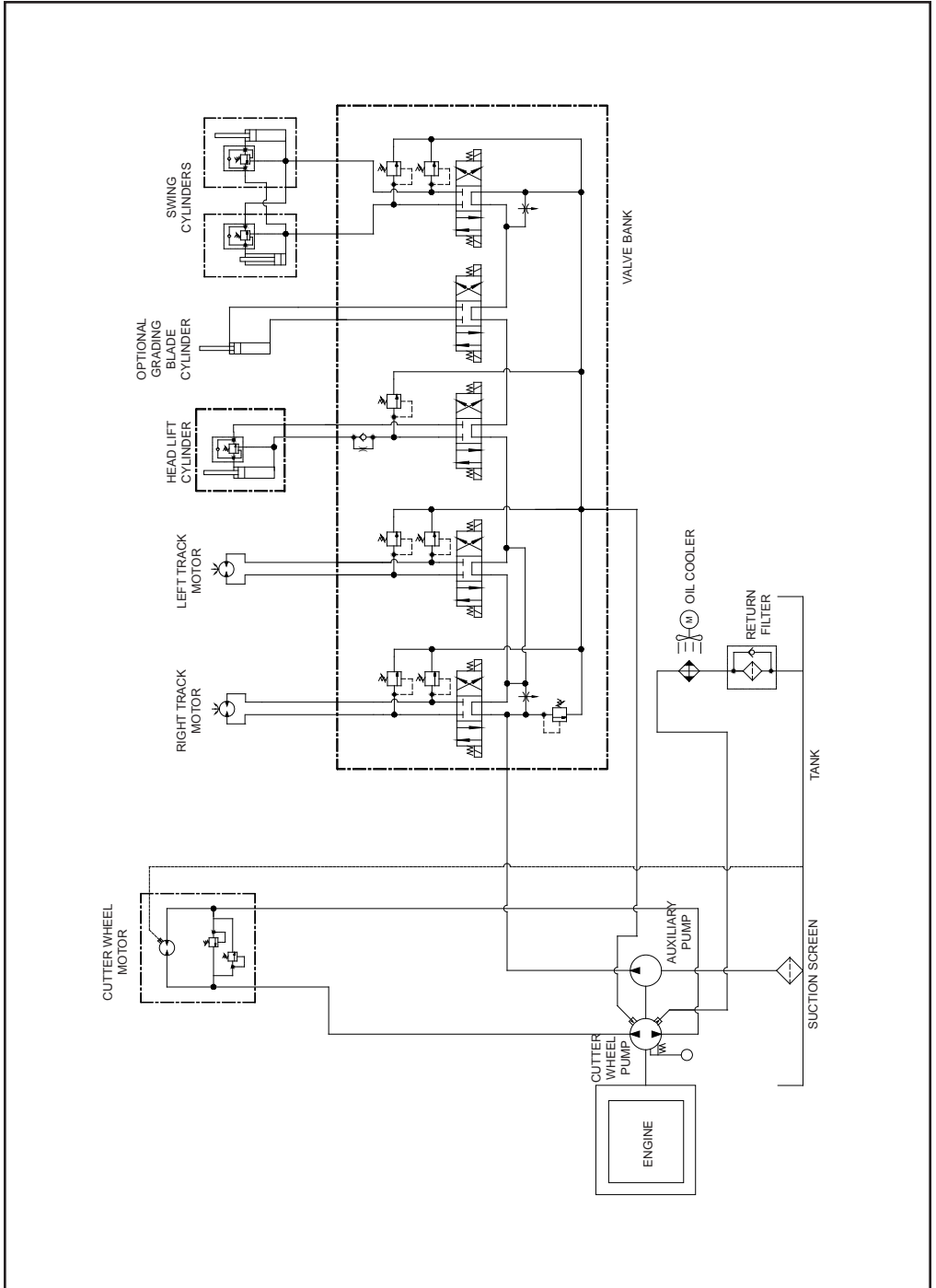

HYDRAULIC SYSTEM TROUBLE SHOOTING

Before attempting any type of maintenance disengage clutch, turn off engine, wait for the cutter wheel to come to a complete stop, install the cutter wheel lock pin, place the cutter wheel on the ground, disconnect battery, and make sure the ignition key is in your possession.

PROBLEM	POSSIBLE CAUSE	SOLUTION
Hydraulic oil very hot, causing system to operate slowly.	<ol style="list-style-type: none"> 1. Dull teeth. 2. Low oil level. 3. Worn pump. 4. Poor oil quality. 5. Damaged hose. 6. Oil suction screen or filter plugged. 7. Oil cooler plugged. 8. Binding. 	<ol style="list-style-type: none"> 1. Replace teeth. 2. Fill 7/8 full minimum. 3. Replace. 4. Replace. 5. Replace. 6. Replace. 7. Clean. 8. Repair.
Hydraulic system loss of power.	<ol style="list-style-type: none"> 1. Low oil level. 2. Cable out of adjustment. 3. Poor oil quality. 4. Bad cylinder. 5. Bad pump. 6. Bad motor. 7. Relief stuck open. 	<ol style="list-style-type: none"> 1. Fill 7/8 full minimum. 2. Adjust or replace. 3. Replace. 4. Replace or repair. 5. Replace. 6. Repair or replace. 7. Clean or replace.
Hydrostatic motor is leaking.	<ol style="list-style-type: none"> 1. Bad shaft seal. 2. Loose or cracked fitting. 	<ol style="list-style-type: none"> 1. Replace and check for back pressure. 2. Tighten or replace.
Swing cylinder loss of power.	<ol style="list-style-type: none"> 1. Cutter wheel speed adjustment screw turned wide open. 2. Bad cylinder. 	<ol style="list-style-type: none"> 1. Screw in speed adjustment screw to close bypass. Readjust for "no bounce" cutting. 2. Repair or replace.
Cutter wheel swings faster one way than the other way.	<ol style="list-style-type: none"> 1. Counter balance valve is out of adjustment. 2. Bad cylinder. 	<ol style="list-style-type: none"> 1. Replace. 2. Repair or replace.
Cutter wheel does not stay in up position, creeps down.	<ol style="list-style-type: none"> 1. Counter balance is out of adjustment. 2. Bad cylinder. 	<ol style="list-style-type: none"> 1. Adjust counter balance valve or replace counter balance cartridge. 2. Repair or replace.
Cutter wheel turns while disengaged.	<ol style="list-style-type: none"> 1. Cutter wheel engagement lever cable too tight. 	<ol style="list-style-type: none"> 1. Adjust cable so that the cutter wheel engages and disengages completely.

NOTICE

In cold weather situations, let the hydraulic system idle for approximately 15 minutes to allow the system to warm up to operating temperature. Running cold oil through the hydrostatic motor can raise the case drain pressures and damage the shaft seals.

NOTICE

When returning hydraulic components for warranty make sure to box up all warranted parts to avoid additional damage while shipping. **Do not disassemble any hydraulic components which are to be warranted.** Anything which has been disassembled or tampered with will not be warranted. Items being returned must be clean. All hydraulic components must have all hosing ports plugged. Failure to plug ports will allow debris to enter components which will void warranty.

NEW RIVER “REVOLUTION” CUTTER WHEEL

DO NOT OPERATE MACHINE WITHOUT A FULL SET OF TEETH. OPERATING MACHINE WITHOUT A FULL SET OF TEETH CAN CAUSE EXCESSIVE VIBRATION AND PREMATURE BEARING FAILURE.

Use only original equipment manufacturer’s teeth. The use of any other aftermarket teeth may cause damage or premature failure to the drive train.

There are twenty-four (24) teeth, twenty-four (24) tooth nuts, and sixteen (16) holders to a complete set on a model 2550 or 2550T. Twenty-four (24) teeth: eight (8) lead teeth (shorts) and sixteen (16) side teeth (longs). Sixteen (16) holders: eight (8) holders without locator pin and eight (8) holders with locator pin.

A locking pin is provided to hold the cutter wheel in position during tooth removal and reinstallation. Locking pin will only lock on outer teeth.

⚠ DANGER

NEVER USE HAND ON CUTTER WHEEL TO HOLD IN PLACE WHILE CHANGING TEETH. BE SURE TO REMOVE LOCKING PIN BEFORE OPERATING THE MACHINE.

NOTICE

Do Not operate machine with extremely worn or broken teeth.

TOOTH ARRANGEMENT

Inspect teeth, nuts and pockets for damage and replace as required.

When replacing teeth, always replace new teeth across from each other (180°) in order to prevent vibration.

Replacement teeth must be carbide tipped and of like design as provided with the machine.

To make sure the correct tooth pattern is used, make sure a pocket with a locator pin is used on a station with a locator pin hole. Use the pockets without the locator pin on a station without the locator pin hole.

When replacing complete set of teeth, be sure to duplicate original factory tooth arrangement, with the carbide tip facing the cutter wheel rotation. Typically a 15/16” socket is required to change or torque the teeth. Torque Lead Teeth to 200 ft.-lbs. (271 Nm) and Side Teeth to 125 ft.-lbs. (169 Nm).

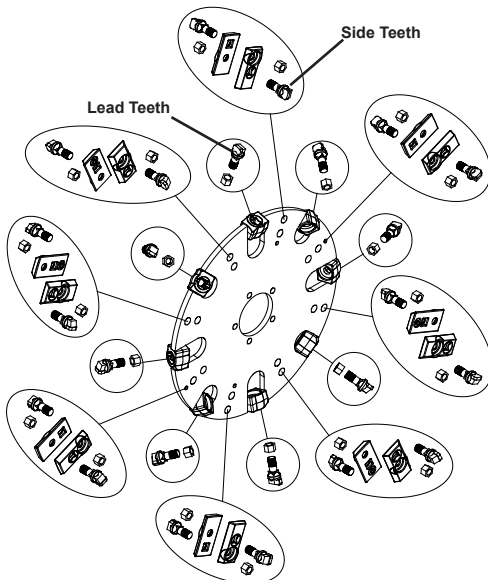

MODELS 2550/2550T

Lead Tooth “Shorts”:	900-9909-96
Side Tooth “Long”:	900-9906-05
Pocket without locator pin	900-9909-98
Pocket with locator pin:	900-9909-97
Tooth Nut:	900-9909-99

CUTTER WHEEL SECTION - GREEN TEETH

DO NOT OPERATE MACHINE WITHOUT A FULL SET OF TEETH. OPERATING MACHINE WITHOUT A FULL SET OF TEETH CAN CAUSE EXCESSIVE VIBRATION AND PREMATURE BEARING FAILURE.

Use only original equipment manufacturer's teeth. The use of any other aftermarket teeth may cause damage or premature failure to the drive train.

There are eighteen (18) teeth and pockets to a complete set on a model 2550 or 2550T. Eighteen (18) teeth, six (6) straight pockets and twelve (12) angle pockets.

A locking pin is provided to hold the cutter wheel in position during tooth removal and reinstallation. Locking pin will only lock on outer teeth.

⚠ DANGER

NEVER USE HAND ON CUTTER WHEEL TO HOLD IN PLACE WHILE CHANGING TEETH. BE SURE TO REMOVE LOCKING PIN BEFORE OPERATING THE MACHINE.

NOTICE

Do Not operate machine with extremely worn or broken teeth.

TOOTH ARRANGEMENT

Inspect pockets, teeth and bolts for damage and replace as required.

When replacing pockets, always replace new pockets across from each other (180°) in order to prevent vibration.

Replacement teeth must be carbide tipped and of like design as provided with the machine.

Use anti-seize on threads to help prevent bolts from "freezing up" in cutter wheel pockets.

When replacing complete set of teeth, be sure to duplicate original factory tooth arrangement, with the carbide tip facing the cutter wheel rotation. Typically a 1/2" allen key socket is required to change or torque the teeth. Torque pocket bolts to 125-150 ft.-lbs. (169-203 Nm). Torque tooth nut to 31-43 ft.-lbs. (42-58 Nm).

All Outside Pockets require a straight pocket mounted on each side of the cutter wheel. There are three outside pockets on each side of the cutter wheel.

All Inside Pockets require an angle pocket mounted away from the cutter wheel.

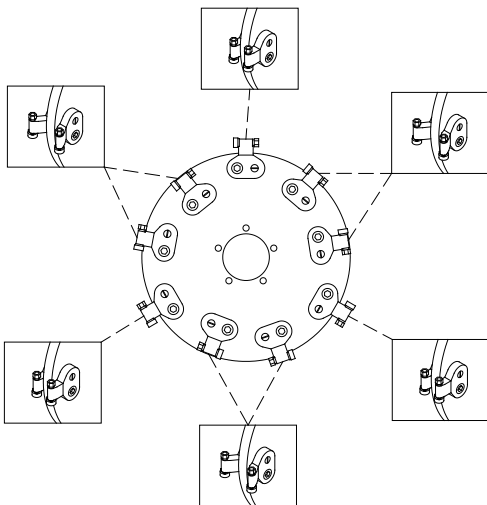

MODELS 2550/2550T

Green Tooth With Nut:	900-9907-91
Red Tooth With Nut:	900-9907-92
Straight Pocket:	900-9907-87
Angle Pocket:	900-9907-86
Pocket Bolt:	900-9907-14
18 Green Tooth Kit:	900-9908-24

CUTTER WHEEL SECTION - TOMAHAWK

DO NOT OPERATE MACHINE WITHOUT A FULL SET OF TEETH. OPERATING MACHINE WITHOUT A FULL SET OF TEETH CAN CAUSE EXCESSIVE VIBRATION AND PREMATURE BEARING FAILURE.

Use only original equipment manufacturer's teeth. The use of any other aftermarket teeth may cause damage or premature failure to the drive train.

There are eighteen (18) teeth and mounting blocks to a complete set on a model 2550 or 2550T. Eighteen (18) teeth: six (6) straight teeth, six (6) right teeth, and six (6) left teeth. Eighteen (18) mounting blocks: nine (9) c'bored mounting blocks and nine (9) threaded mounting blocks.

A locking pin is provided to hold the cutter wheel in position during tooth removal and reinstallation. Locking pin will only lock on outer teeth.

⚠ DANGER

NEVER USE HAND ON CUTTER WHEEL TO HOLD IN PLACE WHILE CHANGING TEETH. BE SURE TO REMOVE LOCKING PIN BEFORE OPERATING THE MACHINE.

NOTICE

Do Not operate machine with extremely worn or broken teeth.

TOOTH ARRANGEMENT

Inspect pockets, teeth and bolts for damage and replace as required.

When replacing pockets, always replace new pockets across from each other (180°) in order to prevent vibration.

Replacement teeth must be carbide tipped and of like design as provided with the machine.

Use anti-seize on threads to help prevent bolts from "freezing up" in cutter wheel pockets.

When replacing complete set of teeth, be sure to duplicate original factory tooth arrangement, with the carbide tip facing the cutter wheel rotation. Typically a 1/2" allen key socket is required to change or torque the teeth. Torque tooth bolts to 125-150 ft.-lbs. (169-203 Nm).

All Outside Pockets require a straight pocket mounted on each side of the cutter wheel. There are three outside pockets on each side of the cutter wheel.

All Inside Pockets require an angle pocket mounted away from the cutter wheel.

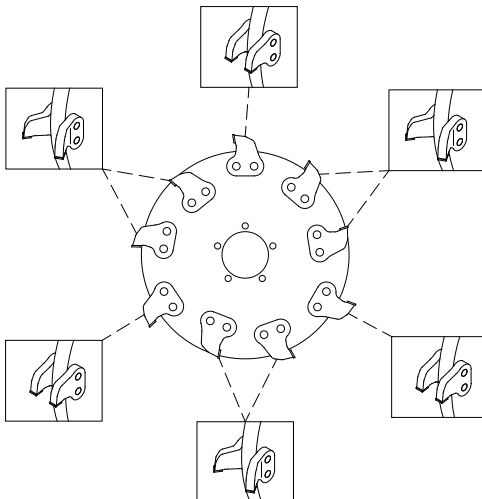

MODELS 2550/2550T

Tomahawk Straight Tooth:	900-9903-82
Tomahawk Left Tooth:	900-9903-83
Tomahawk Right Tooth:	900-9903-84
C'Bored Mounting Block:	900-9903-85
Threaded Mounting Block:	900-9903-86
Pocket Bolt:	900-9903-80

MODEL 2550 SWING OUT CONTROLS



30 Amp Blade Type Fuse

12 Volt Sealed Relay

Swing Out Switch

MACHINE HARNESS - GAS ENGINE & SWING OUT CONTROLS (203-8000-14)

MACHINE HARNESS - DIESEL ENGINE & SWING OUT CONTROLS (203-8000-16)

SWING OUT HARNESS TO SELECTOR VALVE (203-8000-15)

MODEL 2550 REMOTE CONTROLS



12 Volt Sealed Relay

Remote Link Light

30 Amp Blade Type Fuse

12 Volt Sealed Relay

Remote / Tether Toggle Switch

MACHINE HARNESS - DIESEL ENGINE & LOR REMOTE CONTROLS (203-8000-11)

MACHINE HARNESS - DIESEL ENGINE & KAR-TECH / OMNEX REMOTE CONTROLS (203-8000-13)

MACHINE HARNESS - GAS ENGINE & LOR REMOTE CONTROLS (203-8000-10)

MACHINE HARNESS - GAS ENGINE & KAR-TECH / OMNEX REMOTE CONTROLS (203-8000-12)

DRIVE FORWARD VALVE HARNESS - REMOTE CONTROLS (991-8000-16)

DRIVE FORWARD VALVE HARNESS - REMOTE CONTROLS (991-8000-17)

MODEL 2550T SWING OUT CONTROLS



30 Amp Blade Type Fuse

12 Volt Sealed Relay

Swing Out Switch

MACHINE HARNESS - GAS ENGINE & SWING OUT CONTROLS (203-8000-14)

MACHINE HARNESS - DIESEL ENGINE & SWING OUT CONTROLS (203-8000-16)

SWING OUT HARNESS TO SELECTOR VALVE (203-8000-15)

MODEL 2550T REMOTE CONTROLS



12 Volt Sealed Relay

Remote Link Light

30 Amp Blade Type Fuse

12 Volt Sealed Relay

Remote / Tether Toggle Switch

MACHINE HARNESS - DIESEL ENGINE & KAR-TECH REMOTE CONTROLS (203-8000-26)

MACHINE HARNESS - GAS ENGINE & KAR-TECH REMOTE CONTROLS (xxx-xxxx-xx)

DRIVE FORWARD VALVE HARNESS - REMOTE CONTROLS (203-8000-28)

DRIVE FORWARD VALVE HARNESS - REMOTE CONTROLS (203-8000-29)

2550 MACHINE HARNESS - GAS ENGINE & LOR REMOTE CONTROLS (203-8000-10)

SPECIFIC SCHEMATIC FUNCTION MAY VARY DEPENDING ON OPTIONS OR COMPONENT MANUFACTURE.

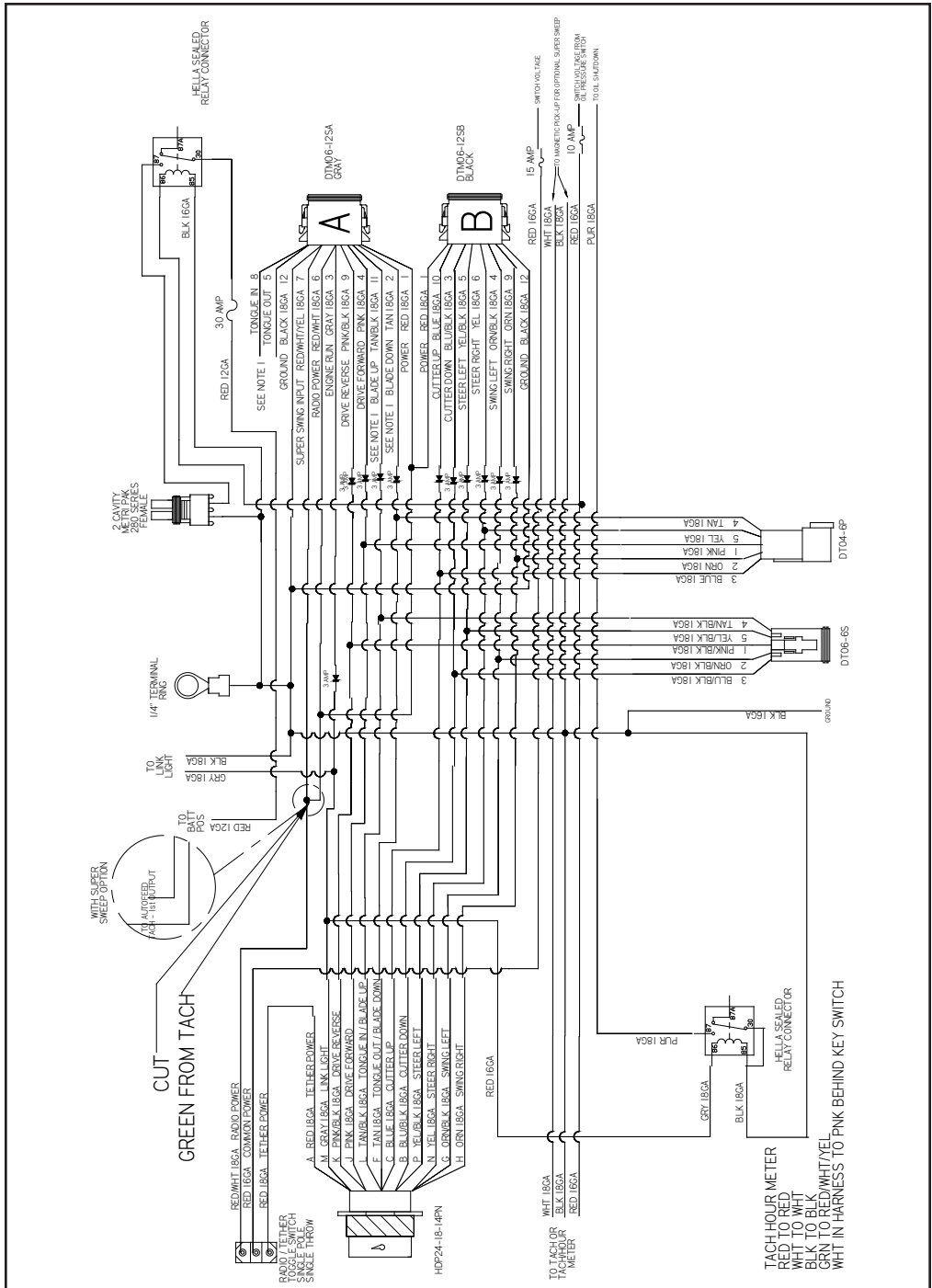

DRIVE FORWARD VALVE HARNESS

MODEL 2550 (991-8000-16)

SPECIFIC SCHEMATIC FUNCTION MAY VARY DEPENDING ON OPTIONS OR COMPONENT MANUFACTURE.

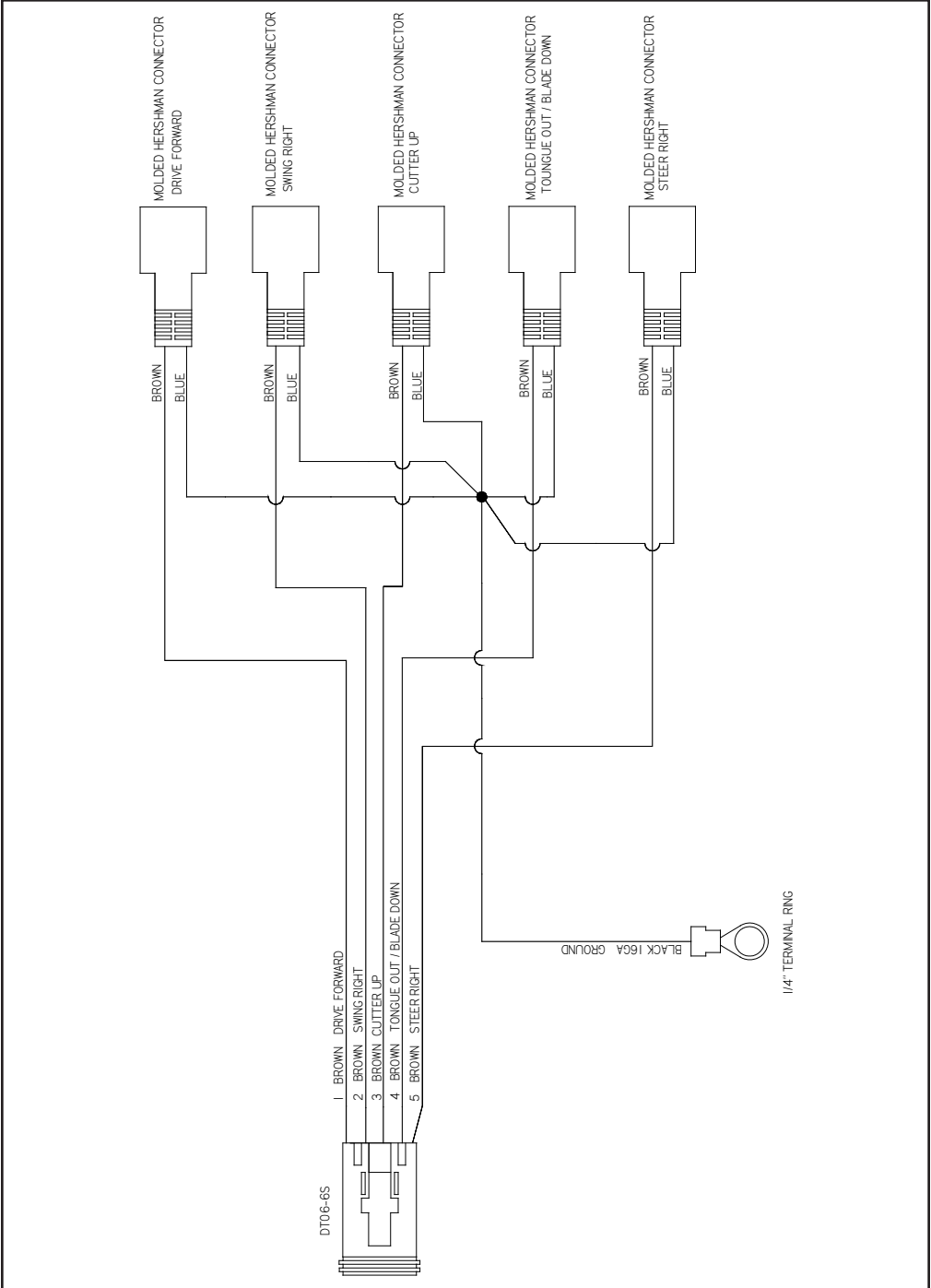

DRIVE REVERSE VALVE HARNESS

MODEL 2550 (991-8000-17)

SPECIFIC SCHEMATIC FUNCTION MAY VARY DEPENDING ON OPTIONS OR COMPONENT MANUFACTURE.

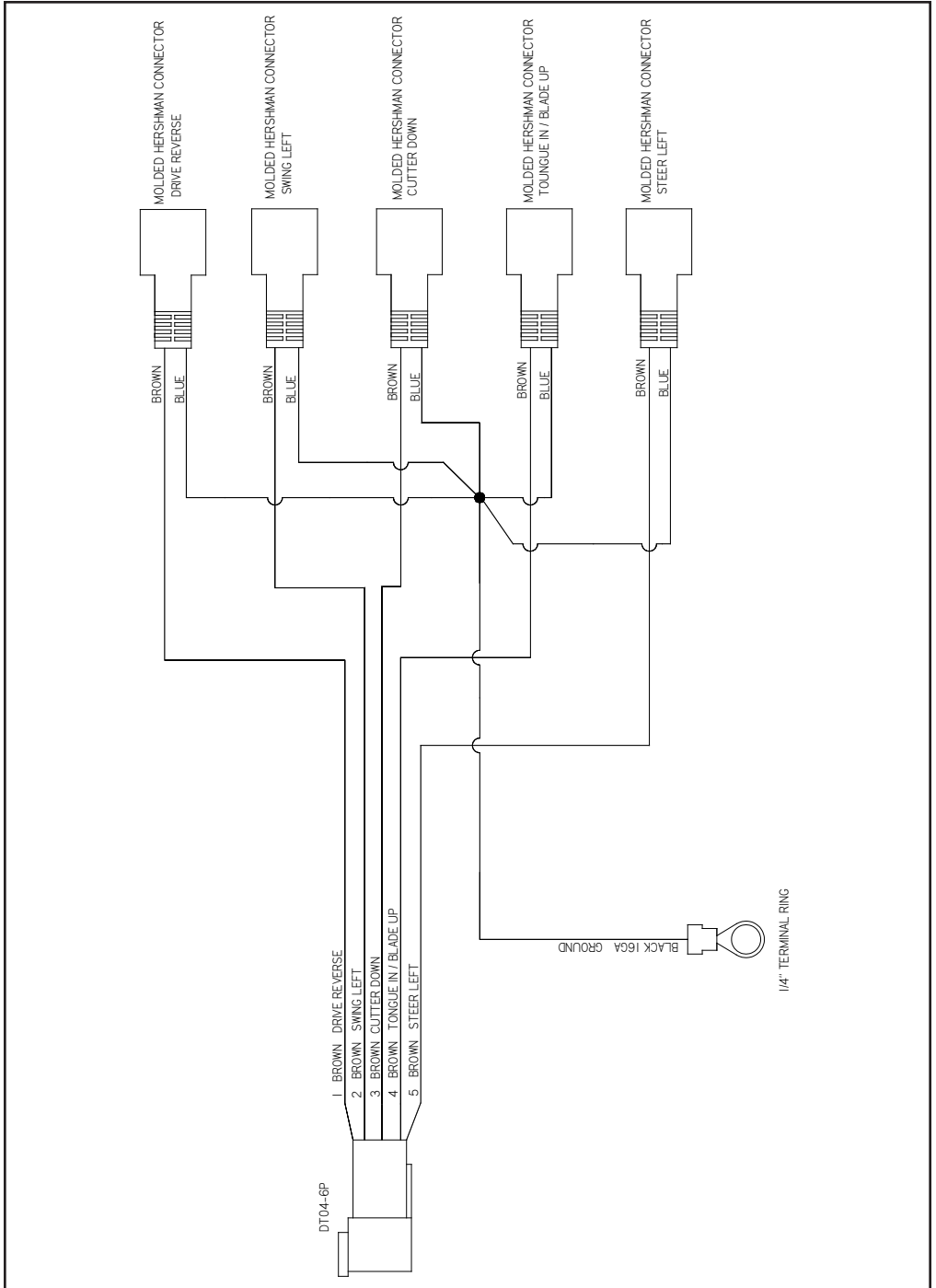

DRIVE FORWARD VALVE HARNESS

MODEL 2550T (203-8000-28)

SPECIFIC SCHEMATIC FUNCTION MAY VARY DEPENDING ON OPTIONS OR COMPONENT MANUFACTURE.

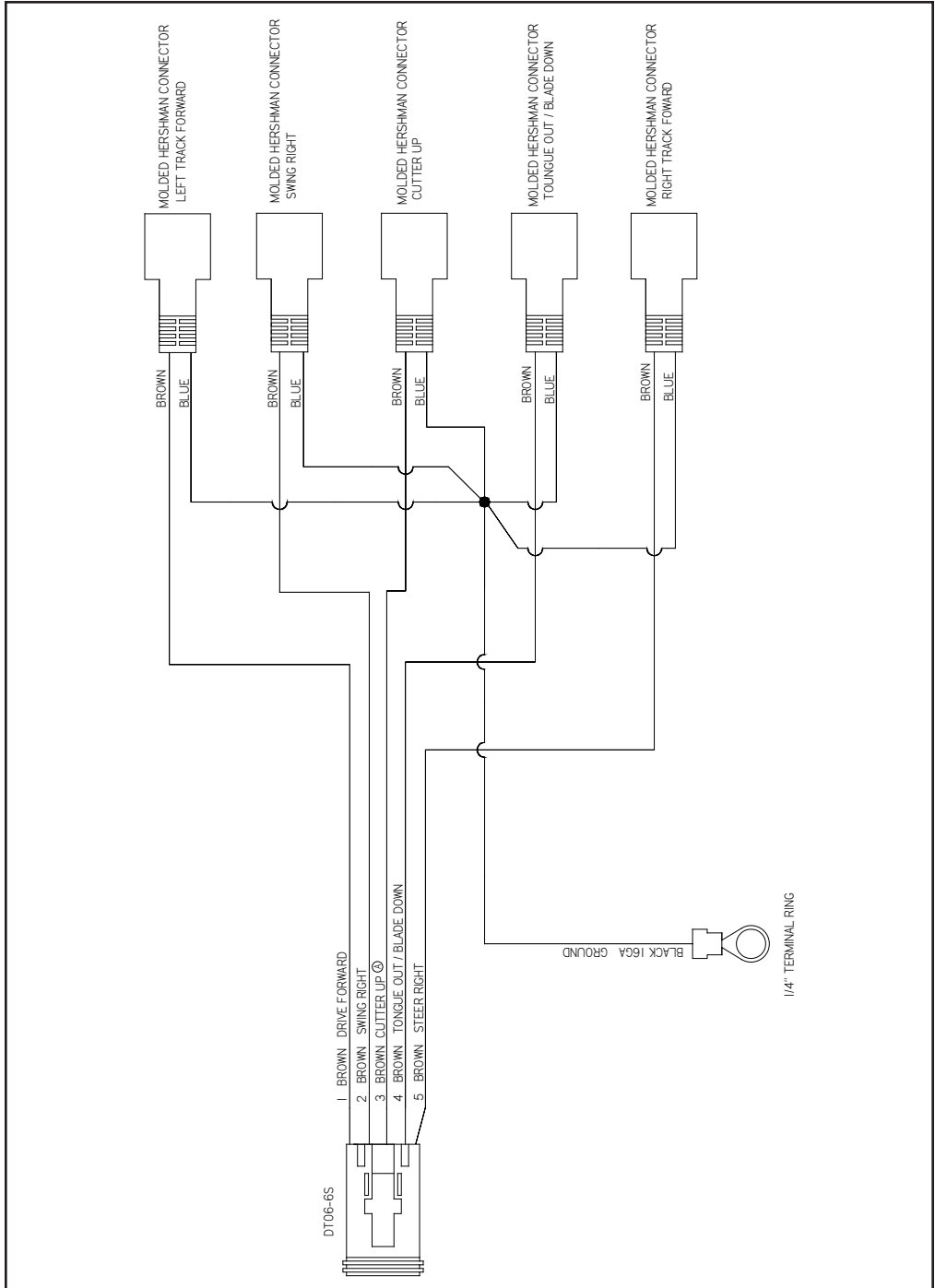

DRIVE REVERSE VALVE HARNESS

MODEL 2550T (203-8000-29)

SPECIFIC SCHEMATIC FUNCTION MAY VARY DEPENDING ON OPTIONS OR COMPONENT MANUFACTURE.

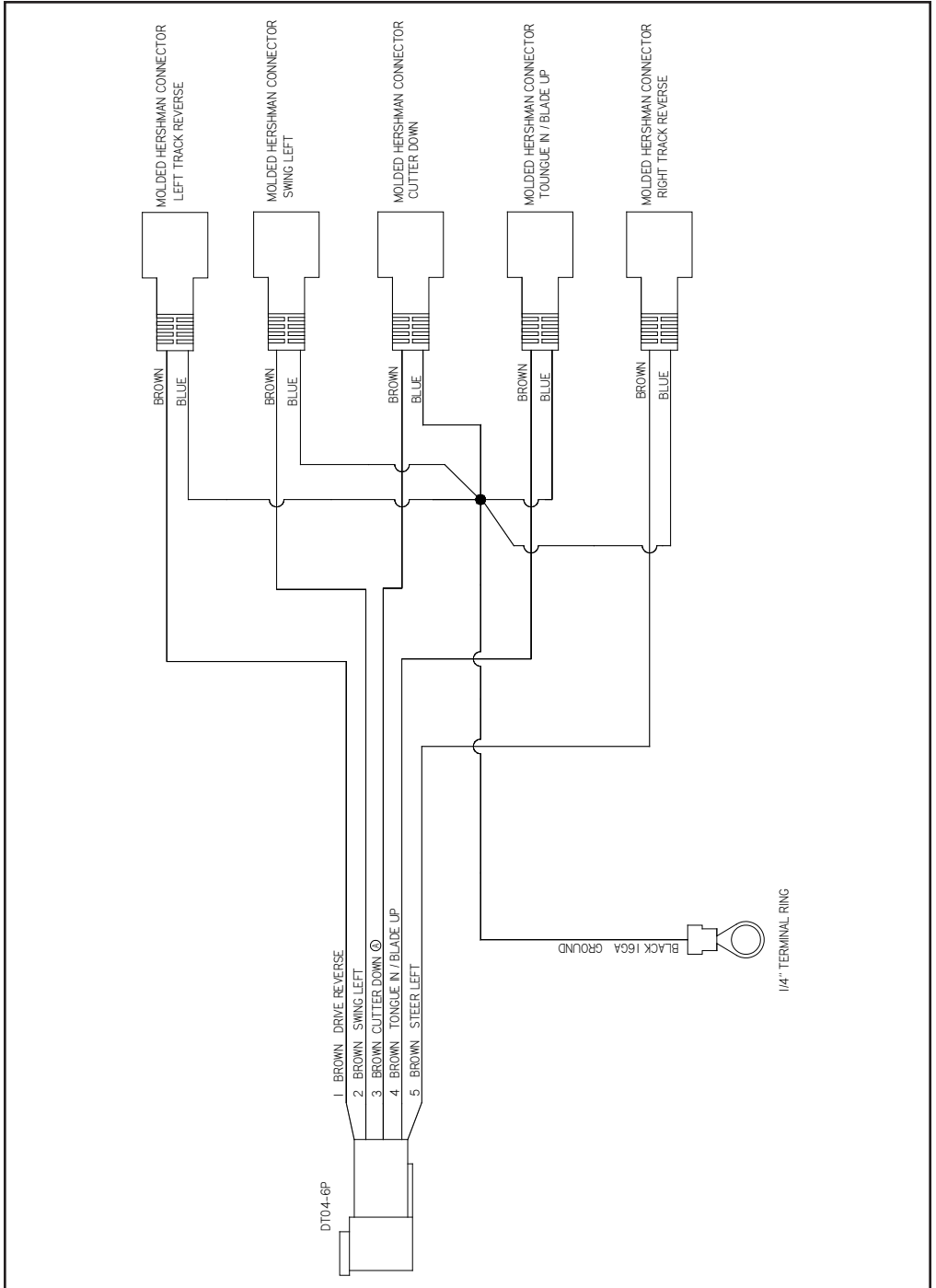

MACHINE HARNESS - GAS ENGINE & SWING OUT CONTROLS (203-8000-14)

SPECIFIC SCHEMATIC FUNCTION MAY VARY DEPENDING
ON OPTIONS OR COMPONENT MANUFACTURE.

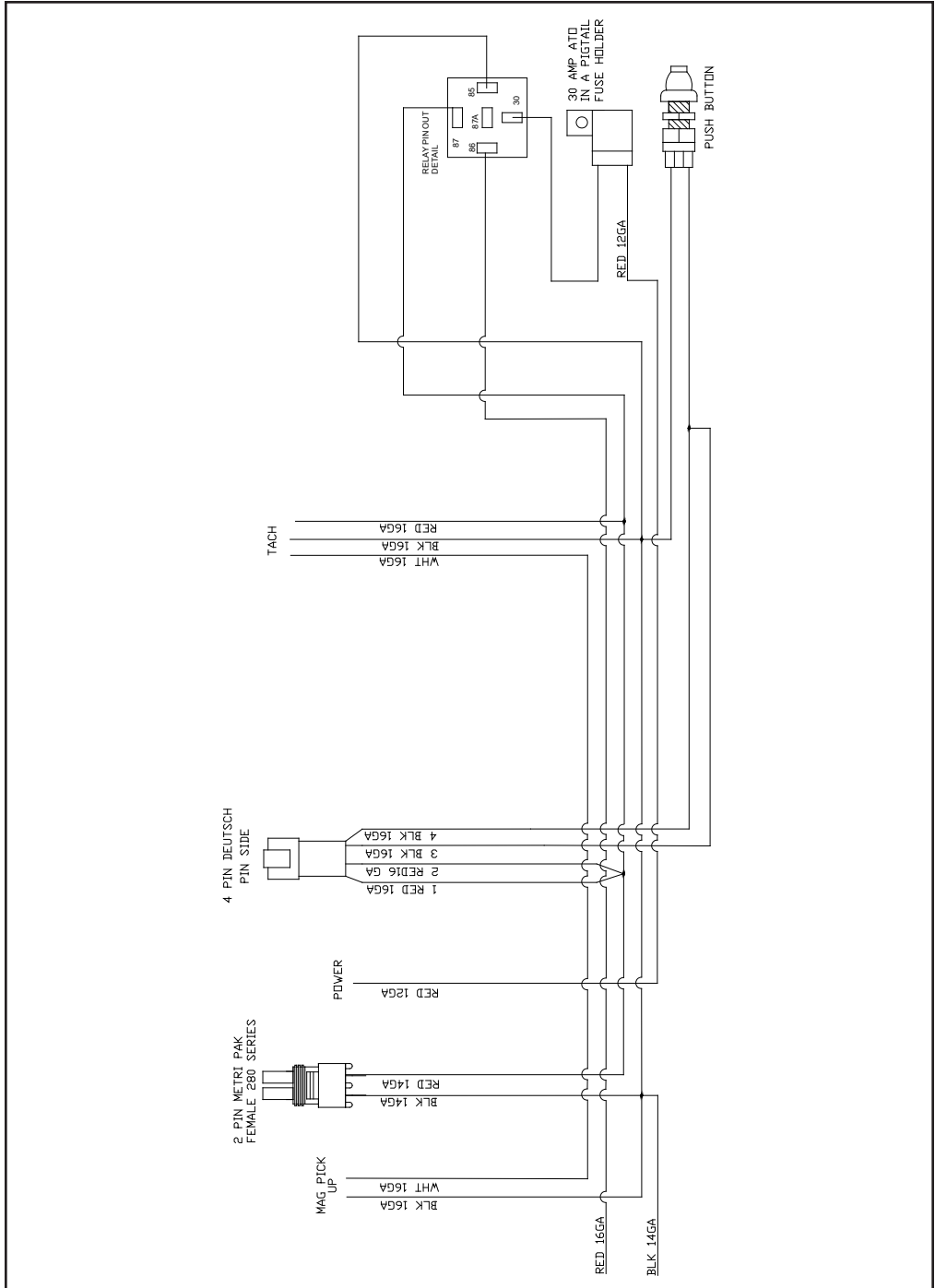

MACHINE HARNESS - DIESEL ENGINE & SWING OUT CONTROLS (203-8000-16)

SPECIFIC SCHEMATIC FUNCTION MAY VARY DEPENDING ON OPTIONS OR COMPONENT MANUFACTURE.

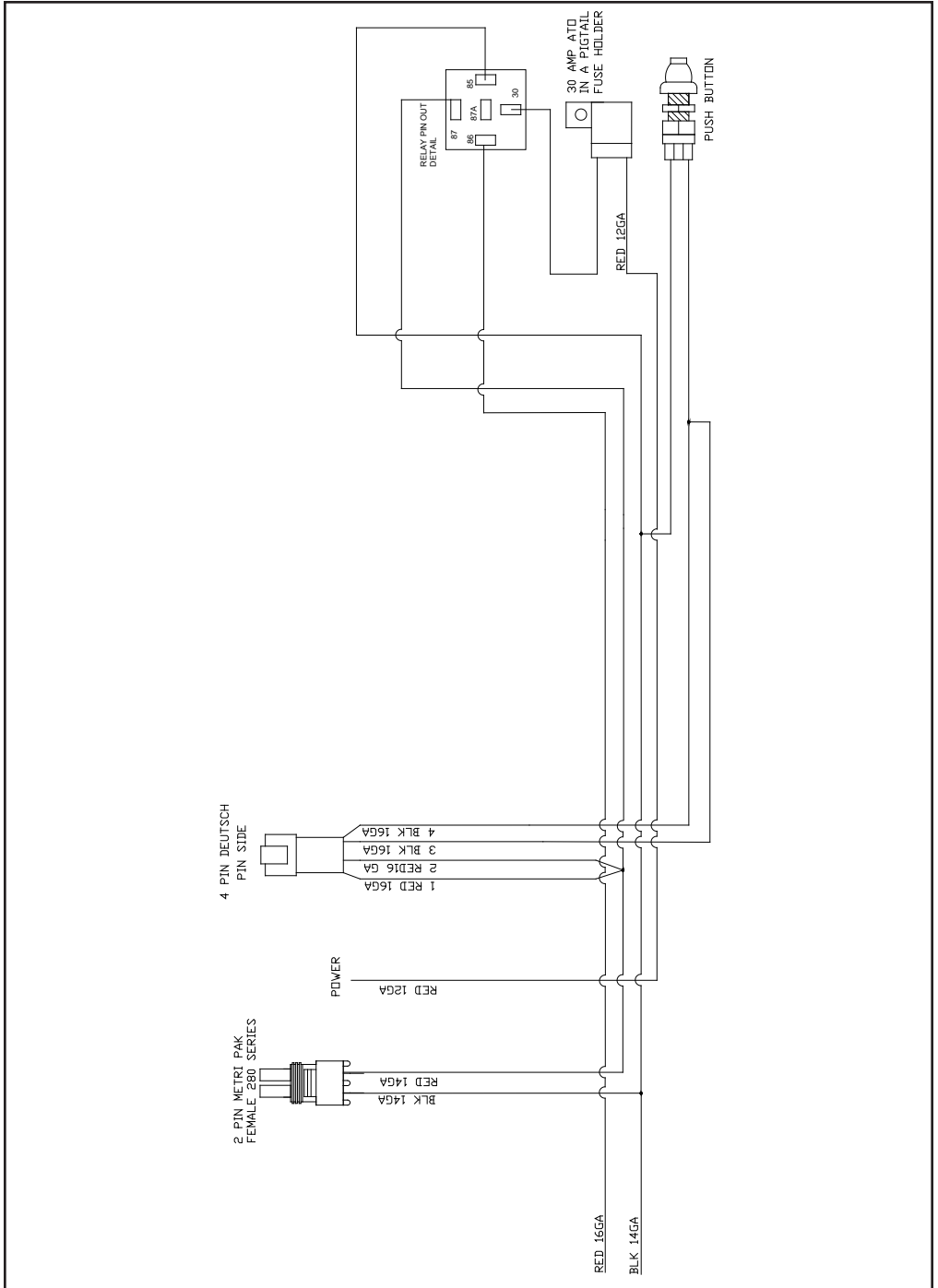

LUBRICATION & COOLANT

1. **Engine:** Follow original equipment manufacturer's requirements for both changing oils and filters, refer to engine manual specifications.
2. **Engine Coolant:** Refer to engine manufacturer's manual specifications.
3. **Hydraulic Reservoir Tank:** Completely change hydraulic oil, suction screen(s), and flush the tank annually. Change hydraulic oil filter(s) AFTER FIRST 10 HOURS OF OPERATION. Then change hydraulic oil filter(s) every 3 months or 400 hours thereafter. Maintain hydraulic oil level 7/8 full. See hydraulic oil requirements below. Check hydraulic oil level in tank daily.
4. **High Pressure & Charge Filters:** Change high pressure and charge filters AFTER FIRST 10 HOURS OF OPERATION. Then change high pressure and charge filter every 3 months or 400 hours thereafter.
5. **Hydraulic Fluid Requirements:** See pages 41 - 42 for hydraulic fluid requirements.
6. **Cutter Wheel Arm Pivot Bushings:** Grease cutter wheel arm up and down pivot bushings daily with one (1) to two (2) shots of EP-2 Lithium type grease. Wipe off excess grease. **Excessive grease will attract dirt.**
7. **Swing Pivot Assembly Bushings:** Grease top and bottom swing pivot assembly bushings weekly with one (1) to two (2) shots of EP-2 Lithium type grease. Wipe off excess grease. **Excessive grease will attract dirt.**
8. **Steering Axle Pivot Bushings (Model 2550 Only):** Grease steering axle pivot bushings weekly with one (1) to two (2) shots of EP-2 Lithium type grease. Wipe off excess grease. **Excessive grease will attract dirt.**
9. **Steering Bushings (Model 2550 Only):** Grease steering bushings weekly with one (1) to two (2) shots of EP-2 Lithium type grease. Wipe off excess grease. **Excessive grease will attract dirt.**
10. **Cylinder Lug Pin Bushings:** Grease cylinder lug pin bushings weekly with one (1) to two (2) shots of EP-2 Lithium type grease. Wipe off excess grease. **Excessive grease will attract dirt.**
11. **Swing Out Pivot Bushings:** Grease swing out pivot bushings weekly with one (1) to two (2) shots of EP-2 Lithium type grease. Wipe off excess grease. **Excessive grease will attract dirt.**
12. **Steel Friction Areas:** Lubricate all steel friction areas including, but not limited to pivoting, hinged, sliding, and rotating areas weekly. (i.e. cutter wheel guard, control box doors, swing out pivot, etc.).
13. **Grading Blade Bushings (if equipped):** Grease grading blade bushings monthly with one (1) to two (2) shots of EP-2 Lithium type grease. Wipe off excess grease. **Excessive grease will attract dirt.**
14. **Cutter Wheel Engagement Lever Cable:** Lubricate the inner cable and cable ends with a cable lube or SAE 10W/30 oil every month. Replace cutter wheel engagement lever cable if it doesn't operate smoothly.
15. **Wheel Hub Bearings (Model 2550 2 Wheel Drive Only):** Inspect and clean the wheel hub bearings, cups, and seals. Replace seals if ever removed. Grease wheel bearings with an EP-2 Lithium type grease. Remove rubber plug and pump grease into E-Z Lube zerk until all of old grease is pumped out of dust cap. Wipe off excess grease and replace rubber plug. **Excessive grease will attract dirt.**

REPLACEMENT PARTS SECTION

Depending on what replacement parts you are ordering the following information will be needed:

GRINDER COMPONENTS

Serial Number
Model Number of Grinder

ENGINE COMPONENTS

Brand
Engine Serial Number
Engine Spec. Number

NOTICE

When ordering any replacement parts you should have the serial number (S/N) and model of the machine to ensure that you receive the correct replacement part. See page 6 for typical serial number & work order number locations.

NOTICE

All nuts, bolts, washers, and many other components can be ordered by physical description.

NOTICE

Some of the components shown in this section are for optional equipment and may not apply to every machine.

NOTICE

Bandit Industries Inc. reserves the right to make changes in models, size, design, installations and applications on any part without notification.

MODEL 2550T

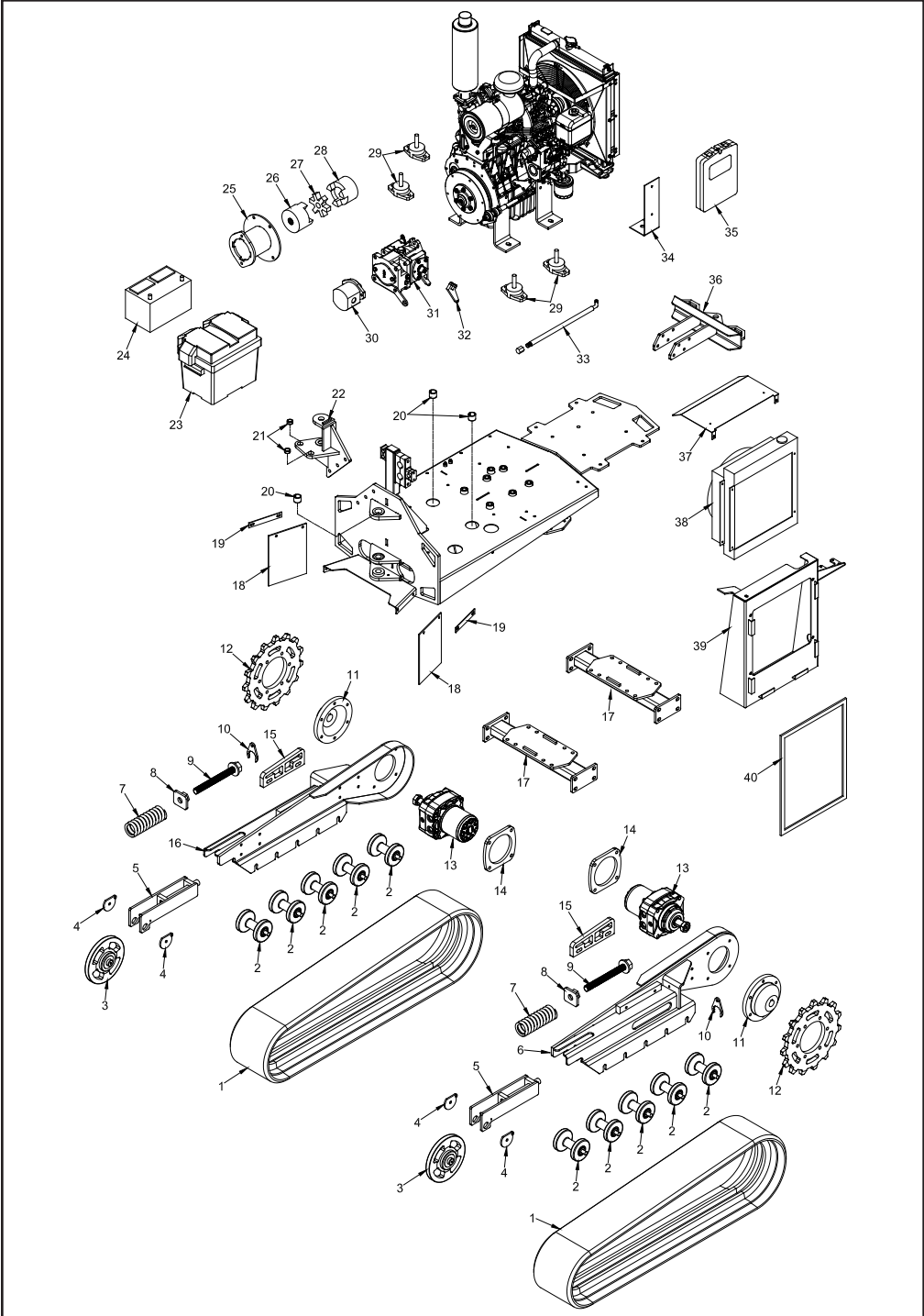

NOTICE Parts may not be exactly as shown.

MODEL 2550T

LOCATION	PART NUMBER	DESCRIPTION
1 a.	900-5911-33	Rubber Track - No Tread
1 b.	900-5913-05	Rubber Track - With Tread
2.	900-5911-26	Small Roller
3.	900-5911-69	Idler Roller
4.	400-3001-24	Idler End Retainer
5.	400-2000-07	Front Idler Mount Assembly
6 a.	402-2000-03	Track Frame Assembly - Road Side
6 b.	402-1000-03	Track Assembly - Road Side (Includes 1-15)
7.	900-4917-27	Tension Spring
8.	400-1000-04	Spring Tension Tab
9.	400-1000-08	Track Adjuster Bolt Assembly
10.	402-3000-13	Track Adjuster Bolt Retainer
11.	402-3000-10	Drive Hub
12.	402-3000-09	Drive Sprocket
13.	900-3959-99	Hydraulic Motor With Brake
14.	402-3000-12	Track Motor Draw Ring
15.	402-3000-14	Top Track Guide
16 a.	402-2000-04	Track Frame Assembly - Curb Side
16 b.	402-1000-04	Track Assembly - Curb Side (Includes 1-5 & 7-15)
17.	203-2000-80	Track Support
18.	203-3003-06	Swing Cylinder Chip Curtain
19.	203-3003-12	Strap for Swing Cylinder Chip Curtain
20.	900-1902-42	Split Bushing - 1-1/4" OD x 1" ID x 1"
21.	900-1916-28	Split Bushing - 1" OD x 3/4" ID x 1/2"
22.	203-2000-84	Swing Out Bolt-On Mount
23.	900-7901-71	Plastic Battery Liner Box
24.	900-6900-01	530 CCA Battery
25 a.	900-3959-57	Cutter Wheel Pump Mount - Kohler Engines Only
25 b.	900-3959-56	Cutter Wheel Pump Mount - Briggs & Stratton (Vanguard) Engines Only
25 c.	900-3959-75	Pump Mount Access Cover
26.	900-3956-12	Cutter Wheel Pump Coupler - Pump Side - Gasoline Engines Only
27.	900-3956-00	Cutter Wheel Pump Coupler Spider - Gasoline Engines Only
28.	900-1916-35	Cutter Wheel Pump Coupler - Engine Side - Gasoline Engines Only
29.	900-6916-26	Engine Isolator
30 a.	900-3956-86	Auxiliary Pump
30 b.	900-3956-87	Auxiliary Pump With 4WD Option
31.	900-3955-97	Cutter Wheel Hydraulic Pump
32.	203-2000-49	Pump Engagement Lever
33 a.	900-3937-80	Engine Oil Drain Hose
33 b.	900-3936-41	Cap for Engine Oil Drain Hose
34.	203-2000-53	Manual Holder Mount
35.	900-9910-28	Manual Holder
36.	203-2000-51	Bumper Assembly
37.	203-2000-71	Oil Cooler Cover
38.	900-3952-11	Oil Cooler
39.	203-2000-40	Oil Cooler Mount & Assembly (Includes 37-40)
40.	904-0007-30	Oil Cooler Screen

NOTICE Nuts, bolts, washers, and all other components can be ordered by physical description.

MODEL 2550

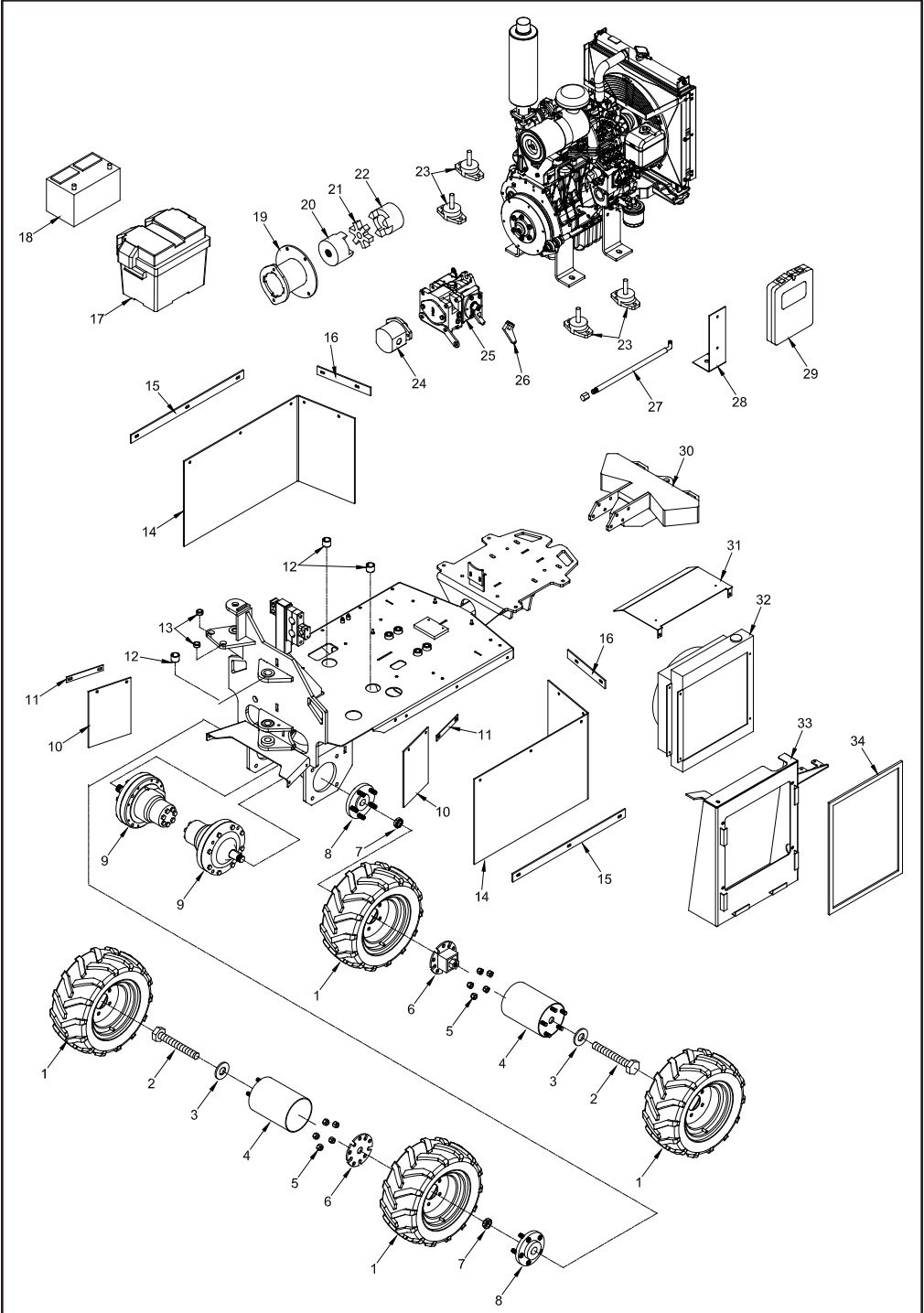

NOTICE Parts may not be exactly as shown.

MODEL 2550

LOCATION	PART NUMBER	DESCRIPTION
1 a.	900-5909-22	18" x 8.50" - 10" Tire & White, 5 Bolt Rim (Specify Left or Right)
b.	900-5909-20	18" x 8.50" - 10" Tire Only
c.	900-5909-21	10" x 6" White, 5 Bolt Rim Only
2.	900-4913-38	1"-8NC x 5 1/2" Hex Head Bolt
3 a.	900-4900-79	1" Flat Washer
b.	900-4908-99	1" Lock Washer (Not Shown)
4 a.	991-2000-81	Dual Wheel Spacer
b.	991-1000-60	Dual Wheel Spacer Kit - Includes 2, 3, 4, 5, & 6
5.	900-4914-00	1/2"-20NF Lug Nut
6.	991-2000-80	Dual Wheel Hub
7.	900-3938-50	1"-20UNEF Hex Slotted Nut
8 a.	991-1000-61	Wheel Hub Assembly
b.	900-5905-97	1/2"-20NF Stud Only
9.	900-3947-20	Hydraulic Motor With Brake
10.	203-3003-06	Swing Cylinder Chip Curtain
11.	203-3003-12	Strap for Swing Cylinder Chip Curtain
12.	900-1902-42	Split Bushing - 1-1/4" OD x 1" ID x 1"
13.	900-1916-28	Split Bushing - 1" OD x 3/4" ID x 1/2"
14.	203-3001-38	Frame Chip Pan Curtain
15.	203-3001-40	Long Chip Pan Strap
16.	203-3001-42	Short Chip Pan Strap
17.	900-7901-71	Plastic Battery Liner Box
18.	900-6900-01	530 CCA Battery
19 a.	900-3959-57	Cutter Wheel Pump Mount - Kohler Engines Only
b.	900-3959-56	Cutter Wheel Pump Mount - Briggs & Stratton (Vanguard) Engines Only
c.	900-3959-75	Pump Mount Access Cover
20.	900-3956-12	Cutter Wheel Pump Coupler - Pump Side - Gasoline Engines Only
21.	900-3956-00	Cutter Wheel Pump Coupler Spider - Gasoline Engines Only
22.	900-1916-35	Cutter Wheel Pump Coupler - Engine Side - Gasoline Engines Only
23.	900-6916-26	Engine Isolator
24 a.	900-3956-86	Auxiliary Pump
b.	900-3956-87	Auxiliary Pump With 4WD Option
25.	900-3955-97	Cutter Wheel Hydraulic Pump
26.	203-2000-49	Pump Engagement Lever
27 a.	900-3937-80	Engine Oil Drain Hose
b.	900-3936-41	Cap for Engine Oil Drain Hose
28.	203-2000-53	Manual Holder Mount
29.	900-9910-28	Manual Holder
30 a.	203-2000-60	Bumper Assembly for Gasoline Engine (Weighted)
b.	203-2000-51	Bumper Assembly (Not Shown)
31.	203-2000-71	Oil Cooler Cover
32.	900-3952-11	Oil Cooler
33.	203-2000-40	Oil Cooler Mount & Assembly (Includes 31-34)
34.	904-0007-30	Oil Cooler Screen

NOTICE Nuts, bolts, washers, and all other components can be ordered by physical description.

MODEL 2550

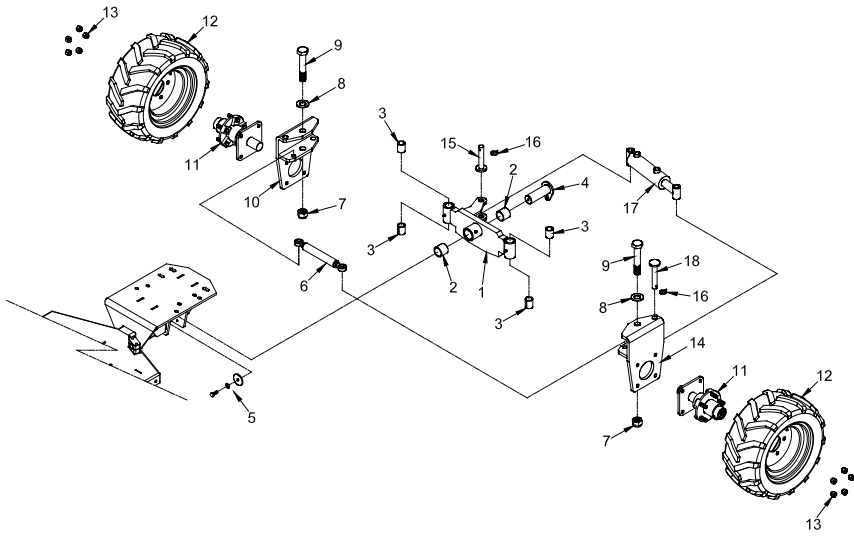

FOUR WHEEL DRIVE OPTION

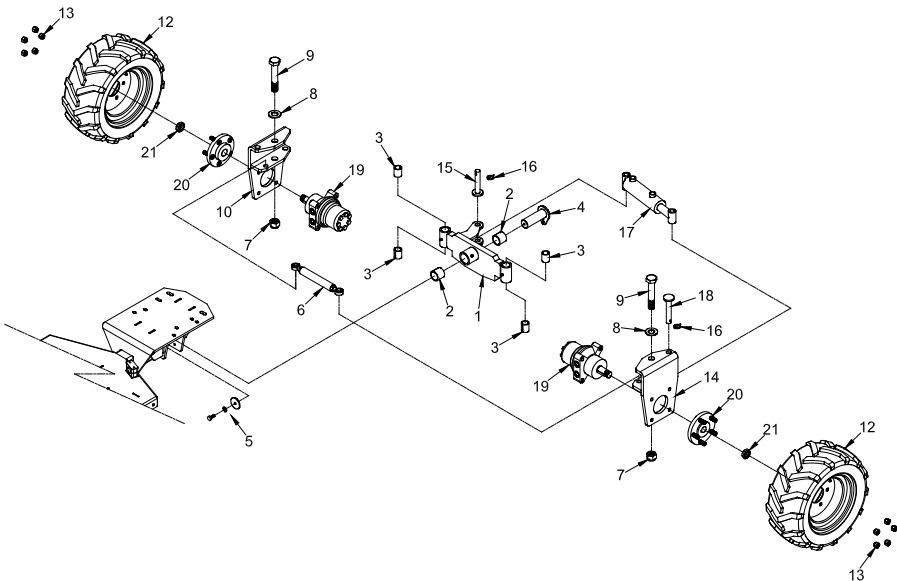

NOTICE Parts may not be exactly as shown.

MODEL 2550

LOCATION	PART NUMBER	DESCRIPTION
1.	203-2000-03	Pivot Steering Mount
2.	900-1908-37	Split Bushing - 1-3/4" OD x 1-1/2" ID x 1-1/2"
3.	900-1902-50	Split Bushing - 1-1/4" OD x 1" ID x 1-1/2"
4.	203-2000-08	Steering Pivot Pin
5 a.	203-3000-79	Pin Retainer Washer
b.	900-4900-13	3/8"-16NC x 1" Hex Head Bolt
c.	900-4906-62	3/8" Lock Washer
6.	203-1000-03	Steering Tie Rod Assembly
7.	900-4900-80	1"-8NC Nylon Insert Hex Lock Nut
8.	900-4904-46	1" Mill Carb Washer
9.	900-4913-38	1"-8NC x 5-1/2" Hex Head Bolt (1-1/4" of Thread) - Special
10.	203-2000-05	Steering Mount - Right (Curb) Side
11 a.	203-2000-06	Spindle Mount
b.	900-5905-37	Hub Assembly
c.	021-041-01	Grease Cap For Hub (Not Shown)
d.	085-001-00	Rubber Cap For Grease Cap (Not Shown)
e.	031-031-02	Inner & Outer Bearing For Hub (Not Shown)
f.	031-031-01	Inner & Outer Bearing Cup For Hub (Not Shown)
g.	010-060-00	Inner & Outer Seal For Hub (Not Shown)
h.	900-5905-97	1/2"-20NF Stud Only
12 a.	900-5909-22	18" x 8.50" - 10" Tire & White, 5 Bolt Rim (Specify Left or Right)
b.	900-5909-20	18" x 8.50" - 10" Tire Only
c.	900-5909-21	10" x 6" White, 5 Bolt Rim Only
13.	900-4914-00	1/2"-20NF Lug Nut
14.	203-2000-04	Steering Mount - Left (Road) Side
15.	993-200023	Steering Cylinder Pin - 4" Long
16.	900-4907-28	3/16" Lynch Pin
17.	900-3937-68	Steering Cylinder
18.	993-200022	Steering Cylinder Pin - 5-1/8" Long
19.	900-3947-21	Hydraulic Motor Without Brake - Four Wheel Drive Option
20 a.	992-1000-30	Wheel Hub Assembly - Four Wheel Drive Option
b.	900-5905-97	1/2"-20NF Stud Only - Four Wheel Drive Option
21.	900-3938-50	1"-20UNEF Hex Slotted Nut - Four Wheel Drive Option

NOTICE Nuts, bolts, washers, and all other components can be ordered by physical description.

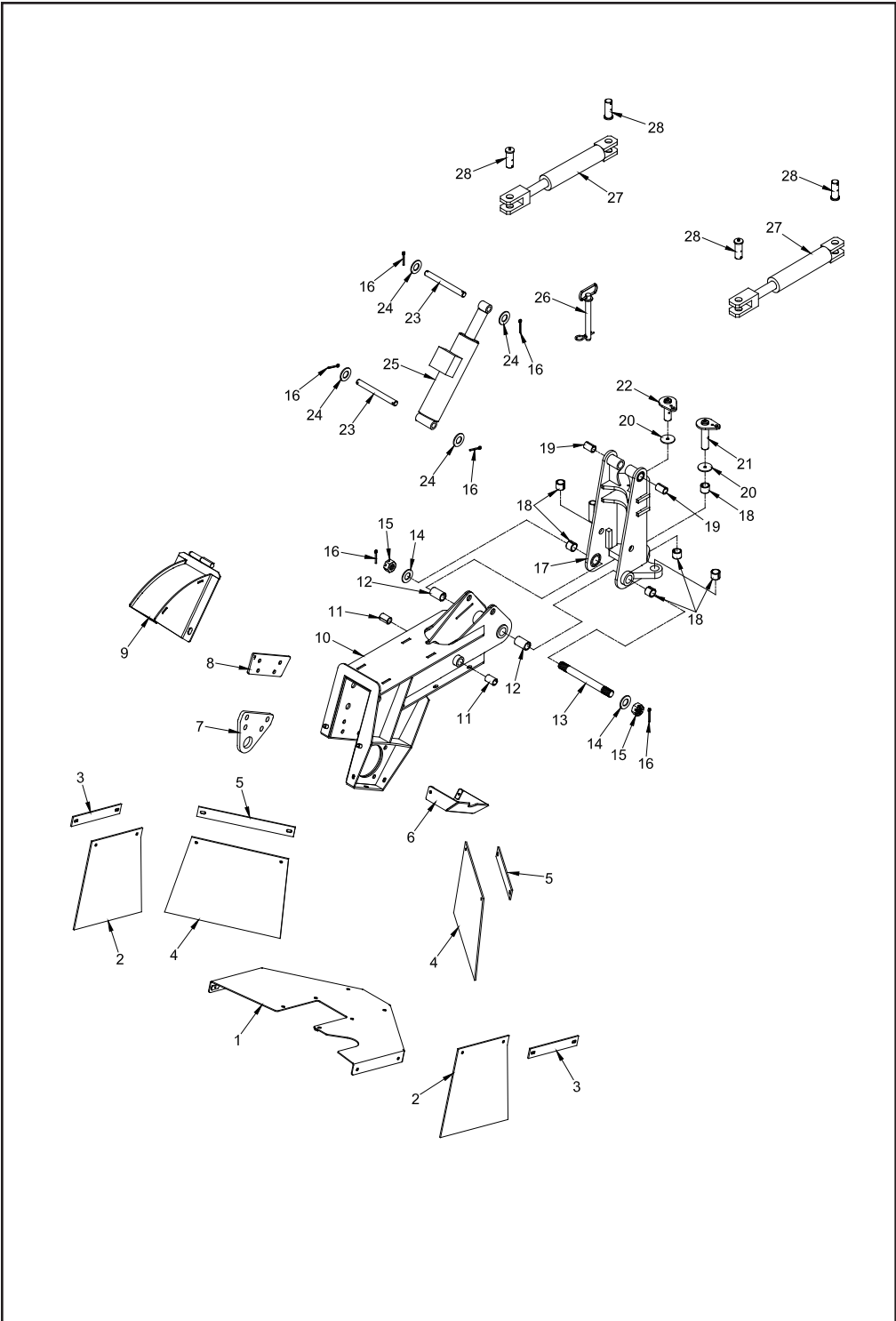

NOTICE Parts may not be exactly as shown.

LOCATION	PART NUMBER	DESCRIPTION
1.	203-2000-35	Chip Pan
2.	203-3002-97	Split Chip Curtain
3.	203-3001-49	Chip Pan Strap - 10"
4.	203-3002-98	Split Chip Curtain
5.	203-3001-44	Chip Pan Strap - 14"
6 a.	203-2000-21	Cutter Wheel Motor Guard (Start 4/14)
b.	203-2000-57	Cutter Wheel Motor Guard (Pre 4/14)
7.	203-3002-71	Stub Shaft Brace
8.	203-3002-72	Backer Plate
9.	203-2000-20	Cutter Wheel Guard
10.	203-2000-68	Cutter Wheel Arm Assembly
11.	900-1918-00	Split Bushing - 1" OD x 3/4" ID x 1-1/2"
12.	900-1918-01	Split Bushing - 1-1/4" OD x 1" ID x 2"
13.	203-3000-46	Up / Down Main Pivot Pin
14.	900-4904-46	1" Mill Carb Washer
15.	900-4909-08	1"-8NC Slotted Hex Nut
16.	900-4911-75	3/16" x 2" Cotter Pin
17.	203-2000-01	Swing Pivot Assembly
18.	900-1902-42	Split Bushing - 1-1/4" OD x 1" ID x 1"
19.	900-1912-83	Split Bushing - 1" OD x 3/4" ID x 2"
20.	203-3000-79	Pin Retainer Washer
21.	203-2000-10	Upper Pivot Pin
22.	203-2000-09	Lower Pivot Pin
23.	203-3000-63	Cutter Wheel Lift Cylinder Pin
24.	900-4901-47	3/4" Mill Carb Washer
25.	900-3940-29	Cutter Wheel Lift Cylinder
26.	900-4917-49	Cutter Wheel Lock Pin
27.	900-3958-80	Swing Cylinder
28.	900-3934-20	Cylinder Pin - 1" x 2-7/8"

NOTICE Nuts, bolts, washers, and all other components can be ordered by physical description.

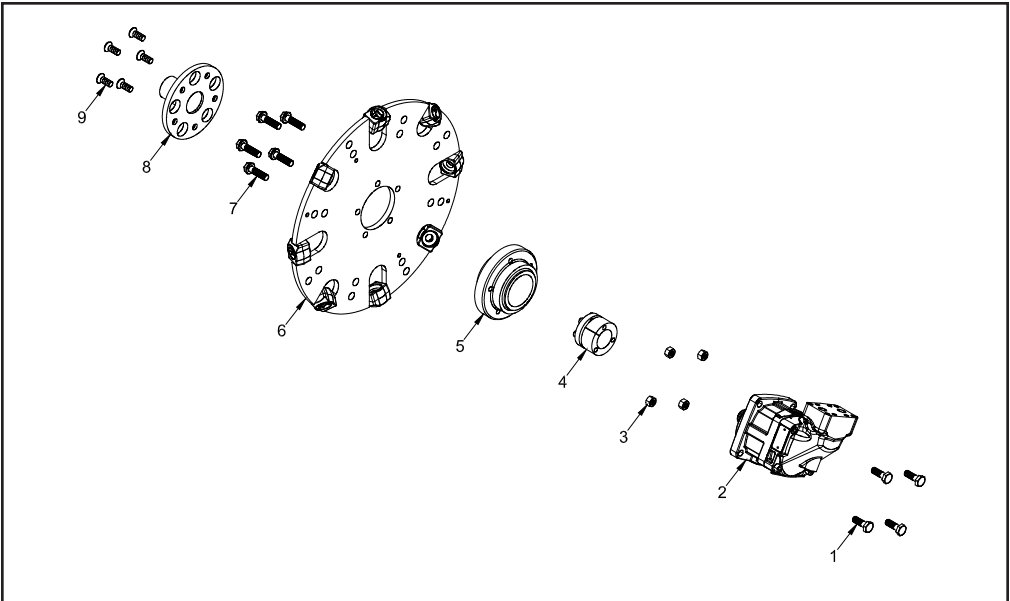

NEW RIVER "REVOLUTION" CUTTER WHEEL & TEETH

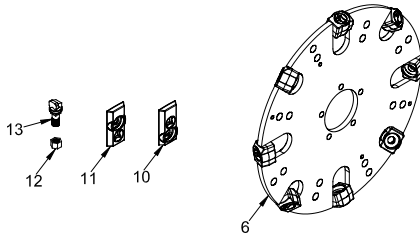

CUTTER WHEEL WITH GREEN TEETH

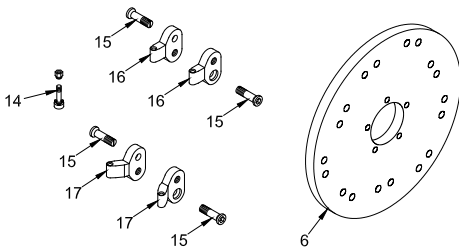

CUTTER WHEEL WITH TOMAHAWK TEETH

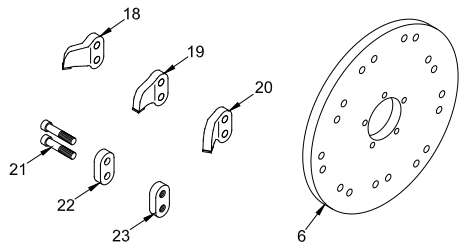

NOTICE Parts may not be exactly as shown.

LOCATION	PART NUMBER	DESCRIPTION
1.	900-4918-43	14mm x 55mm Hex Head Bolt
2 a.	900-3959-06	Cutter Wheel Motor (Start 4/14)
b.	900-3951-17	Cutter Wheel Motor (Pre 4/14)
c.	900-3943-13	Manifold Block For Cutter Wheel Motor
3.	900-4907-88	14mm Hex Nut
4 a.	900-1919-18	Taper Lock Coupler (Start 4/14)
b.	900-1917-63	Taper Lock Coupler (Pre 4/14)
5 a.	204-3002-64	Cutter Wheel Hub (Start 4/14)
b.	203-3000-74	Cutter Wheel Hub (Pre 4/14)
6 a.	900-9912-86	New River "Revolution" Cutter Wheel - Hex Teeth (Includes Teeth & Holders)
b.	900-9909-85	New River "Revolution" Cutter Wheel - Square Teeth (Includes Teeth & Holders)
c.	203-3001-05	Bandit Cutter Wheel for Green Teeth & Tomahawk Teeth
7.	900-4906-73	1/2"-13NC x 1-3/4" Hex Head Bolt
8.	203-2000-69	Stub Shaft Assembly
9.	900-4915-79	1/2"-13NC x 1" Flat Head Cap Screw
10 a.	900-9912-25	Holder With Locator Pin for Hex Teeth (8 Required)
b.	900-9909-97	Holder With Locator Pin for Square Teeth (8 Required)
11 a.	900-9912-26	Holder Without Locator Pin for Hex Teeth (8 Required)
b.	900-9909-98	Holder Without Locator Pin for Square Teeth (8 Required)
12.	900-9909-99	Tooth Nut (24 Required)
13 a.	900-9912-24	Lead Tooth (Short) for Hex Teeth (8 Required)
b.	900-9912-23	Side Tooth (Long) for Hex Teeth (16 Required)
c.	900-9909-96	Lead Tooth (Short) for Square Teeth (8 Required)
d.	900-9906-05	Side Tooth (Long) for Square Teeth (16 Required)
14 a.	900-9907-91	Green Tooth With Nut
b.	900-9907-92	Red Tooth With Nut
c.	900-9908-24	18 Red Teeth Kit - Includes Pockets & Bolts
15.	900-9907-14	Pocket Bolt
16.	900-9907-87	Straight Pocket
17.	900-9907-86	Angle Pocket
18.	900-9903-83	Tomahawk Left Tooth
19.	900-9903-82	Tomahawk Straight Tooth
20.	900-9903-84	Tomahawk Right Tooth
21.	900-9903-80	Tomahawk Pocket Bolt
22.	900-9903-85	C'Bored Mounting Block
23.	900-9903-86	Threaded Mounting Block
24.	900-9904-57	1/2" Allen Key Socket For 1/2" Drive (Not Shown)

NOTICE Nuts, bolts, washers, and all other components can be ordered by physical description.

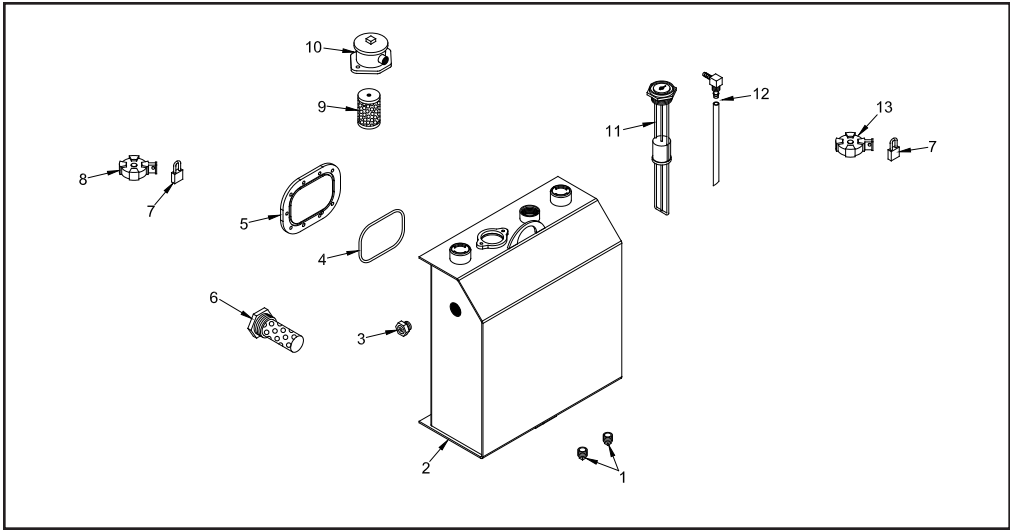

LOCATION	PART NUMBER	DESCRIPTION
1.	900-3922-60	Magnetic Drain Plug
2.	203-2000-30	Fuel & Hydraulic Tank Assembly
3.	900-3900-44	Glass Sight Gauge for Hydraulic Tank
4.	900-3950-33	Rubber O-Ring
5.	988-300134	Clean Out Door - Hydraulic tank
6.	900-3944-78	Suction Screen - SAE
7 a.	900-4912-40	Padlock With Short Shackle for Tank With Locking Cap
b.	P812	Key for Padlock (Not Shown)
8 a.	900-3941-30	Hydraulic Locking Fill Cap - Black
b.	900-3935-06	Keeper for Fuel & Hydraulic Locking Fill Cap (Not Shown)
9 a.	900-3951-32	In-Tank Hydraulic Oil Filter Only (Start 11/12)
b.	900-3938-96	In-Tank Hydraulic Oil Filter Only (Pre 11/12)
10 a.	900-3951-31	In-Tank Return Filter Assembly - Includes Filter (Start 11/12)
b.	900-3938-23	In-Tank Return Filter Assembly - Includes Filter (Pre 11/12)
11 a.	900-2903-94	Rochester Sight Gauge for Fuel Tank - 18"
b.	900-2903-55	Face for Sight Gauge Only
12 a.	900-3936-69	Suction 1/4" NPTF Elbow 3/16" Hose Barb x 1/4" Hose Barb
b.	900-3909-03	1/4" ID Drop Pipe
13 a.	900-3941-30	Fuel (Gasoline) Locking Fill Cap - Black
b.	900-3941-31	Fuel (Diesel) Locking Fill Cap - Green
c.	900-3935-06	Keeper for Fuel & Hydraulic Locking Fill Cap (Not Shown)

NOTICE Components vary with fuel type. Specify gas or diesel when ordering fuel tank components.

NOTICE Tank assemblies vary with options. Specify all options when ordering.

NOTICE Parts may not be exactly as shown.

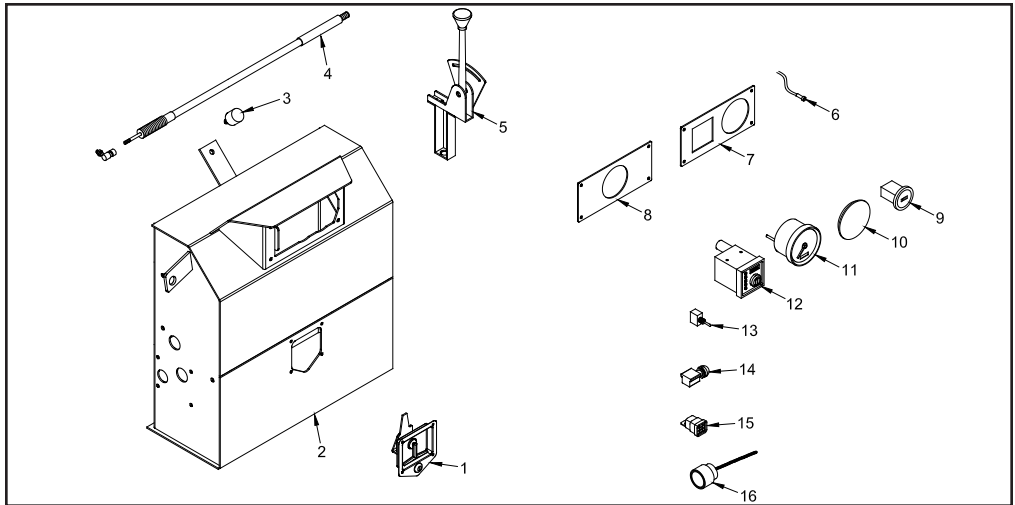

LOCATION	PART NUMBER	DESCRIPTION
1 a.	900-4908-19	"T" Handle Latch
b.	CH545	Key for "T" Handle Latch
2 a.	203-2000-41	Control Box Assembly For Swing Out Controls - Specify Engine Options
b.	203-2000-50	Control Box Ass'y For Remote Controls (2550) - Specify Engine Options
c.	203-2000-81	Control Box Ass'y For Remote Controls (2550T) - Specify Engine Options
3.	900-9905-35	Rubber Bumper Stop
4 a.	900-4916-52	Cutter Wheel Engage Handle Cable w/Diesel Engine & Swing-Out Controls - 69"
b.	900-4916-56	Cutter Wheel Engage Handle Cable w/Gas Engine & Swing-Out Controls - 74-1/2"
c.	900-4916-53	Cutter Wheel Engage Handle Cable With Remote Controls - 45"
d.	900-4913-98	Ball Socket
5.	900-4916-31	Cutter Wheel Engage Handle
6.	900-2917-10	Remote Link Light - Green
7.	203-3002-17	Panel for Tach / Hour Meter & LOFA Panel - Diesel Engine
8.	203-3002-16	Panel for Tach / Hour Meter - Gas Engine
9.	900-2903-76	Hour Meter
10.	900-2911-92	Tach / Hour Hole Plug
11 a.	900-2919-33	Tach / Hour Meter - Diesel Engine
b.	904-0002-51	Tach / Hour Meter - Gas Engine
12 a.	998-3704-36	LOFA Panel
b.	14603	Key Only
c.	900-6908-79	Extension Harness for LOFA Panel
13 a.	900-2910-47	Remote / Tether Toggle Switch
b.	900-2909-81	Rubber Boot For Toggle Switch (Not Shown)
14.	900-2916-32	Swing Out Switch
15.	900-2918-73	Sealed Relay - 12V
16.	900-2908-63	Dust Cap & Chain for Tether Jack - Radio Remote Machine
17.	900-2912-53	30 Amp Blade Type Fuse (Not Shown)
18 a.	203-8000-14	Machine Harness - Gas Engine & Swing Out Controls (Not Shown)
b.	203-8000-16	Machine Harness - Diesel Engine & Swing Out Controls (Not Shown)
c.	203-8000-15	Swing Out Harness To Selector Valve (Not Shown)
d.	203-8000-11	Machine Harness - Diesel Engine & LOR Remote Controls (Not Shown)
e.	203-8000-13	Machine Harness - Diesel Engine & Kar Tech/Omnex Remote Controls (Not Shown)
f.	203-8000-10	Machine Harness - Gas Engine & LOR Remote Controls (Not Shown)
g.	203-8000-12	Machine Harness - Gas Engine & Kar Tech/Omnex Remote Controls (Not Shown)
h.	991-8000-16	Drive Forward Valve Harness - Remote Controls (Not Shown)
i.	991-8000-17	Drive Reverse Valve Harness - Remote Controls (Not Shown)

NOTICE Parts may not be exactly as shown.

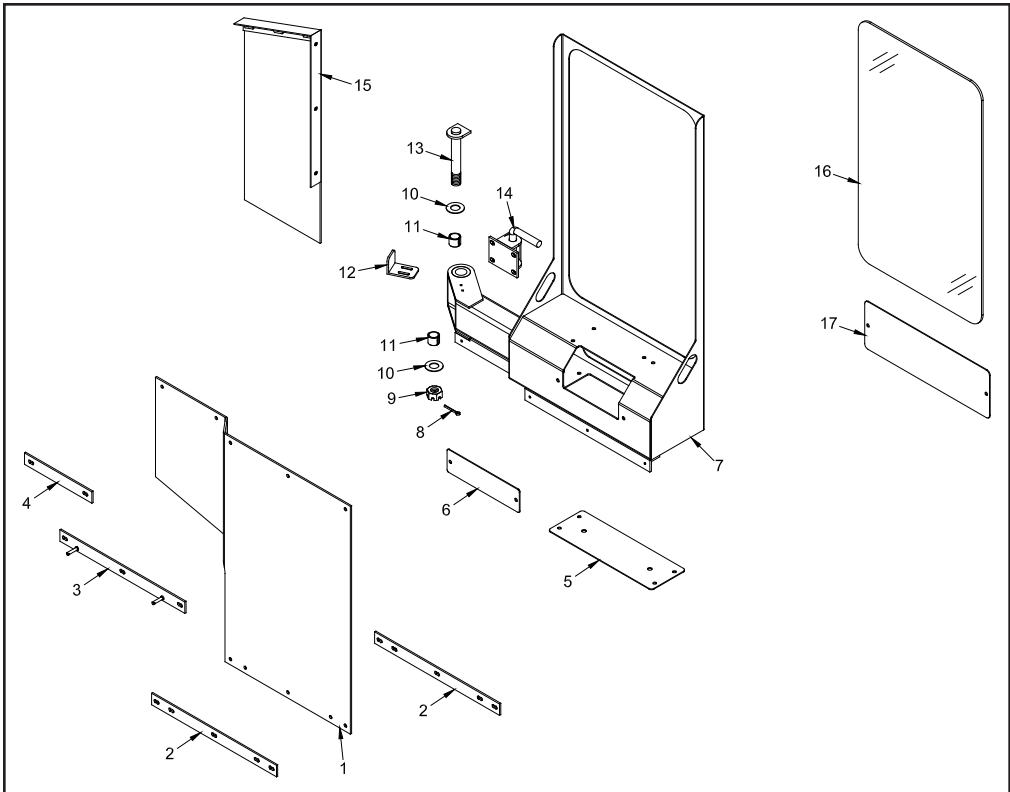

LOCATION	PART NUMBER	DESCRIPTION
1.	203-3001-73	Chip Curtain
2.	203-3001-76	Bottom Curtain Strap
3.	203-2000-43	Curtain Strap - Long
4.	203-3001-75	Curtain Strap - Short
5.	203-3001-88	Swing Out Bottom Cover
6.	203-3001-95	Swing Out Front Cover
7 a.	203-2000-39	Swing Out Assembly
b.	203-1000-21	Swing Out Complete Assembly (Includes 1-7, 11, & 14-16)
8.	900-4911-75	3/16" x 2" Cotter Pin
9.	900-4909-08	1"-8NC Slotted Hex Nut
10.	203-3002-14	Swing Out Spacer
11.	900-1902-50	Split Bushing - 1-1/4" OD x 1" ID x 1-1/2"
12.	203-3001-86	Limit Switch Engage
13.	203-2000-38	Swing Out Pin
14 a.	203-2000-42	Spring Pin Assembly
b.	900-7900-96	Rubber Cap For Spring Lock (Not Shown)
15 a.	203-2000-54	Side Window Assembly
b.	203-3002-23	Side Window Clear Vinyl Only
16 a.	996-300464	Swing Out Window
b.	900-8900-04	Window Seal (Not Shown)
17.	203-3001-64	Swing Out Arm Access Door - Large

NOTICE Parts may not be exactly as shown.



LOCATION	PART NUMBER	DESCRIPTION
1 a.	900-2926-08	Transmitter - Kar-Tech
b.	900-2926-07	Radio Remote Kit - Kar-Tech (Includes 1a & 2)
c.	900-2926-04	Cigarette Lighter Charger - Kar-Tech
d.	900-2926-05	Wall Charger - Kar-Tech
2.	900-2926-09	Receiver - Kar-Tech
3. a.	900-2926-60	Antenna - Kar-Tech
b.	999-8002-72	Loomed Antenna Cable - Kar-Tech (Not Shown)
4 a.	900-2924-88	Transmitter - LOR
b.	900-2924-86	Radio Remote Kit - LOR (Includes 4a & 5)
5.	900-2924-87	Receiver - LOR
6 a.	900-2926-44	Tether - Model 2550
b.	900-2928-82	Tether - Model 2550T
7.	900-2908-63	Cap For Tether Jack
8.	992-8000-14	12 Volt Fused Relay (Not Shown)

NOTICE Parts may not be exactly as shown.

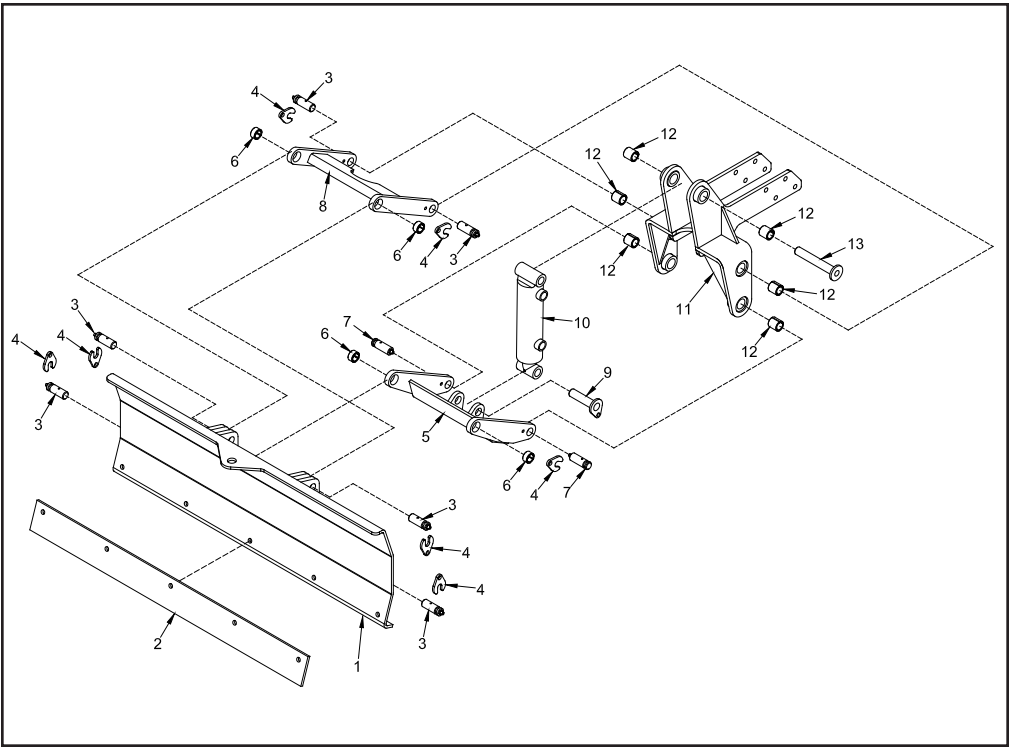

LOCATION	PART NUMBER	DESCRIPTION
1.	991-2000-36	Grading Blade Assembly (Includes #2)
2.	991-3001-40	Grading Blade Wear Bar
3.	991-3003-04	Grading Blade Arm Pin
4.	991-3003-06	Grading Blade Pin Fork
5.	991-2000-35	Grading Blade Lower Arm Assembly (Includes #6)
6.	900-1916-28	Split Bushing - 1" OD x 3/4" ID x 1/2"
7.	991-3003-05	Grading Blade Inverted Bottom Arm Pin
8.	991-2000-48	Grading Blade Upper Arm Assembly (Includes #6)
9.	991-2000-37	Lower Cylinder Pin
10.	900-3946-87	Cylinder For Grading Blade
11 a.	203-2000-29	Grading Blade Mount - Model 2550 (Includes #12)
b.	203-2000-83	Grading Blade Mount - Model 2550T (Includes #12)
12.	900-1908-38	Split Bushing - 1" OD x 3/4" ID x 1"
13.	991-2000-39	Upper Cylinder Pin

NOTICE Parts may not be exactly as shown.

<p>1.</p>  <p>In-Tank Return Filter Ass'y (Start 11/12): 900-3951-31 Filter Only (Start 11/12): 900-3951-32 In-Tank Return Filter Ass'y (Pre 11/12): 900-3938-23 Filter Only (Pre 11/12): 900-3938-96</p>	<p>2.</p>  <p>Suction Screen: 900-3944-78</p>																																								
<p>3.</p>  <p>1/4" Ball Valve: 900-3943-65</p>	<p>4.</p>  <p>Double Counter Balance: 900-3956-84 (if equipped) Counter Balance Relief Only: 900-3929-09</p>																																								
<p>5.</p> 	<table border="0"> <tr> <td>Divider / Brake Manifold Assembly (Start 11/12) (Model 2550 & 2550T With Swing Out Controls)</td> <td>900-3956-92</td> </tr> <tr> <td>Divider / Brake Manifold Assembly (Pre 11/12) (Model 2550 With Swing Out Controls)</td> <td>900-3945-13</td> </tr> <tr> <td>Brake Hand Pump (HP1)</td> <td>900-3928-25</td> </tr> <tr> <td>Brake Release Needle (NV1)</td> <td>900-3945-71</td> </tr> <tr> <td>Drive/Swing Speed Control Needle (NV2) (Start 11/12)</td> <td>900-3945-72</td> </tr> <tr> <td>Drive/Swing Speed Control Needle (NV2,NV3) (Pre 11/12)</td> <td>900-3945-72</td> </tr> <tr> <td>Brake Release Check (CV1)</td> <td>900-3945-73</td> </tr> <tr> <td>Brake Release Shuttle (LS1)</td> <td>900-3945-74</td> </tr> <tr> <td>Dual Pressure Override Check (DC1-DC3) (Start 11/12)</td> <td>900-3957-19</td> </tr> <tr> <td>Dual Pressure Override Check (DC1,DC2) (Pre 11/12)</td> <td>900-3957-19</td> </tr> <tr> <td>Drive/Swing Counter Balance (CBV1,CBV2) (Start 11/12)</td> <td>900-3929-09</td> </tr> <tr> <td>Drive/Swing Counter Balance (CBV1-CBV4) (Pre 11/12)</td> <td>900-3929-09</td> </tr> <tr> <td>Flow Divider 4WD Only (FD1)</td> <td>900-3945-79</td> </tr> <tr> <td>Cavity Plug 2WD Only (FD1)</td> <td>900-3945-77</td> </tr> <tr> <td>.030" Brake Release Orifice (ORF2)</td> <td>900-3956-99</td> </tr> <tr> <td>.094" Swing Max Speed Control Orifice (ORF4) (Pre 11/12)</td> <td>900-3957-14</td> </tr> <tr> <td>Swing Shuttle (LS2) (Start 11/12)</td> <td>900-3957-20</td> </tr> <tr> <td>Swing Pilot Valve (PD1,PD2) (Start 11/12)</td> <td>900-3957-21</td> </tr> <tr> <td>Swing Flow Control (FR1) (Start 11/12)</td> <td>900-3957-22</td> </tr> <tr> <td>Swing Tank Check (CV2) (Start 11/12)</td> <td>900-3957-23</td> </tr> </table>	Divider / Brake Manifold Assembly (Start 11/12) (Model 2550 & 2550T With Swing Out Controls)	900-3956-92	Divider / Brake Manifold Assembly (Pre 11/12) (Model 2550 With Swing Out Controls)	900-3945-13	Brake Hand Pump (HP1)	900-3928-25	Brake Release Needle (NV1)	900-3945-71	Drive/Swing Speed Control Needle (NV2) (Start 11/12)	900-3945-72	Drive/Swing Speed Control Needle (NV2,NV3) (Pre 11/12)	900-3945-72	Brake Release Check (CV1)	900-3945-73	Brake Release Shuttle (LS1)	900-3945-74	Dual Pressure Override Check (DC1-DC3) (Start 11/12)	900-3957-19	Dual Pressure Override Check (DC1,DC2) (Pre 11/12)	900-3957-19	Drive/Swing Counter Balance (CBV1,CBV2) (Start 11/12)	900-3929-09	Drive/Swing Counter Balance (CBV1-CBV4) (Pre 11/12)	900-3929-09	Flow Divider 4WD Only (FD1)	900-3945-79	Cavity Plug 2WD Only (FD1)	900-3945-77	.030" Brake Release Orifice (ORF2)	900-3956-99	.094" Swing Max Speed Control Orifice (ORF4) (Pre 11/12)	900-3957-14	Swing Shuttle (LS2) (Start 11/12)	900-3957-20	Swing Pilot Valve (PD1,PD2) (Start 11/12)	900-3957-21	Swing Flow Control (FR1) (Start 11/12)	900-3957-22	Swing Tank Check (CV2) (Start 11/12)	900-3957-23
Divider / Brake Manifold Assembly (Start 11/12) (Model 2550 & 2550T With Swing Out Controls)	900-3956-92																																								
Divider / Brake Manifold Assembly (Pre 11/12) (Model 2550 With Swing Out Controls)	900-3945-13																																								
Brake Hand Pump (HP1)	900-3928-25																																								
Brake Release Needle (NV1)	900-3945-71																																								
Drive/Swing Speed Control Needle (NV2) (Start 11/12)	900-3945-72																																								
Drive/Swing Speed Control Needle (NV2,NV3) (Pre 11/12)	900-3945-72																																								
Brake Release Check (CV1)	900-3945-73																																								
Brake Release Shuttle (LS1)	900-3945-74																																								
Dual Pressure Override Check (DC1-DC3) (Start 11/12)	900-3957-19																																								
Dual Pressure Override Check (DC1,DC2) (Pre 11/12)	900-3957-19																																								
Drive/Swing Counter Balance (CBV1,CBV2) (Start 11/12)	900-3929-09																																								
Drive/Swing Counter Balance (CBV1-CBV4) (Pre 11/12)	900-3929-09																																								
Flow Divider 4WD Only (FD1)	900-3945-79																																								
Cavity Plug 2WD Only (FD1)	900-3945-77																																								
.030" Brake Release Orifice (ORF2)	900-3956-99																																								
.094" Swing Max Speed Control Orifice (ORF4) (Pre 11/12)	900-3957-14																																								
Swing Shuttle (LS2) (Start 11/12)	900-3957-20																																								
Swing Pilot Valve (PD1,PD2) (Start 11/12)	900-3957-21																																								
Swing Flow Control (FR1) (Start 11/12)	900-3957-22																																								
Swing Tank Check (CV2) (Start 11/12)	900-3957-23																																								

NOTICE Parts may not be exactly as shown.

1.



Manual Control Valve - 4 Bank: 900-3952-74
 Manual Control Valve - 5 Bank: 900-3952-75
 Valve Handle Only: 900-3952-76

2.



Dump Valve Block Only: 900-3935-35 (Swing Out Controls)
 Solenoid Only: 900-3952-82
 Cartridge Only: 900-3952-81

3.



Remote Manifold Assembly (Model 2550)	900-3946-01
Remote Manifold Assembly (Model 2550T)	900-3960-10
Brake Hand Pump (HP1)	900-3928-25
Brake Release Needle (NV2)	900-3945-71
Brake Release Check (CV1,CV2)	900-3945-73
Brake Release Shuttle (LS1,LS2)	900-3945-74
Dual Pressure Override Check (DC1-DC3)	900-3945-75
Drive/Swing Counter Balance (CBV1,CBV2)	900-3929-09
Flow Divider 4WD Only (FD1)	900-3945-79
Cavity Plug 2WD Only (FD1)	900-3945-77
Solenoid & Cartridge (SV1-SV5)	900-3934-53
Bi-Directional Relief: Swing,Blade, Steer (CR2-CR4)	900-3954-71
Main Relief (RV2)	900-3952-66
Cutter Wheel Down Relief (RV1)	900-3952-66
Drive/Swing Flow Control (FR1,FR2)	900-3957-22
.030" Brake Release Orifice (ORF1)	900-3956-99

NOTICE Parts may not be exactly as shown.

1.



Cutter Wheel Motor: 900-3951-17

2.

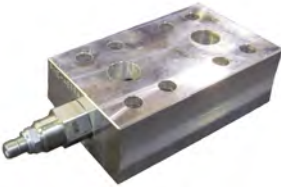

Cutter Wheel Motor Manifold Relief: 900-3955-99

Relief Only: 900-3956-04

3.

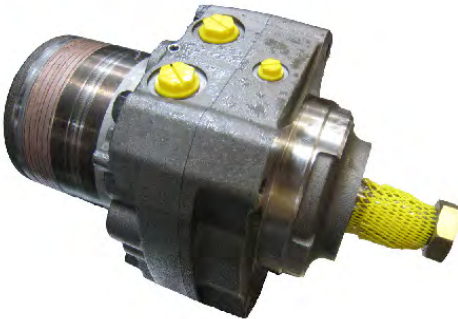

Braking Drive Motor: 900-3947-20

4.



Drive Motor Without Brake (4WD Option): 900-3947-21

NOTICE Parts may not be exactly as shown.

1.



Auxiliary Pump 2WD: 900-3956-86
Auxiliary Pump 4WD & Tracks: 900-3956-87

2.



Cutter Wheel Pump: 900-3955-97

3.



Oil Cooler: 900-3952-11

NOTICE Parts may not be exactly as shown.

1.



Swing Cylinder: 900-3958-80

2.



Steering Cylinder: 900-3937-68

3.

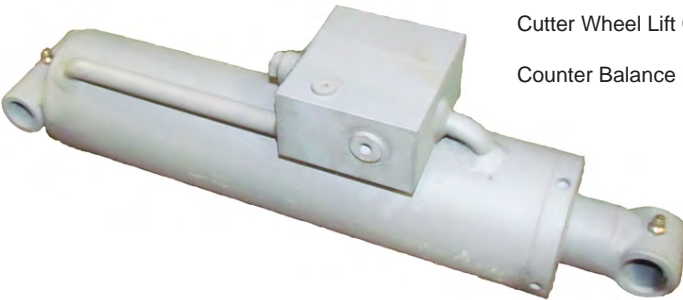

Cutter Wheel Lift Cylinder: 900-3940-29

Counter Balance Relief Only: 900-3957-08

4.



Grading Blade Cylinder: 900-3946-87

NOTICE Parts may not be exactly as shown.

SWING OUT CONTROLS

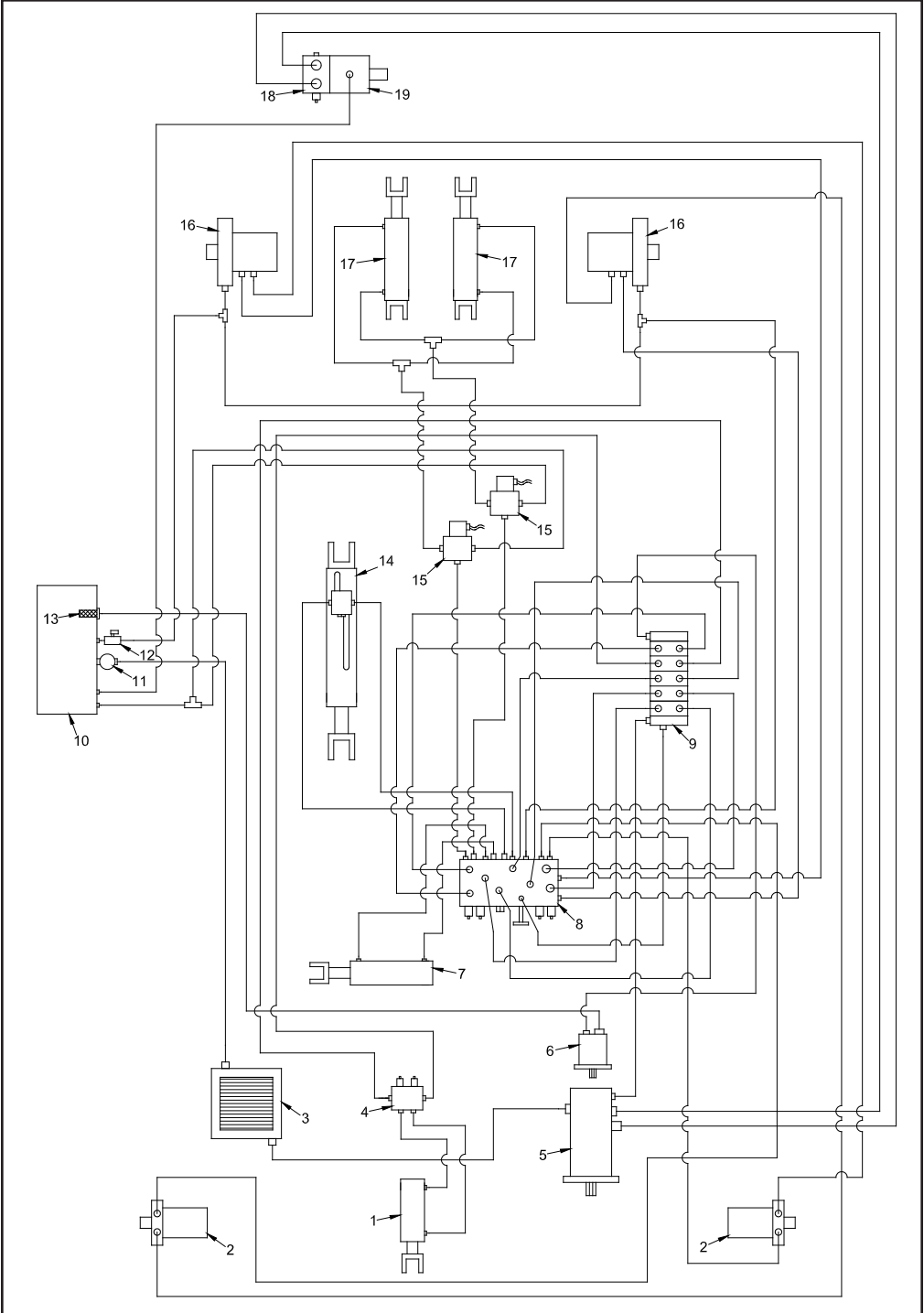

NOTICE Parts may not be exactly as shown.

SWING OUT CONTROLS

LOCATION	PART NUMBER	DESCRIPTION
1.	900-3946-87	Grading Blade Cylinder
2.	900-3947-21	Non Braking Drive Motor (if equipped with 4WD option - 2550 Only)
3.	900-3952-11	Oil Cooler
4 a.	900-3956-84	Double Counter Balance for Grading Blade (if equipped)
b.	900-3929-09	Counter Balance Relief Only
5.	900-3955-97	Cutter Wheel Pump - Splined Shaft
6 a.	900-3956-86	Auxiliary Pump
b.	900-3956-87	Auxiliary Pump With 4WD or Tracks Option
7.	900-3937-68	Steering Cylinder
8 a.	900-3956-92	Auxiliary Flow / Brake Release Manifold Assembly (Start 11/12)
b.	900-3945-13	Auxiliary Flow / Brake Release Manifold Assembly (Pre 11/12)
c.	900-3928-25	Brake Hand Pump (HP1)
d.	900-3945-71	Brake Release Needle (NV1)
e.	900-3945-72	Drive/Swing Speed Control Needle (NV2) (Start 11/12)
f.	900-3945-72	Drive/Swing Speed Control Needle (NV2,NV3) (Pre 11/12)
g.	900-3945-73	Brake Release Check (CV1)
h.	900-3945-74	Brake Release Shuttle (LS1)
i.	900-3957-19	Dual Pressure Override Check w/Thermal Relief (DC1-DC3) (Start 11/12)
j.	900-3957-19	Dual Pressure Override Check w/Thermal Relief (DC1,DC2) (Pre 11/12)
k.	900-3929-09	Drive/Swing Counter Balance (CBV1,CBV2) (Start 11/12)
l.	900-3929-09	Drive/Swing Counter Balance (CBV1-CBV4) (Pre 11/12)
m.	900-3945-79	Flow Divider 4WD Only (FD1)
n.	900-3945-77	Cavity Plug 2WD Only (FD1)
o.	900-3956-99	.030" Brake Release Orifice (ORF2)
p.	900-3957-14	.094" Swing Max Speed Control Orifice (ORF4) (Pre 11/12)
q.	900-3957-20	Swing Shuttle (LS2) (Start 11/12)
r.	900-3957-21	Swing Pilot Valve (PD1,PD2) (Start 11/12)
s.	900-3957-22	Swing Flow Control (FR1) (Start 11/12)
t.	900-3957-23	Swing Tank Check (CV2) (Start 11/12)
9 a.	900-3952-75	Manual Control Valve - 5 Bank
b.	900-3952-74	Manual Control Valve - 4 Bank
c.	900-3952-76	Valve Handle Only (Not Shown)
10.	See Page 80	Hydraulic Tank
11 a.	900-3938-96	In-Tank Hydraulic Oil Filter Only
b.	900-3938-23	In-Tank Return Filter Assembly - Includes Filter
12.	900-3943-65	1/4" Ball Valve
13.	900-3944-78	Hydraulic Tank Strainer
14 a.	900-3940-29	Cutter Wheel Lift Cylinder
b.	900-3957-08	Counter Balance Relief Only
15 a.	900-3952-82	Solenoid Only
b.	900-3952-81	Cartridge Only
c.	900-3935-35	Dump Valve Block Only
16.	900-3947-20	Braking Drive Motor
17.	900-3958-80	Swing Cylinder
18 a.	900-3955-99	Cutter Wheel Motor Manifold Relief
b.	900-3956-04	Relief Only
19.	900-3951-17	Cutter Wheel Motor

NOTICE Make sure to order components according to fitting type, fittings may vary on all components. Hydraulic components, fittings, hoses will vary depending on optional equipment. Order by physical description.

REMOTE CONTROLS

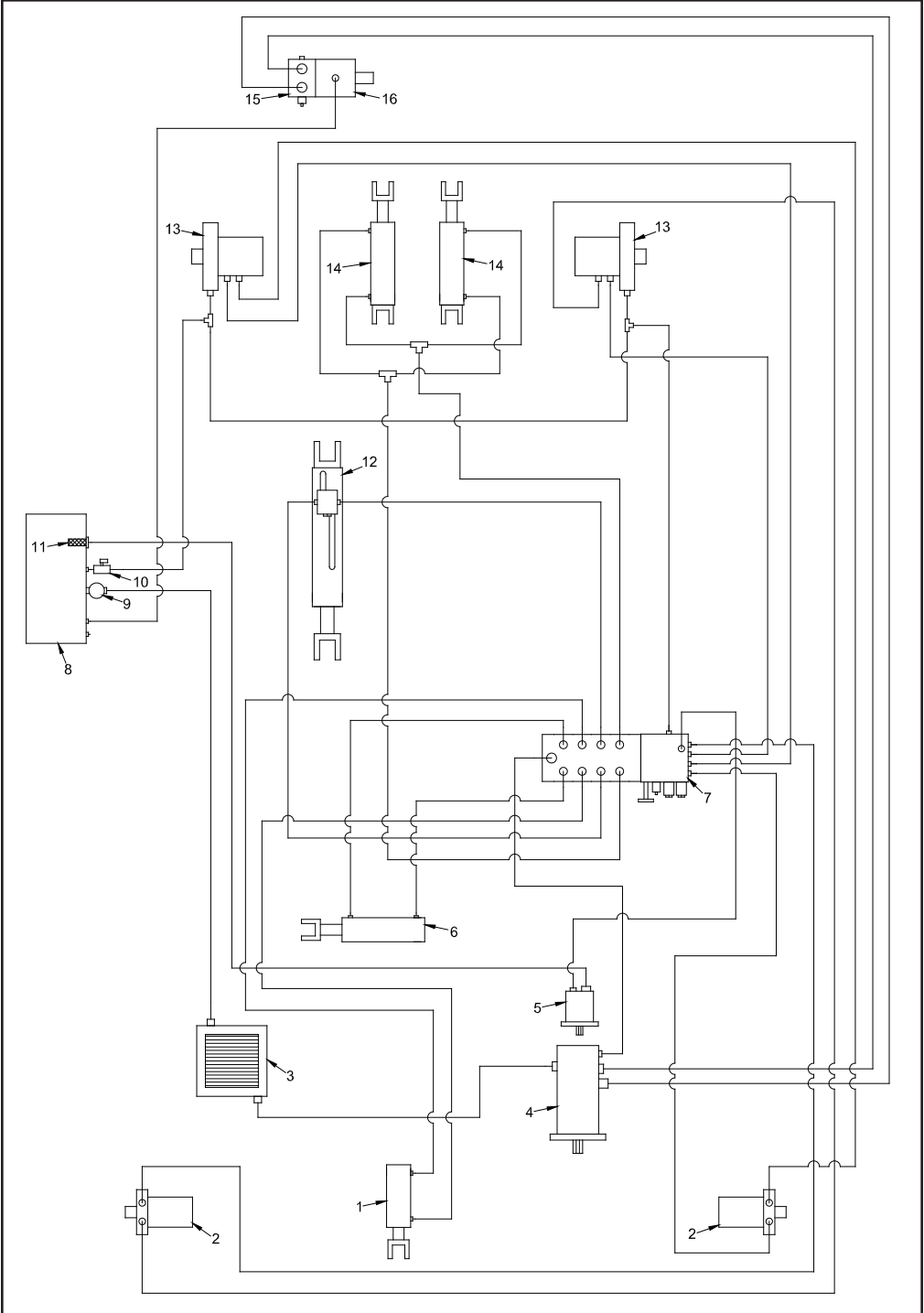

NOTICE Parts may not be exactly as shown.

REMOTE CONTROLS

LOCATION	PART NUMBER	DESCRIPTION
1.	900-3946-87	Grading Blade Cylinder
2.	900-3947-21	Non Braking Drive Motor (if equipped with 4WD option - 2550 Only)
3.	900-3952-11	Oil Cooler
4.	900-3955-97	Cutter Wheel Pump - Splined Shaft
5 a.	900-3956-86	Auxiliary Pump
b.	900-3956-87	Auxiliary Pump With 4WD or Tracks Option
6.	900-3937-68	Steering Cylinder
7 a.	900-3946-01	Remote Manifold Block Assembly (Model 2550)
b.	900-3960-10	Remote Manifold Block Assembly (Model 2550)
c.	900-3928-25	Brake Hand Pump (HP1)
d.	900-3945-71	Brake Release Needle (NV2)
e.	900-3945-73	Brake Release Check (CV1,CV2)
f.	900-3945-74	Brake Release Shuttle (LS1,LS2)
g.	900-3945-75	Dual Pressure Override Check (DC1-DC3)
h.	900-3929-09	Drive/Swing Counter Balance (CBV1,CBV2)
i.	900-3945-79	Flow Divider 4WD Only (FD1)
j.	900-3945-77	Cavity Plug 2WD Only (FD1)
k.	900-3934-53	Solenoid & Cartridge (SV1-SV5)
l.	900-3954-71	Bi-Directional Relief: Swing,Blade, Steer (CR2-CR4)
m.	900-3952-66	Main Relief (RV2)
n.	900-3952-66	Cutter Wheel Down Relief (RV1)
o.	900-3957-22	Drive/Swing Flow Control (FR1,FR2)
p.	900-3956-99	.030" Brake Release Orifice (ORF1)
8.	See Page 80	Hydraulic Tank
9 a.	900-3938-96	In-Tank Hydraulic Oil Filter Only
b.	900-3938-23	In-Tank Return Filter Assembly - Includes Filter
10.	900-3943-65	1/4" Ball Valve
11.	900-3944-78	Hydraulic Tank Strainer
12 a.	900-3940-29	Cutter Wheel Lift Cylinder
b.	900-3957-08	Counter Balance Relief Only
13.	900-3947-20	Braking Drive Motor
14.	900-3958-80	Swing Cylinder
15 a.	900-3955-99	Cutter Wheel Motor Manifold Relief
b.	900-3956-04	Relief Only
16.	900-3951-17	Cutter Wheel Motor

NOTICE Make sure to order components according to fitting type, fittings may vary on all components. Hydraulic components, fittings, hoses will vary depending on optional equipment. Order by physical description.

