



# XR1270

Operation & Safety Manual



(702) 636-2969  
(800) 497-1704

1415 W. Bonanza Rd. Las Vegas, NV 89106  
[www.XtremeManufacturing.com](http://www.XtremeManufacturing.com)



<b>Introduction . . . . .</b>	<b>3</b>	Seat Belt . . . . .	36
General . . . . .	3	Rear View Mirrors . . . . .	37
Replacement manuals . . . . .	3	Controls and Indicators . . . . .	37
Model/Serial Number Plate . . . . .	3	Travel Select Lever . . . . .	37
Orientation . . . . .	3	Gear Select Switch . . . . .	38
<b>Safety . . . . .</b>	<b>4</b>	Parking Brake Switch . . . . .	38
Safety Disclaimer . . . . .	4	Load Capacity Charts . . . . .	38
Signal Words . . . . .	4	Hydraulic Oil Temperature Indicator . . . . .	38
Safety Symbols . . . . .	4	Low Brake Pressure Indicator . . . . .	39
Employer Responsibility . . . . .	7	Rear Axle Lock Indicator . . . . .	39
Operator Responsibility . . . . .	7	Hourmeter . . . . .	39
Operator Qualifications . . . . .	7	Voltage Gauge . . . . .	39
Modifications . . . . .	7	Fuel Gauge . . . . .	40
Mounting/Dismounting . . . . .	8	Oil Gauge . . . . .	40
Work Site Safety . . . . .	8	Coolant Gauge . . . . .	40
Before Starting Forklift . . . . .	9	Light Switches . . . . .	40
Operation Safety . . . . .	10	Work Light Switch . . . . .	40
Load Safety . . . . .	13	Rear Axle Centering Indicator . . . . .	41
Attachments . . . . .	13	Steering Select Switch . . . . .	41
Shut Down Procedure . . . . .	13	Declutch Indicator . . . . .	41
Forklift Maintenance . . . . .	14	Declutch Switch . . . . .	41
<b>Dead Engine Towing . . . . .</b>	<b>16</b>	Outrigger Toggle Switches . . . . .	42
Parking Brake Release (Front Axle) . . . . .	16	Boom Control . . . . .	42
Re-activating Parking Brakes (Front Axle) . . . . .	16	Attachment Tilt Switch . . . . .	44
<b>Labels . . . . .</b>	<b>18</b>	Frame Sway Control Handle . . . . .	44
Label Legend . . . . .	18	Auxiliary Attachment Control . . . . .	45
Left Side View . . . . .	18	Optional Controls and Indicators . . . . .	45
Right Side View . . . . .	18	Two Wheel Rear (2WR) Steering Switch . . . . .	45
Front View . . . . .	19	Boom Angle Indicator . . . . .	46
Rear View . . . . .	19	Boom Extend Letters . . . . .	46
Cab View . . . . .	19	Frame Level Indicator . . . . .	46
Replacement Labels . . . . .	21	<b>Operation . . . . .</b>	<b>47</b>
<b>Features . . . . .</b>	<b>32</b>	Pre-Operation Inspection . . . . .	47
Standard Equipment . . . . .	32	Pre-Operation Inspection Checklist . . . . .	49
Optional Equipment . . . . .	32	Functional Tests . . . . .	50
<b>Specifications . . . . .</b>	<b>33</b>	Functional Test Checklist . . . . .	50
<b>Operator Cab . . . . .</b>	<b>34</b>	Operator Maintenance . . . . .	51
Ignition Switch . . . . .	34	Before Starting Forklift . . . . .	52
Accessory Outlet . . . . .	34	Starting Forklift . . . . .	52
Accelerator Pedal . . . . .	34	Normal Starting . . . . .	53
Service Brake Pedal . . . . .	35	Cold Starting . . . . .	53
Steering Wheel . . . . .	35	Jump Starting . . . . .	54
Horn Button . . . . .	35	Forklift Travel . . . . .	55
Operator Seat . . . . .	35	Steering Modes . . . . .	55
Operator Seat Controls . . . . .	35	Crab Steering . . . . .	55
Weight Suspension Lever . . . . .	35	Two Wheel Steering (2W) . . . . .	55
Lumbar Support . . . . .	36	Four Wheel Steering (4W) . . . . .	55
Fore and Aft Adjustment Lever . . . . .	36	Two Wheel Rear Steering (2WR) (Optional) . . . . .	55
Backrest Angle Adjustment Lever . . . . .	36	Maximum Fork Sweep . . . . .	55
		Starting Travel . . . . .	56
		Shifting Gears . . . . .	56
		Warning Indicators and Gauges . . . . .	56
		Stopping Travel . . . . .	57
		Changing Travel Direction . . . . .	57

Shut Down Procedure . . . . .	57
Refueling . . . . .	58
Fuel Types. . . . .	58
Attachments . . . . .	58
Attachment Disclaimer . . . . .	58
Fork Ratings . . . . .	58
Standard Carriage Operation . . . . .	59
Swing Carriage Operation . . . . .	59
Quick Attach System . . . . .	59
Attachment Connection . . . . .	59
Attachment Removal . . . . .	62
Load Handling. . . . .	63
Suspended Loads. . . . .	64
Pick Up A Load. . . . .	64
Carry A Load . . . . .	64
Place A Load . . . . .	64
Load Shift. . . . .	65
Elevating Personnel . . . . .	65
Frame Leveling . . . . .	66
Load Capacity Charts . . . . .	67
Using Load Capacity Charts . . . . .	68
Reading Load Capacity Charts. . . . .	68
Standard Carriage Load Capacity Chart. . . . .	69
<b>Preventive Maintenance . . . . .</b>	<b>70</b>
Establishing A Maintenance Program . . . . .	70
Maintenance Schedules. . . . .	70
Boom Emergency Lower Down Valve . . . . .	72
Do Not Operate – Accident Prevention Tags . . . . .	72
New or Additional Operators . . . . .	72
<b>Lockout / Tagout . . . . .</b>	<b>74</b>
Lockout/Tagout Procedure . . . . .	74
Removing Forklift From Service. . . . .	74
Returning Forklift To Service. . . . .	74
“Do Not Operate” Tags . . . . .	75

## Introduction

### General

This Operation and Safety Manual provides the information needed to safely operate the XR1270 Reach Forklift.

This manual should be considered a permanent part of the forklift and kept in the plastic, protective case located in the operator's cab.

### Notice

**BEFORE operating the forklift, read this manual completely and carefully to understand the safety instructions and the operation of controls and safety equipment. You must comply with all DANGER, WARNING, and CAUTION notices. They are for your benefit.**

### Warning

**Improper operation of this forklift could result in death or serious injury.**

**BEFORE starting the engine, do the following:**

- Read this Operation and Safety Manual.
- Read all safety Labels on the forklift.
- Clear the area of other persons.

**Learn and practice safe use of forklift controls in a safe, clear area, BEFORE you operate this forklift on a work site.**

**It is your responsibility to observe applicable laws and regulations and to follow manufacturer's instructions on forklift operation and maintenance.**

## Replacement manuals

Replacement manuals for the XR1270 Reach Forklifts can be obtained by contacting:

**Xtreme Manufacturing**  
**Phone: (800) 497-1704**

## Model/Serial Number Plate

When contacting the manufacturer, please have the forklift model and serial numbers available. The model/serial number plate is located on the left side, inside the operator's cab.

For easy reference, record the model and serial numbers in the space provided.

Model Number: \_\_\_\_\_

Serial Number: \_\_\_\_\_



Figure 1-1. Model/Serial Number Plate.

## Orientation

Right side, left side, front, and rear are directional references given from the operator's seat while facing in a forward direction.

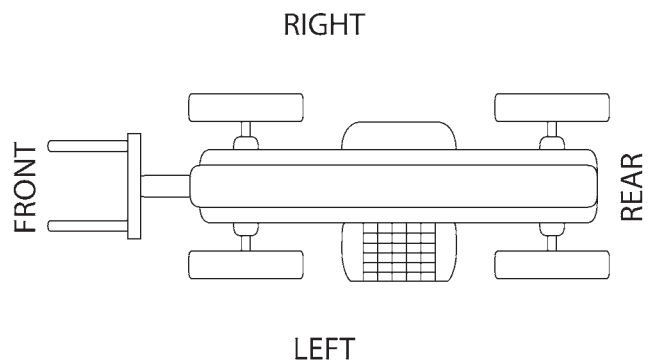

Figure 1-2. Forklift Direction Orientation.

**Safety**

**Safety Disclaimer**



Figure 2-1. Think Safety.

Xtreme Manufacturing reserves the right to make technical changes for product improvement. This manual may contain illustrations and photographs, for demonstration purposes, which slightly deviate from the actual product.

Safety information provided in this manual is a basic guide and an attempt to prevent accidents. Xtreme Manufacturing cannot anticipate every circumstance that might involve a potential hazard. Warnings in this manual and on the forklift are NOT all-inclusive.

You are responsible for safe operation of the forklift and all attachments. You must satisfy yourself that the techniques, operating procedures, work methods, or tools you use are safe; especially those not specifically mentioned by Xtreme Manufacturing.

The safety of everyone around the forklift depends significantly on your knowledge and understanding of all correct and safe operating practices and procedures. You can help prevent accidents by remaining alert and recognizing potentially hazardous situations.

Follow State and Federal health and safety rules and/or local regulations for operating and maintaining the forklift.

- This manual does not replace any laws and regulations.
- The operator is required to comply with all applicable laws and regulations.

**Signal Words**

Signal words are the word or words that call attention to the safety sign and designate a degree or level of hazard seriousness. The signal words used in this manual are DANGER, WARNING, and CAUTION.

**⚠ Danger**

**DANGER (Red)** used with the safety alert symbol indicates an imminently hazardous situation which, if not avoided, will result in death or serious injury.

**⚠ Warning**

**WARNING (Orange)** used with the safety alert symbol indicates a potentially hazardous situation which, if not avoided, could result in death or serious injury.

**⚠ Caution**

**CAUTION (Yellow)** with the safety alert symbol indicates a potentially hazardous situation which, if not avoided, could result in minor or moderate injury.

**Caution**

**CAUTION (Yellow)** used without the safety alert symbol indicates a potentially hazardous situation which, if not avoided, may result in property damage.

**Safety Symbols**

**⚠ Warning**

Safety symbols are provided to remind the operator of hazardous situations. Xtreme Manufacturing provides these symbols in an attempt to inform all operators, regardless of reading and language skills, of as many potential hazards as possible. These symbols cover many, but not all, potential dangers and hazards associated with operating the forklift.

Make safety a high priority while operating the forklift. Learn and follow all safety messages in this manual and on forklift Labels to prevent death, serious injury, or equipment damage. The following two pages include a list of some of the safety symbols that may be used on this forklift.



**General Safety Alert Symbol**



**Read Operator Manual Before Operating This Forklift**



**Read Maintenance Manual Before Working On This Forklift**



**DO NOT OPERATE! Forklift Down For Service Or Maintenance**



**Read Material Safety Data Sheets (MSDS) For Chemicals And Fluids**



**Know First Aid Instructions And/ Or Locations On Work site**



**Perform Operator Inspection Before Starting This Forklift**



**DO NOT Operate If Using Alcohol, Drugs, Or Medications**



**Personal Protective Equipment Hardhat**



**Personal Protective Equipment Gloves**



**Personal Protective Equipment Safety Shoes**



**Personal Protective Equipment Safety Glasses**



**Personal Protective Equipment Ear Protectors**



**Lead Acid Batteries Create Explosive Gases**



**No Smoking Keep Lit Cigarettes Away**



**Keep Flames And Ignition Sources Away**



**Warning! Hydraulic Oil Under Pressure**

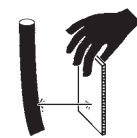

**Use A Board Or Cardboard To Check Hydraulic Leaks. DO NOT Use Your Hand!**

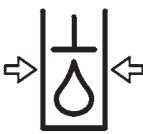

**Hydraulic System Under Pressure**



**Hot Oil! DO NOT Open Unless Cap Is Cool To Touch**



**Warning! Rotating Fan Blades Can Cut**

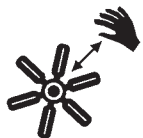

**Keep Hands A Safe Distance From Rotating Fan Blades**



**Warning! Rotating Belts Can Cut Or Entangle**

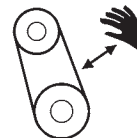

**Keep Hands A Safe Distance From Rotating Belts**



**Make Sure All Safety Labels Are Attached And Legible**



**Replace Worn And Illegible Safety Labels And Labels**



**Use Three Points of Contact When Entering and Exiting Forklift**



**DO NOT Jump While Dismounting The Forklift**



**Fasten Seat Belt**



**DO NOT Use As A Personnel Carrier**



**DO NOT Allow Riders On Forklift Frame Or Fenders**



**DO NOT Allow Riders On Or In The Operator Cab**



**DO NOT Allow Riders On Auxiliary Attachments**



**Falling Off Of Attachment Can Result In Death Or Serious Injury**



**Set Parking Brake To ON  
Engage Parking Brake**



**Set Parking Brake To OFF  
Disengage Parking Brake**



**Warning!  
Forklift Roll Away Can Cause Death Or Serious Injury**



**Warning!  
Forklift Tip Over Can Cause Death Or Serious Injury**



**DO NOT Jump!  
If Forklift Tips, Keep Seat belt ON And Brace Yourself**



**Warning!  
DO NOT Travel With Boom Raised**



**DO NOT Raise Boom While Traveling On A Slope**



**Tip Over Hazard, Especially Traveling Up A Slope Without A Load**



**Warning!  
Electrocution Can Cause Death Or Serious Injury**

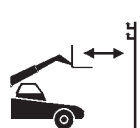

**Danger!  
Keep A Safe Distance From Electrical Lines**



**Hot Surface!  
Keep Hands Away**



**DO NOT Allow Anyone Under A Raised Load**



**Pinch Points Hands**



**Pinch Points Body**



**Warning!  
Explosion Hazard**



**DO NOT Use Ether As A Starting Aid**

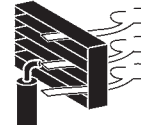

**Have Adequate Ventilation If Operating This Forklift In An Enclosed Space**



## Employer Responsibility

Under Occupational Safety and Health Administration (OSHA) rules, employers are required to train workers about hazards related to operating and maintaining the forklift. Successful completion and certification of Safety Training for Rough Terrain Forklifts is required.

Additional safety information and training resources can be obtained through these publications, organizations, and/or other appropriate sources:

- (29 CFR) Code of Federal Regulations
- (OSHA) Occupational Safety and Health Administration
- (NIOSH) National Institute for Occupational Health and Safety
- (ANSI) American National Standards Institute
- (AEM) Association of Equipment Manufacturers
- (ITSDF) Industrial Truck Standards Development Foundation

Always consult Material Safety Data Sheets (MSDS) for chemical hazards and first aid instructions for any oil or lubricant being used. MSDS should be available from the manufacturer/supplier of the fluid.

## Operator Responsibility

### Warning

Reach forklifts are potentially dangerous if proper safety procedures are not followed. Workers who operate, maintain, or work near the forklift can be at risk of roll over and run over incidents or can be crushed or caught by the forklift or its parts which could result in death or serious injury if the forklift is not properly operated or maintained.



Read the Operation and Safety Manual BEFORE operating the forklift. Follow all safety instructions and labels.

Only operate the forklift if you understand the safety instructions and warnings in all applicable manuals and technical publications. Always follow all State and Federal health and safety laws and/or local regulations.

You must have the required training, skills, and tools to perform installation, operation, maintenance, or repair procedures properly and safely. Make sure the forklift and attachments will not be damaged or made unsafe by any procedures you choose.

## Operator Qualifications

Operators must be in good physical and mental condition, with appropriate reflexes, reaction time, vision, depth perception, and hearing.

Operators must possess a valid, current driver's license as required for the work site; plus those required by applicable State, Federal, and/or local laws.

Successful completion and certification of Safety Training for Rough Terrain Forklifts is required.

- Operators must be properly instructed on how to operate the forklift and attachments.
- Operators must operate the forklift according to ALL appropriate safety regulations.
- Operator trainees must remain under constant observation and supervision of an experienced operator.

## Modifications

### Warning



Modifications to the forklift or attachments could affect forklift capacity and/or stability which could result in death or serious injury. DO NOT make modifications to the forklift or attachments without prior written approval from the manufacturer. Where such authorization is granted, capacity, operation, and maintenance instruction plates, tags, or labels shall be changed accordingly.

- Unauthorized modifications or alterations will void the warranty.
- DO NOT modify, disable, or bypass any safety devices.
- DO NOT burn or drill holes in forks or other attachments.



Structural damage, modification, or alteration, including welding or drilling, can impair and weaken the protective capability of the Rollover Protective Structure/Falling Object Protective Structure (ROPS/FOPS) and could result in death or serious injury.

- Replace the ROPS/FOPS, if it is damaged, before operating the forklift.

## Mounting/Dismounting

### ⚠ Warning

Failure to use proper safety procedures when mounting and dismounting the forklift could result in death or serious injury.

- Keep steps clear of dirt, mud, snow, ice, debris, and other hazards.



Face the forklift for mounting or dismounting. Use hand holds and steps to maintain three (3) points of contact at all times, either both hands and one foot or both feet and one hand.

- DO NOT use the controls, steering wheel, or foot pedals as hand holds or steps. Avoid accidentally engaging or disengaging a control.



DO NOT jump from the forklift. Clothing can get caught on pedals, levers, or other protruding parts. Landing on uneven surfaces could result in death or serious personal injury.

## Work Site Safety

### ⚠ Warning



Use proper safety procedures and avoid hazardous situations while operating the forklift to prevent death, serious injury, or property damage.

- Check the work site for any hazards before operating the forklift.
- Check the work surface for loose soil conditions and overhead power lines.
- Contact your local underground utility service or digging hotline to mark all underground hazards.
- Learn the location of all underground hazards at the work site, such as; gas and water pipes, electrical cables, and sewers. Underground objects could cause death or serious injury.

### ⚠ Warning

- Operate the forklift only on firm, stable surfaces. Holes, obstructions, debris, loose fill, and other work site hazards could result in death or serious injury.
- DO NOT allow bystanders in the work area.
- Avoid personnel, machinery, and vehicles in the work area.
- Know the rules for movement of people and vehicles on the work site.
- Follow work site signs and signals.
- Check boom clearance before driving under a door opening, bridge, etc.
- Slow down when approaching obstructions. Use a spotter, if necessary.
- Stop for poor visibility conditions, such as dust, smoke, fog, etc. Wait until visibility improves before continuing.

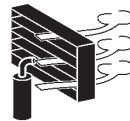

Operate the forklift in an enclosed area only if there is a ventilation system capable of routing hazardous fumes outside. Engine exhaust contains products of combustion that could cause death or serious injury.



- DO NOT operate the forklift if you are using drugs, alcohol, or any medication that might impair your judgment or ability.
- You must be 18 years of age or older to operate the forklift.
- DO NOT operate the forklift on roads. The reach forklift is not equipped for road travel.

### ⚠ Warning

#### California Proposition 65

Engine exhaust from this product contains chemicals known to the State of California to cause cancer, birth defects, and other reproductive harm.

**Warning**



Wear appropriate protective clothing. Personal protective equipment can include, but is not limited to hardhat, gloves, footwear, safety glasses or goggles, and hearing protection. Make sure clothing is snug and properly belted. **DO NOT** wear loose clothing, jewelry, watches, or anything that can catch on forklift controls, moving parts, etc. Failure to wear the proper protective clothing could result in death or serious injury.

**Before Starting Forklift**

**Warning**



Keep the Operation and Safety Manual on the forklift at all times. Contact Xtreme Manufacturing for replacement manuals.



Clearly define responsibilities and procedures for operating the forklift and all attachments. **DO NOT** proceed until you seek expert assistance from a qualified person if any doubt or question arises about the correct or safe methods for operating the forklift.



To avoid death or serious injury, carefully read and understand all instructions before operating the forklift. **DO NOT** operate, modify, repair, or maintain the forklift unless you read and understand the instructions and warnings in this and all other applicable manuals and technical publications. Follow all State and Federal health and safety laws and/or local regulations.



Consult Material Safety Data Sheets (MSDS) for chemical hazards and first aid instructions. MSDS should be available from the manufacturer or supplier of the fluid.

**Warning**



Perform a pre-operation inspection and functional tests at the beginning of each work shift. Perform the pre-operation inspection first. **DO NOT** perform the pre-operation inspection with the engine running or hot. Contact with moving or heated parts could cause death or serious injury.



Perform the pre-operation inspection and functional tests in an open area. Inspections and functional tests may require assistance. Keep the assistant visible and a safe distance from the forklift to prevent death or serious injury.



Become familiar with all safety and hazard labels, regulations, and procedures. Make sure all proper safety and hazard labels are attached to the forklift and remain legible.



A brief description of controls, indicators, and instruments is provided as a convenience for the operator. These descriptions **DO NOT** provide complete operation instructions. Read and understand the entire manual to prevent death, serious injury, or equipment damage.



Keep fingers and feet away from moving parts or pinch points to prevent pinching or crushing. **DO NOT** allow anyone between the tires and the forklift frame while operating the forklift. Doing so can result in death or serious injury.



Always check the condition of the seat belt and mounting hardware before operating the forklift. If the seat belt or mounting hardware is defective, it may not properly restrain the operator, resulting in death or serious injury.

- **DO NOT** operate the forklift until the seat belt or mounting hardware is replaced, if worn or damaged.
- The seat belt **MUST** be worn while operating the forklift. Failure to wear the seat belt could result in death or serious injury.

## ⚠ Warning



Operators must be properly trained and qualified to operate this specific forklift. Know the location, learn the specific purpose, and demonstrate safe and proper use of all controls, instruments, indicator lights, and safety and instruction labels. Safety is your responsibility. Failure to follow these guidelines could result in death or serious injury.



To prevent death or serious injury, the operator must be seated with seat belt fastened, the travel select lever set to NEUTRAL, the Parking Brake switch ON (engaged), the service brake applied, and the area free of people and obstructions BEFORE starting the forklift.

## Operation Safety

## ⚠ Danger

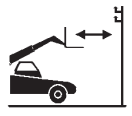

Death or serious injury by electrocution will result from contact with or inadequate clearance with energized power lines or apparatus.

- Never operate the forklift in an area where active overhead power lines, overhead or underground cables, or other power sources exist.
- Contact the appropriate power or utility company to de-energize power lines or take other suitable precautions.



Keep the forklift, attachments, and loads a safe distance from electrical power lines.

- Remain at least 10 feet (3 meters), plus an additional 0.4 inches (10 millimeters) for each 1,000 volts over 50,000 volts, from active power lines and other power sources.
- Work site operating directives and/or local or state codes might require a greater distance.
- Know the maximum height and reach of this reach forklift.

## ⚠ Warning



Use of the frame sway control with the boom raised above horizontal could cause tip over resulting in death or injury. Always use the frame sway control to level the forklift BEFORE raising the boom above horizontal. If the forklift cannot be leveled using the frame sway control, do not attempt to raise or place load. Reposition forklift or have the surface leveled.

## ⚠ Warning



To prevent death, serious injury, or property damage, the operator must be seated with seat belt fastened, arms, legs, and head completely inside the Rollover Protection Structure/Falling Object Protection Structure (ROPS/FOPS), the travel select lever in NEUTRAL, the Parking Brake switch ON (engaged), and the service brakes applied BEFORE starting the forklift.

- The seat belt MUST be worn while operating the forklift. Failure to wear the seat belt could result in death or serious injury.



DO NOT adjust the seat or seat belt while the forklift is moving. Keep both hands on the wheel while the forklift is moving to prevent loss of forklift control which could result in death or serious injury.



Never try to escape the forklift if it becomes unstable. Learn and practice these safety procedures to protect yourself from a roll over or tip over incident:

- Remain securely fastened in the seat belt.
- Keep your head, body, and limbs within the ROPS/FOPS structure.
- Brace yourself and hold on firmly.
- Lean away from the point of impact.
- Stay on the forklift and ride out the roll over or tip over.

**Warning**

**NEVER** allow passengers to ride on the forklift. **DO NOT** allow riders on the frame or operator cab. Allowing passengers to ride could result in death or serious injury. The reach forklift is designed for the safety of the operator only.



**NEVER** use crab or four wheel (4W) steering for traveling at high speeds. Use only two wheel (2W) steering for higher speed travel and slow the forklift before turning. Rapid turning while using crab or four wheel (4W) steering can cause tip over which could result in death or serious injury.



**DO NOT** travel with an elevated boom. Retract the boom fully. Lower the boom as low as practical for proper visibility. Maintain enough ground clearance for conditions. Traveling with an elevated boom can cause tip over, which could result in death or serious injury.



Allow for adequate clearance between the attachment and other objects when turning. The attachment extends beyond the front of the forklift. The operator must be aware of the maximum sweep of any attachment being used to avoid hitting personnel and other objects in the area and to prevent death, serious injury, or property damage.

**Warning**

To prevent death, serious injury, or property damage, make sure the forklift comes to a complete stop before moving the travel select lever. A sudden change in direction of travel, while carrying a load, could reduce stability and/or cause the load to shift or fall.



**DO NOT** shift through multiple gears with a single turn of the gear select lever. Allow the engine speed to slow down before shifting to the next lower gear. Improper use of the gear select lever could cause transmission damage or forklift tip over/roll over and result in death or serious injury.



Operate the forklift for maximum stability. Unstable forklifts can tip over, resulting in death, serious injury, or property damage. Keep the forklift stable by following these and other appropriate guidelines:

- Adjust speed for terrain and conditions.
- Avoid obstacles by driving around them rather than over them, when possible.
- Start, stop, travel, steer, and brake smoothly.
- Load, unload, and turn the forklift on level ground, when possible.
- Slow down for turns.
- Slow down for rough, slippery, or soft terrain.
- Use caution around steep slopes, creeks, gullies, ridges, ditches, and ravines.
- Stay away from soft edges that could collapse under the forklift.

**Warning**



Become completely familiar with the forklift before operating on slopes. The reach forklift could overturn due to sudden movement or while operating on a slope resulting in death or serious injury.



**DO NOT** raise the boom while operating on a slope. Raising the boom on a slope, even without a load, will change the center of gravity, could cause a tip over, and result in death or serious injury.

- **DO NOT** turn on a steep slope.
- **DO NOT** drive the forklift across slopes.
- Always drive the forklift straight up and down a slope (never drive diagonally up or down a slope).
- Drive the forklift forward up a slope (front of forklift facing uphill).
- Back the forklift down a slope when loaded (front of forklift facing uphill).



Follow appropriate procedures to prevent sudden changes in forklift speed that could result in death or serious injury.

- Turn the gear select lever to the lowest speed before descending a slope and before loading or unloading a trailer.
- **DO NOT** adjust the travel select lever while the forklift is moving.
- **DO NOT** coast downhill. Keep the travel select lever in the appropriate position.



**DO NOT** exit the forklift without following proper shut down procedures.



Engine fuel is flammable and can cause a fire or explosion resulting in death or serious injury. **DO NOT** smoke while refueling and keep sparks and open flames away from the forklift.

**Warning**



The reach forklift includes a Frame Sway Override switch. Improper use of the Frame Sway Override switch could result in death, serious injury, or property damage.



Make sure the forklift frame is level before raising and extending the boom. Frame swaying left or right with the boom raised is extremely dangerous and can result in death or serious injury.

- Use the frame sway control to level the forklift before raising the boom.
- Reposition the forklift if it cannot be leveled using the frame sway control.
- **DO NOT** enter or exit a tilted cab.
- Remain seated with the seat belt securely fastened while the cab is tilted.
- Keep personnel at least 30 feet (9.14 meters) from a tilted forklift.



Contact with hot surfaces and the exhaust pipe after the forklift has been operated could result in serious personal injury.



Check warning indicators and gauges on the dash panel frequently during operation. If a warning indicator is illuminated or a gauge shows abnormal readings, stop the forklift, follow proper shut down procedures, tag the forklift with "Do Not Operate" tags, and have a qualified mechanic service or repair the forklift **BEFORE** placing it into service again. Ignoring warning indicators can result in death, serious injury, or property damage.

**Caution**

Release the key immediately once the motor starts. If the motor does not start, **DO NOT** crank the starter motor continuously for more than 15 seconds. Failure to release the key after the motor has started or continuous cranking can damage the starter motor.

**DO NOT** change steering modes until the forklift comes to a complete stop. Align all four (4) tires "straight-ahead," or perpendicular to the axle, before changing steering mode.

## Load Safety

 Warning

Failure to follow proper safety procedures when lifting, lowering, and traveling with a load could result in death, serious injury, or property damage.

**DO NOT** exceed forklift capacity of 12,000 pounds (5,443 kilograms). The total rated capacity of the forks being used must equal or exceed forklift capacity. Forks can break causing loss of load and possible death or serious injury.



**DO NOT** exceed the manufacturer's rated load for any auxiliary attachment. Any attempt to lift or carry loads in excess of the manufacturer's rated load may cause forklift tip over, loss of load, or structural damage which could result in death or serious injury.



Failure to keep personnel clear of the load area while the load is being raised or lowered could result in death or serious injury. **DO NOT** lift, swing, or move a load over anyone or over a forklift cab.

- Review the rated load capacity of each auxiliary attachment before performing any operation.
- Use the correct load chart and **NEVER** exceed specified weights and load centers.
- **DO NOT** exceed the manufacturer's recommended load capacity.
- **DO NOT** operate the forklift with an unsafe load distribution.
- Adjust the load as necessary, especially for nonstandard loads.
- Use caution when handling loose material that can fall into the cab.
- Remove overhanging load materials, when possible, and watch for sliding material.
- **DO NOT** reach a load over posts or other objects that can enter the cab, if tipped.
- Avoid sudden stops, starts, or turns.
- Avoid carrying a swinging load. If necessary, secure the load by attaching it to the forklift tie-downs and/or have another person assist with safely steadying the load.

## Attachments

 Warning

Improper connection of an auxiliary attachment could result in death or serious injury. Attachments not locked into place can become unstable and fall on the operator or other personnel near the forklift.

- Make sure attachment locking devices are always in place.
- **DO NOT** operate the forklift until you have positive indication that the coupler pin and lever are fully engaged.
- Hydraulic attachments have a maximum hydraulic pressure rating. Failure to make sure the attachment is equipped with a pressure reducing valve, or is rated to be equal or greater than 4,000 psi (276 bar), which is the maximum pressure of the forklift auxiliary hydraulic system at the quick-disconnect couplers, could result in death or serious injury.
- Make sure all hydraulic connections are tight (if equipped).

## Shut Down Procedure

 Warning

To prevent death or serious injury, follow these procedures before leaving the forklift cab:

- Park forklift on a firm, level surface.
- Move travel select lever to **NEUTRAL (N)**.
- Set parking brake to **ON (engaged)**.
- Lower forks and attachments to the ground.



Always engage the parking brake before leaving the forklift. The forklift can roll if the parking brake is not **ON (engaged)**, which could result in death, serious injury, or property damage.

- Turn Ignition switch to the **OFF** position.
- Remove the key.
- Unbuckle the seat belt.
- Place "Do Not Operate" tags on the Starter switch and steering wheel when maintenance or service is required.
- Block wheels when maintenance is required.

Forklift Maintenance

**Warning**

Follow the manufacturer’s instructions for proper maintenance to make sure the forklift continues to meet manufacturer’s specifications. Failure to properly maintain the forklift can result in improper performance, which could cause death, serious injury, or property damage.



Attach “Do Not Operate” tags to the Ignition switch and steering wheel before beginning any service or maintenance.

- “Do Not Operate” tags indicate the forklift should not be operated until all service or maintenance is completed.
- Keep two (2) legible “Do Not Operate” tags with the forklift at all times. “Do Not Operate” tags are provided in this manual.



Figure 2-2. Do Not Operate Tag.

- DO NOT operate the forklift and attachments if they require repairs.
- Make sure basic maintenance is completed and service problems are corrected.
- Death or serious injury can result from operating a forklift before all repairs have been made and all proper maintenance is completed.

**Warning**



Tires must have proper ballast. DO NOT replace foam-filled tires with pneumatic tires. Use of pneumatic tires will severely affect vehicle load capacity, which could result in death, serious injury, or property damage.



Check hydraulic oil lines, tubes, and hoses carefully. DO NOT use your bare hand to check for leaks. Always use a board or cardboard when checking for a hydraulic leak. Escaping hydraulic fluid under pressure, even a pinhole size leak, can penetrate body tissue, which could cause death or serious injury. If hydraulic oil is injected into your skin, a doctor familiar with this type of injury must treat it immediately.



Serious injury could result from hydraulic oil pressure or hot oil. DO NOT remove a hydraulic tank filler cap unless it is cool enough to touch with bare hands. Remove the hydraulic tank filler cap slowly to relieve pressure. Relieve all pressure in a hydraulic system before any caps, lines, fittings, or related items are disconnected or removed.



It is possible for the forklift to move suddenly when the brakes are released, which could result in death, serious injury, or property damage. To prevent sudden movement of the forklift, place wheel chocks in front of and behind wheels before the brakes are released.



If the forklift is to be towed, make sure the released brake(s) can be reapplied or the tow vehicle has the braking capacity to stop the forklift.



DO NOT use ether as a starting aid. Ether is flammable and can cause an explosion when starting the engine, which could result in death or serious injury. Follow the cold starting procedures and engine manufacturer’s specifications for using a starting aid.



**Warning**

Lead-acid batteries produce flammable and potentially explosive gases. To avoid death or serious injury when checking, testing, or charging batteries:

- DO NOT use smoking materials near batteries.
- Keep arcs, sparks, and open flames away from batteries.
- Provide ventilation for flammable vapors.
- Wear proper personal protective equipment, including safety glasses.

Fluid in electric storage batteries contains sulfuric acid, which is poison and could cause severe chemical burns. Avoid all contact of fluid with eyes, skin, or clothing. Use protective gear when handling batteries. DO NOT tip a battery beyond a 45° angle in any direction.

If contact does occur, follow these First Aid suggestions:

- External contact - Flush with water.
- Eyes - Flush with water (including under the eyelids) for at least 15 minutes and get medical attention immediately. Flushing must begin immediately to avoid permanent eye tissue damage.
- Internal contact - Drink large quantities of water or milk to dilute stomach contents. Do not induce vomiting. Get medical attention immediately.

**IMPORTANT** - In case of internal contact, DO NOT give fluids that induce vomiting.

**Warning****California Proposition 65**

Battery posts, terminals, and related accessories contain lead and lead compounds, chemicals known to the State of California to cause cancer, birth defects, or other reproductive harm. Wash hands after handling these items.

**Warning**

Wear eye protection when starting a forklift with jump start cables. Improper jump start procedures could cause the battery to explode, which could result in death or serious injury.

- Never jump start a frozen battery, as it can explode. Let the battery thaw out before charging.
- NEVER jump start the forklift when travel select lever is in gear, which can cause the forklift to lurch forward or backward, and could result in death, serious injury, or property damage.
- To avoid injury or death when jump starting with another forklift, make sure the two (2) forklifts are not touching.
- DO NOT allow jump start cable ends to contact each other.
- Connect charged battery positive (+) to stalled battery positive (+).
- Connect charged battery negative (-) to stalled forklift ground. Make the connection to the stalled forklift ground last.
- Connect jump start cable to stalled forklift ground a safe distance from the battery to prevent sparks near the battery.
- Jump start only with a power source with the same voltage as the stalled forklift.
- Turn off all lights and accessories on the stalled forklift to prevent them from operating when the power source is connected.
- Electrolyte contains acid and could cause serious personal injury if it contacts the skin or eyes.

## Dead Engine Towing

### Parking Brake Release (Front Axle)

#### Warning

**Block all four wheels. Failure to do so could result in death or serious injury from vehicle roll away.**

1. Block all four wheels to prevent the vehicle from moving once the parking brake is disabled.
2. Position the towing vehicle in place. Attach any chain needed to secure the disabled vehicle.
3. Crawl under the front of the vehicle. Locate the four brake release bolts (two bolts per side) at the base of the front axle.
4. Loosen jam nuts. Loosen brake release bolts. Do not completely remove bolts. Tighten 1 full turn if bolts completely back out (repeat for each side). Tighten jam nuts.
5. Crawl out from under the vehicle and clear the area of any unnecessary personnel.
6. Crawl out from under the vehicle and clear the area of any unnecessary personnel.
7. Carefully remove the blocking from each of the four wheels and tow the vehicle to a secure location.

### Re-activating Parking Brakes (Front Axle)

#### Warning

**Block all four wheels. Failure to do so could result in death or serious injury from vehicle roll away.**

1. After you have blocked all four wheels, crawl under the front axle.
2. Loosen jam nuts. Tighten brake release bolts, until you begin to feel resistance. Tighten jam nuts (repeat for each side).
3. The parking brakes should now be re-activated and the front wheels are locked. Remove the blocks from all four wheels.
4. Verify the parking brake works.
5. Remove any warning tags from the ignition or steering wheel.

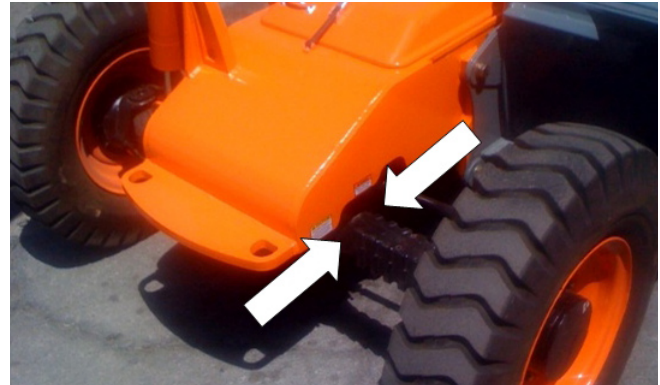

Figure 2-1. Brake Release Bolts.

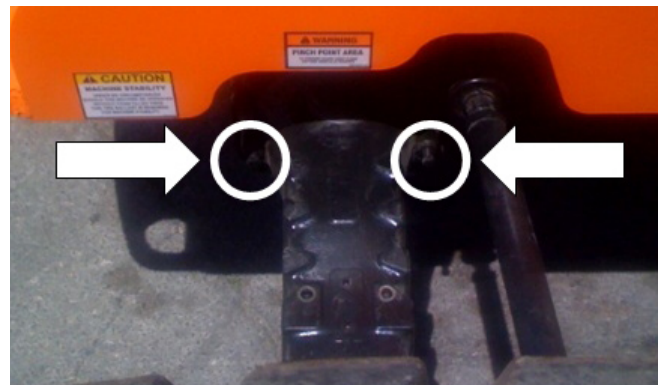

Figure 2-2. Brake Release Bolts (Cab Side).

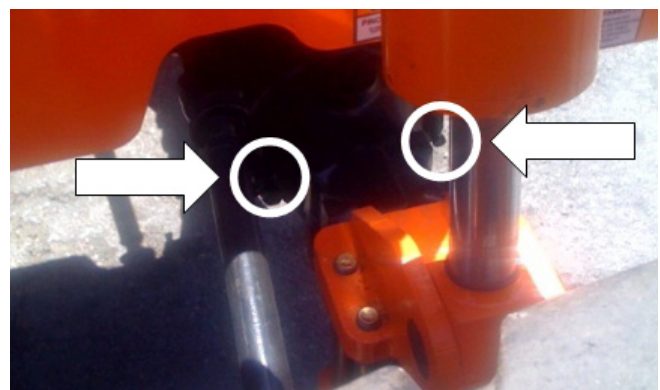

Figure 2-3. Brake Release Bolts (Tank Side).

**THIS PAGE INTENTIONALLY LEFT BLANK**

Labels

Label Legend

Left Side View

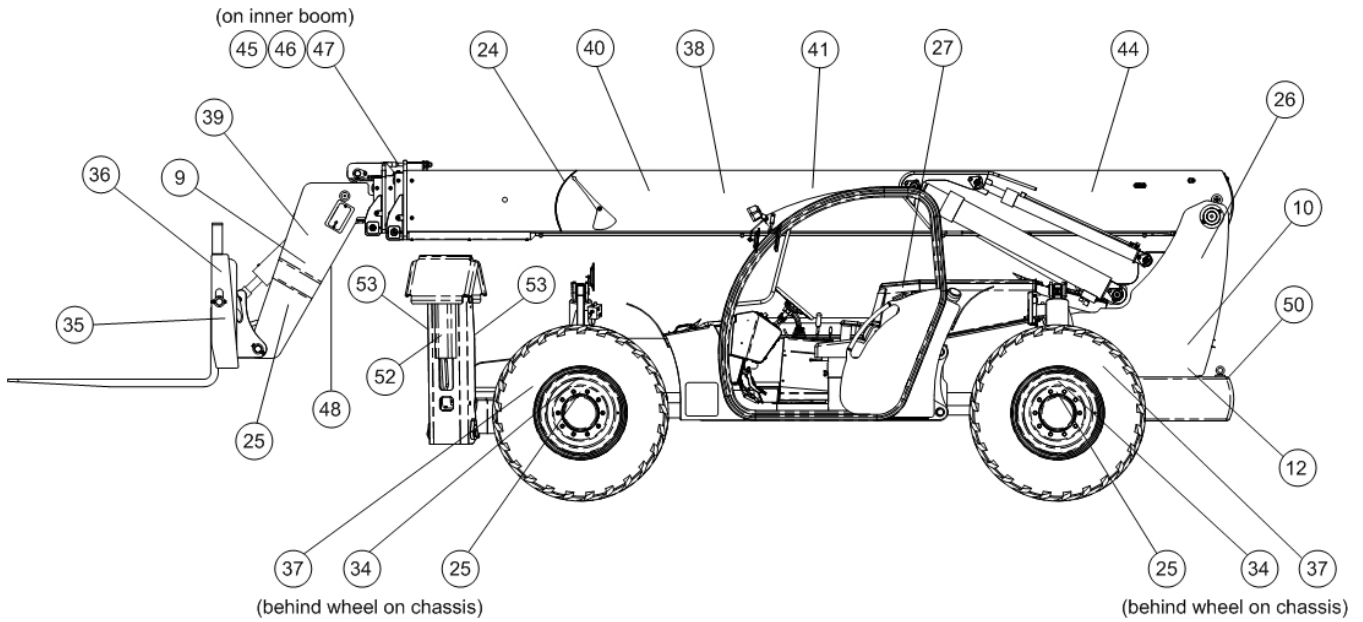

Figure 3-1. Label Legend Left Side View.

Right Side View

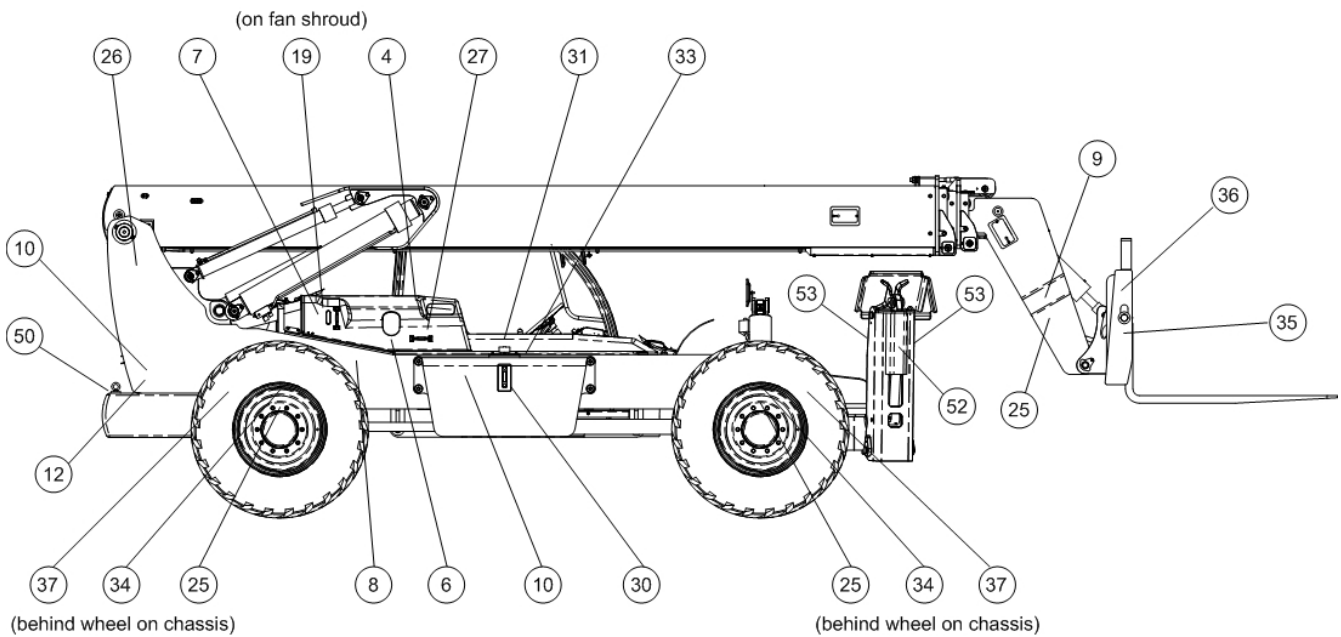

Figure 3-2. Label Legend Right Side View.

Front View

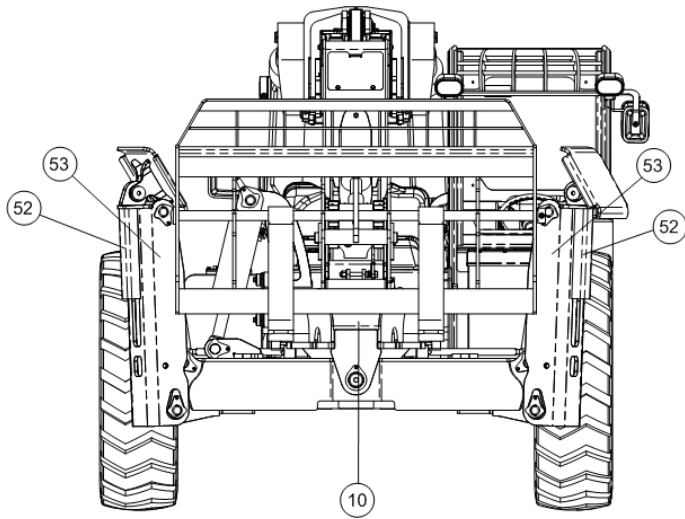

Figure 3-3. Label Legend Front View.

Rear View

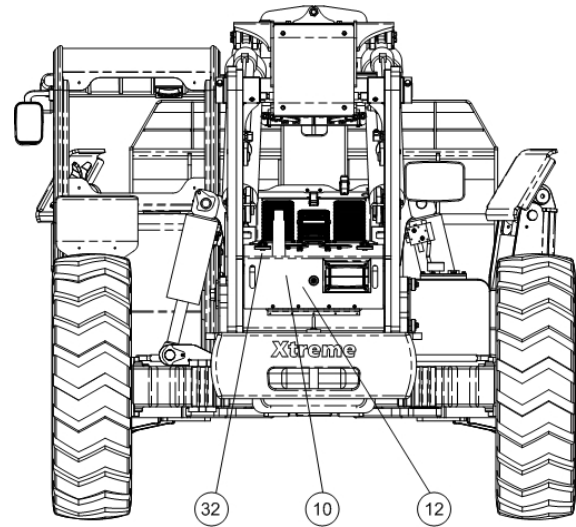

Figure 3-4. Label Legend Rear View.

Cab View

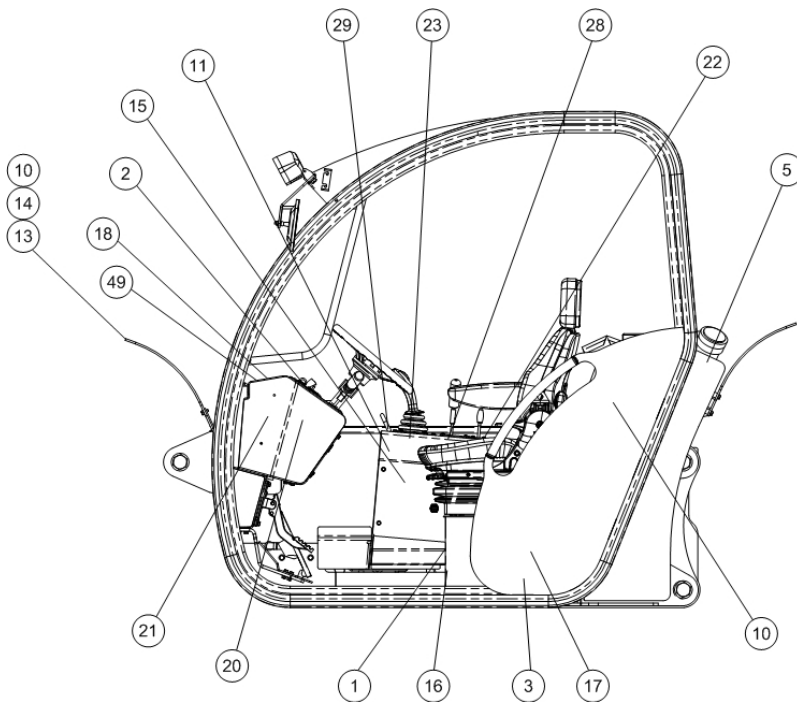

Figure 3-5. Label Legend Cab View.

**Table 1. Labels**

Item	Qty.	Part No.	Description
1	1	18008-000	Data Plate
2	1	18001-002	Dash Overlay
3	1	18010-001	Caution, Slip/Trip Hazard
4	1	18011-001	Caution, Engine Damage Hazard
5	1	18013-001	Diesel Only
6	1	18014-001	Check Engine Oil
7	1	18015-001	Check / Fill Coolant
8	1	18016-001	Caution, Burn Hazard
9	2	18017-001	Danger, Crushing Hazard
10	7	18018-001	Danger, Electrocutation Hazard
11	1	18018-002	Danger, Electrocutation Hazard
12	3	18019-001	Danger, Crushing Hazard
13	1	18020-001	Warning, Tip Over Hazard
14	1	18021-001	Danger, Crushing Hazard
15	1	18022-001	Warning, Tip Over Hazard
16	1	18023-001	Warning, Welding Modification Hazard
17	1	18025-001	Warning, Falling Hazard
18	1	18026-001	Warning, Unrestrained Operator Hazard
19	1	18027-001	Danger, Rotating Equipment Hazard
20	1	18031-001	Warning, Safe Operation Checklist
21	1	18032-001	Warning, Improper Use Hazard
22	1	18033-100	Auxiliary Handle Control
23	1	18347-000	Boom Handle Control
24	1	18039-000	Angle Indicator
25	6	18041-001	Warning, Pinch Point Hazard
26	3	18042-000	Xtreme Logo
27	2	18066-001	Caution, Crushing Hazard
28	1	18067-100	Frame Sway Handle
29	1	18334-001	Handle Auxiliary Controls
30	1	18069-000	Hydraulic Tank Fluid Level
31	1	18082-001	Warning, Injection Hazard
32	2	18083-001	Warning, Explosion Hazard
33	1	18086-001	Hydraulic Fluid, Use Dexron III
34	4	18090-001	Warning, Tip Over Hazard
35	2	18300-001	Warning, Falling Hazard
36	2	18312-000	Warning, Falling Hazard
37	4	18315-000	Tie Down Point
38	2	18095-000	Xtreme Logo
39	3	18044-000	Xtreme X
40	1	18096-000	Boom Swoosh Left Front
41	1	18097-000	Boom Swoosh Left Rear

Item	Qty.	Part No.	Description
42	1	18098-000	Boom Swoosh Right Front
43	1	18099-000	Boom Swoosh Right Rear
44	2	18367-000	XR1270
45	1	18056-000	Boom Lettering, A-B-C-D
46	1	18057-000	Boom Lettering, E-F
47	1	18058-000	Boom Lettering, G-H
48	1	18311-002	Boom Hook, 12K (Optional)
49	1	18331-000	Caution, Adjustable Carriage (Optional)
50	1	18332-000	Warning, Tow Capacity (Optional)
51	1	18307-001	Warning, Falling Hazard
52	1	18306-001	Danger, Crushing Hazard
53	1	18306-000	Danger, Crushing Hazard
54	1	17216-000	Load Chart, Standard Carriage OR Up
55	1	17217-000	Load Chart, Standard Carriage OR Down

**Replacement Labels**

Replacement labels can be obtained by contacting Xtreme Manufacturing at (800) 497-1704. Please have the appropriate label number available when you call.



1) 18008-000

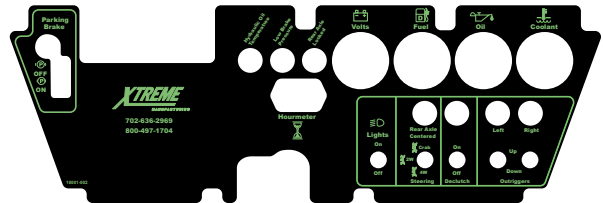

2) 18001-002



3) 18010-001



4) 18011-001



5) 18013-001



6) 18014-001



7) 18015-001



8) 18016-001



9) 18017-001

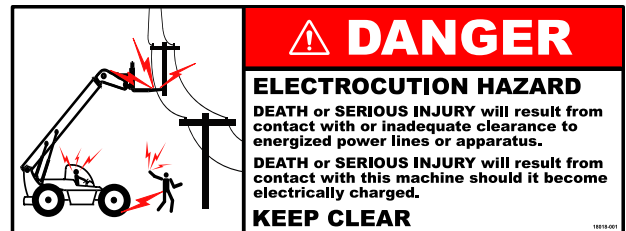

10) 18018-001

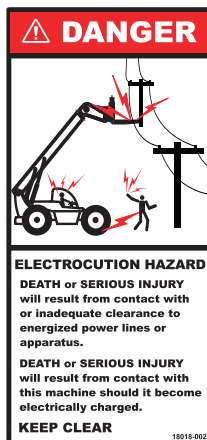

11) 18018-002



12) 18019-001





13) 18020-001

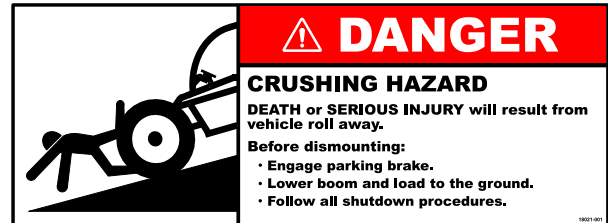

14) 18021-001

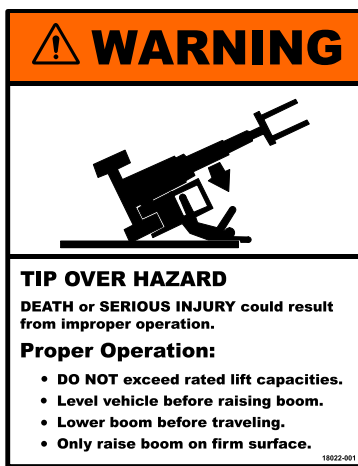

15) 18022-001



16) 18023-001



17) 18025-001



18) 18026-001

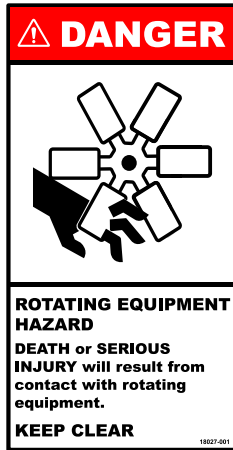

19) 18027-001

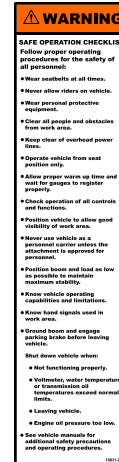

20) 18031-001

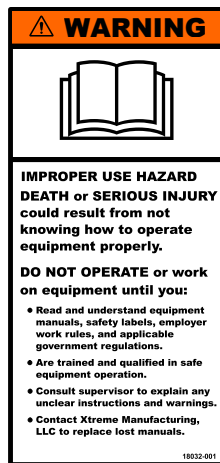

21) 18032-001

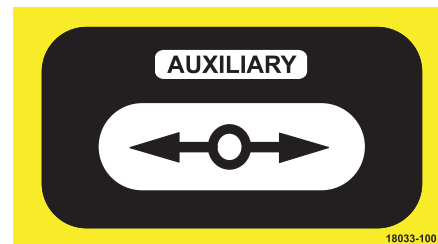

22) 18033-100

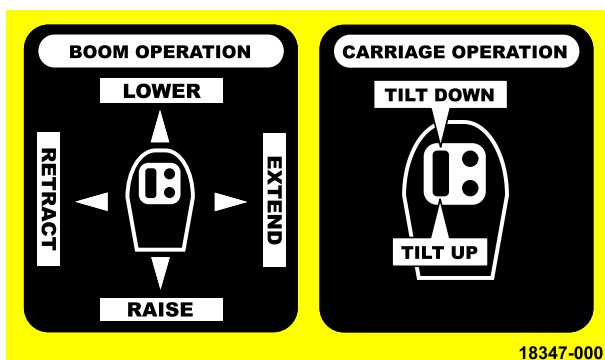

23) 18347-000

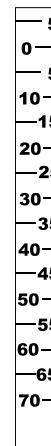

24) 18039-000



25) 18041-001



26) 18042-000



27) 18066-001

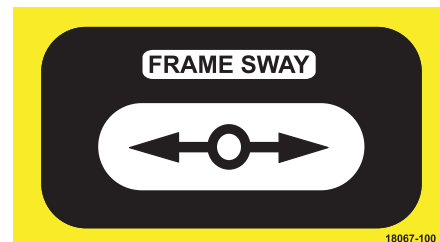

28) 18067-100

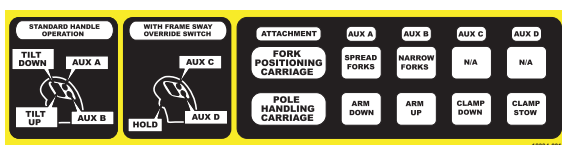

29) 18334-001

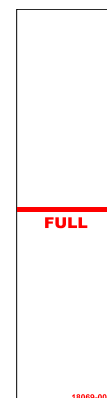

30) 18069-000

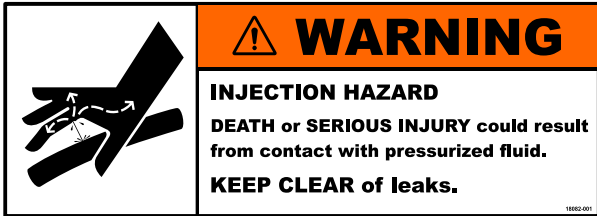

31) 18082-001



32) 18083-001



33) 18086-001

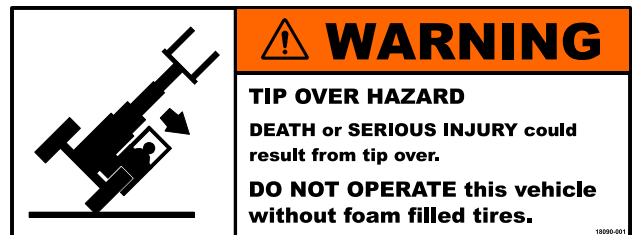

34) 18090-001

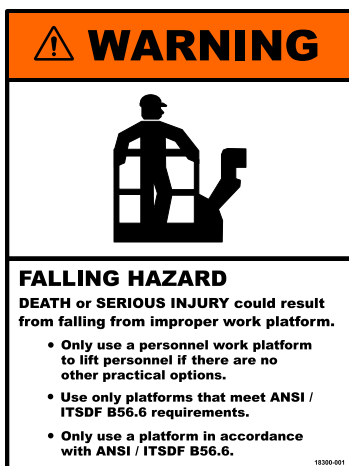

35) 18300-001



36) 18312-000

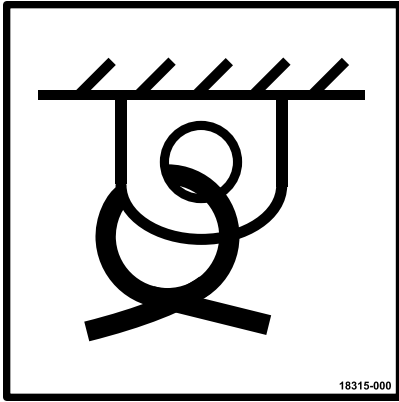

37) 18315-000



38) 18095-000

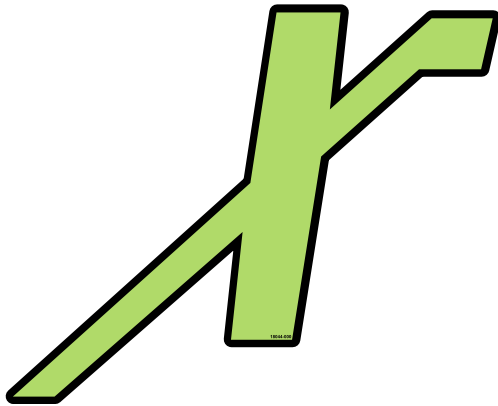

39) 18044-000

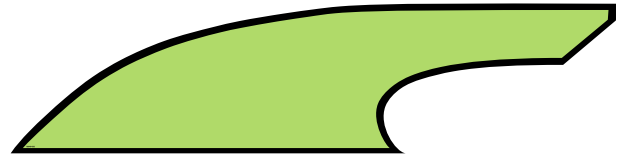

40) 18096-000



41) 18097-000



42) 18098-000



43) 18099-000



44) 18367-000



45) 18056-000



46) 18057-000



47) 18058-000

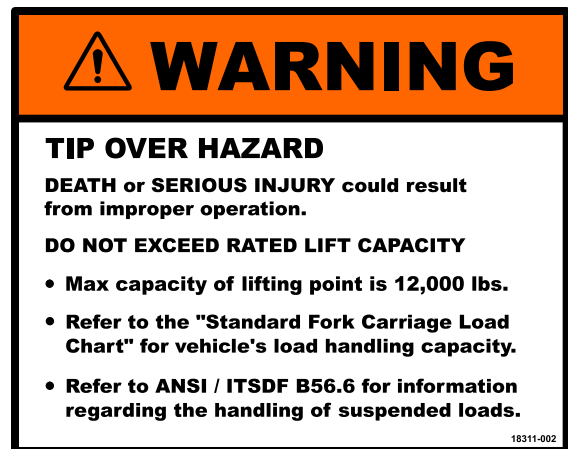

48) 18311-002

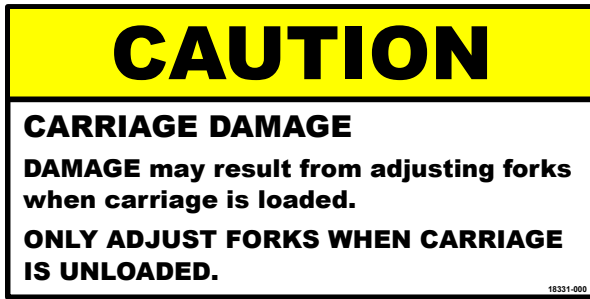

49) 18331-000

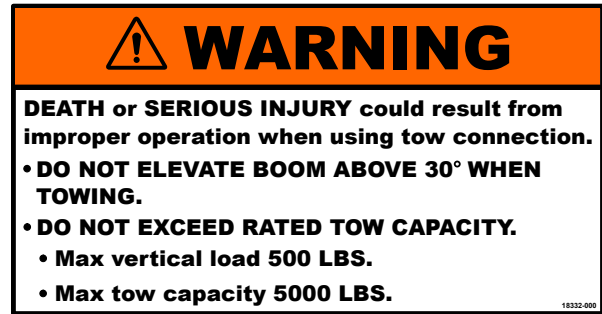

50) 18332-000



51) 18307-001



52) 18306-001



53) 18306-000

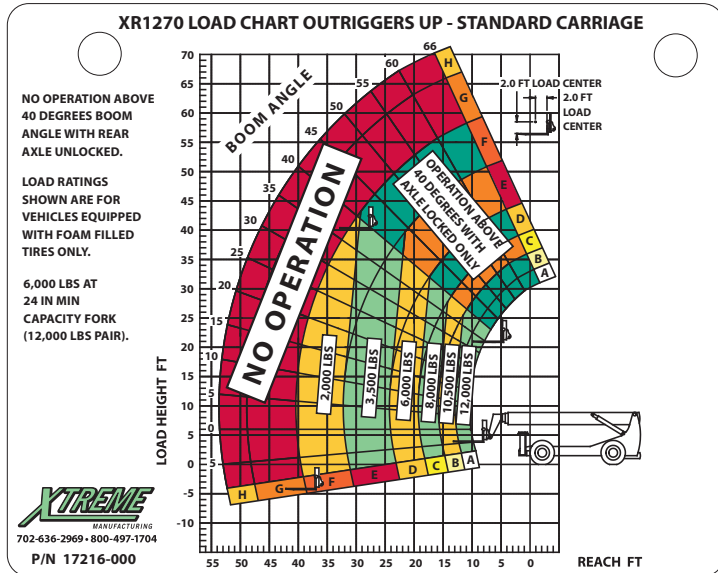

54) Load Chart OR Up

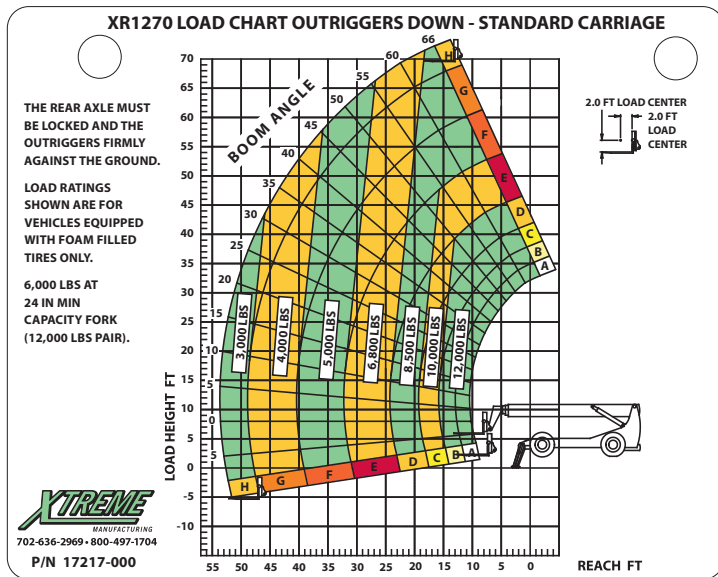

55) Load Chart OR Down



**THIS PAGE INTENTIONALLY LEFT BLANK**

## Features

### Standard Equipment

**Table 2. XR1270 Standard Equipment**

Description	Feature
Boom	Universal quick attach head
	Four (4) section boom
	Boom equipped with heavy-duty rollers, for longer life and less maintenance
Chassis	Rear axle stabilization
	1-1/4 inch main frame plate
	Sealed pivot pins for extended service periods
	High boom mount design
	Sliding engine/transmission cowling
	Low mounted central engine drive train
	Cab
Lights (front and rear)	
12 Volt electrical system	
Fuel level, engine coolant temperature, and oil pressure gauges	
Easy access drop down electrical panel	
12 Volt accessory power outlet	
Brake oil pressure, parking brake axle lock, rear wheel alignment, and declutch indicator lights	
Electric horn and backup alarm	
Declutch switch	
Rear view mirrors	
Adjustable suspension seat with seat belt	
360° panoramic visibility	
Boom angle and frame level indicator	
Deluxe suspension seat	
Tires	Foam-filled
Hydraulics	Auxiliary hydraulic circuit with quick attach
	Attachment tilt switch
	Frame sway control handle
	Frame sway override switch

## Optional Equipment

**Table 3. XR1270 Optional Equipment**

Description	Feature
Options	Hydraulic side-swing carriage (with quick attach couplers)
	Heater/defroster/windshield wiper
	Limited slip differential
	Work light package
	Various carriage sizes
	Full line of attachments
	Two-wheel rear (2WR) steering

## Specifications

### XR1270 Specifications

#### Performance



Capacity . . . . . 12,000 lbs  
Lift Height . . . . . 69' 10"  
Forward Reach . . . . . 53'8"  
Frame Leveling L/R . . . . . 8°/8°  
Operating Weight . . . . . 47,300 lbs

#### Power Train



Engine . . . . . Perkins 130 hp  
Fuel Capacity . . . . . 72 gal  
Transmission . . . . . 3-Speed  
Brakes . . . . . Inboard Wet Disc  
Parking Brake . . . . . SAHR

#### Tires



Tires (Standard Eq) . . . . . Foam Filled  
17.5 x 25 E3

#### Hydraulics



GPM . . . . . 49  
PSI . . . . . 4,000  
Hydraulic Oil Capacity . . . . . 58 gal

#### Dimensions



Length to fork face. . . . . 26'5"  
Width . . . . . 102"  
Height . . . . . 8'11"  
Wheel Base . . . . . 147"  
Ground Clearance . . . . . 15"  
Turning Radius . . . . . 15'10"

#### Attachments



Standard Carriage - 72" or 96"  
+ 10° Side Tilt Carriage - 48" or 72"  
+ 45° Swing Carriage - 52" or 72"  
Pallet Forks - 2.25" X 4" X 48"  
Lumber Forks - 1.75" X 7" X 60"  
Block Forks - 2" X 2" X 48"  
Utility Bucket - 1 cu. yd.  
Concrete Bucket - 0.5 cu. yd., or 1.00 cu. yd.  
Truss Boom - 3', 12', 15'  
Wallboard/Sheet Material Handler

#### Accessories and Options



Enclosed Cab  
Limited Slip Differential  
4th Steer Mode, Rear Pivot  
A/C  
Work Light Package  
Rotating Beacon

## Operator Cab

### Warning



A brief description of controls, indicators, and instruments is provided as a convenience for the operator.

These descriptions DO NOT provide complete operation instructions. Read and understand the entire manual to prevent death, serious injury, or equipment damage.

## Ignition Switch

A key is required to operate the ignition switch.

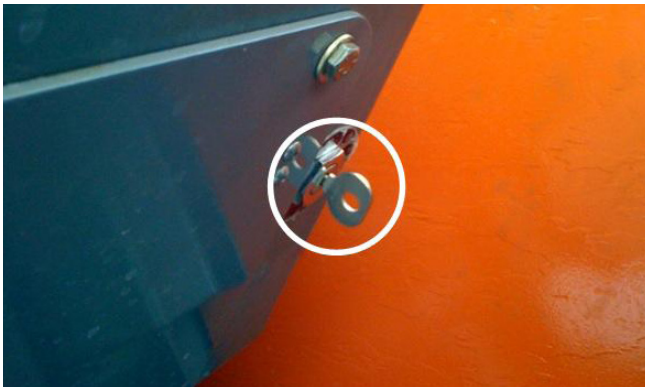

Figure 6-1. Key and Ignition Switch.

The Ignition switch has four (4) positions: OFF, RUN, PREHEAT, and START.

Table 5. Ignition Switch

Position	Purpose
OFF	Shuts down entire electrical system, except the horn and accessory outlet.
RUN	All controls and indicators are operable.
PREHEAT	Use for cold starting conditions.
START	Engages starter motor to crank engine.

**NOTE:** The PREHEAT and START positions are spring-loaded. When the key is released, the ignition switch will automatically return to the RUN position.



Figure 6-2. Ignition Switch.

## Accessory Outlet

A 12 volt accessory outlet is provided as a power source for personal items, such as a radio or cell phone.



Figure 6-3. Accessory Outlet.

## Accelerator Pedal

Press the accelerator pedal to increase engine speed. The accelerator pedal is spring-loaded to return to idle speed.

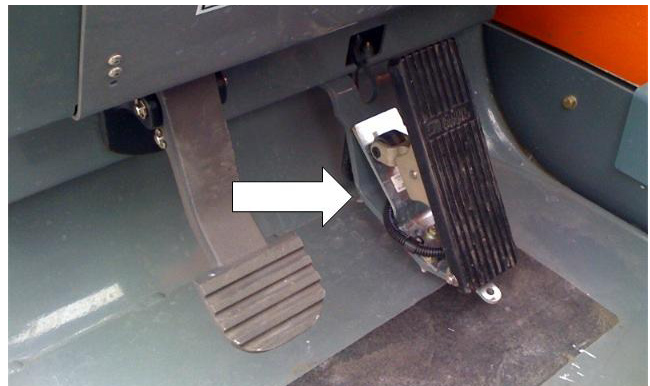

Figure 6-4. Accelerator Pedal.

## Service Brake Pedal

Press the service brake pedal to slow or stop the forklift. The service brake pedal activates the service brakes on all four (4) wheels.



Figure 6-5. Service Brake Pedal.

## Steering Wheel

Turn the steering wheel left or right to steer the forklift in the corresponding direction.



Figure 6-6. Steering Wheel.

## Horn Button

Press the horn button to sound the horn.



Figure 6-7. Horn Button.

For information call (800) 497-1704

## Operator Seat

### Operator Seat Controls

The operator seat can be adjusted four (4) ways: weight suspension, height, fore and aft, and backrest angle.



Figure 6-8. Operator Seat.

### Weight Suspension Lever

Rotate the weight suspension lever to increase or decrease the seat cushion suspension based on the weight of the operator and comfort level desired.



Figure 6-9. Weight Suspension Lever.

## Lumbar Support

The seat controls include a 4 position lumbar support knob. Rotate the lumbar support knob to raise, lower, increase, or decrease the lumbar support.



Figure 6-10. Lumbar Support.

## Fore and Aft Adjustment Lever

Pull the fore and aft adjustment lever outward from the seat to release the seat lock. Slide the seat forward or backward to a comfortable location and release the lever to lock the seat in the desired position.

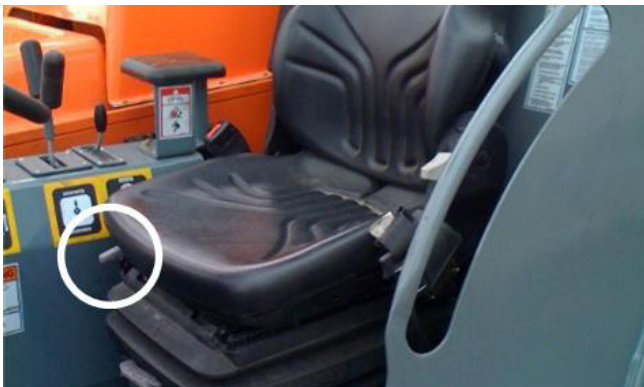

Figure 6-11. Fore and Aft Adjustment Lever.

## Backrest Angle Adjustment Lever

Pull the backrest angle adjustment lever up to release the seat backrest lock. Adjust the angle of the backrest and release the lever to lock the backrest to the desired angle.



Figure 6-12. Backrest Angle Adjustment Lever.

## Seat Belt

### ⚠ Warning



**Always check the condition of the seat belt and mounting hardware before operating the forklift. If the seat belt or mounting hardware is defective, it may not properly restrain the operator, which could result in death or serious injury.**

- **DO NOT** operate the forklift until the seat belt or mounting hardware is replaced, if worn or damaged.
- The seat belt **MUST** be worn while operating the forklift. Failure to wear the seat belt could result in death or serious injury.

The reach forklift is equipped with a standard two inch (2") wide retractable seat belt. A three inch (3") wide retractable seat belt is available where required by state and local laws and regulations.



Figure 6-13. Retractable Seat Belt.

**Warning**



**DO NOT** adjust the seat or seat belt while the forklift is moving. Keep both hands on the wheel while the forklift is moving to prevent loss of forklift control which could result in death or serious injury.

Before starting the engine, adjust the seat for position and comfort (refer to the Operator Seat section of this manual) and then adjust the seat belt as follows:

1. Grasp the free end of the seat belt (located on the left side of the seat) and make sure the belt webbing is not twisted or entangled in any portion of the seat assembly.
2. Pull the retractable seat belt across your lap. Position the seat belt as low on your body as possible.
3. Insert the latch plate into the buckle (on the right side of the seat) until a “click” is heard.
4. Make sure seat belt retracts snugly across your lap.

**Rear View Mirrors**

Two (2) adjustable rear view mirrors are provided to aid the operator’s rear vision. One (1) rear-view mirror is mounted on the upper left of the operator’s cab.



Figure 6-14. Cab-Mounted Mirror.



Figure 6-15. Frame Mounted Mirror.

For information call (800) 497-1704

**Controls and Indicators**

**Travel Select Lever**

The travel select lever has three (3) positions: FORWARD, NEUTRAL, and REVERSE, which change the direction of travel.

Table 6. Travel Select Lever

Position	Purpose
F Forward	UP Position (Away from the operator).
N Neutral	CENTER Position.
R Reverse	DOWN Position (Toward the operator).



Figure 6-16. Travel Select Lever.

The travel select lever automatically locks when it is in the NEUTRAL position. The operator must raise and move the travel select lever when changing to the FORWARD or REVERSE position.

**NOTE:** The travel select lever must be in the NEUTRAL position to start the reach forklift.

**NOTE:** The back-up alarm automatically sounds when the travel select lever is in the REVERSE position.

## Gear Select Switch

The gear select switch has a twist grip handle with three (3) positions: 1 – FIRST, 2 – SECOND, and 3 – THIRD.

**NOTE:** The reach forklift can be operated in three (3) forward and three (3) reverse gears.

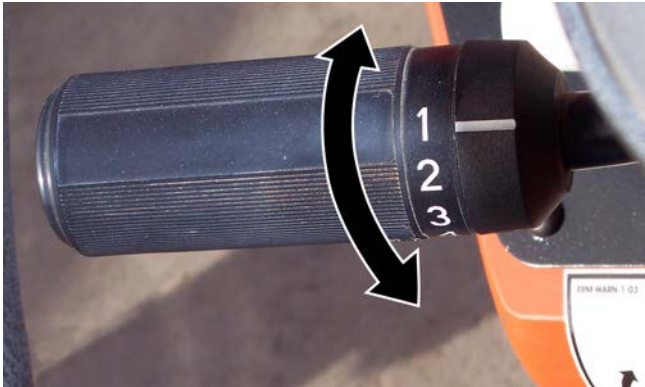

Figure 6-17. Gear Select Switch.

## Parking Brake Switch

The parking brake switch (A) has two (2) positions: ON and OFF.



Figure 6-18. Parking Brake.  
(A) Parking Brake Switch Guard. (B) Parking Brake Indicator.

Set parking brake switch (A) to ON (DOWN) to engage the parking brake and to OFF (UP) to disengage the parking brake. The parking brake indicator (B) illuminates when the parking brake is set to ON (engaged).

## Load Capacity Charts

Load capacity charts are located on the left side of the front control panel. Load capacity charts are provided to assist the operator in determining how to safely handle loads with the reach forklift, including boom angle, height, and reach.

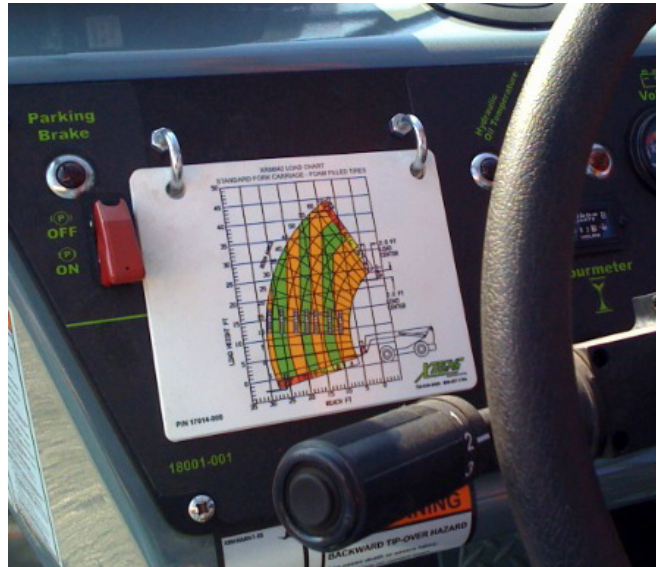

Figure 6-19. Typical Load Capacity Chart.

## Hydraulic Oil Temperature Indicator

The hydraulic oil temperature indicator illuminates when the oil temperature is above 180°F (82°C).

If the hydraulic oil temperature indicator illuminates, stop and idle the engine to allow time for cooling. If the hydraulic oil temperature indicator does not go out after five (5) minutes, stop the forklift, follow proper shut down procedures, tag the forklift with "Do Not Operate" tags, and have a qualified mechanic service or repair the forklift **BEFORE** placing it into service again.



Figure 6-20. Hydraulic Oil Temperature Indicator.



**Low Brake Pressure Indicator**

The low brake pressure indicator illuminates if the hydraulic brake oil pressure gets low.

If the low brake pressure indicator is illuminated, do not release parking brake or engage transmission until light is out. If light does not go out, stop the forklift, follow proper shut down procedures, tag the forklift with "Do Not Operate" tags, and have a qualified mechanic service or repair the forklift **BEFORE** placing it into service again.

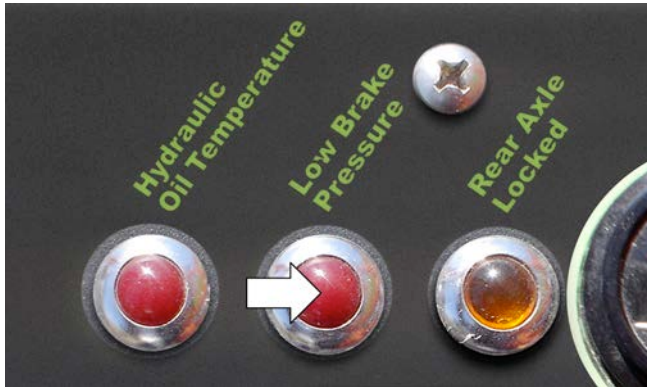

Figure 6-21. Low Brake Pressure Indicator.

**Rear Axle Lock Indicator**

The rear axle lock indicator illuminates when the forklift is in the axle lock mode. The rear axle locks when the parking brake is set to ON (engaged), or the transmission is in NEUTRAL or the service brake is applied, and when the boom is above 40°.

If the rear axle lock indicator does not illuminate, stop the forklift, follow proper shut down procedures, tag the forklift with "Do Not Operate" tags, and have a qualified mechanic service or repair the forklift **BEFORE** placing it into service again.

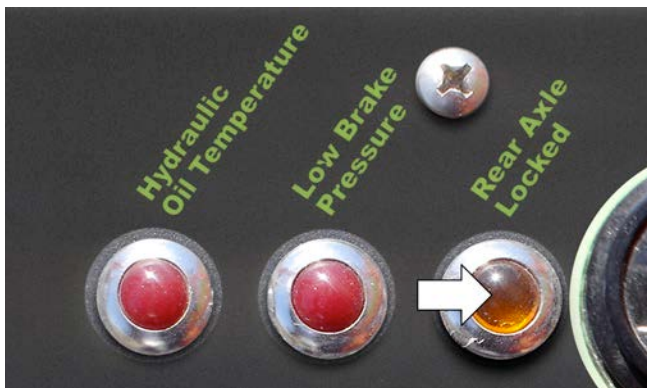

Figure 6-22. Rear Axle Lock Indicator.

**Hourmeter**

The hourmeter indicates and records engine operating hours and has a total readout of 9,999.9 hours. Use the hourmeter to establish a forklift maintenance schedule.



Figure 6-23. Hourmeter.

**Voltage Gauge**

The voltage gauge indicates the amount of charge (in volts). Normal system voltage is between 11 and 15 volts.

If the voltage gauge shows abnormal readings, stop the forklift, follow proper shut down procedures, tag the forklift with "Do Not Operate" tags, and have a qualified mechanic service or repair the forklift **BEFORE** placing it into service again.

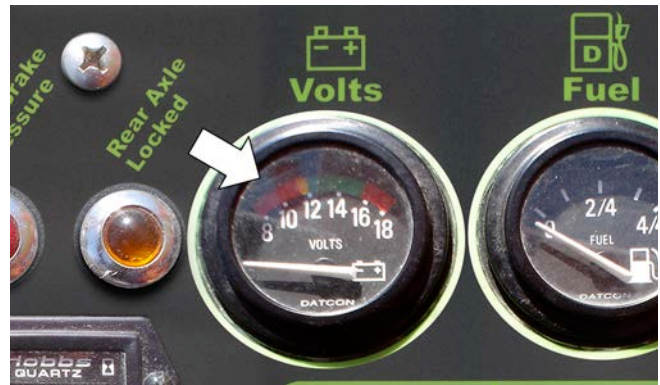

Figure 6-24. Voltage Gauge.

## Fuel Gauge

The fuel gauge indicates the quantity of fuel in the fuel tank. The total capacity of the fuel tank is 72 gallons.



Figure 6-25. Fuel Gauge.

## Oil Gauge

The oil gauge indicates the engine oil pressure. Normal engine oil pressure readings should be between 40 and 80 PSI.

If the oil gauge shows abnormal readings, stop the forklift, follow proper shut down procedures, tag the forklift with "Do Not Operate" tags, and have a qualified mechanic service or repair the forklift **BEFORE** placing it into service again.



Figure 6-26. Oil Gauge.

## Coolant Gauge

The coolant gauge indicates the temperature of the coolant in the engine cooling system. After starting the forklift, allow time for the coolant temp gauge pointer to begin to move before operating the forklift. After the engine has sufficiently warmed up, normal engine coolant temperature should read between 180 to 200°F.

If the coolant gauge shows abnormal readings, stop the

forklift, follow proper shut down procedures, tag the forklift with "Do Not Operate" tags, and have a qualified mechanic service or repair the forklift **BEFORE** placing it into service again.

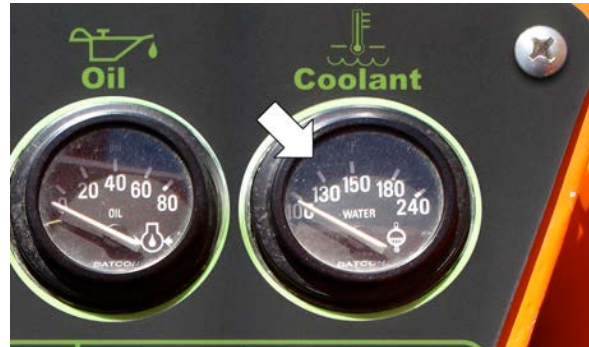

Figure 6-27. Coolant Gauge.

## Work Light Switch

The work light switch controls the two (2) front work lights. Toggle the work light switch up to turn ON and down to turn OFF the work lights.



Figure 6-28. Work Light Switch.



Figure 6-29. Front Work Lights.

**Rear Axle Centering Indicator**

The rear axle centering indicator illuminates when the rear wheels are aligned perpendicular to the rear axle. The rear wheels must be aligned perpendicular to axle in order to change the steering select switch.

If the rear axle centering indicator does not illuminate, stop the forklift, follow proper shut down procedures, tag the forklift with "Do Not Operate" tags, and have a qualified mechanic service or repair the forklift **BEFORE** placing it into service again.



Figure 6-30. Rear Axle Centering Indicator.

**Steering Select Switch**

**Warning**

**DO NOT change steering modes until the forklift slows or comes to a complete stop. Align all four (4) wheels perpendicular to the axle, before changing steering mode. Changing steering modes at higher travel speeds can make the forklift unstable, and cause a loss of control, which could result in death, serious injury, or property damage.**

The steering select switch has three (3) steering positions: Crab, Two Wheel Steering (2W), and Four Wheel Steering (4W).



Figure 6-31. Steering Select Switch.

**Declutch Indicator**

The declutch indicator illuminates when the declutch switch is set to the ON position.

If the declutch indicator does not illuminate, stop the forklift, follow proper shut down procedures, tag the forklift with "Do Not Operate" tags, and have a qualified mechanic service or repair the forklift **BEFORE** placing it into service again.



Figure 6-32. Declutch Indicator.

**Declutch Switch**

The declutch switch (in conjunction with the service brake) disengages the transmission to prevent the forklift from moving while raising or lowering a load.

- When the declutch switch is set to ON and the service brake applied, the transmission is disengaged.
- When the declutch switch is set to OFF, the transmission remains engaged when the travel select lever is set to either FORWARD or REVERSE.



Figure 6-33. Declutch Switch.

## Outrigger Toggle Switches

The outrigger toggle switches are used to lower and raise the outriggers. The outrigger indicator illuminates when the outriggers are fully extended and on the ground. Once outriggers are fully extended, the transmission is disengaged, and the frame sway is locked. Frame sway lock can be overridden with the frame sway override switch.



Figure 6-34. Outrigger Toggle Switches.



Figure 6-35. Outriggers Up.



Figure 6-36. Outriggers Down.

## Boom Control

The boom control handle has variable motions from the center position that control boom and tilt functions.

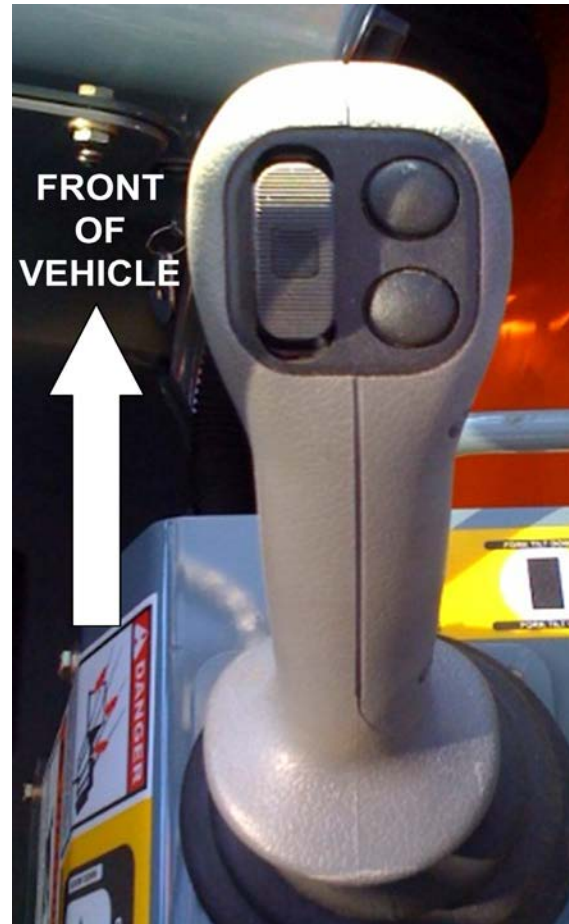

Figure 6-37. Boom Control Handle.

The boom control handle is used to raise, lower, extend, retract the boom, and tilt the carriage (or attachment).

**NOTE:** The boom control handle is a variable speed control. Function speed is proportional to handle movement. The more the handle is moved in the appropriate direction, the faster the corresponding function will occur.

**NOTE:** Increasing engine speed can increase boom lift and extend speed.

**NOTE:** Two (2) boom functions can be performed at the same time by moving the handle into the corner between two (2) functions. For example, moving the handle to the forward, left corner will lower and retract the boom at the same time.

# Front of Vehicle

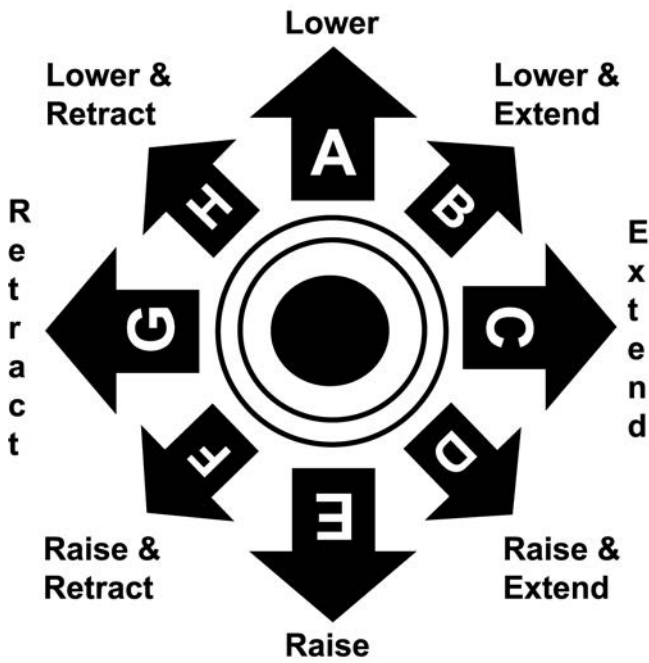

















Figure 6-38. Boom Control Handle Functions.

Table 7. Boom Control Handle Functions

<b>A</b>		
	Lower	
<b>B</b>		
	Lower	Extend
<b>C</b>		
		Extend
<b>D</b>		
	Raise	Extend
<b>E</b>		
	Raise	
<b>F</b>		
	Raise	Retract
<b>G</b>		
		Retract
<b>H</b>		
	Lower	Retract

**Attachment Tilt Switch**

The attachment tilt switch located on the top of the boom control handle controls attachment tilt functions.

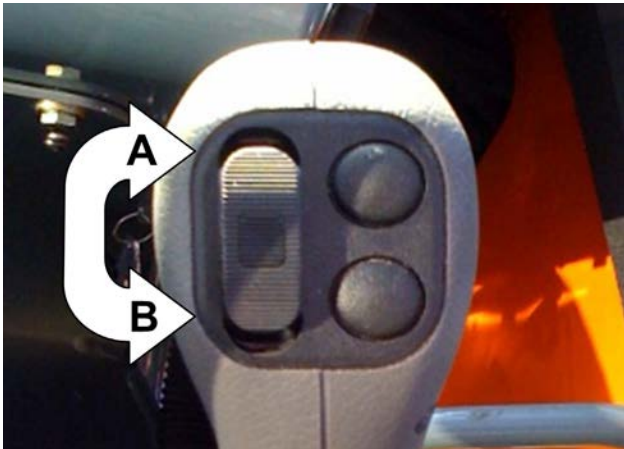

**Figure 6-39. Attachment Tilt Switch.**  
 (A) Attachment Tilt Down. (B) Attachment Tilt Up.

The attachment tilt switch:

- Controls the attachment tilt functions by rolling the switch forward and backward.
- Is a variable speed switch. Function speed is proportional to how far the switch is rolled. The more the switch is rolled in the appropriate direction, the faster the corresponding function will occur.

Table 8. Attachment Tilt Switch	
Function	Handle Action
ATTACHMENT TILT DOWN	Roll switch forward (away from the operator).
ATTACHMENT TILT UP	Roll switch backward (toward the operator).

**NOTE:** The attachment carriage will retain any set angle throughout boom raising, lowering, retracting, or extending operations.

**Frame Sway Control Handle**

The frame sway control handle installed on the side console panel, controls frame sway functions.

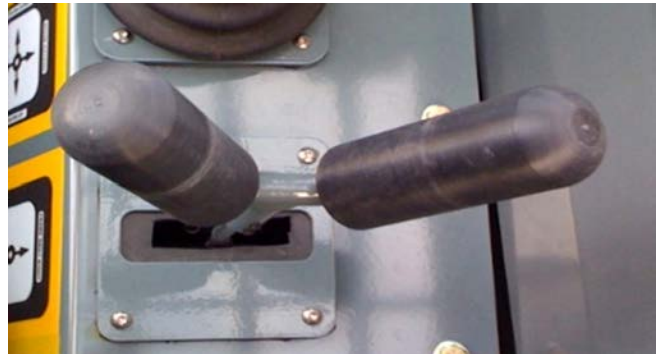

**Figure 6-40. Frame Sway Control Handle.**

The frame sway control handle:

- Controls the frame sway functions by moving the control handle left and right.
- Is a variable speed control. Function speed is proportional to control handle movement. The more the control handle is moved in the appropriate direction, the faster the corresponding function will occur.

Table 9. Frame Sway Control Handle	
Function	Control Handle Action
FRAME SWAY RIGHT	Move Control Handle RIGHT.
FRAME SWAY LEFT	Move Control Handle LEFT.

**NOTE:** Lock the frame sway by placing the travel select lever in NEUTRAL or applying the service or parking brake.

**NOTE:** Maximum frame sway is 16° overall or 8° each direction, left and right.

**Warning**



The reach forklift includes a Frame Sway Override switch. Improper use of the Frame Sway Override switch could cause death, serious injury, or property damage.

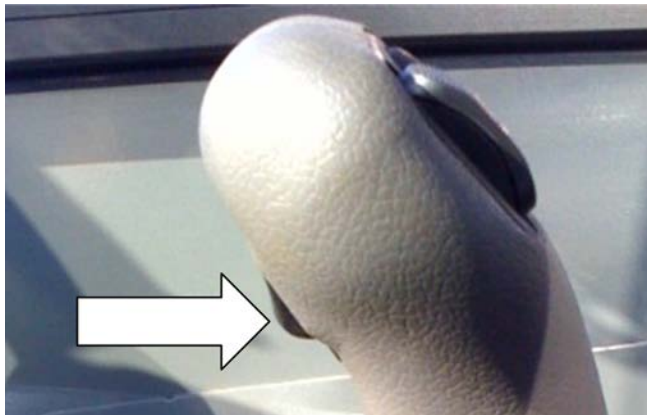

Figure 6-41. Frame Sway Override Switch.

The frame sway feature becomes locked and will not operate when the boom is raised 40° or more. Pressing the frame sway override switch (the trigger) on the control handle will override the lockout feature and allow slow frame sway.

**Auxiliary Attachment Control**

The auxiliary attachment control lever controls the functions of approved optional attachments that can be mounted to the forklift and require hydraulic supply for operation.



Figure 6-42. Auxiliary Attachment Control Lever.

**Optional Controls and Indicators**

**Two Wheel Rear (2WR) Steering Switch**

A two wheel rear (2WR) steering switch is used to engage and disengage the optional rear wheel steering feature.



Figure 6-43. Two Wheel Rear (2WR) Steering Switch.

**Warning**

**DO NOT change steering modes until the forklift slows or comes to a complete stop. Align all four (4) wheels perpendicular to the axle, before changing steering mode. Changing steering modes at higher travel speeds can make the forklift unstable, and cause a loss of control, which could result in death, serious injury, or property damage.**

## Boom Angle Indicator

The boom angle indicator is located on the left side of the boom and is visible from the operator's seat. Use the boom angle indicator to determine the boom angle when referring to load capacity charts. Refer to the Load Capacity Charts section of this manual for more information.

**NOTE:** The boom angle indicator is a plumb arrow with angular graduations from -5 to +70°.

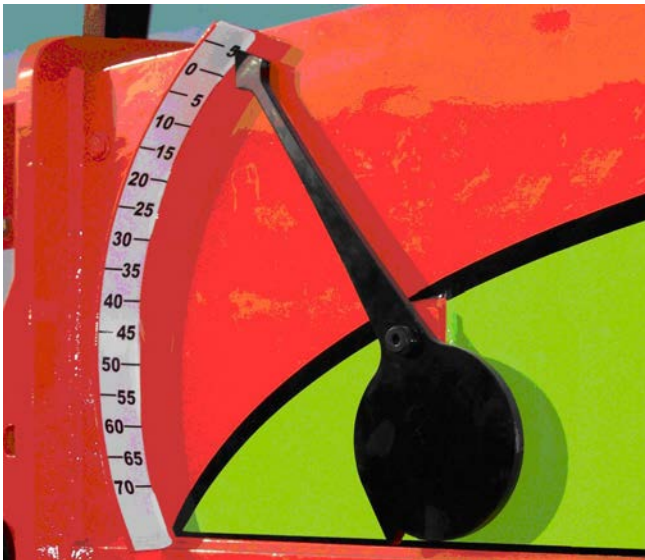

Figure 6-44. Boom Angle Indicator.

## Boom Extend Letters

As the boom is extended, boom extend letters appear on the left side of the boom visible to the operator. These letters indicate boom extension as it corresponds to the load capacity charts.

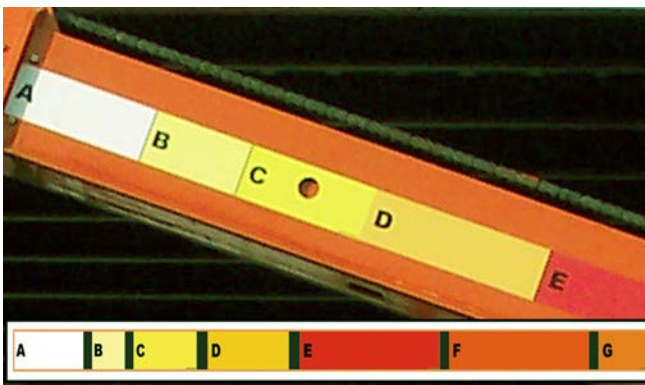

Figure 6-45. Boom Extend Letters.

## Frame Level Indicator

The frame level indicator is mounted on the upper right corner of the operator's cab. The frame level indicator allows the operator to view if the forklift has been positioned in a level condition. Always frame sway the forklift right or left until the indicator shows 0° (level).



Figure 6-46. Frame Level Indicator.



**Operation**

**Pre-Operation Inspection**

To perform the pre-operation inspection make sure the forklift is NOT running, the engine is cool, the forklift is parked on level ground, the boom is completely retracted, and the frame is level.

**NOTE:** Copy and use the Pre-Operation Inspection Checklist in this section.

**Warning**



Wear appropriate protective clothing. Personal protective equipment can include, but is not limited to hardhat, gloves, footwear, safety glasses or goggles, and hearing protection. Make sure clothing is snug and properly belted. DO NOT wear loose clothing, jewelry, watches, or anything that can catch on the forklift, such as controls and moving parts. Wearing loose clothing while operating the forklift could result in death or serious injury.



Perform a pre-operation inspection and functional tests at the beginning of each work shift. Perform the pre-operation inspection first. DO NOT perform the pre-operation inspection with the engine running or hot. Contact with moving or heated parts could cause death or serious injury.



Perform the pre-operation inspection and functional tests in an open area.



Become familiar with all safety and hazard labels, regulations, and procedures. Make sure all proper labels are attached to the forklift and remain legible.



Remove forklift from service and place "Do Not Operate" tags on the Starter switch and steering wheel if anything is found to be in need of repair or maintenance, defective, or unsafe in any way.

**Caution**



injury.

Contact with hot surfaces or the exhaust pipe after the forklift has been operated could result in minor or moderate personal

**Warning**



serious injury.

Always check the condition of the seat belt and mounting hardware before operating the forklift. If the seat belt or mounting hardware is defective, it may not properly restrain the operator, which could result in death or serious injury.

- DO NOT operate the forklift until the seat belt or mounting hardware is replaced, if worn or damaged.
- The seat belt MUST be worn while operating the forklift. Failure to wear the seat belt could result in death or serious injury.



Check hydraulic oil lines, tubes, and hoses carefully. DO NOT use your bare hand to check for potential leaks. Always use a board or cardboard when checking for a hydraulic leak. Escaping hydraulic fluid under pressure, even a pinhole size leak, can penetrate body tissue, which could cause death or serious injury. If hydraulic fluid is injected into your skin, a doctor familiar with this type of injury must treat it immediately.



Personal injury could result from hydraulic oil pressure or hot oil. DO NOT remove a hydraulic tank filler cap unless it is cool enough to touch with bare hands. Remove the hydraulic tank filler cap slowly to relieve pressure. Relieve all pressure in a hydraulic system before any caps, lines, fittings, or related items are disconnected or removed.

Never remove the radiator cap while the engine is hot. The cooling system is under pressure. Hot coolant could cause severe burns or eye injury. Wear protective clothing and safety glasses.

## ⚠ Warning



Lead-acid batteries produce flammable and potentially explosive gases. To avoid death or serious injury when checking, testing, or charging batteries:

- DO NOT use smoking materials near batteries.
- Keep arcs, sparks, and open flames away from batteries.
- Provide ventilation for flammable vapors.
- Wear proper personal protective equipment, including safety glasses.

Fluid in electric storage batteries contains sulfuric acid, which is poison and could cause severe chemical burns. Avoid all contact of fluid with eyes, skin, or clothing. Use protective gear when handling batteries. DO NOT tip a battery beyond a 45° angle in any direction.

If contact does occur, follow these First Aid suggestions:

- External contact - Flush with water.
- Eyes - Flush with water (including under the eyelids) for at least 15 minutes and get medical attention immediately. Flushing must begin immediately to avoid permanent eye tissue damage.
- Internal contact - Drink large quantities of water or milk to dilute stomach contents. Do not induce vomiting. Get medical attention immediately.

**IMPORTANT** - In case of internal contact, DO NOT give fluids that induce vomiting.

## ⚠ Warning

### California Proposition 65



Battery posts, terminals, and related accessories contain lead and lead compounds, chemicals known to the State of California to cause cancer, birth defects, or other reproductive harm. Wash hands after handling these items.

## ⚠ Warning



Wear eye protection when starting a forklift with jump start cables. Improper jump start procedures could cause the battery to explode, which could result in death or serious injury.

- Never jump start a frozen battery, as it can explode. Let the battery thaw out before charging.
- NEVER jump start the forklift when travel select lever is in gear, which can cause the forklift to lurch forward or backward, and could result in death, serious personal injury, or property damage.
- To avoid death or serious injury when jump starting with another vehicle, make sure the two (2) vehicles are not touching.
- DO NOT allow jump start cable ends to contact each other.
- Connect charged battery positive (+) to stalled battery positive (+).
- Connect charged battery negative (-) to stalled forklift ground. Make the connection to the stalled forklift ground last.
- Connect jump start cable to stalled forklift ground a safe distance from the battery to prevent sparks near the battery.
- Jump start only with a power source with the same voltage as the stalled forklift.
- Jump start power source must have a negative ground electrical system.
- Turn off all lights and accessories on the stalled forklift to prevent them from operating when the power source is connected.
- Electrolyte is an acid and can cause injury if it contacts the skin or eyes.



Tires must have proper ballast. DO NOT replace foam-filled tires with pneumatic tires.

**Pre-Operation Inspection Checklist**

**Walk around the ENTIRE forklift while visually performing the pre-operation inspection.**

- Check that "Do Not Operate" tags have not been placed on the forklift.
- Check that load capacity charts are legible.
- Check that frame level indicator is working properly.
- Check condition and operation of the seat belt and mounting hardware.
- Check that Operation and Safety Manual is in the protective case and legible.
- Check forks for welds, cracks, misalignment, or any other damage.
- Check that carriage assembly crossbar is straight and in place to prevent forks from changing position or coming off the carriage.
- Check all hydraulic hoses and hose connections for wear or leaks.
- Check tilt cylinder for leaks or any other damage.
- Check boom for straightness or any other damage.
- Check all four (4) tires and wheels for:
  - Punctures, cracks, cuts, gouges, bulges, foreign objects, or any other damage to tires.
  - Loose or missing lug nuts.
  - Bent flanges or any other damage to rims.
- Check front and rear sway cylinders and hoses for leaks or any other damage.
- Check mirrors for cracks, cleanliness, and proper adjustment.
- Check hydraulic reservoir sight gauge for proper fluid level. Add hydraulic fluid, if necessary.
- Check engine compartment for:
  - Loose or damaged belts, hoses, and radiator blades.
  - Coolant reservoir level. Add radiator coolant, if necessary.
  - Engine oil level. Add engine oil, if necessary.
  - Electrical wires and connectors.
- Check transmission fluid level.
- Check front and rear axles for leaks or any other damage.
- Check main boom cylinders and hydraulic lines for leaks or any other damage.
- Check battery terminals for corrosion.
- Check battery for cracked, melted, or damaged case.
- Check electrical connections on rear sway cylinder.
- Check that all labels are legible. Replace any damaged or illegible labels.
- Check that operator's cab is empty of all trash, debris, or any loose items.
- Check that personal belongings are secured in the personal storage box.
- Check that pedals, and non-skid surfaces are clean and free of grease, oil, dirt, snow, or ice.

Date: \_\_\_\_\_  Initials: \_\_\_\_\_

## Functional Tests

### ⚠ Warning



**Perform a pre-operation inspection and functional tests at the beginning of each work shift. Perform the pre-operation inspection of the forklift first. DO NOT**

**perform the pre-operation inspection with the engine running or hot. Contact with moving or heated parts could cause death or serious injury.**



**Perform the pre-operation inspection and functional tests in an open area. Inspections and functional tests may require assistance. Keep the assistant**

**visible and a safe distance from the forklift to prevent death or serious injury.**



**Remove forklift from service and place “Do Not Operate” tags on the starter switch and steering wheel if anything is found to be in need of repair or maintenance, defective,**

**or unsafe in any way.**

**The safety, efficiency, and service life of your reach forklift will be increased by performing functional tests at the beginning of each shift. If any of the items in the functional tests are not operating properly or within set tolerances, stop the forklift, follow proper shut down procedures, tag the forklift with “Do Not Operate” tags, and have a qualified mechanic service or repair the forklift before placing it into service again.**

## Functional Test Checklist

- Operate the boom control handle forward and backward to raise and lower boom.
- Operate the boom control handle left and right to extend and retract boom.
- Operate the attachment tilt thumb switch up and down to tilt the attachment.
- Operate the sway control handle left and right to sway frame left and right.
- Operate the auxiliary attachment control lever (if a hydraulic attachment is being used).
- Turn work lights on and off.
- Press the horn button to sound horn.
- Place the travel select lever in reverse to sound the backup alarm.
- Release parking brake.
- Operate the forklift in forward and reverse.
- Test the gear select lever while operating the forklift in forward and reverse.
- Test the service and parking brakes.
  - Apply the service brake pedal after the forklift begins to move and the forklift should stop immediately.
  - Apply the parking brake. The forklift should not move unless the parking brake is released.
- Test each steering function. Operate the forklift in forward and reverse at low idle speed and turn the steering wheel approximately 1/4 turn in each direction for each of the following modes:
  - Align the wheels and set the Steering Select switch to crab steering.
  - Align the wheels and set the Steering Select switch to 2 wheel (2W) steering.
  - Align the wheels and set the Steering Select switch to 4 wheel (4W) steering.
- Check gauges after the engine warms to the proper operating range.
  - Check the voltage gauge. The voltage gauge should read between 11 to 15 volts.
  - Check the engine coolant temperature gauge. The engine coolant temperature gauge should read between 180 to 200°F.
  - Check the engine oil pressure gauge. The engine oil pressure gauge should read between 40 to 80 PSI.

Operator Maintenance



Figure 7-1. Check Hydraulic Oil Sight Gauge.

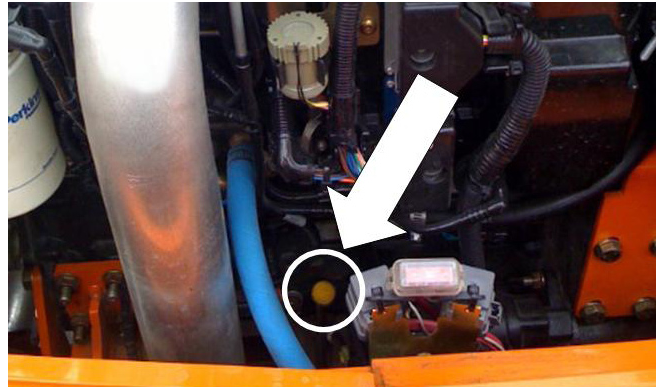

Figure 7-4. Check Engine Oil Level. Add Engine Oil, If Necessary.



Figure 7-2. Add Hydraulic Oil, If Necessary.



Figure 7-5. Check Battery Case and Terminals.



Figure 7-3. Check Coolant Reservoir Level. Add Coolant, If Necessary.



Figure 7-6. Store Operation and Safety Manual In Protective Case.

## Before Starting Forklift

### ⚠ Warning



Failure to use proper safety procedures when mounting and dismounting the forklift could result in death or serious injury.

injury.

- Keep steps clear of dirt, mud, snow, ice, debris, and other hazards.
- Face the forklift for mounting or dismounting. Use hand holds and steps to maintain three (3) points of contact at all times, either both hands and one foot or both feet and one hand.
- DO NOT use the controls, steering wheel, or foot pedals as hand holds or steps. Avoid accidentally engaging or disengaging a control.



DO NOT jump from the forklift. Clothing can get caught on pedals, levers, or other protruding parts. Landing on uneven surfaces could result in death or serious injury.

serious injury.

1. Master battery disconnect on.
2. Use safe mounting/dismounting procedures to enter the operator cab.
3. Adjust the operator seat for position and comfort. (Refer to Seat Adjustment section in this manual)
4. Adjust mirrors (this may require assistance).
5. Adjust the side console control panel.
6. Fasten seat belt.
7. Make sure the travel select lever is set to NEUTRAL (N) and the Parking Brake is ON (engaged).

**NOTE:** The engine will only start when the travel select lever is in NEUTRAL (N) and the Parking Brake switch is ON (engaged).



Figure 7-7. Travel Select Lever Must Be In NEUTRAL (N) To Start The Reach Forklift.



Figure 7-8. Parking Brake Switch (A) Must Be ON (Engaged) To Start The Reach Forklift.

**Starting Forklift**

**Normal Starting**

**Warning**



To prevent death, serious injury, or property damage, the operator must be seated with seat belt fastened, arms, legs, and head completely inside the Rollover Protection Structure/Falling Object Protection Structure (ROPS/FOPS), the travel select lever in NEUTRAL, and the Parking Brake switch ON (engaged) BEFORE starting the forklift.

Protection Structure/Falling Object Protection Structure (ROPS/FOPS), the travel select lever in NEUTRAL, and the Parking Brake switch ON (engaged) BEFORE starting the forklift.

1. Place key in Ignition switch. (Continue with step 3)



Figure 7-9. Key and Ignition Switch.

**Caution**

Release the key immediately once the motor starts. If the motor does not start, DO NOT crank the starter motor continuously for more than 15 seconds. Failure to release the key after the motor has started or continuous cranking may damage the starter motor.

**Cold Starting**

2. Turn key in Ignition switch clockwise to the PREHEAT position and hold the key at PREHEAT for approximately one (1) minute.



Figure 7-10. Hold Key At PREHEAT.

3. Turn key in Ignition switch clockwise to the START position.

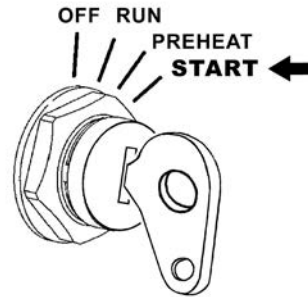

Figure 7-11. Turn Key In Ignition Switch To START.

4. Release the key immediately after the engine starts. The Ignition switch will automatically return to RUN.

**NOTE:** The PREHEAT and START positions are spring-loaded. When the key is released, the Ignition switch will automatically return to the RUN position.



Figure 7-12. Ignition Switch Automatically Returns To RUN.

**NOTE:** If the engine fails to start on the first try, wait until the engine and starter come to a complete stop before cranking the engine again.

5. After the engine starts, allow the engine to idle for approximately 60 seconds.
6. Apply the service brake pedal and disengage the Parking Brake switch.

## Jump Starting

Jump start or replace the battery of the reach forklift when the battery is discharged to the point that it will not crank the starter.

### Warning



Lead-acid batteries produce flammable and potentially explosive gases. To avoid death or serious injury when checking, testing, or charging batteries:

- DO NOT use smoking materials near batteries.
- Keep arcs, sparks, and open flames away from batteries.
- Provide ventilation for flammable vapors
- Wear proper personal protective equipment, including safety glasses.

Fluid in electric storage batteries contains sulfuric acid, which is poison and can cause severe chemical burns. Avoid all contact of fluid with eyes, skin, or clothing. Use protective gear when handling batteries. DO NOT tip a battery beyond a 45° angle in any direction.

If contact does occur, follow these First Aid suggestions:

- External contact - Flush with water.
- Eyes - Flush with water (including under the eyelids) for at least 15 minutes and get medical attention immediately. Flushing must begin immediately to avoid permanent eye tissue damage.
- Internal contact - Drink large quantities of water or milk to dilute stomach contents. Do not induce vomiting. Get medical attention immediately.

**Important - In case of internal contact, do not give fluids that induce vomiting.**

### Warning



**Wear eye protection when starting a forklift with jump start cables. Improper jump start procedures could cause the battery to explode, which could result in death or serious injury.**

- Never jump start a frozen battery, as it can explode. Let the battery thaw out before charging.
- NEVER jump start the forklift when travel select lever is in gear, which can cause the forklift to lurch forward or backward, and could result in death, serious personal injury, or property damage.
- To avoid death or serious injury when jump starting with another vehicle, make sure the two (2) vehicles are not touching.
- DO NOT allow jump start cable ends to contact each other.
- Electrolyte is an acid and can cause serious injury if it contacts the skin or eyes.
  1. Connect one end of the positive (+) jumper cable to the positive (+) post of the discharged battery.
  2. Connect the other end of the positive (+) jumper cable to the positive (+) post of the charged battery.
  3. Connect one end of the negative (-) jumper cable to the negative (-) post of the charged battery.
  4. Make the final jumper cable connection to the stalled forklift ground at the furthest point from the battery.
  5. Start the forklift. Refer to the Starting Forklift section in this manual.

### Caution

**Release the key immediately once the motor starts. If the motor does not start, DO NOT crank the starter motor continuously for more than 15 seconds. Failure to release the key after the motor has started or continuous cranking may damage the starter motor.**

**NOTE:** If the engine fails to start on the first try, wait until the engine and starter come to a complete stop before cranking the engine again.

6. After the engine starts, let idle for 30 to 60 seconds.
7. Remove the jumper cables in the reverse order of their connection (i.e. negative cable ground connection first, etc.).



Forklift Travel

Steering Modes

**Warning**



**NEVER** use crab or four wheel (4W) steering for traveling at high speeds. Use only two wheel (2W) steering for higher speed travel and slow the forklift before turning. Rapid turning using crab, four wheel (4W), or the optional two wheel rear (2WR) steering could cause tip over, which could result in death, serious injury, or property damage.

Check the turning radius area around the forklift before making a turn, especially if using four wheel (4W) steering or two wheel rear (2WR) steering, which provide a tighter turning radius. Look over your shoulder in the direction of the turn when backing. Failure to remain aware of your turning radius area could result in death, serious injury, or equipment damage.

**Caution**

**DO NOT** change steering modes until the forklift slows or comes to a complete stop. Align all four (4) wheels “straight-ahead”, or perpendicular to the axle, before changing steering mode. Changing steering modes without aligning all four (4) wheels may result in equipment damage.

The reach forklift includes three **STANDARD** modes of steering; crab, two wheel (2W), and four wheel (4W) steering. Use the steering select switch located on the right side of the dash panel to change steering modes.

**Crab Steering**



Crab steering allows all four (4) wheels to turn in the same direction as the steering wheel, allowing the forklift to move “sideways”. Crab steering is useful in a congested work site to line up to a loading location.

**Two Wheel Front Steering (2W)**



Two wheel (2W) steering allows the front wheels to turn in the same direction as the steering wheel. The rear wheels remain in a fixed forward position. Two wheel (2W) steering is useful for traveling at higher speeds.

**Four Wheel Steering (4W)**

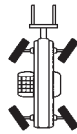

Four wheel (4W) steering allows the front wheels to turn in the same direction and the rear wheels to turn in the opposite direction of the steering wheel. The rear wheels follow the front wheel path. Four wheel (4W) steering is useful for a short turning radius and in muddy or sandy conditions.

**Two Wheel Rear Steering (2WR) (Optional)**

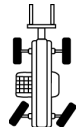

**OPTIONAL** two wheel rear (2WR) steering allows the rear wheels to turn in the same direction as the steering wheel. The front wheels remain in a fixed forward position. **NOTE:** A separate switch is located on the right side of the dash panel to engage and disengage the optional two wheel rear (2WR) steering mode.

**Maximum Fork Sweep**

**Warning**



Allow for adequate clearance between the attachment and other objects when turning. The attachment extends beyond the front of the forklift. The operator must be aware of the maximum sweep of any attachment being used, when turning, to avoid hitting personnel and other objects in the area to prevent death, serious injury, or property damage.

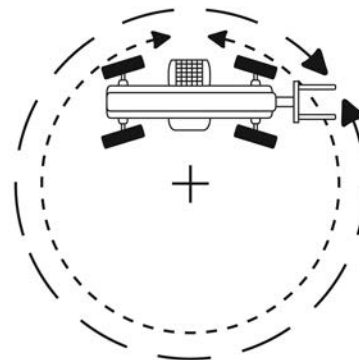

Figure 7-13. Maximum Fork Sweep.

## Starting Travel

### ⚠ Warning



**Use proper safety procedures and avoid hazardous situations while operating the forklift to prevent death, serious injury, or property damage.**

- Check the work site for any hazards before operating the forklift.
- Check the work surface for loose soil conditions and overhead power lines.

### ⚠ Warning



**To prevent death or serious injury, the operator must be seated with seat belt fastened, the travel select lever set to NEUTRAL, the Parking Brake ON (engaged), and the area free of people and obstructions BEFORE starting the forklift.**

1. Start the forklift. Refer to the Starting Forklift section in this manual.
2. Apply service brake.
3. Release parking brake.
4. Rotate the gear select switch to the gear desired.
5. Move the travel select lever to FORWARD or REVERSE for the appropriate direction of travel.
6. Release the service brake pedal.
7. Slowly press the accelerator pedal to start travel.

## Shifting Gears

### ⚠ Warning



**DO NOT shift through multiple gears with a single turn of the gear select lever. Allow the engine speed to slow down before shifting to the next lower gear. Improper use of the gear select lever could cause transmission damage or forklift tip over/roll over and could result in death or serious injury.**

The transmission has four (4) gears that can be used for traveling in forward or reverse.

To shift gears rotate the gear select lever to the next gear

while the forklift is traveling.

- Use first gear (1) for highest torque and pulling power.
- Use higher gears for higher ground speed.
- Never travel in fourth gear (4) when carrying a load.
- Allow the engine speed to slow down before shifting to a lower gear.

## Warning Indicators and Gauges

### ⚠ Warning



**Check warning indicators and gauges on the dash panel frequently during operation. If a warning indicator is illuminated or a gauge shows abnormal readings, stop the forklift, follow proper shut down procedures, tag the forklift with “Do Not Operate” tags, and have a qualified mechanic service or repair the forklift BEFORE placing it into service again. Ignoring warning indicators can cause improper performance, which could result in death, serious injury, or property damage.**

There are three (3) warning indicator lights on the dash panel that illuminate during critical circumstances. All three (3) warning indicators demand immediate attention and forklift servicing. In many cases the forklift should be shut down as soon as practical to prevent serious mechanical failure.

The hydraulic oil temperature indicator illuminates when the oil temperature is above 180°F (82°C). Stop and idle the engine, allowing time for cooling. If the indicator does not go out after five (5) minutes, shut the engine down.



Figure 7-14. Hydraulic Oil Temperature Indicator.

The low brake pressure indicator illuminates if the hydraulic brake oil pressure gets low.

If the low brake pressure indicator is illuminated, stop the forklift, follow proper shut down procedures, tag the forklift with "Do Not Operate" tags, and have a qualified mechanic service or repair the forklift BEFORE placing it into service again.

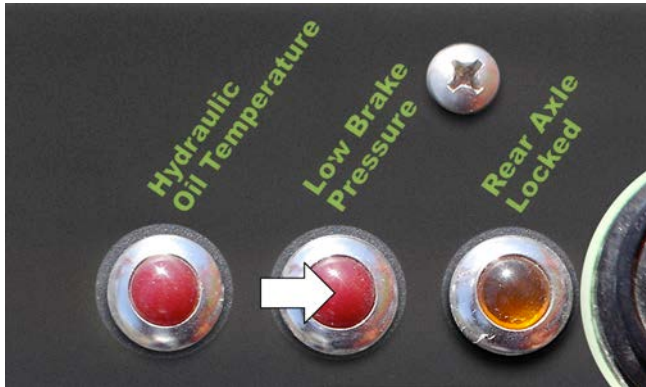

Figure 7-15. Low Brake Pressure Indicator.

The rear axle lock indicator illuminates when the forklift is in the axle lock mode. The rear axle locks when the parking brake is set to ON (engaged), the transmission is in NEUTRAL or the service brake applied, and when the boom is above 40°.

If the rear axle lock indicator does not illuminate, stop the forklift, follow proper shut down procedures, tag the forklift with "Do Not Operate" tags, and have a qualified mechanic service or repair the forklift before placing it into service again.

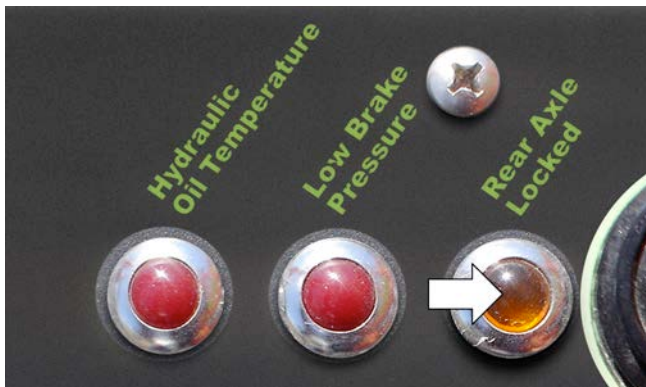

Figure 7-16. Rear Axle Lock Indicator.

### Stopping Travel

1. Stop the forklift by applying the service brake pedal.
2. Downshift the forklift to a lower gear, if necessary, to slow the forklift until it comes to a complete stop.
3. Move the travel select lever to NEUTRAL (N).

For information call (800) 497-1704

4. Set the parking brake to ON (engaged).

### Warning



**To prevent death, serious injury, or property damage, apply service brakes until the forklift comes to a complete stop, move travel select lever to NEUTRAL (N), set the parking brake switch to ON (engaged), lower and retract the boom, and shut off the engine before exiting the forklift.**

### Changing Travel Direction

### Warning



**Make sure the forklift comes to a complete stop before moving the travel select lever. A sudden change in direction of travel, while carrying a load, can reduce stability and/or cause the load to shift or fall, which could result in death, serious injury, or property damage.**

1. Stop the forklift by applying the service brake pedal. If necessary, shift to a lower gear to help slow the forklift.
2. Move the travel select lever to FORWARD (F) or REVERSE (R).
3. Release the service brake pedal.
4. Slowly press the accelerator pedal to start travel.

### Shut Down Procedure

1. Park the forklift on level ground, if possible.
2. Stop the forklift by applying the service brake pedal.
3. Place the travel select lever in NEUTRAL (N) and set the parking brake to ON (engaged).
4. Lower the boom and rest carriage on ground.
5. Turn the ignition key to OFF and remove the key.
6. If the forklift is parked on an incline, block the wheels.

## Refueling

### ⚠ Warning



**Engine fuel is flammable and could cause a fire or explosion. To prevent death or serious injury, DO NOT smoke while**

**refueling and keep sparks and open flames away from the forklift.**

1. Make sure the forklift is level to obtain an accurate fuel level reading.
2. Shut off the engine.
3. Ground the fuel nozzle against the filler neck to avoid sparks.

## Fuel Types

Use ASTM #2 diesel fuel with a minimum cetane rating of 40 for better fuel economy and performance under most operating conditions.

- Use standard #2 diesel fuel for operating at temperatures above 32°F (0°C).
- Use a blend of #1 and #2 diesel fuel ("winterized" #2 diesel) for operating at temperatures below 32°F (0°C).
- Fuels with cetane ratings higher than 40 may be needed in higher altitude or an extremely low temperature climate to prevent misfiring and excessive smoke.

## Attachments

### Attachment Disclaimer

### ⚠ Warning



**DO NOT exceed the manufacturer's rated load for any auxiliary attachment. Any attempt to lift or carry loads in excess of the manufacturer's rated load could cause**

**forklift tip over, loss of load, or structural damage which could result in death, serious injury, or property damage.**

Xtreme Manufacturing makes no representations or warranties, expressed or implied, as to the design, manufacture, or fitness for use with this forklift of any third party attachment. This forklift is not intended to be used and should not be used with an attachment

that would alter the center of gravity or stability of this forklift. Xtreme Manufacturing assumes no liability for any third party attachment that would alter the center of gravity or stability.

## Fork Ratings

### ⚠ Warning



**DO NOT exceed forklift capacity of 12,000 pounds (5,443 kilograms). The total rated capacity of the forks being used must equal or exceed forklift capacity. Forks can break causing loss of load and could result in death or serious injury.**

All approved forks for this forklift are marked with a maximum load capacity rating (A). This rating is stamped on the left edge of the fork just below the fork pivot shaft. The rating is listed in U.S. pounds and based upon a 24 inch (610 mm) load center (B). This rating specifies the maximum load capacity that the individual fork can safely carry at a maximum load center of 24 inches (610 mm).

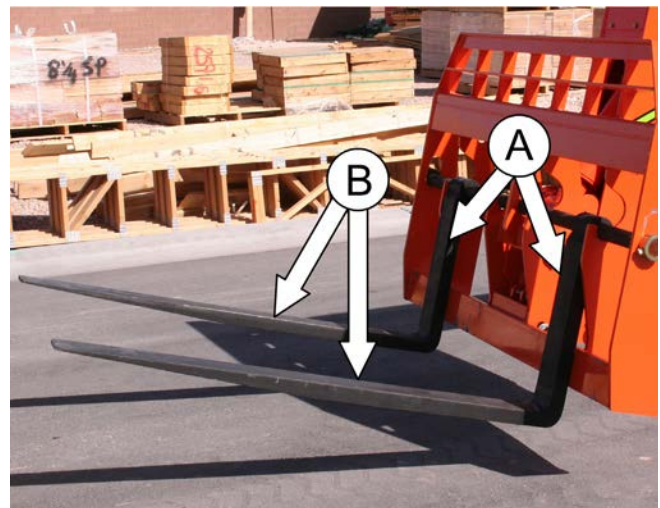

**Figure 7-17. Fork Ratings.**  
(A) Maximum Load Capacity Rating. (B) 24 Inch Load Center.

Because forks are always used in multiples, the total rating of any combination of forks will be the sum of their rated capacity. Other than block forks, all forks should be used in matched pairs. Block forks should be used in matched sets.

The maximum load capacity for this forklift is 12,000 pounds (5,443 kilograms). The matched pair or set of forks used on this forklift should have total load ratings which equal or exceed 12,000 pounds (5,443 kilograms). When the load rating of the forklift differs from the load capacity of the forks, the lower value becomes the overall load capacity.

**Standard Carriage Operation**

The standard carriage uses manually adjustable forks and can be tilted up or down by using the thumb switch on the control handle.

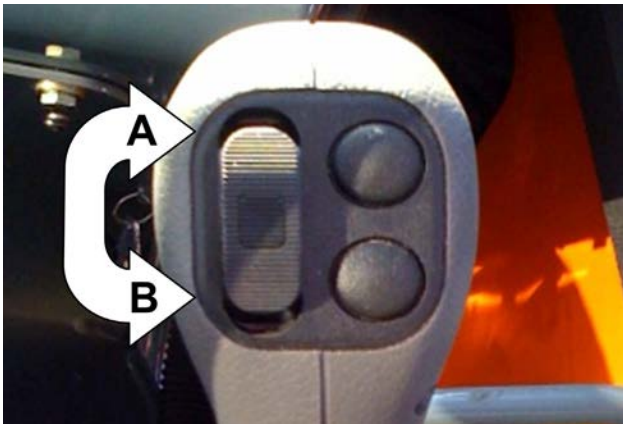

Figure 7-18. Attachment Tilt Control Switch. (A) Attachment Tilt Down. (B) Attachment Tilt Up.

**Swing Carriage Operation (Optional)**

The swing carriage pivot left or right using the auxiliary attachment control lever.



Figure 7-19. Auxiliary Attachment Control Lever.

**Warning**



Hydraulic attachments have a maximum hydraulic pressure rating. Failure to make sure the attachment is equipped with a pressure reducing valve, or is rated to be equal or greater than 4,000 psi (276 bar), which is the maximum pressure of the forklift auxiliary hydraulic system at the quick-disconnect couplers, could result in death or serious injury.

When the auxiliary attachment control lever is moved right or left it activates hydraulic pressure through the quick attach couplers to move the carriage.

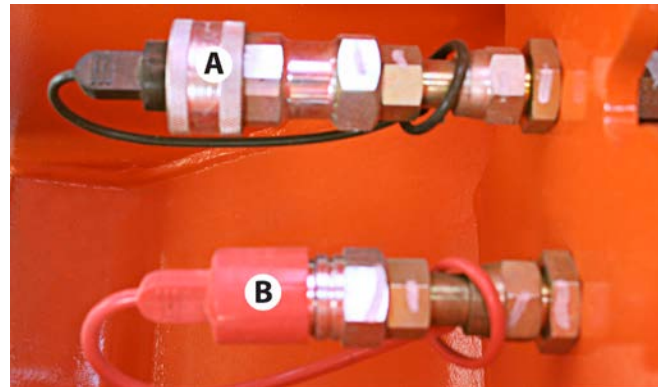

Figure 7-20. Quick Attach Couplers For Hydraulic Systems. (A) Female Coupler. (B) Male Coupler.

**Quick Attach System**

This forklift includes a quick attach system that allows for easy attachment changes. Perform attachment connection and removal procedures on level ground.

**Attachment Connection**

**Warning**



Improper connection of an auxiliary attachment can result in death or serious injury. Attachments not locked into place could become unstable and fall on the operator or other personnel near the forklift, which could result in death or serious injury.

- Make sure attachment locking devices are always in place.
- DO NOT operate the forklift until you have positive indication that the quick attach pin and lock lever are fully engaged.

1. Position the forklift directly behind the attachment.

**NOTE:** Allow enough distance to extend the boom approximately 18 to 20 inches (0.46 to 0.5 meters).

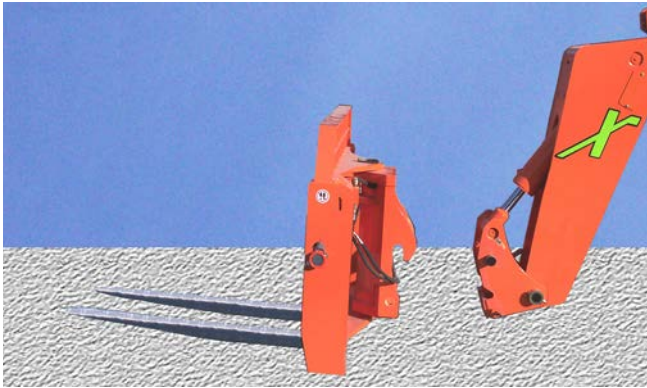

**Figure 7-21. Position Quick Attach Adapter In Line With Attachment.**

2. Tilt the quick attach adapter forward.
3. Extend the boom and/or drive the forklift forward until pivot pins (A) are below and between the two (2) attachment hooks (B).

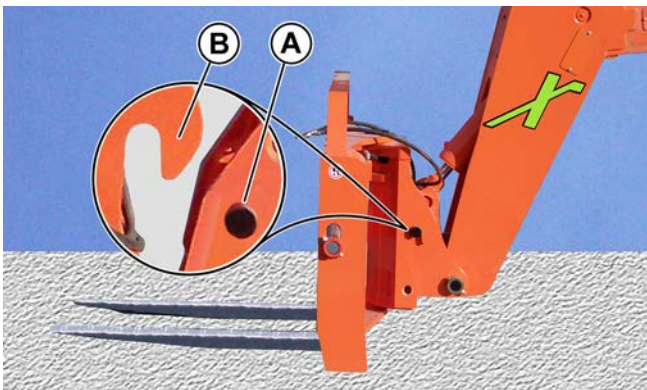

**Figure 7-22. Drive Vehicle Forward To Align Pivot Pins (A) With Attachment Hooks (B).**

4. Raise the boom until pivot pins (A) have seated fully in attachment hooks (B).

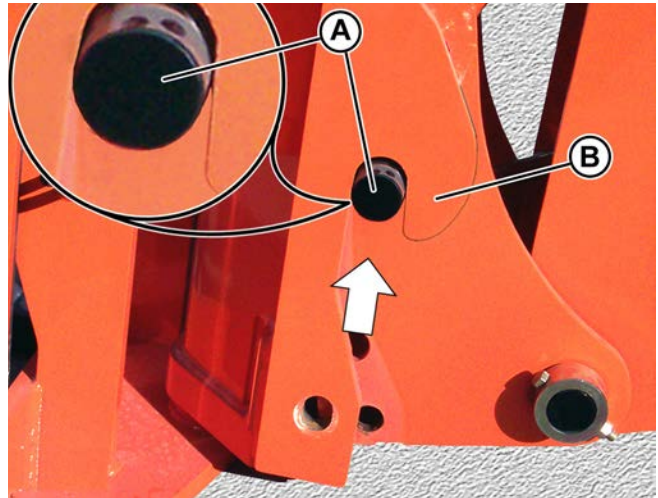

**Figure 7-23. Raise Boom To Seat Pivot Pins (A) In Attachment Hooks (B).**

5. Tilt the attachment up slightly. The quick attach adapter should be tight against the rear of the attachment. Align the holes between the quick attach adapter and attachment.

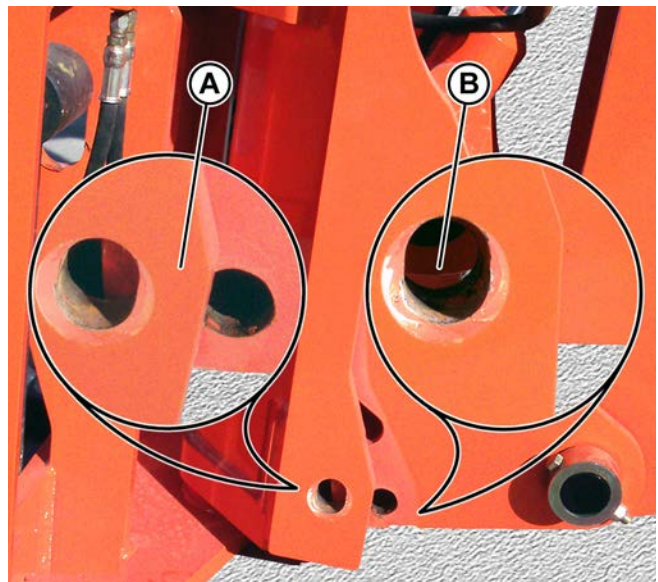

**Figure 7-24. Tilt Attachment To Align Holes Between Quick Attach Adapter and Attachment. (A) Not Aligned. (B) Aligned.**

- 6. Raise the quick attach lock lever.



Figure 7-25. Raise Quick Attach Lock Lever.

- 7. With lock lever raised, insert quick attach pin completely through the attachment and quick attach adapter.

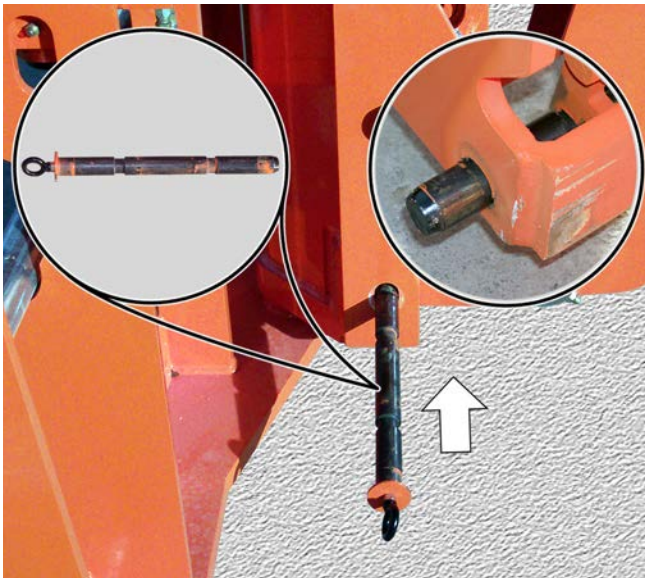

Figure 7-26. Insert Quick Attach Pin Through Attachment and Quick Attach Adapter.

- 8. Release the quick attach lock lever and make sure it has lowered and seated itself in groove (A) of the quick attach pin.

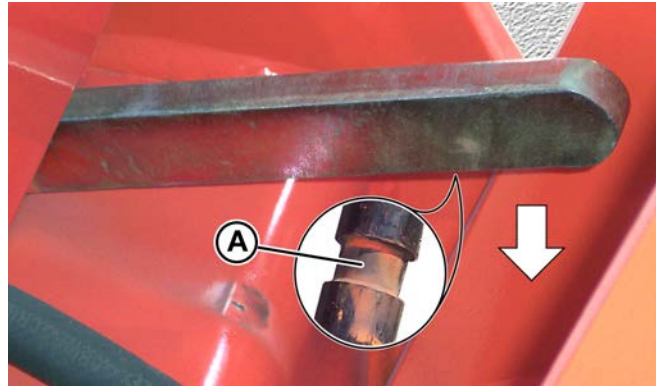

Figure 7-27. Make Sure Quick Attach Lock Lever Is Seated In Groove (A) of Quick Attach Pin.

**Warning**



Hydraulic attachments have a maximum hydraulic pressure rating. Failure to make sure the attachment is equipped with a pressure reducing valve, or is rated to be equal or slightly greater than 4,000 psi (276 bar), which is the maximum pressure of the forklift auxiliary hydraulic system at the quick-disconnect couplers, could result in death or serious injury.

Make sure all hydraulic connections are tight (if equipped).

- 9. Connect the quick attach couplers (this only applies to attachments with a quick attach hydraulic system).

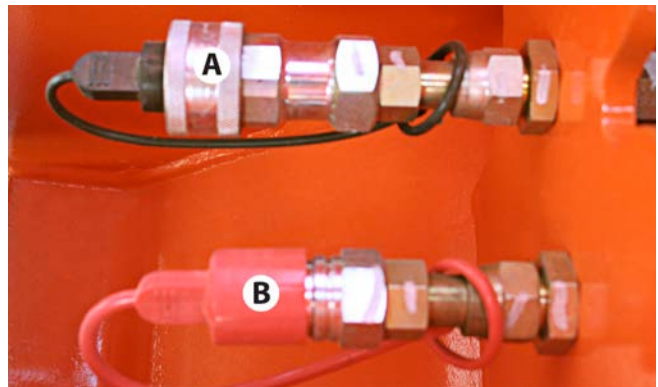
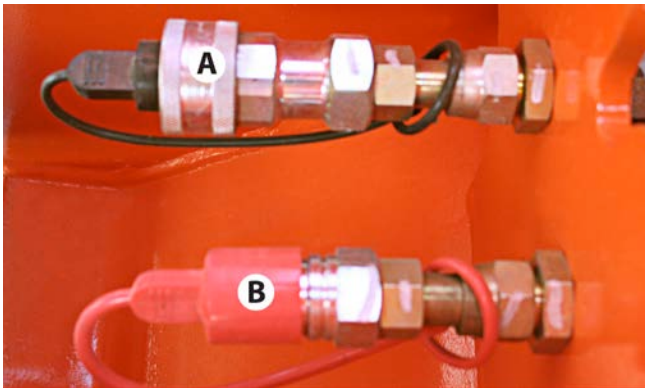

Figure 7-28. Connect Quick Attach Couplers. (A) Female Coupler. (B) Male Coupler.

## Attachment Removal

**NOTE:** To remove a standard carriage with forks, spread the forks apart on the carriage shaft. This provides adequate support for the carriage to stand alone.

1. Bring the forklift to a complete stop.
2. Move the travel select lever to NEUTRAL (N).
3. Set the parking brake switch to ON (engaged).
4. Extend the boom approximately 18 to 20 inches (0.46 to 0.5 meters).
5. With attachment 10"-12" off of the ground, tilt the attachment backward.
6. Disconnect the quick attach couplers (this only applies to attachments with a quick attach hydraulic system).



**Figure 7-29. Disconnect Quick Attach Couplers.**  
(A) Female Coupler. (B) Male Coupler.

7. Raise the quick attach lock lever.



**Figure 7-30. Raise Quick Attach Lock Lever.**

8. Pull out the quick attach pin at the bottom of the quick attach adapter.

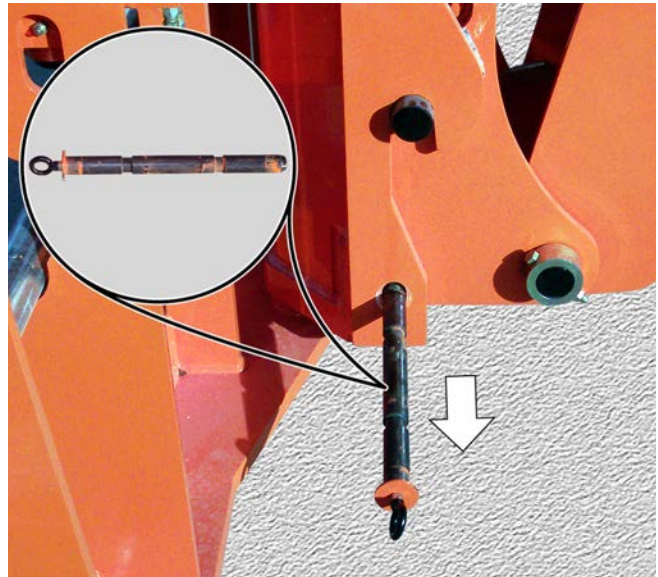

**Figure 7-31. Pull Quick Attach Pin from Attachment and Quick Attach Adapter.**



- Lower the attachment to the ground in a level position.



Figure 7-32. Lower Attachment to Ground in Level Position.

- Tilt and lower boom until pivot pins (A) have disconnected from attachment hooks (B).

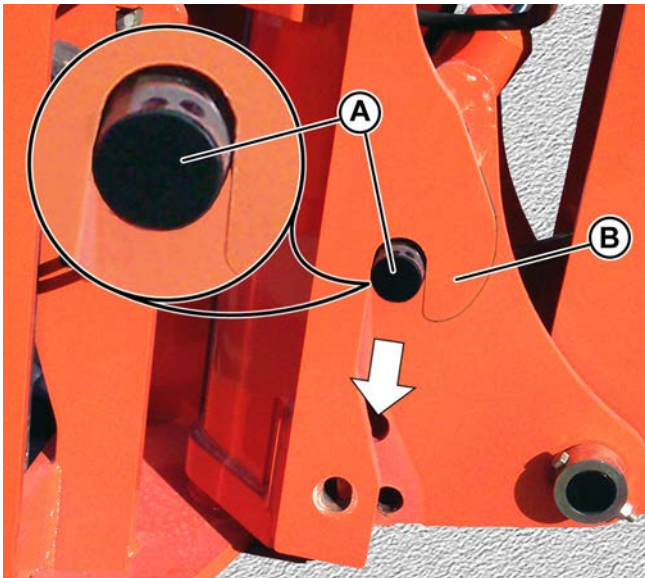

Figure 7-33. Tilt and Lower Boom to Release Pivot Pins (A) from Attachment Hooks (B).

- Retract the boom to fully disconnect the attachment from the quick attach link.

**Load Handling**

**⚠ Danger**



Death or serious injury by electrocution will result from contact with or inadequate clearance with energized power lines or apparatus.

- Never operate the forklift in an area where active overhead power lines, overhead or underground cables, or other power sources exist.
- Contact the appropriate power or utility company to de-energize power lines or take other suitable precautions.



Keep the forklift, attachments, and loads a safe distance from electrical power lines.

- Remain at least 10 feet (3 meters), plus an additional 0.4 inches (10 millimeters) for each 1,000 volts over 50,000 volts, from active power lines and other power sources.
- Work site operating directives and/or local or state codes might require a greater distance.
- Know the maximum height and reach of this reach forklift.

**⚠ Warning**



Failure to follow proper safety procedures when lifting, lowering, and traveling with a load could cause death, serious injury, or property damage.

**DO NOT** exceed forklift capacity of 12,000 pounds (5,443 kilograms). The total rated capacity of the forks being used must equal or exceed forklift capacity. Forks can break causing loss of load and could result in death or serious injury.



**DO NOT** exceed the rated load for any attachment. Any attempt to lift or carry loads in excess of the manufacturer's rated load could cause forklift tip over, loss of load, or structural damage which could result in death, serious injury, or property damage.

## ⚠ Warning



Failure to keep personnel clear of the load area while the load is being raised or lowered could cause death or serious injury. **DO NOT** lift, swing, or move a load over anyone or over a forklift cab.

- Review the rated load capacity of each auxiliary attachment before performing any operation.
- Use the correct load chart and **NEVER** exceed specified weights and load centers.
- **DO NOT** exceed the manufacturer's recommended load capacity.
- **DO NOT** operate the forklift with an unsafe load distribution.
- Adjust the load as necessary, especially for nonstandard loads.
- Use caution when handling loose material that can fall into the cab.
- Remove overhanging load materials, when possible, and watch for sliding material.
- **DO NOT** reach a load over posts or other objects that can enter the cab, if tipped.
- Avoid sudden stops, starts, or turns.

## Suspended Loads

## ⚠ Warning



Avoid carrying a suspended load. If necessary, secure the load by attaching it to the forklift tie-downs and/or have another person assist with safely steadying the load. The handling of suspended loads can introduce dynamic forces drastically affecting the stability of the forklift. Grades and sudden starts, stops, and turns can cause the load to swing and create a hazard if not stabilized. Swinging loads can become unstable, and could cause death, serious injury, or property damage.

1. Do not exceed the forklift's load capacity (as noted on the load chart).
2. Only lift the load vertically, and never drag it horizontally.
3. Transport the load with the bottom of the load and the boom as low as possible.
4. With the load elevated, move the forklift slowly

and cautiously. Only move the forklift to the extent needed to raise, transport, and place the load.

5. Use guy lines to restrain load swing if possible.

## Pick Up A Load

1. **Use the correct load chart to review the rated load capacity of the auxiliary attachment being used. NEVER exceed specified weights and load centers.**
2. Approach the load slowly and squarely with the fork tips straight and level.
3. Adjust the spacing of the forks so they engage the pallet or load at its maximum width. **NEVER** use just one fork to lift a load.
4. Tilt the attachment forward so the forks hang freely on the fork shaft.
5. Insert forks under the load until the load is against the fork frame.
6. Tilt the forks back, and raise the boom slightly to secure the load.

## Carry A Load

1. Carry the load as low as possible while maintaining good ground clearance and visibility.
2. Back away slowly.
3. To travel with a load, use first gear (1) for highest torque and pulling power. **NEVER** travel in fourth gear (4) when carrying a load.

## Place A Load

1. **Before placing the load, refer to the appropriate load capacity chart to determine safe boom extension range.**
2. Set the Parking Brake switch to ON (engaged).
3. Set the Declutch switch to ON.

## ⚠ Warning



**Use of the frame sway control with the boom raised above horizontal could cause tip over, which could result in death or serious injury. Always use the frame sway control to level the forklift BEFORE raising the boom above horizontal. If the forklift cannot be leveled using the frame sway control, do not attempt to raise or place a load. Reposition forklift or have surface leveled.**

4. Use the frame sway control to level the forklift. For additional information, refer to the Frame Leveling section in this manual.
5. Align the forks at the level the load is to be placed.
6. Extend the boom slowly until the load is just above the area where it is to be placed.
7. Lower the boom until the pallet rests in position and the forks are free to retract.
8. Retract the forks slowly from under the load.

### Load Shift

1. If the load shifts, stop the forklift immediately.
2. Lower and adjust the load to center its weight.
3. If the load shift is too great for adjustment, rearrange the load before attempting to move the forklift.

### Elevating Personnel

#### Warning

**Use only a compliant work platform to lift or lower personnel. Never drive the vehicle with the work platform in a raised position or with personnel on board, even for a short distance. Doing so could result in death, serious injury, or property damage.**

**Please refer to ANSI/ITSDF B56.6 for additional design and operating information regarding elevating personnel.**

#### Design Requirements For A Personnel Platform:

- 1) Platform floor must have a slip resistant surface located not more than 8" above the normal load supporting surface of the fork.
- 2) Platform floor dimensions shall not exceed two times the load center distance. This floor dimension is measured parallel to the longitudinal center plane of the vehicle.
- 3) Platform floor width shall not be greater than the overall width of the vehicle, measured across the load bearing tires, plus 10" on each side.
- 4) Minimum space requirements for each person on the platform shall not be less than 18" in either direction.
- 5) 4" minimum height toe plate around the perimeter of the platform which may be omitted at the access opening:
- 6) On overhead protection device, when requested by the user.
- 7) Protection must be provided for the personnel in their

normal working position on the platform from moving parts of the rough terrain forklift that represent a hazard.

#### 8) Information prominently indicated on the platform;

**A) Maximum work load including personnel and equipment.**

**B) Weight of empty platform.**

**9) Provide a means so that the platform can only be centered laterally on the rough terrain forklift truck and retained against the vertical face of the forks, carriage, or lifting mechanism.**

**10) Provide a means to securely attach the platform to the lifting mechanism, and to prevent the platform from inadvertent pivoting.**

**11) Provide restraining means for securing personnel such as an anchorage for attaching the lanyard of a body belt or harness.**

**12) Provide a guardrail or similar structure with a nominal height to the platform floor of 42" around its upper periphery and include a mid rail. It may be hinged, removable, or of chains, and used if proper positioning is easily discernible. Such restraining means shall be capable of withstanding a concentrated horizontal force of 200 lbs applied at the point of least resistance without permanent deformation. A body belt and lanyard is to have an attachment point provided for freedom of movement, and its length is limited to a free-fall of 5' measured from the point of attachment to the operator. The complete system shall be capable of withstanding three consecutive drop tests to simulate a 250 lbs person free falling 6' without allowing the test weight to fall free to the ground. A deceleration device may be included.**

**13) Lanyards shall be arranged so as not to cause a tripping hazard.**

**14) Body belts should have a width of at least 1.75".**

**15) Structural safety factor – all load supporting structural elements of the work platform shall have a structural safety factor of not less than 2 to 1 based on the minimum yield strength of the material used.**

#### Capacity Limitations:

The combined weight in pounds of the platform, load and personnel shall not exceed 33% of the capacity of the related load center position indicated on the machine load chart.

## Preparation and Set-Up:

- 1) **DO NOT** alter or modify the work platform in any manner that is detrimental to its safe use.
- 2) Make sure that the work platform is securely attached to the quick attach or forks. Follow the platform manufacturer's instructions.
- 3) Make sure the platform, carriage and forks are secured to prevent them from pivoting from side to side.
- 4) On side tilt or swing carriage, the carriage must be centered and/or leveled horizontally and vertically. The hydraulic system quick disconnects must also be disconnected and the carriage securely fastened to prevent any tilting or side to side swinging motion.
- 5) Ensure the vehicle has a firm footing and is level.
- 6) Be sure the vehicle is in a level position (side to side) before any operation is begun. Use the frame sway to level the vehicle. If the vehicle cannot be leveled, reposition the vehicle.
- 7) Place the travel select lever in the NEUTRAL position.
- 8) Engage the parking brake switch. Blocking the wheels is also recommended.
- 9) Level the platform in both the side-to-side and front-to-back directions before use.
- 10) Before lifting or lowering personnel, be sure the vehicle lifting mechanism operates smoothly through the entire lifting and lowering of the platform and maintains its self leveling function. The vehicle must operate smoothly both empty and loaded.
- 11) Lift and lower personnel smoothly, with caution, and only at their request.
- 12) Keep hands and feet clear of controls other than those in use.
- 13) Be certain that the path of platform travel is clear of hazards, e.g., storage racks, scaffolds, overhead obstructions, and electrical wires.
- 14) Be sure any lift limiting devices and latches are functioning properly.
- 15) A trained operator shall be in position to control the rough terrain forklift truck. When the operator is not in the operating position, block the truck wheels and apply the parking brake with all controls in neutral.
- 16) Alert elevated personnel before moving the platform. Then move the platform smoothly and with caution.
- 17) Always lower the platform if you must move the rough terrain forklift truck for adjustment in positioning.
- 18) Be certain that personnel and equipment on the platform do not exceed the available space.
- 19) Any body belt, lanyard or deceleration devices which

has sustained permanent deformation or is otherwise damaged shall be replaced.

- 20) Use of railings, planks, ladders, etc. on the platform for purpose of achieving additional reach or height is prohibited.
- 21) Before elevating personnel, the area around and under the work platform should be marked to warn anyone on the ground that overhead work is being done.
- 22) The platform shall be lowered to ground level for personnel to enter and exit. Personnel shall not climb on any part of the rough terrain forklift in attempting to enter and exit.
- 23) Protection must be provided for the personnel on the work platform from pinch points or moving parts while in their normal working position on the platform.
- 24) Provide overhead protection device as required by work site conditions or if requested by the user of the platform.

## Frame Leveling

### Warning



**Use of the frame sway control with the boom raised above horizontal could cause tip over, which could result in death or serious injury. Always use the frame sway control to level the forklift BEFORE raising the boom above horizontal. If the forklift cannot be leveled using the frame sway control, do not attempt to raise or place a load. Reposition forklift or have surface leveled.**

The frame sway control handle has variable motions from the center that control frame sway (right and left).

**Table 11. Frame Sway Functions**

Function	Control Handle Action
FRAME SWAY RIGHT	Move control handle RIGHT.
FRAME SWAY LEFT	Move control handle LEFT.

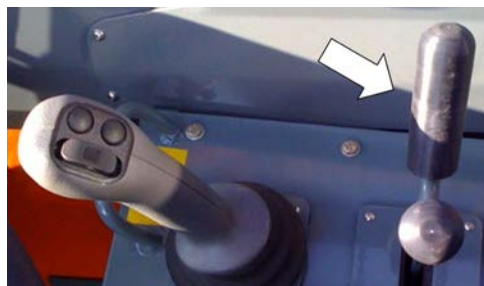

**Figure 7-34. Frame Sway Control Handle.**

The frame sway control handle controls the frame sway (right and left) functions.

To lock the frame sway, place the travel select lever in NEUTRAL or apply the service or parking brake.

**NOTE:** Maximum frame sway is 16° overall or 8° each direction, left and right.

A frame level indicator is mounted on the inside upper right corner of the operator's cab. The frame level indicator allows the operator to view if the forklift has been positioned in a level condition. Always frame sway the forklift right or left until the indicator shows 0° (level).



Figure 7-35. Frame Level Indicator.

### Warning



The reach forklift includes a Frame Sway Override switch. Improper use of the Frame Sway Override switch could cause death, serious injury, or property damage.

The frame sway feature becomes locked and will not operate when the boom is raised 40° or more. Applying service brake, parking brake, and placing travel select lever in NEUTRAL, then pressing the frame sway override switch (the trigger on the front control handle) will override the lockout feature and allow frame sway.

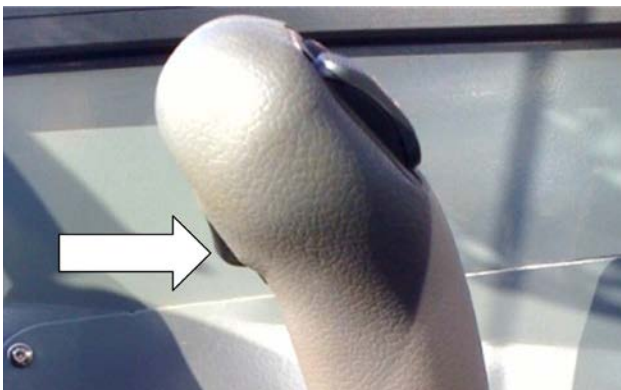

Figure 7-36. Frame Sway Override Switch.

For information call (800) 497-1704

## Load Capacity Charts

### Warning



**DO NOT** exceed rated capacities. Any attempt to lift or carry loads in excess of those shown on the load capacity charts could cause forklift tip over, loss of load, or structural damage which could result in death, serious injury, or property damage.

All load ratings shown on load capacity charts are based on the forklift being on firm, level ground, the forks being evenly positioned on the carriage, the load being centered on the forks, properly sized tires properly inflated, and the forklift being in good operating condition.

Load capacity charts, located on the left side of the dash panel, are provided to assist the operator in determining how to safely operate the boom to pick up, carry, and set down a load with the reach forklift, including what angle, how high, and how far to extend the boom.



Figure 7-37. Typical Load Capacity Chart.

## Using Load Capacity Charts

The reach forklift includes two (2) indicators to assist the operator for accurately using the load capacity charts. These indicators are the boom extend letters and the boom angle indicator.

Boom extend letters are located on the left side of the boom and visible to the operator as the boom is extended. These letters indicate boom extension as it corresponds to the load capacity charts.

**NOTE:** For example, when letter "A" first appears, the boom extension corresponds to the arc of line "A" throughout all the load capacity charts.

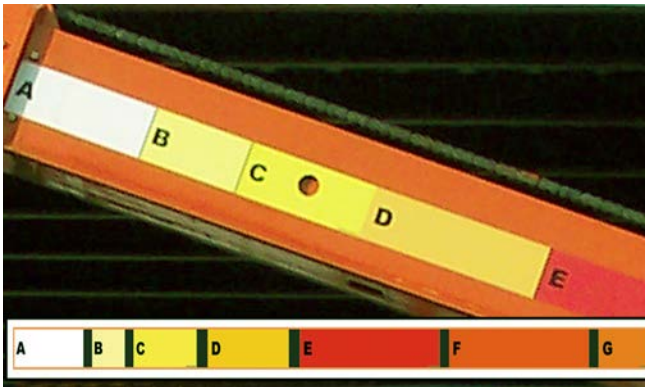

Figure 7-38. Boom Extend Letters.

The boom angle indicator is located on the left side of the boom and is visible from the operator's seat. Use the boom angle indicator to determine the boom angle when referring to load capacity charts.

**NOTE:** The boom angle indicator is a plumb arrow with angular graduations from -5 to +70°.



Figure 7-39. Boom Angle Indicator.

## Reading Load Capacity Charts

To accurately read the load capacity charts, you must determine three (3) things:

- Weight of load being lifted.
- Height of structure where load is to be placed.
- Distance from front tires where load will be placed.

For example:

1. The operator determines load weight and makes sure load does not exceed fork, attachment, or boom capacity.  
The load is 4,000 pounds (1,814 kg).
2. The operator safely moves the load to a loading position:
  - places forks under load
  - tilts and raises load safely
  - fully retracts boom
  - drives forklift to position perpendicular to structure
  - levels the forklift
3. The operator determines height of structure where load is to be placed.  
The structure height is 40 feet (12 meters) from ground level.
4. The operator determines distance from front tires where load will be placed.  
The distance in front of forklift where the load will be placed is 43 feet (13 meters).
5. Operator reads load capacity chart for attachment carriage to learn it will be safe to place the load at any boom angle with the boom extend letter "G" showing.

# Standard Carriage Load Capacity Chart

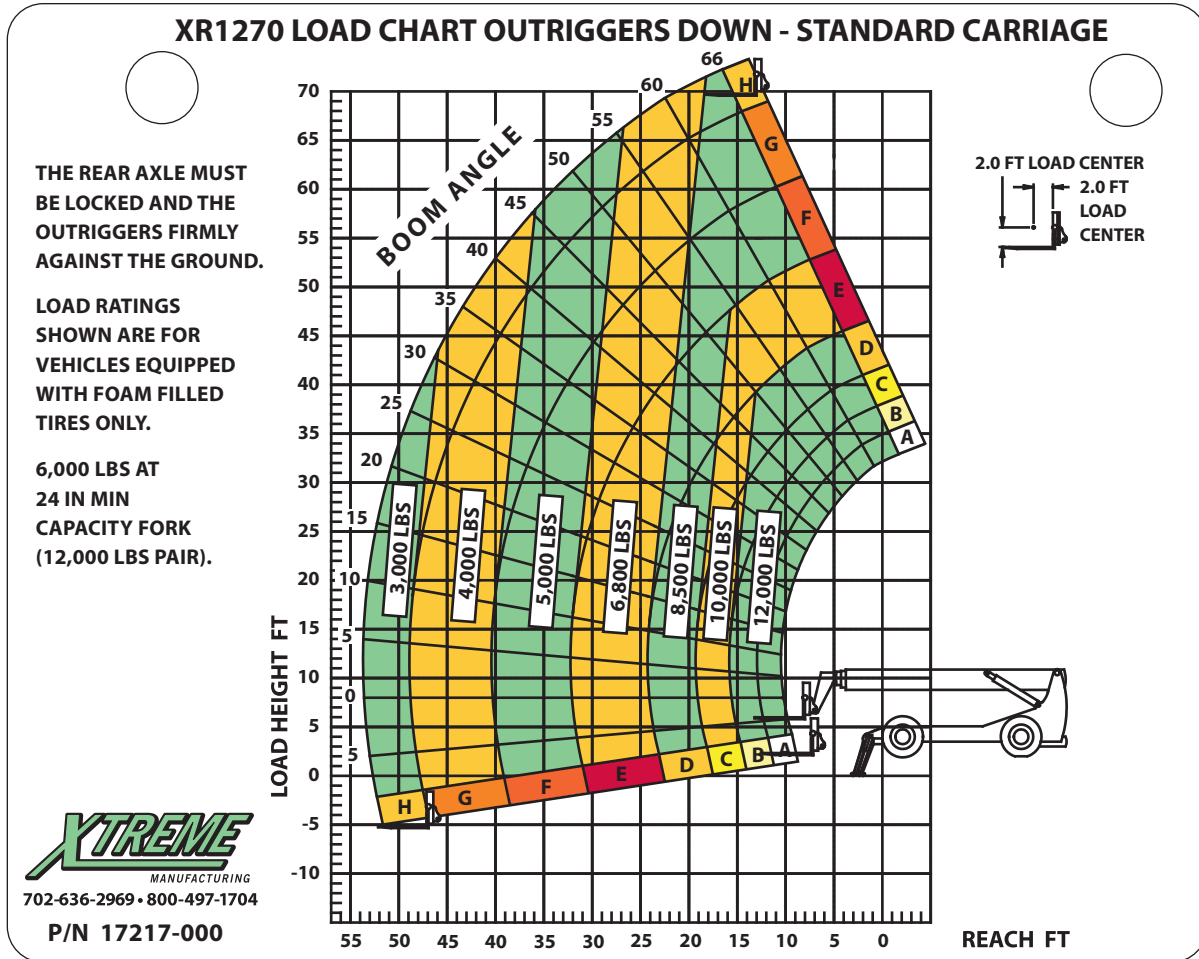

Figure 7-40. Standard Carriage Load Capacity Chart

## Preventive Maintenance

### Establishing A Maintenance Program

The hourmeter installed in the operator control panel displays elapsed engine operating hours and has a total readout of 9,999.9 hours. Use the hour meter and the schedules contained in this section to establish a comprehensive preventive maintenance program.



Figure 8-1. Hourmeter.

### Maintenance Schedules

#### Every Day or 8 Hours of Operation

See **Pre-Operation Inspection Checklist** (pg 49).

#### After First 50 Hours of Operation

- Change engine oil and filters
- Check air filter. Replace if necessary.
- Replace fuel filter and prefilter.
- Check engine hoses and connections for leaks, damage, and tightness
- Check radiator hoses for leaks, damage, and tightness
- Check electrical cables, leads, and connections for damage and tightness
- Check for oil and coolant leaks
- Check condition and tension of drive belts. Use tension meter to check belt tension.
- Lubricate front and rear drive shaft grease fittings
- Lubricate front and rear axle grease fittings
- Change differential oil
- Change wheel-end oil
- Check wheel lug nuts torqued to 380-420 ft-lbs

- Lubricate boom pivot point grease fittings
- Lubricate front and rear axle cylinder pivot point grease fittings
- Lubricate boom roller grease fittings and chains
- Replace hydraulic return line filter
- Replace transmission filter and top off fluid

#### After Every 50 Hours of Operation

- Lubricate boom pivot point grease fittings
- Lubricate front and rear axle cylinder pivot point grease fittings

#### After Every 250 Hours of Operation

- Comply with 50-Hour Maintenance Requirements
- Change engine oil and filter
- Check air filter. Replace if necessary.
- Check tension and condition of drive belts. Use tension meter to check belt tension.
- Lubricate front and rear drive shaft grease fittings
- Lubricate front and rear axle grease fittings
- Check differential oil level
- Check wheel-end oil level
- Check boom chain tension. Adjust if necessary.
- Inspect boom rollers and slide blocks for condition and tightness
- Lubricate boom roller grease fittings and chains



## After Every 500 Hours of Operation

- Comply with 50-Hour Maintenance Requirements
- Comply with 250-Hour Maintenance Requirements
- Replace air filter
- Replace fuel filters
- Empty air filter dust cup
- Check engine hoses and connections for leaks, damage, and tightness
- Check radiator hoses for leaks, damage, and tightness
- Check electrical cables, leads, and connections for damage and tightness
- Check specific gravity of engine coolant
- Replace transmission fluid and filters
- Replace hydraulic reservoir air breather
- Replace hydraulic return line filter
- Replace hydraulic high-pressure filter

## After Every 1,000 Hours of Operation

- Comply with 50-Hour Maintenance Requirements
- Comply with 250-Hour Maintenance Requirements
- Comply with 500-Hour Maintenance Requirements
- Change wheel-end oil
- Change differential oil
- Inspect boom chains

## After Every 2,000 Hours of Operation

- Comply with 50-Hour Maintenance Requirements
- Comply with 250-Hour Maintenance Requirements
- Comply with 500-Hour Maintenance Requirements
- Comply with 1,000-Hour Maintenance Requirements
- Change hydraulic fluid
- Clean or replace hydraulic reservoir strainer

## After Every 4,000 Hours of Operation

- Drain and flush cooling system

### Boom Emergency Lower Down Valve

Both of the lift and extend cylinders are equipped with a needle valve which allows the cylinder to retract without the direct assist of the machine hydraulic power. This feature is intended to be used only in the event of total loss of engine or hydraulic pump failure with an elevated boom.

In any event, the vehicle should be secured until the situation has been properly evaluated. Secure the vehicle and area by following the procedures below:

1. Clear the area around the vehicle of all personnel.
2. Place the shift lever in 'Neutral' and engage the parking brake switch to the on position.
3. Section off a large area under the boom with tape to restrict any personnel from entering this potentially dangerous area.
4. If the load is in a position where it can be removed safely, completely remove the load from the carriage and/or attachment; otherwise leave the load in place.
5. Remove boom access cover on back of boom.
6. Locate needle valve on extend cylinder. Loosen nut on valve, then loosen valve with hex wrench.
7. Fully retract boom with control handle in cab.
8. When boom is fully retracted, tighten valve with hex wrench, then tighten nut to secure valve.
9. Locate needle valves on lift cylinders. Loosen nut on valve, then loosen valve with hex wrench (repeat for both sides)
10. Fully lower boom with control handle in cab.
11. When boom is fully lowered, tighten valve with hex wrench, then tighten nut to secure valve (repeat for both sides).



Figure 8-2. Boom Access Cover.

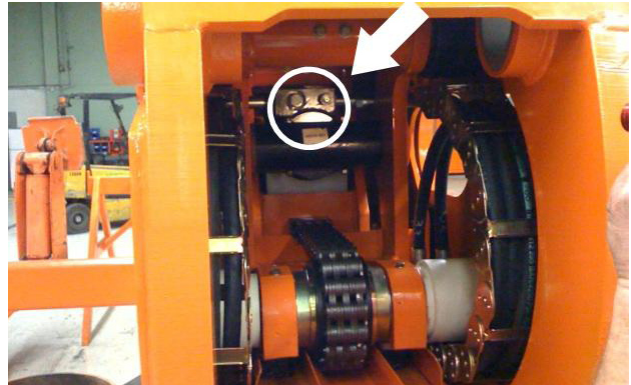

Figure 8-3. Extend Cylinder Lower Down Valve.

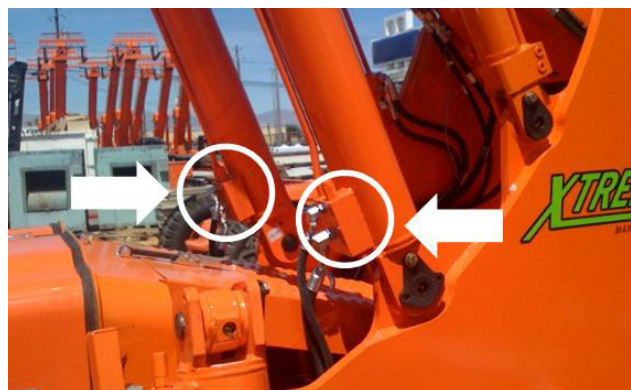

Figure 8-4. Lift Cylinder Lower Down Valve.

### Do Not Operate – Accident Prevention Tags

Before beginning any maintenance or service, place a Do Not Operate Tag on both the starter key switch and the steering wheel, stating that the vehicle should not be operated. Do Not Operate Tags, which can be cut out and used, are included at the end of this manual. Retain these Tags for reuse at a later date.

### New or Additional Operators

At the time of original purchase, the purchaser of this vehicle was instructed by the seller on its proper use. If this vehicle is to be used by an employee or is loaned or rented to someone other than the purchaser, make certain that the new operator is trained, in accordance with OSHA regulations, and reads and understands this Operation & Safety Manual before operating the vehicle.

In addition, make sure that the new operator has completed a walk-around inspection of the vehicle, is familiar with all labels on the vehicle, and has demonstrated the correct use of all controls.

**THIS PAGE INTENTIONALLY LEFT BLANK**

## Lockout/Tagout Procedure

Perform the following procedure to lockout and tagout the forklift. This procedure, requiring a lock, and danger tags are to be used whenever the forklift is unsafe for operation or maintenance.

### Removing Forklift From Service

1. Attach "Do Not Operate" tags to steering wheel and ignition key.
2. Pull back on both battery cover T-handles until they release from holders.
3. Lower battery cover.
4. Set battery disconnect switch to OFF.
5. Lock battery disconnect switch.
6. Attach "Do Not Operate" tag to battery disconnect switch.



#### Do Not Operate Tag.

Note: sample "Do Not Operate" tags are provided in the back of the manual.

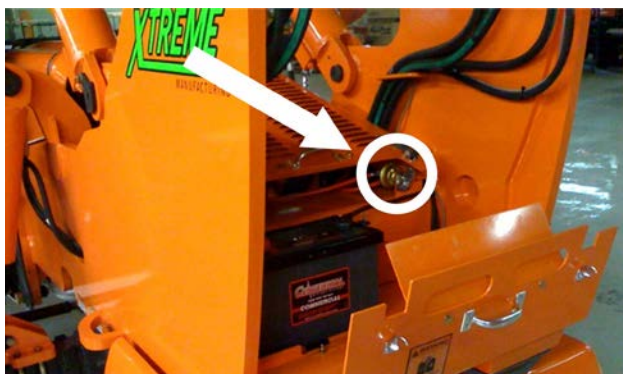

Figure 8-5. Battery Disconnect Switch.

### Warning

**If forklift is unsafe for operation or maintenance, the defect or defects must be clearly documented and posted in a conspicuous place on the forklift. Failure to comply could result in death, serious injury, or property damage.**

### Returning Forklift To Service

When the forklift has been repaired and made safe for operation and maintenance, perform the following procedure to return the forklift to service.

1. Remove lock and "Do Not Operate" tag from battery disconnect switch.
2. Raise and secure battery cover.
3. Remove "Do Not Operate" tags from steering wheel and ignition key.

Do Not Operate Tags







