



Click Here To View
Item at

www.GapPower.com

*Sales • Rentals
Parts & Service*

General's JET SET™

OPERATOR'S MANUAL

J-2900 and J-2000

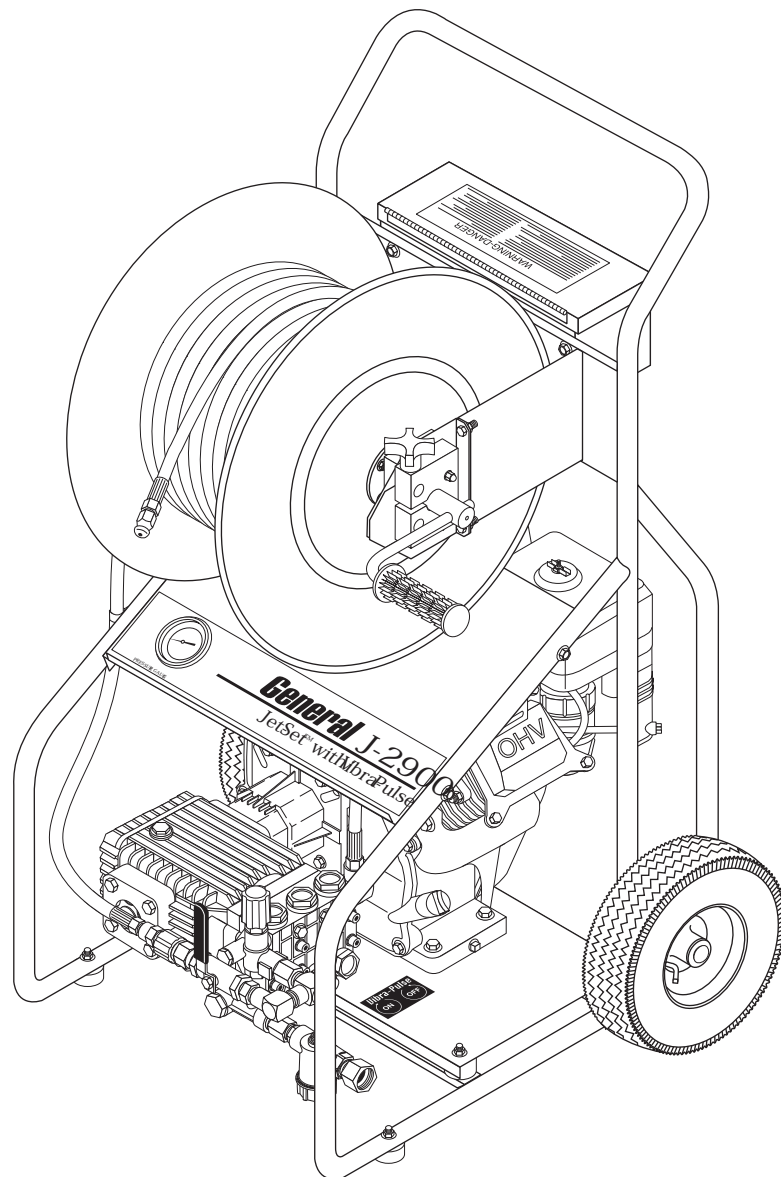

General Wire Spring Co ■ USA ■ 1-412-771-6300 or 1-800-245-6200

Any alteration to equipment without prior written approval of the manufacturer will cancel any warranty or liability extended to the purchaser by manufacturer. For approval or assistance contact General Wire Spring Co.

8.914-324.0 / 97-6117

CONTENTS

Introduction 4

Machine Safety 4-5

Assembly 5

Pre-Operation Check 5

Set-up Procedures..... 5, 8-9

Component Identification & Use, Drain Cleaning 6

Component Identification & Use, Drain Cleaning through Roof Vent..... 7

Operating Instructions..... 9-11

Maintenance 11

Exploded View, J-2900 12

Exploded View, Parts List J-2900 13

Exploded View, J-2000 14

Exploded View, Parts List J-2000 15

HR-200W Handy-Reel, Exploded View & Parts List 16

CR-300 Exploded View & Parts List 17

Pump TX1510G8, Exploded View..... 18

Pump TX1510G8, Parts list 19

Pump XTV3G20D-F7C44, Exploded View 20

Pump XTV3G20D-F7C44, Parts List..... 21

Hose and Spray Gun Assembly (Optional), & Parts List J-2000 22

Hose and Spray Gun Assembly, Exploded View & Parts List J-2900 23

Troubleshooting 24-26

Warranty 27

Model Number _____

Serial Number _____

Date of Purchase _____

The model and serial numbers will be found on a decal attached to the machine. You should record both serial number and date of purchase and keep in a safe place for future reference.

INTRODUCTION

Thank you for purchasing a General's Jet Set™.

This manual covers the operation and maintenance of models J-2900 and J-2000. All information in this manual is based on the latest product information available at the time of printing.

General Wire Spring reserves the right to make changes at any time without incurring any obligation.

Owner/User Responsibility:

The owner and/or user must have an understanding of the manufacturer's operating instructions and warnings before using this General's Jet Set™. Warning information should be emphasized and understood. If the operator is not fluent in English, the manufacturer's instructions and warnings shall be read to and discussed with the operator in the operator's native language by the purchaser/owner, making sure that the operator comprehends its contents.

Owner and/or user must study and maintain for future reference the manufacturers' instructions.

This manual should be considered a permanent part of the machine and should remain with it if machine is resold.

When ordering parts, please specify model and serial number.

MACHINE SAFETY

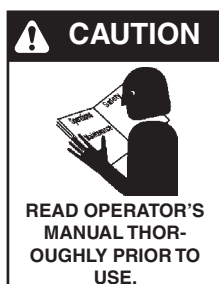

CAUTION: To reduce the risk of injury, read operating instructions carefully before using.

1. Read the owner's manual thoroughly. Failure to follow instructions could cause malfunction of the machine and result in death, serious bodily injury and/or property damage.

2. All installations must comply with local codes. Contact your electrician, plumber, utility company or the selling distributor for specific details.



CAUTION: Risk of asphyxiation. Use this product only in a well ventilated area.

3. Avoid installing machines in small areas or near exhaust fans. Exhaust contains poisonous carbon monoxide gas; exposure may cause loss of consciousness and may lead to death. It also contains chemicals known, in certain quantities to cause cancer, birth defects or other reproductive harm.

chemicals known, in certain quantities to cause cancer, birth defects or other reproductive harm.



WARNING: Flammable liquids can create fumes which can ignite causing property damage or severe injury.

WARNING: Risk of fire. Do not add fuel when the product is operating.

WARNING: Risk of explosion — do not spray flammable liquids.

4. Do not place machine near flammable objects as the engine is hot.
5. Allow engine to cool for 2 minutes before refueling. If any fuel is spilled, make sure the area is dry before testing the spark plug or starting the engine. (Fire and/or explosion may occur if this is not done.)

Gasoline engines on mobile or portable equipment shall be refueled:

- (a) outdoors;
- (b) with the engine on the equipment stopped;
- (c) with no source of ignition within 10 feet of the dispensing point; and
- (d) with an allowance made for expansion of the fuel should the equipment be exposed to a higher ambient temperature.

In an overfilling situation, additional precautions are necessary to ensure that the situation is handled in a safe manner.



CAUTION: High pressure stream of water that this equipment can produce can pierce skin and its underlying tissues, leading to serious injury and possible amputation.

CAUTION: Do not touch engine during operation. The muffler and other parts of the engine get hot and can cause severe burns.



WARNING: High pressure spray can cause particles to become airborne and fly at high speeds.

6. Eye safety devices, rubber gloves, ear plugs and foot protection must be worn when using this equipment.



7. High pressure developed by these machines will cause personal injury or equipment damage. Use caution when operating. Do not direct discharge stream at people or severe injury or death will result.

8. Never make adjustments on machine while it is in operation.
9. Do not operate valve in the off position for extensive periods of time as this may cause damage to the pump.
10. The best insurance against an accident is precaution and knowledge of the machine.
11. General Wire Spring will not be liable for any changes made to our standard machines, or any components not purchased from General Wire Spring.
12. Read engine safety instructions provided.



WARNING: Keep water spray away from electric wiring or fatal electric shock may result.

13. Never run pump dry.
14. Do not allow children to operate the General's Jet Set™ at any time.
15. Inlet water supply must be cold and clean fresh water.

ASSEMBLY

Upon arrival, inspect the shipping crate for damages. Uncrate and examine all parts. Note any damage to machine or components for claims against freight carrier.

The tires on the jets may be partially deflated for packing and shipment. Reinflate tires to the pressure specified on the side of the tire before using the machine.

Jets have antifreeze in the pump to protect it from freezing conditions during shipment and storage. If machine will be stored and operated in a cold climate, follow Freeze Protection instructions on page 11.

PRE-OPERATION CHECK

- Pump oil (SAE 30W non-detergent oil, General)
- Cold clean fresh water supply (6 gpm • 3/4" (15.875mm) • 20 psi)
- Hose, nozzle
- Fuel (unleaded 86 or higher octane)
- Engine oil (SAE 10W40)

SET-UP PROCEDURES

These machines are meant to be used at or near the working area and under operator supervision. If machine must be located out of sight of the operator, special controls may be required for proper machine operation and operator safety.

Locate the equipment on a solid level area with slopes for drainage. Avoid areas where water can be sprayed at machine.

Before using the jet, make sure there are no impurities in the incoming water supply. Turn the water source on for at least 15 seconds, to remove any possible debris in the water before connecting hose to water inlet swivel.

The inlet screen located inside the filter should be cleaned before each use. To clean the inlet screen, unscrew cap beneath the filter, remove the screen and rinse thoroughly with water. Then replace screen.

Connect one end of a garden hose (not included) to the water faucet — water supply not to exceed 100 psi (6.9 bar) and the other end to the water inlet of the jet machine. (See component identification drawings on next pages.) Use heavy duty 3/4" hose of no more than 50 ft. (15m) in length. If run without an adequate water supply, the pump will cavitate. Cavitation causes the pump to vibrate, causing damage to the pump. **Note:** Lack of water supply can lead to seal damage, causing a loss of pressure and will void the warranty to the pump.

Maximum temperature from the water source should not exceed 140°F (60°C). Using water hotter than 140°F (60°C) can cause damage to the pump and void the warranty. If jet is being used to clear ice blockages, see instructions on page 10.

Remove oil plug on top of pump and replace with dipstick supplied. Fill engine with oil. Refer to engine manual for quantity.

Hose Selection Guide

Select the proper hose diameter for the line to be cleaned. When using new hose, run water through it to clean it out before attaching the nozzle.

Hose Size (ID)*	Pipe Size	Typical Applications
3/8" or 5/16" long to 7.938mm)	4" to 8" (9.925mm)	Floor drains, septic lines, (102mm to 203mm) runs
1/4" drains, outs	2" to 4" (6.350mm)	Kitchen sinks, laundry clean (51mm to 102mm)
1/8" sinks, bends	1-1/2" to 2" (3.175mm)	Small lines, bathroom (38mm to 51mm) tight

* Inside Diameter

When selecting hose size, consider that pressure is lost as the water travels down the length of the hose. As the length increases, the pressure decreases. In addition, the smaller the diameter of the hose, the greater the loss of pressure per foot will be. As an example, at 2 GPM (.13L/sec) a 1/4" (6.350 mm) hose will lose 180 lbs. (12.4 bar) of pressure over 100 ft. (30.5m) of hose, yet

COMPONENT IDENTIFICATION AND USE
DRAIN CLEANING

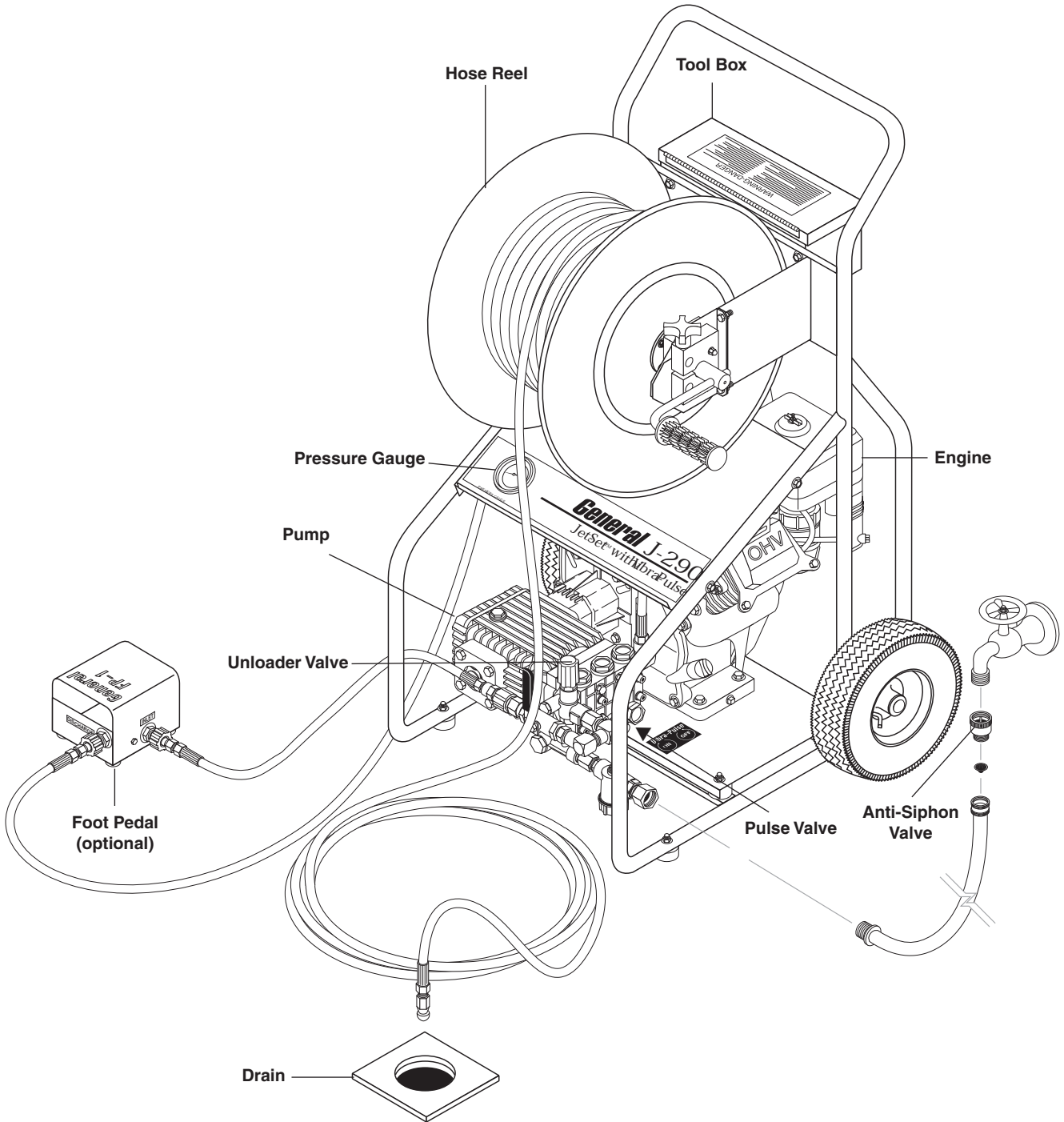

COMPONENT IDENTIFICATION AND USE DRAIN CLEANING THROUGH ROOF VENT

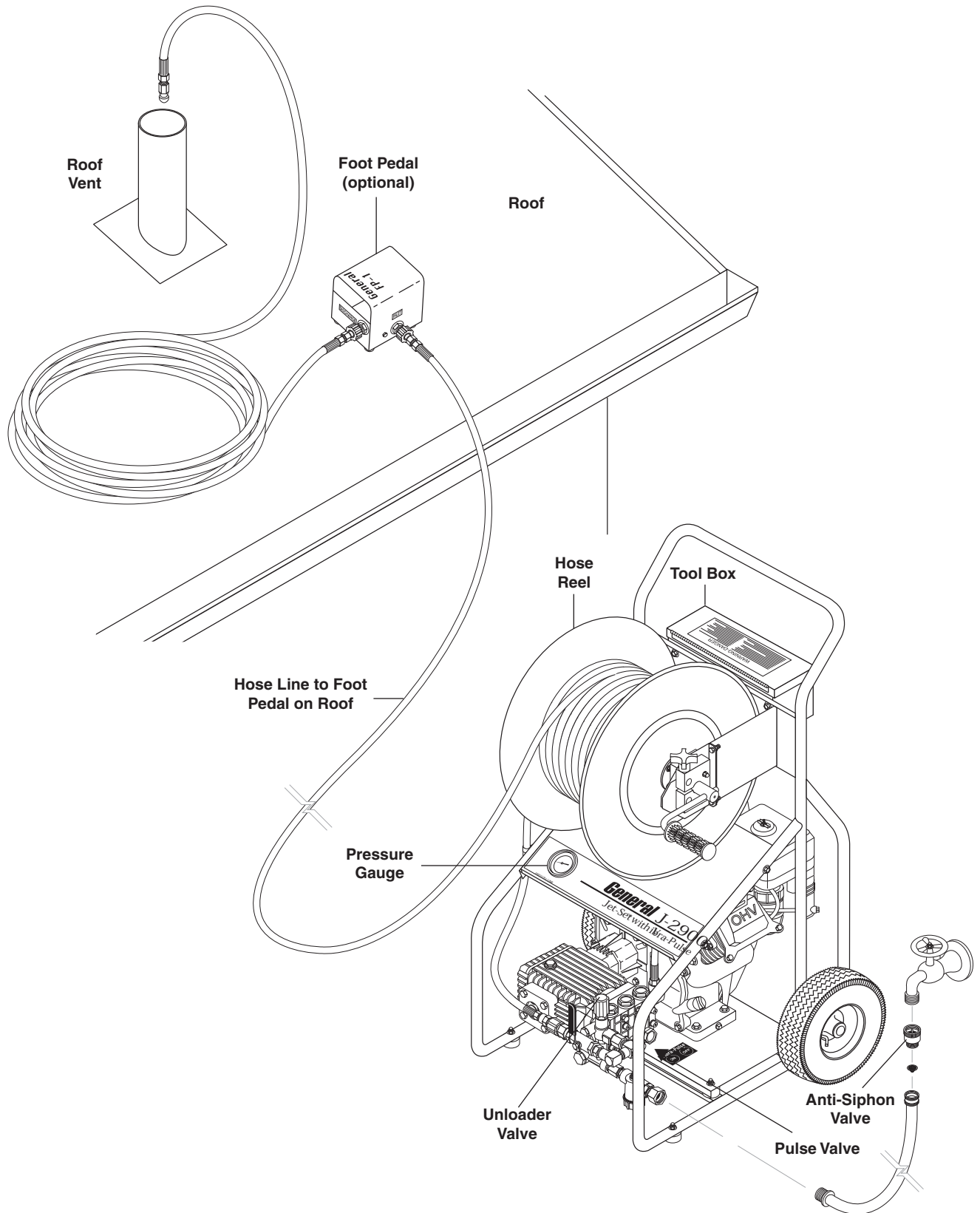

a 3/8" (9.925mm) hose will only lose 25 lbs. (1.7 bar) of pressure over the same length and at the same flow rate. At 4 GPM, a 3/8" hose will lose 90 lbs. (6.2 bar) of pressure over a 100 ft. (30.5m) length. The gauge reflects pressure from the pump only, not pressure at the end of the hose. It is important to select the largest possible hose size in order to have as much pressure as possible at the end of the hose.

Hoses of the same diameter may be coupled together using the CC-1 coupling, but it is not recommended for use in lines smaller than 8" (203mm) in diameter. The long length of the hose connectors and coupling together can get caught in bends in the line.

Coupling two different size hoses can be done through the spray wand trigger or foot pedal.

It is not advisable to have two different hose sizes coupled in a drain line. There is a tremendous loss of pressure when combined, aside from the difficulty of getting around bends.

The 3/8" (9.925 mm) and 1/4" (6.350 mm) hoses may be attached to the fitting in the core of the hose reel using the swivel at one end of the hose. The 3/8" hose may also be attached directly to the accessory outlet by using a twist connect. The 1/4" and 1/8" (3.175mm) hoses may be connected directly to the accessory outlet if an adapter fitting (AD-1 or AD-2) is used between the hose and quick connect. Adapters may be ordered separately.

Often, the 1/8" hose is used in conjunction with the spray wand trigger to give the operator finger tip control. Remove the spray wand from the trigger and attach the 1/8" hose using the AD-3 adapter.

A foot pedal FP-1 valve is available that can be used as a safety shut-off valve for all hose sizes. See foot pedal section for installation and operating instructions.

Nozzles

A number of types of nozzles are available for drain cleaning. Each has a different spray pattern. Some nozzles may have a hole in the front to cut through the stoppage. All will have holes in the back to drive the hose down the line and clean the walls of the pipe. A tight spray pattern (15°) has more driving power for long runs, a wide spray pattern (40°) does a better job of cutting the grease off the walls of the pipe. A combination of nozzles may be required to clear a line. Always turn off the machine and shut off valve before changing nozzles.

Make sure the nozzle you are using matches the pump size. A 3000 psi (207 bar) pump requires a different nozzle orifice than a 1500 psi (104 bar) pump. Mismatching nozzles with pump size will either cause too little pressure which may not clear the drain, or too much pressure which may damage the machine.

Check nozzles before and after each use for clogged holes which can cause pressure to increase to dangerously high levels and damage the pump. A clogged hole can be cleared by simply using the NCT Nozzle Cleaning Tool.

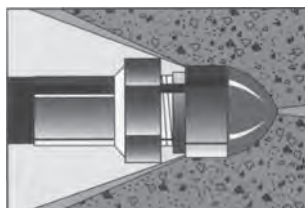

Powerful penetrating nozzle cuts through grease and ice.

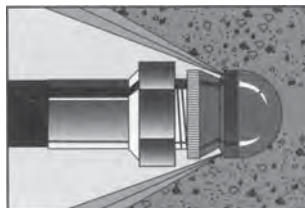

Wide spray flushing nozzle cleans inside of pipe thoroughly.

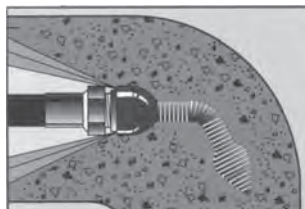

Spring leader nozzle gets hose around tight bends and P-traps

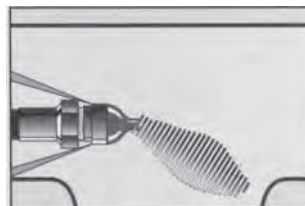

Downhead nozzle takes hose down Tee's and around difficult corners.

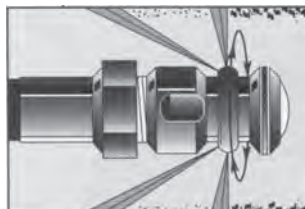

Rotary nozzle scours walls of pipe crystal clear

NOZZLE SELECTION GUIDE

	"1/8""	"1/4""	"3/8""
15o No Forward Jet	31	41	51
15o w/Forward Jet	32	42	52
30o No Forward Jet	33	-	-
40o No Forward Jet	-	44	54
Spring Leader (JNSL)	4	5	6
Rotary Nozzle	-	4	-
** Rotary Nozzles can be adapted to 1/8"" and 3/8"" hose using AD-3 or AD-4 adapters"			

Use the nozzle selection guide to determine what nozzle you will need for various applications. Example: If a nozzle is stamped #22, it is a JN-22, 15° rearjets, 2 GPM (.13L/sec) @ 1500 psi (104 bar) with a forward cutting jet. Spring leader nozzles and down head nozzles are special nozzles to help aid hose travel through the pipe when there are alot of curves and bends.

Rotary Nozzles

Rotary nozzles are useful as a finishing tool. After the line has been cleared, you may switch to the rotary nozzle to more thoroughly clean the walls of the pipe. Use these nozzles only in a predominantly straight run since they are longer than regular nozzles and may get caught in tight bends.

Pre-Operation Checklist

- ___ Be sure you understand all safety precautions and have been trained to use the machine.
- ___ Wear goggles or a face shield to protect your eyes from spray and from any product of the spray.
- ___ Wear gloves, rubber boots and other protective clothing as required.
- ___ Be sure you understand all safety precautions for the detergent use.
- ___ Check the labels of any substance you will spray. If the label recommends any antidote or treatment, be ready to use it.
- ___ Check that all lines and hoses are clear.
- ___ Check that the machine is connected to an adequate water supply and that the water supply is on.
- ___ Check that traffic has not made the hose weak, worn or damaged. Check the hose for pinching or kinking.
- ___ Replace any damaged hose.
- ___ Tighten all fluid connections securely.
- ___ Check gasoline and oil level of engine. See enclosed manufacturer's manual for engine and oil types.

OPERATING INSTRUCTIONS

- Read engine warning and operating instructions. Failure to follow instructions can cause serious injury and damage to equipment. Be familiar with all pre-operation checklists.
- Check all hoses for wear and damage. Tighten all connections securely.
- Check oil level of pump.
- Check engine fuel and oil levels.
- To begin, turn the water faucet on fully and purge air from system.
- Insert end of the jet hose 2 to 3 feet into the drain line. Then turn the valve on.

Warning: *Never point the end of the jet hose at a person while operating.*

Gas Engine Start-Up

1. Make sure that the ball valve is turned on and water is flowing.
2. Turn fuel valve to the open position.
3. Move choke lever to the closed position. **Note:** Do not use choke if engine is warm or ambient air temperature is high.
4. Move throttle lever to the midpoint position.
5. Turn the engine switch to the ON position.
6. Pull the starter grip lightly until resistance is felt, then pull briskly.
7. As the engine warms up, gradually move the choke lever to the open position.
8. Position the throttle to the desired engine speed.

Vibra-Pulse

Pulsation makes the hose vibrate, helping the jet go longer distances and around tight bends easier.

The pulse control valve is located on the front of the pump. Simply turn the valve on to engage the pulse.

The pulse causes a pressure drop when it's engaged. The pulse is most effective in a 1/8" hose. You'll note less vibration with a 1/4" hose and almost none with a 3/8" hose. However the pulse is still effective, causing the water to burst from the nozzle hundreds of times per second.

If you are still having difficulty getting a hose around a tight bend, switch to a smaller diameter hose.

Turn the pulse off before turning machine off.

Shut Down Instructions

After drain cleaning or spray washing is completed, run clear water through the system. Always leave ball valve in open position when turning off engine. Reduce engine to idle, turn off engine and then be sure to turn off fuel valve. Turn off water supply and drain as much water from pump as possible. Remove water supply hose from inlet. If you are in a cold climate, see Freeze Protection.

Cart-Reel™ and Handy-Reel

Use the Cart-Reel™ or Handy-Reel when clearing inside drain lines with the gas jet in order to use the high pressure jet without the danger of fumes in the building. Position the reel at the drain site. Connect the hose from the jet machine to the inlet on the reel. Select and attach a nozzle to the hose on the reel. Put the hose 2 to 3 ft. into the drain line. Open the ball valve on the reel. Follow the start up procedures.

Foot Pedal (Optional)

The foot pedal is used with any jet manufactured by General (see pages 6 or 7). It interrupts the flow of water between the pump and the nozzle while leaving both hands free to guide the hose. The pump will continue to run in by-pass mode. Do not leave pump in by-pass for more than a few minutes or the pump can be damaged. (See Regulating Pressure Unloader).

The foot pedal may be hooked up either at the machine or remotely at the drain site. To use the foot pedal at the machine, remove the hose going to the swivel on the hose reel and attach it to the inlet side of the foot pedal. Then, connect the accessory hose (6AHW) between the outlet of the pedal and the swivel on the hose reel. Some jet models may need the added length of the accessory hose on the inlet side of the pedal.

For remote hookup, pull the hose from the hose reel to the drain site. Attach the hose to the inlet of the pedal. The pedal is designed for 3/8" hose fittings. If using a 1/4" hose, use the AD-1 as well. Then attach the smaller hose (1/8" or 1/4") to the outlet side of the pedal. Use the smaller hose to clear the drain line.

Ice Blockages

High pressure water can be used to clear an ice blockage. A 3000 psi (207 bar) gas jet can clear a 4" (102mm) line at an approximate rate of one foot per minute. The smaller electric jet will take twice as long. Ambient air temperature will effect these times. Use a 15° nozzle with a forward jet. DO NOT allow the incoming water supply to exceed 140°F (60°C) or it could cause damage to the pump. Remember to follow the cold weather precautions found in the freeze protection section.

Spray Wand (Optional)

Follow the same procedures listed previously for safety, set-up, operation and maintenance. To operate the spray wand, connect the high pressure hose and trigger to the machine. Turn on the water supply, then squeeze the trigger to purge air from the system. Continue to squeeze trigger as you start the machine.

Use caution when pressure washing. Wear goggles and rubber gloves and boots. Analyze angle of spray and anticipate angle of back splash. Do not point spray at anyone including yourself. Do not put your hand in front of water spray. It can penetrate the skin and cause a need for amputation. It is best to start at a 45° angle at a 7 to 10 ft. (2 to 3m) distance from object to be cleaned. Direct spray at close range can be powerful enough to cause damage.

NOTE: Typical industry standard stipulates you hold the high pressure spray nozzle approximately 6-8" from the surface to be cleaned. When cleaning with a detergent, apply from bottom up with an even left to right movement.

Rinse from top down with a similar motion. This will help reduce potential streaking. Always apply soap to a dry surface. This will enhance penetration and detergent cling and reduce dilution of detergent with an already wet surface.

If you have the dual-lance wand (optional with the J-2900 and J-2000) you may draw detergents through the spray wand in conjunction with the detergent injector mounted on the machine. First set up the detergent injector system (see Detergent Injector).

Then simply turn the knob on the wand counterclockwise so that water is flowing through the wide spray nozzle. To spray water only, turn the knob to the clockwise position so that the water flows through the narrow spray nozzle.

The spray wand option with the other jets may also be used to spray detergent. To do so, simply turn the nozzle on the end of the wand counterclockwise. As the spray widens, more of the detergent will be drawn through the wand. Turn the nozzle clockwise to reduce the detergent flow and narrow the water spray pattern and return to high pressure.

Detergent Injector (Optional)

The detergent injector is an option with the J-2900 and J-2000 and can be attached to the free end of the ball valve. Do not attach detergent injector to the inlet side of the pump. Detergents can damage pump.

To use the detergent injector, attach one end of siphon hose to the injector and put the filter end in the detergent solution. Be sure the end of the hose is at the bottom of the container or bucket. Some models have adjustable valves to control the amount of detergent drawn through the hose.

Remember: Do not use corrosive material. See warning previously listed.

Regulating Pressure Unloader

The machine is equipped with a regulating pressure unloader to prevent pressure overload in the event that the nozzle is plugged or the ball valve or trigger is shut off. When the machine is in the by-pass mode, the pump will continue to run. However running in by-pass mode for extended periods will cause damage to the pump; no more than 5 minutes with the J-2900 and J-2000 pump. Excessive temperatures will damage the pump and void the warranty.

The machine also comes with thermal overload protection. When water temperature in pump increases to 140°F (60°C), the thermal relief valve will release hot water and allow cool water to enter pump from fresh water supply.

To adjust unloader, loosen lock nut and turn the knob clockwise to increase pressure and counterclockwise to decrease pressure. **Caution:** Do not overtighten unloader. Tighten lock nut after adjustments are made.

Freeze Protection

To protect your machine from severe damage caused by water freezing inside the components, it is important to winterize it whenever it is subjected to freezing temperatures.

The best way to protect the system is to keep it out of the cold. Barring that, the next best way is to flush the system with anti-freeze. To do so, simply attach a short garden hose (not to exceed four feet) to inlet on the pump and put other end into the anti-freeze container. Be sure to remove the nozzle from the hose. Turn the machine on to draw anti-freeze into the system. When anti-freeze flows out of the end of the hose, turn the machine off. Connect high pressure hose and trigger and follow above procedure. Cycle trigger on/off so that the anti-freeze will flow into unloader and injector section of machine.

When preparing to operate equipment the next time, remove the anti-freeze. To do so, reconnect water source, turn pump on and direct flow of anti-freeze back into container. Be careful not to dilute anti-freeze with incoming water supply. Anti-freeze, if kept relatively undiluted can be used again and again.

Hoses can also be protected from freezing by using compressed air to clear them of residual water. Remember to remove nozzle from jet hose and hold trigger of spray wand in open position.

MAINTENANCE

Regular inspection is the key to preventing breakdowns and prolonging the life of the equipment. Follow this simple procedure religiously.

DAILY

Check that the water supply is adequate.

Check that the nozzle on the spray wand is not clogged or worn out.

Check that the PUMP OIL LEVEL is within operating range on dipstick or sight glass.

Check that the engine FUEL LEVEL is full.

Check that the ENGINE OIL LEVEL is within operating range on dipstick.

Check the INLET FILTER.

WEEKLY

Check the PRESSURE HOSE for wear and damage. Damaged hose can be repaired at a local service dealer or by your equipment dealer.

Check the FUEL FILTER for dirt and sediment.

Check the AIR FILTER for dirt. Clean and replace as required.

Maintenance Schedule

Use the following maintenance schedule at the stated intervals or when your routine turns up a problem.

Shut off gas engine before attempting any repairs or maintenance.

ITEM TO BE SERVICED	MONTHS OR HOURS OR SERVICE				
	1st Month or 20 Hours	1st 3 Months or 50 Hours	Every 3 Months or 50 Hours	Every 6 Months or 100 Hours	Every Year or 500 Hours
Pump Crankcase Oil Change*		X			X
Engine Oil Change**	X			X	
Air Filter Cleaning		X	X		
Fuel Filter Change				X	
Spark Plug Change				X	
* Use SAE 30W Non-Detergent Motor Oil to full mark on dipstick or to dot on sight glass.					
** Refer to engine manufacturer's specifications for correct oil viscosity when adding to engine oil.					

EXPLODED VIEW
J-2900

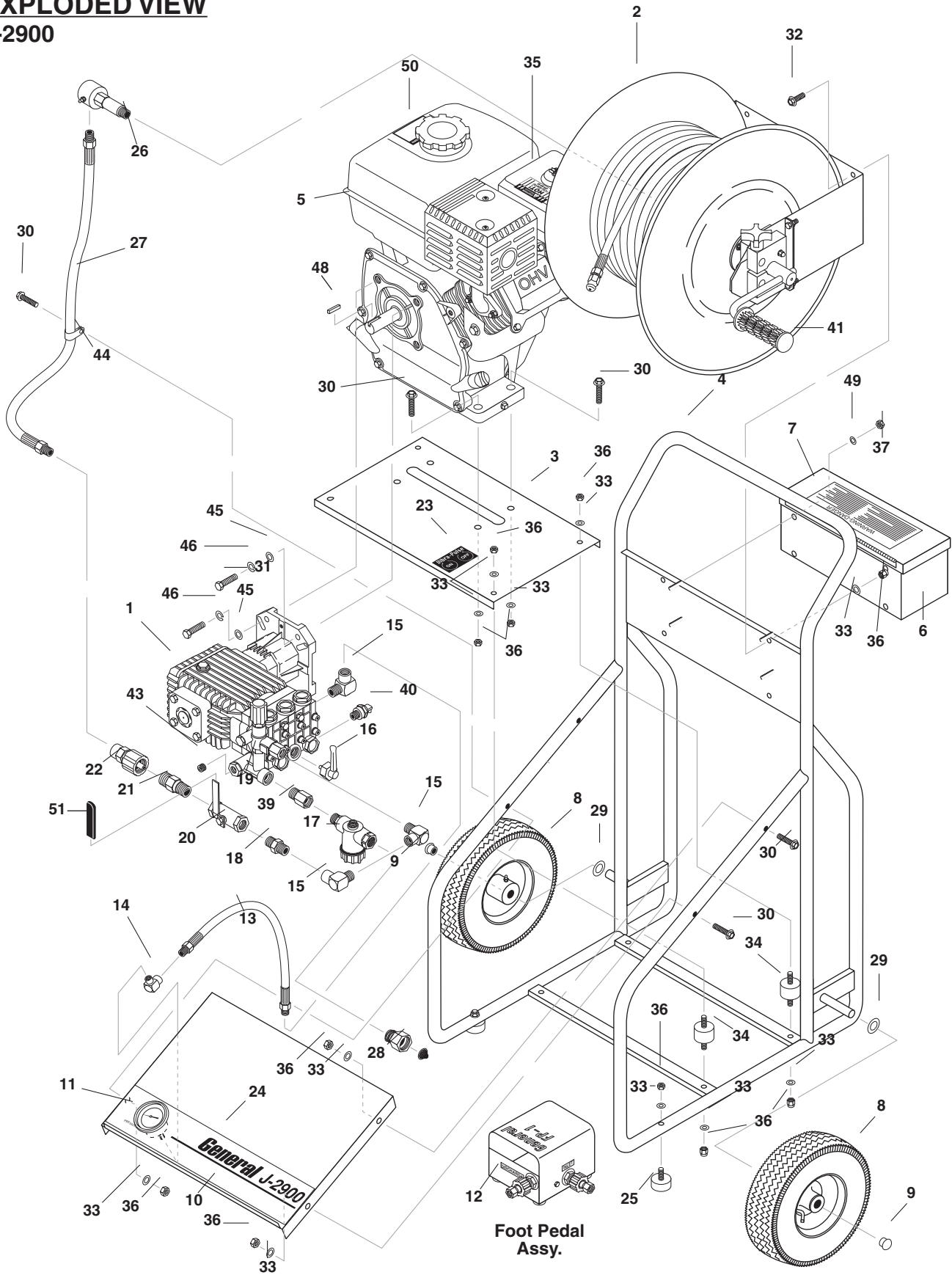

EXPLODED VIEW PARTS LIST J-2900

ITEM	PART NO.	DESCRIPTION	QTY	ITEM	PART NO.	DESCRIPTION	QTY
1	5-23120	Pump, General TX1510G8	1	25	2-01015	Bumper, Rubber 1", w/Bolt	2
	90-80951	▲ Oil 30WT Det /Gal.	1	26	4-027510282	Swivel, 1/2" x 1/2" Pipe	1
2	4-02751015	Assy Hose Reel, J-2900	1	27	4-02037834	Hose, 3/8" x 34", 3/8"MS x 3/8"MSW	1
3	95-07103151	Base, Engine Mount, J-2900	1	28	2-10942	Swivel, 1/2" MP x 3/4"GHF, w/Strainer	1
4	95-07103150	Weld Frame J-2900	1	29	90-4005	Washer, 5/8" Flat, SAE	2
5	5-010721	Engine Gas, 13 HP Honda	1	30	90-19714	Bolt, Hex, 5/16" x 1-1/2" FLG	8
	11-1005	▲ Tag, Caution No Oil/Engine	1	31	90-1018	Bolt, Hex, G5 3/8" x 16 x 1-1/2"4	
6	95-07103208	Box, Tool, Orange	1	32	90-19713	Screw, 5/16" x 3/4" Whiz Loc	4
7	11-0113	Decal, JSG Warn Danger	1	33	90-4001	Washer, 5/16" Flat, SAE	22
8	4-0303	Wheel Pneu-10x4.0 5/8" HUB	2	34	2-01016	Mount, Rubber	4
9	90-200422	Cap Axle 5/8", BLK	2	35	10-02025A	Label, Hot/Caliente	1
10	95-07103152	Sheet, Fab Panel, J-2900	1	36	90-2001	Nut, 5/16" ESNA, NC	22
11	4-050351	Gauge, Panel Mount, Glycerin	1		97-504	▲ Lit Form, Warranty Registration	1
12	26-FP-1	Pedal, Foot (Optional)	1		8.914-324.0 / 97-6117	▲ Manual, General Jet Set	1
13	4-02011413	Hose, 1/4" x 13.25", 1/4"MS x 3/8" M	1	37	90-2000	Nut, 1/4" ESNA, NC	1
14	2-1018	Elbow, 1/4", Fem	1	38	2-30062	▲ Anti-Siphon Valve	1
15	2-0031	Elbow, 3/8" Street, P/N, TF, C3409 x 6	3	39	2-1100	Adapter, 1/2" x 1/2"	1
16	1-100316	Valve, Jutter, EZ Pump	1	40	2-30082	Pump Protector, 1/2"	1
17	2-1923	Strainer, 1/2 PA, Inline Plastic	1	41	2-01101	Grip, 1" Handle	1
18	2-0006	Nipple, 3/8" x Hex Steel, P/N, C3069 x 6	1	42	2-00681	▲ Bushing, 1/2" x 3/8" Steel	1
19	5-3025	Unloader, PA 8GPM@3600 PSI VB75K	1	43	2-1044	Plug, 1/8" Countersunk	1
20	2-30002	Valve, 3/8" Ball, Steel	1	44	2-9016	Clamp, Screw	1
21	2-2115	Plug, 3/8" MPT x MZZ, Screw Type	1	45	90-4002	Washer, 3/8" Flat	4
22	2-2113	Coupler, 3/8" Female, Screw Type 7640	1	46	90-4009	Washer, 3/8" Lock, Split	4
23	11-10160	Label, Vibra-Pulse	1	47	2-01442	▲ Plug, Garden Hose Adapter	1
24	11-202900	Decal, 2900	1	48	95-07141121	Key, .247 Sqaure x 2-1/8"	1
				49	90-4000	Washer, 1/4" Flat, SAE	1
				50	10-02029	Label, Danger Cool Engine	1
				51	2-01209	Cover, Handle General	1
						▲ Not Shown	

EXPLODED VIEW
J-2000

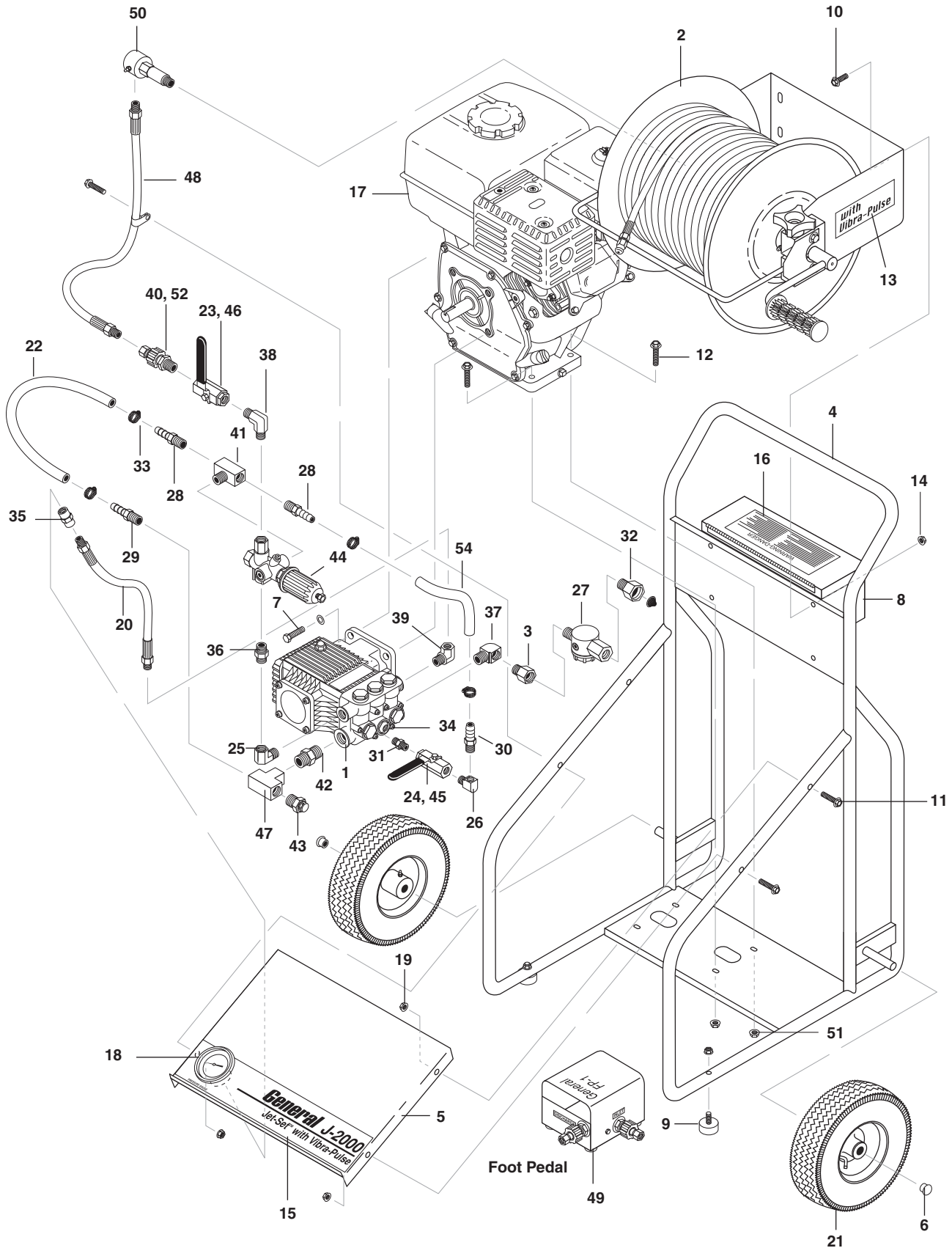

EXPLODED VIEW PARTS LIST J-2000

ITEM	PART NO.	DESCRIPTION	QTY	ITEM	PART NO.	DESCRIPTION	QTY
1	5-2255	Pump AR XTV3G20D-F7C44	1	29	2-10865	Nipple Hose 1/2" NPT x 1/2"H BR	1
	90-8051	▲ Oil 30WT Det /Gal.	1	30	2-008802	Nipple Hose 1/4" NPT x 1/2"H PL	1
	11-1002	▲ Decal Warning Plug	2	31	2-0004	Nipple Hex 1/4" x 1.45" 5000 WP	1
	11-3104	▲ Tag, Water Temp to Pump	1	32	2-10942	Swivel, 1/2" MP x 3/4" GHF	1
2	4-02751016	Hose Reel, J-2000	1		2-30062	▲ Anti-Siphon Valve	1
3	2-1100	Adapter, 1/2" x 1/2" Pipe	1	33	2-9002	Clamp, Screw, #6	4
4	95-07103230	Weld Frame J-2000	1	34	83-1260162T	Plug Manifold 1/4" Gas Tap	1
5	95-07103231	Sheet Fab Panel J-2000	1	35	2-0022	Coupler, 1/4 Pipe	1
6	90-200422	Cap Axle 5/8", BLK	2	36	2-0006	Nipple, Hex 3/8" x 1.45"	1
7	90-10053	Bolt Hex G5 5/16"-24 x 1-3/4"	4	37	2-1024	Elbow ST 90 1/2" 1000WP BR	1
	90-4008	Wshr LK 5/16"	4	38	2-00270	Elbow 90 3/8" MNPT 3900BR	1
8	95-07103208	Box, Tool, Orange	1	39	2-00272	Elbow, Street 1/4" x 3/8" Steel	1
9	2-01015	Bumper Rubber 1" w/Bolt	2	40	2-2113	Coupler 3/8" Female Screw Type 9640	1
10	90-19713	Bolt Hex, 5/16" - 18 x 3/4" FLG	4	41	2-1038	Tee 3/8" Branch, Male	1
11	90-19709	Bolt Hex, 1/4"-20 x 1-1/2" FLG	4	42	2-1007	Nipple Hex 1/2" x 1.5" 3900WP BR	1
12	90-19714	Bolt Hex 5/16"-18 x 1-1/2" FL	4	43	2-30082	Pump Protector, 1/2" PTP	1
13	11-1004	Decal w/Vibra Pulse	1	44	5-3210	Valve Unldr Yellow	1
14	90-2001	Nut Hex ESNA 5/16"-18 PL	4	45	2-30001	Valve Ball Steel 1/4"	1
15	11-202000	Decal, J-2000	1	46	2-30002	Valve Ball Steel 3/8"	1
16	11-0113	Decal, JSG Warn Danger	1	47	2-1032	Tee 1/2" NPT 1000WP BR	1
17	5-0104	Engine Gas, 5.5 HP Honda	1	48	4-02037822	Hose 3/8" x 22.5", 1 Wire, 3/8" MPT x 3/8" MPTS	1
	11-1005	▲ Tag, Caution No Oil/Engine	1	49	26-FP-1	Foot Pedal (Optional)	1
18	4-05021	Gauge Panel Mount Glycerin	1	50	4-027510281	Swivel 3/8" x 3/8"	1
19	90-2000	Nut Hex ESNA 1/4"-20 PL	4	51	90-2001	Nut, ESNA, 5/16"	4
20	4-02011211	Hose 1/4" x 11", 1/4" MS x 3/8"M	1	52	2-2115	Plug, 3/8" x 22mm	1
21	4-0303	Wheel Pneu-10 x 4.0 5/8" HUB2		53	97-504	▲ Lit Form Warranty Registration	1
22	4-02110000	Hose 1/2"	15.5"		8.914-324.0 / 97-6117	▲ Manual, General Jet Set	1
23	2-01209	CVR Handle General Jet	1	54	4-02110000	Hose, 1/2"	9.25"
24	2-01210	CVR Handle VP-2000	1			▲ Not Shown	
25	2-0031	Elbow ST 90 3/8" 4500WP PL	1				
26	2-1022	Elbow ST 90 1/4" 1000WP BR	1				
27	2-1923	Strainer 1/2", Inline	1				
28	2-008801	Nipple Hose 3/8" NPT x 1/2"H PL	2				

**OPTIONAL HR-200W HANDY-REEL WITH FOOT PEDAL
EXPLODED VIEW & PARTS LIST**

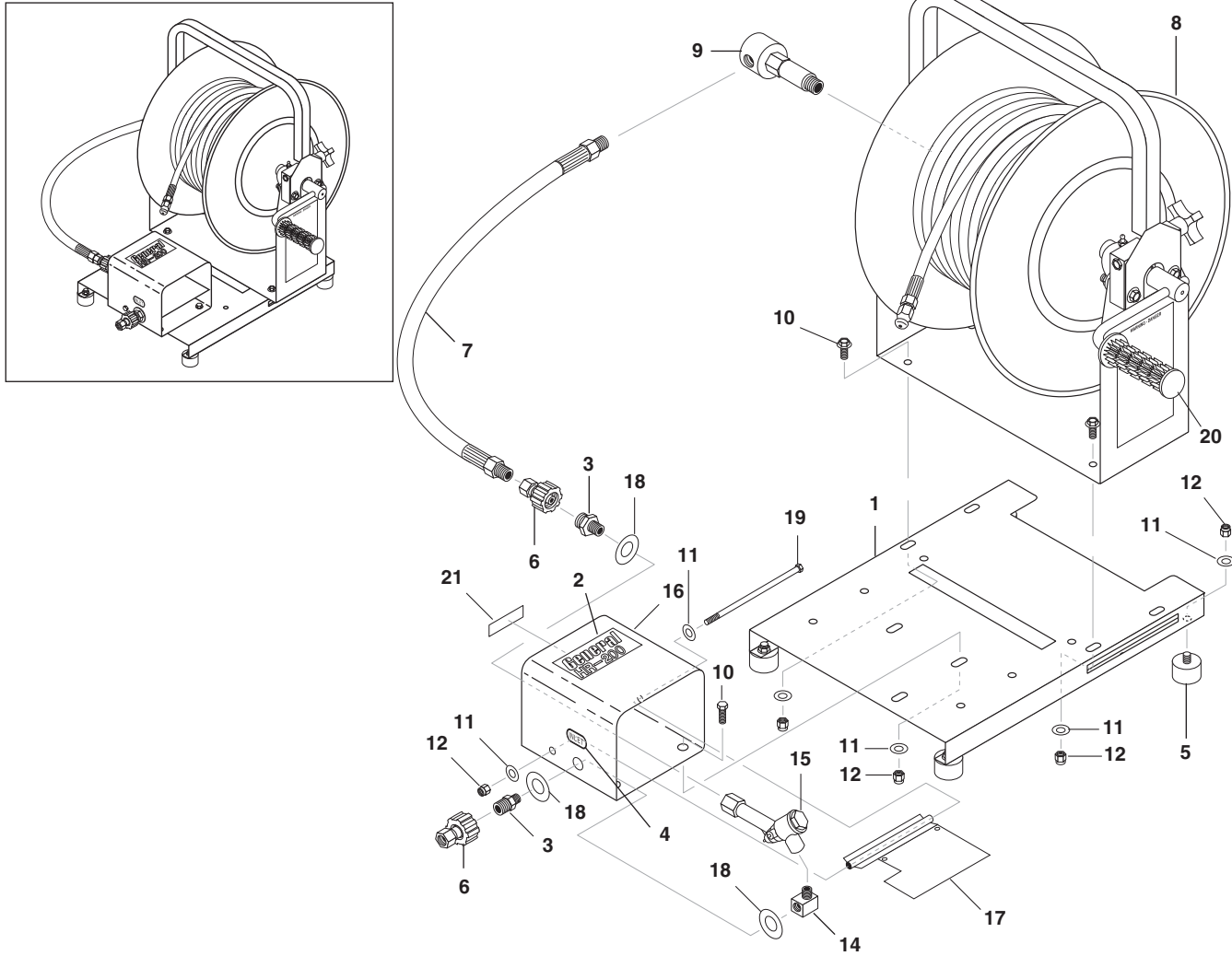

ITEM	PART NO.	DESCRIPTION	QTY
1	95-07103106	Bracket, Hose Reel Mount	1
2	11-20200	Label, HR-200	1
3	2-2116	Nipple, 1/4" x M22, Twist	2
4	11-1019	Label, Inlet	1
5	2-01022	Foot, Rubber	4
6	2-2113	Coupler, 3/8" Female Screw Type 7640	2
7	4-02037817	Hose, 3/8" x 17.5", 1 Wire, 3/8" MNPT(SLD) x 3/8" MNPT(SWL)	1
8	4-02751016	Hose Reel, 13" General Wire	1
9	4-027510281	Swivel, 3/8" x 3/8"	1
10	90-19713	Screw, 5/16" x 3/4" Whiz Loc	7
11	90-4001	Washer, 5/16"	13
12	90-2001	Nut, 5/16" ESNA	12
13	95-07103105	Hose Reel Guard	1

ITEM	PART NO.	DESCRIPTION	QTY
14	2-1022	Elbow, 1/4" Street	1
15	83-21008	Valve Assy, Complete	1
16	95-07103180	Cover, Welded Assy. Foot Valve	1
17	95-07103181	Plate, Fott Valve Assy	1
18	90-3096	Washer, 1/2" Flat	3
19	90-10124	Bolt, 5/16" x 6-1/2" HH, NC	1
20	2-01101	Grip, 1" Handle, Waffle	1
21	11-1010	Label, Discharge	1

CR-300 EXPLODED VIEW AND PARTS LIST

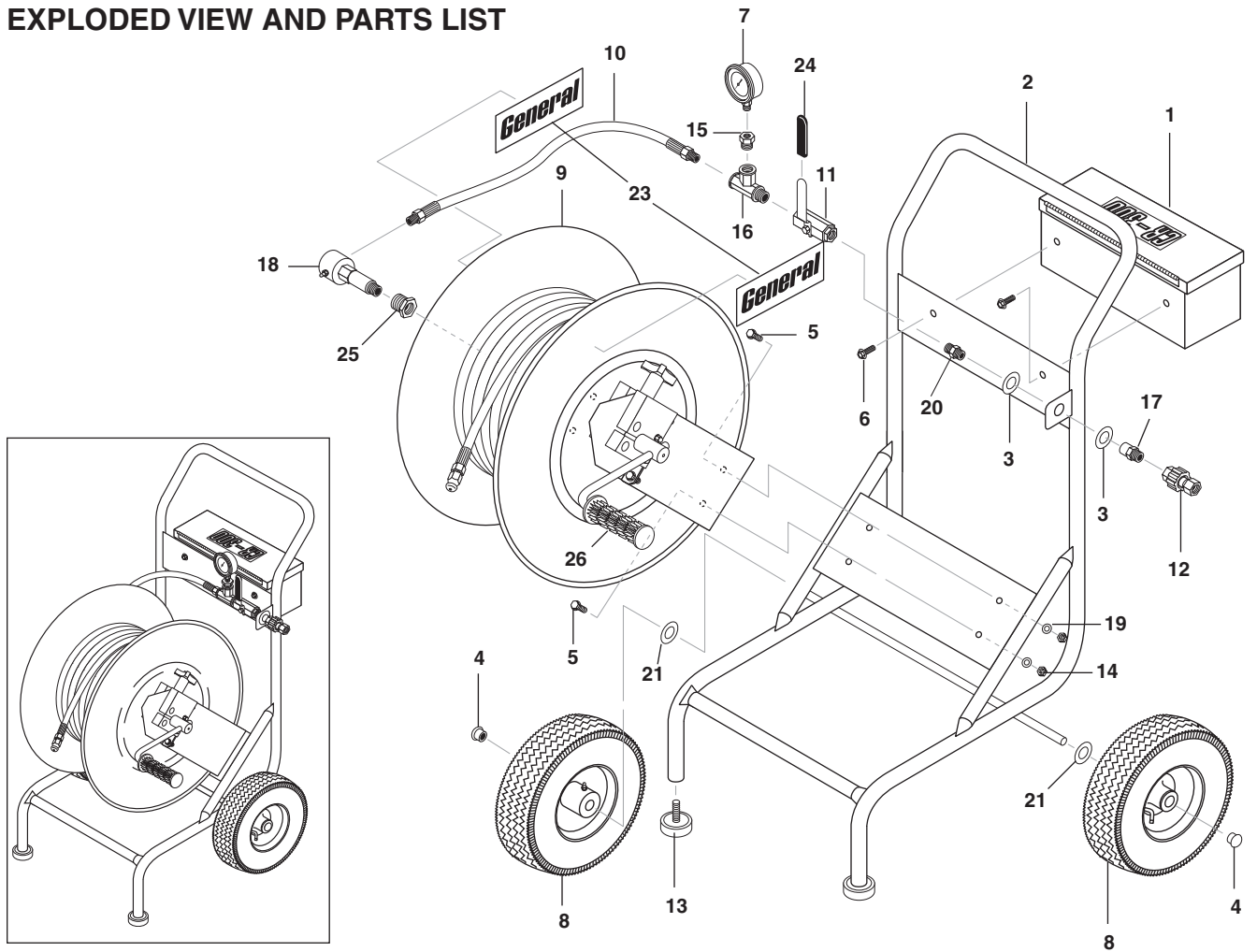

ITEM	PART NO.	DESCRIPTION	QTY
1	95-07103208	Assy, Tool Box, Orange	1
2	95-07103130	Assy, Frame, General CR-300	1
3	90-400712	Washer, 3/4" x 1-1/2", .102 THK Brass	2
4	90-200422	Cap, 5/8" Axle, BLK	2
5	90-19713	Screw, 5/16" x 3/4" Whiz	4
6	90-19711	Screw, 1/4" x 1/2" HH NC, Whiz Loc	2
	90-2000	▲ Nut, 1/4" ESNA	2
	90-4000	▲ Washer, 1/4" Flat, SAE	2
7	4-0502	Gauge, Pressure 0-5000 PSI	2
8	4-0303	Wheel & Tire Assy, 4" Tubeless Silver Rim, 5/8" Hub	2
9	4-02751015	Hose Reel, 18", General Wire	1
10	4-02047823	Hose, 3/8" x 23", 2 Wire 3/8" SMNPT x 3/8" SWMNPT	1
11	2-30002	Valve, 3/8" Ball, Steel	1

ITEM	PART NO.	DESCRIPTION	QTY
12	2-2113	Coupler, 3/8" Female Screw-Type 7640	1
13	2-01019	Foot, Rubber (Crutch)	2
14	90-2001	Nut, 5/16" ESNA	4
15	2-00682	Bushing, 3/8" x 1/4" Steel	1
16	2-0045	Tee, 3/8" Street	1
17	2-2114	Plug, 3/8" FX M22, Twist Coupler	1
18	4-027510282	Swivel, 1/2" x 3/8"	1
19	90-4001	Washer, 5/16" Flat	4
20	2-0006	Nipple, 3/8" Hex Steel	1
21	90-4005	Washer, 5/8" Flat, SAE	2
22	11-1009	Label, CR-300	1
23	11-0105	Label, General Logo	2
24	2-01209	Cover, Handle, General, Jet LG1	1
25	2-00681	Bushing, 1/2" x 3/8", Steel	1
26	2-01101	Grip, 1", Handle, Waffle	1

▲ Not Shown

PUMP MODEL TX1510G8
JET SET MODEL J-2900, PART #5-23120

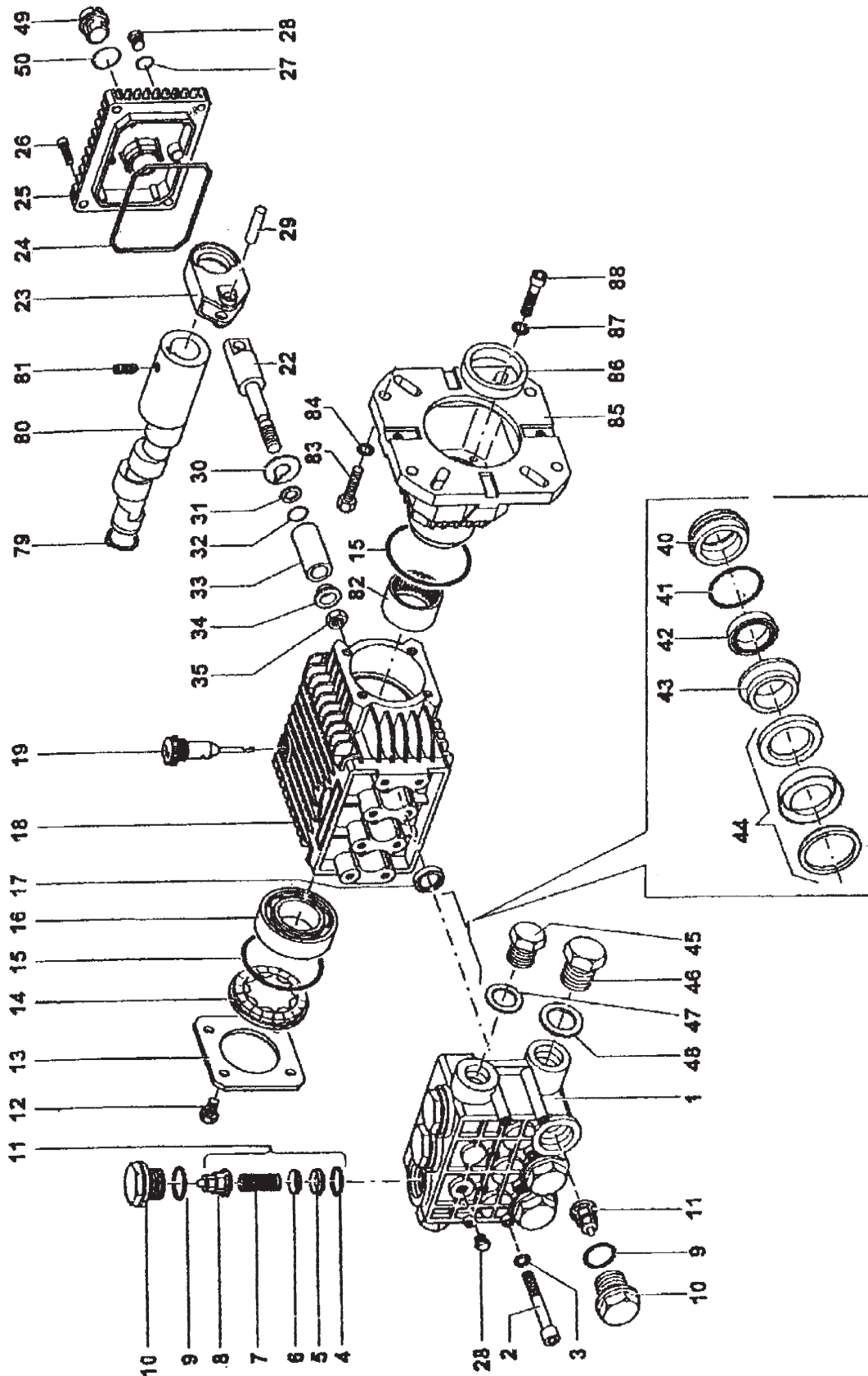

PUMP MODEL TX1510G8 JET SET MODEL J-2900, PART #5-23120

ITEM	PART NO.	DESCRIPTION	QTY
1	1-63120041	Manifold, 15mm	1
2	1-99319200	Screw, M8 x 65	8
3	1-96701400	Lockwasher, M8.4	8
4	1-90384100	O-Ring (Kit 123)	6
5	1-36200366	Valve Seat (Kit 123)	6
6	1-36200176	Valve (Kit 123)	6
7	1-94737600	Spring (Kit 123)	6
8	1-36202551	Valve Cage (Kit 123)	6
9	1-90384700	O-Ring (Kit 124)	6
10	1-98222600	Valve Cap (Kit 124)	6
11	1-36711501	Valve Assembly (Kit 123)	6
12	1-99180700	Screw, M6 x 10	8
13	1-50150074	Bearing Cover	1
14	1-44211801	Oil Level Indicator	1
15	1-90409700	O-Ring	2
16	1-91832900	Ball Bearing	1
17	1-90161400	Oil Seal (Kit 159)	3
18	1-63010022	Crankcase	1
19	1-98210300	Oil Dip Stick	1
22	1-63050066	Plunger Guide	3
23	1-63030022	Connecting Rod	3
24	1-90392000	O-Ring, Cover	1
25	1-63160022	Rear Crankcase Cover	1
26	1-99183700	Screw	4
27	1-701013	O-Ring	1
28	1-98204100	Plug, 1/4" G	2
29	1-97733500	Connecting Rod Pin	3
30	1-96707500	Finger Washer	3
31	1-660024	Anti-Extrusion Ring	3
32	1-701009	O-Ring	3
33	1-52040009	Ceramic Plunger, 15mm	3
34	1-44211570	Bushing	3
35	1-92221500	Nut, M8	3
40	1-63080070	O-Ring (Kits 162, 166)	3

ITEM	PART NO.	DESCRIPTION	QTY
41	1-90360800	O-Ring (Kits 166, 1667)	3
42	1-90260800	Seal, LP, 15mm (Kits 160, 166)3	
43	1-63216070	Int. Ring 15mm (Kits 164, 166)3	
44	1-90261200	Packing Assy., 15mm (Kits 160, 166)	3
45	1-98210000	Plug, 3/8" G	1
46	1-98217600	Plug, 1/2" G	1
47	1-96738000	Washer, M17.5	1
48	1-96751400	Washer, M21.5	1
49	1-63210051	Oil Level Indicator	1
50	1-90405100	O-Ring	1
79	1-90063500	Retaining Ring	1
80	1-63027765	Crankshaft, 6.5	1
	1-63028065	Crankshaft, 8	1
	1-63028465	Crankshaft, 10	1
81	1-99179000	Screw, M6 x 6	1
82	1-91856800	Roller Bearing	1
83	1-99334500	Screw, 3/8" x 1	4
84	1-96710400	Washer	4
85	1-10051822	Flange 1", Gas Engine	1
86	1-90169000	Oil Seal	1
87	1-96693800	Washer	4
88	1-99191200	Screw, M6 x 30	1

Crankcase Oil Capacity, 14 oz.

Torque Specs

Position	Ft./Lbs.	N-M
2	14.7	20
10	73.7	100
12	7.3	10
26	7.3	10
28	14.7	20
35	11.0	15
45	29.4	40
46	29.4	40
83	14.7	20
88	7.3	10

KIT NO.	123	124	159	160	162	164	166
ITEM NO'S INCLUDED IN KIT	4, 5, 6, 7, 8, (11)	9, 10	17	42, 44	40	43	40, 41, 42, 43, 44
NO. OF ASSEMBLIES	6	6	3	3	3	3	1
NO. OF CYLINDERS KIT WILL SERVICE	3	3	3	3	3	3	1

PUMP MODEL XTV3G20D-F7C44
JET SET MODEL J-20000, PART #5-2255 EXPLODED VIEW

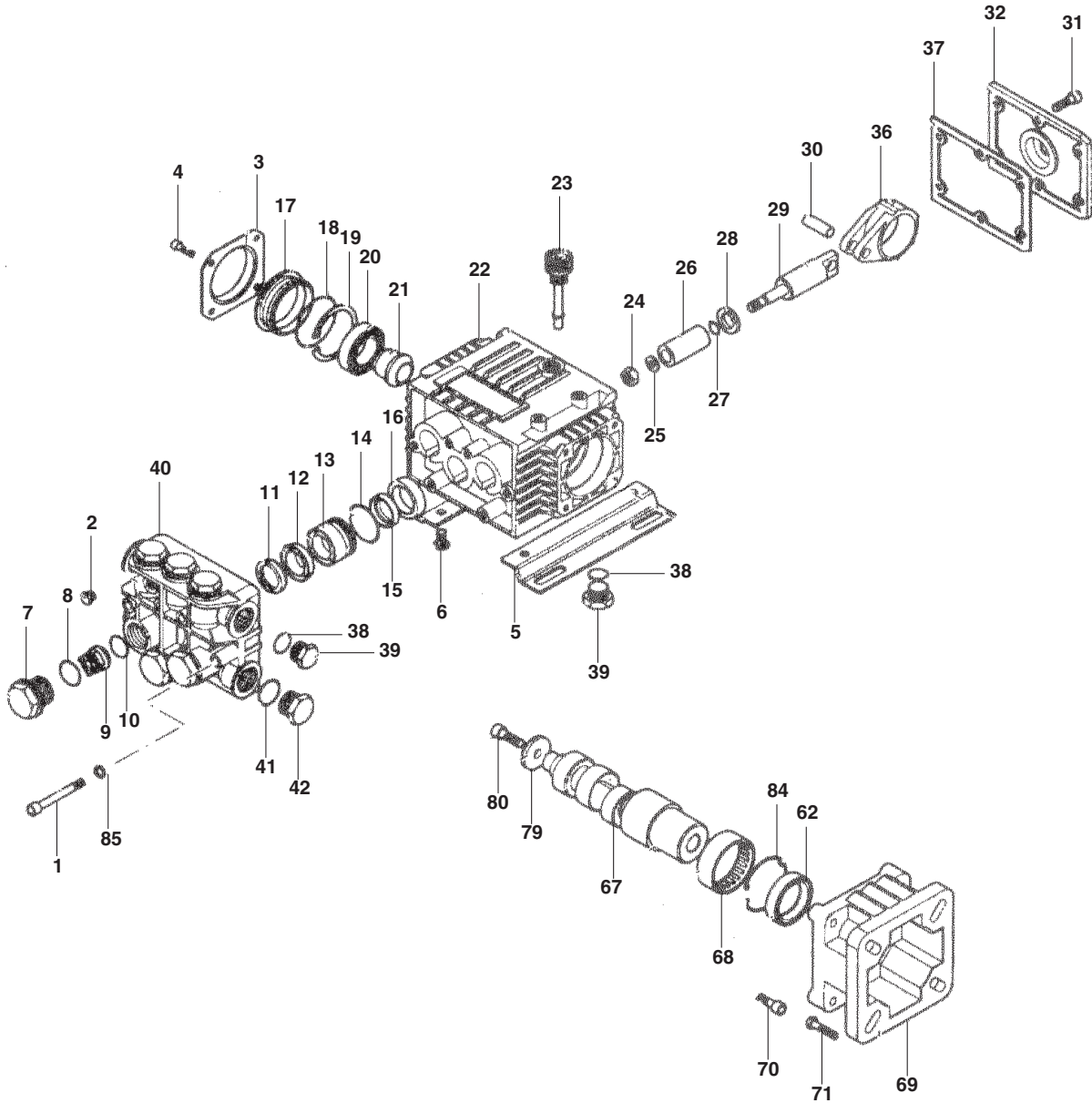

PUMP MODEL XTV3G20D-F7C44 PARTS LIST

ITEM	PART NO.	DESCRIPTION	QTY	ITEM	PART NO.	DESCRIPTION	QTY
1	83-680570	Head Bolt, TCEI M6 x 60 Brass	6	23	83-880130	Dip Stick	1
2	83-620301	Tap Plug, 1/8", G (Optional)	1	24	83-1260110	Screw M*	3
3	83-1321420	Side Cover	1	25	83-1260100	Washer, Copper, 8 x 13 x .5	3
4	83-1321780	Bolt TCEI M6 x 12	4	26	83-1260120	Piston Ø15	3
5	83-1263890	Base Plate	2	27	83-480480	O-Ring, Ø4.48 x 1.78	3
6	83-1260470	Mounting TE M8 x 10	4	28	83-1260091	Disc Separator	3
7	83-1260160	Cap, Valve	6	29	83-1260070	Piston Guide	3
8	83-960160	O-Ring, Ø17.86 x 2.62	6	30	83-1260080	Piston Pin, Ø _E 7 x 24	3
9	83-1269050	Complete Valve	6	31	83-1260760	Screw TCEI M5 x 20	6
10	83-880830	O-Ring, Ø15.54 x 2.62	6	32	83-1260030	Rear Cover, Low	1
11	83-1260140	Support Ring Ø15	3	33	83-1140450	O-Ring, Ø20.24 x 2.62	1
12	83-1260130	Packaging Gasket Ø15	3	34	83-1260250	Oil Indicator	1
13	83-1260151	Piston Guide Ø15	3	35	83-1260430	Snap Ring ZJ 25	1
14	83-1260420	O-Ring, Ø26.70 x 1.78	3	36	83-1320140	Con Rod, Bronze	3
15	83-1260440	Packaging Seal Gasket Ø15	3	37	83-1260040	Rear Gasket Cover	1
16	83-1260460	Piston Oil Seal 15 x24 x 5	3	38	83-740290	O-Ring, Ø14 x 178	3
17	83-1320320	Shaft Side Plug	1	39	83-880530	Oil Drain Tap Bolt 3/8" G	2
18	83-1320360	O-Ring, Ø47.35 x 1.78	1	40	83-1320020	Pump Head without Hole, 18mm, Brass	1
19	83-1260790	Circlip, Ø ₁ 52	1	41	83-180101	O-Ring, Ø17.5 x 2	1
20	83-1320370	Bearing, 25 x 52 x 15 6205	1	42	83-820360	Head Tap Bolt 1/2" G	1
21	83-1320330	Bushing	1				
22	83-1320010	Pump Body	1				

Kit 83-1860 OIL SEALS (E Ver)		Kit 83-1864 VALVES		Kit 83-1866 VALVE SEALS	
Pos.	Qty.	Pos.	Qty.	Pos.	Qty.
16	3	9	6	11	3
18	1	10	6	12	3
37	1			14	3
62	1			15	3

HOSE AND SPRAY GUN ASSEMBLY (OPTIONAL)

J-2000 EXPLODED VIEW AND PARTS LIST SWA-1500

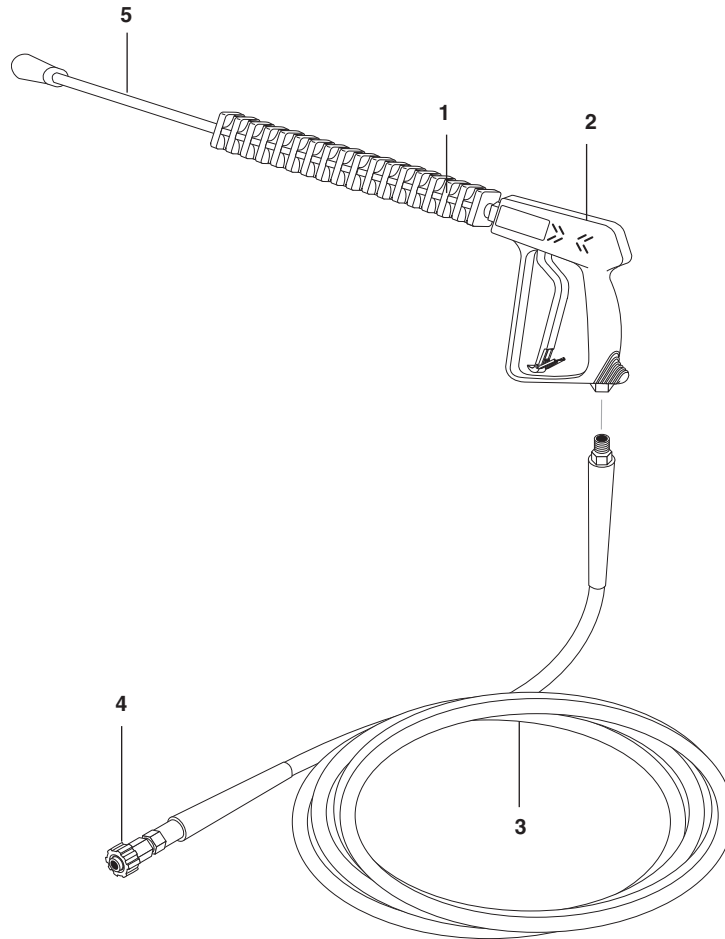

ITEM	PART NO.	DESCRIPTION	QTY
1	4-011148	Lance, 18" Molded Grip AL-3929.11	1
2	4-01246	Spray Gun, Shut-Off AP 1000	1
3	8.739-030.0	Hose, 3/8" x 25', 1 Wire, TS, Legacy, 50 x SW	1

ITEM	PART NO.	DESCRIPTION	QTY
4	2-2113	Coupler, 3/8" Female Screw Type 7640	1
5	4-2005	Nozzle Holder, Adjustable AL-TR9-4701.12	1
	4-01402515	▲ Nozzle Only, SA 1/4", MEG 1502.5	1

▲ Not Shown

HOSE AND SPRAY GUN ASSEMBLY (4-0111461B / 8.904-453.0)

J-2900 EXPLODED VIEW AND PARTS LIST SWA-3000

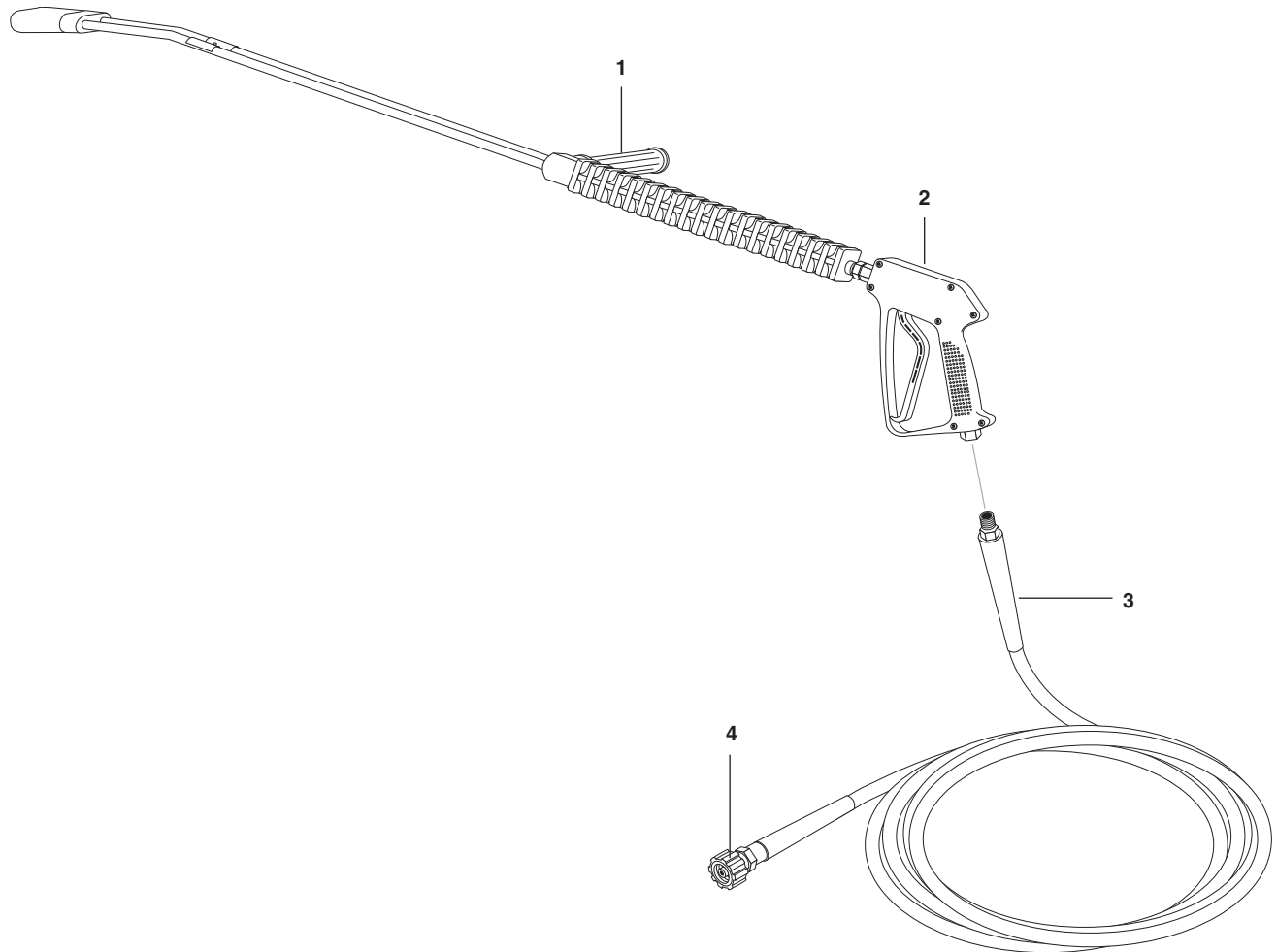

ITEM	PART NO.	DESCRIPTION	QTY
1	8.904-452.0	Wand, VP ARO, Soap Nozzle	1
	8.711-387.0	▲ Nozzle Only, 1/4" MEG 1504.5	1
	8.711-457.0	▲ Nozzle Only, H-1/4"-U-6540, VEEJet	1
2	8.711-348.0	Spray Gun, Shut-off AP 1000	1
3	8.739-031.0	Hose, 3/8" x 50', 1 Wire, Tuff-Skin, 3/8" MPT x 3/8" MPTS	1
4	8.707-182.0	Coupler, 3/8" Female, Screw-Type 7640	1

▲ Not Shown

TROUBLESHOOTING

These troubleshooting procedures cover pump malfunctions, delivery problems and charge system malfunction.

Warning: Before attempting any repairs or maintenance, make sure machine is shut off.

PROBLEM	POSSIBLE CAUSE	REPAIR
LOW PRESSURE	Worn or oversized nozzle	Replace worn nozzle. Check nozzle size.
	Clogged water and/or chemical inlet strainer	Clean or replace strainers.
	Worn or damaged piston cups	Replace piston cups.
	Worn or damaged inlet or discharge valve	Replace worn valve poppets or valve springs.
	Dirt or foreign particles in valve assembly	Remove any dirt particles.
	Air leak in inlet plumbing	Locate air leak. Re-seal connection or replace damaged port.
ROUGH OPERATION WITH LOSS OF PRESSURE	Restricted inlet plumbing or air leak in inlet plumbing	Replace clogged inlet fittings. Check supply hose and ensure adequate water supply.
	Damaged piston, cup or pump valve	Replace any damaged pump parts and clean out any foreign particles.
	Clogged nozzles	Clean or replace nozzles.
WATER LEAKAGE AT INTAKE MANIFOLD OR CRANKCASE	Worn manifold seals, pistons or O-rings. Or, condensation inside crankcase	Replace seals, sleeves or O-rings. Change oil at regular intervals.
	Inadequate water supply to pump creating a vacuum lock	Ensure adequate tap water supply. Clear inlet filter.
OIL LEAKS	Worn pistons and/or leaking crank seals, crankcase cover seal or drain plugs	Replace seals, sleeves or O-Rings.
EXCESSIVE WEAR	Worn or loose bearings	Replace bearings. Check bearing seals, spacers and retainers. Replace any worn parts.
SHORT PISTON CUP LIFE	Scored cylinders from pumping acids	Replace cylinders. DO NOT PUMP ACID SOLUTIONS. For acid application, ask your dealer for a Pump Saver Injector.
	Abrasive particles in fluid being pumped	Replace water and detergent strainers if damaged or missing. Install additional filter if fine abrasives are still evident.
	Operator(s) running pump without water supply	do not allow washer to be run without proper water supply.
	Hot water in pump	Do not run in bypass for more than 5 minutes. Do not let water supply exceed 140oF (60oC).
IRREGULAR SPRAY PATTERN	Worn or partially clogged nozzle	Clean or replace nozzles.

TROUBLESHOOTING
Detergent System Malfunction

PROBLEM	POSSIBLE CAUSE	REPAIR
WASHER FAILS TO DRAW DETERGENT	Detergent metering valve closed or valve clogged or defective	Open detergent metering valve, following procedure in operating instructions.
	Back pressure in hose (when using additional lengths of pressure hose)	Contact dealer for proper injector size when adding lengths of hose.
	Back pressure in pressure hose (when using dual lance wand)	Use proper size flood nozzle in dual lance wand (refer to parts breakdown).
	Suction tube not below liquid surface	Completely submerge suction tube and strainer in detergent solution.
	Clogged or damaged suction strainer	Clean or replace strainer.
DETERGENT SOLUTION TOO WEAK	Air leak in detergent suction tube or inlet plumbing	Find air leak and clean or replace parts as necessary.
	Clogged detergent strainer	Clean or replace strainer.
DETERGENT SOLUTION TOO CONCENTRATED	Original detergent too concentrated	Dilute product as necessary to achieve proper concentration.
DETERGENT IN RINSE CYCLE	Dual lance wand or adjustable nozzle holder in open position or detergent metering valve open	Close dual lance wand adjustable lance holder to achieve high pressure. Close detergent metering valve.
DILUTION OF DETERGENT CONCENTRATE DURING CYCLE	Worn or defective internal check valve	Repair or replace check valve or injector parts as necessary.
	Defective check valve in detergent tank	Replace parts as necessary.

TROUBLESHOOTING

Unloader Valve Malfunction

PROBLEM	POSSIBLE CAUSE	REPAIR
UNLOADER CYCLES	Fitting leaking downstream	Tighten/replace fitting.
	Piston or valve spring broken or worn	Replace parts as necessary.
	Clogged nozzle	Clean or replace.
FLUID LEAKING FROM BODY	O-ring worn or cut	Replace part as necessary.
UNLOADER WILL NOT COME TO PRESSURE	Foreign particle in valve	Replace or clean.
	Nozzle worn or wrong size	Replace part as necessary.
	Piston or valve worn	Replace part as necessary.
EXTREME PRESSURE SPIKES	Adjusting nut turned completely into unloader	Back off adjusting nut.
	Clogged nozzle	Clean or replace.

General Wire Spring Co. LIMITED ONE YEAR WARRANTY

General Wire products are warranted by General Wire Spring Co. to be free of defects in material and workmanship under normal use for the periods specified below.

General Wire machines carry a one year limited warranty against defect or breakage except as noted below. Should any part break or fail to work properly in the year following purchase, it will be repaired or replaced at our discretion at no charge. Some parts, such as hoses and nozzles, are subject to severe wear and are replaced within a year only if a flaw in the material causes breakage. No adjustment can be made on kinked hoses, since a kink is evidence of abuse. Also, no adjustment can be made where there is considerable wear at the point of the break.

Warranty on service/wear items, replacement parts and electrical components is limited to 90 days.

All parts replaced under warranty must be original General Wire Spring Co. replacement parts. Under no circumstances will General Wire reimburse a service center for parts that are not General Wire parts.

Damage due to negligence, rust, exposure to corrosive chemicals, abnormal usage, accidents or alteration from original design is not covered by this warranty.

Warranty Does Not Cover:

1. Certain items not manufactured by General Wire but used as components such as engines and motors are guaranteed by their respective manufacturer service centers.
2. Items subject to normal wear such as seals, valves, hoses, spray guns, wands, couplings, nozzles, belts, swivels, filters or any part subject to direct physical contact by the public.
3. Replacement of any fluids such as oil or chemicals, nor does it cover cleaning of any parts.
4. General Wire products are only warranted to the original purchaser, there is no continuation of warranty on used products.
5. Products damaged in transit. (A claim should be filed with the carrier in the event a product is damaged in shipment.)
6. Damage caused by the use of caustic or corrosive liquids.
7. Operating the pump under conditions that cause or contribute to cavitation.
8. Damage caused by contaminated fuel or oil.
9. Heat damage within the pumping system, whether introduced with the water supply or generated within the system.
10. Damage caused by accident, fire, flood, wind storm, freeze up or other acts of nature.
11. Damage caused by improper installation or power supply.
12. Cost of transportation to authorized service center.
13. Freight costs are the responsibility of purchaser/dealer.
14. Cost incurred for telephone communications.
15. Travel costs or mileage and/or time.
16. Failure to follow recommended maintenance or operating procedures outlined in the operators manual.
17. Loss of running time, income or any other loss due to down time.
18. Use of unauthorized/substandard accessories or attachments.

In order to obtain warranty service the original purchaser is responsible for:

1. Providing proof of purchase (original invoice or bill of sale).
2. Informing your wholesaler of the defect(s) or problem(s) and making the product available for repair. They will direct you to the nearest authorized Service Center. (Charges for pick-up or delivery, service calls and mileage are not covered under warranty.)

This warranty is made in place of all other warranties, express, statutory or implied, including those of merchantability and of fitness for purpose.

This warranty gives you specific legal rights and you may also have other rights that vary from state to state. Some states do not allow the exclusion of limitation of incidental or consequential damages, so these limitations may not apply to you.

General / **General Wire Spring Co.**
PIPE CLEANERS 1101 Thompson Avenue • McKees Rocks, PA 15136 USA
800-245-6200 or 412-771-6300 • Fax: 412-771-2771
Web Site: www.drainbrain.com

8.914-324.0 / 97-6117 • J-2900 AND J-2000 • REV. 4/08a