



Operator's Manual

Model S60-12020



▲IMPORTANT This manual contains information for the safety of persons and property. Read it carefully before assembly and operation of the equipment!

Spyker Spreaders
Contact Us at 800.972.6130

Hopper Explosion

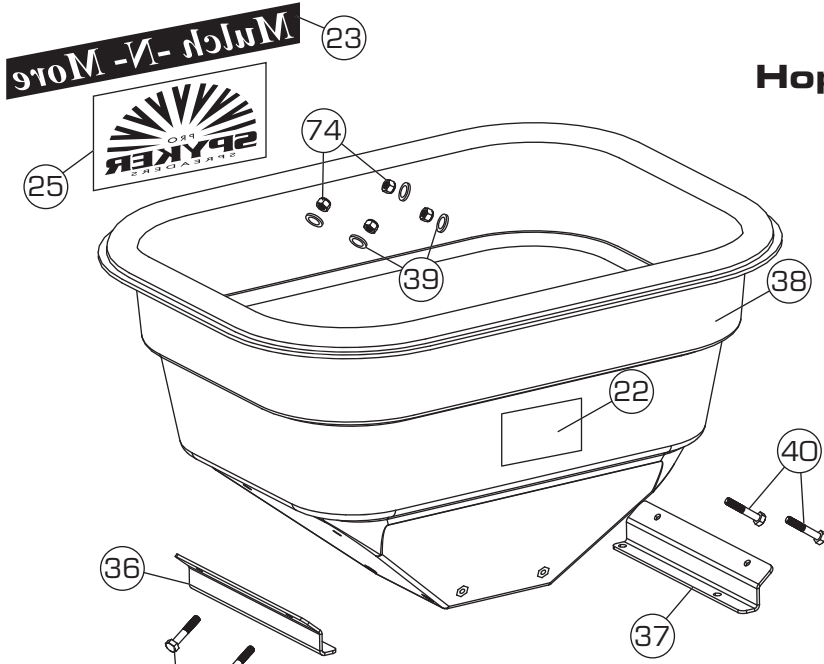

Rate Gate Explosion

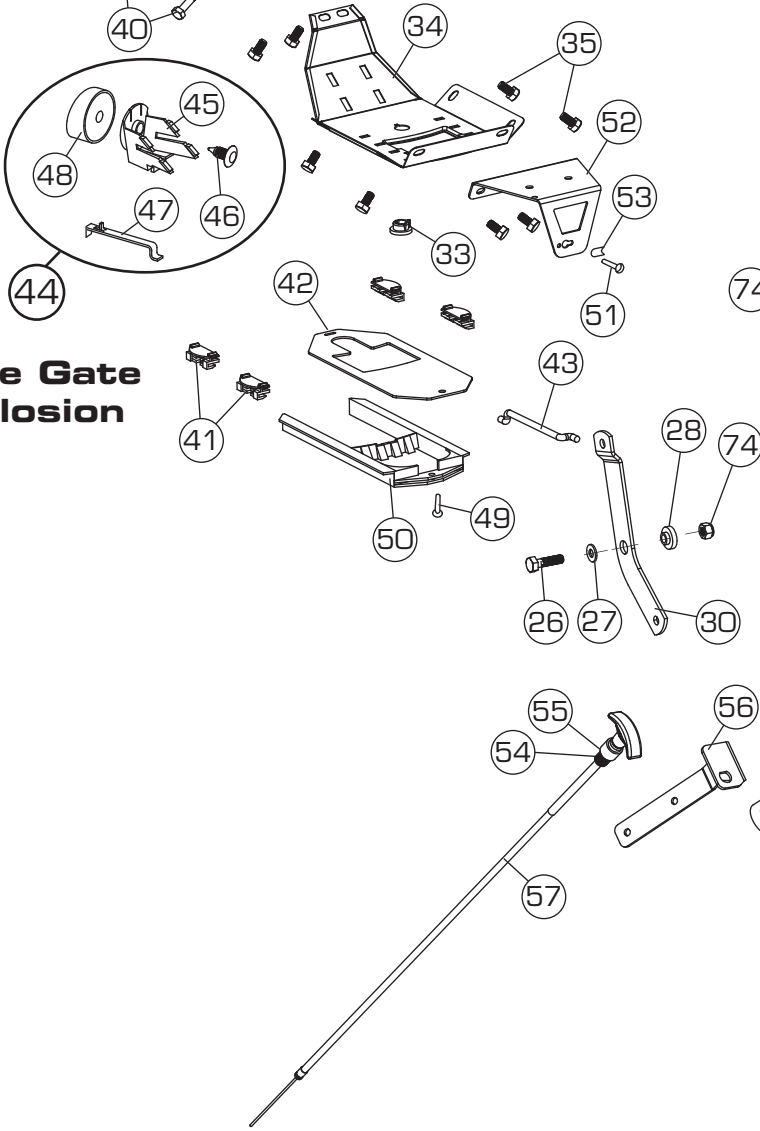

Handle Explosion

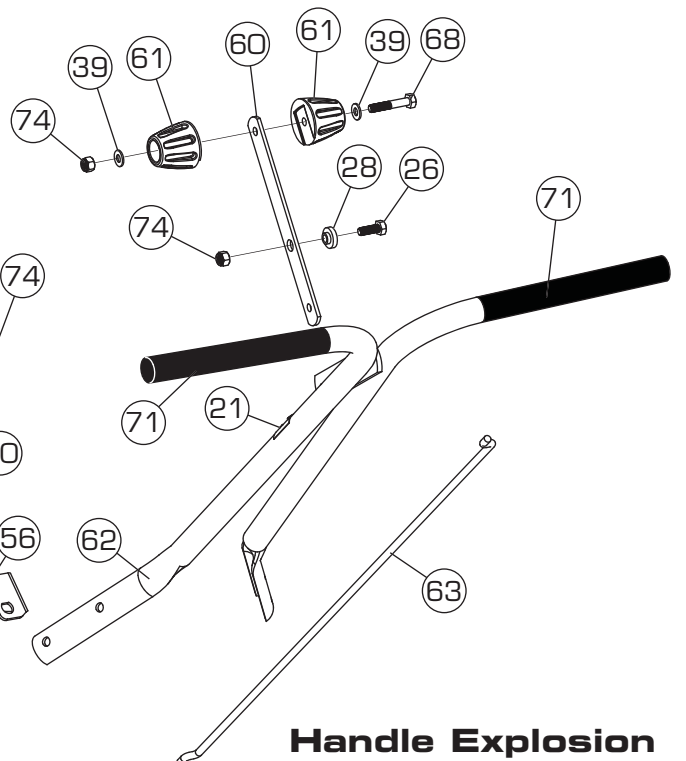

Spinner/Axle Explosion

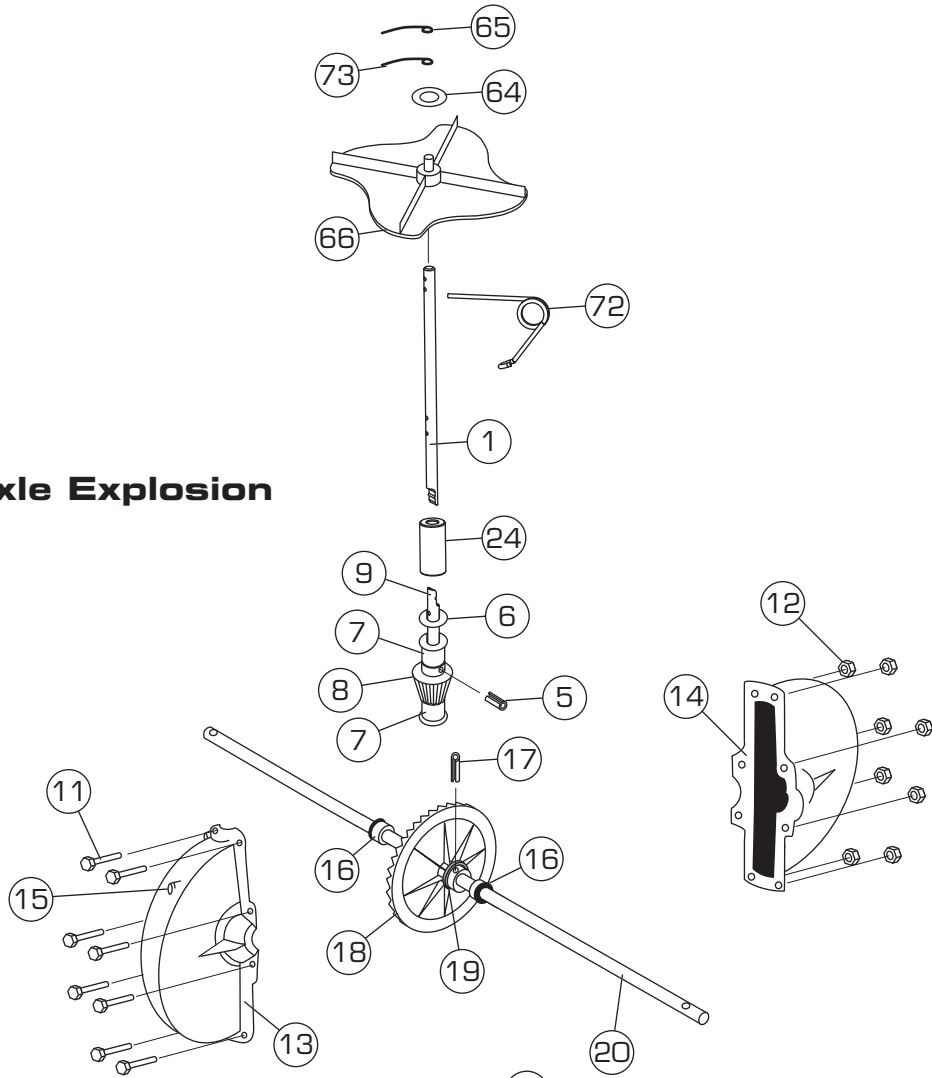

Frame Explosion

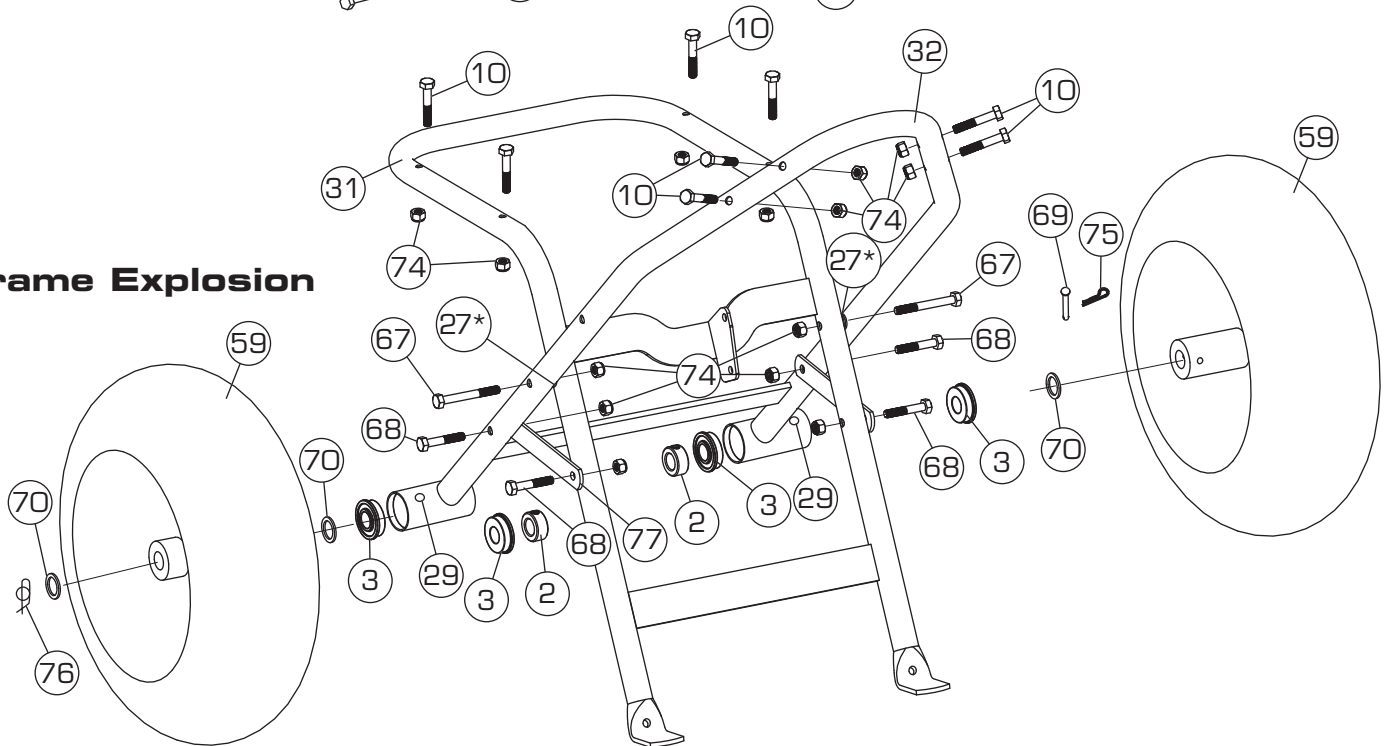

*As needed for shimming

No.	Part Number	Qty	Description	No.	Part Number	Qty	Description
1	1008268	1	Shaft, Upper Spinner	39	05-94-0064	6	Washer, Nylon
2	05-90-0012-R	2	Stainless Steel Collar	40	05-90-0121	4	Bolt, HexHd 1/4x3/4 SS
3	05-98-0071	4	Ball Bearing	41	05-94-0042	4	Guide, Rate Gate/ Accuway
4	1008290	1	Manual S60-12020	42	1008244	1	Rate Gate
5	SS-90-0001	2	Roll Pin 1/8 X 3/4	43	1008270	1	Linkage, Round
6	SS-92-0002	1	Felt Washer	44	05-296-0130	1	Rate Gate & Dial Assy
7	05-90-0094	2	3/8 Spinner Shaft Bushing	45	05-94-0069	1	Dial Mount
8	05-94-0034	1	Pinion Gear - Metal	46	05-94-0078	1	Pine Tree Clip
9	05-288-0035	1	Lower Spinner Shaft, 288	47	05-296-0110	1	Rate Gate Link, Polished
10	05-90-0080	8	Bolt, HexHd 1/4x1-3/4 SS	48	05-296-0131	1	Dial- Milled
11	05-90-0097	8	Bolt, FlgHd 10-24x5/8" SS	49	05-90-0044	1	Wire Fastener Pan Head
12	05-91-0008	8	Nut, NylonLock, #10-24 SS	50	05-296-0175	1	Accuway Diffuser
13	05-94-0037	1	Gear Box Cover Front	51	05-90-0055	1	Bolt, 10-32 x 1/2", SS
14	05-94-0038	1	Gear Box Cover Rear	52	05-288-1025	1	Cable Mount Bracket
15	05-98-0111	1	Grease Zerk 1/4-28	53	05-288-1022	1	Cable Retainer
16	05-90-0093	2	Gearbox Bushing 5/8"	54	05-91-0023	1	Hex Nut, M14 x1.5
17	05-90-0096	1	Dowel Pin, 3/16 x 1, SS	55	05-92-0013	1	Washer/internal Tooth
18	05-94-0033	1	Bevel Gear-metal	56	1008245	1	Bracket, Cable
19	05-288-1027	1	Nylon Spacer, Pin Retain	57	1008277	1	Cable Diffuser
20	1008275	1	Axle, Wheel	58	1008720	1	Screen 13-1/8 x 18- 7/8
21	05-99-0063	1	On-off Decal	59	05-95-0016-JD	2	Wheel, 12" Drive/Idle
22	05-93-0075	1	Spyker Accuway Label	60	1007773	1	Lever, Control
23	05-93-0109	1	Decal Mulch-n-more	61	B-8558	2	Knob, Handle
24	1008267	1	Coupling	62	1008069-01	1	Dual Handle Weld Polished
25	1008067	1	Decal Spyker Square Blue	63	1008269	1	Rod, Control
26	05-90-0047	2	Screw 1/4-20 X 1"HexHd,SS	64	SS-92-0002	1	Felt Washer
27	05-92-0008	7	Washer, 1/4" SS	65	SS-96-0003	1	Agitator Wire
28	05-94-0051	2	Nylon Flange Bushing	66	05-220-0140	1	Spinner - Drilled (black)
29	05-98-0051	2	Grease Zerk 1/4-28	67	05-90-0017	2	Bolt, 1/4-20 X 2-3/4"
30	1008246	1	Linkage, Pivot	68	05-90-0054	5	Bolt, HexHd 1/4x1-1/2 SS
31	1008273-01	1	Hopper Suppt Weld Polish	69	05-90-0065	1	Clevis Pin, 3/16x1-3/4
32	1008274-01	1	Axle Tube Weldm Polish	70	05-92-0004	5	Washer, Flat SS
33	SS-94-0007	1	Hopper Bottom Bearing	71	05-94-0022	2	Handle Grips, .930id X
34	05-296-2215	1	Mulch Bottom, Polished	72	05-97-0031	1	Spinner Clip SS
35	99-10-0205	8	Bolt, HexHd 1/4x1/2 SS	73	SS-297-0003	1	Agitator Wire
36	1008250LH	1	Brace, Hopper LH	74	SS-91-0004	21	Nut, NylonLock 1/4-20, SS
37	1008250RH	1	Brace, Hopper RH	75	05-90-0102	1	Hair Pin, SS Pivot Mount
38	1008271	1	Hopper, 120 Drilled	76	05-90-0040	1	Rue Ring Locking Pin
				77	1007794	2	Brace, Cross

1. Remove clips from axles on outside of axle frame assembly.
Install wheel washer on each end of axle.
2. Install Wheel on each side of axle (Valve Stem Out).
On the drive wheel side, install $3/16 \times 1-3/4$ " Clevis Pin and Cotter Pin, Figure 1. On opposite side install wheel washer and Rue Ring Locking Pin on outside of wheel.

NOTE: Extra wheel washers are provided and are to be used for shimming as needed. Wheels need to set snug against frame.

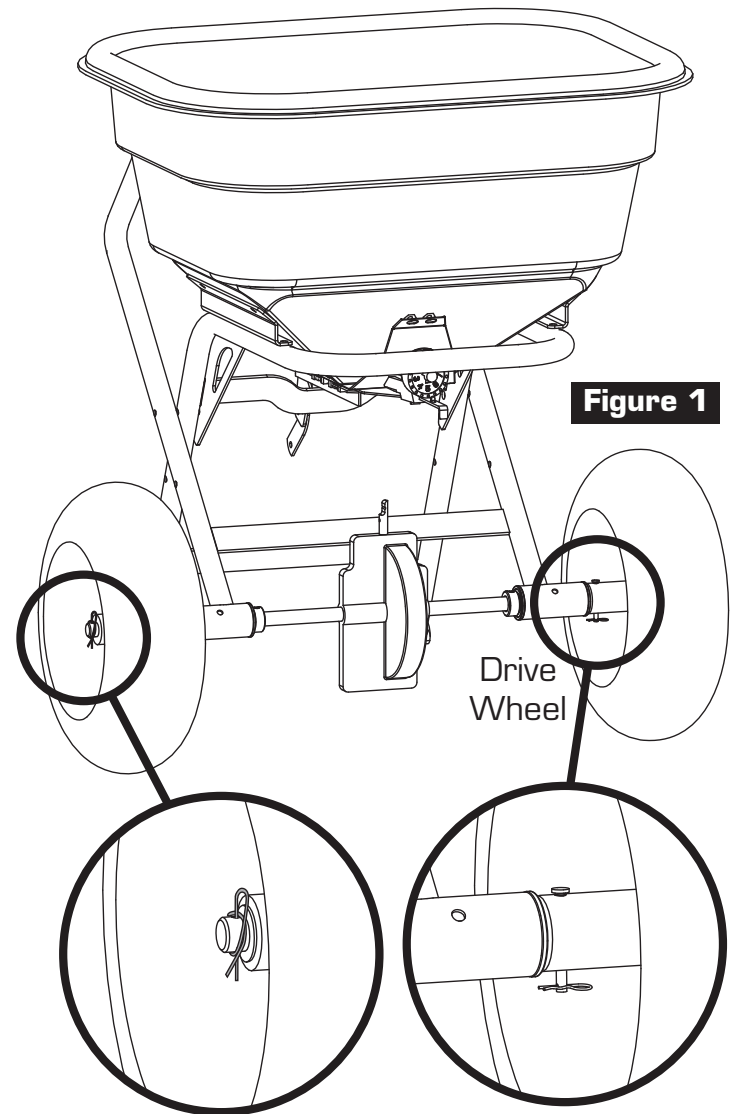

Figure 1

3. Install Cross Braces to frame as shown, Figure 2. Install using (4) $1/4 \times 1-1/2$ " Bolts and Locknuts.

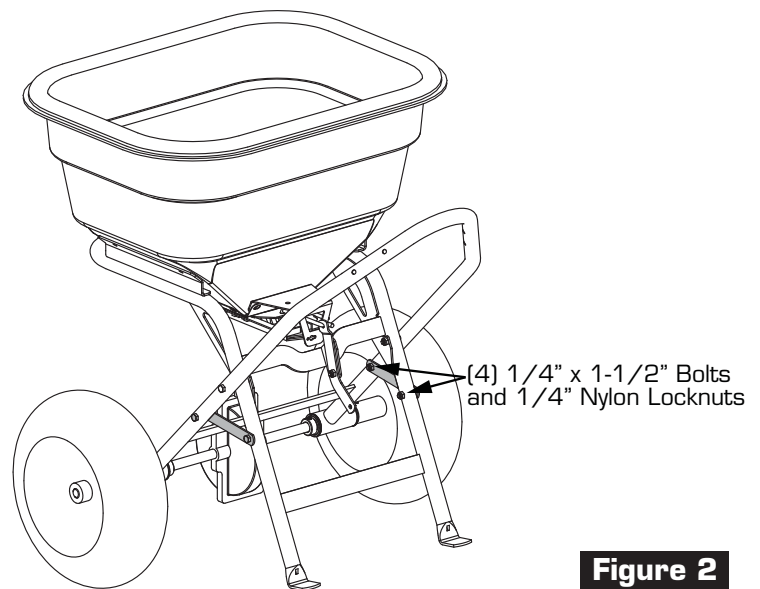

Figure 2

4. Install linkage to lever, Figure 3.

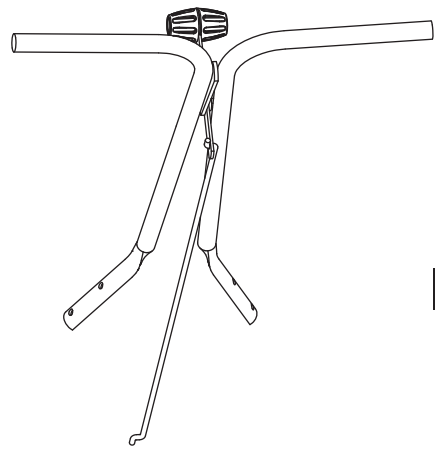

Figure 3

5. Turn handle/linkage assembly sideways and insert end of linkage into rate gate linkage, Figure 4.

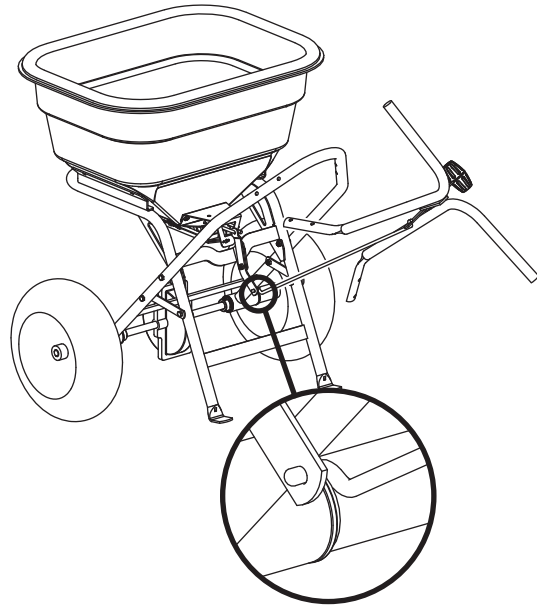

Figure 4

6. Install handle to frame as shown using 1/4" x 1-3/4" Bolts and Locknuts. NOTE: You'll need to orient and install the cable bracket as shown on the left side of the spreader, Figure 5.

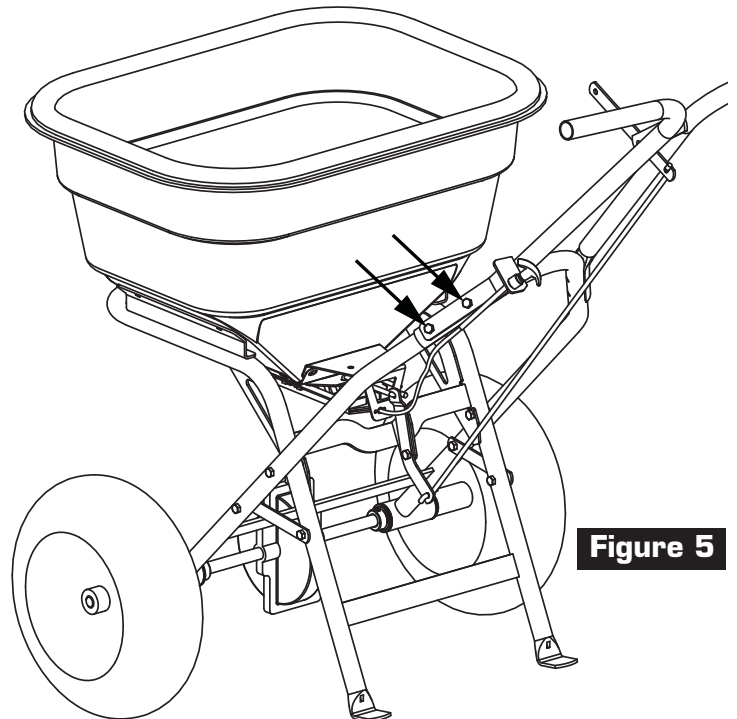

Figure 5

7. Install two agitator wires on the upper spinner shaft. The larger agitator goes on the top/end of the shaft. Note orientation of agitator on page 9.
8. Install felt washer on shaft below the agitator wires. Slide shaft down through hopper. Install fan and coupler, Figure 6. Assemble so upper and lower spinner shafts interlock grooves. Slide coupler down over shafts.

Ensure the factory installed felt washer is on the lower spinner shaft, Figure 6.

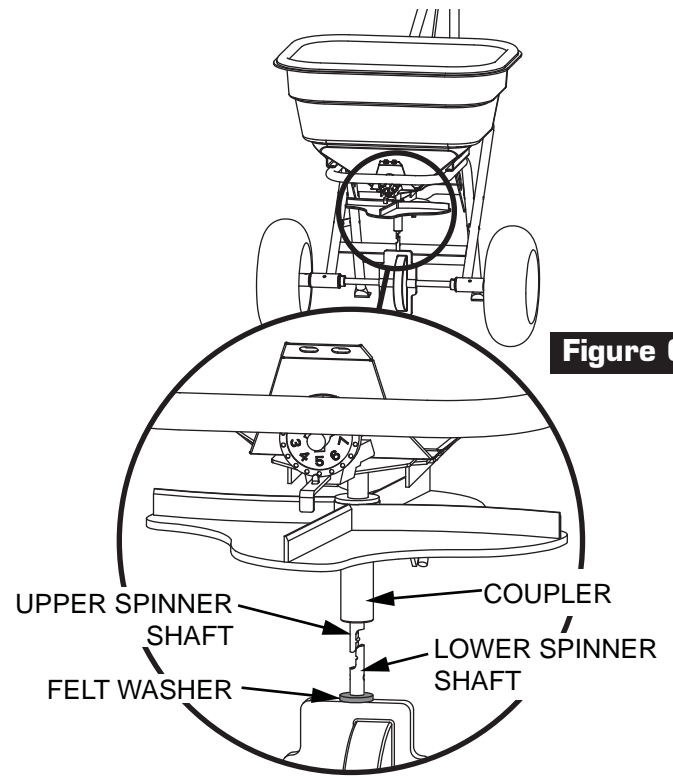

Figure 6

9. Slide coupler all the way down onto the felt washer on the lower spinner shaft, Figure 7. Insert spinner spring through the fan and **upper** hole on the spinner shaft. Wrap spring around shaft and clip into place as shown, Figure 7.

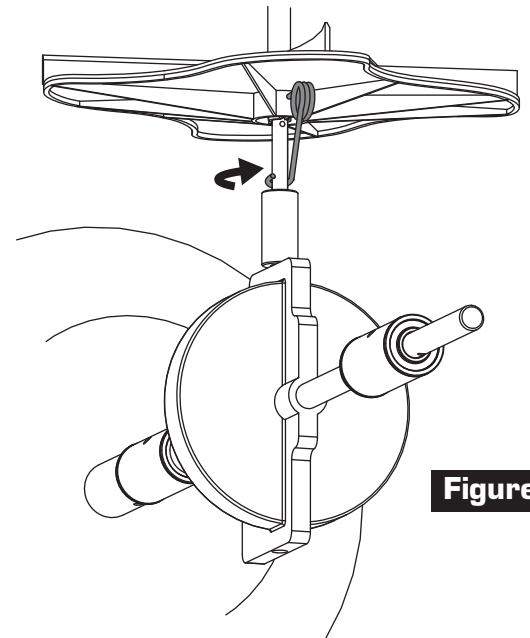

Figure 7

10. Install handle grips, Figure 8.

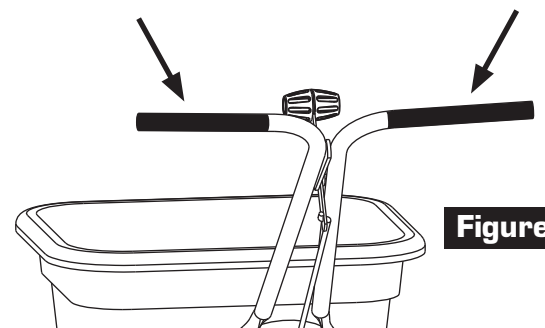

Figure 8

READ BEFORE USING

OPERATE SAFELY

Keep bystanders away when you operate this machine.

Use this machine for intended purpose only.

Do not let children or an untrained person operate machine.

Keep all parts in good condition and properly installed. Fix damaged parts immediately. Replace worn or broken parts.

Do not modify the machine or safety devices. Unauthorized modifications to the machine may impair its function and safety, and void the warranty.

Do not let anyone sit or ride on equipment during operation. Keep riders off attachment.

Wear substantial footwear and long trousers. Do not operate the equipment when barefoot or wearing open sandals.

Do not wear loose fitting clothing that can get caught in moving parts.

Always wear eye protection when operating the equipment.

Stay alert for holes in the terrain and other hidden hazards.

Watch out for traffic when crossing or near roadways.

Before you operate any feature of this machine, observe your surroundings and look for bystanders.

Always wash hands after contact with fertilizers and pesticides.

Keep all nuts, bolts and screws tight to be sure the equipment is in safe working condition.

TROUBLESHOOTING

Spreader does not sit flat	The "feet" or the flattened portion of the spreader hopper support tubes are not bent equally.	Using a hammer or pliers, bend the feet to be equal with each other.
Deflector shut off is binding and will not open/close properly	Shut off plate is jammed with debris.	Thoroughly wash out hopper and shut off plates with water. Ensure debris is not stuck between shut off plate and rate gate plate.

READ BEFORE USING

Become Familiar With The Operation Of The Spreader Before You Put Material In The Hopper

- Practice walking with the spreader, opening and closing the rate gate at the appropriate times.
- Travel at a constant speed and operate the spreader lever position. Remember: Open the rate gate after the spreader is in motion at operating speed (about 3 mph, or at a brisk walking pace).
- Close the rate gate while spreader is still at operational speed.

Dial Setting Information

The RATE DIAL has 9 numbers with 10 stops between each number. This allows for accurate control of the spreading rate. The dial is set with only a turn, it will automatically lock into the set position. **LINE UP THE DIAL NUMBER WITH THE DIAL INDICATOR.**

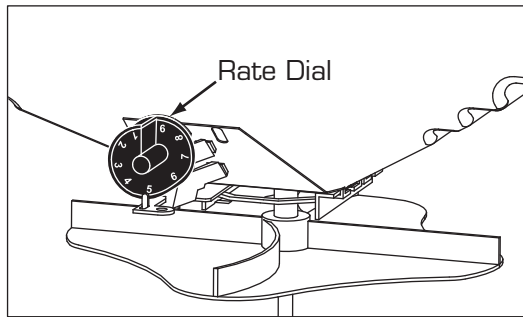

- The spread width ranges from 4 - 12 ft. wide depending on the volume/density, particle size of the material, and rate of travel.
- The spread thins or feathers at the outer edges, eliminating sharp, "Edge Of Spread" lines which cause stripes and streaks. Extra coverage can be given under trees and other heavy feeding areas without showing "Edge Of Spread" lines.
- Gaps and double overlaps are less likely. Small errors in travel are forgiven and do not show.

WARNING: When spreading products containing herbicides, exercise extreme caution with respect to careless spreading and to wind-drift.

Contact Of Some Products On Some Plants Can Be Fatal

If a dial setting is not found, use the size and weight comparison table found in this manual. Determine a

dial setting on the low side. If the setting proves to be too low, cover the area more than one time. A higher setting can be used when a proven dial setting is established.

Remember: Published dial settings are approximate only. The operation of the spreader, the condition of the material (damp or dry or over-pulverized) and weather conditions, are all contributing factors. For these reasons, it is often a good idea to spread the area 2 times - or one-half rate - in cross directions (SEE INFORMATION ON ONE-HALF RATE DIAL SETTINGS). One-half rate dial settings are highly recommended under damp and humid conditions.

Rotary Agitator

Use the rotary agitator only if needed. Free-flowing, lump-free materials will not require the agitator. The rotary agitator is easily installed or removed. Note the clockwise rotation and sweep. Place felt washer around spinner shaft before inserting agitator.

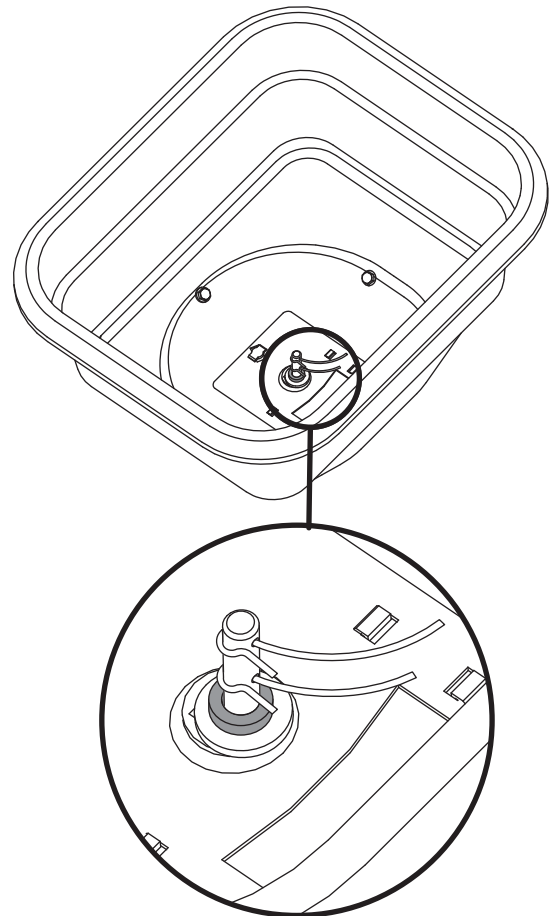

READ BEFORE USING

Now You Are Ready To Put Material In The Hopper

WARNING: Avoid Injury! Chemicals can be dangerous. Avoid injury to operators or bystanders.

- Make sure the rate gate is in the closed position.
- Read chemical container label for handling instructions. A Material Safety Data Sheet (MSDS) should be supplied by the chemical dealer and provides proper safety information.
- Wear proper clothing and safety equipment while handling or applying chemicals.
- Prohibit all smoking, drinking, and eating around chemicals.
- When spreading products containing herbicides, exercise extreme caution with respect to careless spreading and to wind-drift. Contact Of Some Products On Some Plants Can Be Fatal.
- Fill the spreader on a flat, level surface only. Fill on sidewalk, driveway, cardboard, etc. to avoid material loss.
- When filling hopper with material, always use screen to help break up clumps.

Now You Are Ready To Spread

- Keep spinner blade clean. Excess material build-up can cause an uneven spread pattern.
- Keep the impeller level when spreading.
- DO NOT overload. Maximum capacity is 120 lbs.
- DO NOT use on windy days.
- Spread header strips at the ends of the area OPPOSITE of the direction of spreading. This will provide a "turn-around" area, an area to re-align the spreader for the return spread.
- Example shown is for 6 ft. wide spread. Make the first spread pass at one-half the spread width from the edge of the spreading area or in this case, approximately 3 feet (or one big step).
- Additional spreading passes will be at the full spread width or approximately 6 ft. apart.
- TAKE A SIGHTING AT THE FAR END. Keep your eye on the sighting as you spread. You will not need

to wonder where you are or where you have been. Continue until spreading is completed.

- Left over fertilizer can be spread under trees and other high feeding areas without showing "edge of spread" lines.

Tip: When not spreading, and if pushing the spreader some distance, tip the spreader so only the idle wheel is on the ground.

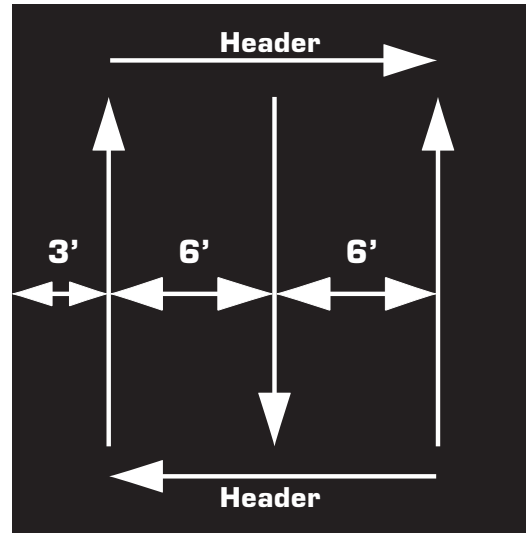

Cleaning The Spreader Is Part Of The Spreading Job

Clean and oil spreader immediately after each use.

Method #1 - Wipe spreader thoroughly with an oily cloth. Oil all bearings and bearing areas.





Method #2 - Wash, rinse, and dry the spreader. Note: Drying takes time. Moisture trapped in bearing areas is slow to go. Immediately after drying - oil all bearings and moving parts. Make certain all operations are thorough.

NOTE: Good "Dry Cleaning" is preferable to poor "Wet Cleaning".

- It is virtually impossible to have rust and corrosion on a clean, dry, oiled surface.
- Again - just before using - oil all bearings and moving parts.
- In storage, ideally the spreader should be hung by the handle. In any case, do not pile weight on the spreader, as excess weight over a period of time can distort the tires.

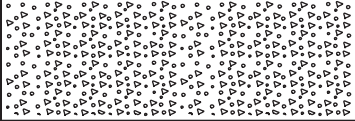
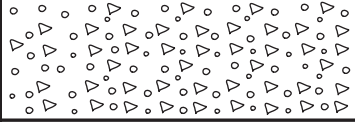
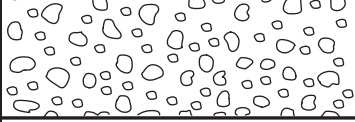
Oil Bearings And All Moving Parts

Make sure the spreader is running freely!

NOTE: Dial Settings Are Approximate Only !			Dial Settings		Dial Settings		
Product	Particle Size	Lbs. per 1000 sq. ft.	Full Rate	↑	↓	Half Rate	↕
			Once Over			Twice Over	
Fine Pellets		1	3.6			3.1	
		2	4.0			3.5	
		3	4.2			3.7	
Mixed Fine Pellets		2	3.7			3.2	
		4	4.7			4.1	
		6	5.2			4.5	
Small Pellets		2	3			2.2	
		4	4.2			3.7	
		6	4.5			4	
Nitrogen Pellets Medium Size		1	3.5			3	
		2	4.2			3.7	
		3	4.7			4	
Medium Pellets And Granuals		2	3.5			3	
		4	4.2			3.8	
		6	5.2			4.5	
Large Heavy Pellets		2	3.8			3.3	
		4	4.9			4.1	
		6	5.9			4.9	

GRASS SEED SPREADING CHART					
Product	Bag Weight	Sq. Ft. Coverage	Dial Setting Full Rate	Dial Setting Half Rate	Spread Width
Blue Grass or Red Top	.5 lbs.	1,000	1.25		4
	1 lbs.	1,000	2.0		4
	2 lbs.	1,000	2.5		4
Park, Merion, Delta, or Kentucky Bluegrass	.5 lbs.	1,000	2.5		4
	1 lbs.	1,000	3.0		4
	2 lbs.	1,000	3.5		4
Hulled Bermuda	2 lbs.	1,000	2.75	2.25	6
	3 lbs.	1,000	3.0	2.5	6
	4 lbs.	1,000	3.25	2.75	6
Mixtures Including Coarse Seeds	2 lbs.	1,000	6.0		6
	4 lbs.	1,000	7.0		6
	6 lbs.	1,000	7.0		6
Rye Grasses or Tall Fescue	2 lbs.	1,000	6.0		6
	4 lbs.	1,000	7.0		6
	6 lbs.	1,000	7.75		6
Dichondra	4 oz.	1,000	1.9		8
	8 oz.	1,000	2.1		8
	12 oz.	1,000	2.5		8
Pensacola Bahia	4 lbs.	1,000	4.5	3.75	7
	5 lbs.	1,000	4.75	4.0	7
	6 lbs.	1,000	5.0	4.25	7



1 YEAR LIMITED WARRANTY

This is warranted to the original purchaser only. Spyker will replace parts with defects in materials and workmanship, for a period of one year from the date of purchase.

For Spyker Spreaders—a Brinly-Hardy Company, products employing metal gear systems, pinion and bevel, these metal gears, only, not inclusive of any other parts or materials, are warranted for the life of the spreader, not to be used for replacement or repair past original purchase.

Spyker Spreaders will not be liable for any loss, damage or expense including, but not limited to, consequential or incidental damages, arising from the operation, condition or use of the item. The sole and exclusive remedy against Spyker Spreaders being the replacement of the defective parts. This warranty gives you specific legal rights, and you may also have other rights which vary from state to state.

This express warranty, which is applicable only to the original purchase, is in lieu of and excludes all other warranties, whether expressed or implied by operation of law or otherwise, including any warranty of merchantability or fitness for particular purpose.

**SPYKER SPREADERS
Jeffersonville, IN 47130 USA
Phone: 800.972.6130**