



**X-CITY**

**4x320W LED**

**Lighting Tower**

USE MANUAL



Model: X-CITY – A0102  
User's manual: MI120A00102  
Rev.00  
Date: 05/08/2019

*Dear customer,*

*We wish to thank you very much for having purchased our product. With proper handling and maintenance, this product will provide dependable, long-term service. Our customer service is always available, might you need it.*

*This manual is intended for users of the equipment. This manual is compiled from information available and current at time of approval for printing.*

*Please consider that this manual may refer to controls and optional equipment that are not present on your particular machine.*

*It is important that you know your machine and its equipment and how to operate it properly, so **please read the operating instructions carefully and understand them before operating the machine.***

*Machine specifications can be modified at any time without any obligation to update this publications. It is recommended to read this manual thoroughly because incorrect operation may result in the warranty being void.*

*It is also recommended to use only original factory spare parts*

**Reproduction of this manual is not permitted, unless written approval is obtained from factory.**



Trime S.r.l.

Strada per Robecco 20081 Cassinetta di Lugagnano (MI) Italy.  
Tel. +39029421724 - e-mail: [info@trime.it](mailto:info@trime.it) - Internet: [www.trime.it](http://www.trime.it)

---

**TABLE OF CONTENTS**

<b>SAFETY RULES .....</b>	<b>4</b>
<b>SAFETY PRECAUTIONS TO BE OBSERVED .....</b>	<b>4</b>
<b>FIRE PRECAUTIONS .....</b>	<b>4</b>
<b>FLAMMABLE FLUID PRECAUTIONS .....</b>	<b>4</b>
<b>ELECTRICAL HAZARD .....</b>	<b>5</b>
<b>LUBRICATION AND SERVICING .....</b>	<b>5</b>
<b>TOWING SAFETY .....</b>	<b>5</b>
<b>SAFETY STICKERS GUIDE .....</b>	<b>6</b>
<b>TECHNICAL SPECIFICATIONS .....</b>	<b>7</b>
<b>LIGHT TOWER IDENTIFICATION .....</b>	<b>7</b>
<b>TECHNICAL DATA .....</b>	<b>8</b>
<b>MACHINE FEATURES .....</b>	<b>10</b>
<b>HANDLING AND TRANSPORT .....</b>	<b>12</b>
<b>TOWING &amp; MOVING WITH TOWING VEHICLE .....</b>	<b>12</b>
<b>HANDLING AND TRANSPORT WITH CRANE .....</b>	<b>12</b>
<b>HANDLING AND TRANSPORT WITH FORKLIFT .....</b>	<b>13</b>
<b>LIGHTING TOWER USE .....</b>	<b>14</b>
<b>STABILIZING THE UNIT .....</b>	<b>14</b>
<b>DIRECTING THE FLOODLIGHTS .....</b>	<b>14</b>
<b>PRELIMINARY CHECK &amp; STARTING .....</b>	<b>14</b>
<b>DSE L401 CONTROL UNIT: DESCRIPTION OF CONTROLS .....</b>	<b>15</b>
<b>DSE L401 CONTROL UNIT: MODULE DISPLAY .....</b>	<b>16</b>
<b>DSE L401 CONTROL UNIT: INSTRUMENTATION ICONS .....</b>	<b>16</b>
<b>DSE L401 CONTROL UNIT: ALARM ICONS (PROTECTIONS) .....</b>	<b>17</b>
<b>DSE L401 CONTROL UNIT: WARNING ALARM ICONS .....</b>	<b>18</b>
<b>DSE L401 CONTROL UNIT: SHUTDOWN ALARM ICONS .....</b>	<b>19</b>
<b>DSE L401 CONTROL UNIT: NAVIGATION MENU .....</b>	<b>20</b>
<b>DSE L401 CONTROL UNIT: SCHEDULER EDITING FROM INSTRUMENTATION SCREENS .....</b>	<b>22</b>
<b>DSE L401 CONTROL UNIT: VIEWING ACTIVE ENGINE DTC .....</b>	<b>23</b>
<b>DSE L401 CONTROL UNIT: TIMER .....</b>	<b>24</b>
<b>ROUTINE MAINTENANCE .....</b>	<b>26</b>
<b>DISPOSAL AND DECOMMISSIONING .....</b>	<b>26</b>
<b>SPARE PARTS .....</b>	<b>28</b>
<b>FLOODLIGHTS .....</b>	<b>28</b>
<b>STEEL ROPES AND PULLEYS .....</b>	<b>29</b>
<b>MAST .....</b>	<b>30</b>
<b>BASE .....</b>	<b>32</b>
<b>CANOPY .....</b>	<b>34</b>
<b>TOW BAR, AXLE AND WHEELS .....</b>	<b>36</b>
<b>ENGINE .....</b>	<b>37</b>
<b>CONTROL PANEL .....</b>	<b>38</b>
<b>ELECTRICAL DIAGRAM .....</b>	<b>40</b>
<b>WARRANTY .....</b>	<b>45</b>

## SAFETY RULES

### SAFETY PRECAUTIONS TO BE OBSERVED

Read this manual and learn the operating characteristics and limitations of the machine before operating it.

The manufacturer declines all liability for injury to persons and damage to components due to not respecting the safety rules.

Report all malfunctions to a maintenance responsible. If there are any repairs to be done, do not operate the equipment. Normal service and maintenance, if performed as required, can prevent unexpected and unnecessary down time. This manual describes standard inspections, operation and servicing with the normal safety precautions required for normal servicing and operating conditions. Operators and maintenance personnel must be safety conscious and alert to recognize potential operating or servicing safety hazards at all times. They should immediately take the necessary precautions to ensure safe operation and servicing of the machine.



- Be aware of operating risks that may be created by weather changes. Follow the correct procedures in the event of heavy rain or electrical storm.

- Lower tower when not in use, or if high winds or electrical storms are expected in the area.
- Use protective clothing and safety equipment: gloves, safety boots, safety hard hat, goggles, ear protection, and dust masks when necessary.
- Know all side clearances and overhead obstructions for safe operation of the machine.
- ALWAYS** make sure area above the tower is open and clear of any kind of obstruction.
- Position and operate the lighting tower on a firm surface.
- The machine must be levelled and outriggers extended before raising tower.
- Keep area around the machine clear of people while raising and lowering the mast.
- ALWAYS** handle fuels and lubricants carefully, clean up spills to avoid fire and slipping risks.
- NEVER** using the unit if it is in need of repair.
- The area near the exhaust pipe become hot in use. Be careful if you need to work there.
- Check that winch cables are in good condition and are centered on each pulley.
- DO NOT** use the unit if insulation on the electrical cord is cut or worn through.
- DO NOT** permit to untrained personnel to operate the machine.
- NEVER** operate a unit if you are tired, not concentrated or under the influence of drugs or alcohol.
- Keep children and animals away from the machine.

### FIRE PRECAUTIONS



- Clean all dirt, oil and other fluids from components to minimize fire risks and aid in spotting loose or leaking components.

- Check the engine for oily rags or other debris that could be potential cause of fire before starting the unit.
- Have a fire extinguisher nearby. Be sure the extinguisher is properly maintained and be familiar with its use.
- In the event of fire, the following extinction means are appropriated: carbonate anhydride (or carbon dioxide), powder, foam, nebulized water. Avoid to use water jets.
- In the event of fire, wear a breathing apparatus if there is heavy smoke.

### FLAMMABLE FLUID PRECAUTIONS



- Take due care when working with fuel. Diesel fuel is a health hazard. Be aware that there is also danger of fire and pollution.

- DO NOT** clean the unit components using flammable fluids.
- Check and ensure that all-fluid systems caps, drain, valves, fittings, lines etc., are secure and leak free.
- ALWAYS** shut off engine while refueling and be very cautious if engine is still hot.
- NEVER** smoke while checking or adding fuel or handling fluid containers.
- NEVER** refuel near an open flame
- DO NOT** fill the tank completely.
- DO NOT** refuel in an enclosed area with poor ventilation.
- DO NOT** run engine without the fuel tank cap.
- DO NOT** use the machine in areas with risk of explosion or fire.

## SAFETY RULES

### ELECTRICAL HAZARD



- DO NOT** smoke or allow open flames or sparks near the batteries.

- Before doing repair works, **ALWAYS** disconnect batteries. Disconnect negative terminal first and reconnect last.
- Before carrying out any welding on the machine, **ALWAYS** make sure to disconnect batteries and alternator leads.
- The tools must **NOT** come into contact with the battery terminals with the risk of creating an electric arc.
- Use jumper cables only. Improper use can result in severe damage and safety risk.
- NEVER** use the machine if insulation on electrical cord is cut or worn through.
- NEVER** operate lights without protective lens cover in place or with a lens cover that is cracked or damaged!

### LUBRICATION AND SERVICING



- Only authorized and trained personnel is allowed to perform the machine maintenance. Please read the operator's manual and maintenance manual before using or servicing the machine.

- HIGH VOLTAGE!** This equipment utilizes high voltage circuits. Always exercise extreme caution when trouble shooting or repairing any electrical circuit.
- Only a qualified electrician should troubleshoot or repair electrical problems occurring on the machine.
- Before servicing the lighting tower, ensure that the engine start switch is turned to OFF.
- Disconnect electrical power and turn off engine before removing protective covers on high voltage electrical closures.
- NEVER** perform even routine service (oil/filter changes, cleaning, etc.) if all electrical components aren't shut down.
- NEVER** allow water to accumulate at the base of the machine. If water is present, **DO NOT** service!
- DO NOT** service electrical components if your clothing or skin is wet.
- If the unit is stored outside, check the engine and generator for any moisture. If wet, dry the unit thoroughly before starting.
- Never wash the unit with a high pressure hose or with any kind of power washer.
- Open main circuit breaker before disconnecting battery cables.
- Ensure to always relieve pressure before servicing any pressurized system.
- Be aware of hot exhaust pipes and engine.
- KEEP AWAY** from moving parts on generator and engine. Be aware of the hazard if you wear loose clothing.
- Check and replace all missing and hard-to-read labels.
- Make sure slings, chains, hooks, ramps, jacks, and other types of lifting devices are attached securely and have enough weight-bearing capacity to lift or hold the equipment safely.

### TOWING SAFETY



- Be careful while towing a trailer!** Both the trailer and vehicle must be in good condition and securely fastened to each other.

- Check that the hitch and coupling on the towing vehicle are adequately dimensioned and rated to the trailer's "gross vehicle weight rating" (GVWR).
- Do not tow a trailer using defective parts coupling!
- Check the tires of the trailer: tread wear, tire pressure, general conditions.
- Connect breakaway safety line securely to towing vehicle.
- If fitted, connect safety chains in a crossing pattern under the connecting beam.
- Check that wheel nuts are ALL tight.
- Check that the road running lights are connected and operating, if applicable.
- Maximum recommended speed for highway towing is 75 km/h. Recommended maximum off-road towing speed is 15 km/h (less on uneven terrain).
- When towing, maintain extra space between vehicles and avoid soft shoulders, curbs and sudden lane changes. If you are not experts in tow, to practice in a far from heavy traffic area.

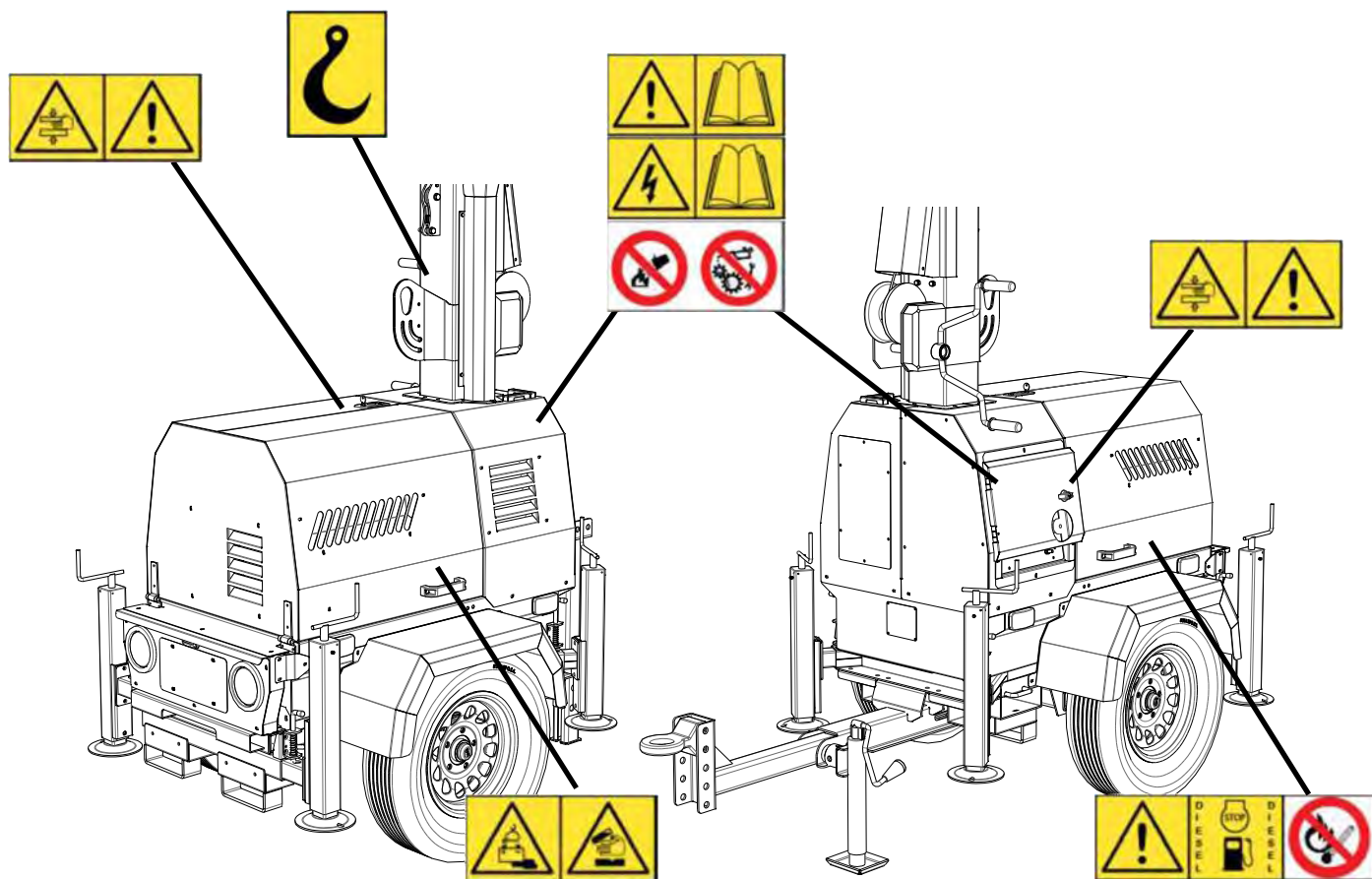

Safety stickers meanings



Attention! Read user's manual before operating the machine.



Attention, high voltage! Read user's manual before operating the machine.



Do not extinguish with water! Attention, don't touch the moving parts.



Attention! Danger of crushing.



Attention, battery on board. Contains corrosive liquids.



Attention! Hot liquid under pressure during machine use and immediately after. Pay attention when opening.



Lifting point. Ensure lifting device has enough capacity to handle machine weight.



Attention! Diesel fuel on board. Stop the engine while refueling. Keep anything that could cause sparks, flame or fire at a safety distance from the machine.



Earthing point. The grounding of the machine always needs to be done paying attention on the section of the cable to be used (never to be less than 10 mm<sup>2</sup>).

TECHNICAL SPECIFICATIONS

LIGHTONG TOWER IDENTIFICATION

		1				
		2				
3		Type	4			
5	6		7			
	Engine		8			
Alternator						
	V	10	Hz	12		
9	KVA	11	COS $\phi$	13		
	RPM	14	I.CL.	15	IP	16
Dimensions L x W x H		17				
Weight		18				
SERIAL N°		19				

1. Manufacturer's logo
2. Manufacturer's address
3. Manufacture year
4. Machine model
5. CE Logo
6. Generator symbol
7. Engine type
8. Alternator type
9. Single phase machine
10. Rated voltage
11. Rated power
12. Frequency
13. Power factor
14. Engine speed
15. Insulation class
16. Degree of protection
17. Machine dimensions
18. Dry weight
19. Machine serial number

Information regarding the machine model, code and year of production is on the unit serial number plate. Always quote the machine model and serial number when contacting your dealer, the factory and for any spare parts requests. All of our products comply with CE requirements. They are conform to directives and fulfill all the relevant safety requirements.

**TECHNICAL SPECIFICATIONS****TECHNICAL DATA**

<b>FLOODLIGHTS</b>	
Type	<b>Led</b>
Power of each lamp	<b>320W</b>
Installed floodlights	<b>4</b>
Illuminated area (5 lux min.)	<b>4500 m<sup>2</sup></b>
IP Level	<b>67</b>

<b>MAST</b>	
Lifting Method	<b>Hydraulic</b>
Maximum Height	<b>8 m</b>
Maximum Wind Speed	<b>110 km/h</b>

<b>GENERATOR</b>	
Model	<b>Linz SP10M</b>
Rated output	<b>4,2Kva 230V</b>
Rated frequency	<b>50Hz</b>

<b>ENGINE</b>	
Model	<b>Yanmar L70AE EPA</b>
Cylinders number	<b>1</b>
Displacement	<b>320 cm<sup>3</sup></b>
Engine speed (rpm)	<b>3000</b>
Fuel consumption (l/h)	<b>0,5 l/h</b>
Average runtime before refueling	<b>82 h</b>
Cooling system	<b>Air</b>

  

<b>GENERAL INFORMATIONS</b>	
Noise level	<b>65dBA 7m</b>
Battery	<b>12 V – 38 Ah</b>
Fuel tank capacity	<b>41 l</b>
Dry weight	<b>600 kg</b>



DIMENSIONS

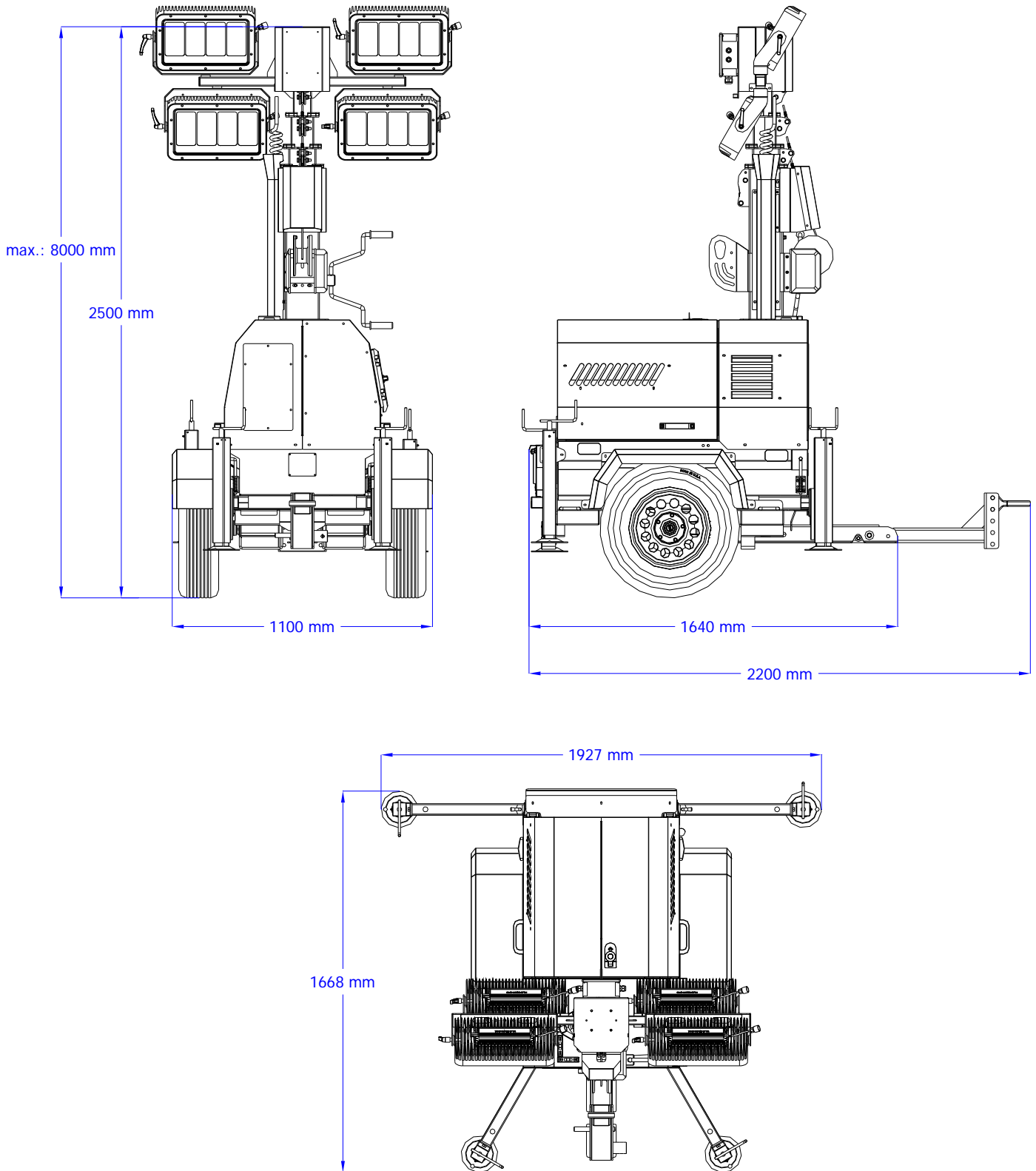

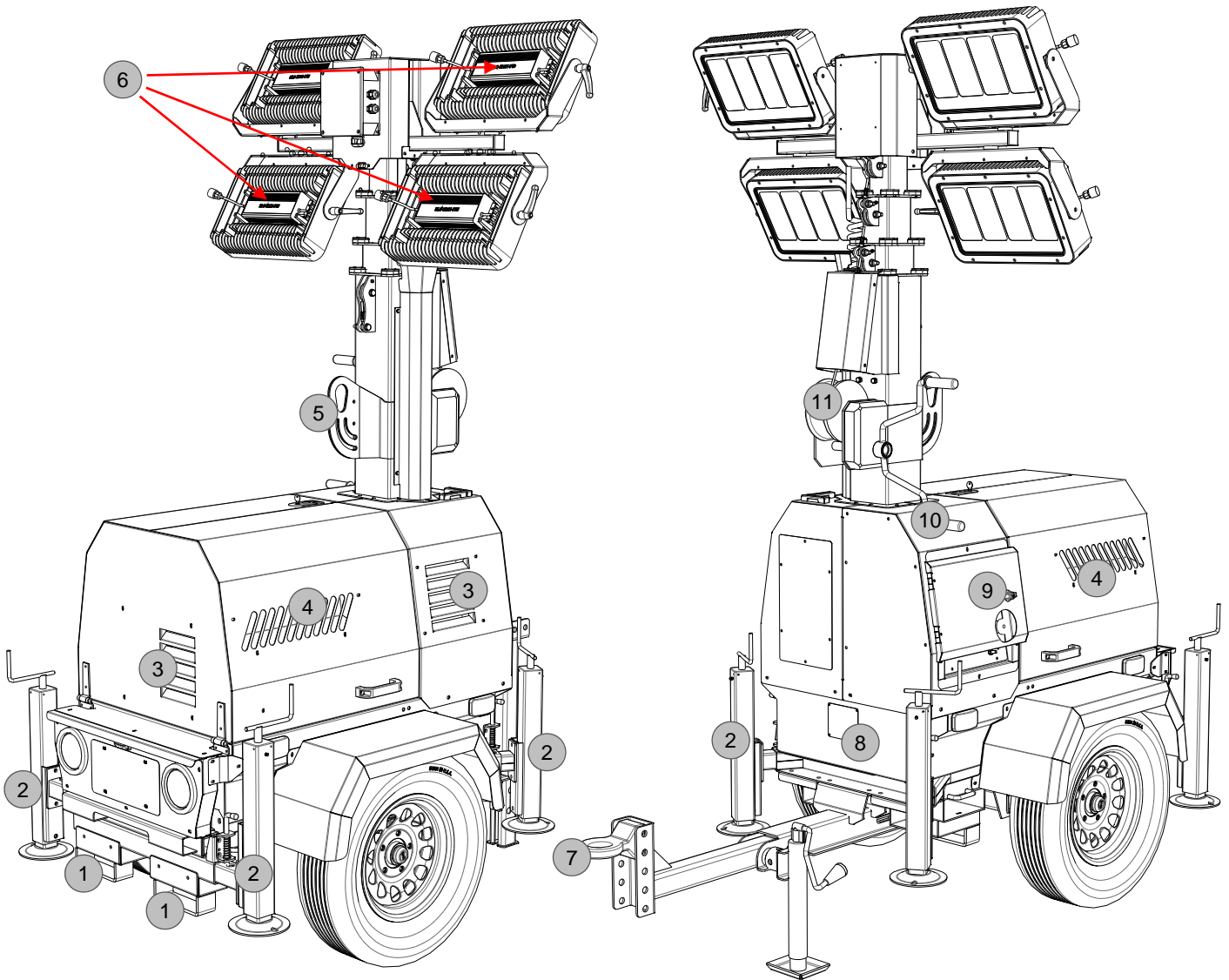

1. Fork-lift pockets
2. Extended stabilizers
3. Air inlet
4. Air output
5. Lifting eye
6. Floodlight power supplies
7. Tow bar hook
8. Data plate
9. Control panel inspection door
10. Winch handle
11. Winch

MACHINE FEATURES



1. DSE L401 controller
2. Power supply switch
3. Main breaker (15A)
4. Lamp switches
5. Emergency stop button
6. Earthing terminal
7. Fuel filter
8. Fuel filter / Water separator
9. Oil filter
10. Air filter
11. Oil level dipstick / Oil filler cap
12. Fuel filler cap
13. Starting motor
14. Battery charger regulator
15. Oil drain pump
16. AC pump
17. Battery

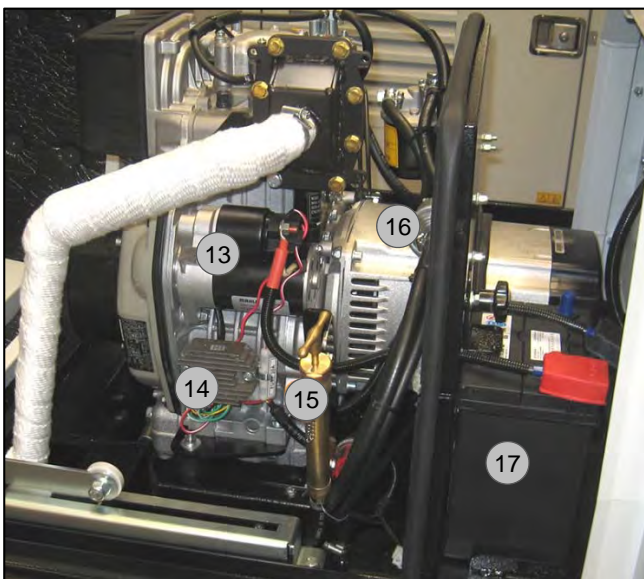
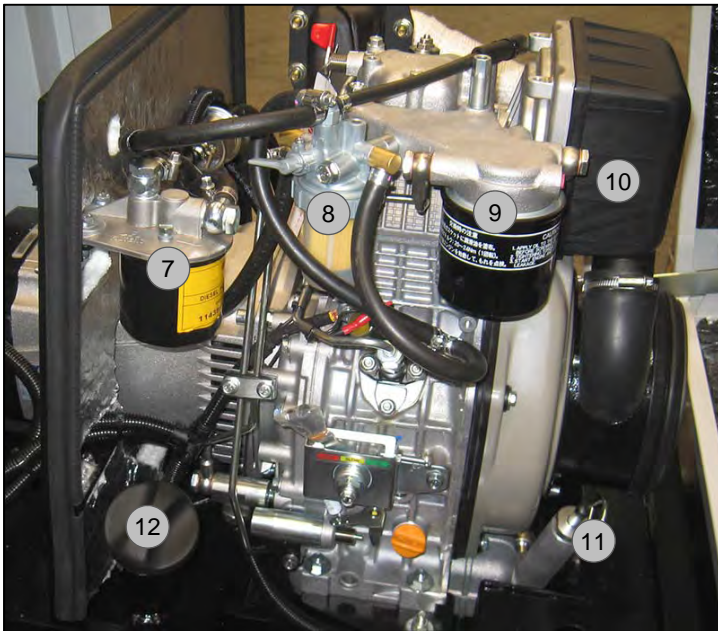

## HANDLING AND TRANSPORT

### TOWING & MOVING WITH TOWING VEHICLE



**Do not move the trailer with the tower raised!**

**NEVER** release the jokey wheel or the stabilizer (fixed to the rudder of the trailer) while are supporting the unit! The machine would tip forward and could cause damage or personal injury.

Before coupling the unit to a towing vehicle check the tyres and check that all the lights work properly.

Procedure:

- Turn off the lights and allow time for them to cool.
- Lower the tower.
- Ensure that the stabilizer **(E)** is down so the unit will not tip over when the other stabilizer are raised.
- Raise the stabilizers and retract it.
- Couple the unit to a towing vehicle between the rudder eye **(F)**.
- The unit can be now be towed to the new location.

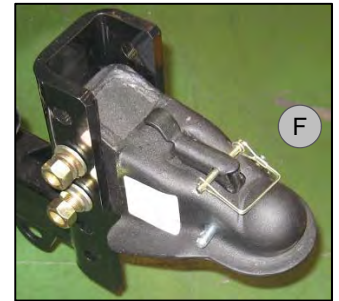
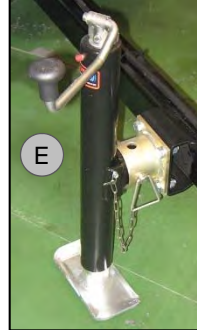

### HANDLING AND TRANSPORT WITH CRANE



**Handling by crane is allowed only if the machine is connected to the crane through the lifting eye.**

- Ensure that the lifting capacity of the crane and lifting devices is suited to the weight of the machine to move. The weight is specified in the provided documentation (user's manual) and on the data plate.
- Connect the cable/hook to the lifting eye **(H)** and tension the cable.
- Lift the machine for about 10 cm (4 in.).
- Move slowly and position the machine on the ground or on the vehicle.



## HANDLING AND TRANSPORT

### HANDLING AND TRANSPORT WITH FORKLIFT

- Ensure that the lifting capacity of the forklift is suited to the weight of the machine to move. The weight is specified in the provided documentation (user's manual) and on the data plate.
- Insert the forks into the forklift pockets (I).
- Lift the machine for about 10 cm (4 in.).
- Move slowly and position the machine where needed.

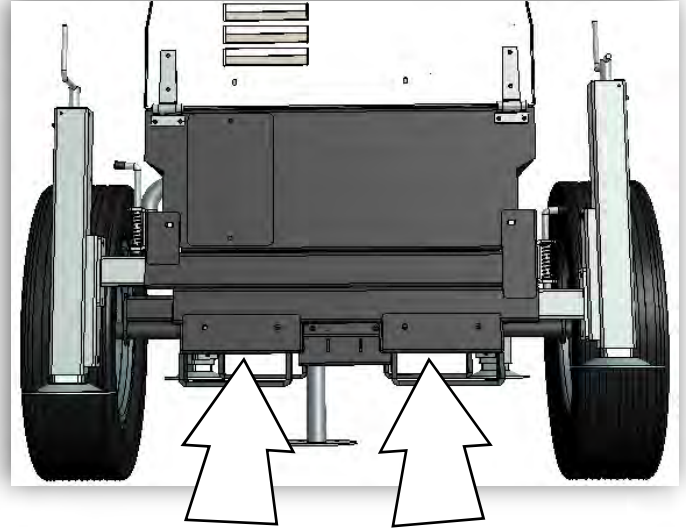
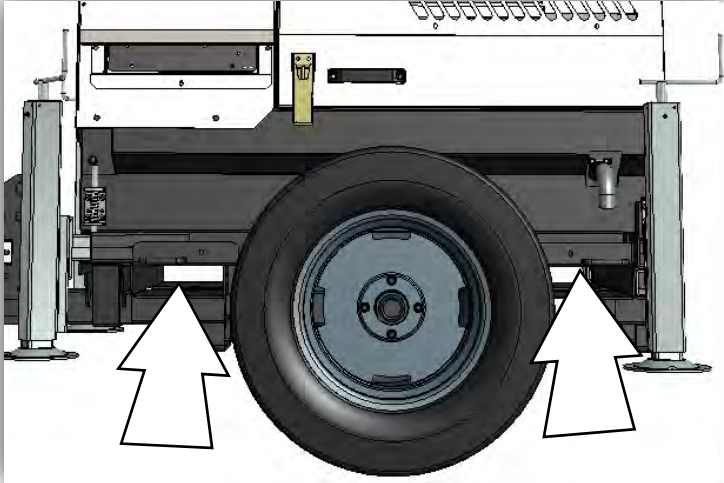

- All lifting operations must be carried out by qualified personnel, such as fork lift operators, crane operators and slingers. The operator should be deemed responsible for using the correct method of slinging and lifting the generator unit.
- Never leave the load insecure.
- When moving and transporting the machine, do not tilt it excessively.
- When lifting and moving the machine, do not stay or walk within it's proximity.
- Never leave the machine slung overhead.

## LIGHTING TOWER USE

### STABILIZING THE UNIT

Jack up the unit as follows. Consider that the stabilizers are extendable **(M)**.

- Hold the stabilizer with one hand and pull the locking pin to release it. Pull the stabilizer outwards until it's fully extended and ensure that the locking pin locked it in place securely in the extended position.
- Jack the unit up by rotating the handle on the top of each stabilizer clockwise.
- Please refer to the bubble levels **(N)** installed on top of the machine (near the mast) in order to have the machine perfectly leveled and stable before rising the tower.
- The wheels of the machine have to touch the ground at all times.

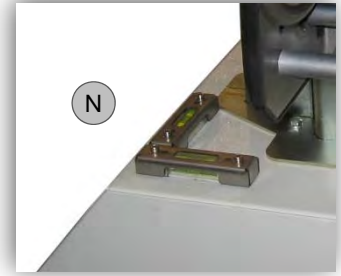

### DIRECTING THE FLOODLIGHTS

Each of the LEDs can be adjusted on two axes and tilted back and forth. This way the lights can be directed either vertically or horizontally. In order to adjust the light on the vertical axes, the encircled pin **(P)** needs to be unlocked by pulling it and then turning the floodlight. For any adjustments, the mast must be lowered to allow access.

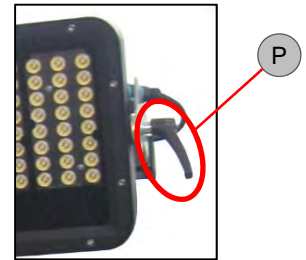

### PRELIMINARY CHECK & STARTING

Before starting and operating the unit, we suggest making the following routine checks for improved safety, better efficiency, longer product life and in order to avoid work disruptions.

- Check that the machine is leveled correctly and stabilized firmly.
- Check that all the lamp lenses are clean and undamaged.
- After adjusting the lights, prepare to raise the tower by:
  - Inspecting the cable and replacing it, if damaged.
  - Checking mounting hardware for proper tightness and re-torquing if necessary.
- Check fuel, engine oil and coolant level. Top them if necessary.
- Ensure that the fuel lines are undamaged and correctly connected.
- Ensure that all the electrical cables are undamaged and correctly connected.
- Check that the main switch and the circuit breakers are in the OFF position.
- Ensure that all the light switches are turned off in order not to start the engine under load.
- Drive the earth picket into the ground (earth) following any risk assessment. (\*)
- Check that the grounding cable is securely attached to the unit.
- Check that the emergency stop button is not pressed. If necessary, rotate the button clockwise to release it.
- Open the frontal door to access the control panel.

For operators' safety, the grounding of the machine always needs to be done paying attention on the section of the cable to be used (never to be less than 10 mm<sup>2</sup>). For the connection of the grounding cable, please always use the clip located on the control panel, on the right side of the machine. Always perform grounding operations in compliance with local/international regulations.

The following section details the function and meaning of the various controls on the module.

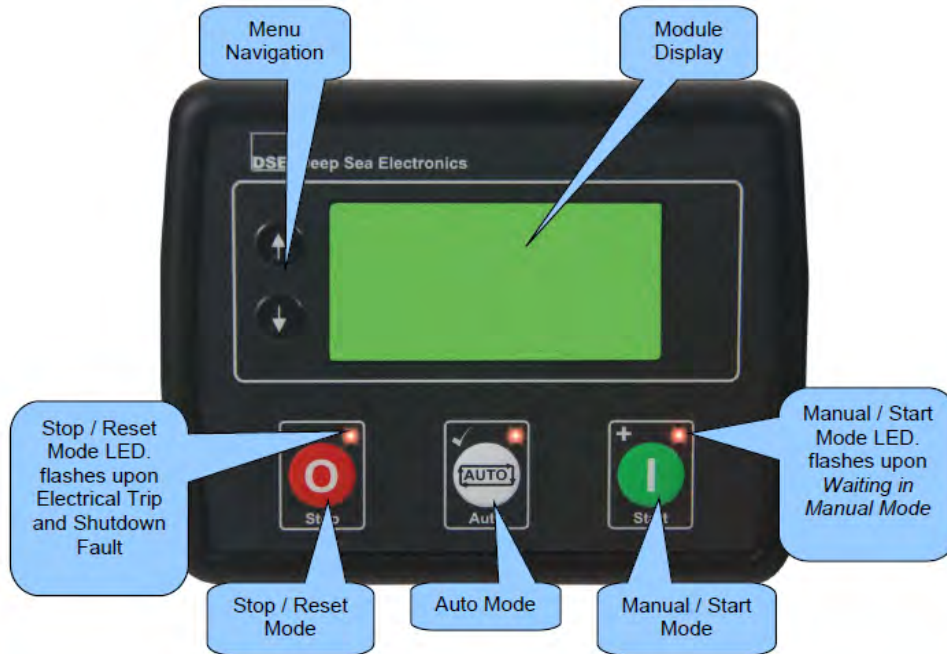

#### STOP/RESET MODE

This button places the module into its **Stop/Reset Mode**. This clears any alarm conditions for which the triggering criteria have been removed. If the engine is running and the module is put into Stop mode, the module automatically instructs the generator to unload. The fuel supply de-energises and the engine comes to a standstill. Should any form of **remote start signal** be present while operating in this mode, a start does not occur.



#### AUTO MODE

This button places the module into its **Auto Mode**. This mode allows the module to control the function of the generator automatically. The module monitors the **Remote Start** input once a start request is made, the set is automatically started and placed on load. Upon removal of the starting signal, the module removes the load from the generator and shut the set down observing the Stop Delay timer and Cooling Down timer as necessary. The module then awaits the next start event.



#### MANUAL/START MODE

This button starts the engine and runs it on.



#### MENU NAVIGATION

Used for navigating the instrumentation, event log and configuration screens. For further details, see the more detailed section of Operation elsewhere in this manual.



## LIGHTING TOWER USE



















### DSE L401 CONTROL UNIT: MODULE DISPLAY



















The module's display contains the following sections. Description of each section are viewed in the sub sections.

<b>Inst. Icon</b>	Instrumentation	Unit	<b>Alarm Icon</b>
<b>Active Config</b>	Instrumentation	Unit	
<b>Auto Run</b>	Instrumentation	Unit	<b>Mode / FPE Icon</b>
<b>Light Output Icons</b>			

### DSE L401 CONTROL UNIT: INSTRUMENTATION ICONS

When viewing instrumentation pages, an icon is displayed in the **Inst. Icon** section to indicate what section is currently being displayed.

Icon	Description
	The default home page which displays generator voltage instrumentation screen
	Generator voltage and frequency instrumentation screen
	Current and load instrumentation screen
	Engine speed instrumentation screen
	Hours run instrumentation screen
	Battery voltage instrumentation screen
	Coolant temperature instrumentation screen
	Oil pressure instrumentation screen
	Fuel level instrumentation screen
	Flexible sensor instrumentation screen
	Oil Filter maintenance timers
	Air Filter maintenance timers
	Fuel Filter maintenance timers
	Current time held in the unit
	Current setting of the scheduler start time and duration
	Appears when the event log is being displayed
	ECU diagnostic trouble codes
	Appears when the main configuration is selected

Icon	Description
	Appears when the alternative configuration is selected
	Appears when a remote start input is active
	Appears when a low battery run is active
	Appears when a scheduled run is active
	Appears when the engine is at rest and the unit is in stop mode
	Appears when the engine is at rest and the unit is in auto mode
	Appears when the engine is at rest and the unit is waiting for a manual start
	Appears when a timer is active, for example cranking time, crank rest etc.
	Appears before starting or when the preheat timer is active
	Appears when the warming up timer is active
	Appears when the engine is running, and all timers have expired, either on or off load. The animation speed is reduced when running in idle mode
	Appears when the unit is in the configuration editor
	Appears when the unit is in the operator editor
	Appears when the corresponding light output has been configured and is not active
	Appears when the corresponding light output has been configured and is not active
	Appears when a timer to delay the light output activating or de-activating is in progress
	Appears when a configuration is being written to the module via the USB connection
	Appears if either the configuration file or engine file becomes corrupted



## LIGHTING TOWER USE

### DSE L401 CONTROL UNIT: ALARM ICONS (PROTECTIONS)

An icon is displayed in the **Alarm Icon** section to indicate the alarm that is current active on the controller.

In the event of a warning alarm, the LCD only displays the **Alarm Icon**. In the event of an electrical

trip or shutdown alarm, the module displays the **Alarm Icon** and the **Stop/Reset Mode**  button LED begins to flash.

If multiple alarms are active at the same time, the **Alarm Icon** automatically cycles through all the appropriate icons to indicate each alarm which is active.

#### Example:



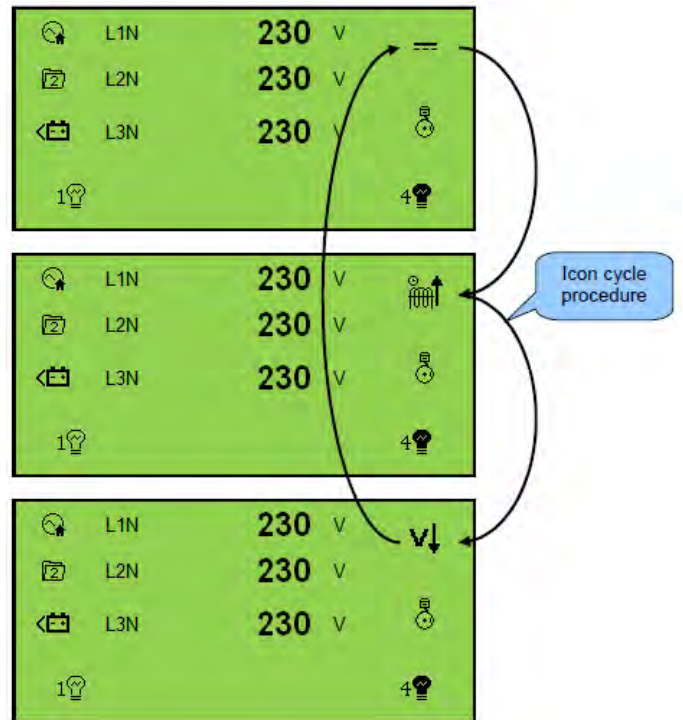















If the DSE controller was sensing a charge alternator failure alarm, delay over current alarm and a AC under voltage alarm at the same time, it would cycle through all of the icons to show this.



## LIGHTING TOWER USE

### DSE L401 CONTROL UNIT: WARNING ALARM ICONS

Warnings are non-critical alarm conditions and do not affect the operation of the generator system, they serve to draw the operators attention to an undesirable condition.













Description	
	<b>Auxiliary Inputs</b> The module detects that an auxiliary input which has been user configured to create a fault condition has become active.
	<b>Analogue Input Configured As Digital</b> The module detects that an analogue input configured as a digital input to create a fault condition has become active.
	<b>Fail To Stop</b> The module has detected a condition that indicates that the engine is running when it has been instructed to stop. <b>NOTE: 'Fail to Stop' could indicate a faulty oil pressure sensor. If engine is at rest check oil sensor wiring and configuration.</b>
	<b>Charge Failure</b> The auxiliary charge alternator voltage is low as measured from the W/L terminal.
	<b>Low Fuel Level</b> The level detected by the fuel level sensor is below the low fuel level setting.
	<b>Battery Under Voltage</b> The DC supply has fallen below or risen above the low volts setting level.
	<b>Battery Over Voltage</b> The DC supply has risen above the high volts setting level.
	<b>Generator/Mains Under Voltage</b> The generator output voltage has fallen below the pre-set pre-alarm setting after the Safety On timer has expired. Or, the mains output voltage has fallen below the pre-set pre-alarm setting when the <i>Mains Supply Active</i> is active.
	<b>Generator/Mains Over Voltage</b> The generator/mains output voltage has risen above the pre-set pre-alarm setting.
	<b>Generator/Mains Under Frequency</b> The generator output frequency has fallen below the pre-set prealarm setting after the Safety On timer has expired. Or, the mains output frequency has fallen below the pre-set prealarm setting when the <i>Mains Supply Active</i> is active.
	<b>Generator/Mains Over Frequency</b> The generator/mains output frequency has risen above the pre-set pre-alarm setting.
	<b>CAN ECU Fault</b> The engine ECU has detected an alarm.
	<b>CAN Data Fail</b> The module is configured for CAN operation and does not detect data on the engine CAN data link.
	<b>Immediate Over Current</b> The measured current has risen above the configured trip level.
	<b>Delayed Over Current</b> The measured current has risen above the configured trip level for a configured duration.
	<b>Low Current</b> The measured current has fallen below the configured trip level. This is used to detect lamp failure.
	<b>Oil Filter Maintenance Alarm</b> Maintenance due for oil filter.
	<b>Air Filter Maintenance Alarm</b> Maintenance due for air filter.
	<b>Fuel Filter Maintenance Alarm</b> Maintenance due for fuel filter.













## LIGHTING TOWER USE

### DSE L401 CONTROL UNIT: SHUTDOWN ALARM ICONS

Shutdown alarms are latching and immediately stop the Generator. On initiation of the shutdown condition the module de-energises all the 'Light Output' outputs to remove the load from the generator. Once this has occurred, the module shuts the generator set down immediately to prevent further damage. The alarm must be accepted and cleared, and the fault removed to reset the module.



Shutdowns are latching alarms and to remove the fault, press the **Stop/Reset Mode**  button on the module.

	Description	
	<b>Auxiliary Inputs</b>	The module detects that an auxiliary input which has been user configured to create a fault condition has become active.
	<b>Analogue Input Configured As Digital</b>	The module detects that an analogue input configured as a digital input to create a fault condition has become active.
	<b>Fail To Start</b>	The engine has failed to start after the configured number of start attempts
	<b>Low Oil Pressure</b>	The module detects that the engine oil pressure has fallen below the low oil pressure pre-alarm setting level after the Safety On timer has expired.
	<b>Engine High Coolant Temperature</b>	The module detects that the engine coolant temperature has exceeded the high engine temperature pre-alarm setting level after the Safety On timer has expired.
	<b>Under Speed</b>	The engine speed has fallen below the under speed pre alarm setting
	<b>Over Speed</b>	The engine speed has risen above the over speed pre alarm setting
	<b>Charge Failure</b>	The auxiliary charge alternator voltage is low as measured from the W/L terminal.
	<b>Low Fuel Level</b>	The level detected by the fuel level sensor is below the low fuel level setting.
	<b>Battery Under Voltage</b>	The DC supply has fallen below or risen above the low volts setting level.
	<b>Battery Over Voltage</b>	The DC supply has risen above the high volts setting level.
	<b>Generator/Mains Under Voltage</b>	The generator output voltage has fallen below the pre-set prealarm setting after the Safety On timer has expired. Or, the mains output voltage has fallen below the pre-set pre-alarm setting when the <i>Mains Supply Active</i> is active.
	<b>Generator/Mains Over Voltage</b>	The generator/mains output voltage has risen above the pre-set pre-alarm setting.



	Description	
	<b>Generator/Mains Under Frequency</b>	The generator output frequency has fallen below the pre-set prealarm setting after the Safety On timer has expired. Or, the mains output frequency has fallen below the pre-set prealarm setting when the <i>Mains Supply Active</i> is active.
	<b>Generator/Mains Over Frequency</b>	The generator/mains output frequency has risen above the pre-set pre-alarm setting.
	<b>CAN ECU Fault</b>	The engine ECU has detected an alarm – CHECK ENGINE LIGHT Contact Engine Manufacturer for support.
	<b>CAN Data Fail</b>	The module is configured for CAN operation and does not detect data on the engine CAN data link.
	<b>Emergency Stop</b>	The emergency stop button has been depressed. This failsafe (normally closed to emergency stop) input and immediately stops the set when the signal be removed.
	<b>Oil Pressure Sensor Open Circuit</b>	The oil pressure sensor has been detected as being open circuit.
	<b>Coolant Temperature Sensor Open Circuit</b>	The coolant temperature sensor has been detected as being open circuit.
	<b>Delayed Over Current</b>	The measured current has risen above the configured trip level for a configured duration.
	<b>Low Current</b>	The measured current has fallen below the configured trip level. This is used to detect lamp failure.
	<b>Oil Filter Maintenance Alarm</b>	Maintenance due for oil filter.
	<b>Air Filter Maintenance Alarm</b>	Maintenance due for air filter.
	<b>Fuel Filter Maintenance Alarm</b>	Maintenance due for fuel filter.

## LIGHTING TOWER USE

### DSE L401 CONTROL UNIT: NAVIGATION MENU

To enter the navigation menu, press the **Up**  and **Down**  buttons simultaneously.





To select the required icon, press the **Up**  button to cycle right or the **Down**  button to cycle left until the desired instrumentation section is reached.



Once the desired icon is at the top, press the **Auto Mode**  button to enter that instrumentation section.

If the **Auto Mode** button is not pressed, the display automatically returns to the Home page after the configured setting of the *LCD Scroll Timer*.

It is possible to scroll through the display to view different pages of information by repeatedly operating the **Up**  and **Down**  navigation buttons.







Example:

To view one of the instrument pages towards the end of the list, it may be quicker to scroll up through the pages rather than down!



And so on until the last page is reached. A Further press of the **Down** navigation button returns the display to the Home page. Once selected, the page remains on the LCD display until the user selects a different page or, after an extended period of inactivity (*Page Delay Timer*), the module reverts back to the Home page.

#### NAVIGATION MENU ICONS

Icon	Description
	Home, generator / mains voltage and frequency instrumentation
	Load current and load instrumentation
	Engine instrumentation
	Module information
	Mast and light control
	Engine DTCs (Diagnostic Trouble Codes) if active
	Event Log

### HOME PAGE

This is the page that is displayed when no other page has been selected and is automatically displayed after a period of inactivity (*Page Delay Timer*) of the module facia buttons. It also contains the voltage reading of the generator (alternator) measured from the module's voltage inputs.

- Generator Voltage (ph-N)
- Generator Voltage (ph-ph)

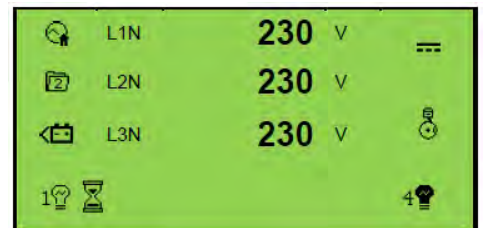

### ENGINE PAGE

These pages contain instrumentation gathered about the engine measured or derived from the module's inputs, some of which may be obtained from the engine ECU.

- Engine Speed
- Engine Run Time
- Engine Battery Volts
- Engine Coolant Temperature
- Engine Oil Pressure
- Engine Fuel Level or Flexible Sensor
- Engine Maintenance Due – Oil
- Engine Maintenance Due – Air
- Engine Maintenance Due – Fuel

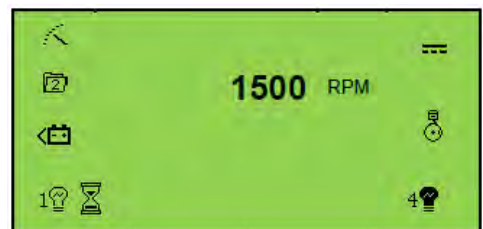

**LIGHTING TOWER USE**

**GENERATOR PAGE**

**NOTE: Generator instrumentation is only displayed when the *Mains Supply Active* digital input is not active. When the *Mains Supply Active* digital input is active, the Generator instrumentation is replaced with Mains instrumentation.**

These pages contain electrical values of the generator (alternator), measured or derived from the module's voltage and current inputs.

- Generator Voltage (ph-ph)
- Generator Frequency
- Generator Current
- Generator Load per Phase (kW)
- Generator Total Load (kW)
- Generator Load per Phase (kV A)
- Generator Total Load (kV A)
- Generator Load per Phase (kvar)
- Generator Total Load (kvar)
- Generator Power Factor per Phase
- Generator Power Factor Average
- Generator Accumulated Load (kW h, kVA h, kvar h)



**MAINS PAGE**

**Mains instrumentation is only displayed when the *Mains Supply Active* digital input is active. When the *Mains Supply Active* digital input is not active, the Mains instrumentation is replaced with Generator instrumentation.**

These pages contain electrical values of the mains, measured from the module's voltage and current inputs.

- Mains Voltage (ph-ph)
- Mains Frequency
- Mains Current
- Mains Load per Phase (kW)
- Mains Total Load (kW)
- Mains Load per Phase (kV A)
- Mains Total Load (kV A)
- Mains Total Load (kW)
- Mains Load per Phase (kvar)
- Mains Total Load (kvar)
- Mains Power Factor per Phase
- Mains Power Factor Average



**INFO PAGE**

These pages contain information about the controller.

- Module's date and time
- Scheduler settings
- Product description and USB identification number
- Application and Engine Version

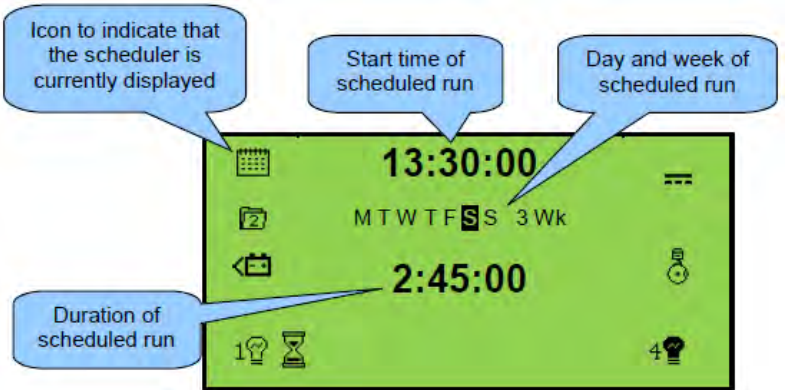

DSE L401 CONTROL UNIT: SCHEDULER EDITING FROM INSTRUMENTATION SCREENS

The DSE module allows editing of the scheduler from the instrumentation screen whilst in **Stop/Reset Mode**  without needing to enter the *Front Panel Editor*. This is only possible when *Scheduler Edit From Fascia* is enabled in the module's configuration.

Scheduler Edit From Fascia

Enabling the *Scheduler Enable From Fascia* option in the DSE module configuration adds two pages on the module's display. This allows the user to enable/disable the Scheduler and to select the Schedule period.

Scheduler Enable From Fascia

To access the scheduler editor, navigate to one of the scheduler pages and press and hold the **Stop/Reset Mode** button .

Use the **Stop/Reset Mode**  (-) or **Manual/Start Mode**  (+) buttons to cycle through the editor.



To edit the parameters press the **Auto Mode**  button and then use the **Stop/Reset Mode** (-) or **Manual/Start Mode** (+) buttons to change the value.

The displayed value or icon begins to flash to show it is being edited. Press the **Auto Mode** button to accept the new value. Press and hold **Auto Mode** button to exit the editor and save the changes.

The scheduler pages on the instrumentation screen list the following for 8 scheduled start/stop sequence.

1. Scheduler Enable option, icons detailed below.





Icon	Description
	Select to disable the <i>Scheduler</i>
	Select to enable the <i>Scheduler</i>

2. Schedule Period to indicate *Weekly*, *Monthly*, or *Daily*.



3. Run Mode, icons detailed below.



Icon	Description
	Select for <i>Off Load</i> .
	Select for <i>On Load</i> .
	Select for <i>Lights Only</i> .

4. Start time (00:00:00).

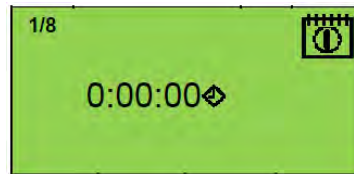

5. Start Day. Select the day of the week (1=Monday, 2=Tuesday, 3=Wednesday, 4=Thursday, 5=Friday, 6=Saturday, 7=Sunday).

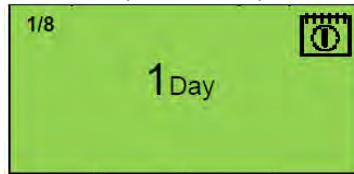

6. Start Week. Select the week of month (1,2,3,4).



7. Duration (00:00:00).

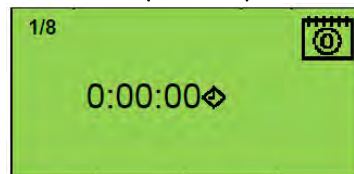

If the DSE module is connected to an ECU, This page contains active *Diagnostic Trouble Codes (DTC)* only if the engine ECU generating a fault code. These are alarm conditions are detected by the engine ECU and displayed by the DSE controller.

To view the engine DTC(s), press the **Up** and **Down** buttons simultaneously to enter the navigation menu. Once entered, cycle to the **DTC** section using the **Up** or **Down** buttons and press the **Auto Mode** button to enter.

To view the active DTC(s) alarms, repeatedly press **Up** or **Down** buttons until the LCD screen displays the alarm. Continuing to press the **Up** or **Down** buttons cycles through the other DTC alarms.

To exit the active DTC(s) alarm section, press the **Up** or **Down** buttons simultaneously to enter the navigation menu. Once entered, cycle to the desired instrumentation section using the **Up** or **Down** buttons and press the **Auto Mode** button to enter.

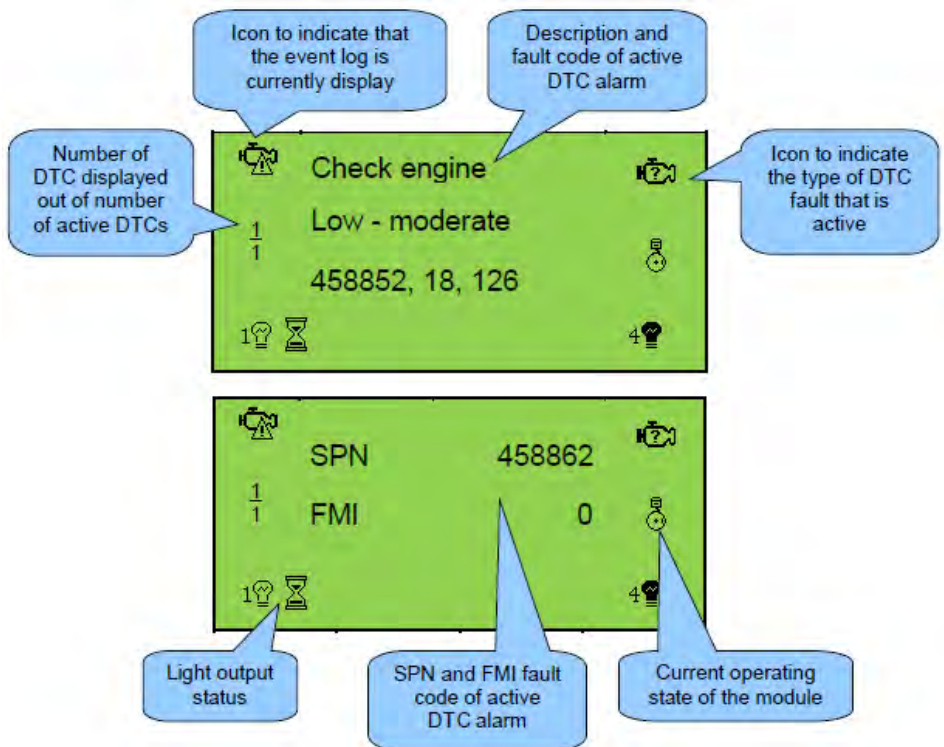

These pages contain information about the timer (scheduler).

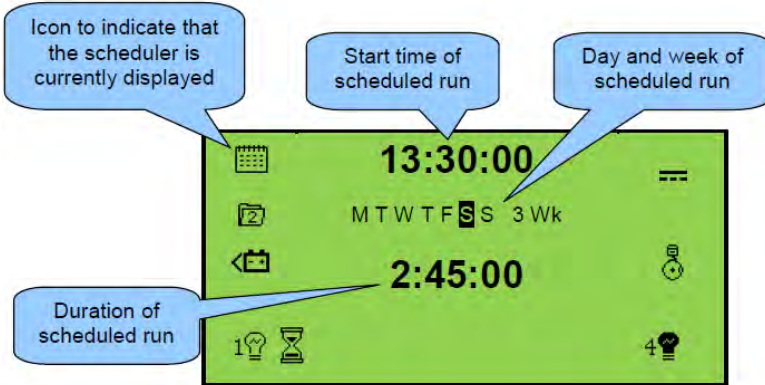

### SCHEDULER EDITING FROM INSTRUMENTATION SCREENS

The DSE module allows editing of the scheduler from the instrumentation screen whilst in **Stop/Reset Mode**

without needing to enter the *Front Panel Editor*. This is only possible when *Scheduler Edit From Fascia* is enabled in the module's configuration.

To access the scheduler editor, navigate to one of the scheduler pages and press and hold the

**Stop/Reset Mode**

button. Use the **Stop/Reset Mode**

**Manual/Start Mode**

(+) buttons to cycle through the editor. To edit the parameters press the **Auto Mode**

(v) button and then use the **Stop/Reset Mode**

**Manual/Start Mode**

(+) buttons to change the value. The displayed value or icon begins to flash to show it is being edited.

Press the **Auto Mode**

button to accept the new value. Press and hold **Auto Mode**

(v) button to exit the editor and save the changes.



LIGHTING TOWER USE

DSE L401 CONTROL UNIT: TIMER

The scheduler pages on the instrumentation screen list the following for 8 scheduled start/stop sequence.

Scheduler Enable option, icons detailed below.



Icon	Description
	Select to disable the Scheduler.
	Select to enable the Scheduler.

Schedule Period to indicate Weekly, Monthly, or Daily.



Run Mode, icons detailed below.



Icon	Description
	Select for Off Load.
	Select for On Load.
	Select for Lights Only.

Start time (00:00:00).

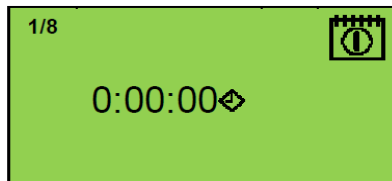

Start Day. Select the day of the week (1=Monday, 2=Tuesday, 3=Wednesday, 4=Thursday, 5=Friday, 6=Saturday, 7=Sunday)

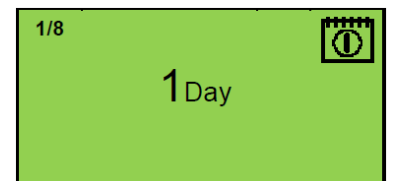

Start Week. Select the week of month (1,2,3,4).



Duration (00:00:00).

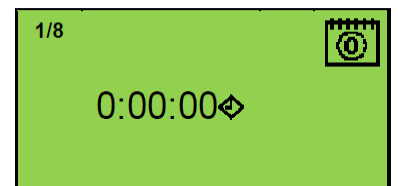

## ROUTINE MAINTENANCE

Poorly maintained equipment can become a safety hazard. In order, for the equipment, to operate safely and properly over a long period of time, periodic maintenance and occasional repairs are necessary.

**Any kind of maintenance work on the lighting tower must be carried out by Authorized and trained personnel.** It should be done in a safe working environment and with the machine well stabilized. The engine must be turned off and let cool down sufficiently before starting to work on it.

- While performing maintenance work, please use suitable tools and clothes.
- If you need to work while the engine is running, pay attention to all moving parts, hot parts and electrical parts which may be unprotected while the machine is open.**
- DO NOT modify any component if not authorized.

The repairs cannot be considered among the routine maintenance activities. E.g. the replacement of parts that are subject to occasional damage and the replacement of electric and mechanic components that wear with use. This kind of work is not –in fact– covered by warranty.

**The periodic maintenance should be performed according to the documentation provided by the engine and alternator manufacturers. Please refer to the relevant manual supplied with the machine and to the hour meter on the machine in order to determine when service is needed.**

---

## DISPOSAL AND DECOMMISSIONING

This machine is made of parts that, if not disposed of correctly, can damage the environment and create ecological hazards. The following parts and materials need to be brought to authorized waste treatment sites:

- Metallic structure;
- Batteries;
- Engine and hydraulic oils;
- Cooling liquid;
- Filters;
- Cables.

**These components have to be disposed of accordingly to local laws and dispositions.** Have qualified personnel disassemble the machine and dispose of parts.

The machine owner is responsible for dismantling and disposal of the machine and its components at the end of its working life.

---



## SPARE PARTS

### FLOODLIGHTS

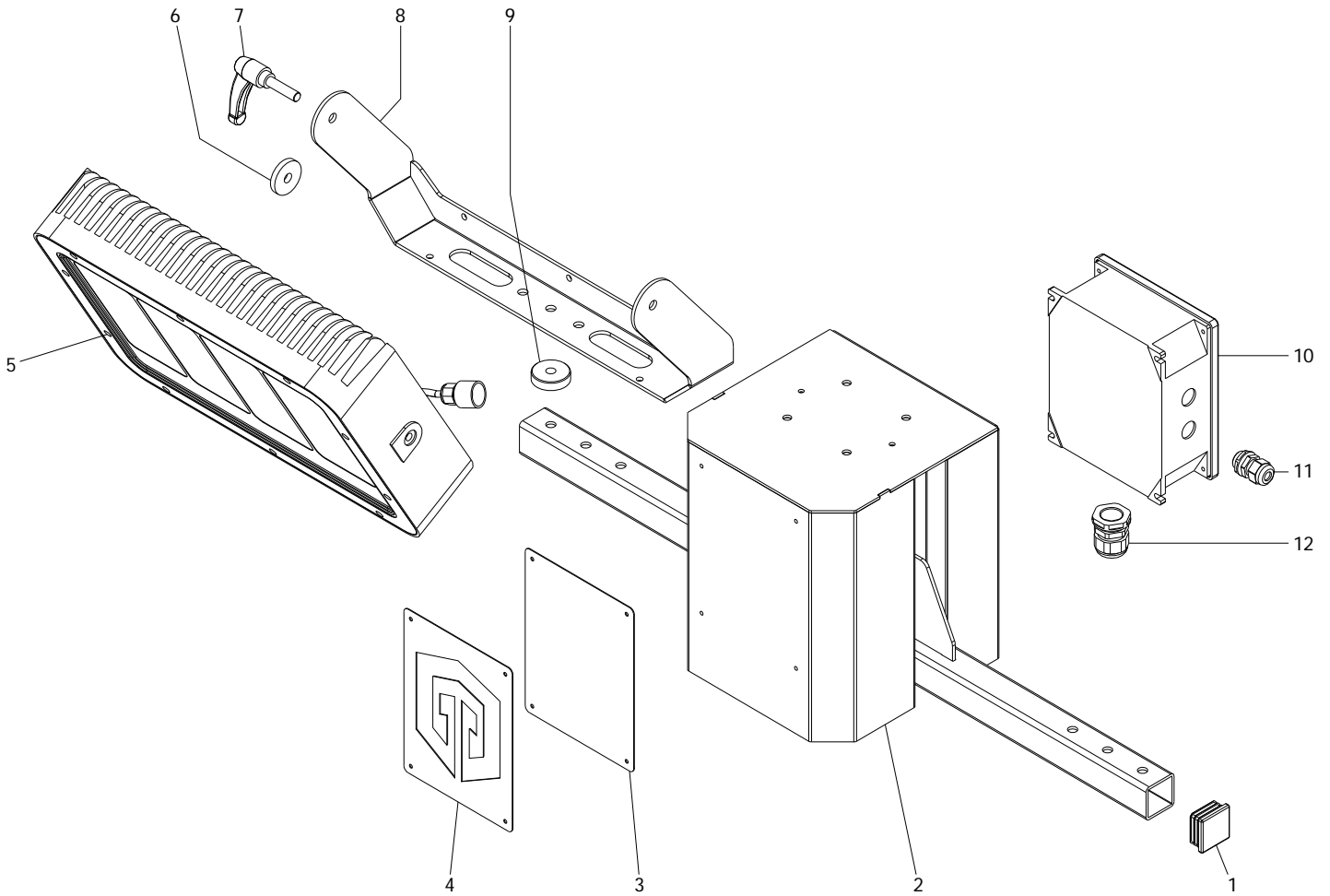

N.	CODE	DESCRIPTION
1	AC000_P037_021	CAP
2	LED04_C000_113	CENTRAL SUPPORT
3	LO_C041_009	RED PLATE
4	LO_C041_008	LOGO PLATE
5	AC000_E026_089	FLOODLIGHT
6	LED04_C000_012	SPACER
7	AC000_M000_076	HANDLE
8	LED04_C000_092ZN	FLOODLIGHT SUPPORT
9	AS000_M023_025	SPACER
10	AS000_E006_052	JUNCTION BOX
11	AC000_E018_008	PG11 WIRE HOLDER
12	AC000_E018_002	PG21 WIRE HOLDER

STEEL ROPES AND PULLEYS

N.	CODE	DESCRIPTION	
1	AC000_M021_009	STEEL ROPE	L.4300mm
2	AC000_M021_006	STEEL ROPE	L.1415mm
3	AC000_M021_013	STEEL ROPE	L.1460mm
4	AC000_M021_011	STEEL ROPE	L.1455mm
5 (*)	AC000_M021_002	PULLEY	D.60
	AC000_M021_003	PULLEY	D.62
	AC000_M021_008	PULLEY	D.63
6	AS000_M000_029	SCREW	

(*)	PLEASE AT THE TIME OF THE ORDER MEASURE THE DIAMETER
-----	---

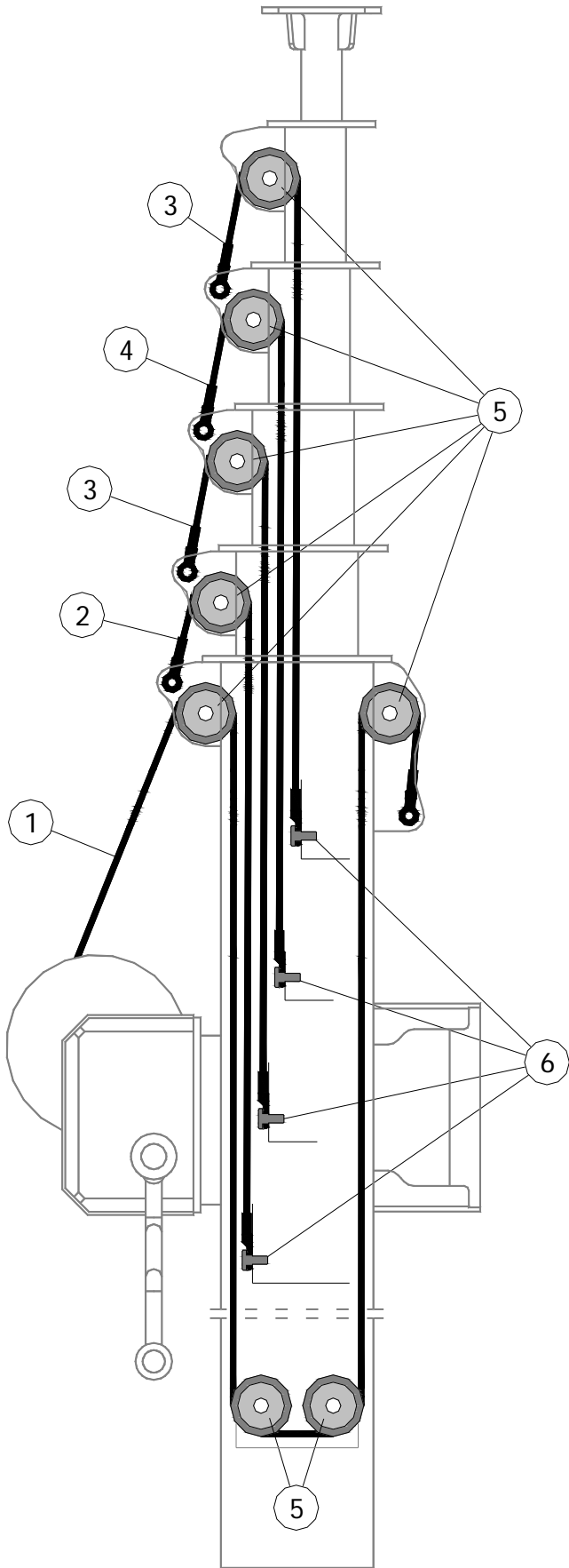

SPARE PARTS

MAST

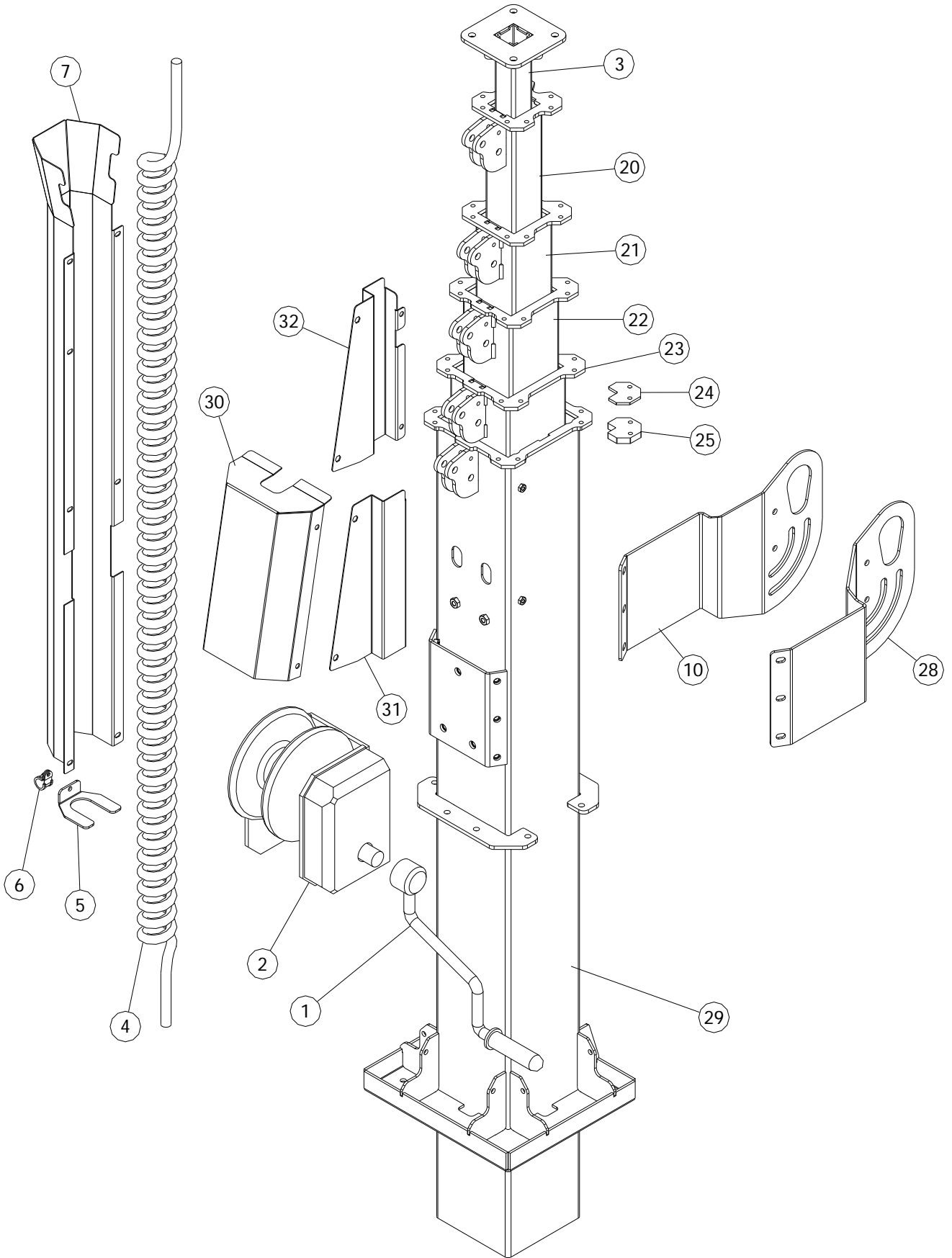

**SPARE PARTS**

<b>N.</b>	<b>CODE</b>	<b>DESCRIPTION</b>
1	AC000_M000_084_01	WINCH HANDLE
2	AC000_M000_084	WINCH BODY
3	PFM08_C000_006ZN	6° SECTION MAST
4	AC000_E006_016	COILED CABLE
5	PFM08_C000_047	COILED CABLE BOTTOM PLATE
6	AC000_M038_007	RUBBERED CLAMP
7	PFM08_C031_088ZN	COILED CABLE PROTECTION
10	PFM07_C031_049ZN	LIFTING EYE, LEFT PART
20	PFM08_C000_005ZN	5° SECTION MAST
21	PFM08_C000_004ZN	4° SECTION MAST
22	PFM08_C000_003ZN	3° SECTION MAST
23	PFM08_C000_002ZN	2° SECTION MAST
24	PFI08_C031_012ZN	RUNNER REINFORCEMENT
25	AS000_M000_005	ANGULAR RUNNER
28	PFM07_C031_048ZN	LIFTING EYE, RIGHT PART
29	PFM08_C031_087ZN	1° SECTION MAST
30	PFM08_C000_018	PROTECTION
31	PFM08_C000_019	PROTECTION RIGHT BRACKET
32	PFM08_C000_020	PROTECTION LEFT BRACKET

SPARE PARTS

BASE

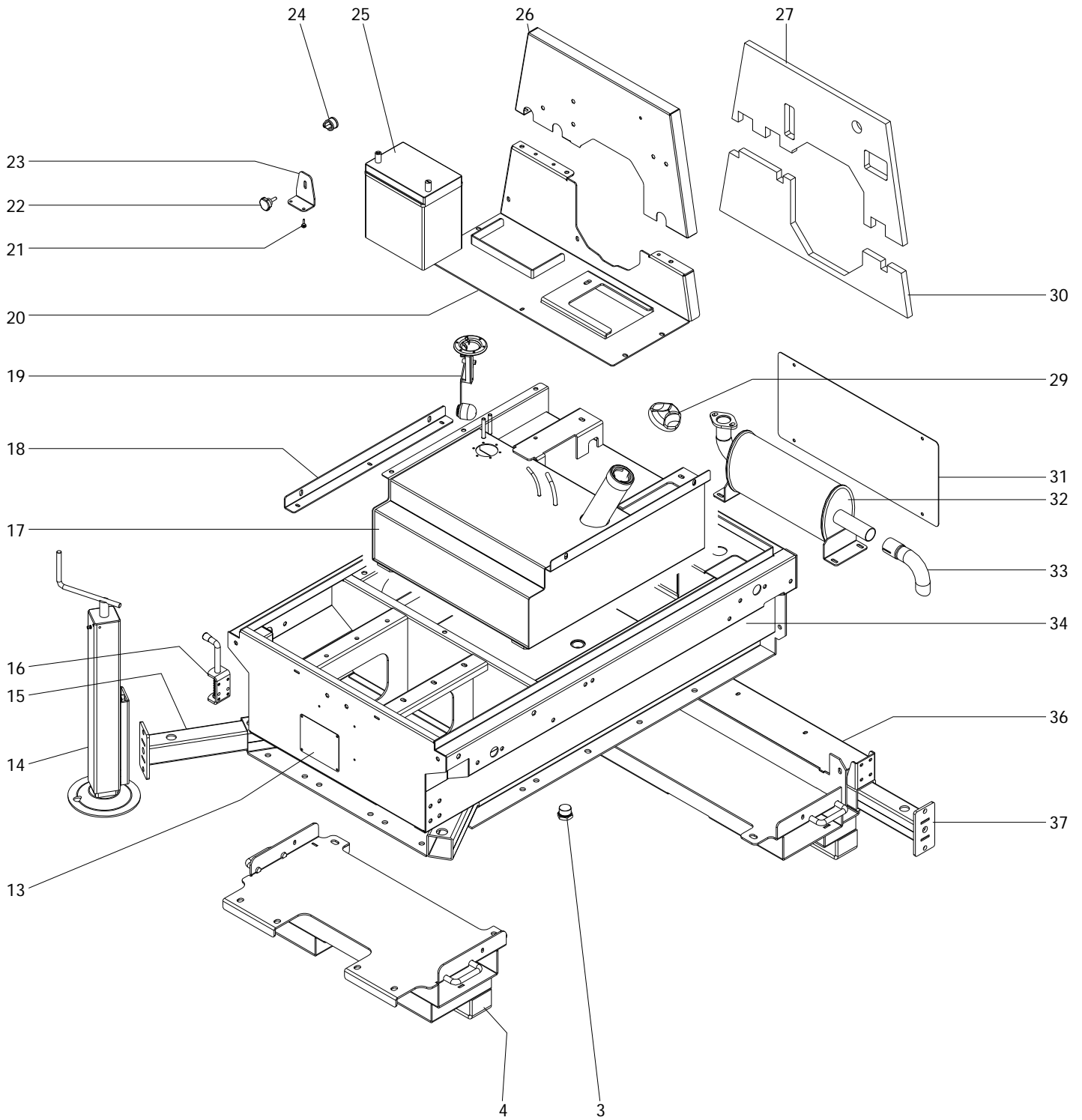



**SPARE PARTS**

<b>N.</b>	<b>CODE</b>	<b>DESCRIPTION</b>
3	AC000_M000_081	DRAIN CAP
4	XMI2_C003_105	FRONT FORK-LIFT POCKET
13	XMI2_S010_192B	DATA PLATE
14	AS000_M000_048	STABILIZER
15	XMI2_C000_004ZN	FRONT STABILIZER TUBULAR
16	AC000_M000_086	STABILIZER LOCKING PIN
17	XMI2_C005_183	FUEL TANK
18	XMI2_C005_010	FUEL TANK BRACKET
19	XCY_E006_021	FUEL LEVEL TRANSMITTER
20	XMI2_C004_185	BATTERY PLATFORM
21	AC000_M024_085	BUMPER
22	AC000_M000_158	KNOB
23	XMI2_C000_056	BATTERY BRACKET
24	AC000_M038_052	RUBBERED CLAMP
25	AC000_E000_108	BATTERY
26	XMI2_C004_186	ALTERNATOR SEPARATOR
27	XMI2_AS009_188	COVERING
29	AC000_M000_014	FUEL TANK CAP
30	XMI2_AS009_187	COVERING
31	XMI2_C004_201	REAR COVER
32	XMI2_C035_022	MUFFLER
33	AC000_M000_163	MUFFLER EXTENSION
34	XMI2_C004_179	BASE STRUCTURE
35	XMI2_C004_072	MUFFLER PLATE
36	XMI2_C000_097	REAR FORK-LIFT POCKET
37	XMI2_C000_112ZN	REAR STABILIZER TUBULAR

SPARE PARTS

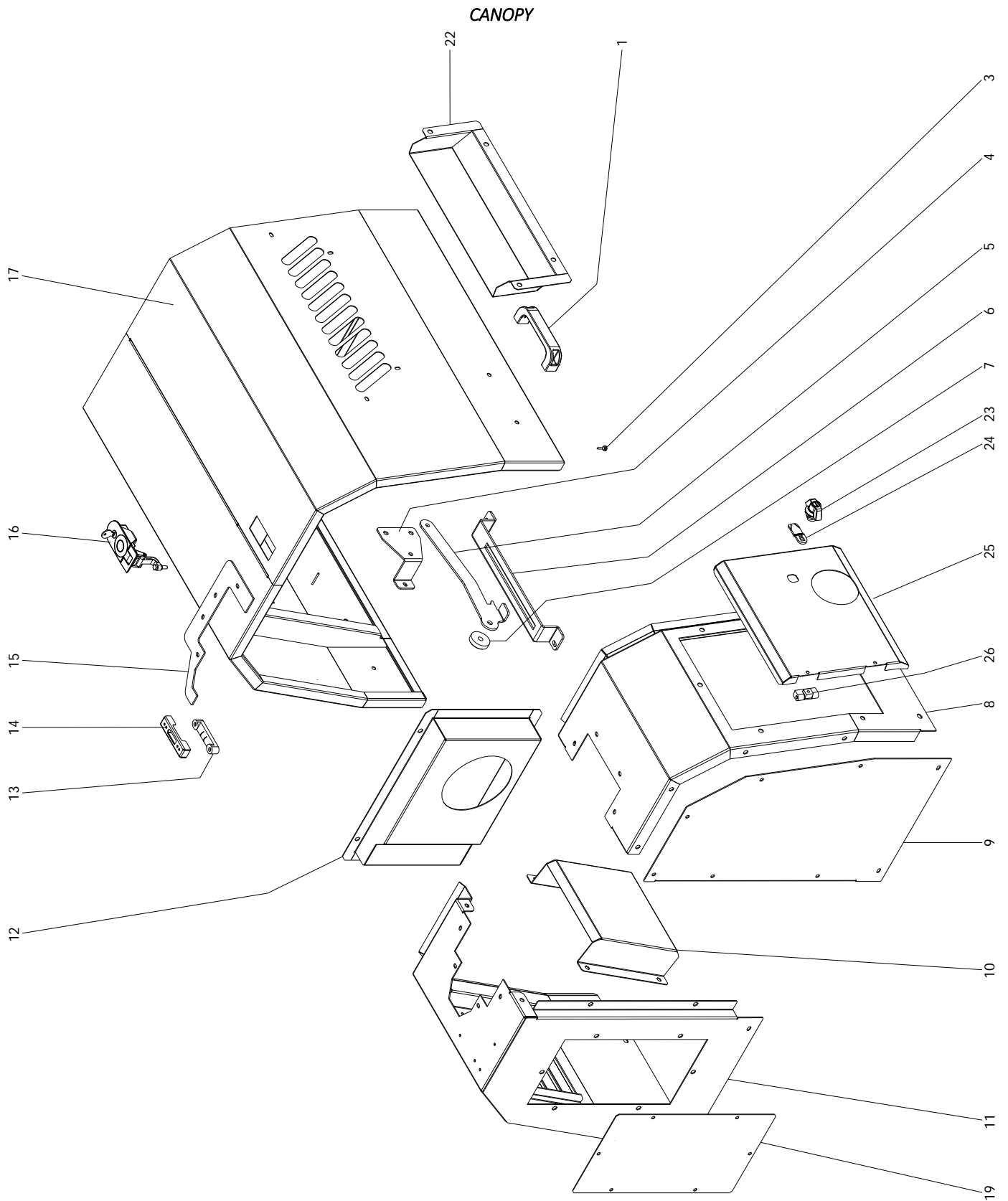

## SPARE PARTS

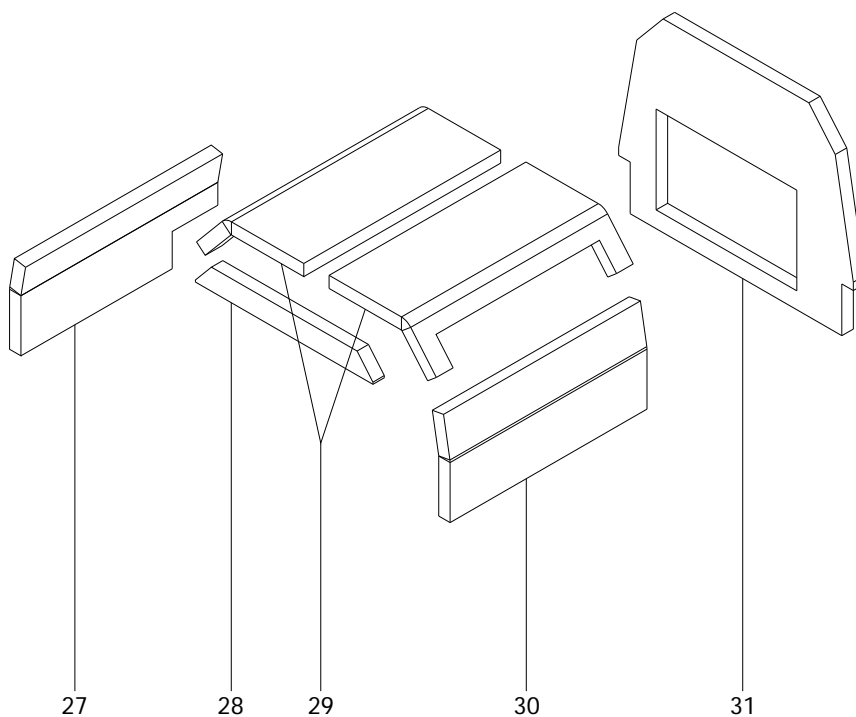

N.	CODE	DESCRIPTION
1	AC000_M000_005	PLASTIC HANDLE
3	AC000_M024_085	BUMPER
4	XMI2_C000_040	CANOPY FIXING BAR BRACKET
5	XMI2_C000_039ZN	CANOPY FIXING BAR HOOK
6	XMI2_C000_038ZN	CANOPY FIXING BAR GUIDE
7	AS000_M023_025	SPACER
8	XMI2_C007_204	RIGHT FRONT CANOPY
9	XMI2_C007_030	RIGHT FRONT CANOPY COVER
10	XMI2_C007_032	AIR DEFLECTOR
11	XMI2_C007_103	LEFT FRONT CANOPY
12	XMI2_C007_194	AIR CONVEYOR
13	AC000_M016_002	BUBBLE LEVEL
14	PFI08_C031_029ZN	BUBBLE LEVEL PROTECTION
15	XMI2_C007_047ZN	MAST PLATE
16	AC000_M000_024	CANOPY HANDLE WITH LOCK
17	XMI2_C007_203	REAR CANOPY
19	XMI2_C000_081	FRONT COVER
21	AC000_M000_008	HINGE
22	XMI2_C007_131	AIR OUTLET DEFLECTOR
23	AC000_M000_168	DOOR LOCK
24	AC000_M000_169	LOCK LEVER
25	XMI2_C008_123	CONTROL PANEL DOOR
26	AC000_M000_053	HINGE
27	XMI2_AS009_189	LEFT SOUNDPROOFING
28	XMI2_AS009_132	FRONT SOUNDPROOFING
29	XMI2_AS009_129	UPPER SOUNDPROOFING
30	XMI2_AS009_127	RIGHT SOUNDPROOFING
31	XMI2_AS009_057	REAR SOUNDPROOFING

SPARE PARTS

TOW BAR, AXLE AND WHEELS

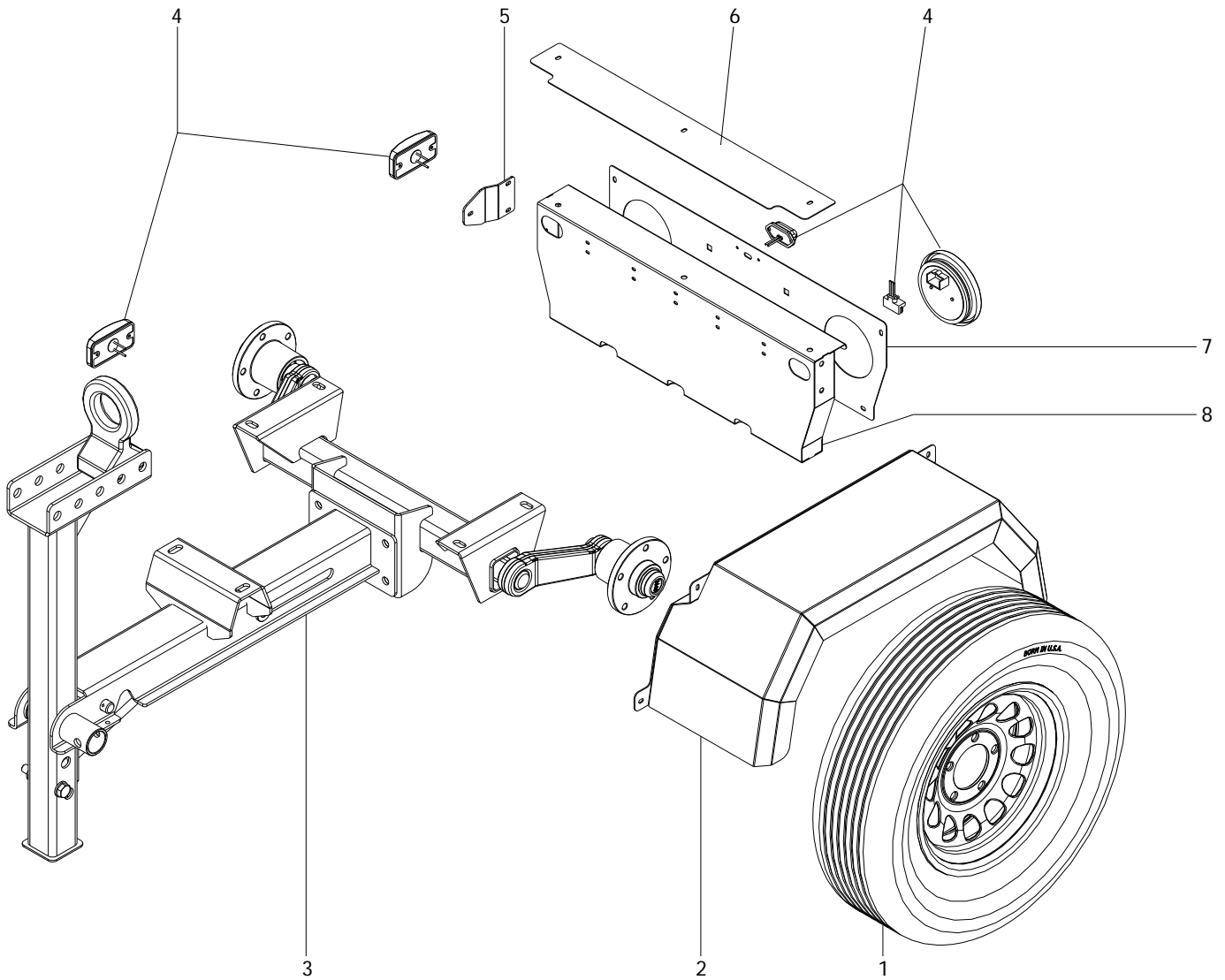

N.	CODE	DESCRIPTION
1	AC000_T003_040	WHEEL
2	XMI2_C004_106	FENDER
3	AC000_T003_041	TOW BAR AND AXLE
4	AC000_E050_137	TRAILER LIGHTS KIT
5	XMI2_C000_199	TAILLIGHTS SUPPORT BRACKET
6	XMI2_C000_200	UPPER COVER
7	XMI2_C000_198	TAILLIGHTS SUPPORT COVER
8	XMI2_C000_197	TAILLIGHTS SUPPORT

## SPARE PARTS

### ENGINE

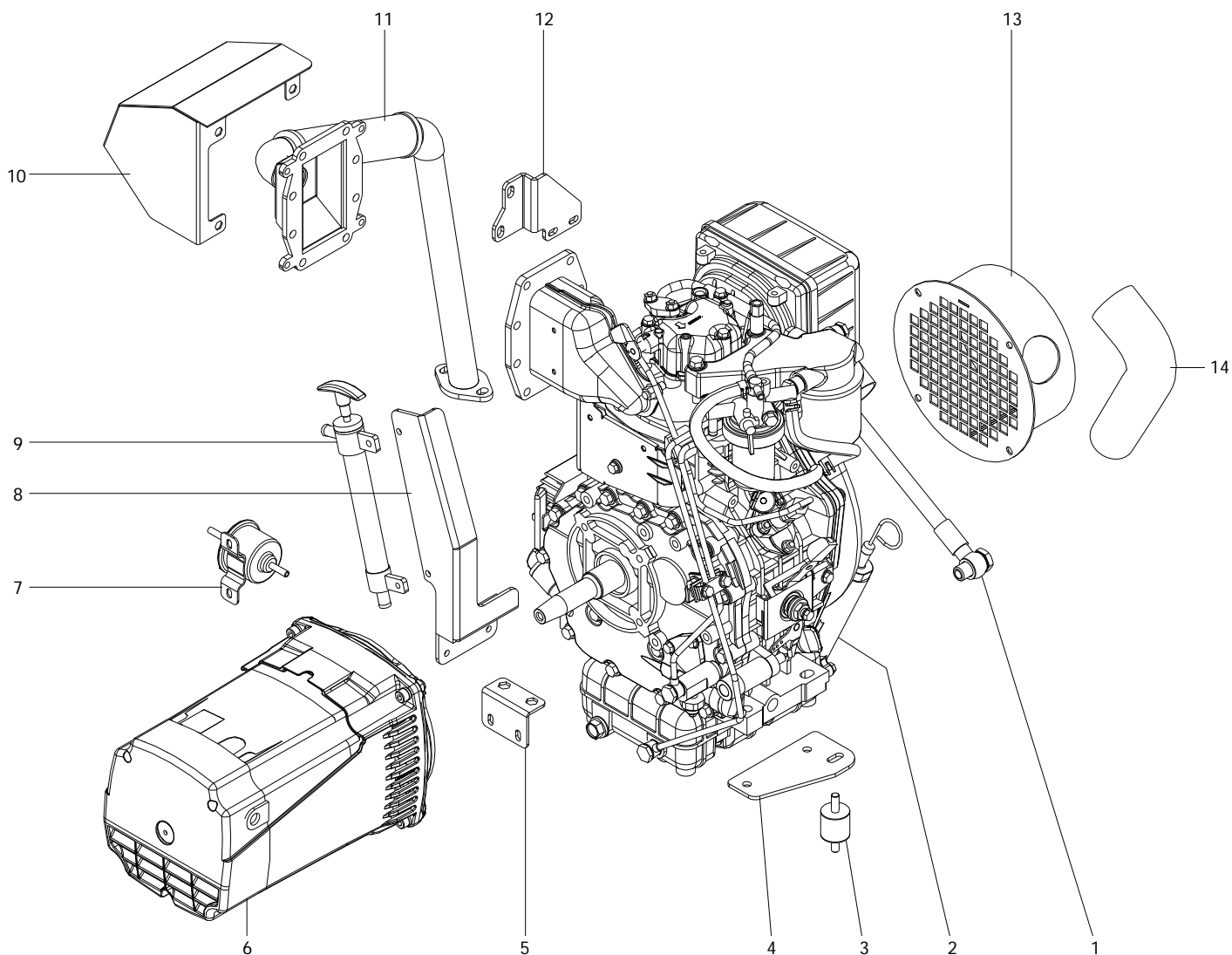

N.	CODE	DESCRIPTION
1	AC000_G001_002	OIL DRAIN PIPE
2	AC000_M033_030	ENGINE
3	AC000_M024_090	SCHOCK ABSORBER
4	XMI2_C001_011	ENGINE SUPPORT
5	XMI2_C007_188	FUEL FILTER SUPPORT
6	AC000_E034_019	ALTERNATOR
7	K-R140151352	CA PUMP
8	XMI2_C001_191	OIL DRAIN PUMP SUPPORT
9	AS000_M000_060	OIL DRAIN PUMP
10	XMI2_C035_190	MUFFLER EXTENSION COVER
11	XMI2_C035_180	MUFFLER EXTENSION
12	XMI2_C035_195	MUFFLER EXTENSION PLATE
13	XMI2_C001_193	AIR CONVEYOR
14	AC000_M001_076	RUBBER SLEEVE

SPARE PARTS

CONTROL PANEL

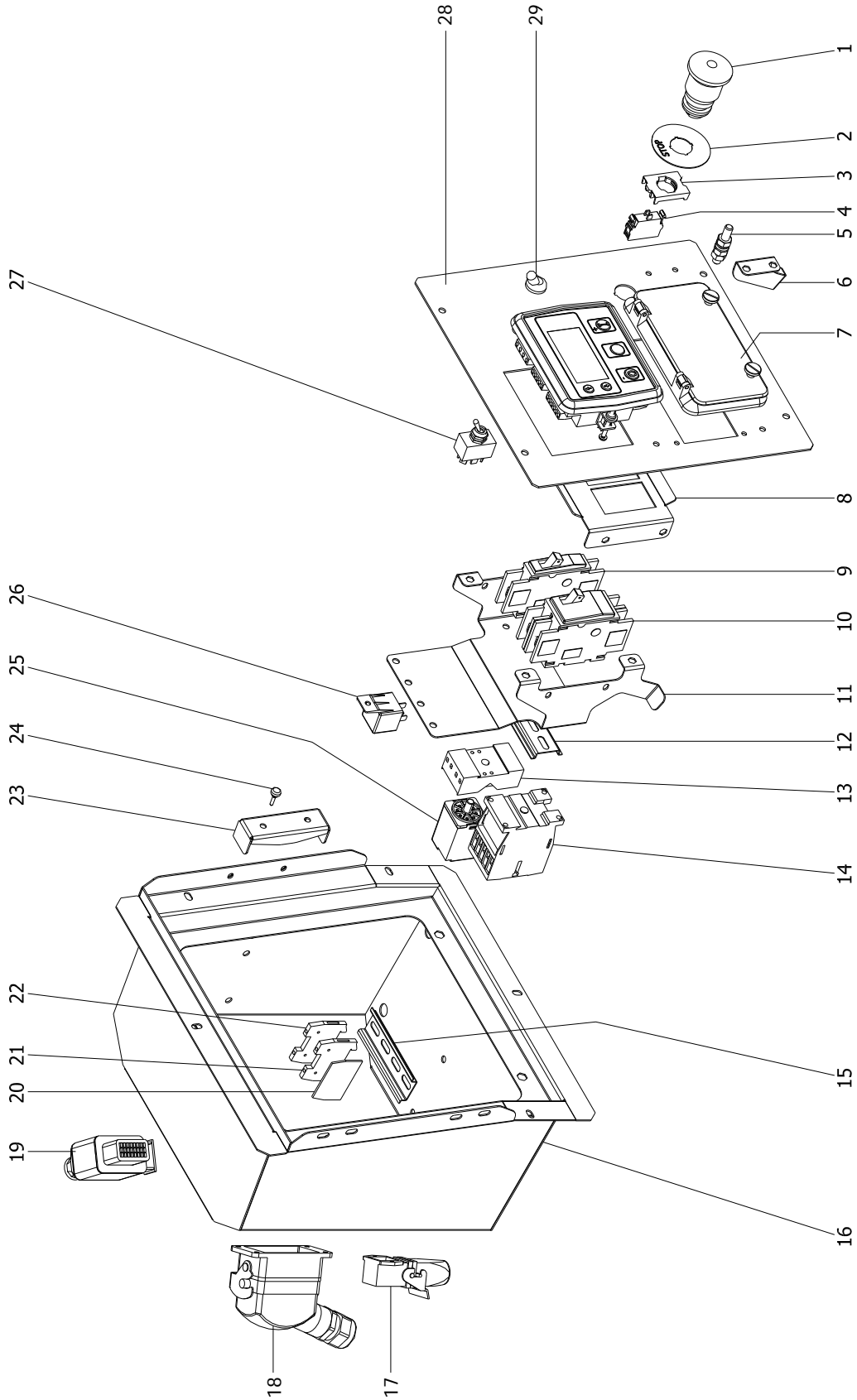

**SPARE PARTS**

<b>N.</b>	<b>CODE</b>	<b>DESCRIPTION</b>
1	AC000_E006_051	STOP BUTTON
2	AC000_E006_053	STOP BUTTON RATING PLATE
3	AC000_E006_043	CONTACTS SUPPORT
4	AC000_E006_052	CONTACT
5	AC000_M038_035	EARTHING TERMINAL
6	XECOK2_C019_232	LOCKING PLATE
7	AC000_E000_025	CIRCUIT BREAKERS COVER
8	XMI2_C006_124	CIRCUIT BREAKERS FRAME
9	AC000_E012_055	LAMP SWITCH
10	AC000_E012_076	MAIN SWITCH
11	XMI2_C006_125	CIRCUIT BREAKERS SUPPORT
12	AC000_M038_057	BAR L.150
13	AC000_E006_133	RELAY 12Vdc BASE
14	AC000_E006_054	CONTACTOR
15	AC000_M038_049	BAR L.100
16	XMI2_C019_120	CONTROL PANEL BOX
17	AC000_G006_005	4 POLES CONNECTOR
18	AC000_G006_004	10 POLES CONNECTOR
19	AC000_G006_003	ENGINE CONNECTOR
20	AC000_E006_024	CLAMP COVER
21	AC000_E006_021	CLAMP
22	AC000_E006_022	FINAL CLAMP
23	XMI2_C008_052	CONTROL PANEL DOOR LOCKING PLATE
24	AC000_M024_085	BUMPER
25	AC000_E006_132	RELAY 12Vdc
26	AC000_E000_040	12V 40A RELAY
27	AC000_E000_016	2 POLES SWITCH
28	XMI2_S010_121B	INSTRUMENTS PLATE
29	AC000_E000_019	SWITCH COVER

ELECTRICAL DIAGRAM

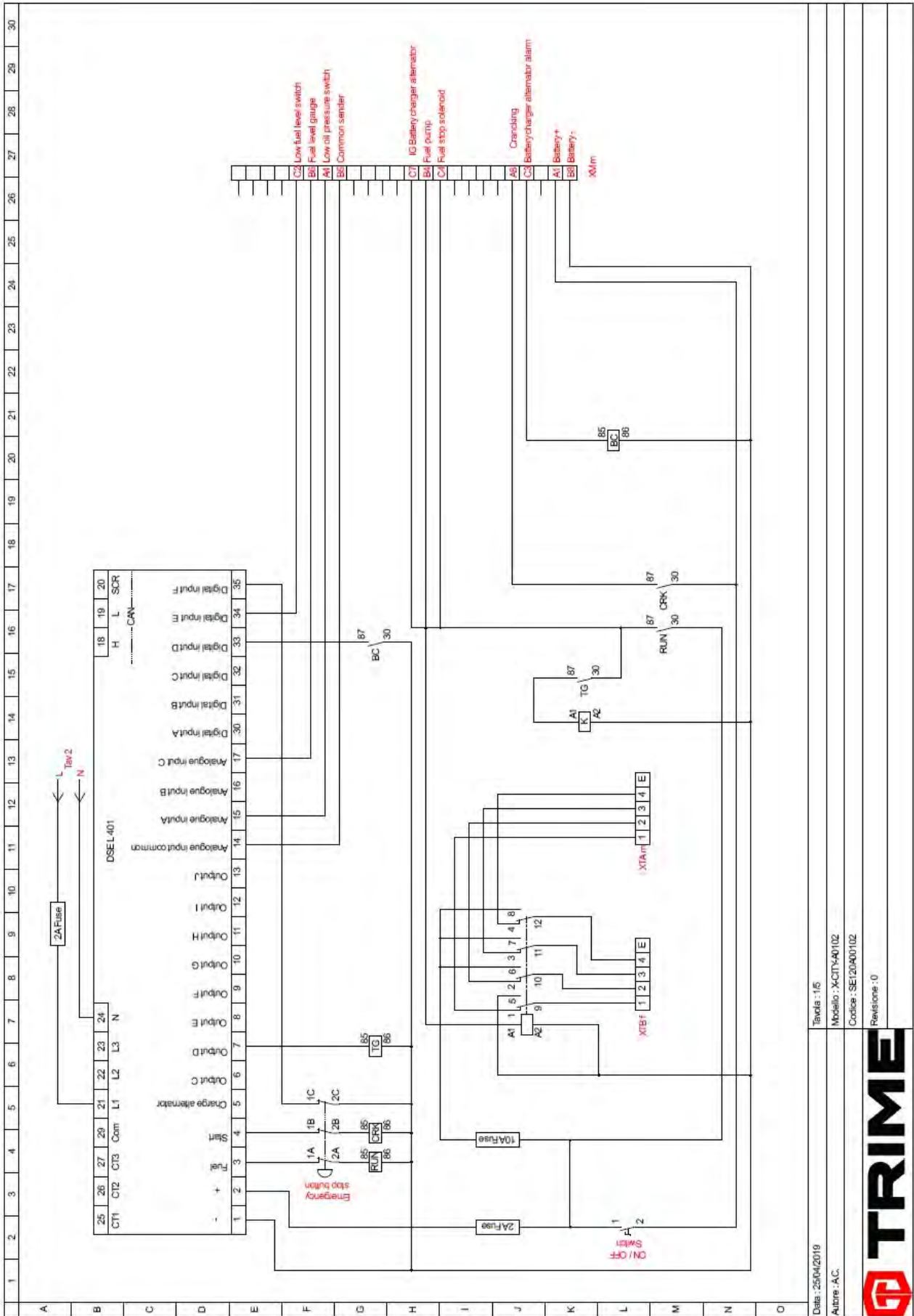

Data : 25/04/2019

Autore : A.C.

Modello : X-CITY-A0102

Codice : SEI20A00102

Revisione : 0





ELECTRICAL DIAGRAM

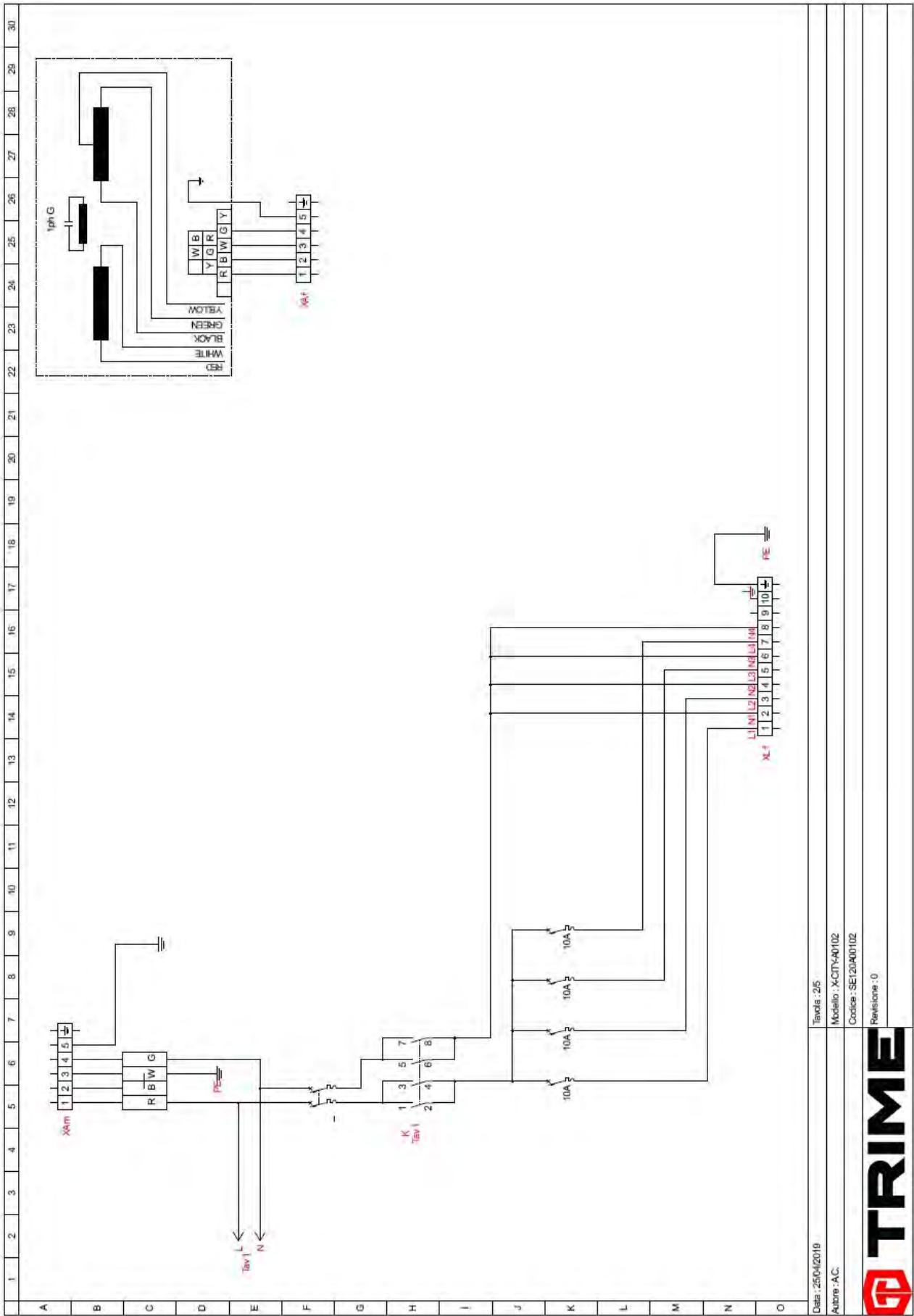

Data: 25/04/2019  
 Autore: AC  
 Tavola: 2/5  
 Modello: X-CITY-A0102  
 Codice: SEI20A00102  
 Revisione: 0



ELECTRICAL DIAGRAM

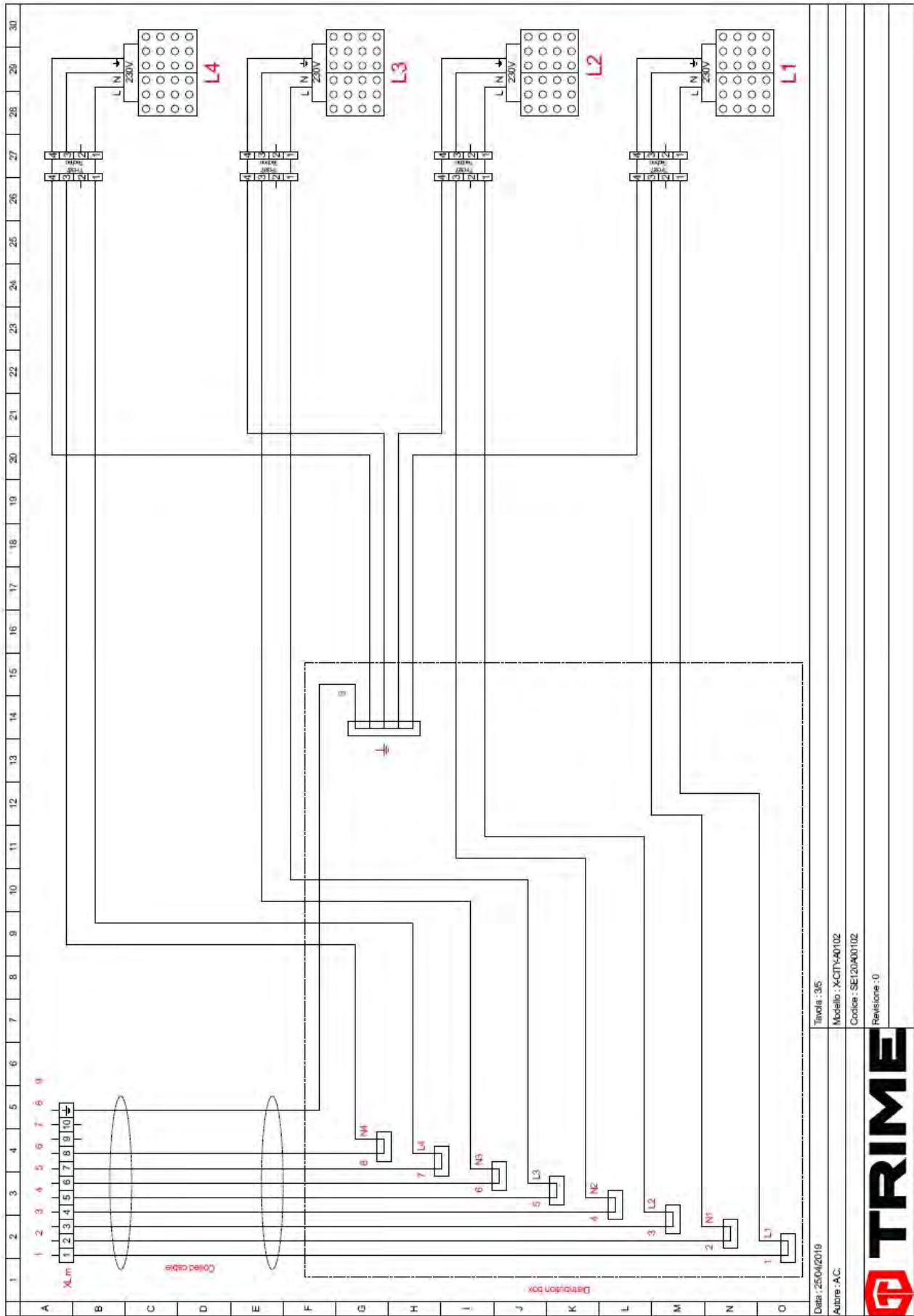

Data : 25/04/2019  
 Autore : A.C.  
 Tavola : 3/5  
 Modello : X-CITY-A0102  
 Codice : SEI20A00102  
 Revisione : 0



ELECTRICAL DIAGRAM

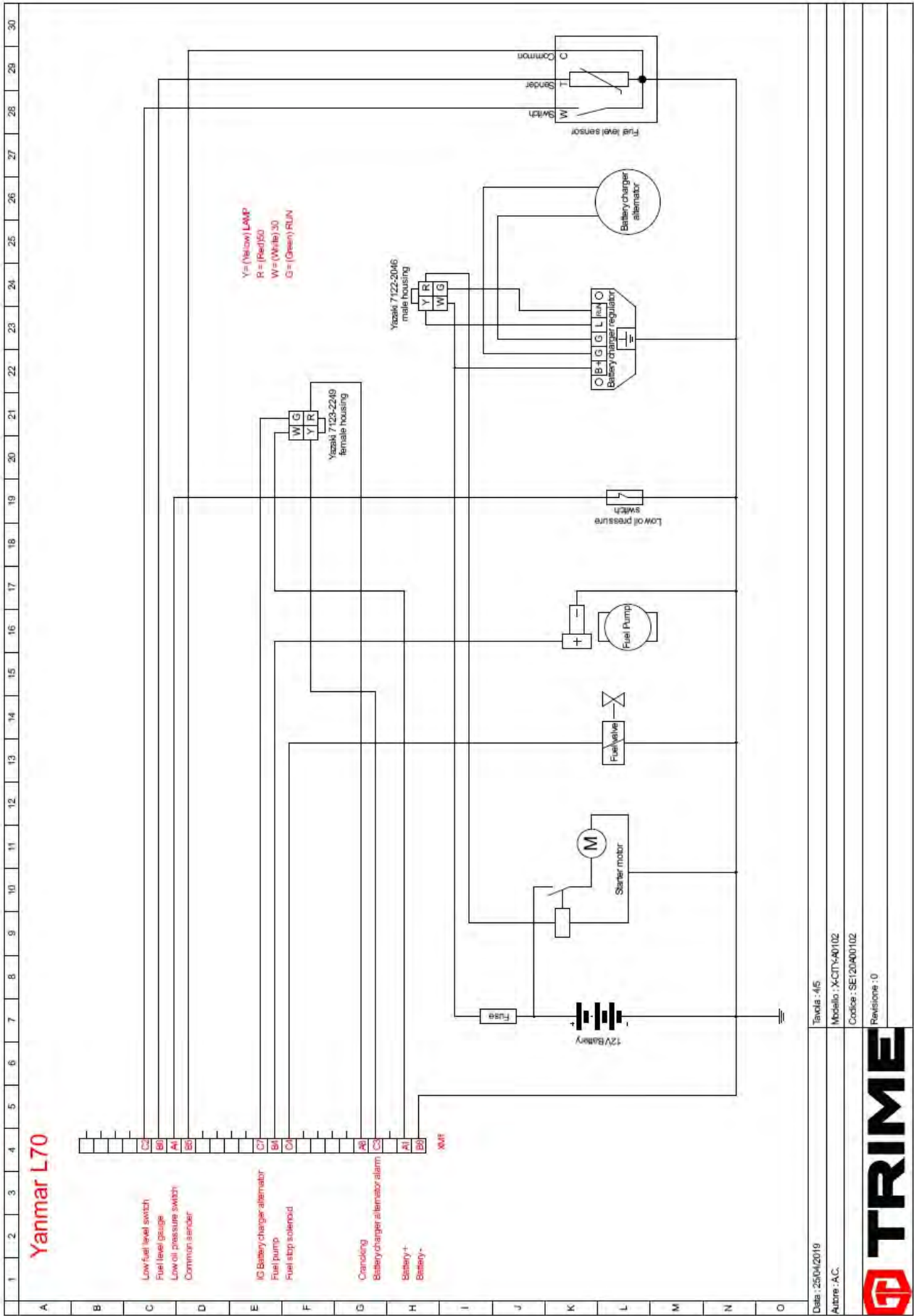

Data : 25/04/2019

Autor : AC

Tavola : 4/5

Modello : X-CTVA0102

Codice : SEI20A00102

Revisione : 0



ELECTRICAL DIAGRAM

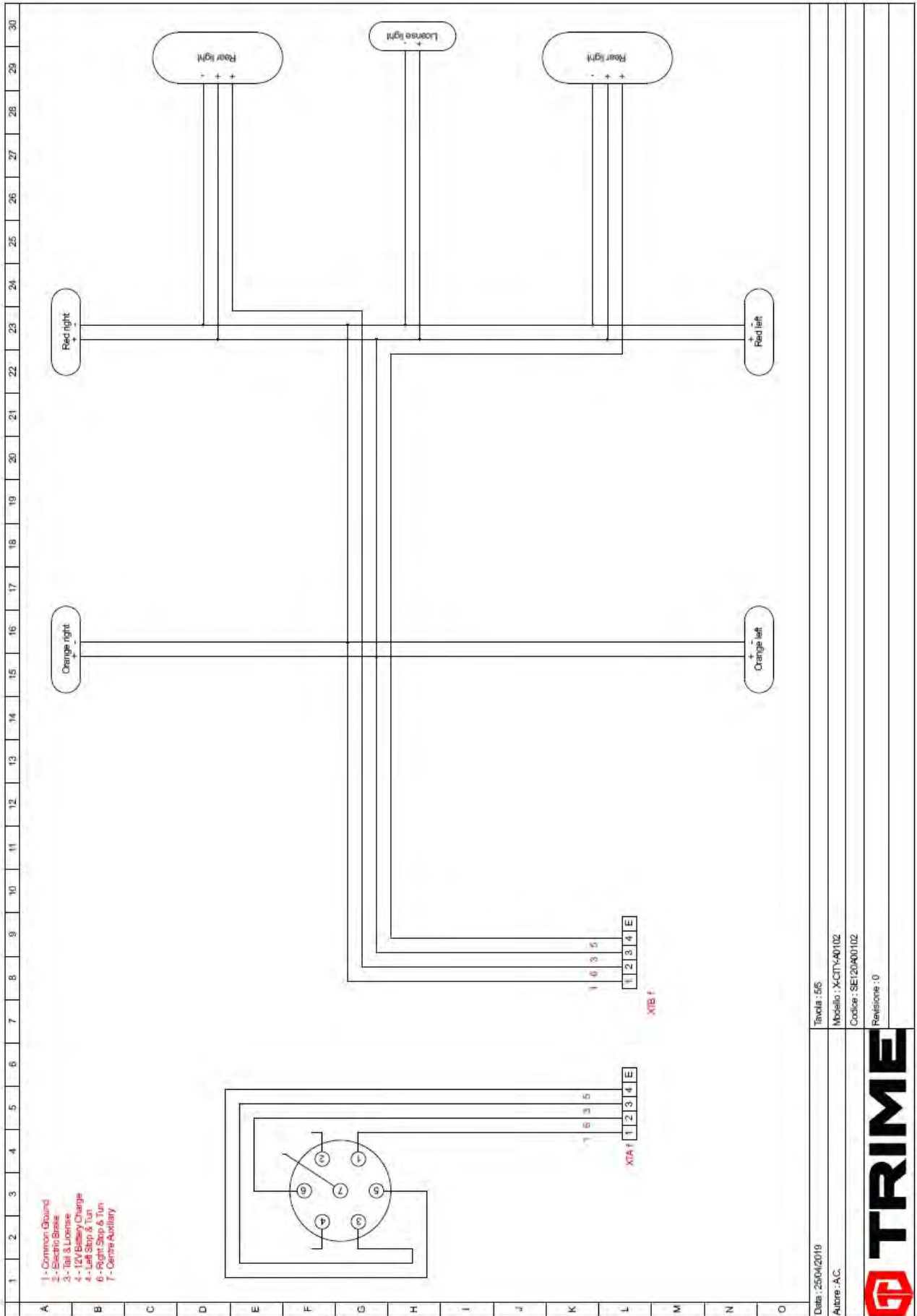

Date : 25/04/2019

Auteur : A.C.

Traccia : 5/5

Modello : X-CITY-401102

Codice : SEI20A00102

Revisione : 0



The warranty period, which starts on the delivery date to the first purchaser, is divided as follows:

- Yanmar Engine - 2 YEARS or 2000 HOURS (whatever as first)
- LED Heads - 3 YEARS
- TRIME LIGHTING TOWER (all the rest) - 1 YEAR

**Only genuine parts should be used to carry out repairs.**

Failure to use only genuine parts may invalidate the manufacturer's warranty.

We reserve the right to request the warranty replaced parts back for analysis.

**All engine warranty issues must be directed to the engine manufacturer, or the manufacturer's approved engine dealer.**

We will not be held responsible if:

- the machine has been used to perform tasks that it has not been designed for;
- the machine has undergone modifications not approved by us;
  - conditions of use have been abnormal;
- normal maintenance, compliant to requirements as set out by the manufacturer, have not been adhered to.

No payment or expenses refund should be pretended from us for normal maintenance or servicing nor any materials used to carry out routine servicing. The warranty is intended to cover diagnosis, repair or replacement of the defective part, and actuating the repair, should a problem arise during the warranty period. These operations will be performed free of charge.

We offer service and warranty training for service and maintenance personnel, if required.

Training can be carried out at a our depot or at a venue of your choice.

Don't hesitate to contact us for any further information.