



An Oshkosh Corporation Company

---

# ***Operation and Safety Manual***

*Original Instructions - keep this manual with the machine at all times.*

***Model***

***530LRT***

***Prior to SN E200000900 and 1200030223***

---

**ANSI**   **AS/NZS**

**3121707**

*December 11, 2019 - Rev H*



## WARNING

Operating, servicing and maintaining this vehicle or equipment can expose you to chemicals including engine exhaust, carbon monoxide, phthalates, and lead, which are known to the State of California to cause cancer and birth defects or other reproductive harm. To minimize exposure, avoid breathing exhaust, do not idle the engine except as necessary, service your vehicle or equipment in a well-ventilated area and wear gloves or wash your hands frequently when servicing. For more information go to [www.P65Warnings.ca.gov](http://www.P65Warnings.ca.gov).

## **FOREWORD**

This manual is a very important tool! Keep it with the machine at all times.

The purpose of this manual is to provide owners, users, operators, lessors, and lessees with the precautions and operating procedures essential for the safe and proper machine operation for its intended purpose.

Due to continuous product improvements, JLG Industries, Inc. reserves the right to make specification changes without prior notification. Contact JLG Industries, Inc. for updated information.

Refer to [www.JLG.com](http://www.JLG.com) for Warranty, Product Registration, and other machine-related documentation.

## **SAFETY ALERT SYMBOLS AND SAFETY SIGNAL WORDS**



This is the Safety Alert Symbol. It is used to alert you to the potential personal injury hazards. Obey all safety messages that follow this symbol to avoid possible injury or death.

### **⚠ DANGER**

INDICATES AN IMMINENTLY HAZARDOUS SITUATION. IF NOT AVOIDED, WILL RESULT IN SERIOUS INJURY OR DEATH. THIS DECAL WILL HAVE A RED BACKGROUND.

### **⚠ WARNING**

INDICATES A POTENTIALLY HAZARDOUS SITUATION. IF NOT AVOIDED, COULD RESULT IN SERIOUS INJURY OR DEATH. THIS DECAL WILL HAVE AN ORANGE BACKGROUND.

### **⚠ CAUTION**

INDICATES A POTENTIALLY HAZARDOUS SITUATION. IF NOT AVOIDED, MAY RESULT IN MINOR OR MODERATE INJURY. IT MAY ALSO ALERT AGAINST UNSAFE PRACTICES. THIS DECAL WILL HAVE A YELLOW BACKGROUND.

### **NOTICE**

INDICATES INFORMATION OR A COMPANY POLICY THAT RELATES DIRECTLY OR INDIRECTLY TO THE SAFETY OF PERSONNEL OR PROTECTION OF PROPERTY.



**⚠ WARNING**

**THIS PRODUCT MUST COMPLY WITH ALL SAFETY RELATED BULLETINS. CONTACT JLG INDUSTRIES, INC. OR THE LOCAL AUTHORIZED JLG REPRESENTATIVE FOR INFORMATION REGARDING SAFETY-RELATED BULLETINS WHICH MAY HAVE BEEN ISSUED FOR THIS PRODUCT.**

**NOTICE**

**JLG INDUSTRIES, INC. SENDS SAFETY RELATED BULLETINS TO THE OWNER OF RECORD OF THIS MACHINE. CONTACT JLG INDUSTRIES, INC. TO ENSURE THAT THE CURRENT OWNER RECORDS ARE UPDATED AND ACCURATE.**

**NOTICE**

**JLG INDUSTRIES, INC. MUST BE NOTIFIED IMMEDIATELY IN ALL INSTANCES WHERE JLG PRODUCTS HAVE BEEN INVOLVED IN AN ACCIDENT INVOLVING BODILY INJURY OR DEATH OR WHEN SUBSTANTIAL DAMAGE HAS OCCURRED TO PERSONAL PROPERTY OR THE JLG PRODUCT.**

**For:**

- Accident Reporting
- Product Safety Publications
- Current Owner Updates
- Questions Regarding Product Safety
- Standards and Regulations Compliance Information
- Questions Regarding Special Product Applications
- Questions Regarding Product Modifications

**Contact:**

Product Safety and Reliability Department  
JLG Industries, Inc.  
13224 Fountainhead Plaza  
Hagerstown, MD 21742

or Your Local JLG Office  
(See addresses on manual rear cover)

**In USA:**

Toll Free: 877-JLG-SAFE (877-554-7233)

**Outside USA:**

Phone: 240-420-2661  
E-mail: ProductSafety@JLG.com

**REVISION LOG**

Original Issue - A ..... August 18, 2015  
Manual Revised - B ..... September 14, 2015  
Manual Revised - C ..... April 20, 2016  
Manual Revised - D ..... July 14, 2016  
Manual Revised - E ..... January 30, 2018  
Manual Revised - F ..... August 20, 2018  
Manual Revised - G ..... December 10, 2018  
Manual Revised - H ..... December 11, 2019

**SECTION - 1 - SAFETY PRECAUTIONS**

1.1 GENERAL..... 1-1

1.2 PRE-OPERATION..... 1-2

    Operator Training and Knowledge ..... 1-2

    Workplace Inspection ..... 1-2

    Machine Inspection ..... 1-3

1.3 OPERATION ..... 1-3

    General ..... 1-3

    Trip and Fall Hazards ..... 1-5

    Electrocution Hazards ..... 1-6

    Tipping Hazards..... 1-7

    Crushing and Collision Hazards ..... 1-9

1.4 TOWING, LIFTING, AND HAULING ..... 1-11

1.5 MAINTENANCE ..... 1-11

    Maintenance Hazards ..... 1-11

    Battery Hazards ..... 1-12

**SECTION - 2 - USER RESPONSIBILITIES, MACHINE PREPARATION, AND INSPECTION**

2.1 PERSONNEL TRAINING..... 2-1

    Operator Training ..... 2-1

    Training Supervision ..... 2-1

    Operator Responsibility ..... 2-1

2.2 PREPARATION, INSPECTION, AND MAINTENANCE ..... 2-2

    Pre-Start Inspection ..... 2-4

    Walk-Around Inspection..... 2-7

Function Check..... 2-10

2.3 OSCILLATING AXLE - LOCKOUT CYLINDER TEST (IF EQUIPPED)..... 2-12

    Left Side Wheel Test ..... 2-12

    Right Side Wheel Test..... 2-13

**SECTION - 3 - MACHINE CONTROLS, INDICATORS, AND OPERATION**

3.1 GENERAL ..... 3-1

3.2 DESCRIPTION ..... 3-1

3.3 OPERATING CHARACTERISTICS AND LIMITATIONS ..... 3-2

    General ..... 3-2

    Placards..... 3-2

3.4 PLATFORM LOADING ..... 3-2

3.5 GROUND CONTROLS AND INDICATORS ..... 3-4

    Ground Control Station ..... 3-6

    Platform Auxiliary Descent (SN E200000676 to ... E200000900) 3-8

    Operation ..... 3-8

3.6 PLATFORM CONTROL STATION..... 3-9

    Platform Controls..... 3-11

3.7 ENGINE OPERATION ..... 3-16

    Starting Procedure..... 3-16

3.8 DUAL FUEL SYSTEM (IF EQUIPPED) ..... 3-17

3.9 OPERATING CHARACTERISTICS ..... 3-18

    Platform Loading ..... 3-18

## TABLE OF CONTENTS

---

Traveling (Driving).....	3-18
Traveling Forward .....	3-18
Traveling in Reverse .....	3-19
Traveling on Grade .....	3-19
Steering.....	3-19
Leveling Jack Operation .....	3-21
Auto Leveling .....	3-21
Manual Level Adjustment (Trim) .....	3-22
Raising and Lowering Platform.....	3-22
Raising .....	3-22
Lowering.....	3-23
Platform Extension .....	3-23
Platform Cable Hook.....	3-23
3.10 PLATFORM RAILS FOLD-DOWN PROCEDURE...	3-24
3.11 PARKING AND STOWING.....	3-27
3.12 TIE DOWN/LIFT LUGS .....	3-27
Tie Down.....	3-27
Lifting.....	3-27
3.13 TOWING.....	3-27

### SECTION - 4 - EMERGENCY PROCEDURES

4.1 GENERAL .....	4-1
4.2 EMERGENCY TOWING PROCEDURES.....	4-1
4.3 EMERGENCY CONTROLS AND LOCATIONS.....	4-2
Emergency Stop Switch.....	4-2
Ground Control Station .....	4-2

4.4 EMERGENCY OPERATION .....	4-2
Use of Ground Controls .....	4-2
Operator Unable to Control Machine .....	4-2
Machine Safety System Override (MSSO) (CE Only) .....	4-3
Platform Caught Overhead .....	4-3
Righting of Tipped Machine.....	4-4
Post-Incident Inspection .....	4-4
Platform Auxiliary Descent (SN E200000676 to .. E200000900) .....	4-4
4.5 INCIDENT NOTIFICATION .....	4-5

### SECTION - 5 - ACCESSORIES

5.1 1/2 AIRLINE .....	5-2
5.2 PLATFORM WORKLIGHTS.....	5-2
5.3 PIPE RACKS .....	5-3
Safety Precautions .....	5-3
Preparation and Inspection.....	5-4
Operation .....	5-4
5.4 WORKSTATION.....	5-5
Safety Precautions .....	5-5
Preparation and Inspection.....	5-5
Operation .....	5-5
5.5 LARGE MATERIAL RACKS .....	5-6
Safety Precautions .....	5-6
Preparation and Inspection.....	5-7
Operation .....	5-7

**SECTION - 6 - GENERAL SPECIFICATIONS AND OPERATOR MAINTENANCE**

- 6.1 INTRODUCTION ..... 6-1
- 6.2 SUPPLEMENTAL INFORMATION ..... 6-1
- 6.3 OPERATING SPECIFICATIONS ..... 6-2
  - Dimensional Data ..... 6-3
  - Capacities..... 6-3
  - Tires ..... 6-3
  - Engine Specifications..... 6-4
  - Critical Stability Weights..... 6-5
  - Lubrication ..... 6-6
- 6.4 OPERATOR MAINTENANCE ..... 6-10
  - Scissor Arm Safety Prop ..... 6-10
  - General Maintenance Tips ..... 6-11
  - Operator Maintenance Components ..... 6-12
  - Fuel Tank ..... 6-13
  - Drive Hub ..... 6-13
  - Scissor Arms - Sliding Wear Pads..... 6-13
  - Oil Change with Filter ..... 6-14
  - Hydraulic Oil Tank..... 6-15
  - Fuel/Water Separator Filter (Diesel) - Kubota 6-15
  - Hydraulic Charge Filter ..... 6-16
  - Fuel Strainer (Diesel) - Kubota ..... 6-16
  - Fuel Filter (Gas) - Kubota..... 6-17
  - Air Filter ..... 6-17
  - Engine Coolant..... 6-18

- 6.5 PROPANE FUEL SYSTEM PRESSURE RELIEF ..... 6-18
- 6.6 PROPANE FUEL SYSTEM LEAK TEST ..... 6-19
- 6.7 TIRES AND WHEELS..... 6-19
  - Tire Damage..... 6-19
  - Tire Replacement..... 6-19
  - Wheel Replacement ..... 6-20
  - Wheel Installation ..... 6-20
- 6.8 DECAL INSTALLATION ..... 6-22

**SECTION - 7 - INSPECTION AND REPAIR LOG**

## **TABLE OF CONTENTS**

---

### **LIST OF FIGURES**

3-1.	Location of Machine Controls .....	3-3	6-10.	Decal Location - Sheet 3 of 4 (CE/AUS/JPN) ....	6-28
3-2.	Ground Control Station .....	3-4	6-11.	Decal Location - Sheet 4 of 4 (CE/AUS/JPN) ....	6-29
3-3.	Ground Control Station (CE Only - Prior to SN E200000675)3-5				
3-4.	Platform Control Station (Prior to SN E200000675) .....	3-9			
3-5.	Platform Control Station (SN E200000676 to E200000900)3-10				
3-6.	Grade and Sideslope.....	3-20			
3-7.	Platform End Rails - Fold Down Sequence .....	3-25			
3-8.	Platform Side Rails - Fold Down Sequence.....	3-26			
3-9.	Lifting and Tie Down Chart (Sheet 1 of 2) .....	3-28			
3-10.	Lifting and Tie Down Chart (Sheet 2 of 2) .....	3-29			
4-1.	Platform Auxiliary Descent Location.....	4-5			
6-1.	Hydraulic Oil Operating Temperature Specifications .....	6-7			
6-2.	Engine Oil Operating Temperature Specifications - Kubota (Dual Fuel Engine).....	6-8			
6-3.	Engine Oil Operating Temperature Specifications - Kubota (Diesel Engine) .....	6-9			
6-4.	Scissor Arm - Safety Prop Assembly .....	6-10			
6-5.	Safety Prop Actuator Rod .....	6-11			
6-6.	Kubota Dual Fuel (WG972-GL-E4) .....	6-14			
6-7.	Kubota Diesel (D1305-E3B and D1305-E4B) ....	6-14			
6-8.	Decal Location - Sheet 1 of 4 (CE/AUS/JPN) ....	6-26			
6-9.	Decal Location - Sheet 2 of 4 (CE/AUS/JPN) ....	6-27			

**LIST OF TABLES**

1-1 Minimum Approach Distances (M.A.D.) .....1-7  
1-2 Beaufort Scale (For Reference Only) .....1-8  
2-1 Inspection and Maintenance Table.....2-3  
2-2 Maximum Cutout Height .....2-10  
2-3 Tilt Cutout Settings (Prior to SN E200000675)...2-11  
2-4 Tilt Cutout Settings (SN E200000676 to  
E200000900) .....2-11  
5-1 Available Accessories .....5-1  
6-1 Kubota Diesel (D1305-E4B) .....6-4  
6-2 Kubota Diesel (D1305-E3B) .....6-4  
6-3 Kubota Dual Fuel (WG972-GL-E4) .....6-5  
6-4 Lubrication Specifications .....6-6  
6-5 Wheel Torque Chart .....6-21  
6-6 Decal Location Legend - ANSI, ANSI Export ...6-24  
6-7 Decal Legend - CE/AUS/JPN.....6-30  
7-1 Inspection and Repair Log .....7-1

## **TABLE OF CONTENTS**

---



## **SECTION 1. SAFETY PRECAUTIONS**

### **1.1 GENERAL**

This section outlines the necessary precautions for proper and safe machine usage and maintenance. In order to promote proper machine usage, it is mandatory that a daily routine is established based on the content of this manual. A maintenance program, using the information provided in this manual and the Service and Maintenance Manual, must also be established by a qualified person and must be followed to ensure that the machine is safe to operate.

The owner/user/operator/lessor/lessee of the machine must not accept operating responsibility until this manual has been read, training is accomplished, and operation of the machine has been completed under the supervision of an experienced and qualified operator.

These sections contain the responsibilities of the owner, user, operator, lessor, and lessee concerning safety, training, inspection, maintenance, application, and operation. If there are any questions with regard to safety, training, inspection, maintenance, application, and operation, please contact JLG Industries, Inc. ("JLG").

### **WARNING**

**FAILURE TO COMPLY WITH THE SAFETY PRECAUTIONS LISTED IN THIS MANUAL COULD RESULT IN MACHINE DAMAGE, PROPERTY DAMAGE, PERSONAL INJURY OR DEATH.**

### 1.2 PRE-OPERATION

#### Operator Training and Knowledge

- The Operation and Safety Manual must be read and understood in its entirety before operating the machine. For clarification, questions, or additional information regarding any portions of this manual, contact JLG Industries, Inc.

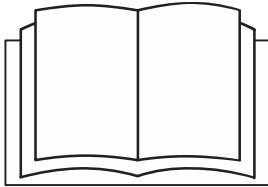

- An operator must not accept operating responsibilities until adequate training has been given by competent and authorized persons.
- Allow only those authorized and qualified personnel to operate the machine who have demonstrated that they understand the safe and proper operation and maintenance of the unit.
- Read, understand, and obey all DANGERS, WARNINGS, CAUTIONS, and operating instructions on the machine and in this manual.

- Ensure that the machine is to be used in a manner which is within the scope of its intended application as determined by JLG.
- All operating personnel must be familiar with the emergency controls and emergency operation of the machine as specified in this manual.
- Read, understand, and obey all applicable employer, local, and governmental regulations as they pertain to your utilization and application of the machine.

#### Workplace Inspection

- Precautions to avoid all hazards in the work area must be taken by the user before and during operation of the machine.
- Do not operate or raise the platform from a position on trucks, trailers, railway cars, floating vessels, scaffolds or other equipment unless the application is approved in writing by JLG.
- Before operation, check work area for overhead hazards such as electric lines, bridge cranes, and other potential overhead obstructions.
- Check floor surfaces for holes, bumps, drop-offs, obstructions, debris, concealed holes, and other potential hazards.

- Check the work area for hazardous locations. Do not operate the machine in hazardous environments unless approved for that purpose by JLG.
- Ensure that the ground conditions are adequate to support the maximum tire load indicated on the tire load decals located on the chassis adjacent to each wheel.

### **Machine Inspection**

- Do not operate this machine until the inspections and functional checks have been performed as specified in Section 2 of this manual.
- Do not operate this machine until it has been serviced and maintained according to the maintenance and inspection requirements as specified in the machine's Service and Maintenance Manual.
- Ensure all safety devices are operating properly. Modification of these devices is a safety violation.

### **WARNING**

**MODIFICATION OR ALTERATION OF AN AERIAL WORK PLATFORM SHALL BE MADE ONLY WITH PRIOR WRITTEN PERMISSION FROM THE MANUFACTURER.**

- Do not operate any machine on which the safety or instruction placards or decals are missing or illegible.
- Check the machine for modifications to original components. Ensure that any modifications have been approved by JLG.
- Avoid accumulation of debris on platform deck. Keep mud, oil, grease, and other slippery substances from footwear and platform deck.

## **1.3 OPERATION**

### **General**

- Machine operation requires your full attention. Bring the machine to a full stop before using any device, i.e. cell phones, two-way radios, etc. that will distract your attention from safely operating the machine.
- Do not use the machine for any purpose other than positioning personnel, their tools, and equipment.
- Before operation, the user must be familiar with the machine capabilities and operating characteristics of all functions.
- Never operate a malfunctioning machine. If a malfunction occurs, shut down the machine. Remove the unit from service and notify the proper authorities.

## **SECTION 1 - SAFETY PRECAUTIONS**

---

- Do not remove, modify, or disable any safety devices.
- Never slam a control switch or lever through neutral to an opposite direction. Always return switch to neutral and stop before moving the switch to the next function. Operate controls with slow and even pressure.
- Do not allow personnel to tamper with or operate the machine from the ground with personnel in the platform, except in an emergency.
- Do not carry materials directly on platform railing unless approved by JLG.
- When two or more persons are in the platform, the operator shall be responsible for all machine operations.
- Always ensure that power tools are properly stowed and never left hanging by their cord from the platform work area.
- Do not assist a stuck or disabled machine by pushing or pulling except by pulling at the chassis tie-down lugs.
- Fully lower platform and shut off all power before leaving machine.
- Remove all rings, watches, and jewelry when operating machine. Do not wear loose fitting clothing or long hair unrestrained which may become caught or entangled in equipment.
- Persons under the influence of drugs or alcohol or who are subject to seizures, dizziness or loss of physical control must not operate this machine.

### Trip and Fall Hazards

- Prior to operation, ensure all gates and rails are fastened and secured in their proper position.

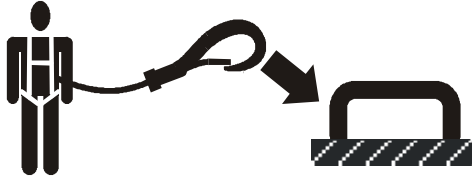

- JLG Industries, Inc. recommends that all persons in the platform wear a full body harness with a lanyard attached to an authorized lanyard anchorage point while operating this machine. For further information regarding fall protection requirements on JLG products, contact JLG Industries, Inc.
- Identify the designated lanyard anchorage point(s) at the platform and securely attach the lanyard. Attach only one (1) lanyard per lanyard anchorage point.
- Enter and exit only through gate area. Use extreme caution when entering or leaving platform. Ensure that the platform assembly is fully lowered. Face the machine when entering or leaving the platform. Always maintain “three point contact” with the machine, using two hands and one foot or two feet and one hand at all times during entry and exit.

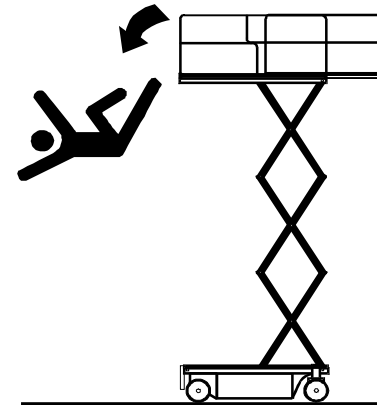

- Keep both feet firmly positioned on the platform floor at all times. Never position ladders, boxes, steps, planks, or similar items on unit to provide additional reach for any purpose.
- Never use the scissor arm assembly to gain access to or leave the platform.
- Keep oil, mud, and slippery substances cleaned from footwear and the platform floor.

## SECTION 1 - SAFETY PRECAUTIONS

---

### Electrocution Hazards

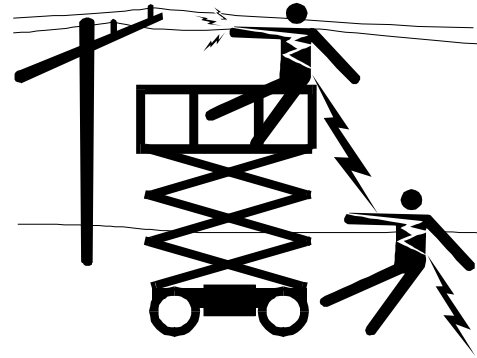
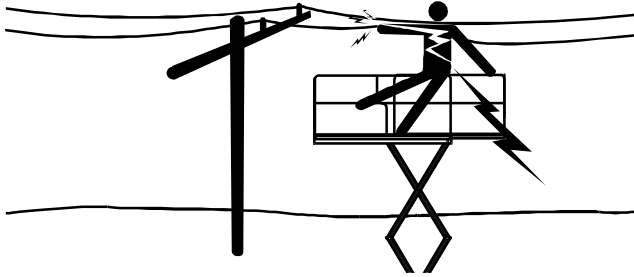

- This machine is not insulated and does not provide protection from contact or proximity to electrical current.
  - Maintain distance from electrical lines, apparatus, or any energized (exposed or insulated) parts according to the Minimum Approach Distance (MAD) as shown in Table 1-1.
  - Allow for machine movement and electrical line swaying.
  - Maintain a clearance of at least 10 ft (3 m) between any part of the machine and its occupants, their tools, and their equipment from any electrical line or apparatus carrying up to 50,000 volts. One foot additional clearance is required for every additional 30,000 volts or less.
- The minimum approach distance may be reduced if insulating barriers are installed to prevent contact, and the barriers are rated for the voltage of the line being guarded. These barriers shall not be part of (or attached to) the machine. The minimum approach distance shall be reduced to a distance within the designed working dimensions of the insulating barrier. This determination shall be made by a qualified person in accordance with the employer, local, or governmental requirements for work practices near energized equipment.



**DO NOT MANEUVER MACHINE OR PERSONNEL INSIDE PROHIBITED ZONE (MAD). ASSUME ALL ELECTRICAL PARTS AND WIRING ARE ENERGIZED UNLESS KNOWN OTHERWISE.**

**Table 1-1. Minimum Approach Distances (M.A.D.)**

<b>VOLTAGE RANGE (Phase to Phase)</b>	<b>MINIMUM APPROACH DISTANCE in Feet (Meters)</b>
0 to 50 KV	10 (3)
Over 50KV to 200 KV	15 (5)
Over 200 KV to 350 KV	20 (6)
Over 350 KV to 500 KV	25 (8)
Over 500 KV to 750 KV	35 (11)
Over 750 KV to 1000 KV	45 (14)
<b>NOTE: This requirement shall apply except where employer, local or governmental regulations are more stringent.</b>	

**Tipping Hazards**

- Ensure that the ground conditions are adequate to support the maximum tire load indicated on the tire load decals located on the chassis adjacent to each wheel. Do not travel on unsupported surfaces.
- The user must be familiar with the driving surface before driving. Do not exceed the allowable sideslope and grade while driving.
- Do not elevate platform or drive with platform elevated while on or near a sloping, uneven, or soft surface. Ensure machine is positioned on a firm, level and smooth surface before elevating platform or driving with the platform in the elevated position.
- Before driving on floors, bridges, trucks, and other surfaces, check allowable capacity of the surfaces.
- Never exceed the maximum work load as specified on the platform. Keep all loads within the confines of the platform, unless authorized by JLG.
- Keep the chassis of the machine a minimum of 2 ft. (0.6m) from holes, bumps, drop-offs, obstructions, debris, concealed holes, and other potential hazards at the ground level.
- Do not operate the machine when wind conditions exceed specifications shown in Section 6.3 or as shown on the capacity placard on the platform billboard.

## SECTION 1 - SAFETY PRECAUTIONS

---

### WARNING

DO NOT OPERATE THE MACHINE WHEN WIND CONDITIONS EXCEED SPECIFICATIONS SHOWN IN SECTION 6.3 OR AS SHOWN ON THE CAPACITY PLACARD ON THE PLATFORM BILLBOARD.

**Table 1-2. Beaufort Scale (For Reference Only)**

BEAUFORT NUMBER	WIND SPEED		DESCRIPTION	LAND CONDITIONS
	mph	m/s		
0	0	0-0.2	Calm	Calm. Smoke rises vertically.
1	1-3	0.3-1.5	Light air	Wind motion visible in smoke.
2	4-7	1.6-3.3	Light breeze	Wind felt on exposed skin. Leaves rustle.
3	8-12	3.4-5.4	Gentle breeze	Leaves and smaller twigs in constant motion.
4	13-18	5.5-7.9	Moderate breeze	Dust and loose paper raised. Small branches begin to move.
5	19-24	8.0-10.7	Fresh breeze	Smaller trees sway.
6	25-31	10.8-13.8	Strong breeze	Large branches in motion. Flags waving near horizontal. Umbrella use becomes difficult.
7	32-38	13.9-17.1	Near Gale/Moderate Gale	Whole trees in motion. Effort needed to walk against the wind.
8	39-46	17.2-20.7	Fresh Gale	Twigs broken from trees. Cars veer on road.
9	47-54	20.8-24.4	Strong Gale	Light structure damage.



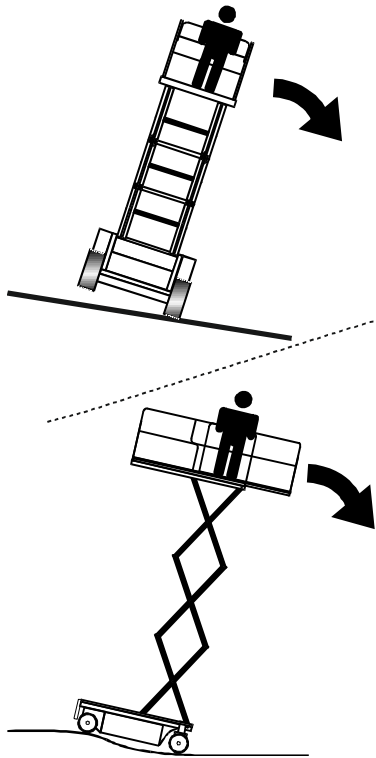

- Never attempt to use the machine as a crane. Do not tie-off machine to any adjacent structure. Never attach wire, cable, or any similar items to platform.
- Do not cover the platform sides or carry large surface-area items in the platform when operating outdoors. The addition of such items increases the exposed wind area of the machine.
- Do not increase the platform size with unauthorized deck extensions or attachments.
- If the scissor arm assembly or platform is caught so that one or more wheels are off the ground, all persons must be removed before attempting to free the machine. Use cranes, forklift trucks, or other appropriate equipment to stabilize machine and remove personnel.

### **Crushing and Collision Hazards**

- Approved head gear must be worn by all operating and ground personnel.
- Keep hands and limbs out of the scissor arm assembly during operation and when elevated without safety prop engaged.
- Watch for obstructions around machine and overhead when driving. Check clearances above, on sides, and bottom of platform when lifting or lowering platform.

## SECTION 1 - SAFETY PRECAUTIONS

---

- During operation, keep all body parts inside platform railing.

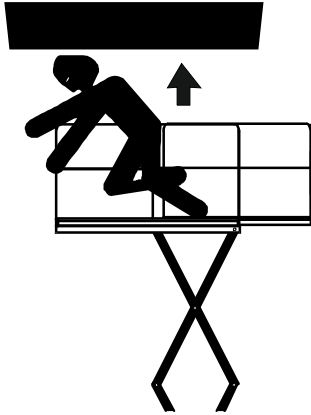

- Always post a lookout when driving in areas where vision is obstructed.
- Keep non-operating personnel at least 6 ft. (1.8m) away from machine during all operations.
- Under all travel conditions, the operator must limit travel speed according to conditions of ground surface, congestion, visibility, slope, location of personnel, and other factors.

- Be aware of stopping distances in all drive speeds. When driving in high speed, switch to low speed before stopping. Travel grades in low speed only.
- Do not use high speed drive in restricted or close quarters or when driving in reverse.
- Exercise extreme caution at all times to prevent obstacles from striking or interfering with operating controls and persons in the platform.
- Ensure that operators of other overhead and floor level machines are aware of the aerial work platform's presence. Disconnect power to overhead cranes. Barricade floor area if necessary.
- Do not operate over ground personnel. Warn personnel not to work, stand, or walk under a raised platform. Position barricades on floor as necessary.

## 1.4 TOWING, LIFTING, AND HAULING

- Never allow personnel in platform while towing, lifting, or hauling.
- This machine should not be towed, except in the event of emergency, malfunction, power failure, or loading/unloading. Refer to emergency towing procedures.
- Ensure platform is fully retracted and completely empty of tools prior to towing, lifting or hauling.
- When lifting machine with a forklift, position forks only at designated areas of the machine. Lift with a forklift of adequate capacity.
- Refer to Section 3 for lifting information.

## 1.5 MAINTENANCE

This sub-section contains general safety precautions which must be observed during maintenance of this machine. Additional precautions to be observed during machine maintenance are inserted at the appropriate points in this manual and in the Service and Maintenance Manual. It is of utmost importance that maintenance personnel pay strict attention to these precautions to avoid possible injury to personnel or damage to the machine or property. A maintenance program

must be established by a qualified person and must be followed to ensure that the machine is safe.

### Maintenance Hazards

- Shut off power to all controls and ensure that all moving parts are secured from inadvertent motion prior to performing any adjustments or repairs.
- Never work under an elevated platform until it has been fully lowered to the full down position, if possible, or otherwise supported and restrained from movement with appropriate safety props, blocking, or overhead supports.
- DO NOT attempt to repair or tighten any hydraulic hoses or fittings while the machine is powered on or when the hydraulic system is under pressure.
- Always relieve hydraulic pressure from all hydraulic circuits before loosening or removing hydraulic components.
- DO NOT use your hand to check for leaks. Use a piece of cardboard or paper to search for leaks. Wear gloves to help protect hands from spraying fluid.
- Ensure replacement parts or components are identical or equivalent to original parts or components.



## SECTION 1 - SAFETY PRECAUTIONS

---

- Never attempt to move heavy parts without the aid of a mechanical device. Do not allow heavy objects to rest in an unstable position. Ensure adequate support is provided when raising components of the machine.
- Use only approved non-flammable cleaning solvents.
- Do not replace items critical to stability, such as batteries or solid , with items of different weight or specification. Do not modify unit in any way to affect stability.
- Reference the Service and Maintenance Manual for the weights of critical stability items.

### **WARNING**

**MODIFICATION OR ALTERATION OF AN AERIAL WORK PLATFORM SHALL BE MADE ONLY WITH PRIOR WRITTEN PERMISSION FROM THE MANUFACTURER.**

### **Battery Hazards**

- Always disconnect batteries when servicing electrical components or when performing welding on the machine.
- Do not allow smoking, open flame, or sparks near battery during charging or servicing.
- Do not contact tools or other metal objects across the battery terminals.
- Always wear hand, eye, and face protection when servicing batteries. Ensure that battery acid does not come in contact with skin or clothing.

### **CAUTION**

**BATTERY FLUID IS HIGHLY CORROSIVE. AVOID CONTACT WITH SKIN AND CLOTHING AT ALL TIMES. IMMEDIATELY RINSE ANY CONTACTED AREA WITH CLEAN WATER AND SEEK MEDICAL ATTENTION.**

- Charge batteries only in a well ventilated area.
- Avoid overfilling the battery fluid level. Add distilled water to batteries only after the batteries are fully charged.

## **SECTION 2. USER RESPONSIBILITIES, MACHINE PREPARATION, AND INSPECTION**

### **2.1 PERSONNEL TRAINING**

The aerial platform is a personnel handling device, so it is necessary that it be operated and maintained only by trained personnel.

Persons under the influence of drugs or alcohol or who are subject to seizures, dizziness or loss of physical control must not operate this machine.

#### **Operator Training**

Operator training must cover:

1. Use and limitations of the controls in the platform and at the ground, emergency controls and safety systems.
2. Control labels, instructions, and warnings on the machine.
3. Rules of the employer and government regulations.
4. Use of approved fall protection device.
5. Enough knowledge of the mechanical operation of the machine to recognize a malfunction or potential malfunction.

6. The safest means to operate the machine where overhead obstructions, other moving equipment, and obstacles, depressions, holes, dropoffs.
7. Means to avoid the hazards of unprotected electrical conductors.
8. Specific job requirements or machine application.

#### **Training Supervision**

Training must be done under the supervision of a qualified person in an open area free of obstructions until the trainee has developed the ability to safely control and operate the machine.

#### **Operator Responsibility**

The operator must be instructed that they have the responsibility and authority to shut down the machine in case of a malfunction or other unsafe condition of either the machine or the job site.

## **2.2 PREPARATION, INSPECTION, AND MAINTENANCE**

The following table covers the machine inspections and maintenance recommended by JLG Industries, Inc. Consult local regulations for further requirements for aerial work platforms. The frequency of inspections and maintenance must be increased as necessary when the machine is used in a harsh or hostile environment, if the machine is used with increased frequency, or if the machine is used in a severe manner.

**SECTION 2 - USER RESPONSIBILITIES, MACHINE PREPARATION, AND INSPECTION**

**Table 2-1. Inspection and Maintenance Table**

<b>Type</b>	<b>Frequency</b>	<b>Primary Responsibility</b>	<b>Service Qualification</b>	<b>Reference</b>
Pre-Start Inspection	Before using each day; or whenever there's an Operator change.	User or Operator	User or Operator	Operator and Safety Manual
Pre-Delivery Inspection (See Note)	Before each sale, lease, or rental delivery.	Owner, Dealer, or User	Qualified JLG Mechanic	Service and Maintenance Manual and applicable JLG inspection form
Frequent Inspection	In service for 3 months or 150 hours, whichever comes first; or Out of service for a period of more than 3 months; or Purchased used.	Owner, Dealer, or User	Qualified JLG Mechanic	Service and Maintenance Manual and applicable JLG inspection form
Annual Machine Inspection (See Note)	Annually, no later than 13 months from the date of prior inspection.	Owner, Dealer, or User	Factory-Trained Service Technician (Recommended)	Service and Maintenance Manual and applicable JLG inspection form
Preventative Maintenance	At intervals as specified in the Service and Maintenance Manual.	Owner, Dealer, or User	Qualified JLG Mechanic	Service and Maintenance Manual

**NOTE:** Inspection forms are available from JLG. Use the Service and Maintenance Manual to perform inspections.

**NOTICE**

**JLG INDUSTRIES, INC. RECOGNIZES A FACTORY-TRAINED SERVICE TECHNICIAN AS A PERSON WHO HAS SUCCESSFULLY COMPLETED THE JLG SERVICE TRAINING SCHOOL FOR THE SPECIFIC JLG PRODUCT MODEL.**

## SECTION 2 - USER RESPONSIBILITIES, MACHINE PREPARATION, AND INSPECTION

### Pre-Start Inspection

The Pre-Start Inspection should include each of the following:

- 1. Cleanliness** – Check all surfaces for leakage (oil, fuel, or battery fluid) or foreign objects. Report any leakage to the proper maintenance personnel.
- 2. Structure** – Inspect the machine structure for dents, damage, weld or parent metal cracks or other discrepancies.

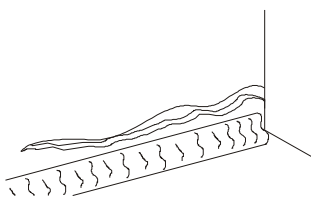

Parent Metal Crack

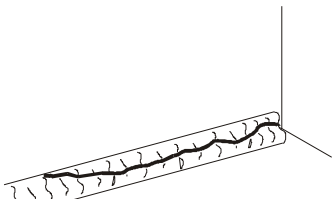

Weld Crack

- 3. Decals and Placards** – Check all for cleanliness and legibility. Make sure none of the decals and placards are missing (refer to the Decal Installation in Section 6). Make sure all illegible decals and placards are cleaned or replaced.
- 4. Operation and Safety Manuals** – Make sure a copy of the Operation and Safety Manual, AEM Safety Manual

(ANSI markets only), and ANSI Manual of Responsibilities (ANSI markets only) is enclosed in the weather resistant storage container.

- 5. Walk-Around Inspection** – Perform as instructed.
- 6. Battery** – Charge as required.
- 7. Fuel** (Combustion Engine Powered Machines) – Add the proper fuel as necessary.
- 8. Hydraulic Oil** – Check the hydraulic oil level. Ensure hydraulic oil is added as required.
- 9. Function Check** – Once the “Walk-Around” Inspection is complete, perform a functional check of all systems in an area free of overhead and ground level obstructions. See “Function Check” on page 2-10. for more specific instructions.
- 10. Accessories/Attachments** - Refer to the Accessories section in this manual or accessory installed upon the machine for specific inspection, operation, and maintenance instructions.

### **⚠ WARNING**

**IF THE MACHINE DOES NOT OPERATE PROPERLY, TURN OFF THE MACHINE IMMEDIATELY! REPORT THE PROBLEM TO THE PROPER MAINTENANCE PERSONNEL. DO NOT OPERATE THE MACHINE UNTIL IT IS DECLARED SAFE FOR OPERATION.**



## SECTION 2 - USER RESPONSIBILITIES, MACHINE PREPARATION, AND INSPECTION

- 11. Platform Gate** – Keep gate and surrounding area clean and unobstructed. Check that gate latches properly and is not bent or damaged. During operation keep gate closed.

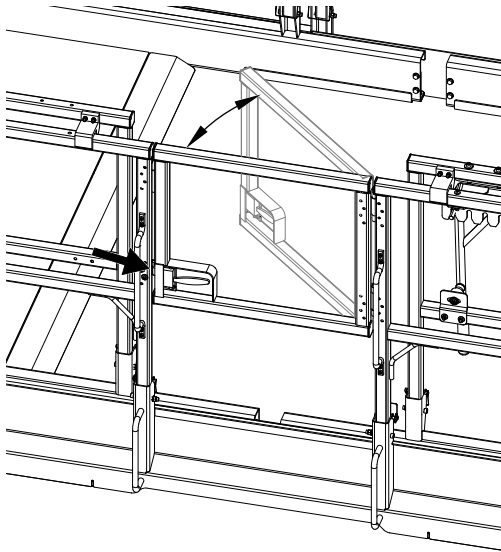

**Self-Closing Swing Gate**

- 12. Lanyard Anchorage Points** – JLG Industries, Inc. recommends personnel in the platform wear a full body harness with a lanyard attached to an authorized lanyard anchorage points (1).

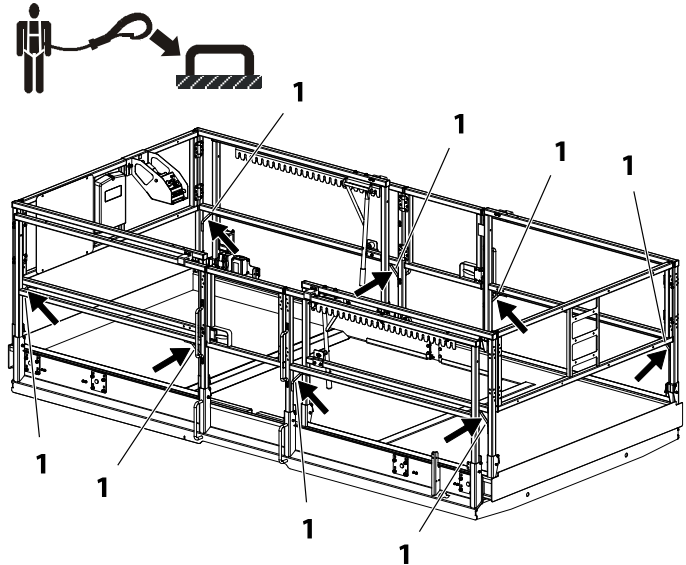

**Standard Lanyard Attach Points**

## SECTION 2 - USER RESPONSIBILITIES, MACHINE PREPARATION, AND INSPECTION

---

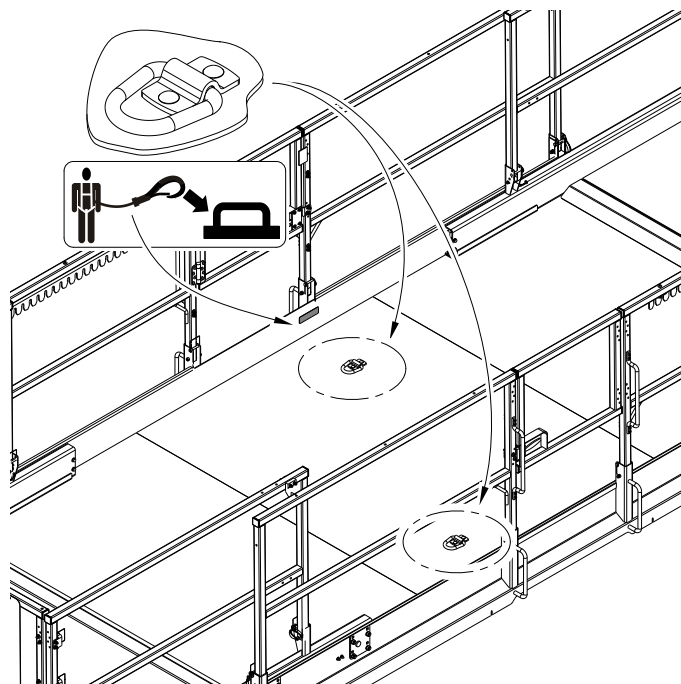

**Optional Lanyard Attach Points (If Equipped)**

Walk-Around Inspection

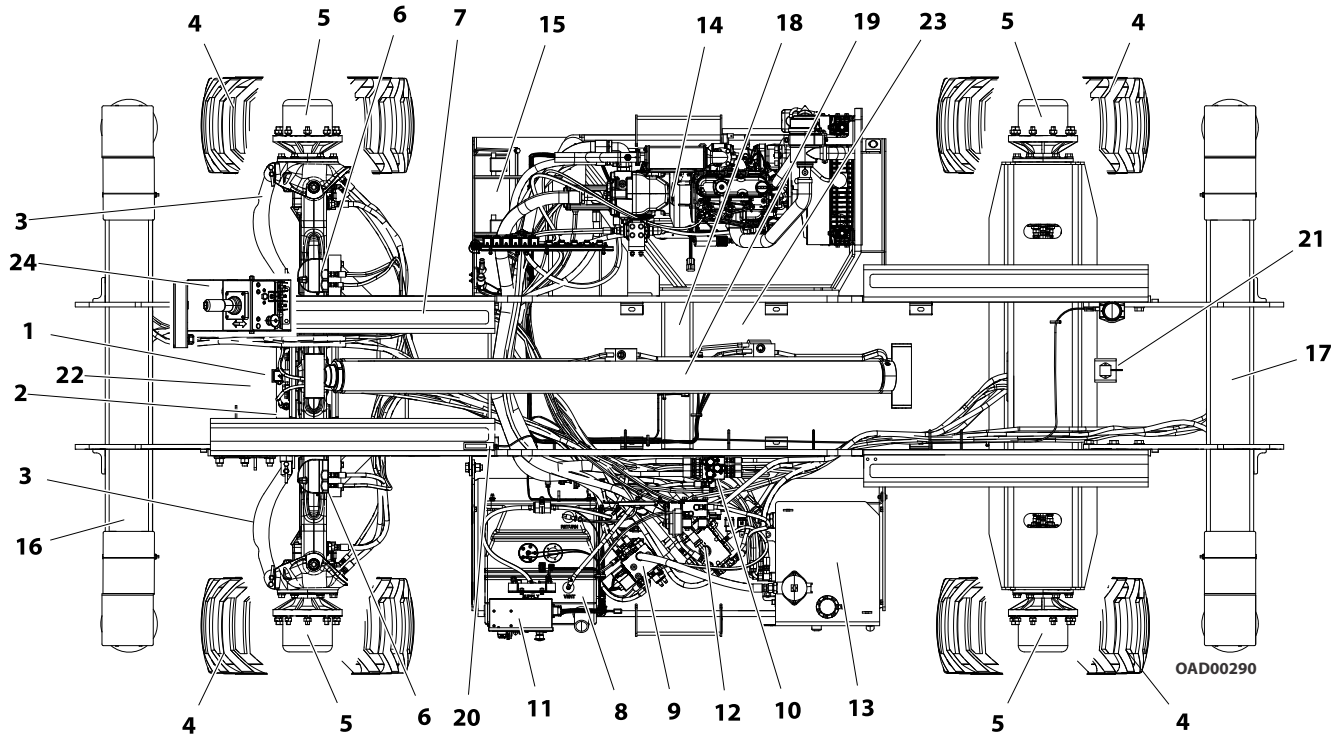

## SECTION 2 - USER RESPONSIBILITIES, MACHINE PREPARATION, AND INSPECTION

---

Begin the Walk-Around Inspection at Item 1, as noted on the preceding diagram. Continue to the right (counterclockwise viewed from top) checking each item in sequence for the conditions listed in the Walk-Around Inspection checklist.

### **WARNING**

**TO AVOID POSSIBLE INJURY, BE SURE MACHINE POWER IS "OFF" DURING WALK-AROUND INSPECTION.**

### **NOTICE**

**DO NOT OVERLOOK VISUAL INSPECTION OF CHASSIS UNDERSIDE. CHECKING THIS AREA OFTEN RESULTS IN DISCOVERY OF CONDITIONS WHICH COULD CAUSE EXTENSIVE MACHINE DAMAGE.**

**INSPECTION NOTE:** *On each item, make sure there are no loose or missing parts, that they are securely fastened, and that no visible damage exists in addition to any other criteria mentioned.*

**NOTE:** *All wheel lugs are to be torqued at 170 ft.lb. (240 Nm).*

- 1. Oscillating Axle Tilt Sensor** – No unsupported wires; no damaged or broken wires - See Inspection Note.
- 2. Steer Cylinder** – See Inspection Note.
- 3. Spindle, Tie Rod and Steer Linkage** - See Inspection Note.
- 4. Wheels and Tires** – Properly secured, no missing lug nuts (refer to Section 6.7). Inspect wheels for damage and corrosion.
- 5. Wheel Drive Hub** – See Inspection Note.
- 6. Fixed Axle or Oscillating Axle, Oscillation Cylinders** – See Inspection Note.
- 7. Scissor Arms, Centering Link and Sliding Wear Pads** – See Inspection Note.
- 8. Fuel Tank** – See Inspection Note.
- 9. Main Control Valve** – No unsupported wires or hoses; no damaged or broken wires.
- 10. Leveling Jack Valve** – No unsupported wires or hoses; no damaged or broken wires.
- 11. Ground Controls** – Placard secure and legible, control switches return to neutral position, emergency stop switch functions properly. Control markings legible.

## SECTION 2 - USER RESPONSIBILITIES, MACHINE PREPARATION, AND INSPECTION

---

12. **Drive Valve** – No unsupported wires or hoses; no damaged or broken wires.
13. **Hydraulic Reservoir** – Recommended hydraulic fluid level on level indicator on tank. Breather cap secure and working.
14. **Engine and Hydraulic Pump Assembly** – See Inspection Note.
15. **Battery Cables/Routing Installation** – See Inspection Note.
16. **Front Leveling Jack Assembly** – See Inspection Note.
17. **Rear Leveling Jack Assembly** – See Inspection Note.
18. **Rotary Angle (Elevation) Sensor** (located on lower arm attach link pin) – See Inspection Note.
19. **Lift Cylinder** – See Inspection Note.
20. **Proximity (Elevation) Sensor (Prior to SN E20000675 and 1200027648 through 1200027657)** – See Inspection Note.
21. **Arm Stack Tilt Sensor (Location Prior to SN E20000675 and 1200027648 through 1200027657)** – See Inspection Note.
22. **Arm Stack Tilt Sensor (Location from SN E20000676 to E20000900 and 1200030223)** – See Inspection Note.
23. **Safety Prop** (On Scissor Arms) (Not Shown) – See Inspection Note.
24. **Platform Control Console** (On Platform Rail) – Placard secure and legible, control lever and switches return to neutral, all switch guards are in place, trigger switch and emergency stop switch function properly, Operation & Safety manual in storage box.
25. **Platform/Handrail Installation** (Not Shown) – See Inspection Note.

## SECTION 2 - USER RESPONSIBILITIES, MACHINE PREPARATION, AND INSPECTION

### Function Check

Perform the Function Check as follows:

1. From the Ground Control Panel with no load in the platform:
  - a. Check that all guards protecting switches are in place.
  - b. Operate all functions. See “Ground Controls and Indicators” on page 3-4.
  - c. Ensure that all machine functions are disabled when the Emergency Stop Button is activated.
  - d. Check that auxiliary descent, lift down operates with engine off and power on.
  - e. Locate yellow auxiliary descent push-button at the front right of machine. Ensure the platform lowers when button is pushed (engine off and power on).
2. From the Platform Control Console:
  - a. Ensure that the control console is firmly secured in the proper location.
  - b. Check that all guards protecting switches are in place.

- c. Operate all functions and check all limiting and cut-out switches. Refer to Table 2-2, Table 2-3, and Table 2-4 for cutouts and limits.

**Table 2-2. Maximum Cutout Height**

Model	High Drive Cutout
530LRT	14 ft (4.26 m)

- d. Ensure that all machine functions are disabled when the Emergency Stop Button is activated.
  - e. Check that auxiliary descent, lift down operates with engine off and power on.
3. With the platform in the transport (stowed) position:
    - a. Drive the machine on a grade, not to exceed the rated gradeability, and stop to ensure the brakes hold.
    - b. Ensure the platform tilt indicator light is illuminated.

**SECTION 2 - USER RESPONSIBILITIES, MACHINE PREPARATION, AND INSPECTION**

**Table 2-3. Tilt Cutout Settings (Prior to SN E20000675)**

Market	Leveling Jacks Set		Leveling Jacks NOT Set		Drive is prevented when elevated beyond the following heights:	Lift Up is prevented when elevated beyond the following heights without leveling jacks set:
	Front to Back	Side to Side	Front to Back	Side to Side		
ANSI,ANSI Exp.	1.5° to 53 ft (16m)	1.5° to 53 ft (16m)	5° to 32 ft (9.75 m)	4° to 32 ft (9.75 m)	32 ft	32 ft
CSA	1.5° to 53 ft (16m)	1.5° to 53 ft (16m)	3° to 32 ft (9.75 m)	3° to 32 ft (9.75 m)	32 ft	32 ft
CE, AUS	1.5° to 53 ft (16m)	1.5° to 53 ft (16m)	5° to 32 ft (9.75 m) 1.3° to 45 ft (13.7 m)	3° to 32 ft (9.75 m) 1.3° to 45 ft (13.7 m)	32 ft	45 ft

**NOTE:** These tilt cutout settings also apply to SN 1200027648 through 1200027657.

**Table 2-4. Tilt Cutout Settings (SN E20000676 to E20000900)**

Market	Leveling Jacks Set		Leveling Jacks NOT Set		Drive is prevented when elevated beyond the following heights:	Lift Up is prevented when elevated beyond the following heights without leveling jacks set:
	Front to Back	Side to Side	Front to Back	Side to Side		
ANSI,ANSI Exp., CE, AUS, Korea	1.5° to 53 ft (16m)	1.5° to 53 ft (16m)	5° to 32 ft (9.75 m) 1.3° to 45 ft (13.7 m)	3° to 32 ft (9.75 m) 1.3° to 45 ft (13.7 m)	32 ft	45 ft
CSA	1.5° to 53 ft (16m)	1.5° to 53 ft (16m)	3° to 32 ft (9.75 m)	3° to 32 ft (9.75 m)	32 ft	32 ft

**NOTE:** These tilt cutout settings also apply to SN 1200030223.

### 2.3 OSCILLATING AXLE - LOCKOUT CYLINDER TEST (IF EQUIPPED)

#### NOTICE

**LOCKOUT CYLINDER SYSTEM TEST MUST BE PERFORMED QUARTERLY, ANY TIME A SYSTEM COMPONENT IS REPLACED, OR WHEN IMPROPER SYSTEM OPERATION IS SUSPECTED.**

**NOTE:** *Ensure platform is fully lowered prior to beginning lockout cylinder test, and that the surface used to approach the ramp is flat and level.*

#### Left Side Wheel Test

1. Place a 4 in (10.16 cm) high block with ascension ramp in front of left wheel of the oscillating axle.
2. From platform control station, select LOW drive speed.
3. Set the DRIVE control switch into position and carefully drive the machine up ascension ramp until left oscillating axle wheel is on top of block.
4. Verify the axle oscillates to maintain contact with the ground/ramp. (All four wheels on the ground).
5. Raise machine platform above stowed position approximately 14 ft (4.26 m) on the 530LRT.

6. Carefully drive the machine back off the block and ramp.
7. Have an assistant check to see that the left oscillating axle wheel that was on the block is in position on the ground. The axle should oscillate so that all four wheels maintain contact with the ground.
8. In the current position (platform raised and all four on flat and level surface), carefully drive machine up the ramp block again.
9. Have an assistant check to verify that the axle did not oscillate and remained locked (one wheel is off of the ground).
10. Carefully drive the machine back off the block and ramp.
11. Lower the machine platform; the lockout cylinder should then release and allow the axle to oscillate. It may be necessary to activate DRIVE to release cylinders.
12. If the lockout cylinders do not function properly, have qualified personnel correct the malfunction prior to any further operation.



### **Right Side Wheel Test**

- 1.** Place a 4 in (10.16 cm) high block with ascension ramp in front of right wheel of the oscillating axle.
- 2.** From platform control station, select LOW drive speed.
- 3.** Set the DRIVE control switch into position and carefully drive the machine up ascension ramp until right oscillating axle wheel is on top of block.
- 4.** Verify the axle oscillates to maintain contact with the ground/ramp. (All four wheels on the ground).
- 5.** Raise machine platform above stowed position approximately 14 ft (4.26 m) on the 530LRT.
- 6.** Carefully drive the machine back off the block and ramp.
- 7.** Have an assistant check to see that the right oscillating axle wheel that was on the block is in position on the ground. The axle should oscillate so that all four wheels maintain contact with the ground.
- 8.** In the current position (platform raised and all four on flat and level surface), carefully drive machine up the ramp block again.
- 9.** Have an assistant check to verify that the axle did not oscillate and remained locked (one wheel is off of the ground).
- 10.** Carefully drive the machine back off the block and ramp.
- 11.** Lower the machine platform; the lockout cylinder should then release and allow the axle to oscillate. It may be necessary to activate DRIVE to release cylinders.
- 12.** If the lockout cylinders do not function properly, have qualified personnel correct the malfunction prior to any further operation.



## **SECTION 3. MACHINE CONTROLS, INDICATORS, AND OPERATION**

### **3.1 GENERAL**

#### **NOTICE**

**THE MANUFACTURER HAS NO DIRECT CONTROL OVER MACHINE APPLICATION AND OPERATION, THE USER AND OPERATOR ARE RESPONSIBLE FOR CONFORMING WITH GOOD SAFETY PRACTICES.**

This section provides the necessary information needed to understand controls and their functions.

#### **⚠ WARNING**

**DO NOT RAISE PLATFORM EXCEPT ON A SMOOTH, FIRM AND LEVEL SURFACE FREE OF OBSTRUCTIONS AND HOLES.**

**TO AVOID SERIOUS INJURY, DO NOT OPERATE MACHINE IF ANY CONTROL LEVERS OR TOGGLE SWITCHES CONTROLLING PLATFORM MOVEMENT DO NOT RETURN TO THE OFF OR NEUTRAL POSITION WHEN RELEASED.**

**IF THE PLATFORM DOES NOT STOP WHEN A CONTROL SWITCH OR LEVER IS RELEASED, USE THE EMERGENCY STOP SWITCH TO STOP THE MACHINE.**

### **3.2 DESCRIPTION**

This machine is a self-propelled aerial work platform on top of an elevating scissor arm mechanism. The Lift's intended purpose is to position personnel with their tools and supplies at positions above ground level. The machine can be used to reach work areas located above machinery or equipment positioned at ground level.

This JLG Lift has a primary operator control station in the platform. From this control station, the operator can drive and steer the machine in both forward and reverse directions, raise and lower the platform and set the machine leveling jacks.

The machine can be driven on a smooth, firm, and level surface from an elevated platform position - See "Traveling (Driving)" on page 3-18. of this manual for specific requirements.

The machine also has a ground control station which can override the platform control station. Ground controls operate lift up and down. Ground controls are to be used only in an emergency to lower the platform to the ground should the operator in the platform be unable to do so.

### 3.3 OPERATING CHARACTERISTICS AND LIMITATIONS

#### General

A thorough knowledge of the operating characteristics and limitations of the machine is always the first requirement for any user, regardless of user's experience with similar types of equipment.

#### Placards

Important points to remember during operation are provided at the control stations by DANGER, WARNING, CAUTION, IMPORTANT and INSTRUCTION placards. This information is placed at various locations for the express purpose of alerting personnel of potential hazards constituted by the operating characteristics and load limitations of the machine. See foreword for definitions of the above placards.

### 3.4 PLATFORM LOADING

The platform maximum rated load capacity is shown on a placard located on the platform billboard and is based upon the machine being positioned on a smooth, firm, and level surface. Refer to Section 6.3 for the maximum platform capacity.

The platform is entered through an entry gate on each side of the platform. Keep entry gate closed during machine operation.

**NOTE:** *It is important to remember that the load should be evenly distributed on the platform. The load should be placed near the center of the platform when possible.*

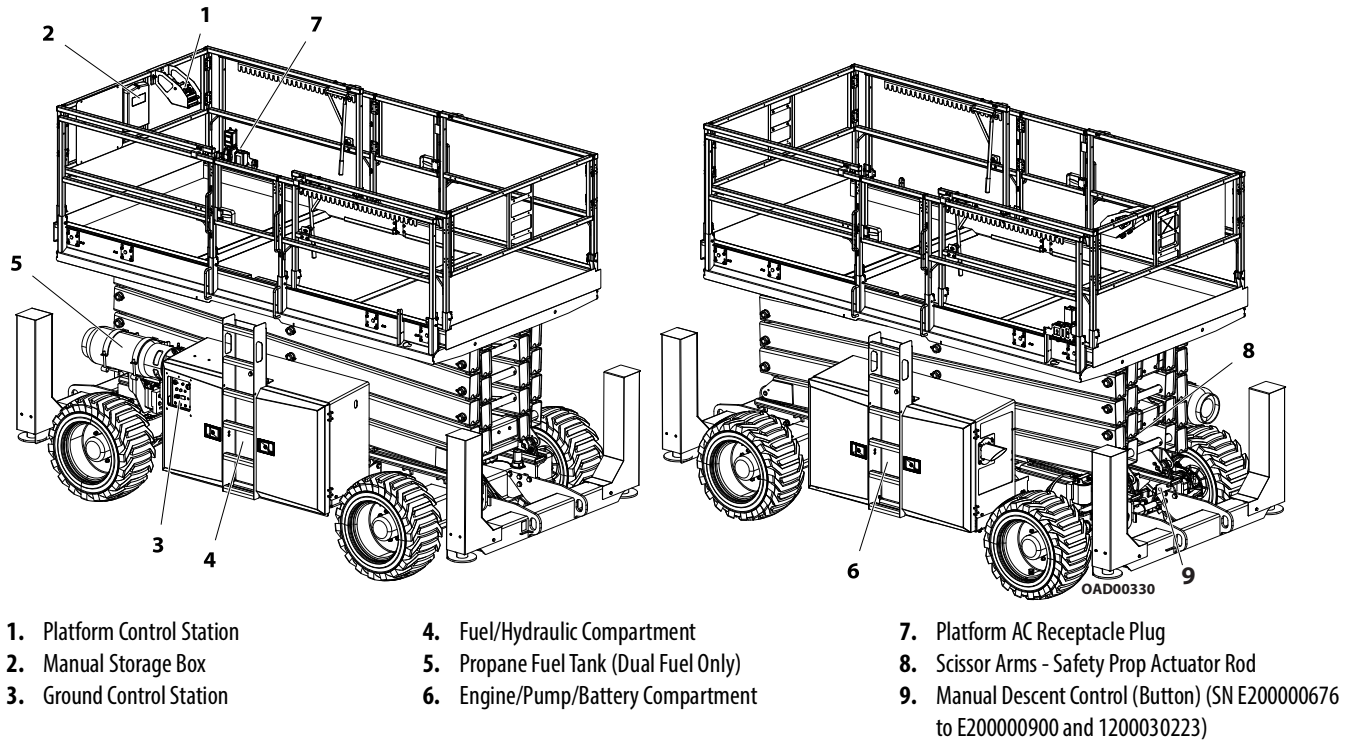

**Figure 3-1. Location of Machine Controls**

### 3.5 GROUND CONTROLS AND INDICATORS

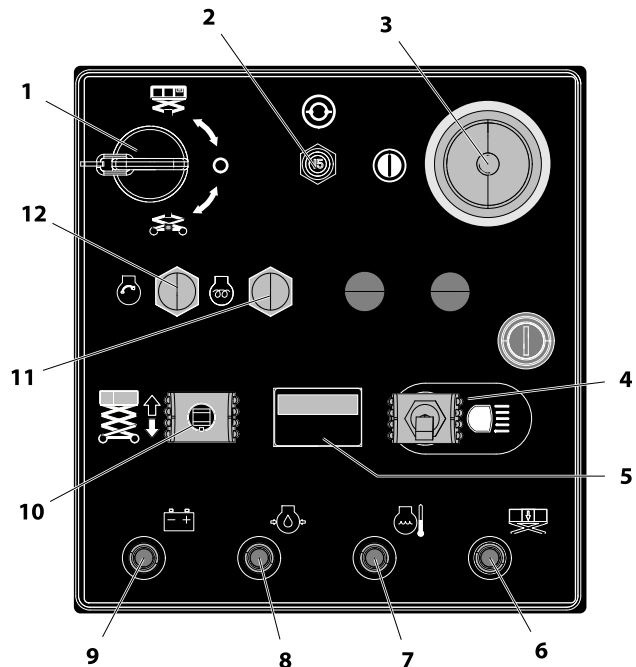

1. Platform/Off/Ground Control Select Switch
2. Circuit Breaker (15 Amp)
3. Emergency Stop Switch
4. Head and Tail Lights (If equipped)
5. Hourmeter
6. Platform Overload Indicator (If Equipped)
7. Water Temperature Indicator
8. Oil Pressure Indicator
9. Battery Indicator
10. Platform Lift/Lower
11. Glow Plug (Diesel Only)
12. Start Button

Figure 3-2. Ground Control Station

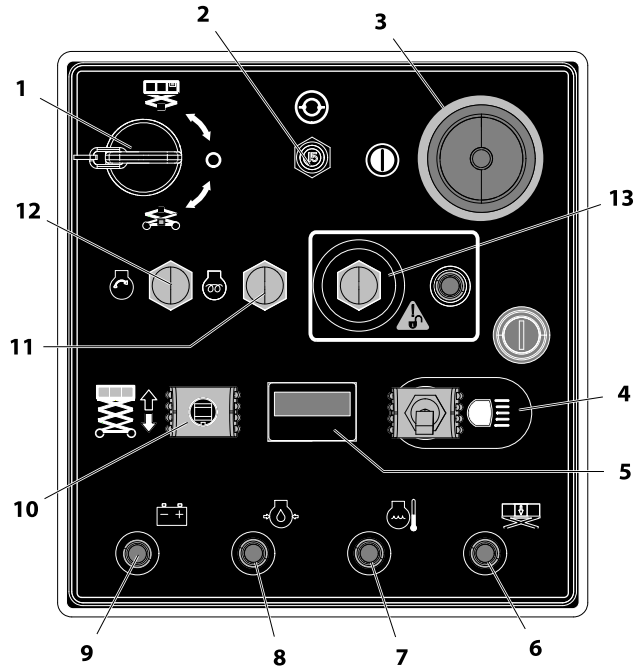

1. Platform/Off/Ground Control Select Switch
2. Circuit Breaker (15 Amp)
3. Emergency Stop Switch
4. Head and Tail Lights (If equipped)
5. Hourmeter
6. Platform Overload Indicator
7. Water Temperature Indicator
8. Oil Pressure Indicator
9. Battery Indicator
10. Platform Lift/Lower
11. Glow Plug (Diesel Only)
12. Start Button
13. Machine Safety System Override (MSSO)

**NOTE:** This Ground Control Station may also apply to SN 1200027648 through 1200027657.

**Figure 3-3. Ground Control Station (CE Only - Prior to SN E200000675)**

### Ground Control Station

(See Figure 3-2. or Figure 3-3.)

#### **⚠ WARNING**

**DO NOT OPERATE FROM GROUND CONTROL STATION WITH PERSONNEL IN THE PLATFORM EXCEPT IN AN EMERGENCY.**

#### 1. Platform/Off/Ground Control Select Switch -

A three position, key-operated power select switch supplies operating power to the platform or ground controls, as selected. When positioned to platform, the switch provides power to the emergency stop switch at the platform controls. When positioned to ground, the switch provides power to the ground control. The ground control emergency stop switch provides power to the key switch. With the power select switch in the center off position, power is shut off to both platform and ground controls and the key can be removed to disable the machine.

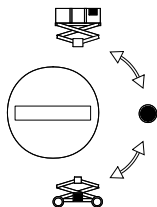

2. **Circuit Breaker** - The circuit breaker will open when there is a short or overload on the machine.



3. **Emergency Stop Switch** - A two-position, red, mushroom-shaped emergency stop switch, when positioned to ON with the power selector switch positioned to ground, furnishes operating power to the ground control station. In addition, the switch can be used to turn off power to the function controls in the event of an emergency. Power is turned on by pulling the switch out (on), and is turned off by pushing the switch in (off).

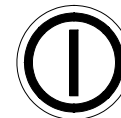



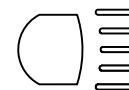



4. **Head and Tail Lights - ON/OFF Switch (If equipped)** - This toggle switch, when used, turns the head and tail lights on and off.

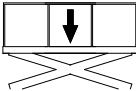

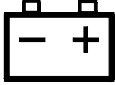
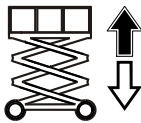

### SECTION 3 - MACHINE CONTROLS, INDICATORS, AND OPERATION

5. **Hourmeter** - The machine is equipped with an hour meter to indicate the number of hours the machine has been operated.
6. **Platform Overload Indicator (If equipped)** - Illuminates when the platform becomes overloaded.
7. **Water Temperature Indicator** - Illuminates when the engine is overheating.
8. **Oil Pressure Indicator** - Illuminates when the engine oil pressure drops too low.
9. **Battery Indicator** - Illuminates when the charge in the battery is low.
10. **Platform Lift/Lower Switch** - A three position, momentary contact lift control switch provides raising and lowering of the platform when positioned to lift up or down.  
In addition to normal operation, auxiliary descent allows lift down with power on and engine off.
11. **Glow Plug Switch - (Diesel Engine Only)** - A momentary contact, push button type switch that supplies electrical power to the engine's glow plugs, to assist cold starting. Once pressed, there is a 5 second default timer that will not allow the start button to function before this time has elapsed.
12. **Engine Start Switch** - A momentary contact, push button type switch that supplies electrical power to the starter solenoid when the emergency stop switch is in the ON position and the start button is depressed.
13. **Machine Safety System Override (MSSO) (CE Only - Prior to SN E20000675 and 1200027648 through 1200027657)** - Provides emergency override of platform up/down function controls that are locked out in the event of Load Sense System activation. Refer to Section 4 for more information.
- 000000  
HOURS
- 
- 
- 
- 
- 
- 
- 
- 

**NOTE:** Diesel engine cannot be started while glow plugs are on.

### Platform Auxiliary Descent (SN E200000676 to E200000900)

Use Platform Auxiliary Descent Control to lower the platform in situations where the engine is off but power is still supplied to the machine (emergency stop button at ground controls is pulled out). The yellow push-button is located on the front of the machine. Look for the instructional decal located beside the button.

#### Operation

1. Locate the button at the front of the machine.
2. Push and hold the button until the platform reaches its desired height, then release.

#### **⚠ WARNING**

**KEEP HANDS AND ARMS OUT OF THE PATH OF THE SCISSOR ARMS AND PLATFORM WHILE LOWERING.**

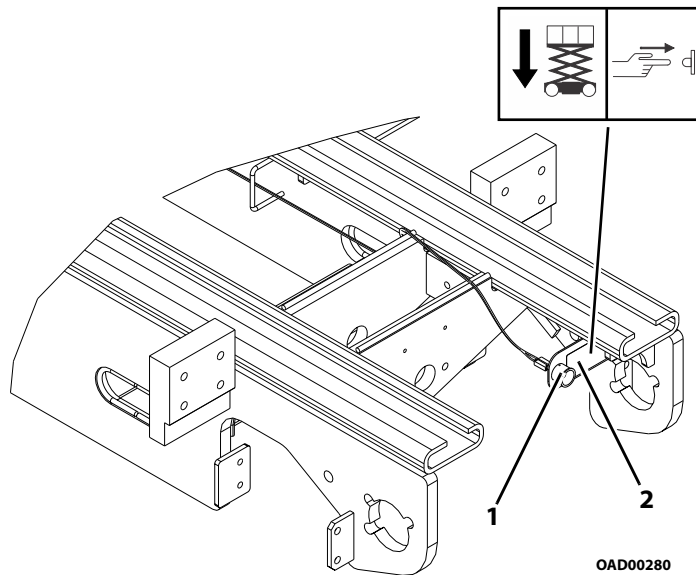

1. Auxiliary Descent Button

**NOTE:** Some components hidden for clarity.

3.6 PLATFORM CONTROL STATION

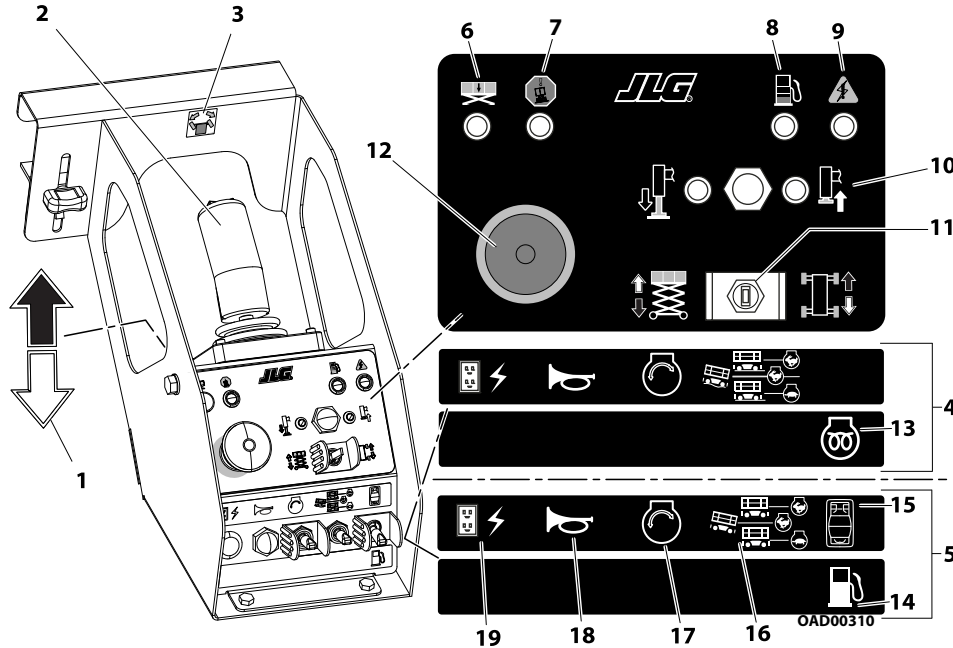

1. Direction Arrow Indicator
2. Controller with Trigger Switch/Steer Switch
3. Steer Switch Indicator Decal
4. Control Indicators - Diesel
5. Control Indicators - Dual Fuel
6. Overload Indicator (LSS) (If Equipped)
7. Machine Tilt Indicator
8. Low Fuel Level Indicator
9. System Fault Indicator
10. Leveling Jacks/LED Indicators (If Equipped)
11. Two-Position Drive/Lift Select Switch
12. Emergency Stop Switch
13. Glow Plug Switch (Diesel Only)
14. Gasoline Fuel Select (Dual Fuel Only)
15. Propane Fuel Select (Dual Fuel Only)
16. Speed Select Switch (High/Mid/Low)
17. Engine Start Switch
18. Horn Button
19. Generator Start Switch (Optional)

**NOTE:** This Platform Control Station may also apply to SN 1200027648 through 1200027657.

Figure 3-4. Platform Control Station (Prior to SN E20000675)

## SECTION 3 - MACHINE CONTROLS, INDICATORS, AND OPERATION

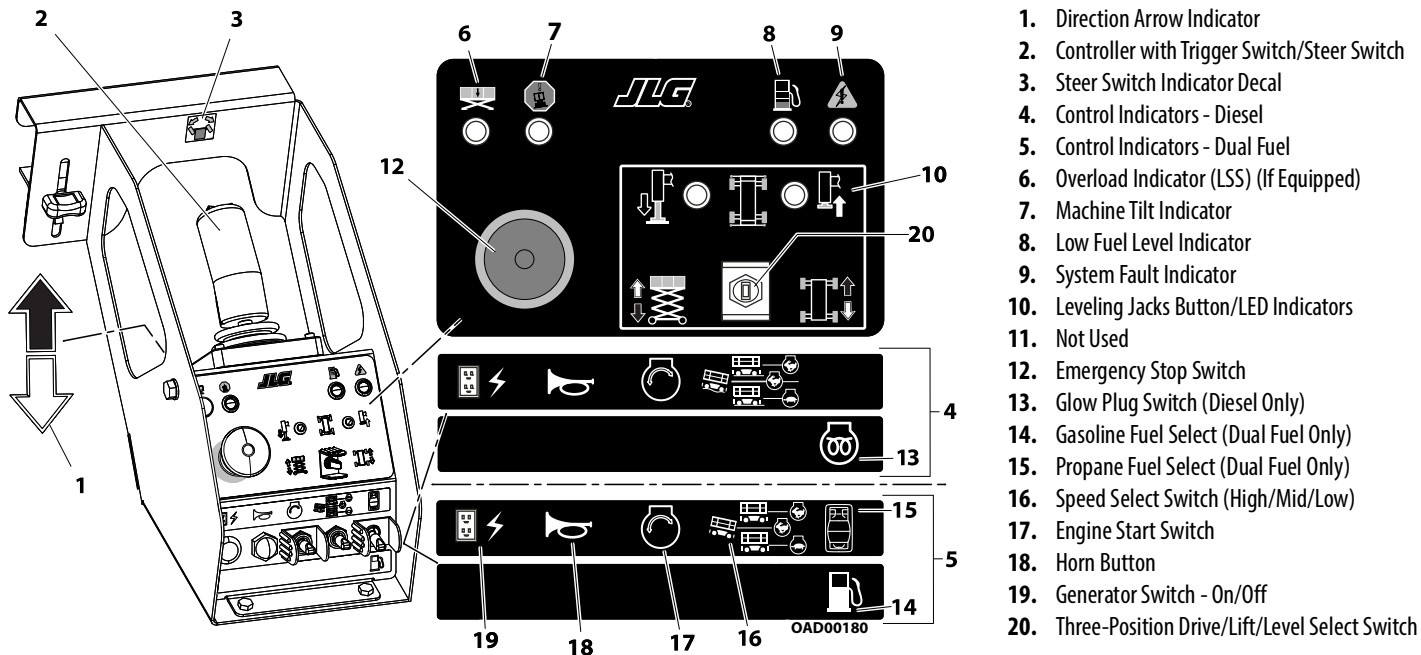

**NOTE:** This Platform Control station also applies to SN 1200030223.

**Figure 3-5. Platform Control Station (SN E20000676 to E20000900)**

### Platform Controls

#### NOTICE

CONTROL BOXES SHOULD NOT BE SWITCHED FROM ONE MACHINE TO ANOTHER.

- 1. Directional Arrow** - This arrow indicates the direction the joystick must be moved to operate machine functions. Notice the black and white ends of the arrow in relation to the control indicators.
- 2. Controller, Trigger Switch**
  - a. Control Handle and Trigger Switch** - The control handle controls four functions: drive, lift, leveling jacks and steer. The drive, lift, or leveling jack function switch must be selected and the trigger switch on the front of the control handle must be depressed and held, prior to moving the control handle and, during controller movement.

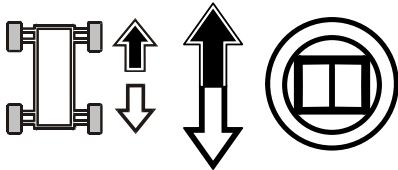

After selecting the drive function, depressing the trigger switch and moving the control handle forward will drive the machine forward and moving the control handle backwards will drive the machine backward.

After selecting the lift function, depressing the trigger switch and moving the control handle forward will lower the platform and moving the control handle backward will lift the platform up.

After selecting the leveling jack function, depressing the trigger switch and moving the control handle forward will extend all four leveling jacks, moving the hand controller backward will retract the leveling jacks.

The speed on all selected functions, (except leveling jacks), is proportionally controlled by the distance of travel of the hand controller.

**NOTE:** *If the machine is also equipped with a footswitch (Korean Specification only), the footswitch must be depressed in conjunction with the trigger (enable) switch located on the controller. Power is removed from the platform controls when the footswitch is released.*

## SECTION 3 - MACHINE CONTROLS, INDICATORS, AND OPERATION

### 3. Steer Switch/Leveling Trim Adjust -

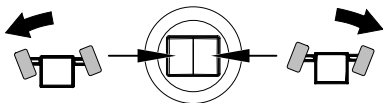

The steer switch/auto leveling trim adjust is located at the top of the control handle. Selecting the drive function then depressing the switch to the right will steer the wheels to the right. Depressing the switch to the left will steer the wheels to the left.

When auto leveling is selected this switch is used to manually adjust (trim) the leveling of the machine to the left or right. Refer to "The level adjustment of the machine may still be improved. Refer to Manual Level Adjustment (Trim)." on page 3-21 for leveling jack operating procedures.

### 4. Control Indicators - Diesel

### 5. Control Indicators - Dual Fuel

**6. Overload Indicator (LSS) (If Equipped)** - Indicates the platform has been overloaded. An audible alarm will also signal when the platform is overloaded.



**NOTE:** If the Overload Indicator is activated while elevated above 14 ft (4.26 m), all functions will be prevented from the platform and ground controls. Reduce the weight in the platform to not exceed the rated workload indicated on the capacity decal, then the controls will work again.

### 7. Tilt Indicator Warning Light and Alarm -

A red warning light on the control panel illuminates and an audible alarm sounds when the chassis is at or beyond the tilt cutout settings.

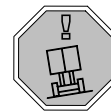

## ⚠ WARNING

**IF THE TILT INDICATOR WARNING LIGHT/ALARM IS ACTIVATED WHEN PLATFORM IS RAISED, LOWER PLATFORM AND DRIVE TO A SMOOTH FIRM LEVEL SURFACE.**

**8. Low Fuel Indicator** - This light will be illuminated when the fuel remaining in the fuel tank is getting low.

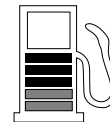

**9. System Fault Indicator** - This warning light will flash the appropriate distress code (flash code).



### 10. Leveling Jacks - To engage Leveling Jacks:

- **Prior to SN E20000675 and 1200027648 through 1200027657:** Press Leveling Jacks button. Set and Retract LEDs will illuminate on indicator pad when control handle engages those functions.
- **SN E20000676 to E20000900 and 1200030223:** Select the Level function on the three-position switch. Set and Retract LEDs will illuminate on indicator pad when control handle engages those functions.

Moving control handle forward will lower leveling jacks. Moving control handle backward will raise leveling jacks. Once the machine is level, leveling jacks will stop extending and both LEDs will stop blinking and remain lit.

**Leveling Jacks Set** - This indicator light will blink when the leveling jacks are being extended.

**Leveling Jacks Retracting** - This indicator light will blink when the leveling jacks are being retracted.

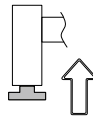
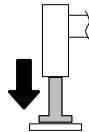

**NOTE:** After initial ground contact is made, the auto level function will pause 2-5 seconds and then begin to properly level the machine.

**NOTE:** There is an override feature on the Auto Leveling system that allows the operator to adjust (trim) the level of the machine to the left or right when the platform is completely lowered. Use the following instructions to adjust the level of the machine.

- a. With the leveling jack switch activated, squeeze trigger switch on the controller.
- b. To adjust the leveling jacks to the left, activate the switch on top of the controller to the left. To adjust to the right, activate the switch on top of the controller to the right. The leveling jack indicator light for the side selected will be lit.

## SECTION 3 - MACHINE CONTROLS, INDICATORS, AND OPERATION

### 11. Two-Position Drive/Lift Select Switch

a. **Drive Select Switch** - When selected, the drive function will be active. Depress the trigger switch and move the control handle in the forward or reverse direction will cause drive motion to occur at a speed determined by the range selected by the speed switch and the distance the controller is moved from center.

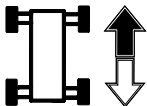

b. **Lift Select** - When selected, the lift/lower function will be active. Depress the trigger switch and move the control handle in the forward or reverse direction will cause platform motion to occur at a speed determined by the distance the controller is moved from center.

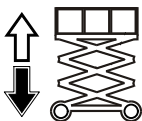

In addition to normal operation, auxiliary descent allows lift down with power on and engine off.

### CAUTION

**DO NOT "LIFT DOWN" WITHOUT COMPLETELY RETRACTING THE PLATFORM EXTENSION(S).**

12. **Emergency Stop Switch** - A two-position, red, mushroom-shaped emergency stop switch functions to provide power to the platform control station and also to turn off power to the platform function controls in the event of an emergency. With the power select switch positioned to platform, power is turned on by pulling the switch out (on), and is turned off by pushing the switch in (off).



13. **Glow Plug Switch** - (*Diesel Engine Only*) - A momentary contact, push button type switch that supplies electrical power to the engine's glow plugs, to assist cold starting. Once pressed, glow plugs are active for 20 seconds. Allow glow plugs a few seconds to heat up before starting the engine within the timeframe.



14. **Gasoline Fuel Select** - In this position the switch is set up to change from propane to gasoline on a machine equipped with the dual fuel option.

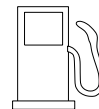

15. **Propane Fuel Select** - In this position the switch is set up to change from gasoline to propane on a machine equipped with the dual fuel option.

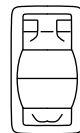



- 16. Speed Switch** - With the platform lowered, the three position speed switch permits the operator to select either high speed (3.5 mph - 5.6 kph), mid speed (2.0 mph - 3.21 kph), or low speed (1.0 mph - 1.61 kph). All three speeds use high engine speed. When platform is elevated above high drive cutout height, drive speed is reduced to (0.5 mph) regardless of Speed Switch setting.

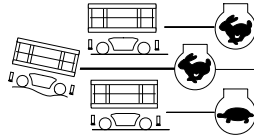

**⚠ CAUTION**

**DO NOT USE HIGH RANGE WHEN DRIVING IN CLOSE QUARTERS OR WHEN DRIVING IN REVERSE.**

**NOTE:** High/mid/low drive speeds are disabled when the platform is raised above the high drive cutout height (refer to Table 2-2 on page 2-10). When platform is lowered below high drive cutout height, high/mid/low drive speeds are enabled.

**⚠ CAUTION**

**DO NOT OPERATE MACHINE IF HIGH DRIVE SPEED OPERATES WHEN PLATFORM IS RAISED ABOVE THE HIGH DRIVE CUTOUT HEIGHT.**

- 17. Engine Start Switch** - A momentary contact, toggle switch that supplies electrical power to the starter solenoid when the emergency stop switch is in the ON position and the toggle switch is toggled upwards.



- 18. Horn** - This push-button switch, when activated, permits the operator to warn jobsite personnel when the machine is operating in the area.



- 19. Generator Start Switch** - (Optional) - This toggle switch, when used, turns the generator on and sets the engine speed.

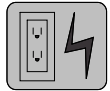

### 20. Three-Position Drive/Lift/Level Select Switch -

Machines from SN E200000676 to E200000900 and 1200030223 are equipped with a three-position switch that engages Drive/Lift/Level functions.

- a. **Drive Select** - When selected, drive function is active (refer to item 12).
- b. **Lift Select** - When selected, lift/lower functions are active (refer to item 12).
- c. **Level Select** - When selected, leveling jacks functions are active. Depress trigger switch and move control handles forward to lower leveling jacks, and move control handle backward to raise leveling jacks.

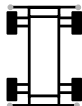

### 3.7 ENGINE OPERATION

**NOTE:** When operating a machine at high altitudes, a decrease in machine performance may occur due to a decrease in air density.

When operating a machine at high ambient temperatures, a decrease in machine performance and an increase in engine coolant temperature may occur. Contact JLG Customer Service for operation under abnormal conditions.

#### Starting Procedure

**NOTE:** Perform initial start-up from the Ground Control Station.

1. Check engine oil before attempting to start engine; if necessary, add oil.
2. Pull out the red emergency stop switch (ON).
3. Position the platform/ground select switch to the desired operating control station (platform or ground).
4. If operating a dual fuel machine, place the LPG/GASOLINE select switch in the platform to the desired position.

**NOTE:** If LPG system is selected, ensure the hand valve on LPG supply tank is opened prior to attempting to start engine.

**NOTICE**

IF ENGINE FAILS TO START PROMPTLY, DO NOT CRANK FOR AN EXTENDED PERIOD; DO NOT RUN STARTER MOTOR FOR MORE THAN 20 SECONDS. SHOULD ENGINE FAIL TO START ONCE AGAIN, ALLOW STARTER TO "COOL OFF" FOR 2 TO 3 MINUTES. IF ENGINE FAILS TO START AFTER SEVERAL ATTEMPTS, REFER TO ENGINE MANUAL.

5. To start machine:

- **At Ground Controls:** Position emergency stop switch to on, depress start button, and hold until engine starts.
- **At Platform Controls:** Position ground and platform emergency stop switches to on, toggle start switch, and hold until engine starts.

If necessary, activate glow plug switch for up to 20 seconds before starting engine if temperature is below 50° F (10° C).

**NOTICE**

IF INDICATOR LIGHTS REMAIN LIT AFTER ENGINE START-UP, STOP ENGINE IMMEDIATELY AND DETERMINE CAUSE.

**NOTICE**

ALLOW ENGINE TO WARM UP BEFORE APPLYING ANY LOAD.

6. After engine has warmed, proceed with operation.

### 3.8 DUAL FUEL SYSTEM (IF EQUIPPED)

**⚠ CAUTION**

IT IS POSSIBLE TO SWITCH FROM ONE FUEL SOURCE TO THE OTHER WITHOUT ALLOWING THE ENGINE TO STOP. EXTREME CARE MUST BE TAKEN AND THE FOLLOWING INSTRUCTIONS MUST BE FOLLOWED.

#### Changing from Gasoline to Liquid Propane Gas (LPG)

1. Start the engine from the platform control station.
2. With engine under a no-load condition, turn hand valve on LPG supply tank counterclockwise.
3. While engine is operating, place two-position LPG/GAS SELECT switch at the platform control station to LPG.

#### Changing from LPG to Gasoline:

1. With the engine operating on LPG under a no-load condition, position the LPG/GAS SELECT switch at the platform station to the GAS SELECT position.
2. If engine 'stumbles' due to lack of gasoline, return switch to LPG position until engine regains smoothness, then move switch to GAS SELECT position. Repeat as necessary until the engine runs smoothly on gasoline.
3. Close the hand valve on the LPG supply tank by turning clockwise.

### **3.9 OPERATING CHARACTERISTICS**

#### **Platform Loading**

The platform maximum rated load capacity is shown on a placard located on the platform and is based upon the following criteria:

1. The machine is positioned on a smooth, firm and level surface.
2. All braking devices are engaged.
3. The maximum platform capacity is as follows:

Total Platform Capacity including Extension(s)	1500 lb (680 kg)
Platform Extension(s) Capacity	500 lb (227 kg)

**NOTE:** *It is important to remember that the load should be evenly distributed on the platform. The load should be placed near the center of the platform when possible.*

#### **Traveling (Driving)**

##### **WARNING**

**DO NOT DRIVE WITH PLATFORM RAISED EXCEPT ON A SMOOTH, FIRM AND LEVEL SURFACE FREE OF OBSTRUCTIONS AND HOLES. TO AVOID LOSS OF TRAVEL CONTROL OR UPSET ON GRADES AND SIDESLOPES, DO NOT DRIVE MACHINE ON GRADES OR SIDESLOPES EXCEEDING THOSE SPECIFIED IN SECTION 6.**

#### **Traveling Forward**

1. Position the platform Emergency Stop Switch to the on position.
2. After starting engine press the drive select switch and move the control grip forward and hold for the duration of travel. Drive speed is determined by the distance the control handle is moved from the center off position. For additional drive speed, position the high speed switch to high while operating in the drive forward mode.

### Traveling in Reverse

1. Position the emergency stop switch at the platform control station to the on position.
2. Press the drive switch and move the control handle backward (reverse) and hold for the duration of travel. Drive speed is determined by the distance the control handle is moved from the center off position. Do not activate the high engine speed switch when traveling in reverse.

### Traveling on Grade

If driving at high drive up a grade and the incline exceeds 8° incline, the drive function will cut back to mid drive speed. The drive pump will shift back into high drive once the incline decreases to 5°. There will be a 2 second delay before the machine goes back to high drive.

### Steering

**NOTE:** *When static steering is performed it will bring the engine up to high speed.*

To steer the machine, the thumb operated steer control switch on the controller handle is positioned to the right for traveling right, or to the left for traveling left. When released, the switch will return to the center-off position and the wheels will remain in the previously selected position. To return the wheels to the straightened position, the switch must be activated in the opposite direction until the wheels are centered.

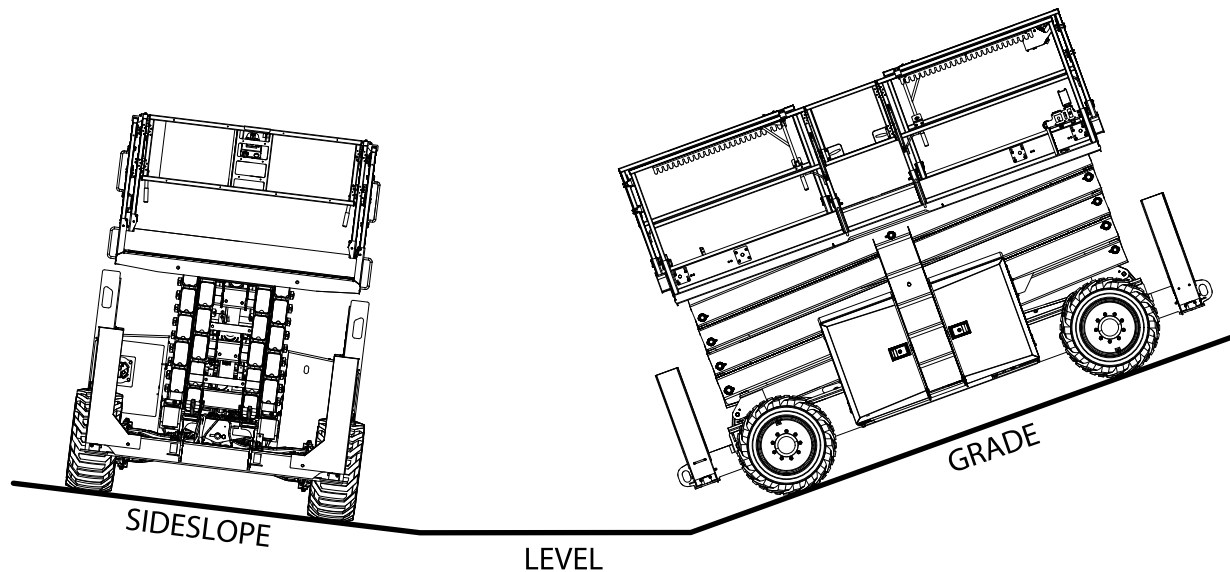

**Figure 3-6. Grade and Sideslope**

### Leveling Jack Operation

The machine is equipped with auto leveling jacks with a manual adjust feature. These leveling jacks are activated through one switch on the platform console.

**NOTE:** Prior to SN E200000675 and 1200027648 through 1200027657, engine speed will drop when leveling jacks are activated. From SN E200000676 to E200000900 and 1200030223, engine speed will run at high idle.

### Auto Leveling

1. With the platform in the stowed position, turn on the power and start machine.
  - a. Prior to SN E200000675 and 1200027648 through 1200027657, press the Leveling Jacks button on the platform control console.
  - b. From SN E200000676 to E200000900 and 1200030223, select the Level function on the three-position switch on the platform control console.
2. While squeezing the trigger switch on the controller, move the controller forward to lower the leveling jacks.
3. Once the leveling jacks make contact with the ground surface, there will be up to a 5 second delay before the actual auto leveling begins.

**NOTE:** Due to varying ground conditions, there may be several delays between machine level corrections. Allow ample time for all leveling adjustments to be completed.

4. Continue to engage the leveling jacks until the extend jacks LED stops blinking and is lit solid.

**NOTE:** The level adjustment of the machine may still be improved. Refer to Manual Level Adjustment (Trim).

**NOTE:** If you receive a 2/5 flash code through the system fault light at the platform control station the machine is unable to level. Reposition and try again.

5. To retract the leveling jacks, depress the leveling jack selector switch and move the controller backward until the jacks are fully retracted.

**NOTE:** There is a limit switch that senses when all four cylinders are fully retracted and this will light up the leveling jacks retracted LED on the platform control station.

Prior to SN E200000675 and 1200027648 through 1200027657, the proximity (elevation) sensor and the rotary angle (elevation) sensor work in conjunction to determine the machine is stowed. From SN E200000676 to E200000900 and 1200030223, the arm stack tilt sensor and the rotary angle (elevation) sensor work in conjunction to determine the machine is stowed. Failure of any of these sensors will prevent leveling jacks operation.

### Manual Level Adjustment (Trim)

**NOTE:** *There is an override feature on the Leveling Jack system that allows the operator to adjust (trim) the level of the machine to the left or right when the platform is completely lowered. Use the following instructions to adjust the level of the machine.*

1. With the machine in the stowed position turn the power on, start machine, and engage Leveling Jacks function.
2. To adjust (trim) the machine to the right, activate the steer switch on the top of the controller to the right until the desired position is reached.
3. To adjust (trim) the machine to the left, activate the steer switch on the top of the controller to the left until the desired position is reached.

**NOTE:** *Anytime the trim function is used there is a possibility that the machine may become out of level. At this time the machine will no longer lift but the machine can be lowered.*

**NOTE:** *The machine must be in the stowed position before the trim function is operable.*

### Raising and Lowering Platform



**DO NOT RAISE PLATFORM EXCEPT ON A SMOOTH, FIRM AND LEVEL SURFACE FREE OF OBSTRUCTIONS AND HOLES.**

A flow control valve controls both lift up and lift down speeds. Anytime lift direction abruptly changes, there is a three second delay between lift up and lift down.

When raising platform without leveling jacks set, platform elevation height is restricted as shown in Table 2-3.

### Raising

1. Position the applicable emergency stop switch(s) to the ON position.
1. With the engine running, place the power select switch to desired position (platform or ground).
2. If operating from the ground controls, position the lift switch to up and hold until desired elevation is achieved. If operating from the platform controls, set the lift/drive switch to lift, depress the trigger switch, then move the control handle backward and hold until desired elevation is reached. Lift speed is determined by the distance the control handle is moved from the off center position.



### Lowering

#### **⚠ WARNING**

ENSURE SCISSOR ARM AREA IS FREE OF PERSONNEL PRIOR TO LOWERING PLATFORM.

ENSURE PLATFORM EXTENSION(S) IS COMPLETELY RETRACTED PRIOR TO LOWERING PLATFORM.

- If operating from the ground controls, position the lift switch to down and hold until desired elevation is achieved or until platform is fully lowered.
- If operating from the platform controls, press the lift switch and then move the control handle forward and hold until desired elevation is reached or until platform is fully lowered.

### Platform Extension

The machine is equipped with either single or dual deck extensions, which add 4 ft (1.2 m) to the front or rear of the platform, giving the operator better access to worksites.

To extend the deck, lift handle up on the right side of the platform (when facing deck extension) to release the latch and use the handle to push the extendible deck out. When the deck reaches the end of its travel, push handle down to latch, this will lock and hold the deck in place. To retract the

deck, reverse operation. Maximum capacity for each deck extension is 500 lb (227 kg).

#### **⚠ WARNING**

DO NOT 'LIFT DOWN' WITHOUT COMPLETELY RETRACTING THE PLATFORM EXTENSION.

### Platform Cable Hook

Use the hook in the platform to store excess platform cable when platform is retracted.

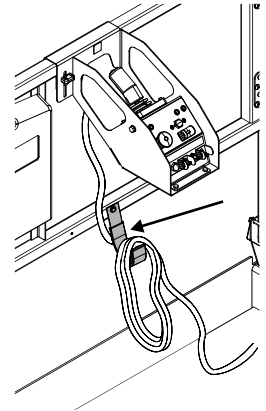

### 3.10 PLATFORM RAILS FOLD-DOWN PROCEDURE

Refer to Figure 3.8 and Figure 3.9 for fold-down procedure illustrations.

#### **WARNING**

**DO NOT RAISE PLATFORM WITH RAILS FOLDED DOWN. THE RAILS MUST BE IN THE UPRIGHT POSITION AND PROPERLY PINNED WHEN RAISING THE PLATFORM.**

**NOTE:** *The rails must only be folded down when the machine is in the stowed (platform fully lowered) position.*

*The platform control box should be removed from the platform rail before the side rails are folded down.*

The platform end rails swing in first and are folded down with the side rails they are hinged to. If platform is equipped with one or more platforms extension(s) both the main platform rails and the extension platform rails will be folded down together.

1. Remove platform control box and place it on platform deck.
2. Pull platform end rail pins (two pins per end rail) and swing platform end rail into side rails.
3. Pull platform side rail pins (four per rail set).

4. To fold down each set of side rails, take hold of the top rail and lower towards the platform until it is fully folded.
5. To raise the rails back to the upright position, unfold the rails in the reverse sequence they were folded. Firmly pull the rails back up into position and replace the bail pins into the rails.

**NOTE:** *When returning platform side rails to upright position on platforms equipped with extensions, ensure the extension platform rail guide is interlocked over the main platform rail once both rails are completely upright.*

#### **WARNING**

**AFTER THE RAILS HAVE BEEN FOLDED DOWN, USE EXTREME CAUTION WHEN EXITING AND ENTERING THE PLATFORM. ENTER AND EXIT PLATFORM ONLY AT THE GATE AREA AND LADDER PROVIDED.**

#### **WARNING**

**IF OPERATING (DRIVING) MACHINE WITH PLATFORM CONTROL STATION FROM GROUND, WITH RAILS FOLDED, KEEP AT LEAST 3 FT (1 M) DISTANCE FROM MACHINE.**

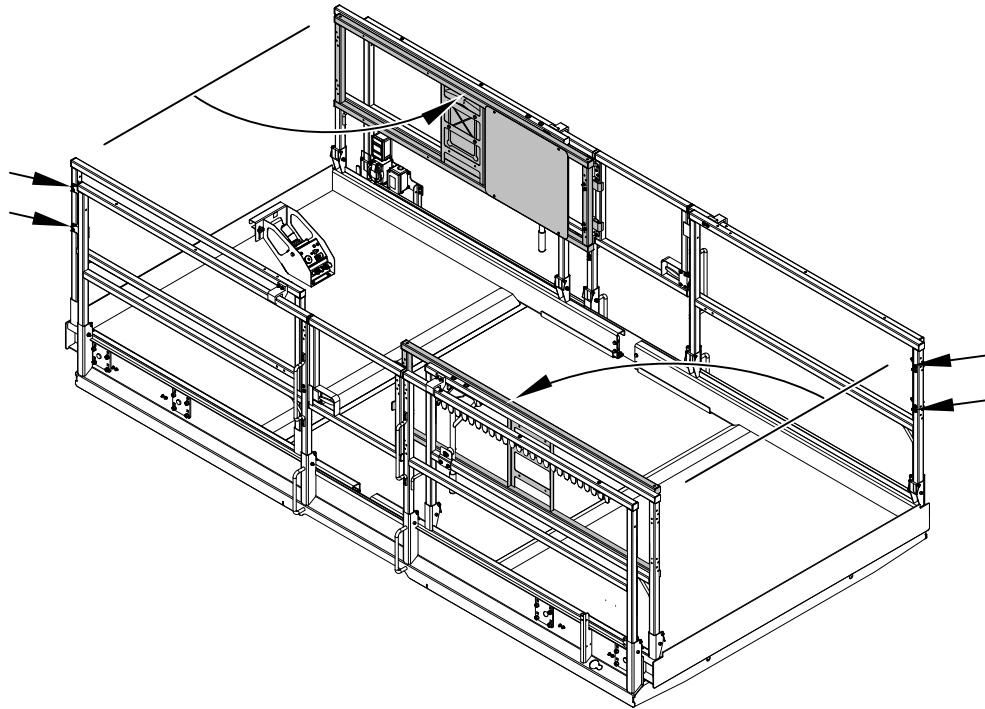

**Figure 3-7. Platform End Rails - Fold Down Sequence**

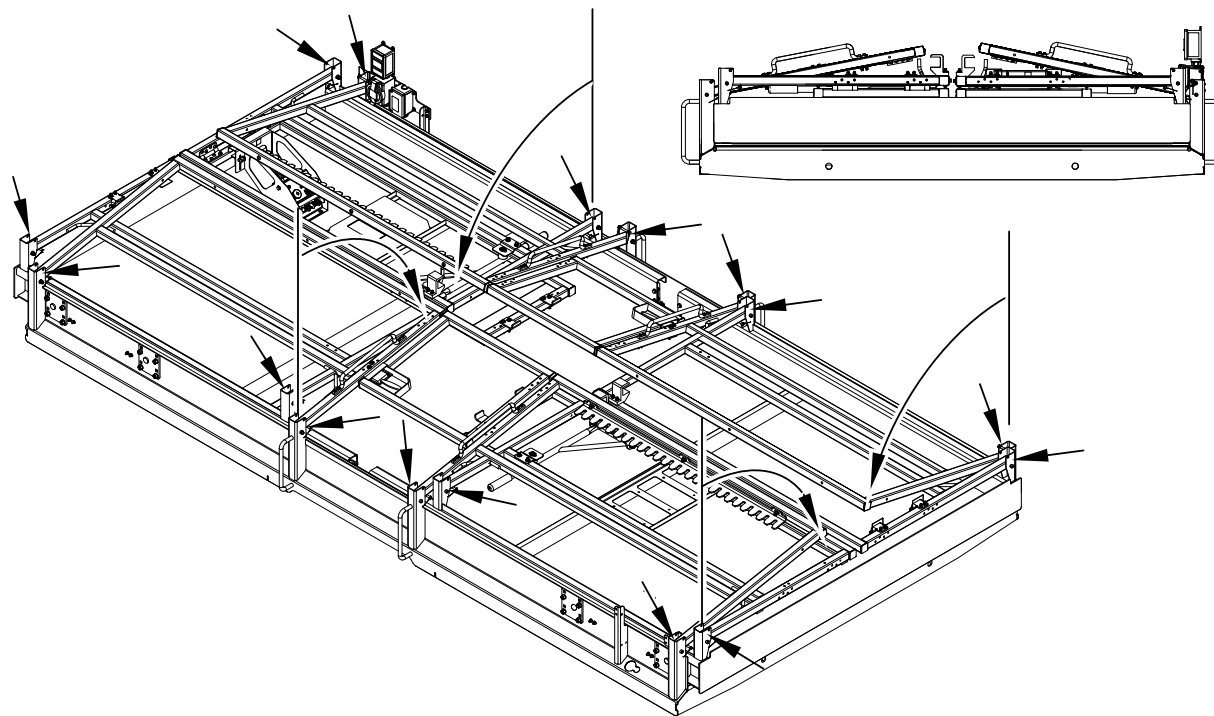

**Figure 3-8. Platform Side Rails - Fold Down Sequence**

### 3.11 PARKING AND STOWING

Park and stow the machine as follows:

1. Drive the machine to a reasonably well-protected and well-ventilated area.
2. Ensure the platform is fully lowered.
3. Position the emergency stop switch to the off position.
4. If necessary, cover the instruction placards, caution and warning decals so that they will be protected from hostile environment.
5. Chock at least two wheels when parking the machine for an extended period of time.
6. Turn the platform/off/ground control select switch to off and remove the key to disable the machine and prevent unauthorized use.

### 3.12 TIE DOWN/LIFT LUGS

#### Tie Down

When transporting the machine, the platform extensions must be fully retracted and the platform fully lowered in the stowed position with the machine securely tied down to the truck or trailer deck. Refer to the four tie down/lift lugs eyes as shown in Figure 3-10.

#### Lifting

If it becomes necessary to lift the machine, it is possible to do so from the tie down/lift lugs. These lugs enable the machine to be lifted using cranes or other suitable lifting devices.

**NOTE:** *If lifting becomes necessary from the lifting lugs, JLG Industries Inc. recommends the use of a proper spreader bar to avoid damage to the machine. Cranes or other lifting devices must be capable of handling the weights listed in Section 6.*

### 3.13 TOWING

It is not recommended that this machine be towed, except in the event of an emergency such as a machine malfunction or a total machine power failure. Refer to Section 4.2 for emergency towing procedures.

## SECTION 3 - MACHINE CONTROLS, INDICATORS, AND OPERATION

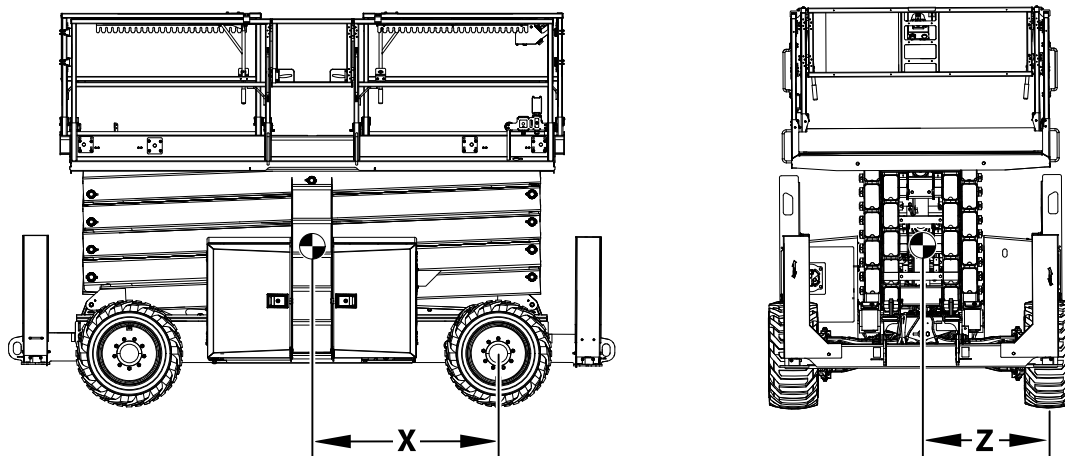

MODEL	WHEELBASE		X		Z	
	(in)	(cm)	(in)	(cm)	(in)	(cm)
530LRT	117	297	58.5	148.5	39.2	99.5

Figure 3-9. Lifting and Tie Down Chart (Sheet 1 of 2)

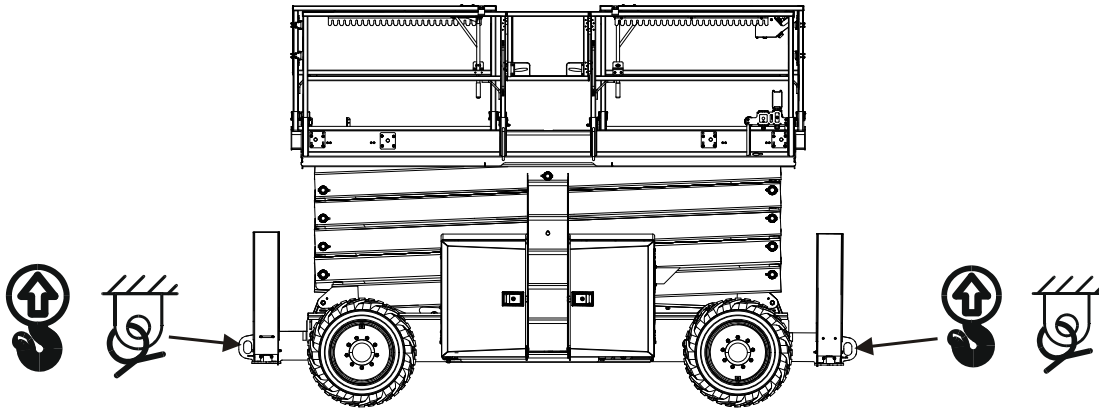

Figure 3-10. Lifting and Tie Down Chart (Sheet 2 of 2)





## **SECTION 4. EMERGENCY PROCEDURES**

### **4.1 GENERAL**

This section provides information on the procedures to be followed and on the systems and controls to be used in the event an emergency situation is encountered during machine operation. Prior to operation of the machine and periodically thereafter, the entire operating manual, including this section, should be reviewed by all personnel whose responsibilities include any work or contact with the machine.

### **4.2 EMERGENCY TOWING PROCEDURES**

Towing this machine is prohibited, unless properly equipped. However, provisions for moving the machine, in case of a malfunction or power failure, have been incorporated. The following procedures are to be used **ONLY** for emergency movement to a suitable maintenance area.

- 1.** Chock wheels securely.
- 2.** Disengage drive hubs by reversing disconnect caps.
- 3.** Connect suitable equipment, remove chocks, and move machine.
- 4.** After moving machine, complete the following procedures:
  - a.** Position machine on a firm and level surface.
  - b.** Chock wheels securely.
  - c.** Engage drive hubs by reversing disconnect caps on hubs.
  - d.** Remove chocks from wheels as needed.

### 4.3 EMERGENCY CONTROLS AND LOCATIONS

#### Emergency Stop Switch

These large red buttons, one located at the Ground Control Station and one at the Platform Control Station, will immediately stop the machine when depressed.

#### **WARNING**

**CHECK MACHINE DAILY TO MAKE SURE EMERGENCY STOP BUTTON IS IN PLACE AND THAT GROUND CONTROL INSTRUCTIONS ARE IN PLACE AND LEGIBLE.**

#### Ground Control Station

The Ground Control Station is located on the left side of the machine frame. The controls on this panel provide the means for overriding the platform controls and for controlling the platform lift up and down functions from the ground. Place the power select switch in the ground position and operate the lift switch to lift up or down.

### 4.4 EMERGENCY OPERATION

#### Use of Ground Controls

#### **NOTICE**

**KNOW HOW TO USE THE GROUND CONTROLS IN AN EMERGENCY SITUATION.**

Ground personnel must be thoroughly familiar with the machine operating characteristics and the ground control functions. Training should include operation of the machine, review and understanding of this section and hands-on operation of the controls in simulated emergencies.

#### Operator Unable to Control Machine

1. Operate the machine from ground controls **ONLY** with the assistance of other personnel and equipment (cranes, overhead hoists, etc.) as may be required to safely remove the danger or emergency condition.
2. Other qualified personnel on the platform may use the platform controls. **DO NOT CONTINUE OPERATION IF CONTROLS DO NOT FUNCTION NORMALLY.**
3. Cranes, forklift trucks or other equipment which may be available are to be used to remove platform occupants and stabilize motion of the machine in case machine controls are inadequate or malfunction when used.

## **Machine Safety System Override (MSSO)(CE Only)**

**NOTE:** *This system applies to machines prior to SN E200000675 and 1200027648 through 1200027657.*

The Machine Safety System Override (MSSO) is only to be used to retrieve an operator that is pinned, trapped, or unable to operate the machine and function controls are locked out from the platform due to a platform overload situation.



**NOTE:** *If the MSSO functionality is used, the fault indicator will flash and a fault code is set in the JLG Control System which must be reset by a qualified JLG Service Technician.*

**NOTE:** *No functional checks of the MSSO system are necessary. The JLG Control system will set a Diagnostic Trouble Code if the control switch is faulty.*

### **To operate the MSSO System:**

1. From the ground control console (see Figure 3-3. on page 3-5), place the Platform/ Ground Select switch in the Ground position.
2. Press and hold the MSSO switch, the RED LED next to the MSSO switch will blink when the MSSO system is activated.

3. With the MSSO activated, carefully operate the platform up/down switch to raise or lower the platform to the desired level.

## **Platform Caught Overhead**

If the platform becomes jammed or snagged in overhead structures or equipment, do the following:

1. Shut off the machine.
2. Rescue all people in the platform before freeing the machine. Personnel must be out of the platform before operating any controls on the machine.
3. Use cranes, forklifts or other equipment to stabilize motion of the machine to prevent a tip over as required.
4. From the ground controls, carefully free the platform from the object.
5. Once clear, restart the machine and return the platform to a safe position.
6. Inspect the machine for damage. If the machine is damaged or does not operate properly, turn off the machine immediately. Report the problem to the proper maintenance personnel. Do not operate the machine until it is declared safe for operation.

### Righting of Tipped Machine

A forklift of suitable capacity or equivalent equipment should be placed under the elevated side of the chassis, with a crane or other suitable lifting equipment used to lift the platform while the chassis is lowered by the forklift or other equipment.

### Post-Incident Inspection

Following any incident, thoroughly inspect the machine and test all functions first from the ground controls, then from the platform controls. Do not lift above 10 feet (3 meters) until you are secure that all damage has been repaired, if required, and that all controls are operating correctly.

### Platform Auxiliary Descent (SN E20000676 to E20000900)

Use Platform Manual Descent Control to lower the platform in situations where the engine is off but power is still supplied to the machine (emergency stop button at ground controls is pulled out). The yellow push-button is located on the front of the machine. Look for the instructional decal located beside the button.

#### OPERATION

1. Locate the button at the front of the machine.
2. Push and hold the button until the platform reaches its desired height, then release.

#### **WARNING**

**KEEP HANDS AND ARMS OUT OF THE PATH OF THE SCISSOR ARMS AND PLATFORM WHILE LOWERING.**

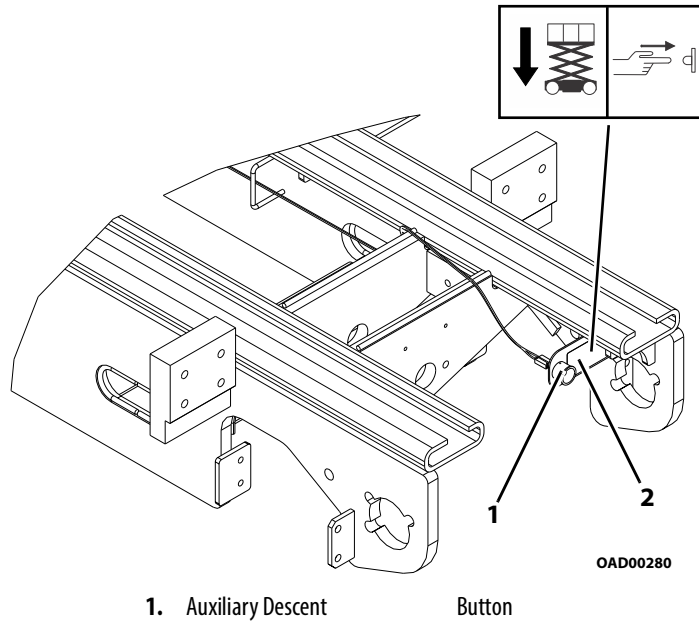

**Figure 4-1. Platform Auxiliary Descent Location**

**NOTE:** Some components hidden for clarity.

## 4.5 INCIDENT NOTIFICATION

JLG Industries, Inc. must be notified immediately of any incident involving a JLG product. Even if no injury or property damage is evident, JLG must be contacted by telephone and provided with all necessary details.

- USA: 877-JLG-SAFE (554-7233)
- EUROPE: (32) 0 89 84 82 20
- AUSTRALIA: (61) 2 65 811111
- E-mail: productsafety@jlg.com

Failure to notify the manufacturer of an incident involving a JLG Industries product within 48 hours of such an occurrence may void any warranty consideration on that particular machine.

### **NOTICE**

**FOLLOWING ANY INCIDENT, THOROUGHLY INSPECT THE MACHINE. DO NOT ELEVATE PLATFORM UNTIL YOU ARE SURE THAT ALL DAMAGE HAS BEEN REPAIRED, AND THAT ALL CONTROLS ARE OPERATING CORRECTLY. TEST ALL FUNCTIONS FIRST FROM THE GROUND CONTROL STATION, THEN FROM THE PLATFORM CONTROL CONSOLE.**



**SECTION 5. ACCESSORIES**

**Table 5-1. Available Accessories**

Accessory	Market						
	ANSI (USA Only)	ANSI	CSA	CE	AUS	Japan	China
1/2 Airline	√	√	√	√	√	√	√
Platform Worklights	√	√	√	√	√	√	√
Pipe Racks	√	√	√	√	√	√	√
Workstation	√	√	√	√	√	√	√
Large Material Racks	√	√	√	√	√	√	√

**5.1 1/2 AIRLINE**

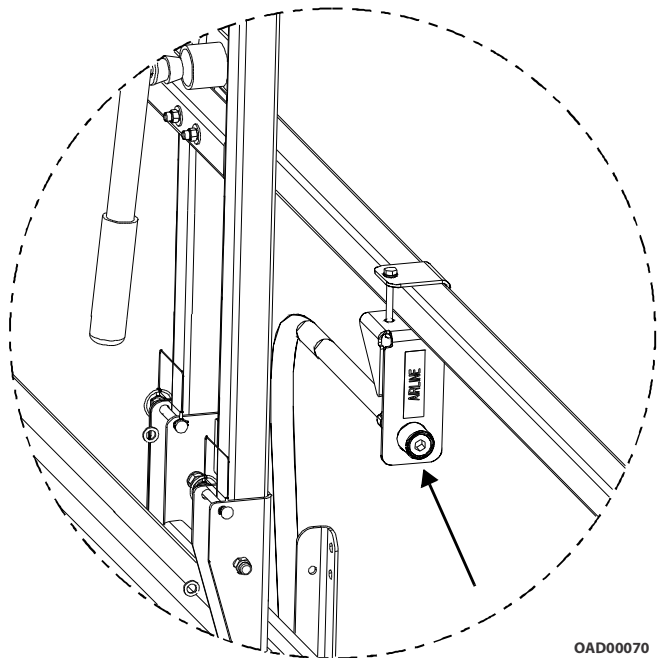

OAD00070

The 1/2 Airline is a fitting for air-powered tools that is mounted in the platform.

**5.2 PLATFORM WORKLIGHTS**

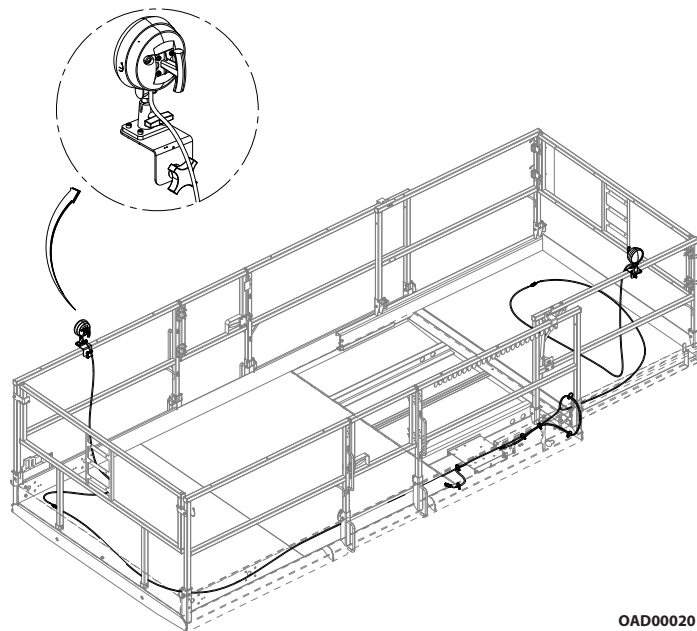

OAD00020

The Platform Worklights accessory consists of two 12V lights mounted to the platform railings.



### 5.3 PIPE RACKS

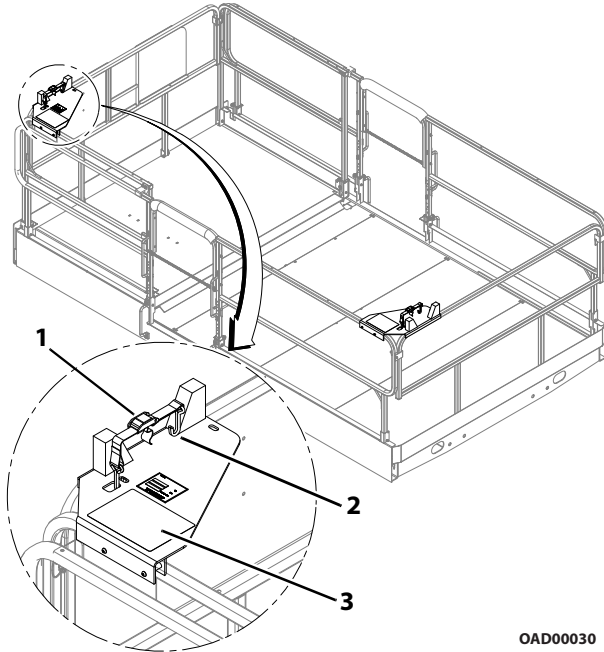

OAD00030

1. Adjustable Strap
2. Attach Hook
3. Capacity Decal

Pipe Racks store pipe or conduit inside the platform in order to prevent rail damage and optimize platform utility. It consists of two racks mounted to the top handrail with adjustable straps and hooks to secure the load in place.

#### Safety Precautions

##### **⚠ WARNING**

**THIS ACCESSORY AFFECTS OVERALL PLATFORM CAPACITY. REFER TO CAPACITY DECALS AND ADJUST ACCORDINGLY. WEIGHT IN RACKS PLUS WEIGHT IN PLATFORM MUST NOT EXCEED RATED CAPACITY.**

##### **⚠ WARNING**

**MULTIPLE MATERIAL-HANDLING ACCESSORIES MAY BE INSTALLED, BUT ONLY ONE MAY BE LOADED AT A TIME UNLESS APPROVED BY JLG INDUSTRIES, INC.**

##### **NOTICE**

**MAXIMUM LOAD IN RACKS IS 300 LB (136 KG) EVENLY DISTRIBUTED BETWEEN THE TWO RACKS. MAXIMUM LENGTH OF MATERIAL IS 20 FT (6 M). MAXIMUM DIAMETER OF MATERIAL IS 10" (254 MM).**

### **NOTICE**

#### **RETRACT PLATFORM EXTENSIONS BEFORE ATTACHING PIPE RACKS AND LOADING MATERIAL.**

- Ensure no personnel are beneath the platform.
- Do not exit platform over rails, or stand on rails.
- Do not drive machine without material secured.

#### **Preparation and Inspection**

- Ensure racks are secured to platform rails.
- Replace torn or frayed straps.
- Remove racks from platform when not in use.

#### **Operation**

1. Attach racks to platform rails.
2. Place material onto racks with weight evenly distributed between both.
3. Route the straps at each end across loaded material and attach the hooks. Tighten straps until secure.
4. To remove material, loosen straps, then carefully remove material from racks.

**NOTE:** *Reinstall straps across any remaining material before continuing machine operations.*

## 5.4 WORKSTATION

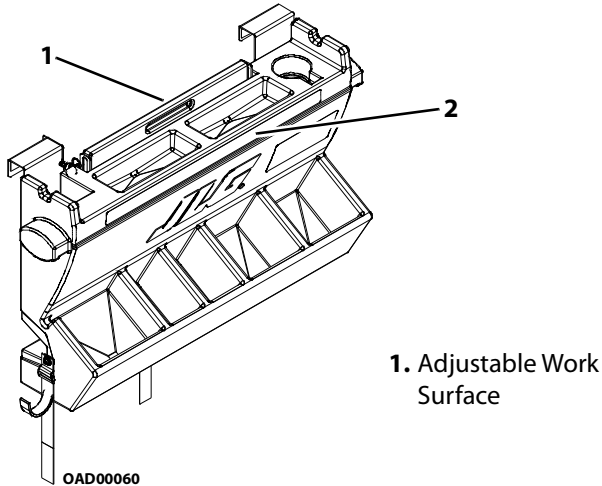

The Workstation offers an adjustable work surface and additional space for storage of tools and objects.

**NOTE:** Workstation may be attached to handrails anywhere in platform unless machine is equipped with another accessory or option. If another accessory or option is present, Workstation must be located on opposite side of platform.

## Safety Precautions

### **⚠ WARNING**

**THIS ACCESSORY AFFECTS THE PLATFORM CAPACITY. REFER TO THE CAPACITY DECAL AND ADJUST ACCORDINGLY. DO NOT OVERLOAD THE PLATFORM.**

- Return the adjustable work surface to the stowed position when finished working.
- Do not drive the machine unless materials are properly secured or stored.

## Preparation and Inspection

- Ensure the Workstation is secured to the platform.
- Check for missing or damaged components. Replace if necessary.
- Check for loose nuts and bolts. Torque to JLG Torque Chart Specifications if necessary.
- Replace any missing or illegible decals.

## Operation

To use the adjustable work surface, lift the handle and position across the Workstation.

## 5.5 LARGE MATERIAL RACKS

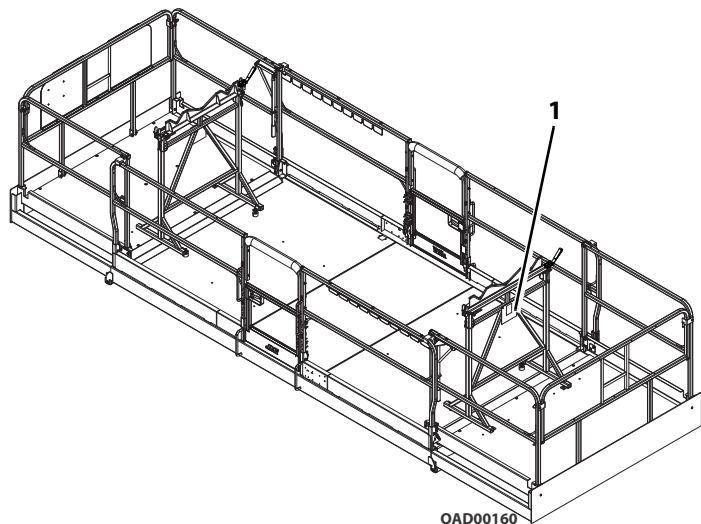

1. Capacity Decal

The Large Material Racks are mounted to the platform floor and are designed to carry flat panels or sheets and pipe/ducts. The racks may be used with both single and dual deck extensions.

## Safety Precautions

### **⚠ WARNING**

MULTIPLE MATERIAL-HANDLING ACCESSORIES MAY BE INSTALLED BUT ONLY ONE MAY BE LOADED AT A TIME UNLESS APPROVED BY JLG INDUSTRIES, INC.

### **⚠ WARNING**

THIS ACCESSORY AFFECTS THE OVERALL PLATFORM CAPACITY. REFER TO THE CAPACITY DECAL AND ADJUST ACCORDINGLY. WEIGHT IN RACKS PLUS WEIGHT IN PLATFORM MUST NOT EXCEED RATED CAPACITY.

### **NOTICE**

MAXIMUM WEIGHT OF MATERIAL ON RACKS IS 860 LB (390 KG).

### **NOTICE**

MAXIMUM RATED WIND SPEED IS 28 MPH (12.5 M/S). MAXIMUM MANUAL FORCE IS 300 LB (1335 N).

**NOTICE**

MAXIMUM DIMENSIONS FOR APPROVED MATERIAL ARE AS FOLLOWS:

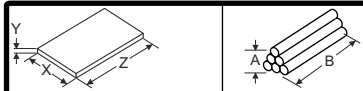

X	Y	Z	A	B
1.5m (59 in)	0.4m (16 in)	2.5m (8 ft)	0.4m (16 in)	6 m (20 ft)

- Do not drive machine without material secured.
- Do not exit the platform over the rails, or stand on the rails.

**Preparation and Inspection**

- Ensure racks are secured to the platform floor. Torque loose nuts or bolts as required.
- Check for missing or damaged components. Replace if necessary.

**Operation**

1. Position material on racks with weight evenly distributed between both racks.
2. Route the tie-down straps at each end across loaded material. Hook into place and tighten until secure.
3. To remove material, unhook tie-down straps, then carefully remove material from racks.



## **SECTION 6. GENERAL SPECIFICATIONS AND OPERATOR MAINTENANCE**

### **6.1 INTRODUCTION**

This section of the manual provides additional necessary information to the operator for proper operation and maintenance of this machine.

The maintenance portion of this section is intended as information to assist the machine operator to perform daily maintenance tasks only, and does not replace the more thorough Preventive Maintenance and Inspection Schedule included in the Service and Maintenance Manual.

#### **Other Publications Available Specific to this Machine**

Service and Maintenance Manual .....	3121708
Illustrated Parts Manual.....	3121709

### **6.2 SUPPLEMENTAL INFORMATION**

The following information is provided in accordance with the requirements of the European Machinery Directive 2006/42/EC and is only applicable to CE machines.

For electric powered machines, the equivalent continuous AWeighted sound pressure level at the work platform is less than 70dB(A).

For combustion engine powered machines, guaranteed Sound Power Level (LWA) per European Directive 2000/ 14/ EC (Noise Emission in the Environment by Equipment for Use Outdoors) based on test methods in accordance with Annex III, Part B, Method 1 and 0 of the directive, is as follows:

- 109 dB (Prior to SN E200000675)
- 106 dB (SN E200000676 to E200000900)

The vibration total value to which the hand-arm system is subjected does not exceed 2,5 m/s<sup>2</sup>. The highest root mean square value of weighted acceleration to which the whole body is subjected does not exceed 0,5 m/s<sup>2</sup>.

## SECTION 6 - GENERAL SPECIFICATIONS AND OPERATOR MAINTENANCE

### 6.3 OPERATING SPECIFICATIONS

Specification	530LRT
Maximum Occupants	6
Maximum Workload (Capacity): Main Platform: Max. on Extension (Each):	1500 lb (680 kg) 500 lb (227 kg)
Maximum Stowed Travel Grade - Gradeability (See Figure 3-6.):	40% (22°)
Maximum Stowed Travel Grade - Sideslope (See Figure 3-6.):	5°
Maximum Platform Working Height	53 ft (16.14 m)
Maximum Drive Height	32 ft (9.8 m)
Maximum Drive Speed Platform Lowered: High Mid Low (> 14 ft) Platform Elevated:	3.5 mph (5.6 kph) 2.0 mph (3.21 kph) 1.0 mph (1.61 kph) 0.5 mph (0.8 kph)
Lift Up Speed (No Load, Stowed to Full Height)	65 seconds 85-90 seconds (Dual Fuel)
Lift Down Speed (No Load, Full Height to Stowed)	60 seconds
Maximum Wind Speed	28 mph (12.5 m/s)

Specification	530LRT
Maximum Horizontal Manual Side Force: ANSI/ANSI EXPORT: CE:	300 lb force (1335 N) 90 lb force (400N)
Maximum Tire Load (Each)	5500 lb (2500 kg)
Maximum Ground Bearing Pressure	26.5 psi (1.86 kg/cm <sup>2</sup> )
Maximum Leveling Jack Bearing Pressure	70 psi (4.92 kg/cm <sup>2</sup> )
Hydraulic System Pressure Main Relief: Lift Up Relief: Steer Relief: Leveling Jacks Retract Relief:	3000 psi (207 bar) 2700 psi (186 bar) 2500 psi (193 bar) 2000 psi (138 bar)
Electrical System Voltage	12 Volt
Inside Turning Radius	103.6 in (2.63 m)
Outside Turning Radius	245 in (6.22 m)
Gross Vehicle Weight Dual Fuel/Diesel - ANSI/ANSI Export/CSA/CE w/ One Extension: w/Two Extensions: w/Mega Deck:	17,000 lb (7711 kg) 17,300 lb (7847 kg) 17,800 lb (8074 kg)
<b>NOTE:</b> Certain options or country standards increase weight.	



**Dimensional Data**

Description	Measurement
Wheelbase	117 in (297 cm)
Ground Clearance (center/platform stowed)	12 in (32 cm)
Machine Height (top of rails/platform stowed)	93 in (236.2 cm)
Machine Width	90.8 in (230 cm)
Machine Length (Leveling Jack to Leveling Jack)	192.2 in (488.3 cm)

**Capacities**

Fuel Tank	Diesel: Gasoline: LPTank:	22 gal (83.3 L) 22 gal (83.3 L) 43.5 lb (20 kg)
Hydraulic Tank		32.3 gal (122.2 L)
Engine Coolant		0.98 gal (3.7 L)

**Tires**

Size	Ply Rating	Foam Fill Tire Assembly Rating	Wheel Nut Torque
12 x 16.5 Foam Filled (Non-Marking)	10	90 psi @ 8,000 lb. (3700 kg) - Static Load	170 ft.lb. (230 Nm)
12 x 16.5 Foam Filled	10	90 psi @ 8,000 lb. (3700 kg) - Static Load	170 ft.lb. (230 Nm)
IN395/45/D20 Foam Filled (Non-Marking)	14	90 psi @ 14,740 lb. (6700 kg) - Static Load	170 ft.lb. (230 Nm)
IN395/45/D20 Foam Filled	14	90 psi @ 14,740 lb. (6700 kg) - Static Load	170 ft.lb. (230 Nm)

## SECTION 6 - GENERAL SPECIFICATIONS AND OPERATOR MAINTENANCE

### Engine Specifications

**Table 6-1. Kubota Diesel (D1305-E4B)**

Emissions	CARB, EPA Tier 4 Final, China Stage III and EU Stage V
Fuel Type:	Diesel: - Low Sulfur (<500 ppm) - Ultra Low Sulfur (15 ppm) <i>(Required to meet Stage V)</i> - up to 5% biodiesel
No. of Cylinders	3
Oil Pan Capacity	1.51 gal (5.7 L)
Engine RPM Control	Mechanical
Low RPM Set	1200 RPM
High RPM Set	2600 RPM
Alternator	60 Amp, 12V, Belt Drive
Battery	112 Amp-Hour, 950 Cold Cranking Amps, 12 VDC
Fuel Consumption:	Low RPM 0.41 gal/hr (1.5 L/hr) High RPM 2.0 gal/hr (7.6 L/hr)
Displacement	1.261 L (77 cu. in.)
Gross Power	24.8 Hp (18.5 kW) @ 2600 RPM
Gross Torque	59.1 ft. lb. (80.1 Nm) @ 1700 RPM

**Table 6-2. Kubota Diesel (D1305-E3B)**

Emissions	China Stage III and EU Stage IIIA Certification
Fuel Type:	Diesel: - Low Sulfur (<500 ppm) - Ultra Low Sulfur (15 ppm) <i>(Required to meet Stage V)</i> - up to 5% biodiesel
No. of Cylinders	3
Oil Pan Capacity	1.51 gal (5.7 L)
Engine RPM Control	Mechanical
Low RPM Set	1200 RPM
High RPM Set	3000 RPM
Alternator	60 Amp, 12V, Belt Drive
Battery	112 Amp-Hour, 950 Cold Cranking Amps, 12 VDC
Fuel Consumption:	Low RPM 0.41 gal/hr (1.5 L/hr) High RPM 2.0 gal/hr (7.6 L/hr)
Displacement	1.261 L (77 cu. in.)
Gross Power	29.1 Hp (21.7 kW) @ 3000 RPM
Gross Torque	59.1 ft. lb. (80.1 Nm) @ 2000 RPM

## SECTION 6 - GENERAL SPECIFICATIONS AND OPERATOR MAINTENANCE

**Table 6-3. Kubota Dual Fuel (WG972-GL-E4)**

Emissions	U.S. EPA Phase 3 and CARB SSI	
Fuel Type:	Gasoline - 87 Octane minimum - Ethanol/Gas Mix-10% max. - Methanol/Gas Mix-5% max. - LP (Liquid Petroleum)	
No. of Cylinders	3	
Oil Pan Capacity	0.90 gal (3.4 L)	
Engine RPM Control	Electronic - ECM	
Low RPM Set	1200 RPM	
High RPM Set	3500 RPM	
Alternator	60 Amp, 12V, Belt Drive	
Battery	112 Amp-Hour, 950 Cold Cranking Amps, 12VDC	
Fuel Consumption:	Gas -	LP -
Low RPM	0.38 gal/hr (1.45 L/hr)	2.07 lb/hr (0.94 kg/hr)
High RPM	1.76 gal/hr (6.66 L/hr)	9.77 lb/hr (4.43 kg/hr)
Displacement	58.7 cu. in. (0.962 L)	
Gross Power	Gas - 30.6 Hp (22.8 kW) @ 3500 RPM LP - 30.0 Hp (21.6 kW) @ 3500 RPM	
Gross Torque	Gas - 49.1 Ft. lb. (66.6 Nm) @ 2400 RPM LP - 48.8 Ft. lb. (66.2 Nm) @ 1800 RPM	

### Lubrication

**NOTE:** Hydraulic oils must have anti-wear qualities at least to API Service Classification GL-3, and sufficient chemical stability for mobile hydraulic system service.

**NOTE:** Aside from JLG recommendations, it is not advisable to mix oils of different brands or types, as they may not contain the same required additives or be of comparable viscosities.

## SECTION 6 - GENERAL SPECIFICATIONS AND OPERATOR MAINTENANCE

---

**Table 6-4. Lubrication Specifications**

KEY	SPECIFICATIONS
MPG	Multipurpose Grease - Having a minimum dripping point of 350°F. Excellent water resistance and adhesive qualities, and being of extreme pressure type. (Timken OK 40 pounds minimum.)
EPGL	Extreme Pressure Gear Lube (oil) - Meeting API service classification GL-5 or MIL-Spec MIL-L-2105.
EO	Engine Oil (crankcase) - See Section 6.4, Operator Maintenance, sub-section, Oil Change w/Filter (engine) and; Figure 6-2., Engine Oil Operating Specification, or; OEM Engine Manual supplied with machine
HO	Hydraulic Oil - See Section 6.4, Operator Maintenance - sub-section, Hydraulic Oil Tank and; Figure 6-1., Hydraulic Oil, Operating Temperature Specifications

## SECTION 6 - GENERAL SPECIFICATIONS AND OPERATOR MAINTENANCE

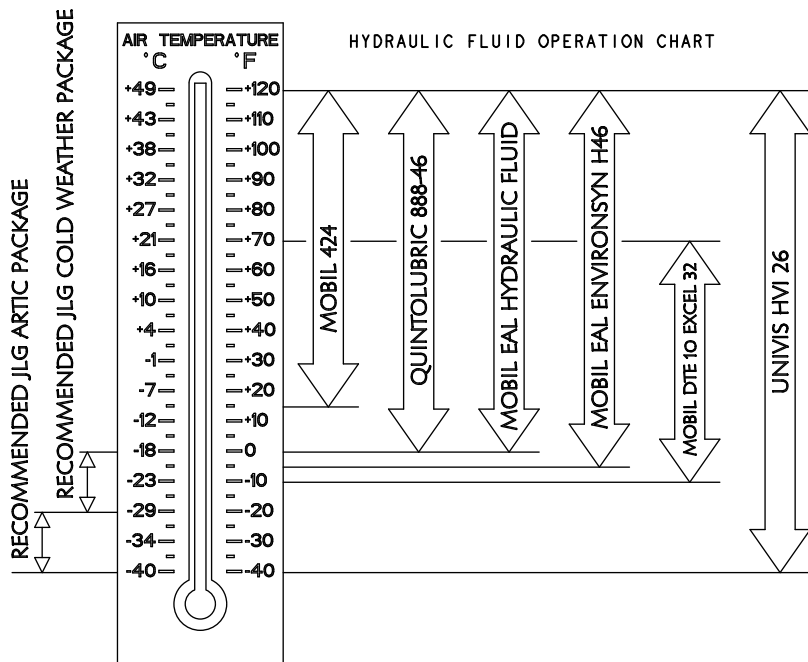

Fluid	Properties		Base			Classifications			
	Viscosity at 40°C (cSt, Typical)	Viscosity Index	Mineral Oils	Vegetable Oils	Synthetic	Synthetic Polyol Esters	Readily Biodegradable *	Virtually Non-toxic **	Fire Resistant ***
Mobilfluid 424	55	145	X						
Mobil DTE 10 Excel 32	32	164	X					X	
Univis HVI 26	26	376	X						
Mobil EAL Hydraulic Oil	47	176		X			X	X	
Mobil EAL EnviroSyn H 46	49	145			X		X	X	
Quintolubric 888-46	50	185				X	X	X	X

\* Readily biodegradable classification indicates one of the following:  
 CO2 Conversion>60% per EPA 56016-82-003  
 CO2 Conversion>80% per CEC-L-33-A-93

\*\* Virtually Non-toxic classification indicates an LC50>5000 ppm per OECD 203

\*\*\* Fire Resistant classification indicates Factory Mutual Research Corp. (FMRC) Approval

**NOTICE:**

MACHINE OPERATION USING NON-JLG APPROVED HYDRAULIC FLUIDS OR OPERATION OUTSIDE OF THE TEMPERATURE BOUNDARIES OUTLINED IN THE "HYDRAULIC FLUID OPERATION CHART" MAY RESULT IN PREMATURE WEAR OR DAMAGE TO COMPONENTS OF THE HYDRAULIC SYSTEM.

4150740\_B\_Hydraulic

**Figure 6-1. Hydraulic Oil Operating Temperature Specifications**

## SECTION 6 - GENERAL SPECIFICATIONS AND OPERATOR MAINTENANCE

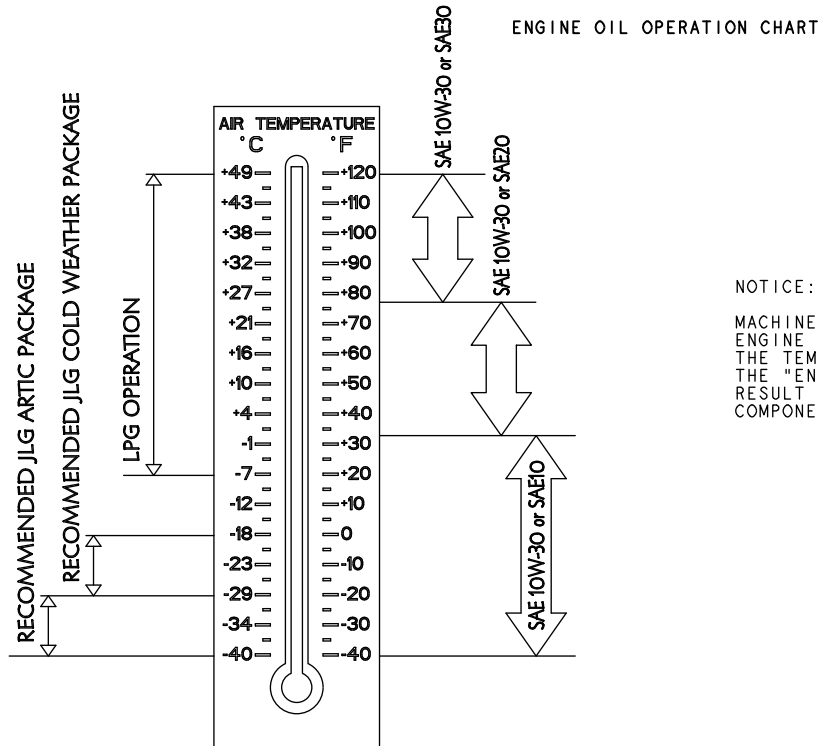

**NOTICE:**

MACHINE OPERATION USING NON-JLG APPROVED ENGINE OIL OR OPERATION OUTSIDE OF THE TEMPERATURE BOUNDARIES OUTLINED IN THE "ENGINE OIL OPERATION CHART" MAY RESULT IN PREMATURE WEAR OR DAMAGE TO COMPONENTS OF THE ENGINE.

1001204714\_A\_Dual Fuel

**Figure 6-2. Engine Oil Operating Temperature Specifications - Kubota (Dual Fuel Engine)**

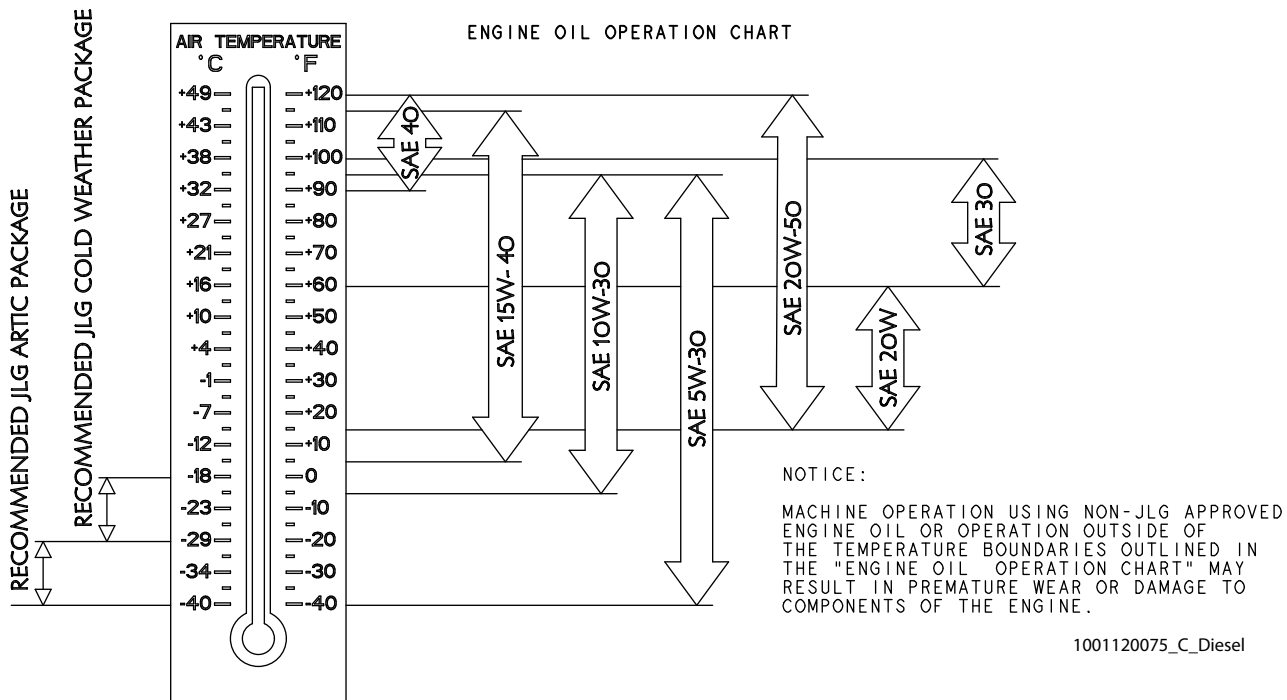

Figure 6-3. Engine Oil Operating Temperature Specifications - Kubota (Diesel Engine)

## **6.4 OPERATOR MAINTENANCE**

### **Scissor Arm Safety Prop**

**⚠ CAUTION**

**THE SAFETY PROP MUST BE USED WHENEVER MAINTENANCE PERFORMED ON THE MACHINE REQUIRES THE SCISSOR ARMS TO BE RAISED.**

1. To engage the safety prop, raise the unloaded platform high enough to allow the safety prop to rotate vertically into position. (See Figure 6-4.)
2. Rotate the rod keeper plate and release the safety prop actuator rod at the front of the machine. (See Figure 6-5.)
3. Lift the actuator rod (flat) up out of the slot in the keeper plate bracket and pull the actuator rod to align the safety props vertically with the scissor arm center pins above and below the safety prop mounting pins.
4. Set the actuator rod (flat at the set position) into the slot on the keeper plate bracket and rotate the keeper plate to lock the actuator rod in this position.
5. Lower the platform arms until the safety prop rests on the scissor arm center pin mounts above and below the safety prop.

Maintenance can now begin.

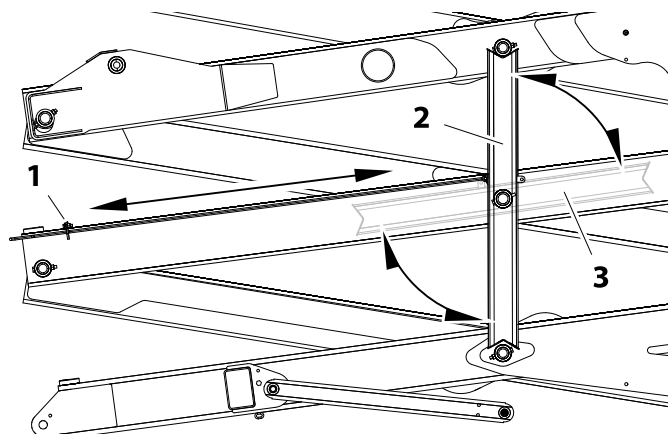

**Figure 6-4. Scissor Arm - Safety Prop Assembly**

1. Actuator Rod/Rod Keeper Plate.
2. Safety Prop in set position.
3. Safety Prop in stowed position.

To store the safety prop, raise the platform, release the actuator rod from the keeper plate bracket, push the safety prop rod so that the safety props are restored back to its stowed position. Lock the actuator rod in place with the rod keeper plate till next use.



### **⚠ WARNING**

**TO AVOID PERSONAL INJURY, USE SAFETY PROP FOR ALL MAINTENANCE REQUIRING PLATFORM TO BE ELEVATED.**

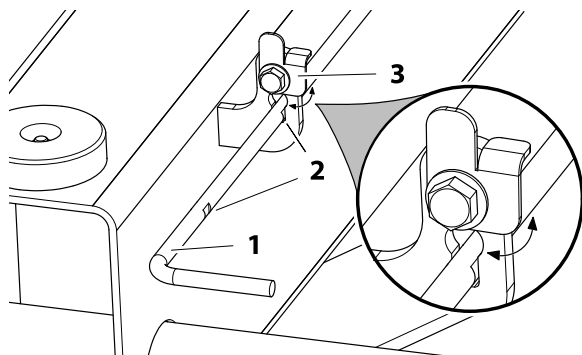

**Figure 6-5. Safety Prop Actuator Rod**

1. Safety Prop Actuator Rod
2. Notch Flats on Rod
3. Rod Keeper Plate

### **General Maintenance Tips**

**NOTE:** Be sure to lubricate like items on each side of machine.

**NOTE:** Recommended lubricating intervals are based on machine operations under normal conditions. For machines used in multi-shift operations and/or exposed to hostile environments or conditions, lubrication frequencies must be increased accordingly.

Operate hydraulic functions through one complete cycle before checking hydraulic oil level in tank. Oil should be visible in ADD sight window on hydraulic tank. If oil is not visible, add oil until oil is visible in both ADD and FULL sight windows on tank. Do not overfill tank.

Any time the pump coupling is removed, coat splines of coupling with Texaco Code 1912 grease prior to assembly.

### Operator Maintenance Components

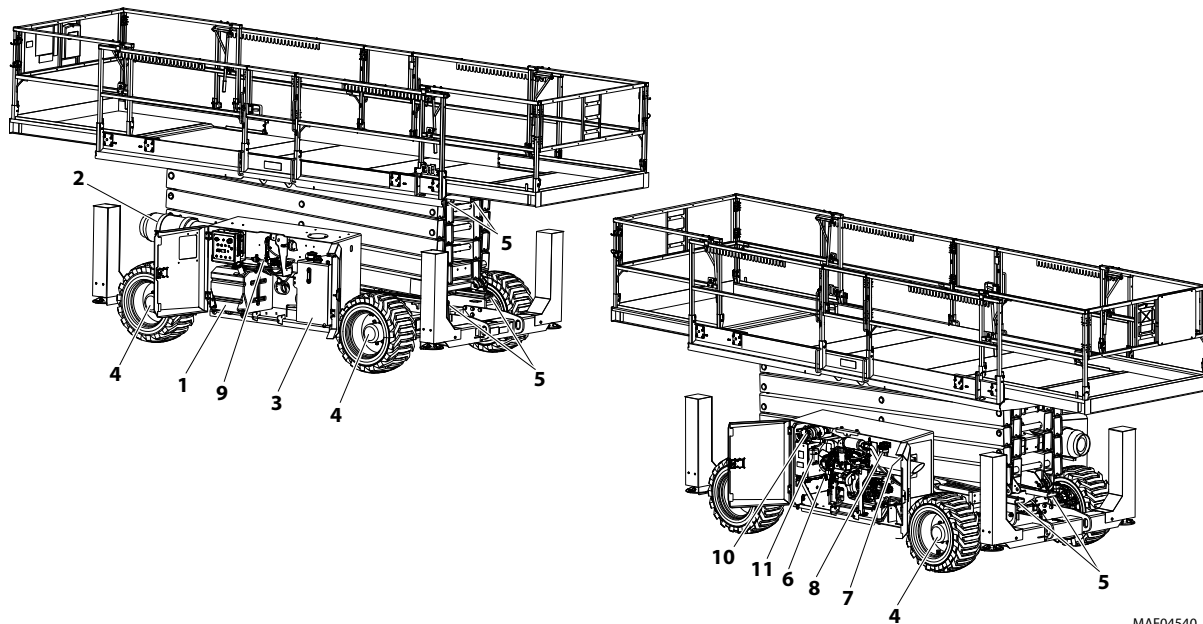

MAF04540

- 1. Fuel Tank - (Gasoline or Diesel)
- 2. Fuel Tank w/Shut-Off Valve - (LP Only)
- 3. Hydraulic Oil Tank
- 4. Drive Hubs

- 5. Scissor Arm - Sliding Wear Pads
- 6. Oil Change w/Filter - Kubota
- 7. Fuel/Water Separator Filter - Kubota- Diesel
- 8. Hydraulic Charge Filter - Kubota - Diesel

- 9. Fuel Filter/Fuel Pump - Kubota- Gasoline
- 10. Air Filter
- 11. Engine Coolant

**Fuel Tank**

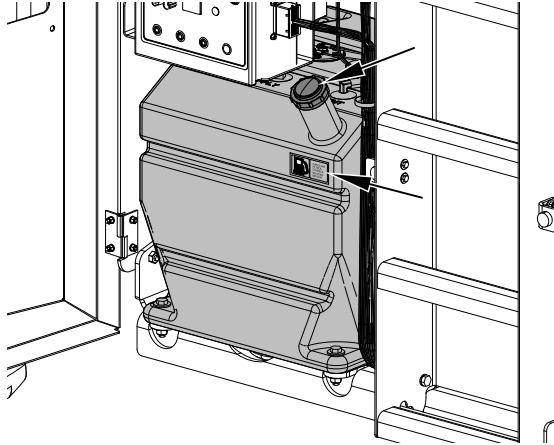

- Fuel - Diesel or Gasoline (Per Engine Type - Reference Decal on Machine)
- Capacity - 22 gal (83.2 L)

**Drive Hub**



- Lube Points - Fill Plugs (4)
- Lube - EPGL
- Interval - Every 2 years or 1200 hours

**Scissor Arms - Sliding Wear Pads**

- Lube Points - 8 Sliding Wear Pads
- Lube - MPG
- Interval - Every month or 50 hours.

### Oil Change with Filter

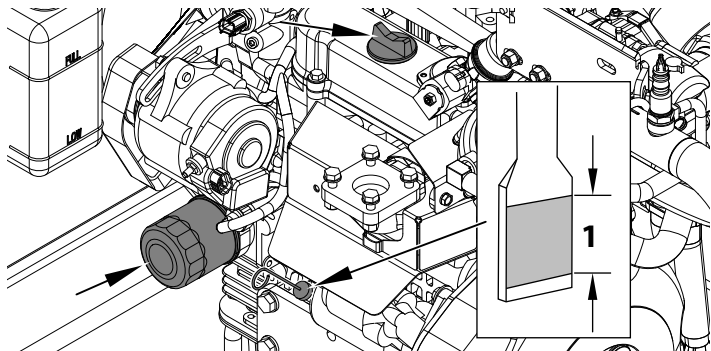

**Figure 6-6. Kubota Dual Fuel (WG972-GL-E4)**

**NOTE:** Exhaust system shown removed for illustrative purposes only.

- Lube Point(s) - Fill Cap/Spin-on Element
- Capacity - 0.9 Gal. (3.4 L) engine only
- Lube - EO - Minimum API SL (For viscosity, refer to Figure 6-2.)
- Interval - Every Year or 200 hours of operation
- Check oil level daily, maintain within marked level (1)/ Change in accordance with engine manual.

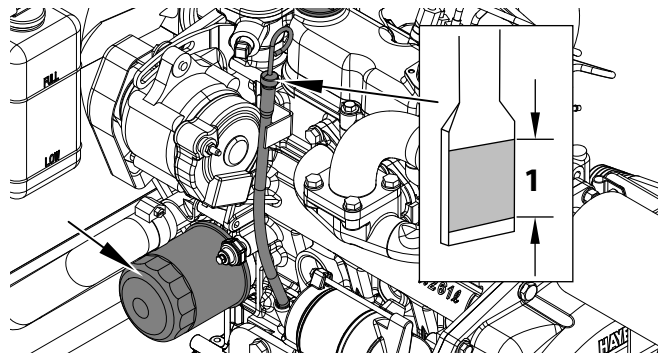

**Figure 6-7. Kubota Diesel (D1305-E3B and D1305-E4B)**

- Lube Point(s) - Fill Cap/Spin-on Element
- Capacity - 1.51 gal. (5.7 L) Engine Oil
- Lube - EO - Minimum API CF (For viscosity, refer to Figure 6-3.)
- Interval - Every Year or 200 hours of operation
- Check oil level daily, maintain within marked level (1)/ Change in accordance with engine manual.

## Hydraulic Oil Tank

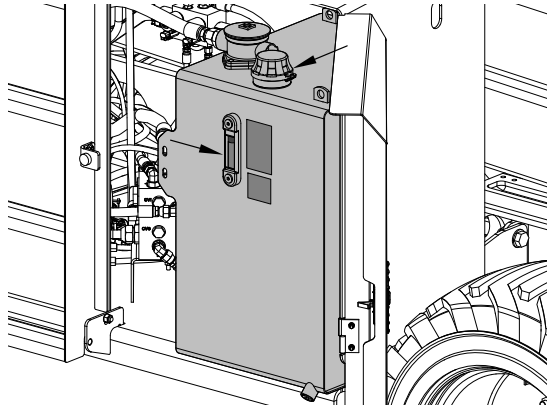

- Lube Point - Fill Cap/Fill Level
- Lube - HO - API service classification GL-3, Reference - Figure 6-1., Hydraulic Oil Operating Temperature Specifications
- Interval - Check oil every 10 hours of operation; change oil every 2 years or 1200 hours of operation.

## Fuel/Water Separator Filter (Diesel) - Kubota

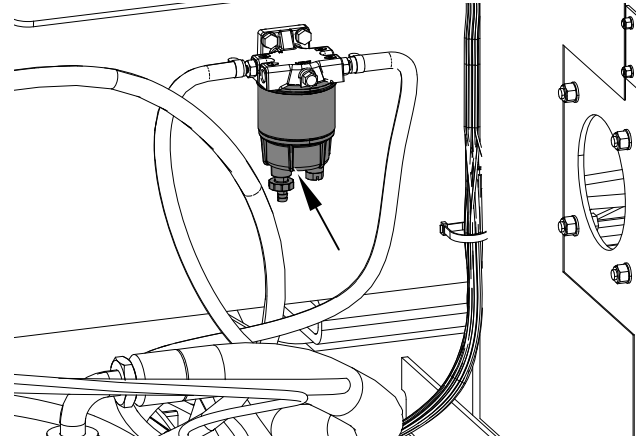

**NOTE:** Mounted inside engine cabinet on right-rear cabinet wall behind battery and exhaust pipe.

- Lube Point(s) - Replaceable Element
- Interval (Filter) - Change every 500 hours, every other oil change, or annually, whichever comes first.
- Interval (Water Bowl) - Empty Daily. Loosen drain cock on underside of fuel filter and allow all water to drain into a container until clear fuel is visible. Tighten drain.

## Hydraulic Charge Filter

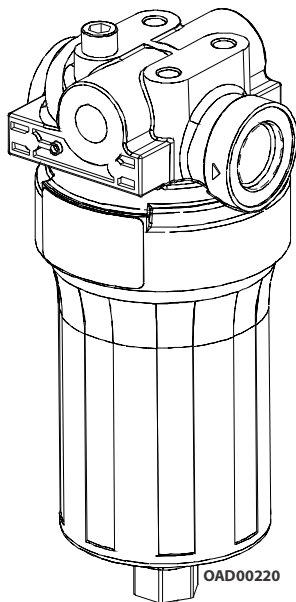

- Lube Point - Replaceable Element
- Interval - Change after first 50 hours and after every six months or 300 hours

## Fuel Strainer (Diesel) - Kubota

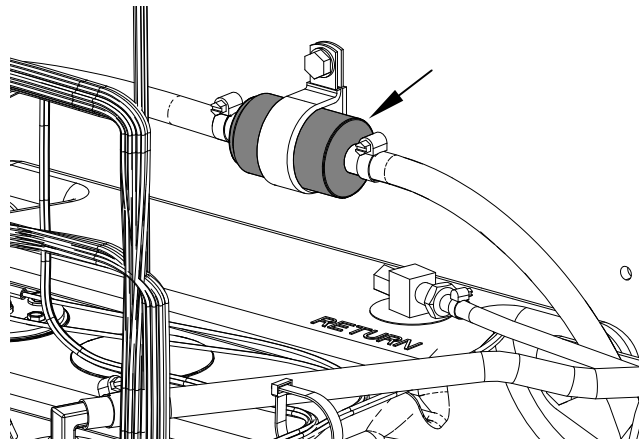

**NOTE:** Mounted inside fuel/hydraulic cabinet on left-rear cabinet wall behind fuel tank.

- Lube Point(s) - Replaceable Element
- Interval - Every Year or 600 hours of operation

**Fuel Filter (Gas) - Kubota**

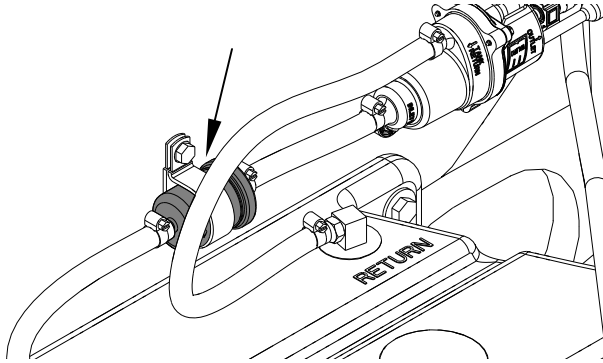

**NOTE:** Mounted inside fuel/hydraulic cabinet on left-rear cabinet wall behind fuel tank.

- Lube Point(s) - Replaceable Element
- Interval - Check every 100 hours; change every year

**Air Filter**

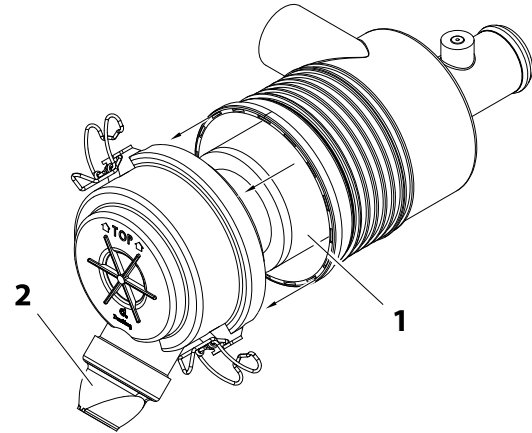

- Lube Point(s) - Replaceable Primary Filter Element (1) (Dry Type)
- Interval - Every 6 months or 300 hours of operation. Under severe operating conditions (such as a very dusty work area) check condition of filter more often.
- Once a week, squeeze the evacuator valve (2) on bottom of air cleaner assembly to allow collected debris to fall out of the air cleaner.

### Engine Coolant

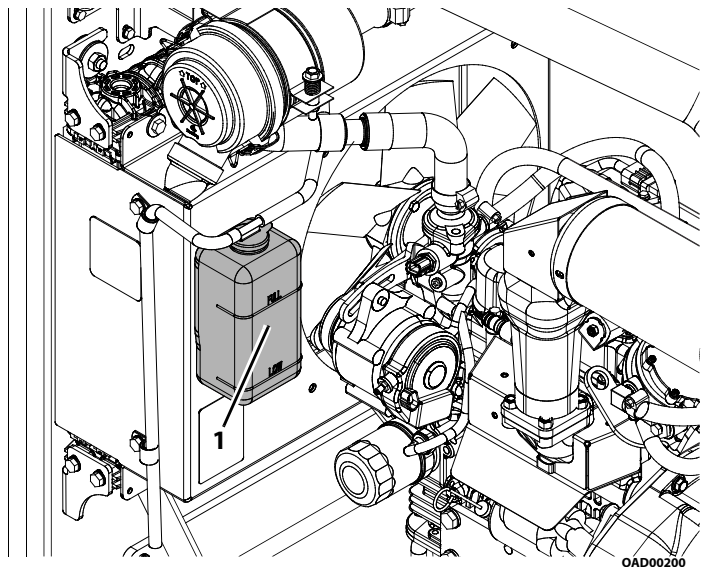

- Lube Point - Fill Cap/Fill Level
- Interval - Check coolant level daily. Ensure it is between the "FULL" and "LOW" lines (1). If coolant level is low, allow fluid to cool, then add as required.

### 6.5 PROPANE FUEL SYSTEM PRESSURE RELIEF

#### **⚠ CAUTION**

THE PROPANE FUEL SYSTEM OPERATES AT PRESSURES UP TO 312 PSI (21.5 BAR). TO MINIMIZE THE RISK OF FIRE AND PERSONAL INJURY, RELIEVE THE PROPANE FUEL SYSTEM PRESSURE (WHERE APPLICABLE) BEFORE SERVICING THE PROPANE FUEL SYSTEM COMPONENTS.

To relieve propane fuel system pressure:

1. Close the manual shut-off valve on the propane fuel tank.
2. Start and run the vehicle until the engine stalls.
3. Turn the ignition switch OFF.

#### **⚠ CAUTION**

RESIDUAL VAPOR PRESSURE WILL BE PRESENT IN THE FUEL SYSTEM. ENSURE THE WORK AREA IS WELL VENTILATED BEFORE DISCONNECTING ANY FUEL LINE.



### 6.6 PROPANE FUEL SYSTEM LEAK TEST



**NEVER USE AN OPEN FLAME OF ANY TYPE TO CHECK FOR PROPANE FUEL SYSTEM LEAKS.**

Always inspect the propane fuel system for leaks after performing service. Check for leaks at the fittings of the serviced or replaced component. Use a commercially available liquid leak detector or an electronic leak detector. When using both methods, use the electronic leak detector first to avoid contamination by the liquid leak detector.

### 6.7 TIRES AND WHEELS

#### Tire Damage

For pneumatic tires, JLG Industries, Inc. recommends that when any cut, rip, or tear is discovered that exposes sidewall or tread area cords in the tire, measures must be taken to remove the JLG product from service immediately. Arrangements must be made for replacement of the tire or tire assembly.

For polyurethane foam filled tires, JLG Industries, Inc. recommends that when any of the following are discovered, measures must be taken to remove the JLG product from

service immediately and arrangements must be made for replacement of the tire or tire assembly:

- A smooth, even cut through the cord plies which exceeds 3 in (7.5 cm) in total length.
- Any tears or rips (ragged edges) in the cord plies which exceeds 2.5cm (1 in) in any direction.
- Any punctures which exceed 2.5cm (1 in) in diameter.
- Any damage to the bead area cords of the tire.

If a tire is damaged but is within the above noted criteria, the tire must be inspected on a daily basis to ensure the damage has not propagated beyond the allowable criteria.

#### Tire Replacement

JLG recommends a replacement tire be the same size, ply and brand as originally installed on the machine. Please refer to the JLG Parts Manual for the part number of the approved tire for a particular machine and model. If not using a JLG approved replacement tire, we recommend that replacement tire have the following characteristics:

- Equal or greater ply/load rating and size of original
- Tire tread contact width equal or greater than original
- Wheel diameter, width, and offset dimensions equal to the original.
- Approved for application by the tire manufacturer (Including inflation pressure and maximum tire load).

## **SECTION 6 - GENERAL SPECIFICATIONS AND OPERATOR MAINTENANCE**

---

Unless specifically approved by JLG Industries Inc. do not replace a foam filled tire assembly with a pneumatic tire. When selecting and installing a replacement tire, ensure that all are inflated to the pressure recommended by JLG. Due to size variations between tire brands, both on the same axle should be the same.

### **Wheel Replacement**

The rims installed on each product model have been designed for stability requirements which consist of track width, tire pressure, and load capacity. Size changes such as rim width, center piece location, larger or smaller diameter, etc., without written factory recommendations, may result in an unsafe condition regarding stability.

### **Wheel Installation**

It is extremely important to apply and maintain proper wheel mounting torque.

#### **WARNING**

**WHEEL NUTS MUST BE INSTALLED AND MAINTAINED AT THE PROPER TORQUE TO PREVENT LOOSE WHEELS, BROKEN STUDS, AND POSSIBLE DANGEROUS SEPARATION OF WHEEL FROM THE AXLE. BE SURE TO USE ONLY THE NUTS MATCHED TO THE CONE ANGLE OF THE WHEEL.**

Tighten the lug nuts to the proper torque to prevent wheels from coming loose. Use a torque wrench to tighten the fasteners. If you do not have a torque wrench, tighten the fasteners with a lug wrench, then immediately have a service garage or dealer tighten the lug nuts to the proper torque. Over-tightening will result in breaking the studs or permanently deforming the mounting stud holes in the wheels. The proper procedure for attaching wheels is as follows:

## SECTION 6 - GENERAL SPECIFICATIONS AND OPERATOR MAINTENANCE

1. Start all nuts by hand to prevent cross threading. DO NOT use a lubricant on threads or nuts.
2. Tighten nuts in the following sequence:

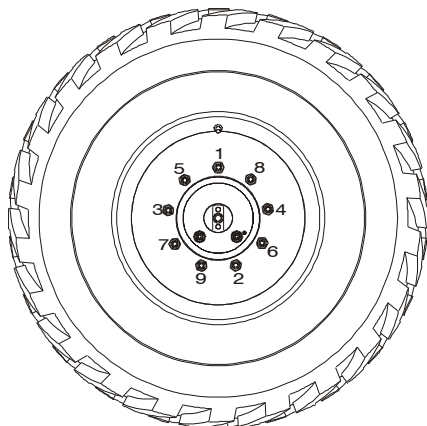

9 LUG PATTERN

3. The tightening of the nuts should be done in stages. Following the recommended sequence, tighten the nuts per wheel torque chart.

Wheel nuts should be torqued after the first 50 hours of operation and after each wheel removal. Check torque every 3 months or 150 hours of operation.

**Table 6-5. Wheel Torque Chart**

TORQUE SEQUENCE (DRY)		
1st Stage	2nd Stage	3rd Stage
40-50 ft lbs (60-70 Nm)	90-105 ft lbs (125-150 Nm)	170 ft lbs (230 Nm)

### 6.8 DECAL INSTALLATION

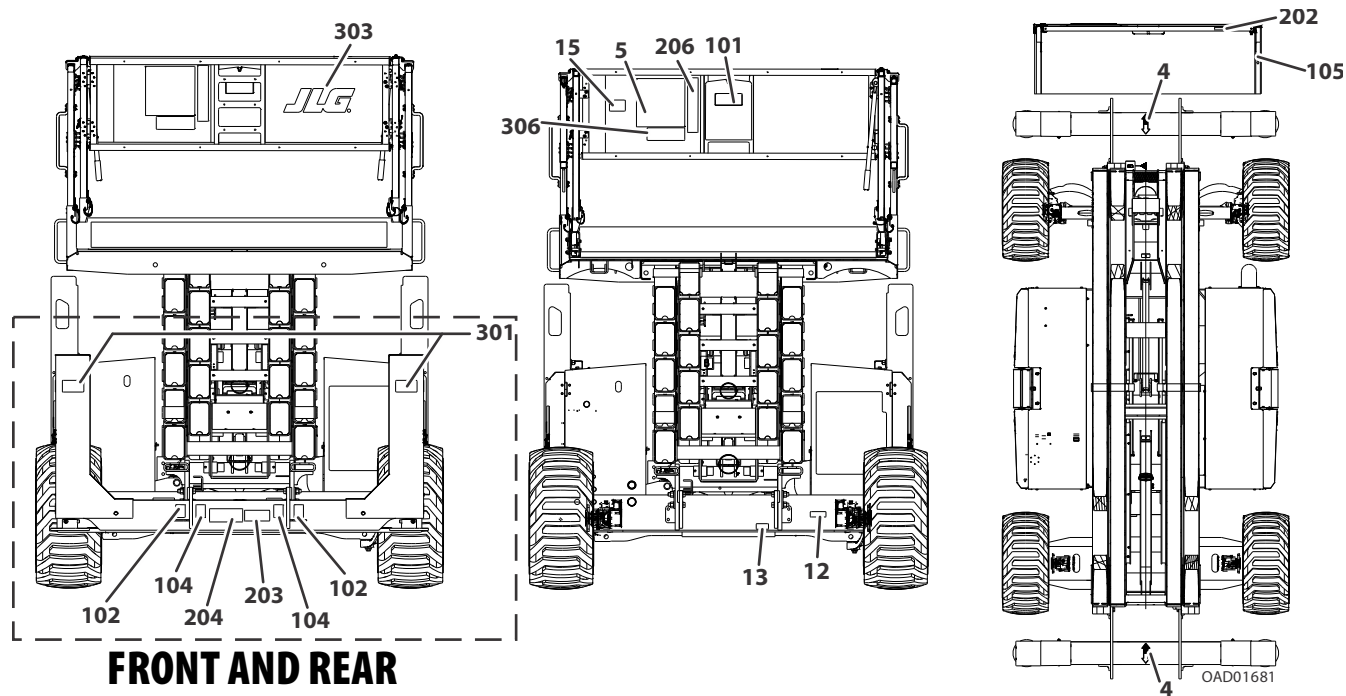

## SECTION 6 - GENERAL SPECIFICATIONS AND OPERATOR MAINTENANCE

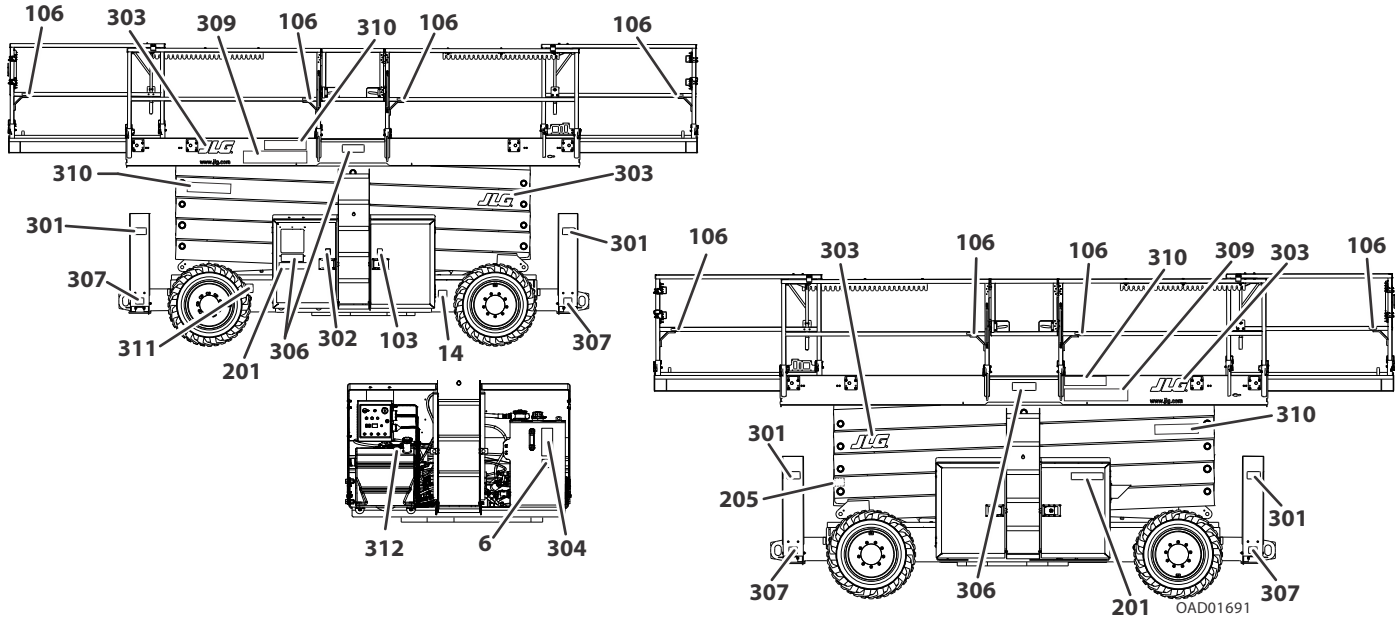

**SECTION 6 - GENERAL SPECIFICATIONS AND OPERATOR MAINTENANCE**

**Table 6-6. Decal Location Legend - ANSI, ANSI Export**

<b>Item #</b>	<b>English - ANSI (1001187668-D)</b>	<b>French/CSA (1001187669-D)</b>	<b>Eng/Chinese (1001187671-C)</b>	<b>Eng/Spanish (1001187672-C)</b>	<b>Portuguese/Spa (1001187673-C)</b>	<b>English/Korean (1001215449-C)</b>
1-2	--	--	--	--	--	--
3	1702631	1702631	1702631	1702631	1702631	1702631
4	1703687	1703687	1703687	1703687	1703687	1703687
5	1703816	1704684	1705195	1704691	1704699	1001162115
6	1704412	1704412	1704412	1704412	1704412	1704412
7-11	--	--	--	--	--	--
12	--	1705303	--	--	--	--
13	1001223453	1001223453	--	--	--	--
14	1001223055	1001223971	1001224050	1001224049	1001224052	1001224048
15	1001231801	--	--	--	--	--
100	--	--	--	--	--	--
101	1701509	1701509	1701509	1701509	1701509	1701509
102	1703811	1703811	1703811	1703811	1703811	1703811
103	1703812	1703812	1703812	1703812	1703812	1703812
104	1703814	1703814	1703814	1703814	1703814	1703814
105	1703819	1703819	1703819	1703819	1703819	1703819
106	1704277	1704277	1704277	1704277	1704277	1704277
200	--	--	--	--	--	--
201	1703818	1704686	1705193	1704693	1704701	1001162111

**SECTION 6 - GENERAL SPECIFICATIONS AND OPERATOR MAINTENANCE**

**Table 6-6. Decal Location Legend - ANSI, ANSI Export**

<b>Item #</b>	<b>English - ANSI (1001187668-D)</b>	<b>French/CSA (1001187669-D)</b>	<b>Eng/Chinese (1001187671-C)</b>	<b>Eng/Spanish (1001187672-C)</b>	<b>Portuguese/Spa (1001187673-C)</b>	<b>English/Korean (1001215449-C)</b>
202	1703821	1704687	1705194	1704694	1704702	1001162112
203	1703823	1705040	1705944	1705041	1705043	1001162114
204	1704432	1705311	1705943	1705316	1705318	1001162113
205	1705019	1705019	1705019	1705019	1705019	1705019
206	1001192853	1001203075	1001203078	1001203076	1001203077	1001162113
301	1701214	1704690	1001207839	1704697	1704698	1001215447
302	1701505 - Diesel 1701542 - Dual Fuel	1701505 - Diesel 1701542 - Dual Fuel	1701505 - Diesel 1701542 - Dual Fuel	1701505 - Diesel 1701542 - Dual Fuel	1701505 - Diesel 1701542 - Dual Fuel	1701505 - Diesel 1701542 - Dual Fuel
303	--	--	--	--	--	--
304	1702788 1704174 - SYN	1702788 1704174 - SYN	--	--	--	1702788 1704174 - SYN
305	--	--	--	--	--	--
306	1001202973 - Single Ext. 1001191732 - Dual Ext.	1001202973 - Single Ext. 1001191732 - Dual Ext.	1001202973 - Single Ext. 1001191732 - Dual Ext.	1001202973 - Single Ext. 1001191732 - Dual Ext.	1001202973 - Single Ext. 1001191732 - Dual Ext.	1001202973 - Single Ext. 1001191732 - Dual Ext.
307	1001191735	1001191735	1001191735	1001191735	1001191735	1001191735
309	1001142595	1001142595	1001142595	1001142595	1001142595	1001142595
310	1001200543	1001200543	1001200543	1001200543	1001200543	1001200543
311	1700818	1704271	1001207840	1702720	1001207841	1700818
312	1001125387	1001125387	--	--	--	1001125387

## SECTION 6 - GENERAL SPECIFICATIONS AND OPERATOR MAINTENANCE

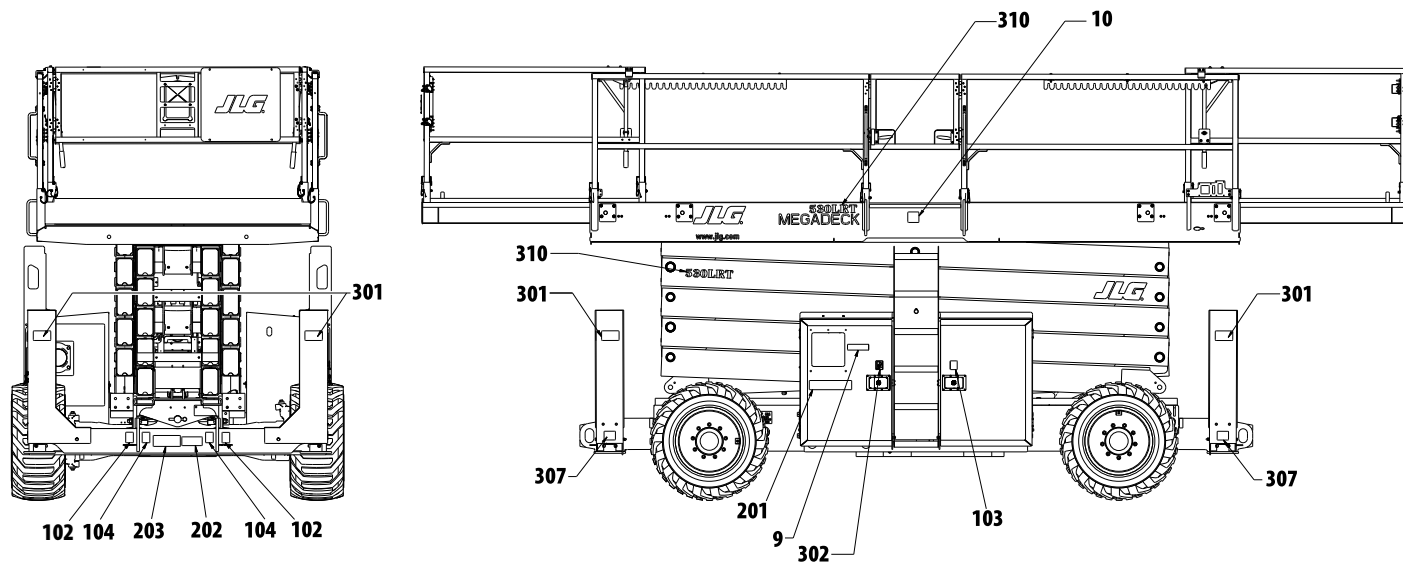

Figure 6-8. Decal Location - Sheet 1 of 4 (CE/AUS/JPN)



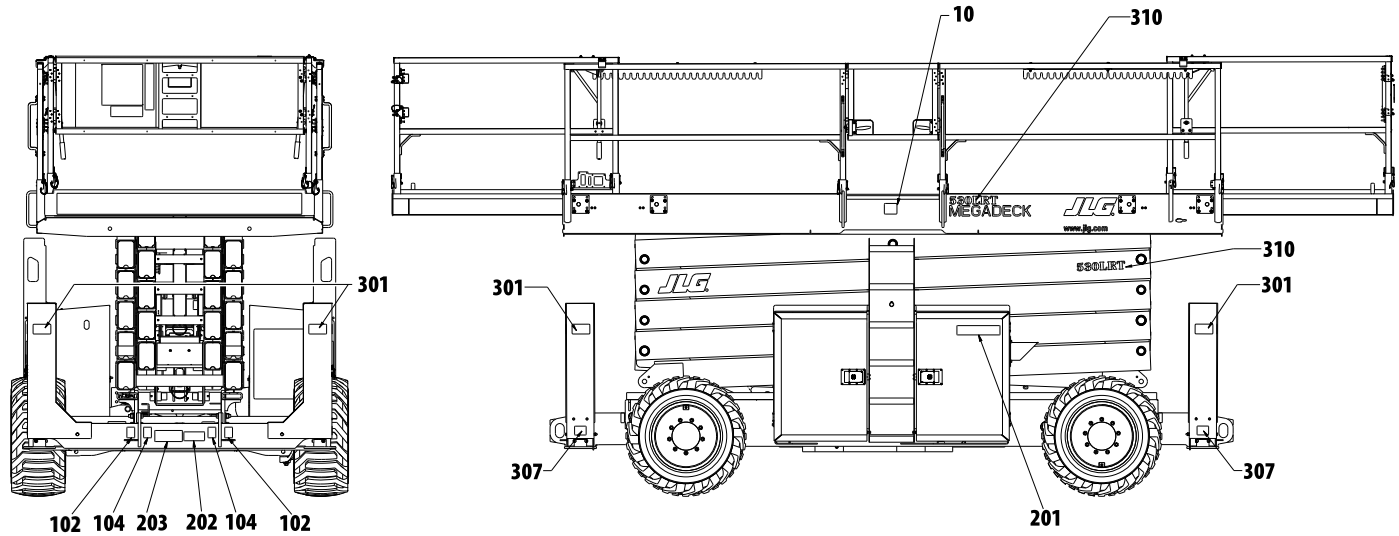

Figure 6-9. Decal Location - Sheet 2 of 4 (CE/AUS/JPN)

## SECTION 6 - GENERAL SPECIFICATIONS AND OPERATOR MAINTENANCE

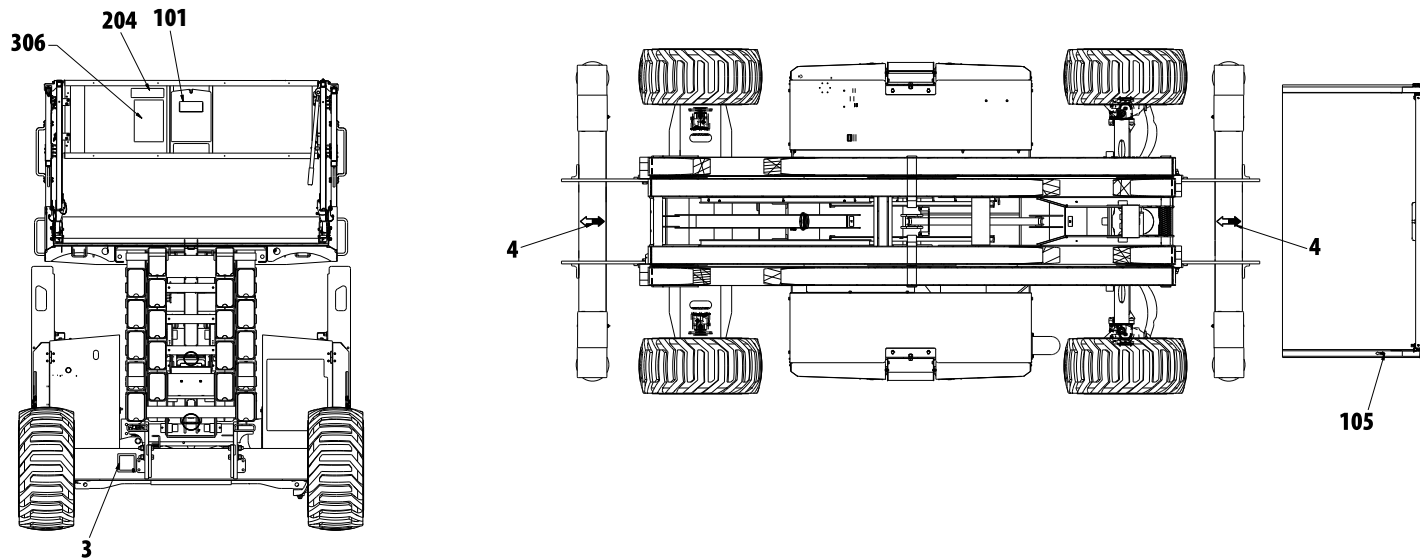
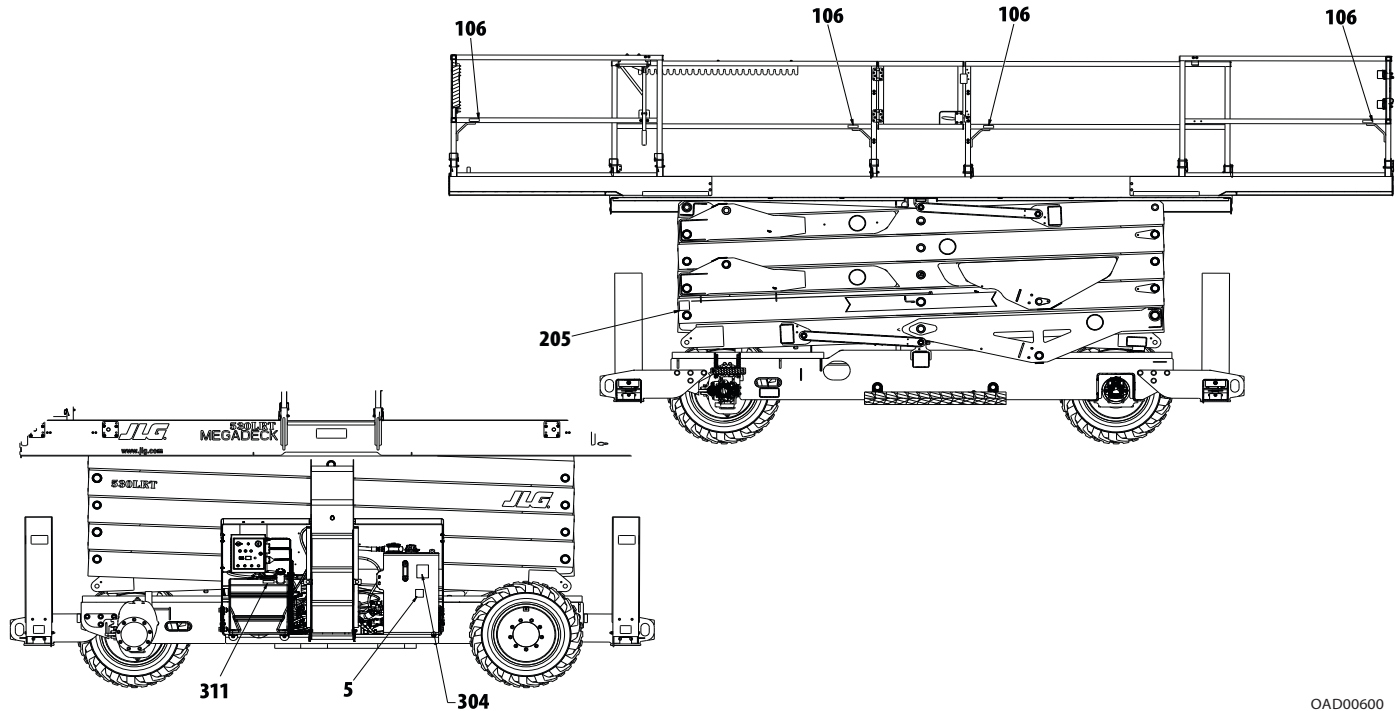

Figure 6-10. Decal Location - Sheet 3 of 4 (CE/AUS/JPN)

## SECTION 6 - GENERAL SPECIFICATIONS AND OPERATOR MAINTENANCE



OAD00600

Figure 6-11. Decal Location - Sheet 4 of 4 (CE/AUS/JPN)

**SECTION 6 - GENERAL SPECIFICATIONS AND OPERATOR MAINTENANCE**

**Table 6-7. Decal Legend - CE/AUS/JPN**

Item #	CE/AUS/JPN (1001187670-E)
1-2	--
3	1702631
4	1703687
5	1704412
6-8	--
9	1001197634
10	1705515 (Prior to E200000675) 80463053 (SNE200000676 to E200000900)
100	--
101	1701509
102	1703811
103	1703812
104	1703814
105	1703819
106	1704277
200	--
201	1705019

**Table 6-7. Decal Legend - CE/AUS/JPN**

Item #	CE/AUS/JPN (1001187670-E)
202	1705372
203	1705671
204	1706338
301	1701785
302	1701505
303	--
18-304	1702788 1704174 - SYN 1703479 - German 1704175 - SYN - German
305	--
306	1001202974 - Single Ext. 1001191733 - Dual Ext.
307	1001191735
309	--
310	1001200543
311	1001139654









An Oshkosh Corporation Company

**Corporate Office**  
**JLG Industries, Inc.**  
**1 JLG Drive**

**McConnellsburg, PA 17233-9533 USA**

**☎ (717) 485-5161 (Corporate)**

**☎ (877) 554-5438 (Customer Support)**

**📠 (717) 485-6417**

**Visit our website for JLG Worldwide Locations.**  
**[www.jlg.com](http://www.jlg.com)**