

LAVINA
by  **SUPERABRASIVE**

ELITE
S E R I E S

LAVINA ELITE L25GE

User Manual





Warranty Registration Card

Complete and submit this form within 30 days from the date of purchase. The registration is invalid without the machine serial number.

Section 1: Customer Information

Customer name

Address

City

State and Zip Code

Phone #

Email

Section 2: Machine Information

LAVINA model

Serial #

Purchase Date

Purchased From (distributor, dealer)

*Email: warranty@superabrasive.us / Fax: 706-658-0357
Superabrasive Inc., 9411 Jackson Trail Rd, Hoschton, GA 30548*

WARRANTY AND RETURNS

WARRANTY POLICY FOR LAVINA® E MACHINES

A warranty card must be submitted to Superabrasive within 30 days of purchase in order for the foregoing warranty to apply.

You can either mail a hard copy of the warranty card or submit it electronically - see page 2.

Superabrasive warrants, from the time of delivery and receipt by the original customer, new and unused products sold by Superabrasive or Superabrasive-appointed distributors or dealers. Goods shall be free from defects in materials and workmanship. Superabrasive or a Superabrasive-appointed repair facility shall either replace or repair any defects in the Goods resulting from faulty design, materials, or workmanship. Products repaired or replaced during the warranty period shall be covered by the foregoing warranty for the remainder of the original warranty period, or ninety (90) days from date of the repair or shipment of the replacement, whichever is longer. Spare parts for repair will be either new or equivalent to new.

Warranty period shall be 2 years from the time of delivery and receipt by the original customer, or 600 operating hours on the machine - whichever occurs first. Superabrasive will cover the shipping charges for the transportation of the machine to Superabrasive (or an approved repair facility) and back to the customer (within the contiguous 48 United States) in the event that the damage occurs and is reported within 200 operating hours. Shipping charges, if covered by Superabrasive, must be agreed upon in advance and approved by Superabrasive. Thereafter, the customer will have to cover the shipping charges to Superabrasive and back. Superabrasive will not warranty Goods after a period of 2 years from the time of delivery and receipt by the original customer, or 600 operating hours on the machine - whichever occurs first.

Superabrasive shall not be liable for any defects that are caused by circumstances that occur after the Goods have been delivered and whilst the Goods are in the possession of the purchaser. Furthermore, the warranty does not include normal wear and tear or deterioration. Wear parts are not warranted. Superabrasive is not liable for defects arising out of use of non-OEM parts.

The Warranty is void if the purchaser has not followed the maintenance plan stipulated by the machine's manual and warranty card. The warranty is void if the purchaser repairs said Goods himself, or if repairs are conducted by a repair facility that is not approved by Superabrasive. Superabrasive's liability does not cover defects which are caused by faulty maintenance, incorrect operation, faulty repair by the purchaser, or by alterations conducted without Superabrasive's prior written consent. The same applies to any alterations of the Goods or services performed by another party other than Superabrasive, a Superabrasive-appointed distributor, or a Superabrasive-approved repair facility. The warranty is not applicable on a defect that arises due to tools or parts that are not original to Superabrasive. Replaced defective parts shall be placed at Superabrasive's disposal and shall become property of Superabrasive. If such defective parts are replaced

within the warranty period, the shipping charges will be covered by Superabrasive. In warranty complaint cases, when no defects are found for which Superabrasive is liable, Superabrasive shall be entitled to compensation for the labor, material cost, and shipping charges, incurred by Superabrasive as a result of the complaint.

The warranty herein is non-transferable, and only applies to the original owner or purchaser of the machine.

RETURN POLICY FOR LAVINA® E MACHINES

The Lavina® E machines may be returned, subject to the following terms:

In no case, a machine is to be returned to Superabrasive Inc. for credit or repair without prior authorization. Please contact Superabrasive Inc. or your local distributor for an authorization and issuance of a return authorization number. This number along with the serial number of the machine must be included on all packages and correspondence. Machines returned without prior authorization will remain property of the sender and Superabrasive Inc. will not be responsible for them. No machines will be credited after 90 days from the date of invoice.

All returns must be shipped freight prepaid. Returned machines may be exchanged for other equipment or parts of equal dollar value. If machines are not exchanged, they are subject to a fifteen percent (15%) restocking fee.

LAVINA ELITE L25GE	1	7.MAINTENANCE AND INSPECTION	21
1. GENERAL INFORMATION	5	REMARK.....	21
MANUFACTURER.....	5	MECHANICAL PARTS.....	21
GENERAL DESCRIPTION.....	5	CLEANING.....	21
MACHINE CHARACTERISTICS.....	5	CHECK HOURLY.....	21
LAVINA® 25GE MAIN DESIGN.....	5	CHECK DAILY.....	21
ENVIRONMENTAL CONDITIONS.....	5	CHECK AND REPLACE AFTER THE FIRST 8 WORKING HOURS.....	21
VACUUM CONNECTION.....	6	CHECK AND REPLACE EVERY 50 WORKING HOURS.....	21
TECHNICAL DATA.....	6	CHECK AND REPLACE EVERY 200 WORKING HOURS.....	21
2. SAFETY INSTRUCTIONS	7	CHECK AND REPLACE EVERY 400 WORKING HOURS.....	22
PREPARATION FOR WORK.....	7	VACUUM.....	22
PROTECTION DEVICES.....	7	WATER LEAKS.....	22
ARREST FUNCTIONS.....	7	MECHANICAL PARTS.....	22
SAFE USE.....	7	8. TROUBLESHOOTING	23
FIRE SAFETY.....	7	8.1 ENGINE.....	23
EMISSIONS.....	7	8.2 CHECKING AND CHANGING OIL.....	24
HAZARD COMMUNICATION.....	7	8.2 CHECKING AND CHANGING OIL.....	24
LOCAL AGENCIES AND REGULATIONS.....	8	8.4 SEPARATING THE HEAD FROM THE CARRIAGE.....	25
RESIDUAL RISKS.....	8	8.4 DISMOUNTING/MOUNTING THE ENGINE.....	29
BEFORE YOU BEGIN.....	8	8.6 REPLACING THE CLUTCH.....	29
OPERATING MACHINE.....	8	8.7DISMOUNTING TOOL HOLDER TO CHANGING V-RINGS AND FELT- RINGS.....	30
AFTER WORK IS COMPLETED.....	9	8.8 CORRECTING DEFLECTION OF THE USED PLANETARY CHAIN.....	32
THE WORK AREA.....	9	8.9 MOUNTING NEW PLANETARY CHAIN.....	32
PERSONAL PROTECTIVE EQUIPMENT (PPE).....	9	8.10 REPLACING THE PLANETARY DRIVING CHAIN WHEEL AND PLANETARY TENSIONER.....	33
TESTING.....	9	8.11 TENSIONING AND REPLACING THE BELTS.....	34
OPERATOR.....	9	8.12 REPLACING THE PLANETARY DRIVEN CHAIN WHEEL.....	36
PROPANE CYLINDERS.....	9	8.13 REPLACING THE PULLEY UNITS.....	36
REFUELLING CYLINDERS.....	10	8.14 REPLACING THE PLANETARY UNIT.....	37
STORAGE CYLINDERS.....	10	9. DISPOSAL	37
TRANSPORTING CYLINDERS.....	10	10. MANUFACTURER'S CONTACTS	37
3. HANDLING AND TRANSPORTATION	11	11.EMISSION CONTROL WARRANTY STATEMEN	38
ADJUSTING THE HANDLE.....	11	12. SPARE PARTS	40
LIFTING THE MACHINE FROM WORKING TO TOOL MOUNTING POSITION.....	12	ASSEMBLY AND PARTS SPECIFICATIONS.....	40
LIFTING.....	12	1. LAVINA® 25GE GENERAL PARTS.....	40
STORAGE.....	12	2. LAVINA® 25GE BUMPER.....	40
4. OPERATION	13	3. LAVINA® 25GE CONTROL BOARD.....	41
PRELIMINARY CONTROLS.....	13	4. LAVINA® 25GE CONTROL BOARD WITH THROTTLE CABLE.....	41
FUEL-MINDER USER MANUAL.....	13	5. LAVINA® 25GE CARRIAGE.....	ERROR! BOOKMARK NOT DEFINED.
SYSTEM COMPONENTS.....	13	6. LAVINA® 25GE WATER PUMP.....	44
OVERVIEW OF FEATURES.....	13	7. LAVINA® 25GE WATER BALL VALVE.....	44
FAULTY O2 SENSOR DETECTION.....	13	8. LAVINA® 25GE WATER PUMP REGULATOR.....	44
BUILT-IN FUEL LOCKOFF CONTROLLER.....	13	9. LAVINA® 25GE WATER TANK.....	45
EMISSIONS WARNINGS AND SHUTDOWN.....	13	10. LAVINA® 25GE WATER INSTALLATION.....	45
DUAL HOUR METERS.....	13	11. LAVINA® 25GE ENGINE BASE PARTS.....	46
BATTERY VOLTMETER.....	14	12. LAVINA®25GE GARD ASSEMBLY.....	46
ENGINE TACHOMETER.....	14	13. LAVINA®25GE TOP COVER.....	ERROR! BOOKMARK NOT DEFINED.
JOB TIMER.....	14	14. LAVINA®25GE TOP COVER ASSEMBLY.....	47
PASSWORD PROTECTION.....	14	15. LAVINA® 25GE BOTTOM COVER 1 PARTS.....	48
SERVICE ALERTS.....	14	16. LAVINA® 25GE PLANETARY DRIVE PARTS.....	49
SLEEP MODE.....	14	16.1. LAVINA® 25GE PULLEY UNIT ASSEMBLY.....	50
MAIN MENU NAVIGATION AND USE.....	14	17. LAVINA® 25GE BOTTOM COVER 2 PARTS.....	50
MAIN MENU.....	14	18. LAVINA®25GE TOOL HOLDER PARTS/SEE ALSO FIG.8.7.13/.....	51
LED ALERTS & RESETTNG SERVICE INTERVALS.....	15	(P0S.1 INCLUDE P0S.1.1;1.2;1.3/P0S.1.3 INCLUDE P0S.1.3.1 AND ETC.)... 51	
OPTIONS MENU NAVIGATION AND USE.....	15	LAVINA® 25GE KAWASAKI Fx600V ENGINE PARTS.....	51
OPTIONS MENU.....	15		
SAFETY INFORMATION.....	15		
WATER FLOW CONTROL SYSTEM.....	16		
ADJUSTING AND MOUNTING TOOLS.....	17		
VACUUM CONNECTION.....	17		
USE HORIZONTAL PROPANE TANK.....	18		
CONTROL BOARD.....	18		
THE CONTROL BOARD.....	18		
STARTING THE MACHINE.....	18		
OPERATING THE MACHINE.....	18		
STOPPING THE MACHINE.....	19		
5. TOOLS AND ACCESSORIES	19		
TOOL HOLDER KEY.....	19		
SECURITY PLATE FOR QUICKCHANGE PADS.....	19		
6. POPULAR TOOLS	20		

1. GENERAL INFORMATION

This owner's manual is intended for the operator of the Lavina® E machine, the servicing technician as well as for anyone involved with operating or servicing the machine. We recommend that you read the instructions very carefully and follow them strictly. The manual includes information about assembling, using, handling, adjusting and maintaining your Lavina® X floor grinding and polishing machine.

MANUFACTURER

Superabrasive was founded in 1987, as a manufacturer of high quality diamond tools for the stone and concrete industry. Today, Superabrasive is one of the world's leading companies in the production of diamond tools and floor grinding machinery. At Superabrasive, we strive to deliver the very best solutions to our customers, and enable them to work more efficiently.

GENERAL DESCRIPTION

The Lavina® E machine is intended for grinding, polishing and buffing concrete, marble, granite, limestone and terrazzo surfaces with diamond tools. Additionally, the machine could be used for grinding wood floor surfaces.

The Lavina® E machine is a three-disc machine, which can be used wet or dry.

For best results, use only tools manufactured or recommended by Superabrasive and its distributors.

⚠ WARNING The Lavina® E machine is manufactured and fitted for the above-mentioned applications only! Every other use may possess risks to the persons involved.

MACHINE CHARACTERISTICS

The Lavina® E machine is made of two main component sections:

LAVINA® 25GE MAIN DESIGN

- **The two main components** are the carriage and main head.

The handle on the frame is adjustable in height and allows the operator to work in a correct and safe posture.

- **The LED lights** (Fig.1.1;Fig.1.2) enables the operator to work in darker areas.

⚠ WARNING Existing lighting system does not replace adequate overhead lighting.

- **The propane tank** is placed on a tank holder on the backside of the frame.
- **The control panel** (fig.1.3) is positioned on top of the frame and contains switching devices, which ensure the proper functioning of the engine, LPG supply turning on/off of the electromagnetic connector/clutch.
- **The water tank** is on the opposite side of the frame, so that the weight of the water does not affect the operation of the machine. The frame weight, on the other hand, is fully absorbed by the driving wheels. An electric pump sprays the water through a front mist system or internal under cover.
- **The Engine Kawasaki FX600V** with electric clutch is mounted on the base plate and it is driving the three heads with a belt system.
- **The planetary motion** derives from the main engine, driven by a simplex roller chain,
- **The self-leveling Guard** is designed to have contact with the surface. Anytime, no matter the height of the tool used.
- **"Quickchange" tool holder** is designed to hold the tools with "Quickchange" connection.

ENVIRONMENTAL CONDITIONS

The temperature range for operating the Lavina® E machine outdoors is between 41°F and 86°F or 5°C and 30°C. Never use the Lavina® E machine during rain or snow when working outdoors. When working indoors, always operate the machine in well-ventilated areas.



Figure 1.1



Figure 1.2



Figure 1.3

VACUUM CONNECTION

A connection for a vacuum dust extractor is located on the carriage. The Lavina® E machine does not include a vacuum dust extractor. The customer must purchase the vacuum dust extractor separately. The vacuum dust extractor must be adapted for floor grinders and have a minimum air displacement of 310m³/h with a negative vacuum of 21 kPa.

TECHNICAL DATA

TECHNICAL DATA	Lavina® 25GE	
engine	Kawasaki FX600V	
Capacity of engine	603cc	36.8cu.in
Power	14.2kW /3600 min	19 hp/3600 min
Tool holder rpm	570-1030 rpm	
Direction off rotation	The heads have counter-clockwise / left rotation	
Engine rpm	2000-3600 rpm	
Working width	655 mm	25"
Tool holder diameter	3 x 225 mm	3 x 9"
Weight	346kg	764 lbs
Grinding pressure Weights upward	189 kg	418 lbs
Grinding pressure Weights downward	226 kg	499 lbs
Application	wet and dry	
Vacuum hose port	Cam lock E250	Cam lock E250
Water tank capacity	20 l	5.2 gal
Water feed	Peripheral and front mist with pump	
Capacity Propane tank	9kg	20lbs
Machine LxWxH	1852x705x1214 mm	72.9"x27,8"x47.8"
Packing crate LxWxH	1480x840x1454 mm	58.3"x33.1"x57.2"

VIBRATIONS

The vibrations of the machine are within the limits of directives and harmonized standards from the European Union when the Lavina® E is operated with the recommended tools and in normal conditions.

SONOROUS EMISSIONS

The sonorous emissions are within the limits of directives and harmonized standards from the European Union when the Lavina® E is operated with the recommended tools and in normal conditions. However, as previously stated, the operator must wear ear protectors.

LABEL DATA

The data on the label provides the correct Voltage and kW (needed for operational purposes);

Weight (needed for transportation purposes); production year and serial number (needed for maintenance purposes).

CUSTOMER SERVICE

For customer assistance and technical support call your local distributor or call Superabrasive Inc. at 1-800-987-8403 or visit us at: www.superabrasive.com , where you can download a copy of this manual.

2. SAFETY INSTRUCTIONS

RECOMMENDED USE

The LAVINA® 25GE machine is designed and manufactured to grind and polish concrete, terrazzo and natural stone floors. It can be used for renovations as well as for polishing.

The machine is designed for dry or wet use. When using it dry, use a vacuum of appropriate size. For more information, please refer to the chapter on handling the vacuum connection.

PROHIBITED



WARNING

USE

The machine MUST NOT be used:

- For applications different from the ones stated in the General Description chapter.
 - In environments which:
 - Possess risks of explosion
 - Possess high concentration of powders or oil substances in the air
- Possess risks of fire
- Feature inclement conditions.
- Possess electromagnetic radiation.
- In nursing homes, hospitals, day-care centers, etc
- In areas where loose tiles or other objects are preventing proper use of the machine.
- In rooms without proper ventilation
 - In nursing homes, hospitals, day-care centers, etc
 - In areas where loose tiles or other objects are preventing proper use of the machine.
 - In rooms without proper ventilation

PREPARATION FOR WORK



WARNING

Make sure that:

- The work area is closed so that no person unfamiliar with operating the machine can enter the area
- The tool plate and tools are mounted on the machine properly
- There are no missing parts of the machine
- The machine is in upright working position
- The protection devices are working properly.

PROTECTION DEVICES



WARNING

- The machine is equipped with several protection devices including the following:
 - A protection skirt and a hood for protecting the tool plates.
 - These devices protect the operator and/or others persons from potential injuries. Do not remove them. On contrary, before using the machine, please ensure that all protection devices are mounted and function properly.
 - The Envirogard Emissions Monitoring System

ARREST FUNCTIONS



WARNING

- Functions of arresting of the machine are following:
 - Switch to stop the engine
 - Button to stop the grinding movement
 - Close the propane tank

SAFE USE



WARNING

The LAVINA® 25GE is designed to reduce all risks correlated with its use. However, it is not possible to fully eliminate the risks of an accident with the machine. Unskilled or uninstructed operator may cause correlated residual risks. Such risks are:

- Position Risks due to operator's incorrect working position
- Entanglement Risks due to wearing inappropriate working clothes
- Training Risks due to lack of operational training

PROPANE SAFETY



WARNING

- Propane is a flammable gas whose vapors are heavier than air. As is the case with gasoline, propane can explode if the proper cautions are not heeded. Propane is odorized with an agent having a distinct odor that is recognizable at very low concentrations. This helps in identifying leaks, even when they are small.
 - Awareness and basic safety precautions are required when working with propane. As long as these precautions are followed, risk is negligible. Ignorance, however, could pose needless risk.
 - The two greatest hazards with propane powered floor care machines are:
 - **Carbon Monoxide Poisoning:** This is the most frequently reported incident associated with propane powered floor care machines and is caused by excessive exhaust emissions. The symptoms are headache, dizziness and nausea. A major cause involves engines with poor preventive maintenance practices, usually those with dirty air filters and machines operated in confined areas without adequate ventilation. Another cause may be substandard, inexpensive machines with no emissions control technology and improperly set carburetion.
 - **Overfilled Fuel Cylinders:** Nearly all fire related incidents reported result from bringing a cylinder into a building without first checking for overfill. This action is dangerous, unwise, and unnecessary.

FIRE SAFETY



WARNING

- Be aware of the potential dangers of fire or explosion when using propane, and take normal fire-safety precautions.
 - Fire:** There is a possibility of fire from LPG vapor leaking or venting from fuel cylinders or carburetion equipment.
 - Explosion:** LPG vapor concentrated or confined to a small, restricted space may explode or ignite.
 - Propane** may experience a **BLEVE**, a boiling liquid expanding vapor explosion.

EMISSIONS



WARNING

- All propane powered floor care machines produce emissions. Most are harmless, but some are dangerous and can be fatal. Carbon monoxide (CO) poses the greatest risk, since CO can be lethal within as little as 30 minutes exposure at 3,000 parts per million (ppm) concentration.
 - Carbon monoxide is an invisible, odorless, colorless gas created when fossil fuels (such as gasoline, wood, coal, propane, oil and methane) burn incompletely.

HAZARD COMMUNICATION



WARNING

- A **Material Safety Data Sheet** for propane shall be posted in all buildings where propane will be used.

Because propane is odorized, it is easily detected at levels of just a few parts per million, which is much less than the exposure limit of 1000 parts per million.

If you smell propane while operating a propane floor care machine, do the following:

Stop the engine:

1. Pull the throttle to the stop position (if present) or turn the key switch to the off position.
2. Shut off the service valve on the propane cylinder.
3. Move the floor machine to a well-ventilated area.
4. Remove the cylinder from the machine and take it outside the building.
5. If the cylinder is leaking, contact a DOT approved repair shop to determine the cause of the leak and have the shop, not you, repair it.

If a fire occurs while the machine is being operated, do the following:

1. Stop the engine: pull the throttle to the stop position (if present) or turn the key switch to the off position.
2. Shut off the service valve on the propane cylinder if possible. Be careful not to be burned.
3. Move the machine outside if possible. If not possible, move it to a well-ventilated area away from flammable materials.
4. Do not attempt to extinguish the flame from a gas leak. If you do, the gas will build up in the area and could re-ignite. Starve the fire by shutting off the supply of gas.
5. HAVE THE MACHINE AND CYLINDER INSPECTED BEFORE USING THEM AGAIN

LOCAL AGENCIES AND REGULATIONS

- **NFPA**

Operating a propane powered floor care machine requires compliance with certain safety regulations. The National Fire Protection Agency (NFPA) Standard for Storage and Handling of LP Gas is the appropriate authority for safe propane use. A copy of this publication is available through the NFPA in Quincy, MA (1-800-334-3555).

Among its regulations, NFPA #58 requires that all personnel employed in the handling of propane gas be trained in its proper handling and operating procedures. It also requires them to carry a written certification from their employer or training supervisor to attest to such training. Although this is directed mainly to those who fill and transport liquid propane gas, Onyx Environmental Solutions recommends that operators of propane powered floor care machines in public places be trained and certified as well.

With regard to operation of propane powered floor care equipment, even though NFPA 58 8-4.5 says “these machines shall be permitted to be used in buildings frequented by the public, including the times when such buildings are occupied by the public,” Onyx Environmental Solutions suggests usage when occupancy of a given work area is minimal.

- **CARB / EPA**

The California Air Resource Board (CARB) and Environmental Protection Agency (EPA) also set limits for propane-powered

engines used outdoors, but CARB/EPA approval does not signify that the engine is safe to use indoors.

- **CGA**

The Canadian Gas Association (CGA) has set a limit of 1500 ppm CO in exhaust flow.

- **OSHA**

For propane powered machines used indoors, the Occupational Health and Safety Administration (OSHA) has established a limit of 50 ppm CO for 8-hour time weighted average (TWA) in ambient air and is considering a limit of 800 ppm CO in exhaust flow.

- **DOT**

The Department of Transportation (DOT) has established regulations regarding the safety of fuel cylinders including the ones used on propane powered floor care machines.

- **Local Agencies**

Local law enforcement agencies such as the local Fire Marshall also rely on independent testing labs such as UL and CGA before giving their approval of the use of some equipment. These labs thoroughly test equipment and submit their stamp of approval only after rigorous testing. While not being required by all law enforcement agencies, the stamp of approval by these agencies further assures the operator that he or she is working with and around safe equipment.

NOTE: In order to reduce all consequences of the above- mentioned risks, we advise that machine operators will follow the instructions in the manual at all times.

RESIDUAL RISKS

- During the normal operating and maintenance cycles, the operator is exposed to few residual risks, which cannot be eliminated due to the nature of the operations.

BEFORE YOU BEGIN

- Clear working area of any debris or objects.
- A first-time operator must always read the manual and pay attention to all safety instructions.
- All propane connections and cables must be inspected for potential damages.
- Perform general daily inspections of the machine and inspect the machine before each use.
- Always inspect the safety devices:
 - The tool protector must be working
 - Mount the security disc when working with Quickchange Pads.
 - The machine must be clean
 - Never operate the machine in the rain!
 - Confirm that there are no missing parts especially after transportation, repair or maintenance.
- Before filling the water tank with water, make sure the machine is not running and the main switch is turned off.
- Before turning on the machine, make sure that the base is placed on the floor, the machine MUST NOT be in a tilted position when starting

OPERATING MACHINE

- When operating the Lavina® 20G-X, make certain that there is no one, but you around the machine.
- Never leave the machine unattended while working.
- The water hose must move freely and must be damage-free.



WARNING



WARNING



WARNING

- Make sure the working surface is not too uneven. If it is, it may damage the machine.

AFTER WORK IS COMPLETED

Clean the machine and its surroundings properly

- Empty and clean the water tank
- Store the machine in a safe place
- Place the Propane bottle outside in designated storage

The Work Area

- Prevent people or vehicles from entering the work area.
- Clear all hoses and cables from the work area.
- Always check the floor for debris

PERSONAL PROTECTIVE EQUIPMENT (PPE)

- Always wear safety shoes when working with the machine.
- Always wear ear protectors when working with the machine.
- All personnel in the immediate work area must wear safety glasses with side shields.
- Always wear safety gloves when changing the tools.
- Always wear clothes suitable for the work environment.
- Always wear Carbon Monoxide Indicator badges as an extra precaution.
- The plastic indicator contains a colored indicator button that darkens in the presence of Carbon Monoxide. The relative darkness of the indicator button indicates the level of CO in the ambient atmosphere. Most indicator badges have a useful life of 30 days, depending on the concentration of contaminants, humidity, and temperature.

TESTING

- There are a great number of instruments offered on the market to test for toxic gases. Only those designed to read carbon monoxide resulting from combustion engines are considered acceptable for testing exhaust emissions from propane powered floor machines.
- Some instruments are used to read “ambient air” and may be damaged if used to take readings in the muffler or tail pipe. Selecting the proper instrument is an important part of meeting the testing requirements.
- Generally speaking, units capable of reading in ppm, (parts per million), at ranges from 0 to 1000 are adequate for checking ambient air (air in the breathing zone of the operator). Instruments capable of testing carbon monoxide in the exhaust should be able to read from 0 to at least 2000 ppm and should be certified by the manufacturer for that purpose.
- Some instruments and systems used for these purposes are:

1) **AMBIENT AIR MONITORING**

DRAGER Model 190: Manufactured by National Drager.

SENSIDYNE gas sampling system with YB-11038 Sensidyne detector tubes

DRAGER gas sampling system with YB-4620 Drager detective tubes

GAS-TECH Model CO-95

ENERAC POCKET 60: Manufactured by Energy

**WARNING****WARNING****WARNING****WARNING**

Efficiency System

2) ENGINE EXHAUST

ANALYZERS HORIBA GAS

ANALYZER

ENERAC 2000 COMBUSTION ANALYZER

ENERAC POCKET 60

3) DATA LOGGERS

INDUSTRIAL SCIENTIFIC CORP. MODEL STX-70

CO MONITOR, Data-Logger

BIOSYSTEMS INC. “TEXILOG” Data-Logger

- All instruments used for testing must be calibrated at intervals recommended by the manufacturer. The monitor, model number and date of calibration will be recorded with all test results.

OPERATOR**WARNING**

- The operator must know the machine’s work environment.
- Only one operator can work with the machine at a time.
- The operator must be properly trained and well instructed prior operating the machine.
- The operator must understand all the instructions in this manual.
- The operator must understand and be able to interpret all the drawings and designs in manual.
- The operator must know all sanitation and safety regulations pertaining to the operation of
- The operator must have floor grinding experience.
- The operator must know what to do in case of emergency.
- The operator must have adequate technical knowledge and preparation.
- The operator is expected to operate their equipment safely and responsibly. They are responsible for the proper handling and storage of propane cylinders, identifying potential hazards associated with his job and avoiding these hazards at all times.

PROPANE CYLINDERS**WARNING**

- The Propane cylinders are constructed of either aluminum or steel. We recommend aluminum because it is lighter and guards against rusting. The cylinder used on propane powered floor machines is classified as a 4E240 cylinder. Its rated capacity is 20 lbs. and this designation refers to the model of the cylinder. Actual propane capacity achieved during filling can be less than, equal to, or slightly more than 20 lbs. Use only UL, CTC/DOT listed cylinders.
- The propane cylinder used on the floor machine is a motor fuel cylinder as listed by the Department of Transportation. Unlike the common 20-lb propane outdoor grill cylinders (which are not legal for use on propane floor machines), the motor fuel cylinder has a number of safety systems designed into it to ensure your safety at all times.
- There are two types of 20 lb. motor fuel cylinders.
 - Liquid draw
 - Vapor draw

- The liquid draw cylinder is used on larger vehicles like forklifts. These machines have special vaporizing carburetors to allow the propane to change from a liquid to a gas before being burned in the combustion chamber.
- The vapor draw cylinder is used on small machines like the propane powered floor care machines. The vacuum generated by the engine draws up  **WARNING** through the fuel system. The propane powered floor care machine does not have an evaporating system and will freeze up if liquid propane is introduced to it. It is necessary that special attention be paid to ensure that neither the liquid nor the vapor draw cylinders be overfilled.

REFUELLING CYLINDERS

- The proper filling of propane cylinders is a subject so important that it warrants special attention. Propane cylinders should only be filled by qualified propane dealers.
- Most important, propane cylinders should be filled no more than 80% of their rated capacity. The other 20%, which is about 4" (10 cm) from the top of the cylinder, is called the vapor space or headspace. This vapor can be compressed without causing the pressure relief valve to open and vent gas to the area around the cylinder. If there is no headspace to allow for fuel expansion, the pressure relief valve will open, releasing propane gas into the atmosphere. This is a very dangerous and volatile situation as there is always the possibility that enough of the vented gas could find its way down to the floor and come in contact with a pilot light from a furnace, hot water heater, or other source of ignition.

Propane changes into a gas, is -44°F (-42° C). Exposing unprotected skin to propane gas or liquid could result in frostbite injury.

- All new cylinders should be vented and purged of air per manufacturer's instructions before use. Never bleed propane cylinders indoors.

STORAGE CYLINDERS



- When not in use, propane cylinders always should be stored outside in an upright position in a secure,

tamperproof, steel mesh storage cabinet. This cabinet may be located next to the building but with at least five feet (1.5 m) of space between the cabinet and the nearest building opening (door or window), also away from heat and direct sunlight.

- Do not install the cabinet near a stairway or street elevator as vented propane gas will seek a lower level since it is heavier than air and could find its way into the basement of the building. Do not store cylinders full or empty inside a building or inside a vehicle. Although it is unlikely that propane will vent from a stored cylinder, if it should, the vapor could come in contact with an ignition source such as a spark from a power tool or other appliance and create a flash fire.
- Do not smoke or use a device with an open flame when handling or transporting propane cylinders.

TRANSPORTING CYLINDERS



- When transporting cylinders to a propane dealer or to a job, make sure the cylinders are securely fastened and standing in an upright position with the service valve closed.
- A cylinder rattling around in the back of a vehicle and banging into other objects constitutes a hazard. Avoid dropping or banging cylinders against sharp objects.
- The propane cylinders are sturdily constructed but a series of hard jolts could cause damage.
- Please note that any cylinder that has been filled is always considered full, no matter how little propane gas remains in it. This is because even when all liquid has evaporated into vapor there is still some propane gas vapor left in the cylinder. Because this remaining fuel is flammable, an empty cylinder should be treated with the same careful procedures as one that is filled to the 80% level with liquid propane. The only time that a cylinder is considered empty is when it is new, before it has been filled with propane.
- When transporting a propane powered floor machine, the propane cylinder may be strapped onto the machine as long as the machine itself is firmly secured in the vehicle.
- Of course, spare cylinders should always be secured in an upright position.

3. HANDLING AND TRANSPORTATION

ADJUSTING THE HANDLE

The Handle on the frame is adjustable in height and allows the operator to work in a correct and safe posture (Fig. 3.1, Fig. 3.2, Fig. 3.3, Fig. 3.5). Choose the upright position to move easy the machine .

The machine has two built in weights. Each one could stay in upward Fig.3.5 or downward position Fig.3.6. You can lock and secure the weight in each of the two positions.

/Fig.3.7;Fig.3.8/.



Figure 3.1



Figure 3.2



Figure 3.3



Figure 3.4



Figure 3.5



Figure 3.6



Figure 3.7

Figure 3.8

LIFTING THE MACHINE FROM WORKING TO TOOL MOUNTING POSITION

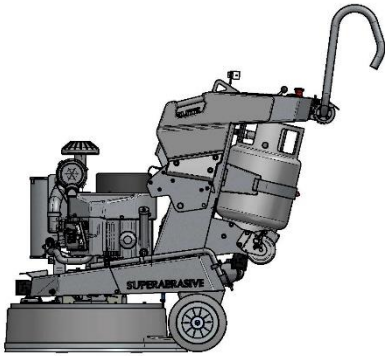

Figure 3.9

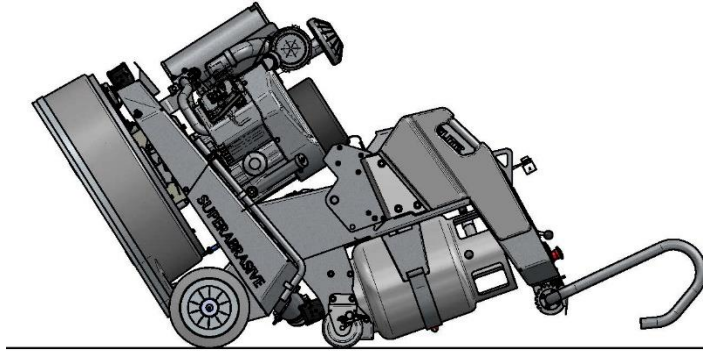

Figure 3.10

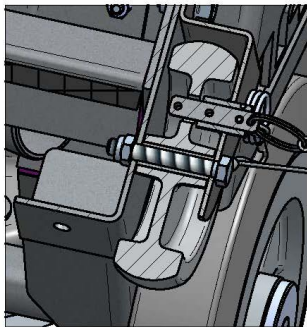

Figure 3.11

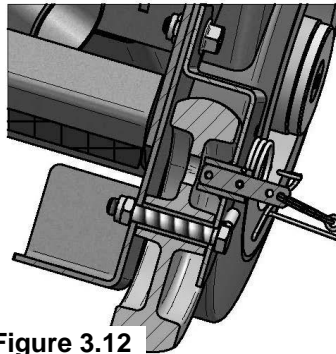

Figure 3.12

Lock the weights in upward position. Put the handles of the carriage as shown on (Fig. 3.9). Ensure that the water tank is empty before flipping the machine. Push the handles and flip in position shown on (Fig. 3.10). If necessary, help by placing your foot on the heel near the gas bottle. Always keep both rear wheels locked (Fig. 3.11). Unlock the wheels (Fig. 3.12) only when you wish to move the machine

LIFTING

Lifting the machine by crane is possible by using the handles of the carriage (see fig. 3.13). Do not lift any other loads on the machine. Always use hoisting equipment rated for 350 kg (772 lbs) or greater.

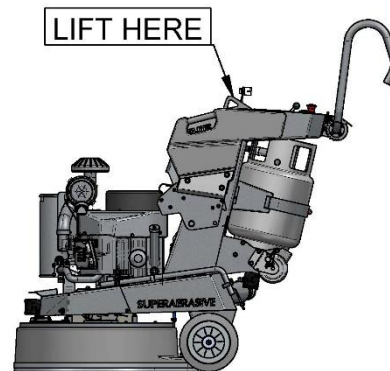

Figure 3.13

STORAGE

Always store the LAVINA® E machine in a dry place. Never transport the LAVINA® E machine unprotected; it may be damaged if transported unprotected and exposed to rain or snow.

⚠ WARNING When the machine is in storage and the temperature may fall down to or below 32F (or 0° C) you should empty the water from the system:

- Pull out the hose of the tank (Fig.3.7) /The system is made of quick connect fittings and allows easy dismantling to release water./
- With compressed air blow out the water from the system in the two positions of the turn-cock.



Figure 3.7

4. OPERATION

PRELIMINARY CONTROLS

Inspect the working area as explained in the safety instructions. Fill in the water tank for wet use or connect the vacuum extractor and ensure that the vacuum hose is clear and it will follow the machine easily.

Make sure the bonnet air filter on top of the engine is clean. It should be cleaned hourly.

Check the engine oil level, screw the dipstick in to get reading. Make sure the tank is full (see also "Storage Propane tanks).

TANK and FUEL LINES - Check the tank and fuel lines for any sign of wear and tear, such as cracks or any corrosion. Screw the brass fuel line fitting onto the tank service-valve (hand tight only). This connection **MUST** be secure because the service valve has a safety valve inside it, which will only open if the brass fuel-line fitting is **COMPLETELY** seated into the service valve.

FUEL-MINDER USER MANUAL

The SM40 Fuel-Minder is a high-performance, digital fuel control system featuring closed loop feedback, fuel lock-off capability, emissions safety warnings with shutdown, and an LCD screen for user interface. The system is highly responsive to changes in engine load, providing optimum the air-to-fuel ratio regardless of operating conditions.

SYSTEM COMPONENTS

The following parts are included with the system

- Electronics Module
- Integrated Wire Harness
- Fuel Control Valve
- Fuel Control Housing
- O2 Sensor
- LPG Regulator with lock-off

Individual items are available as replacement parts if necessary

OVERVIEW OF FEATURES

Closed Loop Fuel Management System

The Fuel-Minder uses closed-loop feedback from the O2 sensor to control the amount of fuel introduced to the engine via the Fuel Control Valve. This technology continuously monitors engine emissions and is capable of making fuel corrections to compensate for varying engine loads and conditions.

FAULTY O2 SENSOR DETECTION

If a faulty O2 sensor is detected, the Fuel-Minder will alert the user within 3-5 minutes from a cold-start. A message will be displayed on the LCD screen to let the user know that the O2 sensor needs to be replaced.

BUILT-IN FUEL LOCKOFF CONTROLLER

The Fuel-Minder also controls the fuel lock off and only allows fuel to pass through if it detects the engine is cranking. Once the Fuel-Minder is powered off from the equipment key switch, the Fuel-Minder closes the fuel lock off and shuts the engine down immediately.

EMISSIONS WARNINGS AND SHUTDOWN

If the Fuel-Minder detects engine emissions that are too lean or rich for a period of 5 minutes, it will shut the engine down via the fuel lock off. The Red LED will blink and the LCD will display a message alerting the user of the issue and will prompt some common fix suggestions.

DUAL HOUR METERS

The Fuel-Minder has two hour meters, one for the engine and the other for equipment. The Engine Hours are resettable, which should only be done if the engine is replaced. The Equipment Hours (located in Options Menu) is non-resettable and shows the total hours on the equipment, similar to the odometer of a vehicle.

BATTERY VOLTMETER

This feature allows for real-time display of the battery's voltage, which also helps for troubleshooting any battery or charging system issues that may arise.

ENGINE TACHOMETER

Displays the current engine speed (in RPM). This should be used to assess proper idle, WOT and engine speed for the appropriate tooling.

JOB TIMER

The job timer feature works when it is activated and while the engine is running, and will not continue to run if the engine is stopped. The **job timer** allows for easy timing of jobs or work areas to help determine speed.

PASSWORD PROTECTION

Located in the options menu, the password feature allows a maintenance manager or owner to enable a password that prevents the user from resetting the Service Due alerts without the appropriate pin.

SERVICE ALERTS

The Fuel-Minder also provides equipment-specific service alerts for the following items:

- Air Filter
- Oil Change + Filter
- Spark Plugs
- Seal Replacements
- Chain Inspections
- Belt Inspections
- Tooling Inspections

Each item has individual alerts at different hour intervals, and the Fuel-Minder will start alerting the user of upcoming maintenance within 3 hours of when it is due. To reset a particular service alert, simply scroll to it, using the + or - buttons, then hold the reset button for 2 seconds. The meter will then prompt you to reset that interval.

SLEEP MODE

To conserve equipment battery life, the Fuel-Minder will enter sleep mode if there are no key inputs or engine activity. The backlight will dim after 30 seconds of inactivity, then turn off after 1 minute. The display will turn off after 2 minutes. To wake from sleep mode, simply press any key or start your engine.

MAIN MENU NAVIGATION AND USE

This section outlines how to navigate the menu and interact with certain features.

MAIN MENU

The Main Menu contains the following screens, which can be viewed by simply using the + and - buttons to scroll. Please note: Upon startup or waking from sleep mode, the first screen shown is always Engine Hours.

- Engine Hours (Default screen)
- Clean Filters
- Oil Change + Filter
- Spark Plugs
- Chain Inspections
- Seal Replacements
- Belt Inspections
- Tooling Inspections
- Battery Voltage
- Tachometer
- Options Menu

LED ALERTS & RESETTING SERVICE INTERVALS

The Fuel-Minder will alert you when service is due by blinking a red LED within 3 hours of the specified interval and displaying “Service Due” on the LCD screen. When you see this light, simply scroll through your menu to see which service item is due. To reset a specific interval, just scroll to that particular screen (for example, Oil Change), then hold the **SELECT** button for 2 seconds until you see the reset prompt, then press the **+** button to reset that interval.

OPTIONS MENU NAVIGATION AND USE

OPTIONS MENU

To enter the options menu, simply scroll until **Options Menu** is displayed on the screen, then press **SELECT**. The first option displayed by default is **Add Password**. Use the **+** or **-** buttons to scroll and view other options. To exit the options menu, scroll until you see **EXIT OPTIONS**, then press **SELECT**.

Add Password- This option allows you to add a password that prevents unauthorized users from resetting service intervals or performing a factory reset. This is a 4-digit pin that you set.

Change Password-Allows you to change your password, if one is saved. Note: This option is hidden unless a password has been created.

Remove Password-Used to disable the password feature, if a password is saved. Note: This option is hidden unless a password has been created.

Factory Reset-CAUTION, this option will erase all memory and restore your device to factory condition. This also allows for resetting the total engine hours. Password required if set.

Factory Unlock-This option is only used by Superabrasive and requires a factory assigned pin number to activate.

Tach Settings- This allows you to adjust the tachometer for a carbureted or fuel injected engine. It should come pre-set to the correct option and will not require changes.

Equipment Hours- This displays the total number of hours on your equipment and is non-resettable.

Date of Purchase-This can be used by the user or dealer to record the equipment purchase date. To enter the date, hold **SELECT** for 2 seconds; a cursor should appear under the MM. Use the **+** and **-** buttons to change the month field, then press **SELECT** to move to the Day field. Again, use the **+** and **-** buttons to select the desired day. Once you have the desired date, hold **SELECT** for 2 seconds and a prompt to save the information will appear.

Engine Info- To view the engine model/serial information, scroll to **Engine Info** in the Options Menu, and press **SELECT**. To edit this information, hold **SELECT** for 2 seconds. Then use the **+** and **-** buttons to select the appropriate letters and numbers. Press **SELECT** quickly to move the cursor, or hold **SELECT** for 7 seconds to save/exit.

Equipment Info- To view the equipment model/serial information, scroll to **Equipment Info** in the Options Menu, and press **SELECT**. To edit this information, hold **SELECT** for 2 seconds. Then use the **+** and **-** buttons to select the appropriate letters and numbers. Press **SELECT** quickly to move the cursor, or hold **SELECT** for 7 seconds to save/exit.

Job Timer- The job timer acts as a stopwatch, but only starts and stops when the engine is turned on/off. This allows you to accurately time how long your engine runs for a particular job.

Exit Options-Returns to the main menu, and default screen (Engine Hours).

SAFETY INFORMATION

Safety Information- Read all safety information before using this device to ensure safe and proper use.

Do not interact with the device while operating your equipment. Doing so may distract your attention and cause an accident, or may be illegal depending on your region.

Avoid any direct contact with pressure washers, water sprayers or cleaning chemicals of any kind.

Do not drop or cause an impact to the device.

Do not bend or twist the device and/or the wire harness excessively.

Do not disassemble, modify or repair your device. This product contains no user serviceable parts.

FCC Part 15.21

Any changes or modifications to this device that are not expressly approved by the manufacturer may void the user’s authority to operate the device.

WATER FLOW CONTROL SYSTEM

The operator can direct water to be sprayed in front of the machine (Fig.4.1) by positioning the lever in the horizontal position (Fig.4.2). Water will spray under the cover of the machine when the lever is in the vertical position (Fig.4.2). The pressure regulator is located above the lever (Fig.4.3) and controls the water pressure in the system. You can see the whole water flow control system - main and filtering parts in fig4.4. Fig. 4.5 and fig. 4.6 shows how to remove and clean the filter mesh. In the instances where more water is required to spray under the cover of the machine, the orifice plate (shown on pos.8 of table 7 in „spare parts“) can be removed.

ALWAYS USE CLEAN WATER TO PROTECT THE SYSTEM FROM DIRT.



Figure 4.1



Figure 4.2



Figure 4.3

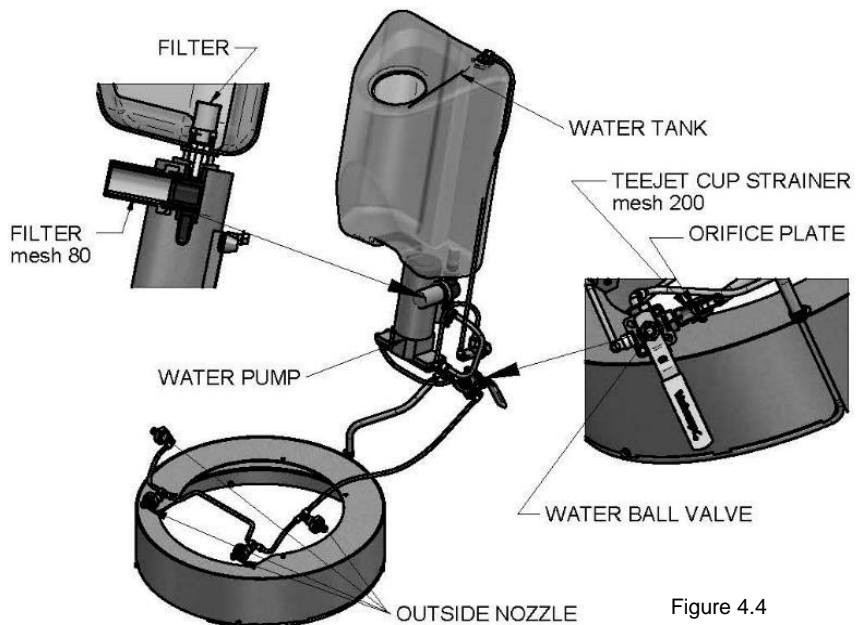

Figure 4.4



Figure 4.5



Figure 4.6

ADJUSTING AND MOUNTING TOOLS

The Holder A41 in LAVINA® E can work with either 3 or 6 buffers which will change its elasticity. You can make the change after dismantling the holder as per the instruction in TROUBLESHOOTING.

In Lavina 25GE the holder is initially mounted with 3 buffers.

Mount the tools only after ensuring that there is enough diamond bond material left. Be sure that the plates are always clean before mounting.

WARNING: Always Secure the Quick Change tools with the

security plate (Fig.4.7 in red), lock with the tool holder key (Fig.4.8) and make sure that the butterfly is securely locked at 90 degrees. Diamond tools with Velcro are attached on three foam plates (9 inch). The foam plates are mounted on the key lock (butterfly). Always use the tool holder key (Fig.5.1).



Figure 4.7



Figure 4.8

VACUUM CONNECTION

To connect a vacuum cleaner, the Lavina 25GE is supplied with vacuum hose Cam Lock inlet C250 / vacuum hose diam. 2,5 in (63mm) (Fig.4.9-2)

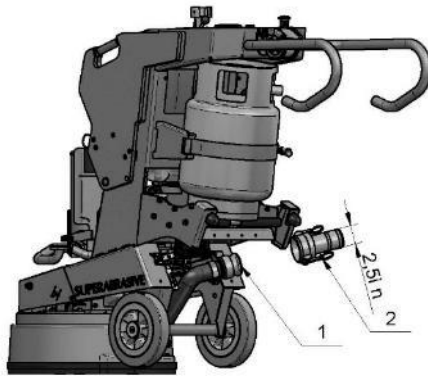
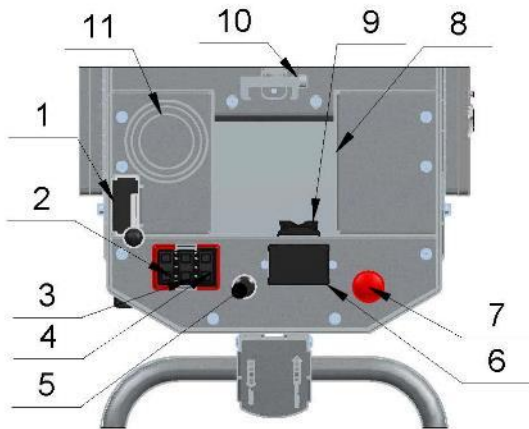

Figure 4.9

USE HORIZONTAL PROPANE TANK

The standard Lavina 25GE is equipped with vertical propane tank with vapor draw. If necessary the machine can work with horizontal tank but obligatory with vapor draw. Here is how to readjust the machine for horizontal propane tank:

- Dismount the support that carries the strap holding the tank. Dismount the strap from the support. Dismount the rear support of the tank. Remove half of the rubber insulator of the support. Place the strap in the middle of the tank support and place again the half of the rubber insulator. This support together with the strap should be mounted on the upper level.
- Dismount the front tank support and mount it on the upper level.
- Dismount the right support that has the tensioning key of the tank strap.
- Mount the key on the carriage using the plate underneath and the available screws and nuts. Adjust the locking depending on the diameter of the propane tank.
- While working do not forget that you should use properly fitted tank with vapor draw, to avoid freeze regulator problems.

CONTROL BOARD**THE CONTROL BOARD**

1 Throttle Push forward to accelerate.

2 Start/Stop clutch Start will electronically activate the grinding plates to spin; stop will disconnect engine from grinding heads

3 Water pump switch

4 Lights switch

5 Start/Stop Engine switch Turn key fully to the right (make contact) to ignite the engine. Fully to the left will arrest the engine.

6 Electronics Module of digital fuel control system When running, it indicates the revolutions per minute of the tool holders. When not running, it indicates the worked hours. The hour meter will blink between 48-52 hours as a reminder for oil change.

7 Emergency button used to stop the motor in case of emergency

8 Panel cover Under the cover is the 30 Amp fuse for the electrical system and the contacts separating the electrical system between carriage and the main head.

9 USB charger

10 Phone holder

11 Cover with cup holder

STARTING THE MACHINE

First, follow the directions in the chapter on Safety Devices and Safety Instructions. Check oil level. Open the service valve on the propane tank about one and a half (counterclockwise) turns. Next, make sure the Start/Stop Clutch rocker (2) is in stop position and check that the throttle (1) is in the IDLE position. This creates the necessary vacuum to open the lock-off valve inside the regulator. Actuation of the throttle lever will keep the lock-off valve from opening and the engine from getting fuel so the engine will not start. Proper maintenance will insure easy starting. Engage starter (5) for a **MAXIMUM** of 5 to 6 seconds or until the engine fires. Serious starter damage will result if this is exceeded and the warranty may not apply. Operate the engine at half throttle for approximately two minutes to properly warm engine. Then advance to full throttle for best results. If working wet, add water to the floor surface. If working dry, instead switch on the vacuum unit. Finally, hold the machine firmly and push the start of the Start/Stop clutch button (2).

OPERATING THE MACHINE

Guide the machine in straight lines across the floor, slightly overlapping the previously completed surface with each new line. Work at a constant speed, allowing the tools time to work at a speed appropriate for the tools' grit size. Avoid vibrations. Do not stop the machine while tools are still running as they will mark the surface of the floor. When working wet, select the destination of the water feed with the water tap (fig. 4.2-1) and periodically run the pump to release water onto the floor surface. Starting the pump is possible only if the machine motor is on. When working dry, check the floor surface periodically for dust accumulation. Check regularly to see if your vacuum works properly.

STOPPING THE MACHINE

Stopping of the machine must be done gradually.

To begin, disengage the clutch by pushing the Stop clutch rocker (2), and return the throttle (1) to the IDLE position. Wait 5-10 seconds. Turn the **Start/Stop Engine switch (5)** fully to the left in order to arrest the engine. Close (clockwise) the service valve on the propane tank.

- In case of an emergency **ONLY** press the "**Emergency Stop Button**" (7).

When you are finished with the machine, store the propane tank outside the building, in a **SECURE** place away from heat or direct sunlight.

5. TOOLS AND ACCESSORIES

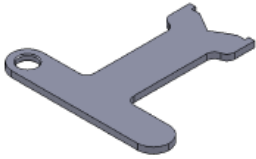

TOOL HOLDER KEY

The tool holder key (Fig. 5.1) is used for adjusting, mounting and dismounting of the foam plates. Always use the key for mounting.

Item number is A03.00.00.00

Figure 5.1



SECURITY PLATE FOR QUICKCHANGE PADS

Plate (Fig.5.2) used to ensure the "Quickchange" tools.

Item number is A63.00.01

Figure 5.2

6. POPULAR TOOLS

The heads have counter-clockwise / left rotation. Use the blue PCDs and Carbide Scrapers

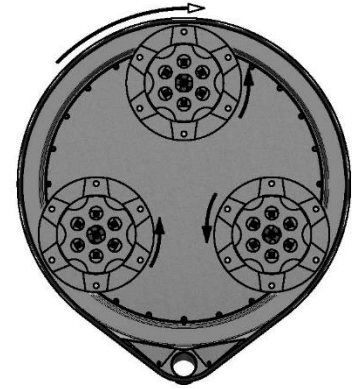

RECOMMENDED TOOLS



QuickChange System and Tooling feature extremely fast and convenient tool changes, and a long tool life, providing for great long-term cost savings. The QuickChange pads are produced in four different bonds for super hard, hard, medium and soft concrete, in a variety of grit sizes. They are offered with 1 or 2 buttons or rectangular segments, which allows you to customize the aggressiveness of the cut.



CORSA HYBRID DISCS WITH QUICK CHANGE ATTACHMENT (WET OR DRY) : The new Corsa hybrid discs are designed for scratch removal and transitioning from metal to resin tools, and are similar to Calibra but the ceramic bond has been modified for more efficient use on soft and medium concrete.



NATO® WITH QUICK CHANGE ATTACHMENT

Superabrasive's Nato resin pucks are a great tool choice for soft and hard concrete polishing applications. Among the thickest diamond pads on the market - featuring a thick 12mm layer of resin and diamonds for extra long life. Wide channels and a unique patented design allow for work on a cleaner surface, ensuring a quality polish. Offered in wet and dry bond.



V-HARR® Premium Polishing Pads for 9-inch TOOL HOLDERS NOW AVAILABLE IN A QUICK CHANGE STYLE - NO FOAM PLATES NEEDED

V-Harr felt diamond pads are one of Superabrasive's most versatile and successful diamond tools for concrete polishing. V-Harr pads are also ideal for polishing terrazzo and hard stone floors. V-Harr polishing pads should be used DRY on concrete! However, they will produce remarkable gloss results on black granite when used wet.

Use Only Superabrasive's Recommended Tools. For More Tooling Options, Visit www.superabrasive.com

7.MAINTENANCE AND INSPECTION

REMARK

Tampering w/Emission Control System Prohibited

Federal law and California State law prohibits the following acts or the causing thereof: (1) the removal or rendering inoperative by any person other than for purposes of maintenance, repair, or replacement, of any device or element at design incorporated into any new engine for the purpose of emission control prior to its sale or delivery to the ultimate purchaser or while it is in use, or (2) the use of the engine after such device or element of design has been removed or rendered inoperative by any person. Among those acts presumed to constitute tampering, involve the parts/systems listed below:

- Carburetor and internal parts
- Spark plugs
- Magneto or electronic ignition system
- Fuel filter element
- Air cleaner elements
- Crankcase
- Cylinder heads
- Breather chamber and internal parts
- Intake pipe and tube

MECHANICAL PARTS

Parts such as the belt, seal rings, cap rings, spiders, buffers, guard assembly, tires are subject to wear and should be replaced as needed.

CLEANING

Keep your machine clean. Cleaning the machine on a regular basis will help detect and solve potential problems before they cause damage to the machine. Most importantly, check and clean the tool plate connections, vacuum hoses, water tank and the Propane installation.

CHECK HOURLY

BONNET FILTER - Make sure the bonnet air filter at the top of the engine is clean. It should be changed hourly and thoroughly cleaned before reuse. The same for the recoil dust filter. If neglected the engine will overheat and carbon monoxide emissions will elevate.

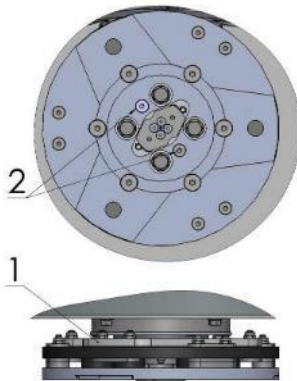

Figure 7.1

CHECK DAILY

After operating the Lavina® E machine, the operator should conduct a visual inspection of the machine. Any defect should be solved immediately. Pay attention to power cords, plugs and vacuum hoses, loose bolt or screws.

Tool holders: Buffers and elastic element are consumables and must be visually checked daily and replaced if needed. See that flanges or discs are mounted and locked well in place. The key lock holders (butterflies) should be also checked.

Check the rubber buffers and fixing of the holders. The flange holding the buffers (Fig.7.1_1) has to be firmly fixed to the unit. A gap seen there means that there are loose screws fixing the holder. The screws have to be tightened immediately for safe operation. Working with loose screws on the holder could also cause bad damages on the machine. Tightening force of the screws has to be 22...25N.m(16...18 ft/lbs).

It is very important to regularly check the screws (Fig.7.1_2) that fix the "Quickchange" holder to the safety part, so that the holder will not fly away if the buffers get damaged. "Quickchange" should be clean.

CHECK AND REPLACE AFTER THE FIRST 8 WORKING HOURS

Replace the oil in the engine after the first 8 hours work, according to the instructions of the engine manufacturer.

Always use 30HD or 10W30 engine oil with all of the following ratings: SF, SG, and CC

CHECK AND REPLACE EVERY 50 WORKING HOURS

Change engine oil, while changing check for leakage of engine oil at the various seals. The hour meter will blink between 48-52 hours as a reminder. /"Engine Oil Capacity" is 1.5L(1.6US.qt) when oil filter is not removed 1.7L(1.8US.qt) when oil filter is removed/.

Recommended Oil Change Intervals

Do not exceed the 50-hour oil change interval. Oil changes more frequent than 25 hours will give even longer engine life. In any case, always use 30HD or 10W30 engine oil with all of the following ratings: SF, SG, and CC. make sure the oil level is maintained at the "FULL" level.

CHECK AND REPLACE EVERY 200 WORKING HOURS

Every 200 working hours the operator should inspect all parts of the machine carefully. Most importantly, inspect and clean the tool plate connections, vacuum hoses and water tank. Also, check the water flow. Check the guard assembly. Make

certain the wheels are clean and rotate properly. Inspect the control buttons. If there are defective control parts, they should be replaced immediately. Replace worn vacuum- and water hoses.

Carefully inspect the seal rings and bearings of the grinding units, and replace any showing signs of excessive wear. For more information, refer to chapter troubleshooting below.

Open the service cover on the motor base (Fig 7.2) (Fig 7.3) to check of the planetary chain. Lubricate the chain with special lubricant for chains and correct the sag if needed. For sagging correction (See TROUBLESHOOTING).

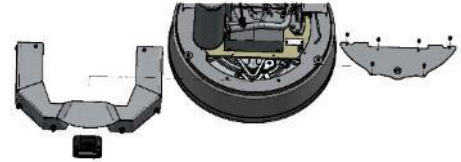

Figure 7.2

Dismount the tool holders (See Troubleshooting) replace all parts (elastic element, buffers, sealers) with the slightest damage or consume. **Return** machine to **authorized service center** for overall checkup of the Engine. For Propane safety, have the machine serviced by a **Certified Technician**, including emission check.

CHECK AND REPLACE EVERY 400 WORKING HOURS

Besides the checks of 200 working hours, replace sealer and V-rings like described in chapter "TROUBLESHOOTING REPLACING BELT AND PULLEY UNITS. Check if belts and bearings are in good condition, change if needed. Return machine to authorized service center for overall checkup of the Engine. For Propane safety, have the machine serviced by a Certified Technician, including emission check.



Figure 7.3

VACUUM

As stated previously, frequently check hoses and other parts for clogging.

WATER LEAKS

Replace any leaking parts immediately as the water could damage your machine

MECHANICAL PARTS

Parts such as the belts, seal rings, cap rings, spiders and buffers and guard assembly are subject to wear and should be replaced as needed.

OPERATION	INTERVAL							
	Daily	First 8 Hrs.	Every 50 Hrs.	Every 100 Hrs.	Every 200 Hrs.	Every 300 Hrs.	Every 400 Hrs.	Every 500 Hrs.
Check & add engine oil	X							
Check for loose or lost fasteners	X							
Check for oil leakage	X							
Inspect fuel hose and connections	X							
Clean engine dust filter	X							
Inspect throttle & wire	X							
Change engine oil		X	X					
Change engine oil filter		X		X				
Replace engine primary air filter						X		
Replace engine pre filter								X
Inspect battery and battery connections				X				
Inspect, clean & re-gap spark plugs, Replace if necessary								
Check & adjust valve clearance * Re-torque heads *						X		
Clean & lap valve seating surface *						X		
Check engine emissions								X
Inspect power cords, plugs and vacuum hoses, loose bolt or screws.	X							
Check the rubber buffers, elastic element and fixing of the holders	X							
Inspect and clean the tool plate connections					X		X	
Inspect and clean water tank, filters mesh and misting nozzle					X		X	
Inspect the seal rings and bearings of the grinding units					X			
Check the planetary chain and lubricate					X		X	
Replace Felt-Ring and V-rings							X	
Check belts and bearings							X	

* Return machine to authorized service center for overall checkup of the Engine. For Propane safety, have the machine serviced by a Certified Technician, including emission check.

8. TROUBLESHOOTING

8.1 ENGINE

When troubles occur, be sure to check the simple causes which at first, may seem too obvious to be considered. For example, a starting problem could be caused by fuel starvation due to an empty propane cylinder or an unopened service valve. If you do not check for this, starter burnout could result.

Some Troubles and solutions:

Surging idle

To smooth out the engines' idle characteristics, adjustment is provided by an idle screw on the lower left side of the carburetor as viewed from the operator's position. The screw is bright steel and 1/4" in diameter with a Phillips head on it. Rotating the screw clockwise will increase the idle speed and this should cure the "surging idle". If it does not, call our customer service.

Engine starts and idles, but will quit as the throttle is advanced

It is possible that the propane tank's service valve is faulty. To check for this, close the valve completely and then reopen very slowly while you listen for a "click" when the gas begins to travel through the valve. If you hear this very slight noise, the valve is only partially opening. This allows enough gas through to start and idle the engine, but not enough for full throttle operation. As the throttle is increased, allowing more air to enter the intake, the engine will quit from fuel starvation. Call your dealer or the factory for instructions on where to have the service valve replaced. Meanwhile, to get by, you can continue to open the service valve until you do not hear a "click" and then the engine will run normally. If it does not, call your customer service.

Starter barely turns the engine over or the solenoid just clicks

The battery is likely low in charge. This can be remedied by recharging the battery using a 12 Volt battery charger at 4.12 amperes. The battery is located on the left side of the propane tank holder under the battery cover. The positive post is the one with the RED cable attached to it. Follow the instructions that came with the battery charger. REMINDER: this will continue to happen unless your engine is run for sufficient time between starts to recharge the battery.

Electrical schemes with Kawasaki Engine

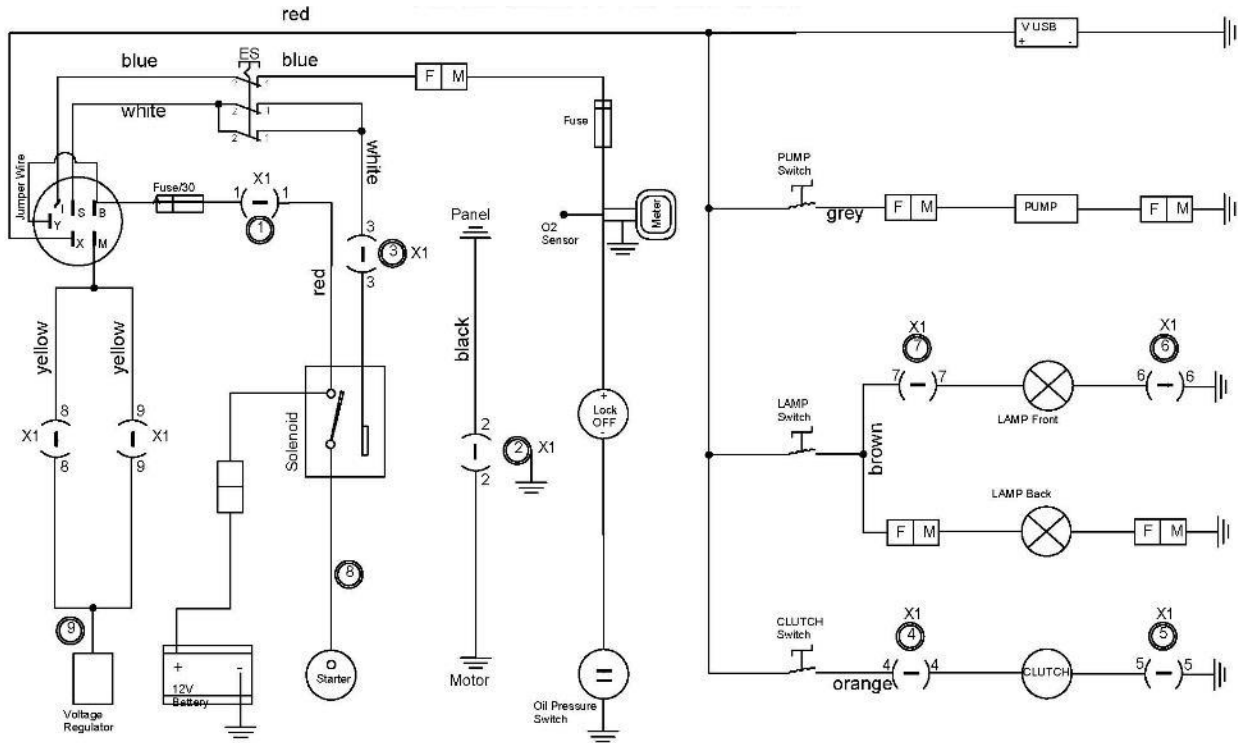

8.2 CHECKING AND CHANGING OIL

Check the engine oil level, screw the dipstick in to get reading. While changing engine oil, check for leakage of engine oil at the various seals.

Do not exceed the 50-hour oil change interval. Oil changes more frequent than 25 hours will give even longer engine In any case, always use 30HD or 10W30 engine oil with all of the following ratings: SF, SG, and CC. make sure the oil level is maintained at the "FULL" level.

8.2 CHECKING AND CHANGING OIL

Check the engine oil level, screw the dipstick in to get reading. While changing engine oil, check for leakage of engine oil at the various seals.



Figure 8.2.1



Figure 8.2.2

Do not exceed the 50-hour oil change interval. Oil changes more frequent than 25 hours will give even longer engine In any case, always use 30HD or 10W30 engine oil with all of the following ratings: SF, SG, and CC. make sure the oil level is maintained at the "FULL" level.

8.3 DISMOUNTING/MOUNTING THE GUARD

You can dismount and mount the safe guard without separating the carriage from the main head. Put the machine in position to change the tools.

Unscrew the four bolts M5 from the metal cover preventing the safe guard to fall. Dismount one of the three holders. Dismount the safe guard.

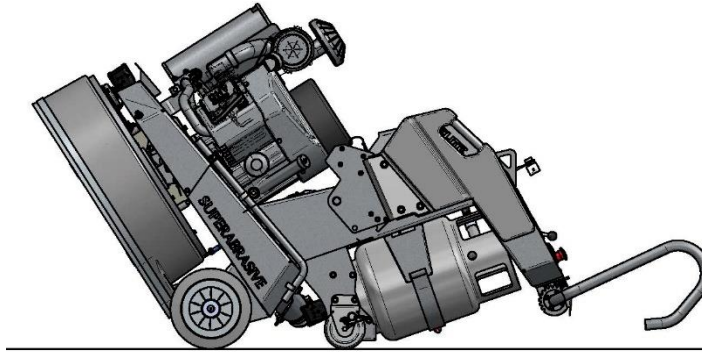

Figure 8.3



Figure 8.4

8.4 SEPARATING THE HEAD FROM THE CARRIAGE

Please note that the propane cylinder has to be removed and stored outside before any maintenance or reparation is done.

1. Disconnect the flexible hose supplying water under the cover of the machine/ Fig. 8.4.1/. All water connections in the machines are with fittings types „Push-In “ and „Release button“.

2. Unscrew the two bolts and nuts to disconnect the vacuum connector from the carriage. /Fig. 8.4.2/.

3. Disconnect the cable of the battery/ Fig. 8.4.3/.

4. Remove the lamp /on magnetic attachment/ and disconnect the cable /Fig. 8.4.4/.

5. Unscrew the four bolts to remove the panel /Fig.8.4.5;Fig.8.4.6;Fig.8.4.7/.

6. Dismount the panel holding the tank /Fig.8.4.8/.

7. Disconnect the control panel carrying the throttle lever and move it to the main head / Fig.8.4.9; Fig.8.4.10;Fig.8.4.11;Fig.8.4.12/



Figure 8.4.1

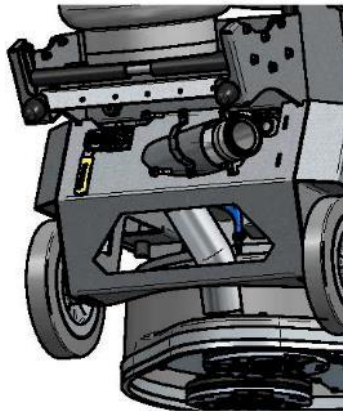

Figure 8.4.2



Figure 8.4.3



Figure 8.4.4



Figure 8.4.5



Figure 8.4.6



Figure 8.4.7

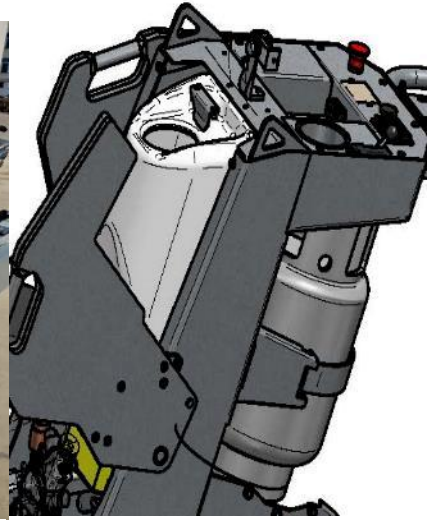

Figure 8.4.8



Figure 8.4.9



Figure 8.4.10



Figure 8.4.11



Figure 8.4.12

8. Dismount the right cover on the control panel. Underneath is the coupling to disconnect the control module from the motor. Disconnect the coupling, disconnect the cable and move it to the main head /Fig.8.4.13;Fig.8.4.14;Fig.8.4.15;Fig.8.4.16;Fig.8.4.17;Fig.8.4.18;Fig.8.4.19/.



Figure 8.4.13



Figure 8.4.14



Figure 8.4.15

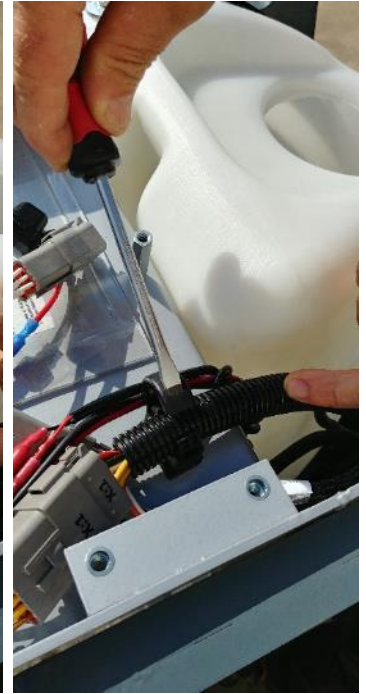

Figure 8.4.16



Figure 8.4.17



Figure 8.4.18



Figure 8.4.19

9. Remove the mist nozzles system and carefully stop the connection to the water system.



Figure 8.4.20



Figure 8.4.21



Figure 8.4.22



Figure 8.4.23

10. Now it is possible to separate the head by removing the pins. This will require two people: one person holds the carriage while the other pulls the pins (Fig. 8.4.24; Fig. 8.4.25). After removing the pins, carefully pull the carriage backwards to ensure that there is no collision with the engine oil drain plug or other part of the main head.

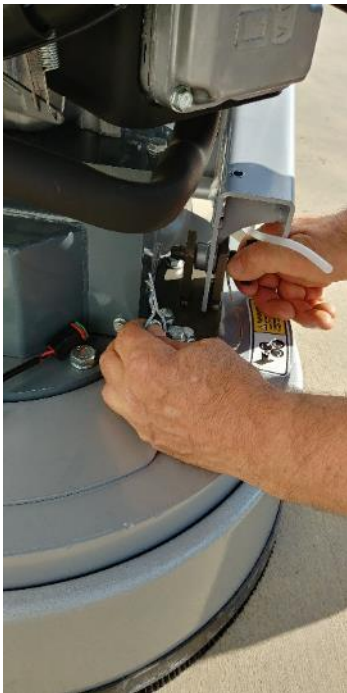

Figure 8.4.24



Figure 8.4.25



Figure 8.4.26



Figure 8.4.27

8.4 DISMOUNTING/MOUNTING THE ENGINE



Figure 8.4.1



Figure 8.4.2



Separate head from carriage (see previous chapter). Remove front (Fig. 8.4.1) and back belt protection (Fig. 8.4.2). Loosen the motor base plate (Fig. 8.4.3), release the tension device (Fig. 8.4.4), and take out the belt (Fig. 8.4.5). Take off the engine (Fig. 8.4.6).



Figure 8.4.4



Figure 8.4.5



Figure 8.4.6

Reassemble in the same manner. (Fig. 8.4.7), Tension the belt with bolt (4) on (fig. 8.4.7) or (fig. 8.4.4) The belt tension can be tested with a Frequency tension Tester Optibelt 3 TT- (190-200Hz) or manual by pushing with a force of 6 kg or 13 lbs in point A, the deflection of the belt must be 3,1 mm or $\pm 1/8$ Inch

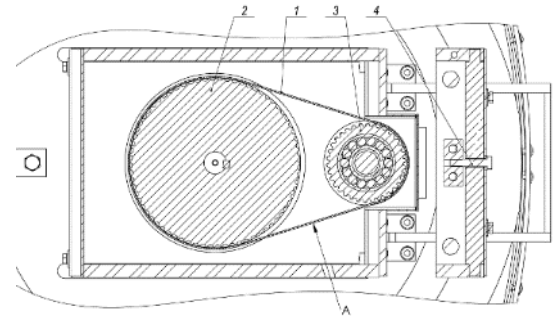

Figure 8.4.7

ATTENTION:
NEVER "OVER" TENSION THE BELT, THE BELT WILL BE DESTROYED AND IT WILL NEVER RECOVER ITS ORIGINAL TENSION

8.6 REPLACING THE CLUTCH



Figure 8.6.1



Figure 8.6.2



Figure 8.6.3



Figure 8.6.4

In case the electric clutch has to be replaced, remove the engine (see previous chapter) and lay it on its side with the oil drainage up (Fig. 8.6.1) and loose the front nut to dismount the clutch (Fig. 8.6.2 and Fig. 8.6.3). Reassemble in the same manner. Do not forget to mount back the washer on the shaft (Fig. 8.6.4). The torque on the front nut (Fig. 8.6.3) to mount the pulley and clutch should be 70 Nm or 52 ft lbs (Fig. 8.6.2 and Fig. 8.6.3).

8.7 DISMOUNTING TOOL HOLDER TO CHANGING V-RINGS AND FELT-RINGS



Figure 8.7.1



Figure 8.7.2

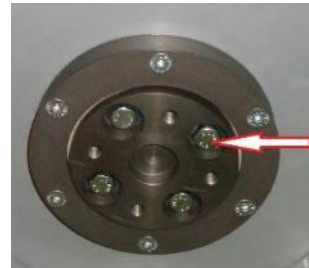

Figure 8.7.3



Figure 8.7.4



Figure 8.7.5



Figure 8.7.6

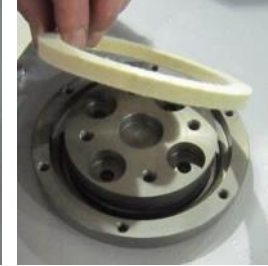

Figure 8.7.7



Figure 8.7.8

To check or replace the buffers and the elastic elements , the tool holders have to be dismantled.

You will need deep metric socket 13mm with outside diameter not more than 3/4in to unscrew the four bolts (Fig.8.7.1) and remove the holder (Fig.8.7.2)

When the tool holder is dismantled, you can change the sealers (V-Ring and Felt-Ring).

By loosening four Hex cap flange bolts (Fig.8.7.3) the adaptor comes loose- Unscrew the six screws of the cap (Fig.8.7.4) holding the felt-ring. Take out the Felt-Ring, adaptor and V-Ring.

Mount the V-Ring with the smallest lip of the V to inside (Fig.8.7.5) just push the V-Ring so the top is on the same level as the pulley top (Fig.8.7.6). Then take the adaptor and push the V-Ring down with the adaptor (Fig.8.7.7).

The lowest lip of the V-Ring should only barely touch its gliding surface; also never push the V-Ring down with fingers. Mount the adaptor and the Felt-Ring on top (Fig.8.7.7). Close the sealers with the cap (Fig.8.7.8) and screw the bolts. Always use the original bolts. Do not push the V-ring down with fingers.

8.8 DISASSEMBLING AND MOUNTING TOOL HOLDER TO CHANGE BUFFERS AND ELASTIC ELEMENT

When the TOOL HOLDER is disassembled you can change defective parts – elastic element, buffers, etc.

Lift the locking pin (Fig.8.8.1) to dismount the retaining washer (Fig.8.8.2). Take out the screws on the buffers and the nuts of the elastic element (Fig.8.8.3;Fig.8.8.4).

Remove the elastic element from the QC plate (Fig.8.8.5). While the holder is dismantled (Fig.8.7.6;Fig.8.8.7)

clean the parts and replace the defective with new ones. Assemble the holder with new buffers with new screws and new elastic element. Put the retaining washer (Fig.8.8.8) and push the locking pin (Fig.8.8.9).

This will prevent the fall of the washer when mounting the holder on the machine.



Figure 8.8.1



Figure 8.8.2

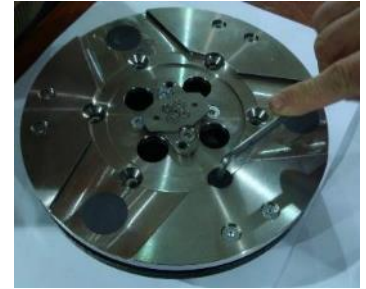

Figure 8.8.3



Figure 8.8.4



Figure 8.8.5



Figure 8.8.6



Figure 8.8.7

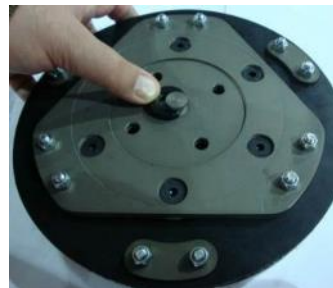

Figure 8.8.8

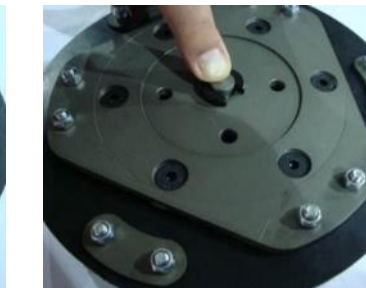

Figure 8.8.9

Make sure the four bolts holding the adaptor (Fig.8.8.12) are reliably tighten.

Mount the holder on the machine using the same socket as mentioned in 8.6 (Fig.8.8.10;Fig.8.8.11).

The retaining washer fits into the central hole C of adaptor and the four bolts into the thread holes T (Fig.8.8.12). The holder is centered on the outside diameter of the adaptor. Ensure the connection of the holder on the forehead of the adaptor and then tight evenly the four bolts. Tightening force of the bolts has to be 22...25N.m(16...18 ft/lbs). Mounting the holder without retaining washer (Fig.8.8.2) is

INADMISSIBLE because the security system preventing the separation of part of the holder in case of broken buffers and elastic element will not function! You can change the butterfly of the holder without dismantling the holder of the machine. Fig.8.8.13 is 3-d section view of the holder, showing its parts. The numbering is the same as in Spare parts.



Figure 8.8.10



Figure 8.8.11

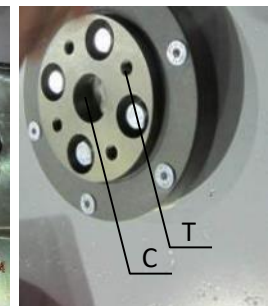

Figure 8.8.12

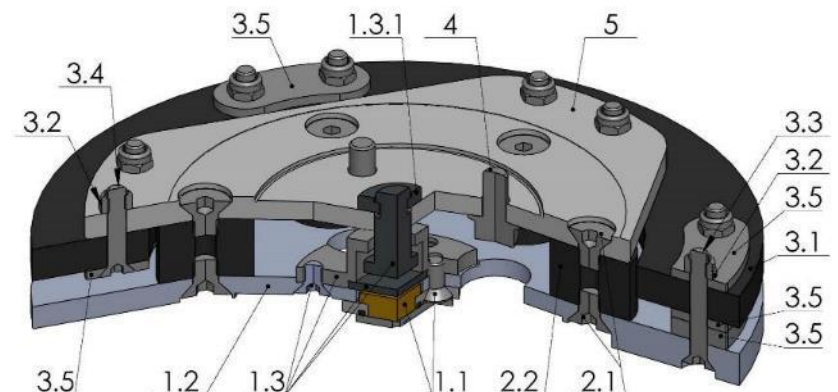

Figure 8.7.13

8.8 CORRECTING DEFLECTION OF THE USED PLANETARY CHAIN

Unscrew the bolts and take out the cover (Fig.8.8.1). Lift the machine in position to change the tools. Turn manually the holders in order to turn the main head, stop when you see through the window the chain tensioner (Fig.8.8.2).

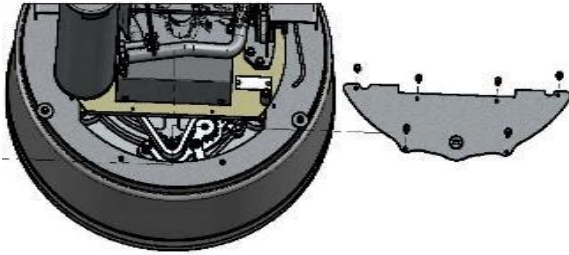

Figure 8.8.1



Figure 8.8.2

Loosen a quarter to 1/2 rev the two bolts of the chain tensioner (Fig.8.8.3) the tensioner should turn with minimum clearance, without inclination, then unscrew the inner nut. To

tension the chain screw the outer nut (Fig.8.8.4). The tensioner of the planetary chain should allow chain sagging 3...5mm/1/8...3/16 in/ controlled in span X (Fig.8.8.5). When ready screw the two nuts (Fig.8.8.4) and the screw(Fig.8.8.3).



Figure 8.8.3



Figure 8.8.4



Figure 8.8.5

ATTENTION: NEVER “OVER” TENSION THE CHAIN, THE CHAIN WILL BE DAMAGED

8.9 MOUNTING NEW PLANETARY CHAIN

The planetary chain is replaced with new one when the step/drive of the chain tensioner is finished or there is a break in the integrity of the chain. Unscrew the bolts (Fig.8.9.1) and take out the cover. Lift the machine in position to change the tools. Turn manually the holders in order to turn the main head, stop when you see through the window the chain tensioner (Fig.8.8.2). Separate the carriage from main head, point 8.4 , pull out motor plug, water tubes and vacuum tubes. Take off handle (without water tubes). Release the pin sets which attach the head to the carriage. Take off the service

window (Fig. 8.9.1) so you can dismount the top cover(Fig. 8.9.2)

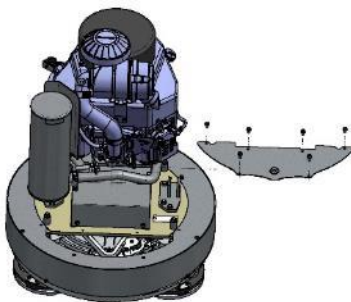

Figure 8.9.1

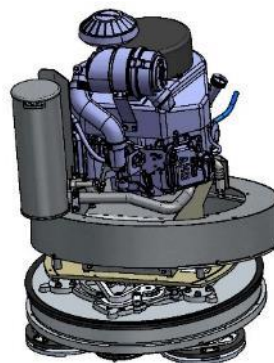

Figure 8.9.2

Loosen the two nuts(Fig.8.8.6) and uscrew the two screws of the tensioner (Fig.8.8.5)(Fig.8.9.4)(Fig.8.9.5). Take the chain tensioner(Fig.8.9.6). Pull out the split pin (Fig.8.9.7) and the chain link pin (Fig.8.9.8) (Fig.8.9.9). Take the chain, and put on the same way the new chain, get in the chain link pin and the split pin (Fig.8.9.9) (Fig.8.9.8)

(Fig.8.9.7).



Figure 8.9.4



Figure 8.9.5



Figure 8.9.6



Figure 8.9.7



Figure 8.9.8



Figure 8.9.9

Mount the chain tensioner (Fig.8.8.6). Screw the two screws (Fig.8.9.4)(Fig.8.8.5). Loosen a quarter to 1/2 rev the bolt of the chain tensioner (Fig.8.8.5) the tensioner should turn with minimum clearance, without inclination, then unscrew the inner nut. To tension the chain screw the outer nut (Fig.8.8.6) . The tensioner of the planetary chain should allow chain sagging 3...5mm/1/8...3/16 in/ controlled in span X (Fig.8.8.7).

When ready screw the two nuts (Fig.8.8.6) and the screw(Fig.8.8.5).

ATTENTION: NEVER “OVER” TENSION THE CHAIN, THE CHAIN WILL BE DAMAGED

8.10 REPLACING THE PLANETARY DRIVING CHAIN WHEEL AND PLANETARY TENSIONER

Check and repeat the instruction in 8.9 MONTING NEW PLANETARY CHAIN.

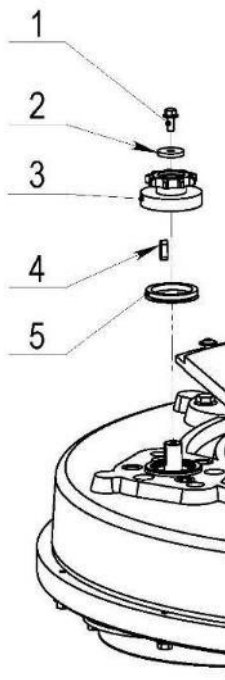

Figure 8.10.1

Unscrew bolt pos.1 take the chain pulley pos.3 together with the sealer pos.5. Change the sealer and mount it to the chain pulley pos.3. Apply lithium grease on the shaft and mount back the wheel and the front washer pos.2 as shown on (Fig.8.10.1). Screw the bolt by using always the “blue” thread locking adhesive. Tightening force of the bolts has to be 22...25N.m(16...18 ft/lbs).

8.11 TENSIONING AND REPLACING THE BELTS



Figure 8.11.1

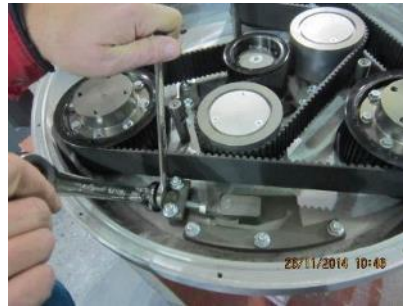

Figure 8.11.2

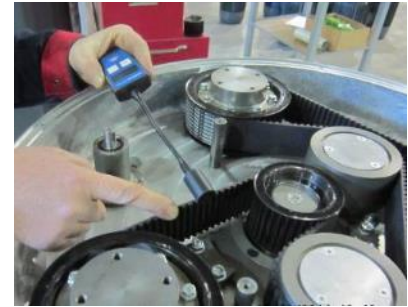

Figure 8.11.3

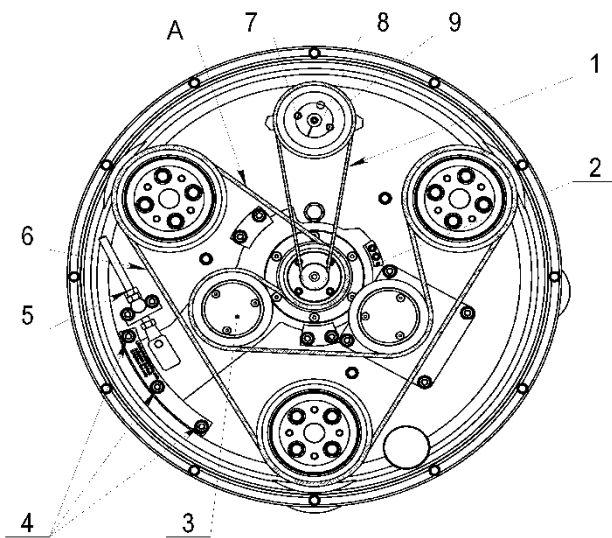

Figure 8.11.5

The transmission of the machine runs two timing belts (a main belt that rotates the plates (and tools) and an auxiliary planetary belt which propels the rotation of the head as a whole). To change the main belt, remove all plate mounts (...Holders) and adapters. There will be a seal to remove as well. Check any friction surfaces for wear, and replace if necessary. To remove the bottom cover, unscrew the bolts at the circumference of the cover, as well as those in the spacers. We recommend that all seals (O-Rings in the pacers and seal around the cover) be replaced when changing belts.

Figure 8.11.5 shows the scheme of the belts. To remove the old belts first remove the planetary belt (1) and then the main belt (6).

To remove the main belt (6), loosen nuts (4) and (5) enough to be able to turn the tensioners (3) around the central axle. Clean the washers and surrounding area, and check all bearings of pulley units/tensioners for too much clearance or rolling noise. Rotating the tensioner will allow the centre distance to be reduced in such that the timing belt may be fitted without force. Installation with the use of force is NOT permissible at any time as this can damage

the high quality, low stretch tension cord and other components. This damage is often not visible. Arrange the belts in pos.6 as per the scheme, paying attention to their orientation at every pulley. Loosen the nuts (5) to the end of the bolt, and fully loosen the nuts on the half moon (4), allowing the rotation of the tensioners with minimal force.

Using nuts (5), tighten the belt, double checking the position/orientation of the belt and the gearing in each pulley.

Rotate the gear while tensioning to allow regular distribution of tension along the belt.

Measure the tension using a Frequency Tension Tester (Optibelt 3 TT) (Fig. 8.11.3). Tension in span "A" of the belt should be 120-130Hz. It is possible to use the pre-installed support (Fig. 8.11.5-2)(Fig. 8.11.6) as a reference to stop the tensioner at the desired belt tension, provided that the supports have not been moved from their factory position.

ATTENTION: NEVER "OVER" TENSION THE BELT, THE BELT WILL BE DESTROYED AND IT WILL NEVER RECOVER ITS ORIGINAL TENSION



Figure 8.11.6

To dismantle the planetary belt (Fig.8.11.5-1) unscrew the screw of the front washer (Fig.8.11.7) and the two screws of the conical sleeve (Fig.8.11.8). Screw one screw in the free thread(Fig.8.11.9), to push the washer down (Fig.8.11.10); take the conical sleeve and the belt (Fig.8.11.11).



Figure 8.11.7



Figure 8.11.8



Figure 8.11.9



Figure 8.11.10



Figure 8.11.11

The Ressembly is on reverse order, and is important to match the threads of the conical sleeve and the belt washer(Fig.8.11.13). Put the front washer (Fig.8.11.14), on the screw use always the "blue" thread locking adhesive.

Tightening force of the bolts has to be 4,5...6N.m(3,3...4,4 ft/lbs). Put carefully the two binder screws by leaving the central thread free.(Fig.8.11.14)(Fig.8.11.15). Insert the screws up to revolution and ½ by alternating until the conical sleeve pull up the belt pulley. The conical sleeve must be aligned in height with the belt washer(Fig.8.11.16).



Figure 8.11.13



Figure 8.11.14

Dismounting the planetary belt is possible without removing of the Bottom cover assembly. Unscrew the eight bolts, take the service window cover and the sealing(Fig.8.11.17)(Fig.8.11.18). Dismount the planetary belt (see 8.11.)



Figure 8.11.15



Figure 8.11.16



Figure 8.11.17



Figure 8.11.18



Figure 8.11.19

8.12 REPLACING THE PLANETARY DRIVEN CHAIN WHEEL

Dismount the planetary chain and the tensioner and see Fig.8.9(MONTING NEW PLANETARY CHAIN).

Dismount the tool holders, sealers and bottom cover see Fig.8.11(TENSIONING AND REPLACING THE BELTS).

Unscrew the cap that gives access to the fastening bolts of the driven chain wheel (Fig.8.12.1)(Fig.8.12.2). Roll the main head to the position when from the hole of the cap you see a fastening bolt of the driven chain wheel (Fig.8.12.3).

You will need magnetic deep metric socket 10mm with outside diameter not more than 11/16 in to unscrew the six bolts (Fig.8.12.3)(Fig.8.12.4) (Fig.8.12.5).

Driven Chain Wheel is composed by two symmetrical halves(Fig.8.12.6). Mount on the reverse order.

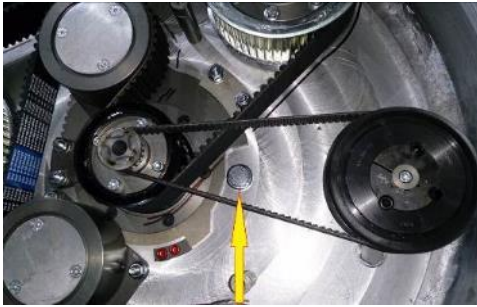

Figure 8.12.1



Figure 8.12.2

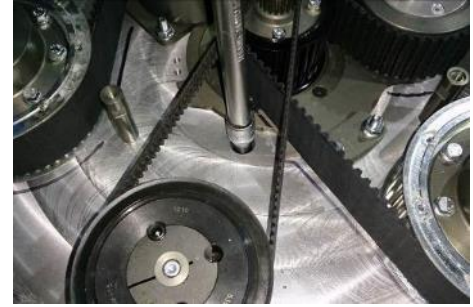

Figure 8.12.3



Figure 8.12.4



Figure 8.12.5



Figure 8.12.6

8.13 REPLACING THE PULLEY UNITS

Dismount guard, top cover, maintenance window chain tensioner, driven chain wheel, bottom cover and belts as previous described.



Figure 8.13.1



Figure 8.13.2



Figure 8.13.3

Unscrew the four bolts of each pulley between the base plate and the motor base disc (Fig.8.13.1)(Fig.8.13.2) and dismount the pulley (Fig.8.13.3).

A seal (Fig.8.13.4) should be placed on top of the pulley before mounting.



Figure 8.13.4

8.14 REPLACING THE PLANETARY UNIT



Figure 8.14.1



Figure 8.14.2



Figure 8.14.3

Unscrew the six bolts (Fig.8.14.1)(Fig.8.14.2) and press down the planetary unit. When mounting back secure with sealant (Fig.8.14.3).

9. DISPOSAL

If your machine after time is not usable or needs to be replaced, send the machine back to Superabrasive or a local distributor, where a professional disposal complying with the environment laws and directives is guaranteed.

10. MANUFACTURER'S CONTACTS

If you need to contact Superabrasive Inc. with technical support questions, below is the contact information.

Address: 9411 Jackson Trail Road, Hoshton GA 30548, USA
Email: info@superabrasive.us
Tel.: 706 658 1122
Fax: 706 658 0357

11. Emission Control Warranty Statement

CALIFORNIA EMISSION CONTROL WARRANTY STATEMENT YOUR WARRANTY RIGHTS AND OBLIGATIONS

The California Air Resources Board and Superabrasive Inc. are pleased to explain the emissions control system warranty on your 2016 small off-road engine (SORE). In California, new SORE must be designed, built and equipped to meet the State's stringent anti-smog standards. Superabrasive Inc. must warrant the emission control system on your SORE for the period of time listed below provided there has been no abuse, neglect or improper maintenance of your SORE.

Your emission control system may include parts such as the carburetor, fuel-injection system, the ignition system, catalytic converter, fuel tanks, fuel lines, fuel caps, valves, canisters, filters, vapor hoses, clamps, connectors, and other associated emission-related components.

Where a warrantable condition exists, Superabrasive Inc. will repair your SORE at no cost to you including diagnosis, parts and labor.

MANUFACTURER'S WARRANTY COVERAGE

The emission control system is warranted for 2 years. If any emission-related part on your equipment is defective, the part will be repaired or replaced by Superabrasive Inc.

OWNER'S WARRANTY RESPONSIBILITIES

As the small off-road engine (SORE) owner, you are responsible for the performance of the required maintenance listed in your owner's manual. Superabrasive Inc. recommends that you retain all receipts covering maintenance of your SORE engine, but Superabrasive Inc. cannot deny warranty solely for the lack of receipts or for your failure to ensure the performance of all scheduled maintenance.

As the SORE owner you should however be aware that Superabrasive Inc. may deny your warranty if your SORE or its part has failed due to abuse, neglect, improper maintenance or unapproved modification.

You are responsible for presenting your utility equipment engine to a Superabrasive Inc. distribution center as soon as the problem exists. The warranty repairs should be completed within a reasonable amount of time, not to exceed 30 days. If you have any questions regarding your warranty rights and responsibilities, you should contact Superabrasive Inc. at 1-(800)-987-8403 or by e-mail at info@superabrasive.us

Superabrasive Inc
9411 Jackson trail Rd
Hoschton, GA
USA, 30548

GENERAL EMISSIONS WARRANTY COVERAGE

Superabrasive Inc. warrants to the ultimate purchaser and each subsequent purchaser that the equipment is:

Designed, built and equipped so as to conform with all applicable regulations; and

Free from defects in materials and workmanship that cause the failure of a warranted part to be identical in all material respects to that part as described in Superabrasive Inc. application for certification.

The warranty period begins on the date the equipment is delivered to an ultimate purchaser or first placed into service. The warranty period is two years.

Subject to certain conditions and exclusions as stated below, the warranty on emission-related parts is as follows:

(1) Any warranted part that is not scheduled for replacement as required maintenance in the written instructions supplied, is warranted for the warranty period stated above. If the part fails during the period of warranty

coverage, the part will be repaired or replaced by Superabrasive Inc. according to subsection (4) below. Any such part repaired or replaced under warranty will be warranted for the remainder of the period.

(2) Any warranted part that is scheduled only for regular inspection in the written instructions supplied is warranted for the warranty period stated above. Any such part repaired or replaced under warranty will be warranted for the remaining warranty period.

(3) Any warranted part that is scheduled for replacement as required maintenance in the written instructions supplied is warranted for the period of time before the first scheduled replacement date for that part. If the part fails before the first scheduled replacement, the part will be repaired or replaced by Superabrasive Inc. according to subsection (4) below. Any such part repaired or replaced under warranty will be warranted for the remainder of the period prior to the first scheduled replacement point for the part.

(4) Repair or replacement of any warranted part under the warranty provisions herein must be performed at a warranty station at no charge to the owner.

(5) Notwithstanding the provisions herein, warranty services or repairs will be provided at all of our distribution centers that are franchised to service the subject engines or equipment.

(6) The SORE owner will not be charged for diagnostic labor that is directly associated with diagnosis of a defective, emission-related warranted part, provided that such diagnostic work is performed at a warranty station.

(7) Superabrasive Inc. is liable for damages to other engine or equipment components proximately caused by a failure under warranty of any warranted part.

(8) Throughout the SORE warranty period stated above, Superabrasive Inc. will maintain a supply of warranted parts sufficient to meet the expected demand for such parts.

(9) Any replacement part may be used in the performance of any warranty maintenance or repairs and must be provided without charge to the owner. Such use will not reduce the warranty obligations of Superabrasive Inc.

(10) Add-on or modified parts that are not exempted by the Air Resources Board may not be used. The use of any non-exempted add-on or modified parts by the ultimate purchaser will be grounds for disallowing a warranty claim. Superabrasive Inc. will not be liable to warrant failures of warranted parts caused by the use of a non-exempted add-on or modified part.

WARRANTED PARTS

The repair or replacement of any warranted part otherwise eligible for warranty coverage may be excluded from such warranty coverage if Superabrasive Inc. demonstrates that the SORE has been abused, neglected, or improperly maintained, and that such abuse, neglect, or improper maintenance was the direct cause of the need for repair or replacement of the part. That notwithstanding, any adjustment of a component that has a factory installed, and properly operating, adjustment limiting device is still eligible for warranty coverage. The following emission warranty parts are covered:

(1) Catalytic converter

(2) Fuel system: Carburetor, pressure regulator and fuel lock off

(3) Ignition system

(4) Intake system including pre-filter

(5) Exhaust manifold

12. SPARE PARTS

ASSEMBLY AND PARTS SPECIFICATIONS

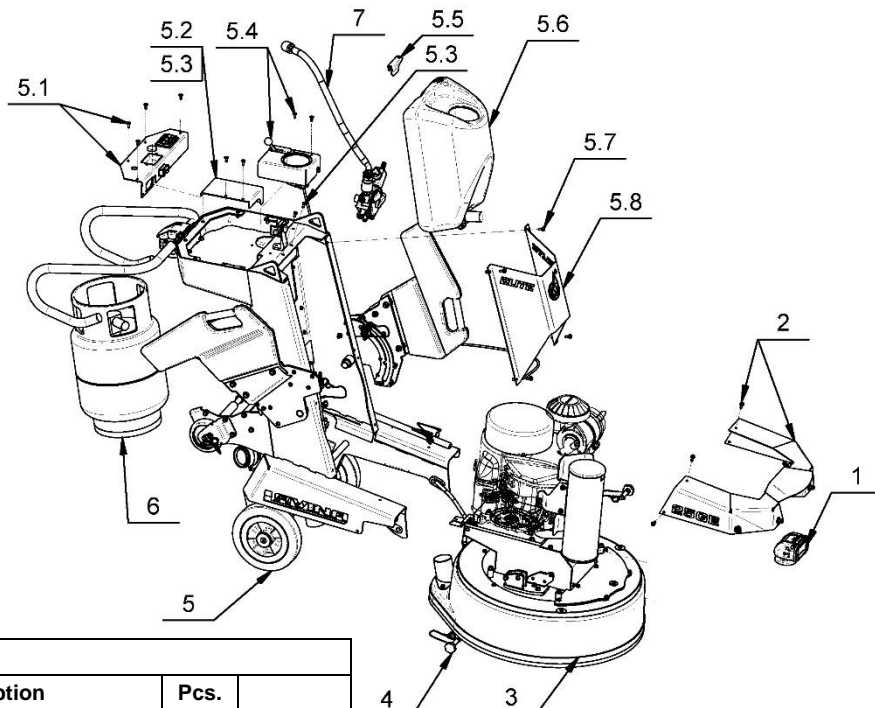

1. LAVINA® 25GE GENERAL PARTS				
No.	Item No.	Description	Pcs.	
1	A50.00.00.00	LED light with magnetic base	1	
2	L25GE01.00.00	Bumper	1	
3	L25GE10.00.00-3	Main Head	1	
4	L25SPS-07.03.00.00	Pin Assembly	2	
5	L25GE20.00.00-2	Carriage	1	
	5.1	L20GX-40.10.00	Control Board	1
	5.2	L20GX-20.00.13	Cover	1
	5.3	30301230243	Screw M6x16ISO7380F/10.9/	4
	5.4	L20GX-40.20.00	Control Board With throttle cable	1
	5.5	L20E20.10.00	Top Bracket	1
	5.6	A62.00.00.00	Tank Assembly	1
	5.7	30301210051	Bolt M6X16DIN6921	4
	5.8	L25E20.50.00	Front panel	1
6	W2504	Propane Tank	1	
7	L20GX-06.00.00	Regulator set	1	
7*	L20GX-06.00.00-1	Regulator set	1	

*The changes are for machines with Serial No 1910L25GE1489 and bigger.

2. LAVINA® 25GE BUMPER			
No.	Item No.	Description	Pcs.
1	L25GE01.00.01-K	Bumper right part	1
2	L25GE01.00.02	Bumper left part	1
3	L20GX-01.00.03	Bumper middle part	1
4	L20GX-01.10.02	Insert for Misting nozzle	4
5	30313000064	Misting nozzle	4
6	30313000343	EQUAL TEE - 1/4 INC - 1/4 INC	3
7	30313000344	Adapter 1/4 INC - NPT1/4	3
8	30301240015	Nut M20x1.5DIN439-B	4
9	30313000348	Fixed Elbow NPT Thread	1
10	025X130	PE Tube	2
11	025X300	PE Tube	1
12	30301240103	Nut M6DIN985	6
13	30308000412	Clamp	2
14	30301210048	Bolt M6X12DIN6921	10

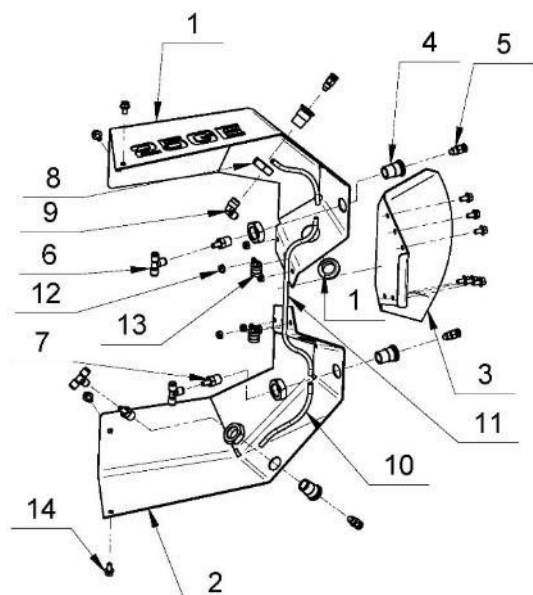

3. LAVINA® 25GE CONTROL BOARD

No.	Item No.	Description	Pcs.
1	30301230243	Screw M6x16ISO7380F/10.9/	4
2	30301230247	Screw M4X30ISO7380F/10.9/	2
3	30313000069	Start Switch	1
4	30313000074	Light Switch	1
5	30313000073	Water Switch	1
6	30313000072	Clutch Switch	1
7	30313000173	Charger	1
8	30301240130	Distance Bush	2
9	GT-EM40	Complete Monitor Assembly	1
10	30301221001	WasherM4DIN125A	2
11	30301240114	Nut M4DIN985	2
12	30311000753	Fuse Holder	1
13	30313000253	Fuse	1
14	30311000719-K	Emergency stop button	1

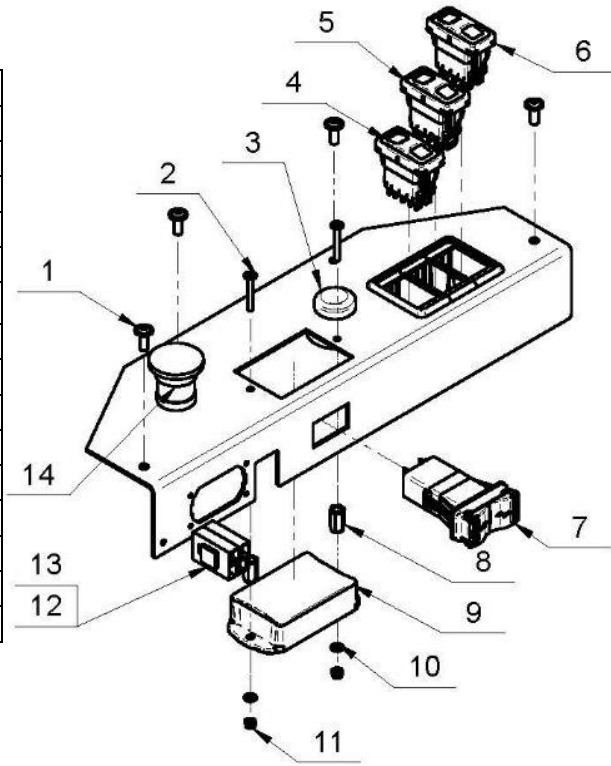

4. LAVINA® 25GE CONTROL BOARD WITH THROTTLE CABLE

No.	Item No.	Description	Pcs.
1	30301230066	SCREW M4X12DIN967	2
2	30313000071	Throttle cable	1
3	L20GX-40.21.00	Based on a Throttle cable	1
4	30301230243	Screw M6x16ISO7380F/10.9/	2
5	30350000045	Cup holder	1
6	L20GX-40.20.03	Clamp	1

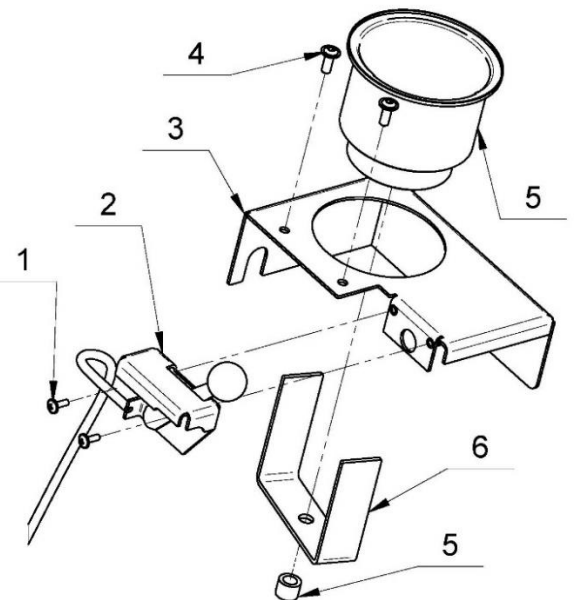

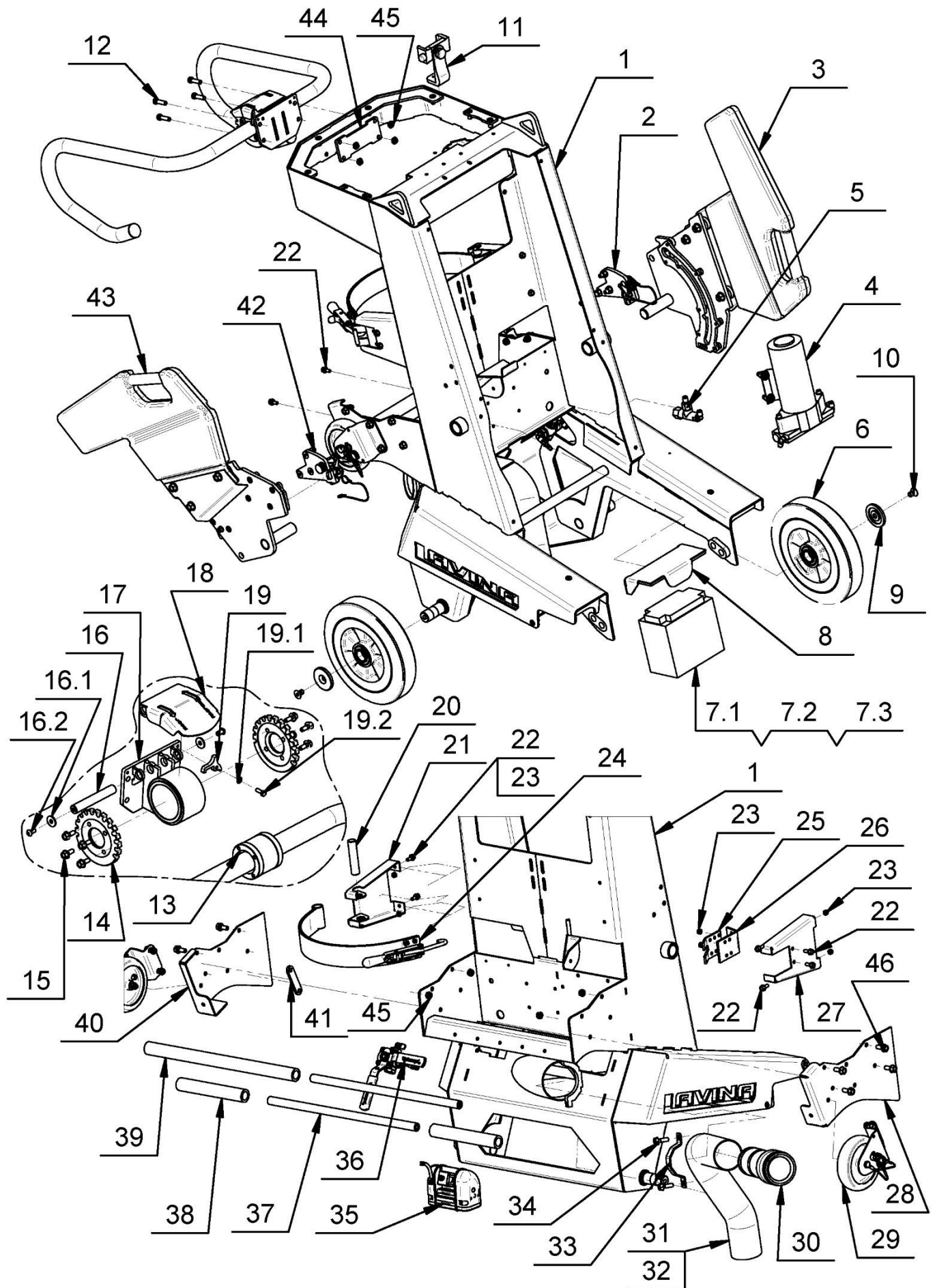

5. LAVINA® 25GE CARRIAGE									
No.		Item No.	Description	Pcs.	No.		Item No.	Description	Pcs.
1		L25GE21.00.00-1-K	Frame	1	22		30301210051	Bolt M6x16DIN6921	8
2		L20GX-20.40.00	Left Weight Support	1	23		30301240103	Nut M6DIN985	8
3*		L20GX-20.20.00	Left Weight	1	24		L20GX-25.10.00	Strap	1
3		L25GE20.20.00	Left Weight	1	25		L20GX-25.30.00	Strap	1
4		A48.00.00.00	Water pump with connectors	1	26		L20GX-25.00.02	Plate for strap holder	1
5		A49.00.00.00	Regulator for Water pump with connectors	1	27		L20GX-25.00.01	Strap holder right	1
6		30312000043	Wheel	2	28		L20GX-20.00.21-2	Support right	1
7	7.1	30313000220	12V Battery	1	29		L25E20.60.00	Wheel Assembly	2
	7.2	30313000062	Wire Connector	1	29*		L25E20.60.00-K	Wheel Set	1
	7.3	30313000061	Wire Connector	1	30		E250-AL	Camlock Fitting	1
8		L20GX-20.70.00	Battery Cover	1	31		D63X470PU	Soft Vacuum Hose	1
9		L25X-20.00.03-1	Wheel Cap	2	32		30308000399	Clamp 50_70DIN3017	1
10		30301230015	Screw M10x16DIN7991/10.9/	2	33		L25GE20.00.02	Clamp	1
11		HGP270	Phone clip mount	1	34		30301210032	Bolt M8X35DIN6921	2
12		30301230257	Screw M8x30DIN7984	4	35		UT-BS0201	LED Light	1
13		L13GX21.10.00	Handle Assembly	1	36*		A47.00.00.00	Water Valve assembly	1
14		L20GX-23.00.01	End Cover	2	36		A47.00.00.00-1	Water Valve assembly	1
15		30301210051	Bolt M6x16DIN6921	8	37		L20GX-20.00.09	Link	2
16		L20GX-23.00.02-1-K	Pin	1	38		L20GX-20.00.28	Rubber support 2	2
	16.1	30301221012	Washer M6DIN9021	2	39		L20GX-20.00.27	Rubber support 1	1
	16.2	30301230250	Screw M6x12ISO7380-1/10.9/	2	40		L20GX-20.00.22-2	Support left	1
17		L20GX-23.30.00	Handle support	1	41		L20GX-20.00.23	Plate	2
18		L20GX-23.20.00	Handle locking bit	1	42		L20GX-20.30.00	Right Weight Support	1
19		L20GX-23.00.11-K	Lock Lever	1	43*		L20GX-20.10.00	Right Weight	1
	19.1	30301210109	Bolt M5x14DIN933	1	43		L25GE20.10.00	Right Weight	1
	19.2	30301221002	Washer M5DIN125A	1	44		L20GX-23.00.03	Handle support plate	1
20		L20GX-25.00.03	Strap axle	1	45		30301240106	Nut M8DIN985	8
21		L20GX-25.20.00	Strap holder left	1	46		30301210031	Bolt M8x20DIN6921	8

* For machines before Serial No 2001L25GE1630

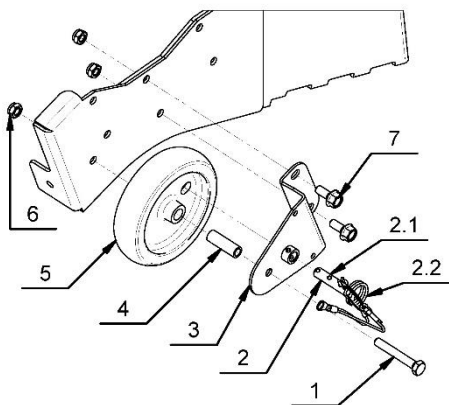

6. LAVINA® 30GE WHEEL ASSEMBLY				
Item No. L25E20.60.00				
No.		Item No.	Description	Pcs.
1		30301210005	Bolt M8X55DIN933	1
2		L25E20.62.00	Pin Assembly	1
	2.1	L25E20.62.02	Pin	1
	2.2	L25E20.62.00-K	Accessories	1
3		L25E20.61.00	Housings	1
4		L25E20.60.03	Bushing	1
5		L25E20.60.01	Wheel	1

7. LAVINA® 25GE WATER PUMP

No.	Item No.	Description	Pcs.
1	3032600003	Pump	1
2	30313000348	Fixed Elbow NPT Thread	2
3	30313000056	Male Hex Plug	1
4	30301240090	Nut M5DIN985	4
5	30301221015	Washer M5DIN9021	4
6	30301230113	Screw M5X25DIN84A	4
7	30313000341	Stud Fitting	1

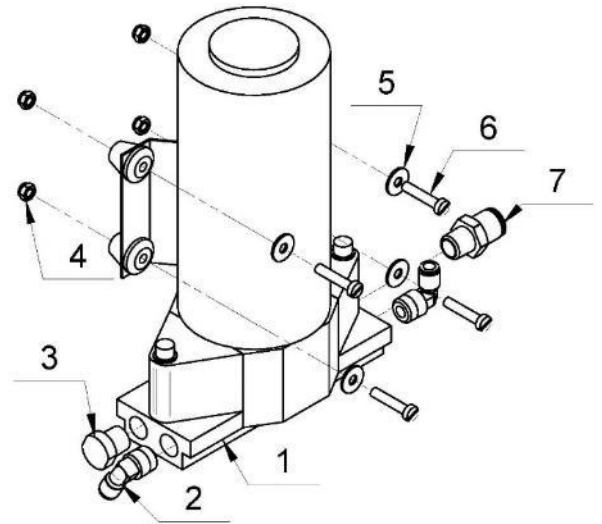

8. LAVINA® 25GE WATER BALL VALVE

Item No. A47.00.00.00

NO.	ITEM NO.	DESCRIPTION	PCS.
1	30316000066	Ball valve	1
2	30301230098	Screw M6x16DIN 912	1
3	30301210110	Bolt M5x16DIN6921	1
4	30313000348	Fixed Elbow NPT Thread	3
5	30301240103	Nut M6DIN985	1
6	30313000057	UNIJET Body	1
7	30313000058	TEEJET Cup Strainer	1
8	A47.00.00.01	Orifice Plate	1
9	30313000060	UNIJET ADAPTER	1
10	30313000339	Tube To Hose Stem	1

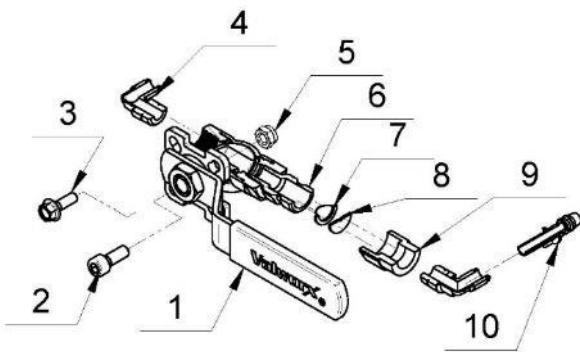

8.1. LAVINA® 25GE WATER BALL VALVE

Item No. A47.00.00.00-1

No.	Item No.	Description	Pcs.
1	30316000066	BALL VALVE	1
2	30301230098	SCREW M6X16DIN 912	1
3	30301210110	BOLT M5X16DIN6921	1
4	30313000348	FIXED ELBOW NPT THREAD	3
5	30301240103	NUT M6DIN985	1
6	30313000339	TUBE TO HOSE STEM	1

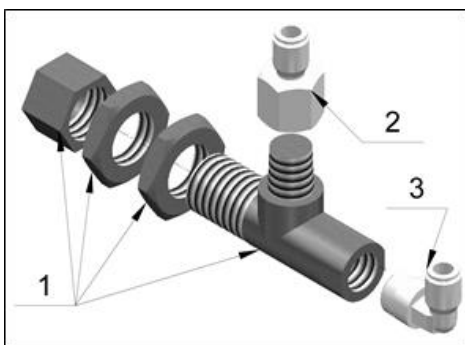
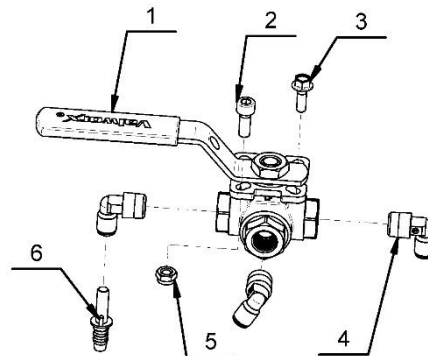

9. LAVINA® 25GE WATER PUMP REGULATOR

No.	Item No.	Description	Pcs.
1	30313000055	Water Pump Regulator	1
2	30313000349	FEMALE STUD FITTING	1
3	30313000348	Fixed Elbow NPT Thread	1

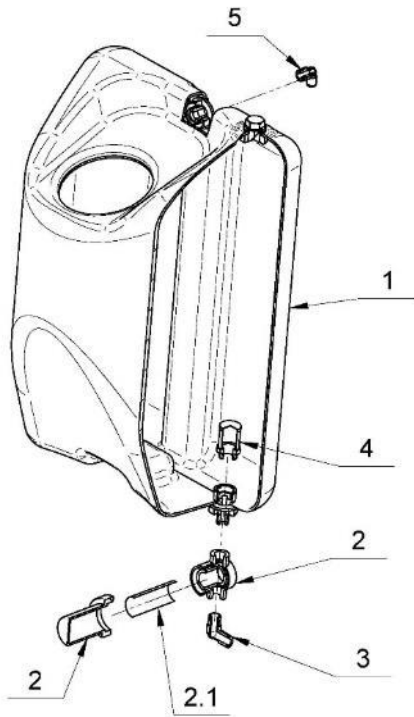

10. LAVINA® 25GE WATER TANK				
No.	Item No.	Description	Pcs.	
1	A62.00.00.01-K	Water Tank-K	1	
2	30323000209	Filter_LP 1/4 FNPT GFPP CB 80X80 SST CG BN	1	
2.1	30313000077	Filter	1	
3	30313000342	Fixed Elbow Male NPTF Thread -3/8 INC- NPT1/4	1	
4	30316000001	Filter	1	
5	30313000348	Fixed Elbow NPT Thread	1	

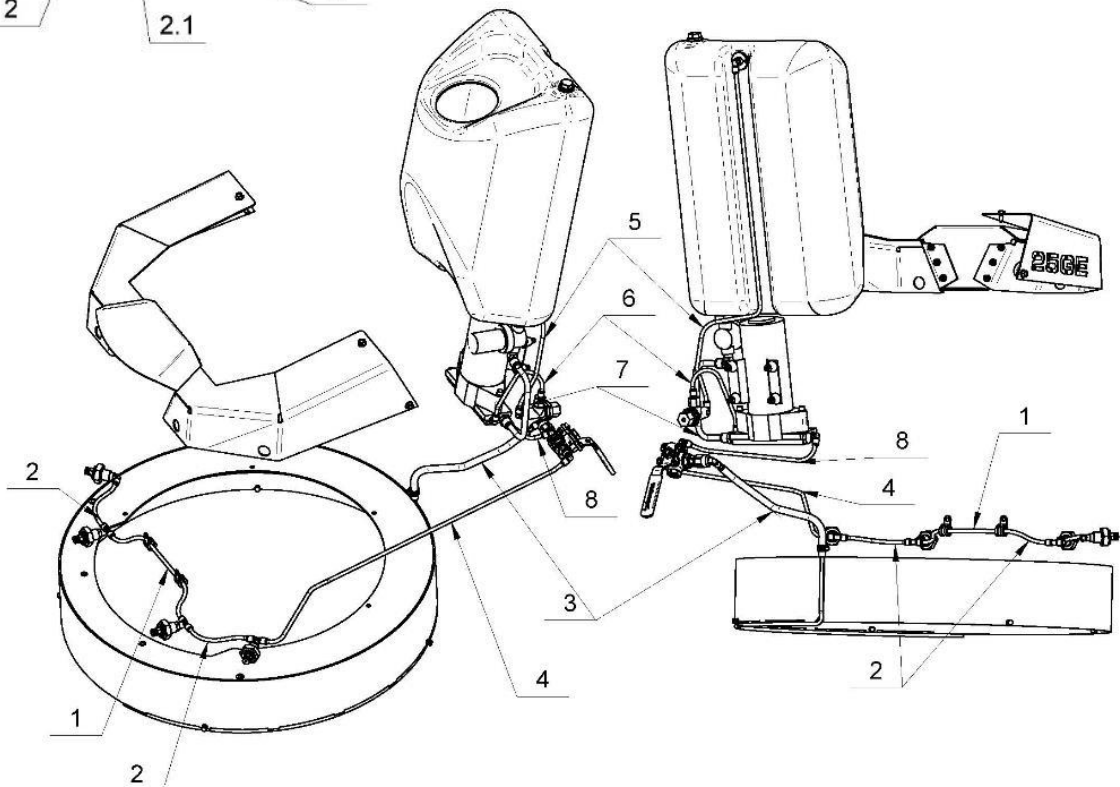

11. LAVINA® 25GE WATER INSTALLATION				
No.		Item No.	Description	Pcs.
1	See table 2 "BUMPER"	025X300	PE Tube	1
2		025X130	PE Tube	2
3	See table 14 "TOP COVER ASSEMBLY"	L20GX-19.00.05	Tube	1
4	Ball valve - Bumper	025X730	PE Tube	1
5	Regulator – Water tank in	025X730	PE Tube	1
6	Pump out - Regulator	025X300	PE Tube	1
7	Pump in – Water tank out	038X500	PE Tube	1
8	Pump out - Ball valve	025X300	PE Tube	1

12. LAVINA® 25GE ENGINE BASE PARTS				
No.	Item No.	Description	Pcs.	
1	KFX600	Complete Engine Assembly	1	
2	L25GS-10.02.06	Clutch Washer	1	
2*	L25GE10.02.06	Clutch Washer	1	
3	5215	Electric Clutch	1	
3*	47621932	Electric Clutch	1	
4	L25G-10.02.02.S	Bolt Set	1	
4*	L25GE10.02.02 S	Bolt Set	1	
5	30301210038	Bolt M8X25DIN6921	4	
6	30301210048	Bolt M6X12DIN6921	4	
7	L20GX-10.00.96	Carrier	1	
8	L20GX-10.00.97	Guard Oil Drain Valve	1	
9	SAB-3/8-16X1-1/4	Bolt	4	
10	L25G-10.00.66	Tensioning Device Support	1	
11	30301230004	Screw M8X25DIN912	2	
12	30308000106	Endless Transmission Belt	1	
13	L25E10.70.00	Gard Assembly	1	
14	30301210004	Bolt M8X40DIN933	1	
15	30301221004	Washer M8DIN125A	1	
16	30301210051	Bolt M6X16DIN6921	8	
17	L25G-10.05.00-1	Back Guard	1	
18	L25GX-10.00.69	Front Guard	1	
19	30301210072	Bolt M8X16DIN6921	2	
20	30301221022	Washer D35x1.4	2	
21	30301220022	Spring Washer M8DIN7980	2	

*For machines after Serial № 2001L25GE1630

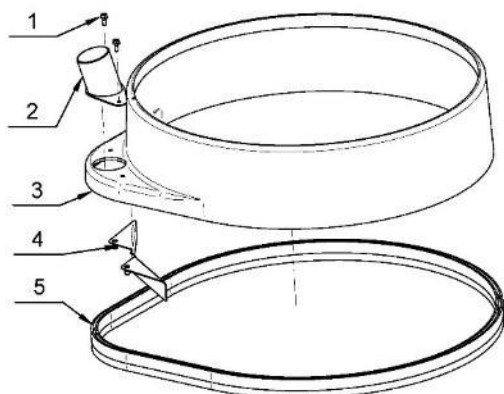
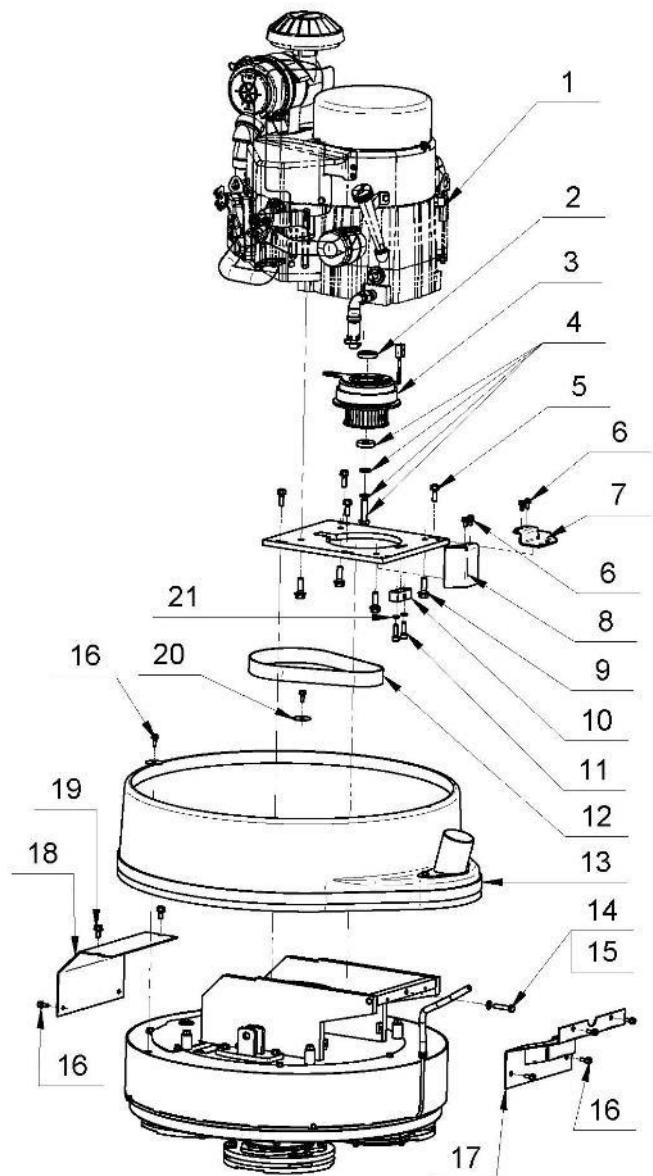

13. LAVINA®25GE GARD ASSEMBLY			
No.	Item No.	Description	Pcs.
1	30301210117	Bolt M6X20DIN6921	2
2	L30E10.71.00	Vacuum Port	1
3	L25GE10.70.01	Guard	1
4	L25E10.71.00	Bottom Vacuum Port	1
5	FBL1350-2280	Brush	1

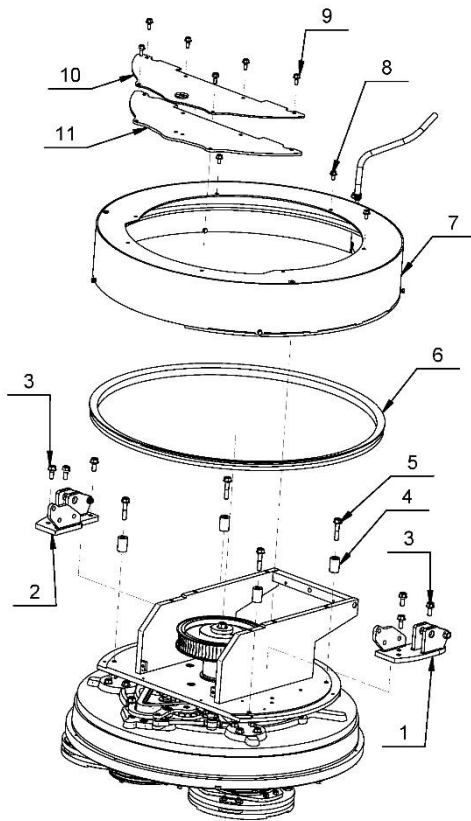

14. LAVINA®25GE TOP COVER

No.	Item No.	Description	Pcs.	
1	L20GX-18.10.00	Left Fork	1	
1*	L25GE02.30.00	Left Fork	1	
2	L20GX-18.20.00	Right Fork	1	
2*	L25GE02.40.00	Right Fork	1	
3	30301210031	Bolt M8X20DIN6921	6	
4	L20GX-15.00.29	Bushing	4	
5	30301210092	Bolt M8X40DIN6921	4	
6	30302000049	V-Ring Type A	1	
7	L25E19.00.00-1	Top Cover Assembly	1	
8	30301210048	Bolt M6X12DIN6921	3	
9	30301210051	Bolt M6X16DIN6921	6	
10	L25GE19.20.00-2	Inspection Cover	1	
11	L25GE10.00.99-1	Sealer Inspection Cover	1	
For machines before Serial No 2001L25GE1630				
10 and 11		L25GE19.20.00-2-K	Inspection Cover	1
	10.1	L25GE19.20.00-2	Inspection Cover	1
	10.2	L25GE10.00.99-1	Sealer Inspection Cover	1
	10.3	30301210051	Bolt M6X16DIN6921	6

*The changes are for machines with Serial No 2001L25GE1630 and bigger

15. LAVINA®25GE TOP COVER ASSEMBLY			
No.	Item No.	Description	Pcs.
1	L25E19.10.00-1	Top Cover	1
2	30301210007	Bolt M5X10DIN933	4
3	30301220001	Spring Washer M5DIN127B	4
4	30308000419	Clamp	1
5	L20GX-19.00.05	Tube	1

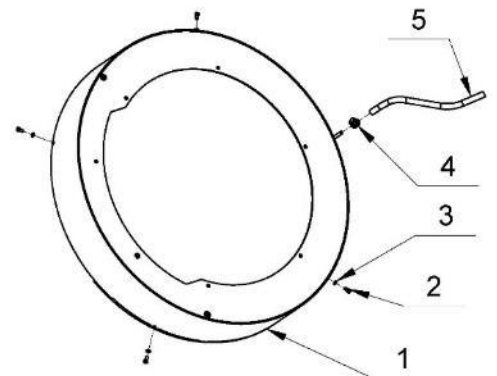

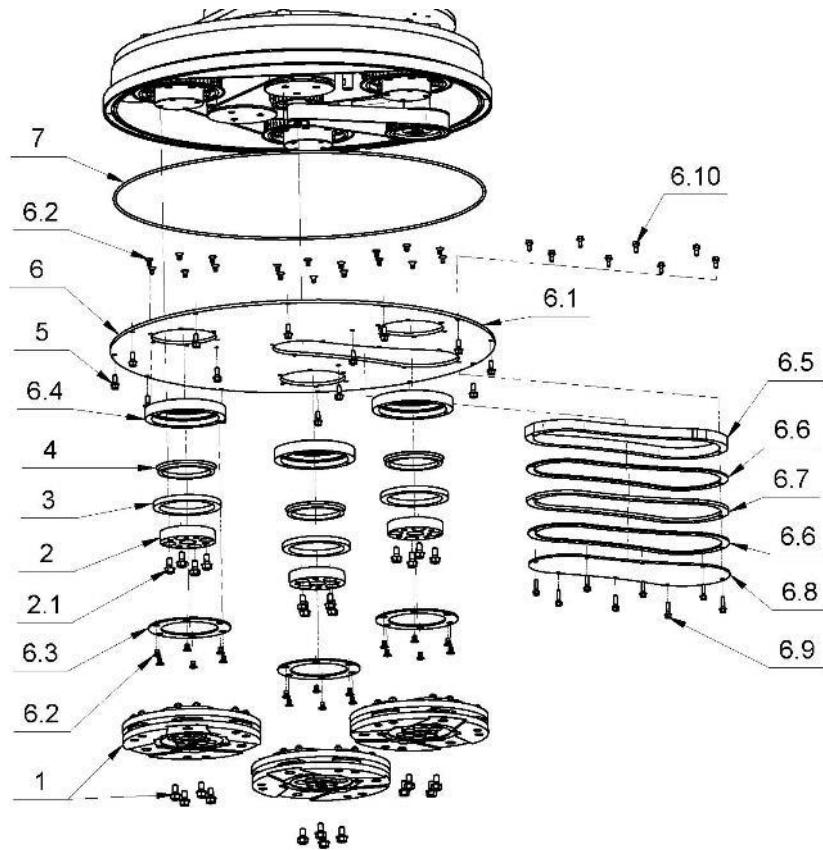

16. LAVINA® 25GE BOTTOM COVER 1 PARTS				
No.		Item No.	Description	Pcs.
1		A63.00.00	Tool Holder A63	3
2		A42.03.00	Adaptor	3
	2.1	30301210072	Bolt M8x16DIN6921	4
3		30309000000	Felt Ring	3
4		30302000005	V-Ring Type A	3
5		30301210051	Bolt M6x16DIN6921	15
6		L25X-14.00.00-R2	Bottom Cover Assembly	1
	6.1	L25X-14.00.01	Bottom Cover	1
	6.2	30301230017	Screw M6X10DIN7991/10.9/	36
	6.3	L25LS-14.00.03	Outer Cover	3
	6.4	L25LS-14.00.02	Flange	3
	6.5	L25X-14.00.05	Flange	1
	6.6	L25X-14.00.04	Sealer Inspection Cover	2
	6.7	L25X-14.00.06	Pad 2	1
	6.8	L25X-14.10.01-R2	Inspection Cover	1
	6.9	30301210105	Bolt M5X20DIN6921	8
6.10	30301210030	Bolt M5X12DIN6921	8	
7		D4X2X1900	Seal	1

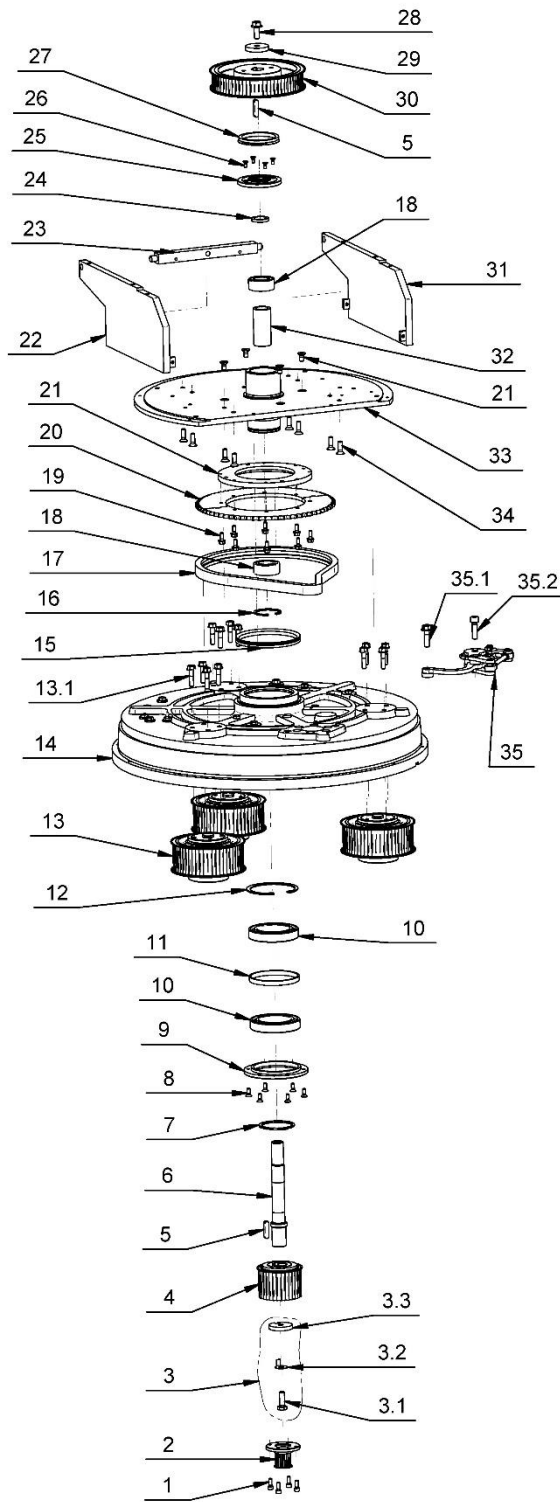

17. LAVINA® 25GE PLANETARY DRIVE PARTS				
No.	Item No.	Description	Pcs.	
1	30301230098	Screw M6X16DIN912	4	
2	L25X-03.00.00-R2	Pulley	1	
3	L25E10.00.03-K	Front Washer Assembly	1	
	3.1	30301210059	Bolt M10X30DIN933	1
	3.2	L25E10.00.05	Washer	1
	3.3	L25E10.00.03	Front Washer	1
4	L25GX-10.10.00	Central Pulley	1	
5	30301260057	Key	2	
6	L25GX-10.00.57-1	Shaft	1	
7	30301250002	Retaining Ring	1	
8	30301230002	Screw M6x16DIN7991/10.9/	6	
9	L25X-10.00.17	Cap	1	
10	30303000012	Roller Assembly	2	
11	L25SPS-00.00.00.34	Distance Ring	1	
12	30301250009	Retaining Ring	1	
13	L25X-11.00.00	Pulley Unit Assembly	3	
	13.1	30301210032	Bolt M8X35DIN6921	4
14	L25E10.00.01-K	Disc	1	
15	30302000008	V-Ring Type A	1	
16	30301250007	Retaining Ring	1	
17	08BH-1-78	Chain	1	
18	30303000024	Roller Assembly	2	
19	30301210051	Bolt M6X16DIN6921	8	
20	L25X-15.00.12	Chain Pulley	2	
21	L25X-15.00.03-K	Flange	1	
22	L25GX-15.04.00	Right Plate Assembly	1	
23	L25G-10.00.64	Support Plate	1	
24	L25G-10.00.59	Insert	1	
25	L20GX-15.00.07	Cap for Rotary Seal	1	
26	30301230025	Screw M5X12DIN7991/10.9/	4	
27	30302000004	V-Ring Type A	1	
28	30301210096	Bolt M10X25DIN6921	1	
29	L25GX-10.00.55	Front Washer	1	
30	L25GX-10.30.00	Pulley Unit	1	
31	L25GX-15.03.00	Left Plate Assembly	1	
32	L20GX-15.00.05	Bushing	1	
33	L25GE15.20.00	Base plate	1	
34	30301230027	Screw M8X25DIN7991/10.9/	8	
	L25X-17.00.00	Chain Tensioner	1	
	35.1	30301210021	Bolt M10X35DIN6921	1
	35.2	30301230007	Screw M10x35DIN912	1

17.1. LAVINA® 25GE PULLEY UNIT ASSEMBLY				
No.	Item No.	Description	Pcs.	
1	L25E10.00.02-K	Front Washer Assembly	1	
	1.1	30301210035	Bolt M5X12DIN933	1
	1.2	L25E10.00.04	Washer	1
	1.3	L25E10.00.02	Front Washer	1
2	L25E16.20.00-1	Chain Pulley Assembly	1	
3	30302000032	V-Ring Type A	1	
4	L25X-16.00.00-R3	Bearing Body	1	
	4.1	30301210107	Bolt M6X25DIN6921	6
	4.2	30301260060	Key	2
	4.3	L25X-16.00.03-1	Distance Ring	1
5	L25X-04.00.00	Pulley Unit Assembly	1	
6	L25X-10.00.44	Front Washer	1	
7	30301230009	Screw M5X12DIN912	1	

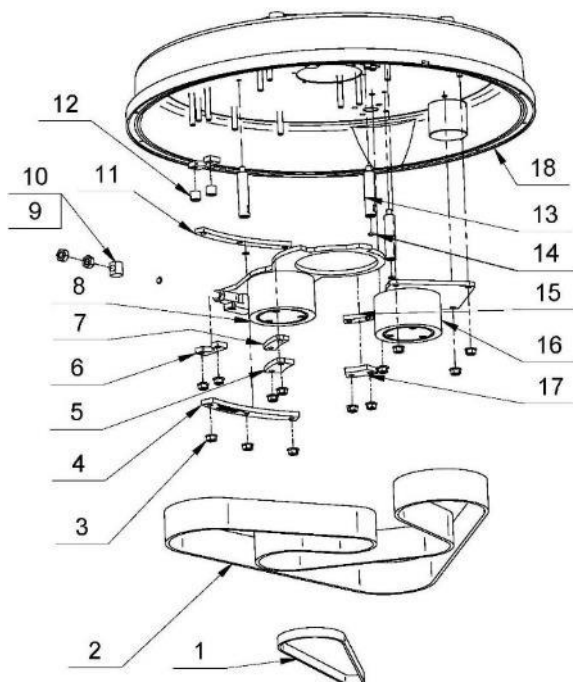
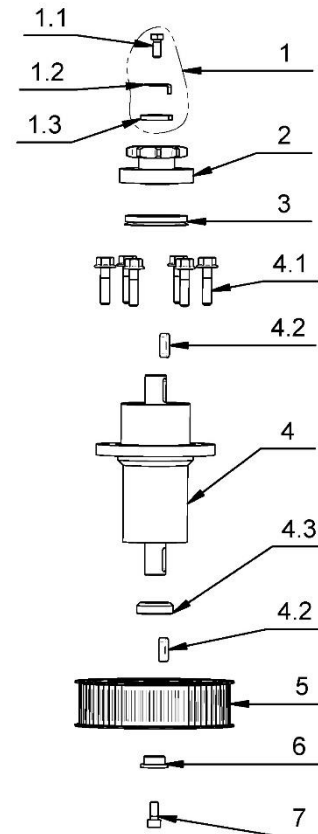

18. LAVINA® 25GE BOTTOM COVER 2 PARTS				
No.	Item No.	Description	Pcs.	
1	30308000152	Timing Belts	1	
2	30308000130	Timing Belts	1	
3	30301240095	Nut M8DIN6923	13	
4	L25L-10.00.14	Sector	1	
5	L25L-10.00.12	Sector	1	
6	L25L-10.00.07	Support	2	
7	L25L-10.00.11	Sector	1	
8	L25E12.00.00	Tensioning Support	1	
9	L32C-14.20.04	Nut	1	
10	30301240099	Nut M10DIN934	2	
11	L25L-10.00.13	Sector	1	
12	L25L-10.00.08	Washer	2	
13	L25X-10.00.13	Distance Bolt	3	
14	30302000105	O-Ring	3	
15	L25X-10.00.34	Sector	1	
16	L25E13.00.00	Deflection Pulley	1	
17	L25X-10.00.35	Sector	1	
18	L25E10.00.01-K	Disc	1	

19. LAVINA®25GE TOOL HOLDER PARTS/SEE ALSO FIG.8.7.13/ (POS.1 INCLUDE POS.1.1;1.2;1.3/POS.1.3 INCLUDE POS.1.3.1 and etc.)				
No.		Item No.	Description	Pcs.
1		A63.10.00	Quick Change Assembly	1
	1.1	A63.12.00	Keylock Set	1
	1.2	A41.11.00	Quick Change plate	1
	1.3	A41.12.00	Security set	1
	1.3.1	A41.00.05	Washer A41	1
2		A25.00.10-K	Buffer with two screw	6
	2.1	30301230161	Screw M8X12DIN7991/10.9/	12
	2.2	A25.00.10	Buffer	6
3		A41.20.03-K	Driving Set A41	1
	3.1	A41.20.03	Elastic Element	1
	3.2	30301240124	Self Locking Nut M6DIN980V	12
	3.3	30301230123	Screw M6X30DIN7991/10.9/	6
	3.4	30301230131	Screw M6X40DIN7991/10.9/	6
	3.5	A41.21.00	Set of plates	1
4		30301210072	Bolt M8x16DIN6921	4
5		A41.20.01	Flange	1

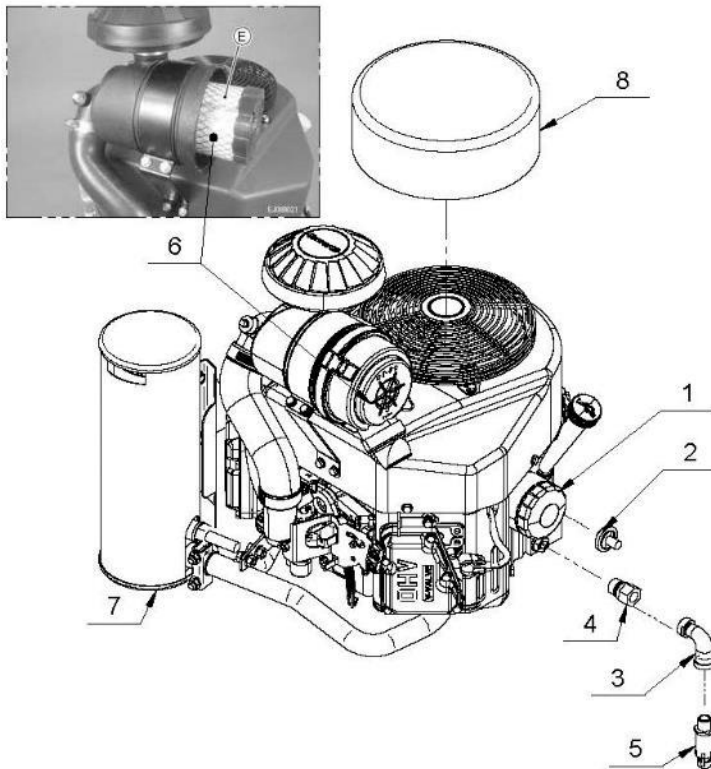
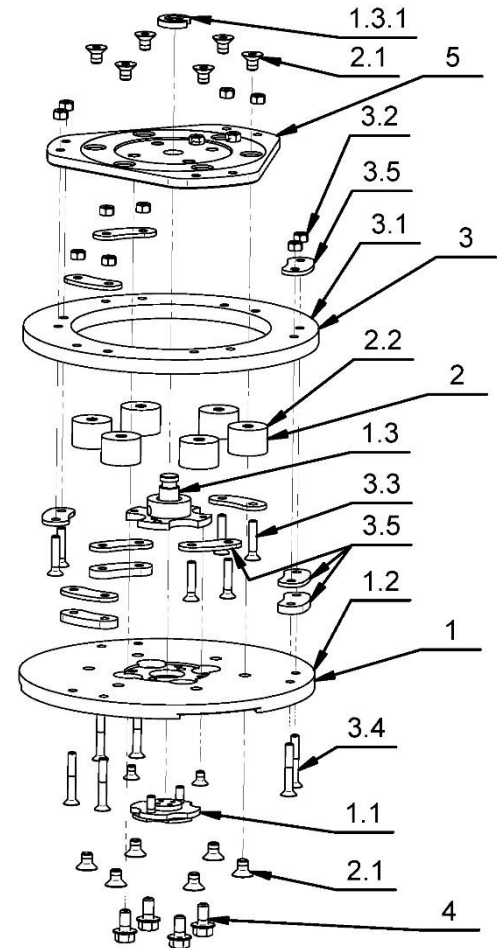

LAVINA® 25GE KAWASAKI FX600V ENGINE PARTS			
No.	Item No.	Description	Pcs.
	KFX600	Complete Engine Assembly	
1	K49065-7007	Oil Filter	1
2	106	Oil Pressure Switch	1
3	120	Elbow	1
4	123	Joint	1
5	109	Oil Drain Valve	1
6	125	Element Air Filter	1
7	K201	Vertical Cat Muffler Assy.	1
8	117	Bonnet Filter	1

LAVINA® 25GE OPTION			
No.	Item No.	Description	Pcs.
1	L25GE02.20.00-K	Lever Assembly	1
2	L25GE02.10.00-K	Lever mount	1
3*	L25GE02.00.00	Lever Set	1

*-For machines before Serial № 2001L25GE1630

