



  
Husqvarna®



ENG

# 390

Operator's Manual

Read these instructions carefully and make sure you understand them before using the 390.

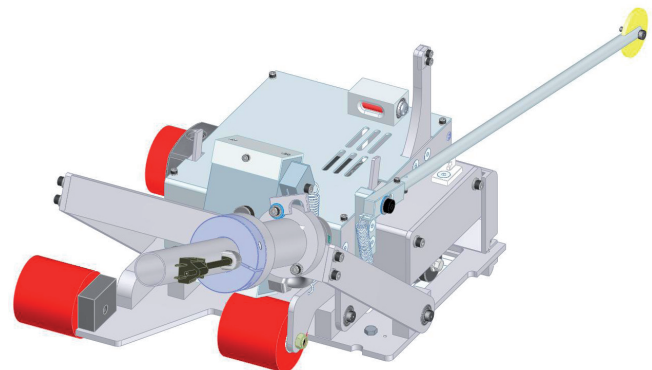

---

## CONTENTS

---

Content	Page
Table of contents .....	2
Unpacking .....	2
Transporting .....	2
Introduction, personal safety .....	3
Registration of the product .....	4
General safety message .....	4
Safety warnings .....	5
Excel series blades .....	6
Blade and skid plate installation .....	6
What is what? .....	7
Operating instructions .....	8
Grounding instructions .....	9
Extension cords and generators .....	9
Maintenance .....	9
Maximizing the Soff-Cut system .....	10
Sawing contraction joints .....	11
Troubleshooting .....	12
Technical specifications .....	13
Conformity certificates .....	13
Warranty .....	14

---

## UNPACKING

---

Your **390 electric** saw has been shipped from the factory thoroughly inspected. The durable travel case contains the **390** saw, a blade shaft wrench, an owner's manual, a part list, a warranty card, a pack of thumb nuts, and a joint protector sample pack.

---

## TRANSPORTING

---

The **390 electric** saw weights approximately 30 pounds (14 kilograms) when ready to use . Use safe handling practices when using the saw. Immediately clean the blade guard housing after each and every use to prevent concrete dust buildup. Always remove the diamond blade when transporting the saw. Fold the guide arm back and unscrew the handle from the housing prior to storing in the carrying case.



---

# INTRODUCTION

---

The **390** electric saw is designed as a residential and light commercial Ultra Early Entry concrete saw and is one of the smallest and lightest saws in the Husqvarna Soff-Cut line. The patented Soff-Cut Ultra Early Entry dry cutting system controls random cracking of concrete through the early timing of the saw cutting usually within one to two hours after the finishing process is completed. The patented saw and skid plate technology in conjunction with Husqvarna Excel Series blades allows for Ultra Early Entry sawing the same day while minimizing chipping and spalling. The saw is a manual push style with manual controls for all functions.

## Common sense:

The focus of this manual is HOW to operate and service the equipment safely.

It is not possible to cover every conceivable situation you can face when using this equipment. Therefore use this product only in a manner described in this manual. Operation or handling the machine in any other manner can lead to serious injury or death.

If a situation is not described in this manual it should be considered dangerous - and not be done.

If you are unfamiliar with this product make sure that you carefully understand how it functions and practice all operations and handling before putting the machine to use. Familiarize yourself in the presence of an experienced operator. Avoid all situations that are beyond your capability.

If you still feel uncertain about the operating procedures after reading these instructions DO NOT operate the machine until you have consulted an experienced operator.

If you have further questions you can contact the closest Husqvarna Construction Products location by writing or calling, see information below. You can also find the closest location by searching the internet at; **www.husqvarnacp.com** . Husqvarna Construction Products will willingly be of service and provide you with advice as well as help you to use your product both efficiently and safely.

Additional manuals are available at NO CHARGE and can also be obtained on the internet site.

Husqvarna Construction Products  
265 Radio Road  
Corona, California 92879  
USA

**Toll Free no:** 800 776 3328 (USA & Canada)  
**Phone no:** 951 272 2330  
**Telefax no:** 951 272 2338

Internet Site: **www.husqvarnacp.com**

---

## PERSONAL SAFETY EQUIPMENT

---

When working and operating the saw the following approved personal safety items should be used:



Head Protection



Hearing Protection



Eye Protection



Safety Shoes



Protective Gloves

---

# REGISTER THE PRODUCT

---

Please register your new **390** with Husqvarna Construction Products by mailing in the registration card that came with the machine or you can register on the internet site [www.husqvarnawarranty.com](http://www.husqvarnawarranty.com)

Registration will allow us to contact in case of any critical updates or recalls on this machine. Warranty registration has also been found to be helpful in tracing stolen equipment.

Record the following information for your records:

PURCHASE DATE: \_\_\_\_\_

MODEL No: \_\_\_\_\_

SERIAL No: \_\_\_\_\_

ENGINE MODEL: \_\_\_\_\_ ENGINE TYPE: \_\_\_\_\_ ENGINE CODE: \_\_\_\_\_

*The 390 serial number as well as the engine model number, engine type and code are critical in order to obtain the correct service parts.*

---

## SAFETY DEFINITIONS

---

In this manual a Safety Alert Symbol  followed by the signal words WARNING and CAUTION are used to identify safety information about hazards which can result in death, serious injury and/or property damage.

These signal words mean:

 **WARNING** indicates a hazard which, if not avoided, **could result in death or serious injury.**

 **CAUTION** indicates a hazard which, if not avoided, **might result in minor or moderate injury.**

**NOTICE** indicates a message not related to personal injury.

---

## SAFETY HAZARDS

---

### **WARNING**

#### **DO NOT MODIFY THE PRODUCT**

Under no circumstances may the design of the machine be modified without the permission of the manufacturer. Always use genuine accessories. Unauthorized modifications and/or accessories can result in serious personal injury or the death of the operator or others. Your warranty may not cover damage or liability caused by the use of unauthorized accessories or replacement parts.

### **WARNING**

**CALIFORNIA PROP 65**  
Use of this product can expose you to materials known to the State of California to cause cancer and/or birth defects or other reproductive harm.

### **CAUTION**

**HEARING HAZARD**  
During the normal use of this machine, operator may be exposed to a noise level equal to or higher than 85 dB(A). Use hearing protection.

# SAFETY WARNINGS



## WARNING

Failure to comply with the following warnings could result in serious bodily injury or death!

### WORK AREA SAFETY

- Never operate the saw in any application or job where you are not trained or supervised.
- Keep visitors, children and animals out of the work area.
- Do not operate the saw in areas of combustible material or fumes. Sparks may occur from the saw that could cause a fire or explosion.
- The motor and saw can become hot during operation. Keep all body parts and foreign material away from the electric saw while running.
- Avoid dangerous environments. Do not use the saw in damp or wet locations. Do not expose saw to rain. Keep work area well lit and clean.
- Use only extension cords suitable for outdoor use and marked with suffix W-A or W.
- Before connecting the saw to a power source (receptacle, outlet, etc.) insure the voltage supplied is the same as that specified on the saw nameplate. A power source with voltage greater than specified on the saw can result in serious injury as well as damage to the saw. If in doubt, do not use the saw. Using a power source with voltage less than the saw nameplate is harmful to the motor.
- The saw must be plugged into an outlet properly installed and grounded in accordance with all codes. Never modify the plug in any way. Do not use adaptor plugs. Check with a qualified electrician if you are in doubt.

### BLADE SAFETY

- Examine cutting blades before each use. Do not use any blades that has cracks, nicks, or flaws. Tri-arbor hole should be undamaged. Use only dry cut, steel core, tri-arbor diamond blades made for cutting uncured concrete.
- Husqvarna Excel Series diamond blades is designed to only cut green concrete. Cutting any other material may result in blade failure or a dangerous condition.
- Inspect blade flanges for damage, excessive wear and cleanliness before mounting the blade. The blade should fit snugly on clean, undamaged, tri-arbor shaft.
- Use only Husqvarna Excel, ProEdge Series blades, or blades marked with a maximum operating speed greater than 7,000 rpm.
- Never operate the saw without the blade guard assembly securely in place and skid plate installed in working order. A damaged blade guard assembly must be replaced to protect the operator.
- Avoid getting in direct line with the blade or contacting the blade while it is rotating.

### SAW SAFETY

- Do not leave saw unattended while the electric motor is running.
- Do not alter the saw. Any alteration or modification is misuse and may result in a dangerous condition.
- All safety guards must be in place before starting saw.
- Only operate the saw from behind the machine with both hands on the handle.
- Avoid accidental starting. Be sure switch is "OFF" before plugging in. Do not use saw if switch does not turn it "ON" or "OFF".
- Do not use damaged equipment, blades, guards or personal protection equipment. Do not disable safety equipment or kill switches.
- Use only Husqvarna Construction Products replacement parts. Use of unauthorized parts may create a danger.
- Remove all wrenches from the saw before starting.
- Never stand on the saw.
- When the saw is not in use or transporting, remove the blade and properly secure the saw to prevent accidental movement.
- Disconnect the electric cord to the saw and put the safety switch in off (red) position when not in use, before servicing, and when changing or installing blades.
- Do not abuse the electric cord. Never carry the saw by the cord or yank it to disconnect from the receptacle. Keep cord from heat, oil, or sharp edges. Inspect cord periodically and do not use saw if damaged.

### PERSONAL SAFETY

- Read and understand instructions before operating saw.
- Always wear safety approved hearing, eye, head and respiratory protection.
- Wear boots with non-slip soles to provide proper footing. Steel-toed safety boots are recommended.
- Wear rubber work gloves to avoid contact with wet concrete which can cause serious skin irritation.
- Know how to stop the saw quickly in case of emergency.
- Keep all parts of your body away from blade and other moving parts. Do not wear loose clothing or jewelry which can be caught in moving parts. Wear protective hair covering to contain long hair.
- Stay alert. Maintain awareness of saw operation. Use common sense. Do not operate saw when tired or after consumption of any substance that would impair physical function or rational judgment.
- Do not over reach. Keep proper footing and balance.
- Guard against electric shock. Prevent body contact with grounded surfaces such as pipes, conduit, radiators, etc.

# EXCEL SERIES BLADES

The Excel Series of diamond blades have been designed specifically for the Soff-Cut Ultra Early Entry dry cutting system of green concrete. These specialty blades are designed to increase speed and life while cutting a wide range of aggregates. Choose the correct specification of diamond blade for your area as follows:

Red Excel Series 3000  
Yellow Excel Series 5000  
Blue Excel Series 7000

XL55-3000A  
XL55-5000A  
XL55-7000A

Hard aggregate, medium abrasive sand  
Medium hard to soft aggregate, abrasive sand  
Soft aggregate, highly abrasive sand

## BLADE AND SKID PLATE INSTALLATION



### WARNING

Disconnect the unit from the power source before making any adjustments or changing blade and skid plate.

#### Step 1

With the saw turned off, unplugged from the power source and the safety switch (A) on the handle in the OFF (red) position, push the box release lever (B) on the left side of the saw forward and raise the front of the box.

#### Step 2

With the box fully tilted rearward, rotate the blade by hand while pushing rearward on the arbor lock lever (C) on the right side of the saw. With the blade wrench provided with the saw, loosen the blade bolt (D) on the arbor by turning counter-clockwise. Remove the outer arbor washer or flange (E).



### WARNING

Do not use any blade (F) that has cracks, nicks, flaws or a damaged arbor. Make sure the blade is marked with a maximum operating speed greater than 7,000 rpm. Use only dry cutting concrete diamond blades.

#### Step 3

Match the blade tri-arbor to the blade shaft arbor and install the blade firmly against the rear flange (G). Insure the blade installed on the tri-arbor correctly. Match the female tri-arbor of the outer washer or flange (E) with the blade shaft and install the blade shaft bolt (D) by turning clockwise while holding the arbor lock lever (C). Be sure the outer flange is fully seated and firmly holding the diamond blade (F) in position.

#### Step 4

Install a new skid plate (H) by removing the white thumb nuts (I) on the bottom of the saw. Install the skid plate on the studs by applying pressure on the ends of the skid plate. An alignment pin insures that the plate installs in one direction only. **Do not force the skid plate or apply force in the center of the skid plate as this can bend or warp the skid plate and may cause chipping and raveling of the cut.**

#### Step 5

Install the white thumb nuts (I) to hold the skid plate. Check that the blade aligns with the skid plate slot. When replacing a worn blade, thoroughly clean the concrete from the blade block guard assembly and front diverter before installing the new blade.

A new skid plate is included with every new blade. Make sure to remove and discard the old skid plate and replace it with a new skid plate every time the blade is replaced.

#### NOTE:

The patented skid plate is the most important part of the Soff-Cut Ultra Early Entry system. If it is bent, twisted or damaged, spalling and raveling of a cut may result. Store skid plates carefully and install them properly. Install a new skid plate with each new blade. Never re-use skid plates.

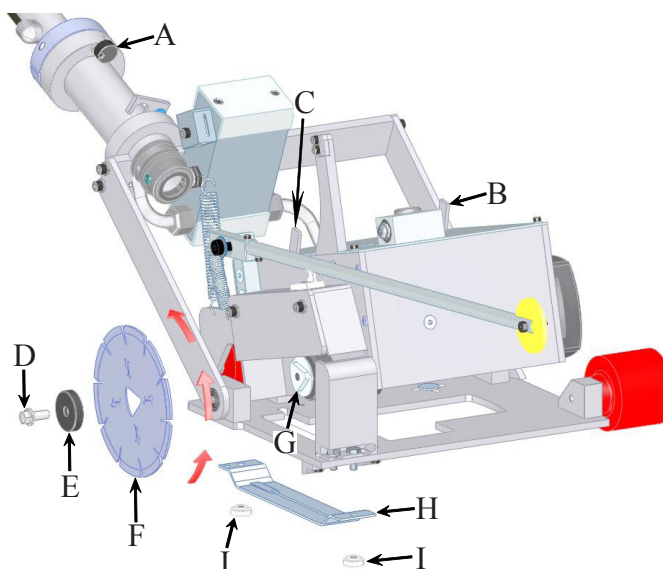

# WHAT IS WHAT

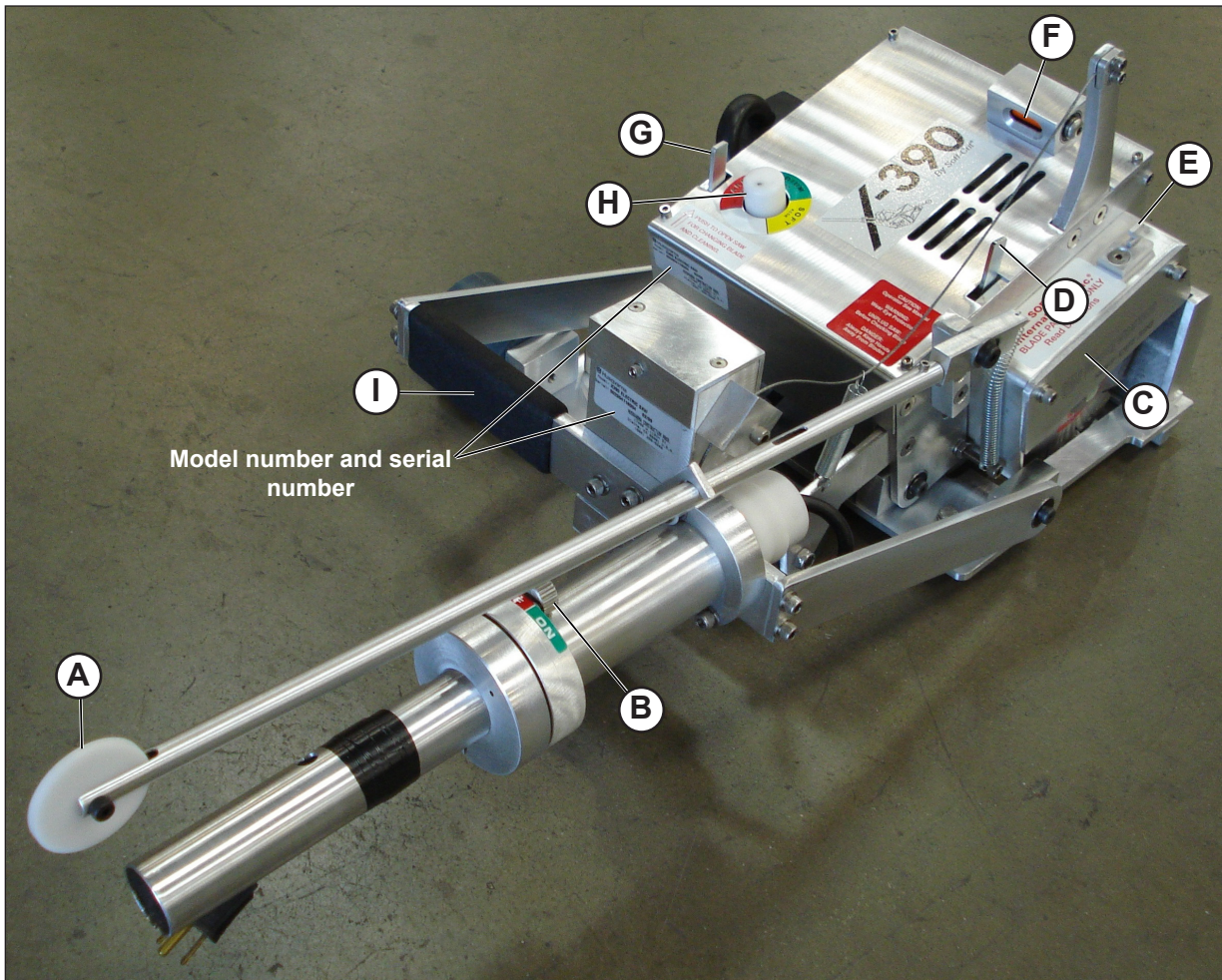

Model number and serial number

## What is what?

- A. Guide
- B. On-Off switch
- C. Blade guard
- D. Arbor lock lever
- E. Hooked guide latch
- F. Depth gauge
- G. Box release lever
- H. Aggregate adjuster
- I. Lifting handle
- J. Hour meter

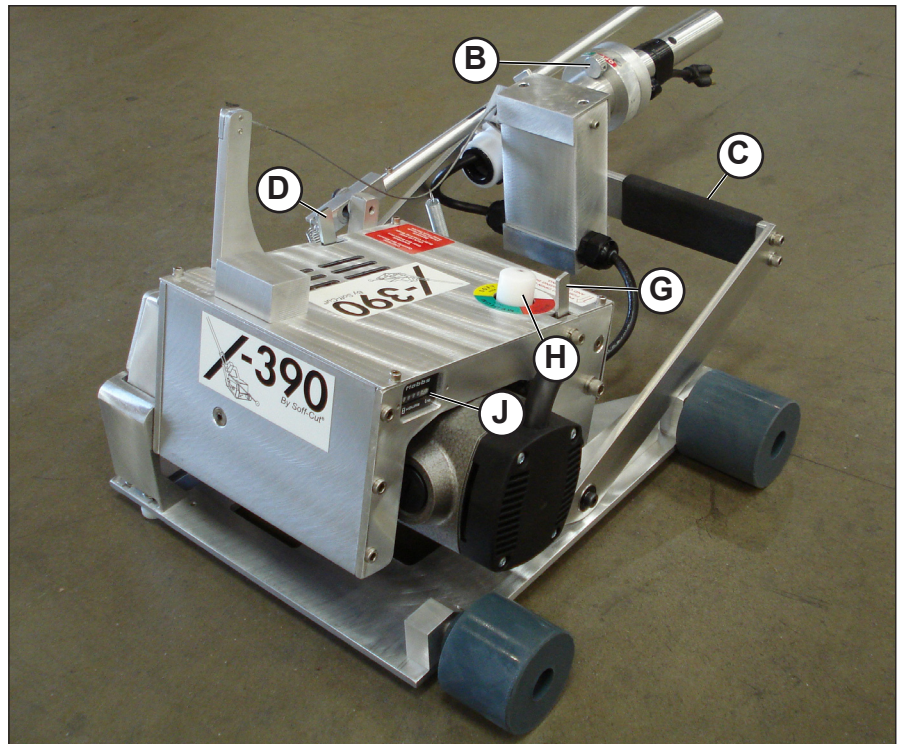

# OPERATING INSTRUCTIONS

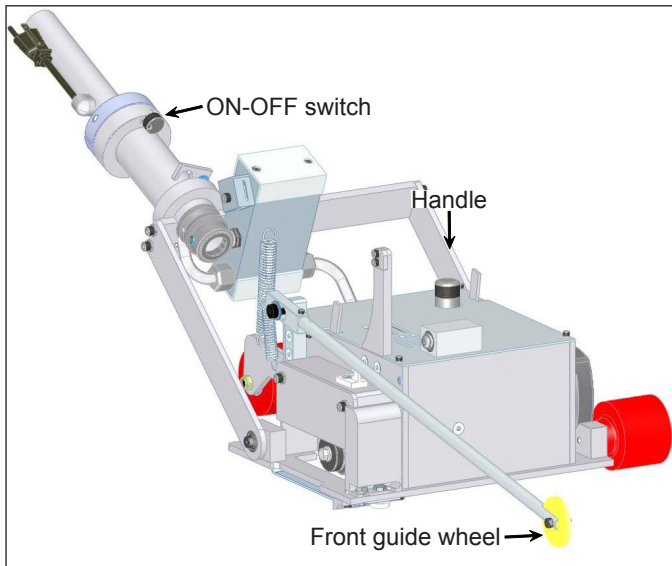

Experience is very important when running the **390** electric saw. A skilled worker is highly recommended. Read all instructions before using the saw. Always do an inspection of the saw before using it. Check that all controls are in good working order. Check for loose bolts or nuts. Check the cord for damage. Insure all guards are secure, undamaged, and properly installed.



## WARNING

**Do not operate the saw unless all guards, safety equipment and the motor ON/OFF switch are in place and operational!**

Repair or replace any damaged components. Check for proper specification of blade and that the skidplate is installed properly. Check that the blade and skid plate are in good condition. Make sure the work site is clean and, well lit and hazard free.

Install the handles depending on the length needed. For best results, use both handles or six (6) feet of length. Attach the extension cord to the handle with the cord clamps. This will keep the cord away from the saw. Make sure the safety switch (B) in the handle is in the "OFF" (red) position. Extend the front guide mechanism (with the front wheel) and latch into place by sliding it forward on the hooked latch (E) on top of the blade guard.

Plug in the extension cord to the proper electrical source. Check that the cord is not tangled or caught on anything. Use a minimum generator size of 2800 watts with a 20 amp circuit breaker for 110 volts.

To begin sawing, line up the saw with the cut line using the white wheel on the front guide (A) and the small notch on the back of the base plate. Turn the safety switch (B) to the "ON" (green) position. To turn the motor on, rotate the handle clockwise while keeping the saw aligned with the cut. Rotating the handle fully to the right will turn the motor on. Hold tightly as the saw will move back toward you slightly when starting to cut.

Hold pressure to the right to keep the motor running. Push the saw forward with even pressure to cut keeping the front guide wheel on the cut line. Push the saw at about half speed for the first 20 feet to allow the blade to develop good diamond exposure or open up and promote full blade life.

Increase the forward speed of the saw until the depth gauge (F) starts to show red. All red is too fast. **Do not force the saw or stall the motor.** At the left side of the rear corner of the saw is the aggregate adjuster knob (H). This adjustment knob will change the down pressure on the cutting blade in relationship to the hardness of the aggregate in your area.

Simply turn the knob accordingly to the soft, medium or hard setting. By using the proper aggregate setting in conjunction with the the depth gauge, you will obtain optimum cutting speeds. If in doubt, contact your ready mix supplier to help determine the aggregate hardness. **Do not add additional weights to the saw.**

When approaching a wall or obstruction, touch the guide wheel and against the wall and then back up to release the guide. The guide will rise out of the way to finish the cut. When the cut is complete, turn the handle quickly counter-clockwise until it stops. The motor will stop, the blade will raise and pressure will be applied to the rear back up wheel.

Push down on the handle until about knee high and roll the saw off the concrete on the two rear wheel. Flip the safety switch to the "OFF" (red) position to avoid false starting.

Periodically, clean any excess concrete from inside the blade guard. The saw will leave two trails of concrete cuttings. Lightly sweep the cutting parallel to the cut with the soft bristle broom. **Do not walk on the joints or transport equipment across the joints until the concrete fully hardens.**



## WARNING

**Do not leave the saw unattended while the engine is running! Always secure the saw from movement while unattended.**



## WARNING

**Before each use, carefully inspect the 390 for any damage to any of its parts and components. Under no circumstance should the 390 or any of its attachments be operated if you find damage or are suspicious that something appears to be damaged.**



## GROUNDING INSTRUCTIONS

Grounding of the **390** electric saw is necessary while in use to protect the operator from electric shock or electrocution. The saw is equipped with an approved three-conductor cord and a three-prong grounding type plug to fit proper grounding type receptacle. Do not remove the grounding prong from the three-prong plug. The green or green and yellow conductor in the cord is the grounding wire. The green wire in the cord must be the only wire connected to the saw's grounding system and must never be attached to an electrically "live" terminal. The saw must be plugged into an appropriate outlet that is properly installed and grounded in accordance with all codes and ordinances.



### WARNING

**Do not remove or modify the plug installed on the saw. Check with a qualified electrician if you are in doubt if the outlet is properly grounded. Do not use the saw if the cord or plug is damaged.**

## EXTENSION CORDS

The **390** electric saw requires three wire extension cords only. The cord should have the required three wire receptacle to accept the saw plug and have a three-prong grounding type plug. As the distance from the supply outlet increases, a heavier gauge extension cord must be used. Using extension cords with too small a gauge of wire causes a serious drop in voltage resulting in loss of power and possible saw damage. Refer to the table shown to determine the required wire gauge. The smaller the gauge number of the wire, the greater the capacity of the cord. For example, a 14 gauge cord can carry a higher amp load than a 16 gauge cord.

### RECOMMENDED MINIMUM WIRE GAUGE FOR EXTENSION CORDS

Volts	Amps	Cord Length in Feet (Meter)			
		25(7.62)	50(15.2)	100(30.5)	150(45.7)
120V	13A	25(7.62)	50(15.2)	100(30.5)	150(45.7)
Minimum Gauge		16AWG	12AWG	10AWG	8AWG

## GENERATORS

The minimum generator required to power the **390** electric saw is 2800 watts continuous with a 120 volt and 20 amp outlet producing 60 hertz single phase power. Generators vary widely so contact your generator distributor or manufacturer for their recommendation.

## MAINTENANCE

### Guards

Check all guards for damage and proper function daily especially the blade guard. The blade guard should be secure to the saw and not damaged.

### Diamond blade

Inspect diamond blades daily for damage, cracks, secure fit to the arbor, loss of segments, warping or overheating. **If any blade shows any of these problems, discard the blade and never use.**

### Skid plate

Inspect the skid plate daily for damage, excessive wear in the blade slot, burrs on the concrete surface side, twisting, and any movement when installed on the saw. Replace the skid plate with each new diamond blade. Never re-use skid plates or spalling and ravelling may result. Periodically, check the skid plate for alignment with the blade. Insure that the blade does not contact the skid plate and adjust if necessary.

### Saw controls

Inspect all controls for proper function daily. **Check the ON/OFF switch for proper operation.**

### Cleaning

Clean the blade guard and bottom plate of any excess concrete build up after each use. Keep the handle clean and dry. Keep all openings and slot on the saw clean and open so air flows freely through the motor compartment to insure proper cooling. Use compressed air and blow out the back side of the motor where the air intake slots are located. Rotate the arbor shaft by hand while cleaning the motor.

### Saw pivot

The saw box should be free to pivot without binding on concrete deposits. Clean and/or replace bearings as necessary.

### Wheels

Wheels should be wiped clean of sealers and concrete deposits. Inspect wheels for damage. Insure wheels roll freely.

### Plastic case

Keep plastic case clean as loose material can lodge in motor during transportation.

### MAINTENANCE SCHEDULE

Check guarding, diamond blade, skid plate, and controls. **Daily**

Clean blade housing assembly and saw. **Daily**

Clean dust and debris from ventilation openings. **Daily**



### CAUTION

**Certain cleaning agents and solvents damage parts. Some of these are gasoline, carbon tetracholide, chlorinated cleaning solvents, ammonia and household detergents that contain ammonia. Avoiding use of these and similar types of cleaning agents minizes the probability of damage.**



### WARNING

**Do not modify the saw! Use only Husqvarna Construction Products replacement parts. Use of unauthorized parts may create a danger or damage the engine.**

# MAXIMIZING THE SOFF-CUT SYSTEM

“ **The timing of concrete operations - especially finishing and jointing - is critical**”, states a quote from the foreword of the American Concrete Institute (ACI) 302.1 R-96. It goes on to say that “Failure to address this issue can contribute to undesirable characteristics in the wearing surface as cracking...” (It mentions other problems).

The patented Soff-Cut Ultra Early Entry system has revolutionized the method used to control random cracking. While Soff-Cut is being specified more today than ever, sometimes the ultra early-entry spec is not always followed on the job site. In order for the Soff-Cut system and an experienced Husqvarna contractor to do a satisfactory job, four components must exist to meet the “specification”:

1. A Soff-Cut Ultra Early Entry dry up-cut saw
2. A Husqvarna Excel Series dry-cutting diamond blade
3. A Husqvarna anti-ravel skid plate installed with every new diamond blade
4. An operator skilled in using the Soff-Cut Ultra Early Entry cutting system.

Without this, joints can not be cut clearly enough to control random cracking before it starts, which is what the building owner is paying for.

The ACI Spec 302.1R-96 says it best:

“Early-entry dry-cut saws use diamond-impregnated blades and a skid plate that helps prevent spalling. Timely changing of skid plates is necessary to effectively control spalling. It is best to change skid plates in accordance with manufacturer’s recommendations...The goal of saw-cutting is to create a weakened plane as soon as the joint can be cut...The timing of the early-entry process allows joints to be in place prior to development of significant tensile stress in the concrete...”

The Portland Cement Association (PCA) engineering bulletin, Concrete Floors on the ground, also states:

“Proper jointing can eliminate unsightly random cracks. Aspects of joining that lead to a good job are choosing the correct type of joint for each location, establishing a good joint pattern and layout, and installing the joint at the correct time... **Timing of joint sawing is critical**...Lightweight, high-speed, early-cut saws have been developed to permit the joint sawing very soon after floor finishing, sometimes within 0 to 2 hours...if the cut is sawn within a few hours after the final finishing, random cracking can be controlled...”

Husqvarna has the only Ultra Early Entry dry-cutting system (Soff-Cut) which controls random cracking through the early timing of the cut. With the patented Soff-Cut method, control joints are usually cut within 0 to 2 hours after the finishing process. Joint cutting should begin as soon as the concrete will support the weight of the saw and the operator at each joint location and before final set. If the joints are not being cut within this time frame then the Soff-Cut Ultra Early Entry method is not being followed and building owners are not getting what they are paying for or the finished product that they expect.

We hope this information is beneficial to building owners, general contractors, concrete finishers, saw operators and the entire industry. For additional information, contact Husqvarna Construction Products at (951) 272-2330 or (800) 776-3328, or see our website [www.husqvarnacp.com](http://www.husqvarnacp.com).

# SAWING CONTRACTION JOINTS

As concrete hydrates or cures and begins to set, it develops internal stresses which may cause random cracks. Random cracks cast doubt on the quality and workmanship of the concrete. Contraction joints are cut in concrete to relieve these stresses before they seek their own relief in the form of random crack. The Soff-Cut Ultra Early Entry system controls random cracking through the early timing of a saw cut at predetermined locations to create weakened planes in the concrete that subsequently crack at the bottom of the cut to relieve stress. Husqvarna sawed contraction joints should be a minimum of 1/8th the concrete depth and a minimum of 1" (25mm) deep. Contraction joints should be sawn as soon as the concrete will support the weight of the saw and the operator without marking or damaging the concrete. There are many possibilities for joint layout. Joint layout should be provided, the saw contractor should submit a detailed joint layout for approval prior to cutting. Several factors affect joint spacing including:

- Concrete thickness
- Type, amount and location of reinforcement
- Shrinkage potential of concrete-cement (type, quantity), aggregate (size, quantity, quality), water to cement ratio, admixtures, concrete temperature
- Base friction
- Slab restraints
- Layout of foundations, racks, pits, equipment pad, trenches, etc.
- Environmental factors - temperature, wind, humidity
- Methods and quality of concrete curing.

Generally, contraction joint patterns should divide slabs into approximate square panels per the recommended spacing shown.

<b>RECOMMENDED CONTRACTION JOINT SPACING</b>	
<b><u>Concrete thickness, in. (mm)</u></b>	<b><u>Maximum spacing, ft. (m)</u></b>
3.5 (90)	8 (2.4)
4, 4.5 (100, 114)	10 (3.0)
5, 5.5 (125, 140)	12 (3.6)
6 (150) or greater	15 (4.5)

At all intersecting cross cuts, install Husqvarna joint protectors at each joint to prevent joint damage. Install an additional joint protector where the right wheel will cross the joint to prevent concrete damage.

---

# TROUBLESHOOTING

---

## SAW IS SPALLING AND RAVELLING CUT

- Check to see if the diamond blade is worn out, glazed, warped or damaged.
- Insure that the diamond blade moves freely through the skid plate without contact.
- Check skid plate for excessive wear or gap around the diamond blade.
- Check bottom of skid plate for metal burrs or irregularities.
- Insure skid plate is not twisted or bent.
- Do not twist or move the saw sideways while cutting.
- Check that the electric motor is running smoothly and properly.
- Insure the diamond blade is properly mounted and secured with clean flanges.
- Insure that the diamond blade is the correct specification for your area.
- Insure the slab is clean with no debris that could raise the skid plate or saw while cutting.
- Use Husqvarna joint protectors at all cut intersections.
- Clean excess concrete debris from the blade guard assembly, front diverter, skid plate and bottom plate.
- Do not stop the electric motor while the blade is in the cut.

---

## SAW PULLS TO ONE SIDE WHILE SAWING

- Check the front guide is properly aligned with the center of the diamond blade.
- Check to see if diamond blade is worn out, glazed, warped or damaged.
- Do not twist or move the saw sideways while cutting. Make gradual changes in pressure on the handle bar to control the saw in the cut.
- Insure that all wheels roll freely and smoothly.
- Do not force the saw. Allow the diamond blade to cut at its own rate of speed.
- Check the skid plate for damage or burrs.

## ELECTRIC MOTOR WILL NOT START

- Check that the power cord is properly plugged in correctly and you have the proper voltage.
- Check that the circuit breaker on the electrical outlet is not tripped.
- Check that the safety switch on the handle is in the "ON" (green) position.
- Insure that you have rotated the handle clockwise to the farthest position.
- Check that the blade shaft rotates freely and no concrete build up in the blade block or motor.
- Check that the generator is ON and at full throttle.
- Check that the ground fault interrupter on the electrical outlet is not tripped.
- Check that the extension cord is not faulty.

---

## MOTOR RUNS BUT BOGGS DOWN WHEN CUTTING

- Check that the extension cord is the proper wire gauge size for the length of the used.
- Check that the generator is atleast 2800 watts and is at full throttle.
- Check that the diamond blade is the correct specification for the aggregate being cut.
- Check that the diamond blade is not worn out, glazed, warped or damaged.
- Insure that the diamond is not being twisted in the cut.
- Check that the skid diamond blade is not contacting the skid plate when cutting.
- Check the aggregate adjustment knob is set for the proper aggregate for your area.
- Insure that the diamond blade is the correct specification for your area.
- Insure the diamond blade is properly mounted and secured with clean flanges.

---

## TECHNICAL SPECIFICATIONS

---

### Weight and Dimensions 390

Weight	27 lbs	12 kg
Operating weight	30 lbs	14 kg
Length (Handle not installed)	30 inch	762 mm
Width	15 inch	381 mm
Height	11 inch	279 mm

### Blade

Material cut	Green concrete only
Blade type	5.5 inch (140 mm) dry cut diamond blade with tri-arbor
Blade rotation	Counter clockwise, upcutting
Blade shaft speed	6850 rpm
Cutting depth	7/8 to 1 1/18 inch (22 to 28.5 mm) depending on amount of blade wear
Cutting distance from wall	2.0 inch (51 mm)

### Average cutting rate - Estimate only. Speed will vary with job conditions and concrete mixes.

Soft aggregates	10 ft/min	3.0 m/min
Medium aggregates	6.0 ft/min	1.8 m/min
Hard aggregates	3.0 ft/min	0.9 m/min

Blades are available in 5.0 inch (127 mm) and 5.5 inch (140 mm) diameters and in 0.095 inch (2.4 mm), and 0.225 inch (5.7 mm) widths

### Motor Specification:

15 Amp, 60 hertz single phase, 120V Air cooled, universal electric motor with gear reduction

---

## CONFORMITY CERTIFICATES

---

**CALIFORNIA AIR RESOURCES BOARD (CARB):** CARB standards do not apply to this machine.

For more information see the website <http://www.arb.ca.gov>

---

# WARRANTY

---

## HUSQVARNA EQUIPMENT WARRANTY

New **390** saw sold by Husqvarna Construction Products are warranted to be free from manufacturing defects in normal service for a period of six (6) months for labor and up to one (1) year on parts from date of purchase by the original consumer purchaser or date of introduction into rental company fleet.

Our obligation under this warranty is expressly limited to the replacement or repair at Husqvarna Construction Products, or at a service facility designated by us, of such part or parts if inspection shall disclose it to have been defective.

This warranty does not apply to defects caused by damage, unreasonable use, faulty repairs made by others (or defects caused by failure to provide reasonable maintenance, while in the possession of the consumer). Further, the warranty is void if the product, or any of its components, are altered or modified by the consumer purchaser, or if the product is used in an inappropriate manner not recommended by the manufacturer.

The use of any other blade except Husqvarna Construction Products blades and skid plates will void the warranty and could cause internal damage to the motor.

In no event shall Husqvarna Construction Products be liable for any indirect, incidental or consequential damages from the sale or use of the product. This disclaimer applies both during and after the term of this warranty.

This warranty gives you specific legal rights and other possible rights, which may vary from state to state. Some states do not allow the exclusion or limitation of incidental or consequential damages so the above limitation or exclusion may not apply to you. Some states do not allow limitations on how long an implied warranty lasts so the above limitation may not apply to you.

## WARRANTY ON ENGINE

Husqvarna Construction Products does not perform warranty repairs or reimburse for warranty repairs on engines. Engine warranties are provided by the engine manufacturer.

To obtain warranty repair: Take your engine along with your proof of purchase to any general purpose dealer or distributor nearest you.

If you are unable to obtain warranty service or are dissatisfied with the warranty service you received, contact the owner of the dealership involved. Normally, this should resolve your problem. For further assistance, call our parts and service department at 1-800-776-3328 or 1-951-272-2330.

## WARRANTY ON REPLACEMENT PARTS

There is a three (3) months warranty from date of purchase on all replacement parts.

## COPYRIGHT 2009 HUSQVARNA CONSTRUCTION PRODUCTS

Covered by one or more of the following U.S. Patents

4769201, 4889675, 4928662, 4938201, 5056499, 5086750, 5184597, 5303688, 5305729, 5373834, 5441033, 5505189, 5507273, 5570677, 5575271, 5579754, 5582899, 5603310, 5660161, 5664553, 5666939, 5689072, 58030371, 6892719, 6990972, 7073495, 7163010, 7258115.

Other U.S. and foreign patents pending.



[www.husqvarnacp.com](http://www.husqvarnacp.com)

505 41 78-11

2014-09-24

Printed In U.S.A.