

Certified Pre-Owned high-powered vacuum for the Professional Contractor



**High Productivity & High Value...VORTEC690**

Intec's VORTEC family of vacuums offer high productivity with robust engineering combined to provide the highest value vacuum in today's market. Designed for fast & profitable recycling of spray applied insulation, removal of damaged insulation due to fire, water, and smoke, and HVAC cleaning.

Engineered for High Productivity



industry standard  
impeller

**VORTEC 690**  
impeller

Built-to-Last for High Value Generation

- IMPELLER
- ✓ oversized for higher production
- ✓ precision balanced
- ✓ serrated to pulverize unwanted materials
- WHEELS Run-Flat
- SHROUD
- ✓ thick gauge
- HANDLE
- ✓ Reversible & removable



Patents Pending

Honda's GX690 V-Twin delivers over 22 net horsepower outperforming most all motors used in vacuums today. Variable Timing Digital Ignition, exclusive to Honda, provides optimal timing based on engine speed – delivering consistent power under load, excellent starting, and smooth operation, in addition to reduced fuel consumption with outstanding emissions performance.

Reliable

Dependable

Value

Intec

800-666-1611

www.inteccorp.com

Rev: 20150607

**Intec's Professional Grade Equipment**

Engineered for High Productivity

Built-to-Last for High Value Generation



Let Your Profits SOAR

...with Intec



**VORTEC™**  
 POWERED by HONDA  
 by Intec



## Specifications

Color may be silver; dimensions directionally accurate

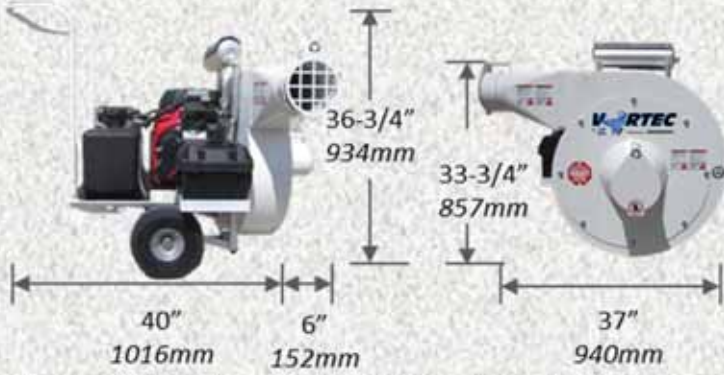

- Body: Painted steel with 10" run-flat wheels.
- Weight: 362 lbs (165kg).
- Inlet: 6" standard. Depending on configuration, user may be able to change to 8".
- Outlet: 6".
- Motor: Electric start Honda GX690 V-Twin 22+ net hp.
- Oil Alert system shuts motor when oil is low to prevent engine damage.
- Fuel: 5 gallon gas tank.
- Oversized Fan wheel.
- Thick gauge steel
- Warranty: engine over 1 year remaining; 90 days other.

## Features

Honda GX690 electric start

V-Twin Engine

- Extra quiet exhaust
- Oversized shaft
- Hour meter



Pivoting inlet & outlet gates promote safe operation, further enhanced by the vacSHIELD



Oversized impeller with serrated angles pulverizes unwanted foreign materials

Reversible & Removable Handles

## Accessories

### VORTEC vacSHIELD

Enhance Safety & Extend the Vacuum's Life.

- ✓ Safety enhanced by limiting foreign objects from exiting vacuum at high speeds.
- ✓ Vacuum's Life extended by preventing foreign materials from entering the vacuum and potentially causing catastrophic damage to the impeller, shroud, and engine.

Can be used with all vacuums



- Mounts directly to VORTEC690
- VORTEC390 uses in front of vacuum

gix \ Çaxv C Akwzx

Provide the finest equipment in the industry with the highest standards while continuing to strive for 100% satisfaction.

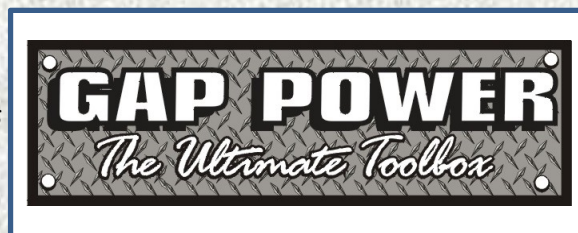

Manufactured By

