



Click Here To View
Item at

www.GapPower.com

*Sales • Rentals
Parts & Service*



Illustrated Parts & Packing List

815 Rice Lake Street, Owatonna, MN 55060

For a complete distributor & dealer list go to www.gandy.net

4908024

18 x 24 Lawn Roller

(All Hardware In Hardware Bag Unless Otherwise Specified)

Carton Containing The Following:

- 1 4908024-3.....Drum (18 x 24 Roller)
- 2 4908024-4.....Mounting Arm, Hitch
- 1 4908024-5.....Hitch-Handle
- 1 4908024-6.....Scraper Angle
- 1 49H8024Parts Bag (see page 10 for contents)
- 1 Parts & Packing List

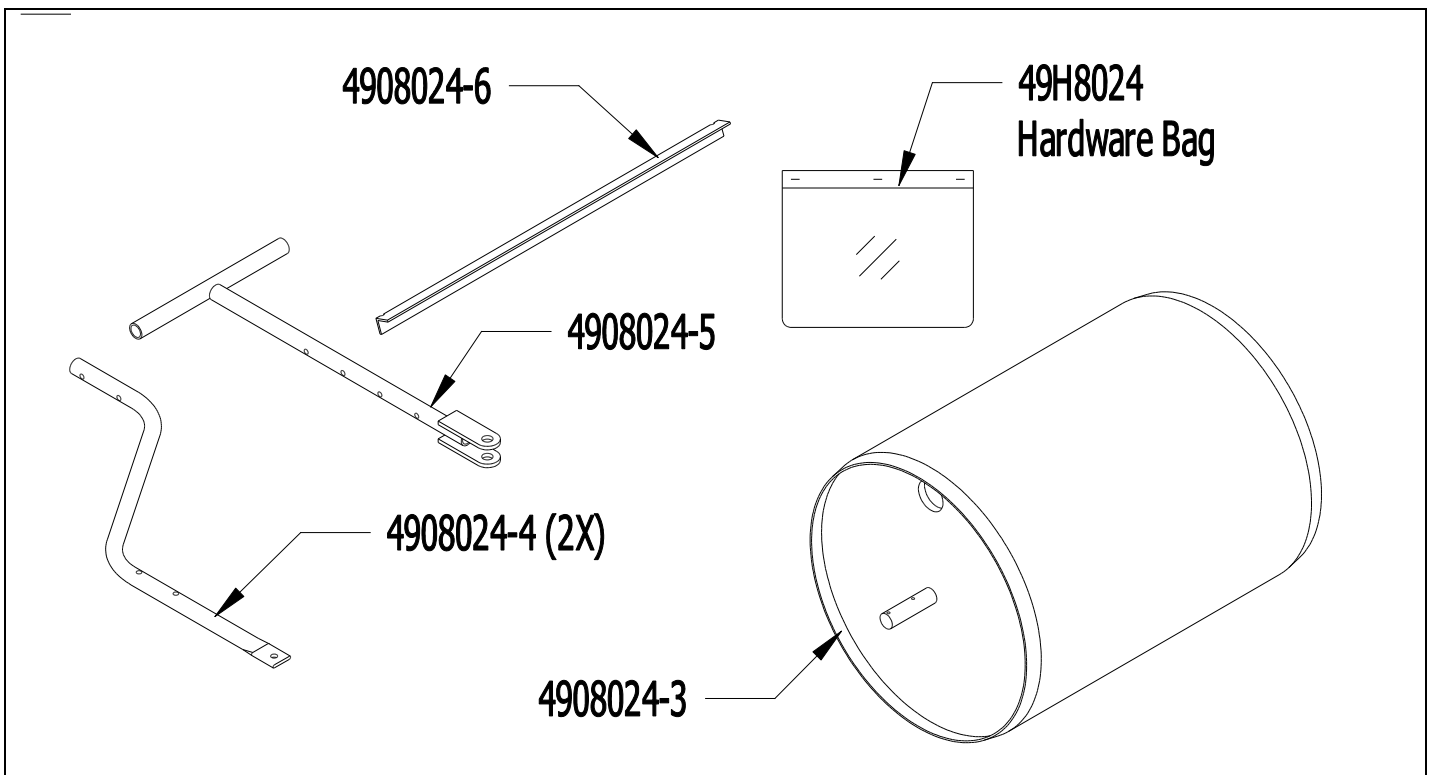

18 x 24 Roller Complete Parts List

(All hardware in hardware bag unless otherwise specified.)

- 1.....4908024-3Drum (18 x 24 Roller)
Use: 2 Decal, Gandy Diamond (N02-0001-093) **(in Place)**
- 2..... 4908048-7.....Mounting Bracket Arm (Bearing) **(in Hardware Bag) (Grease Before Use)**
Use: 2 Grease Fitting (D01-5010-050) **(in Place on Bearing)**
4 SAE Washer (1-inch) (C02-1000-020)
4 Cotter Pin (3/16 x 1-1/2) (C20-0187-040)
- 1..... M05-2000-010.....Rubber Plug 2-inch Snap-Tite (M05-2000-010) **(in Hardware Bag)**
Use: 2 S-Hook #63 (M11-0063-000)
1 Sash Chain #25 (8-Links) (F03-0025-008)
- 2..... 4908024-4.....Mounting Arm, Hitch
Use: 2 Plastic Plug (3/4) (J02-0750-050)
2 Carriage Bolt (3/8 x 1) (C04-0375-040)
2 Whiz Flange Nut (3/8) (C01-0375-030)
- 1..... 4908024-5.....Hitch-Handle
Use: 2 Grip (1 x 4-5/8) (J01-1000-462)
2 Hex Bolt (5/16 x 3-1/2) (C03-0312-141)
4 Wrought Washer (5/16) (C02-0312-030)
2 Wing Nut (5/16) (C01-0312-020)
- 1..... 4908024-6.....Scraper Angle
- 2..... 4908024-8.....Mounting Bracket, Scraper **(in Hardware Bag)**
Use: 2 Spring (E01-05215-3)
2 Hex Bolt (1/4 x 2-1/4) (C03-0250-090)
2 Lock Nut, Nylon (1/4) (C01-0250-040)
2 Carriage Bolt (5/16 x 1-1/2) (C04-0312-060)
2 Whiz Flange Nut (5/16) (C01-0312-030)

Continued on next page.

- 1.....49H8024.....Hardware Bag Containing**
- 2 C01-0250-040.....Lock Nut, Nylon (1/4)
 - 2 C01-0312-020.....Wing Nut (5/16)
 - 2 C01-0312-030.....Whiz Flange Nut (5/16)
 - 2 C01-0375-030.....Whiz Flange Nut (3/8)
 - 4 C02-0312-030.....Wrought Washer (5/16)
 - 4 C02-1000-020.....SAE Washer (1-Inch)
 - 2 C03-0250-090.....Hex Bolt (1/4 x 2-1/4)
 - 2 C03-0312-141.....Hex Bolt (5/16 x 3-1/2)
 - 2 C04-0312-060.....Carriage Bolt (5/16 x 1-1/2)
 - 2 C04-0375-040.....Carriage Bolt (3/8 x 1)
 - 4 C20-0187-040.....Cotter Pin (3/16 x 1-1/2)
 - 2 E01-05215-3Spring
 - 1 F03-0025-008Sash Chain #25 (8-Links Long)
 - 2 J01-1000-462.....Grip (1 x 4-5/8)
 - 2 J02-0750-050.....Plastic Plug (3/4)
 - 1 M05-2000-010.....Rubber Plug 2-inch Snap-Tite
 - 2 M11-0063-000.....S-Hook #63
 - 2 4908024-8.....Mounting Bracket, Scraper
 - 2 4908048-7.....Mounting Bracket, Arm (Bearing) (with D01-5010-050 Grease Fitting In Place)

Hardware Bag Contents:

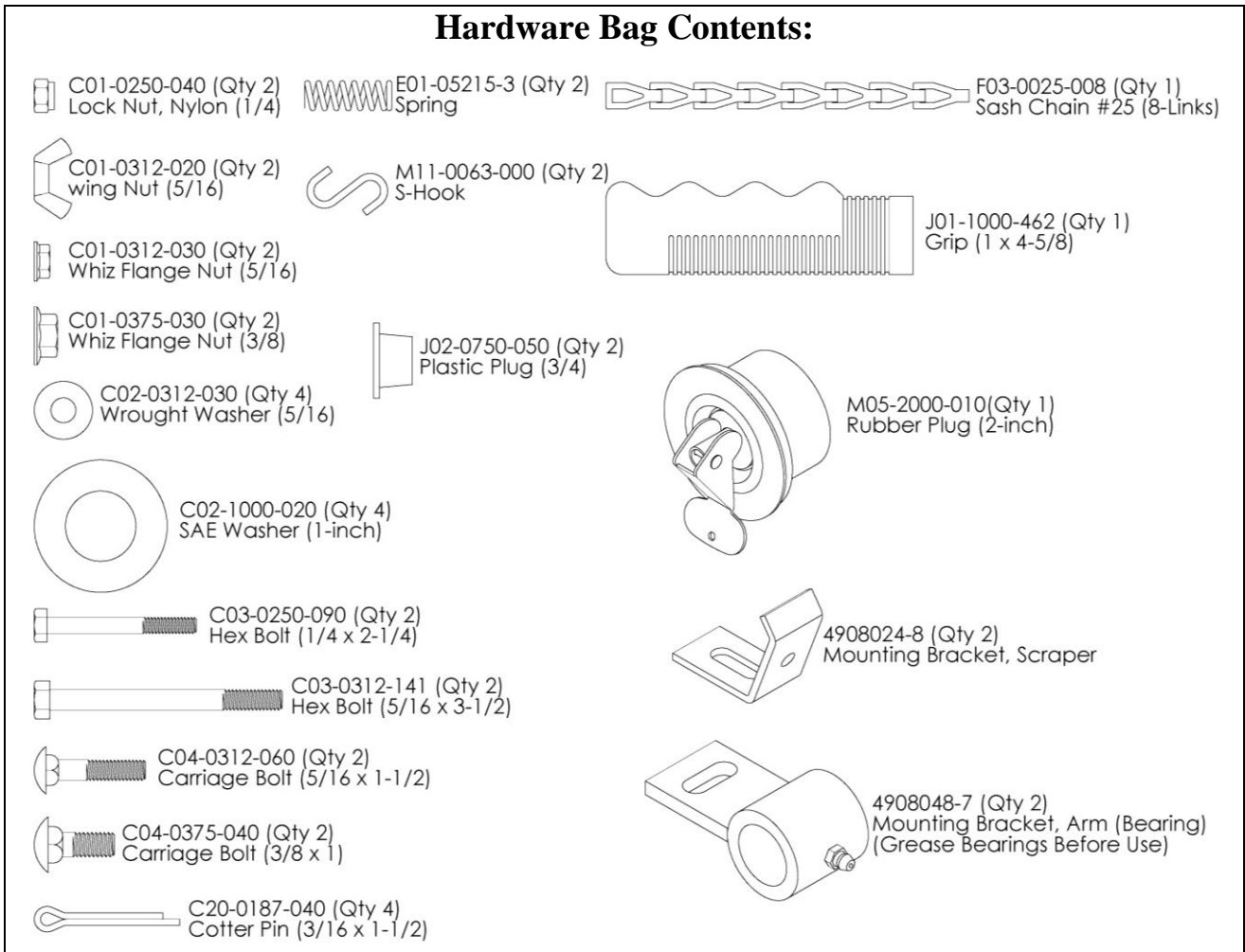

Assembly Instructions (See diagrams on following pages.)

1. Attach bearings (4908048-7) to axle on roller using two 1-inch washers (one each side of bearing) and two 3/16 x 1-1/2 cotter pins. Secure cotter pins. **Note:** On end of roller with hole, align eye of cotter pins so they are closest to the hole. This will be used in step #9.
Grease bearings now before use. Note: Failure to do so will result in damage to axle shaft.
2. Push one grip (J01-1000-462) on each end of the hitch-handle as shown.
3. Insert plastic plug (J02-0750-050) into end of each mounting arms (4908024-4).
4. Attach both mounting arms (4908024-4) to hitch-handle (4908024-5) using the two 5/16 x 3-1/2 hex bolts, 5/16 washers and 5/16 wing nuts as shown. Do not tighten leave loose until step #5.
5. Attach flat end of mounting arms (assembled to hitch-handle) to bearings (assembled in step #1) using the 3/8 x 1 carriage bolts and whiz flange nuts as shown. Do not tighten leave loose. Tighten wing nuts holding hitch/handle to mounting arms. Center mounting arms hitch-handle on roller. Before tightening carriage bolts on bearings and mounting arms, center bearing between 1-inch washers and tighten whiz flange nuts securely.
Repeat of other side.
6. Attach one scraper mounting bracket (4908024-8) to each end of scraper angle (4908024-6) using the 1/4 x 2-1/4 hex bolts, springs (E01-05215-3) and 1/4 nylon lock nuts as shown. Tighten nylon lock nut so the 1/4 bolt protrudes out of the lock nut about 1/8-inch.
7. Attach scraper assembly (step #6) to mounting arms as shown using the two 5/16 x 1-1/2 carriage bolts and 5/16 whiz flange nuts. Do not tighten. Adjust scraper to leave a slight clearance from roller. Check clearance all the way around roller to be sure scraper is not rubbing on roller. Tighten carriage bolts securely.
8. Assemble S-hook to one end of sash chain as shown. Insert other end of S-hook into hole in rubber plug snap flange (M05-2000-010) as shown. Clinch both ends of the S-hook to secure sash chain to rubber plug.
9. Insert other S-hook into inner most cotter pin assembled to roller axle (Step #1) as shown. Insert rubber plug into hole on roller, ensuring that length of sash chain is as desired for easy fit. Connect end of sash chain to S-hook. Adjust S-hook position if necessary and clinch both ends of S-hook to secure rubber plug to axle.
10. If bearings were not greased in Step#1 do so now. **Failure to do so will result in damage to axle shaft.**
11. To convert hitch-handle from pull type handle to tractor hitch. Loosen all wings nut as shown. Remove bolt as shown. Pivot handle 180 degrees so tractor hitch is to the front. Replace bolt and tighten both wing nuts securely. **Note:** If bolt is not easily removed from handle, one or both of the carriage bolts fastening the mounting arms to the bearings will have to be loosened to pivot handle. Remember to securely retighten all hardware.
The hitch-handle can be adjusted to different lengths per the four holes in the center tube if needed.

Operation & Storage (Please read the following for proper use and storage.)

Grease fittings on each bearing before use and every hour during prolonged use. 3 MPH max travel speed.
Check all bolts for tightness after first two hours of use; check periodically thereafter.
Do not cross rocky areas, gravel drive ways or paved areas as large or small rocks will dent or could puncture roller.
Drain water before transport or storage. Leave rubber plug out over storage so any small amounts of water will evaporate. Water will freeze over winter and can damage roller beyond repair.

Optional Accessories: (Ordered separately not part of roller.)

Optional Clamp-On Aerator 490871; ordered separately.

Assembly Diagrams

Step #1

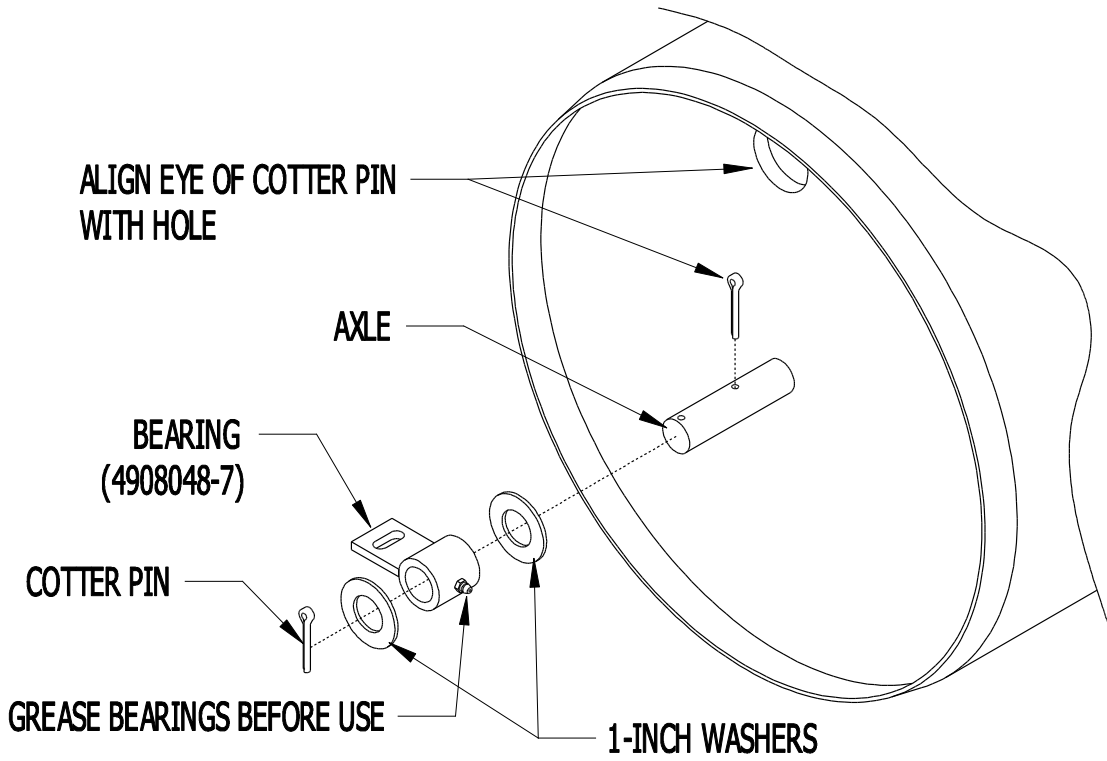

Step #2

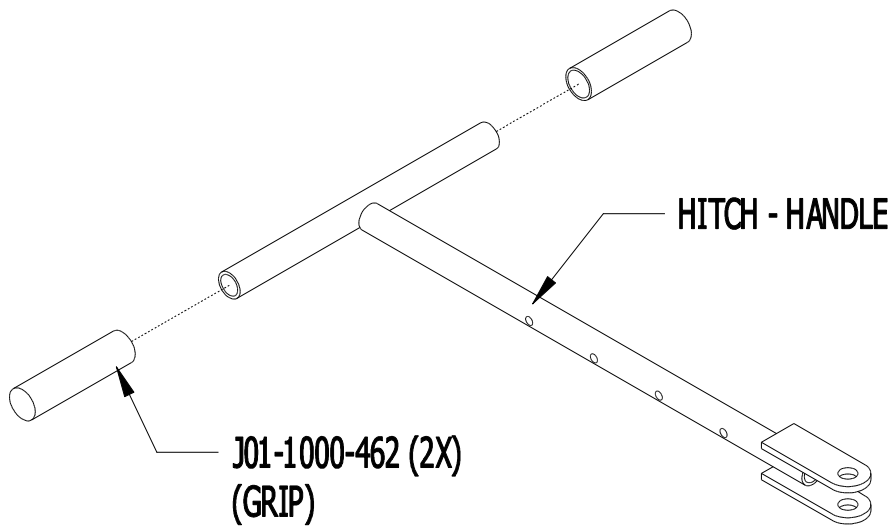

Step #3

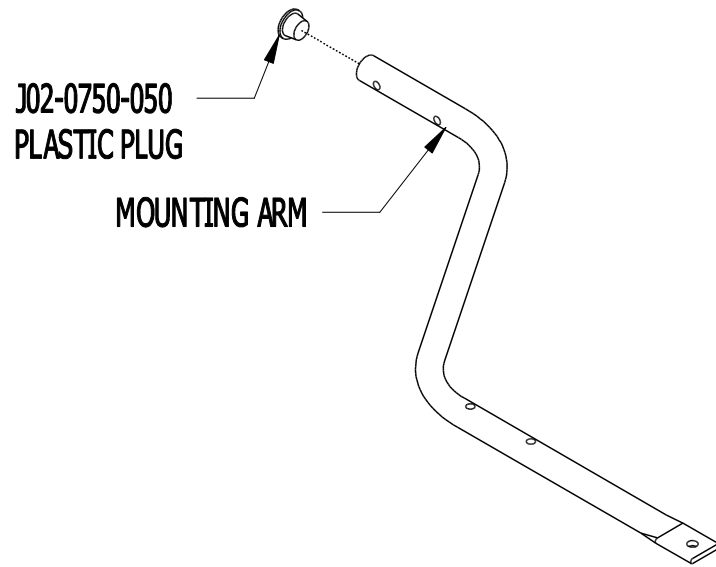

Step #4

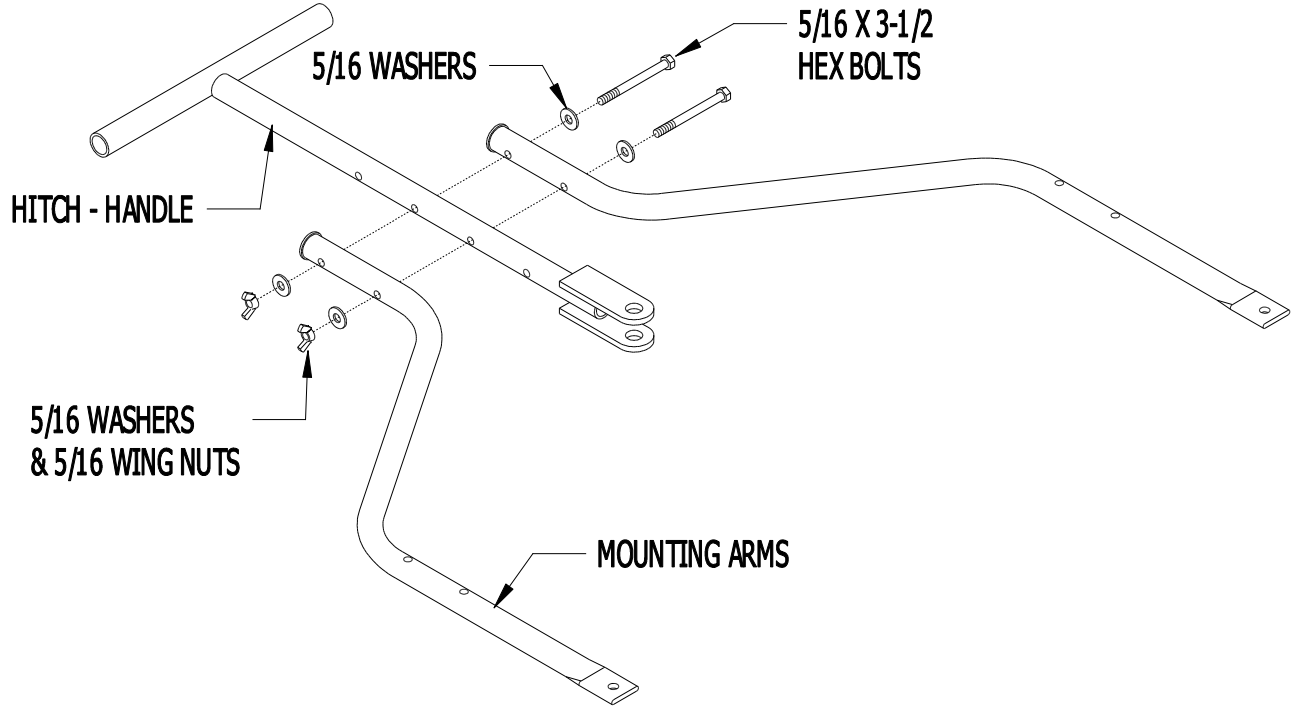

Step #5

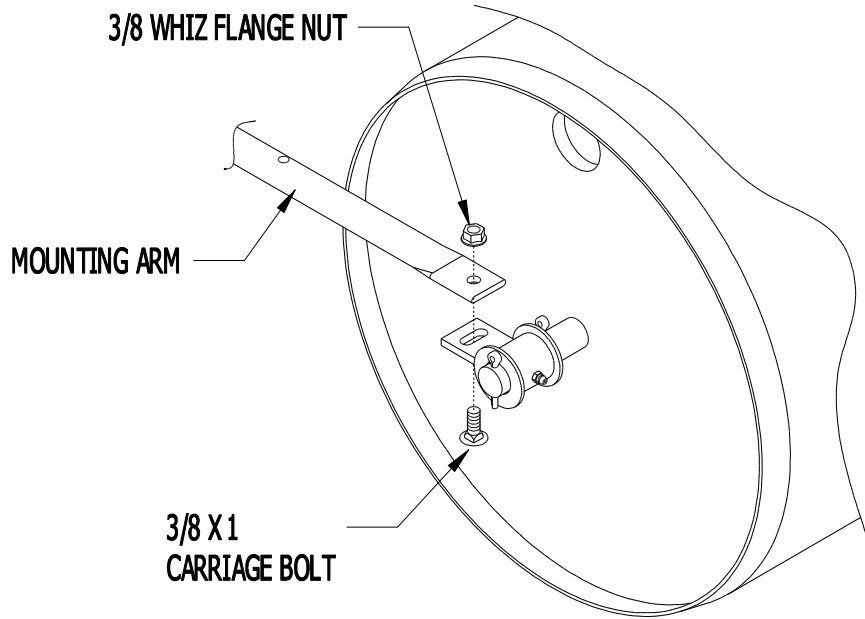

Step #6

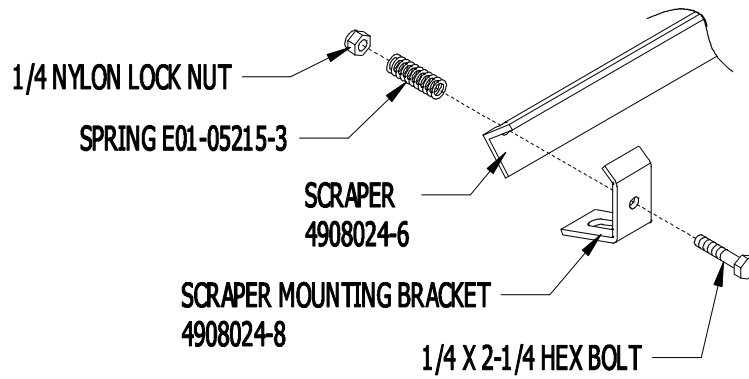

Step #7

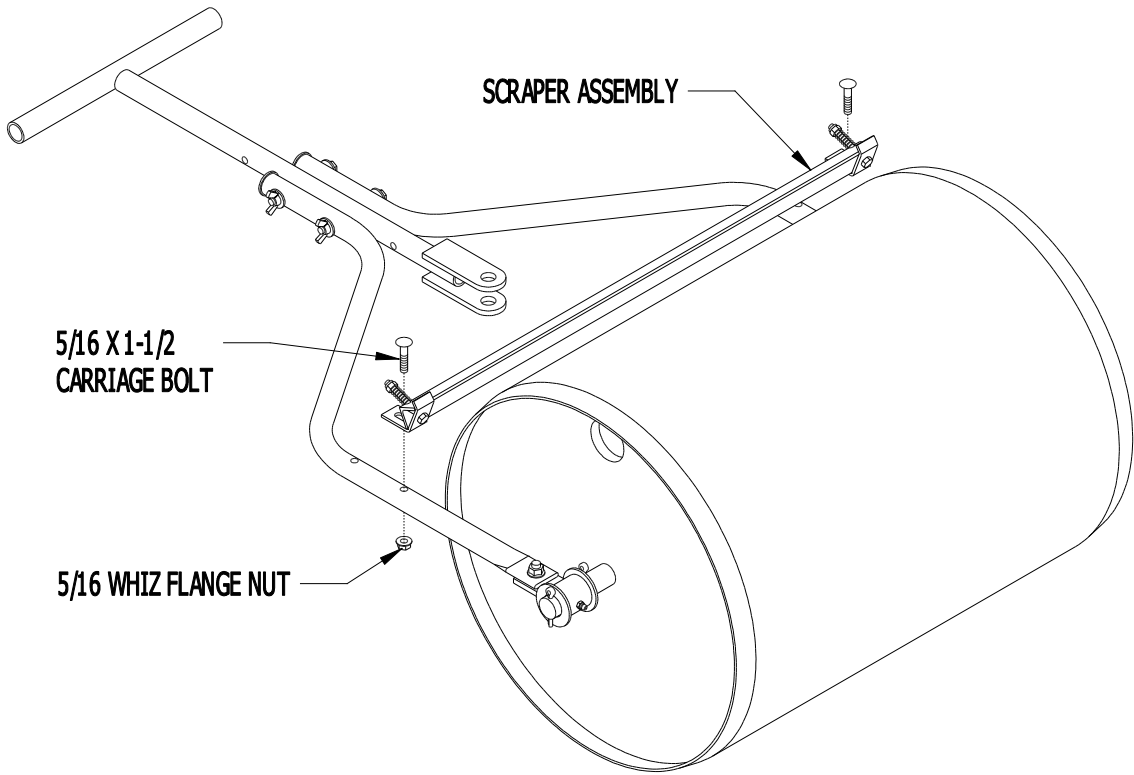

Step #8

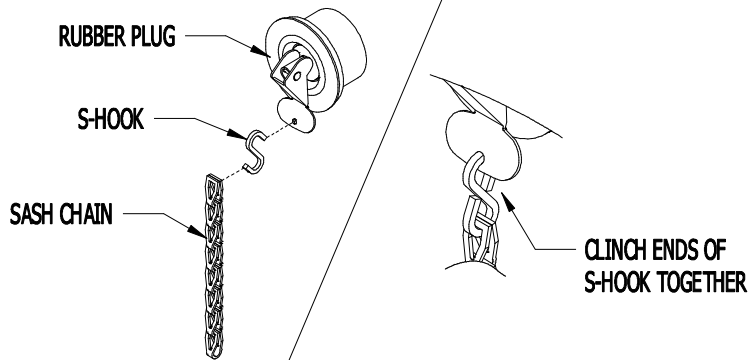

Step #9

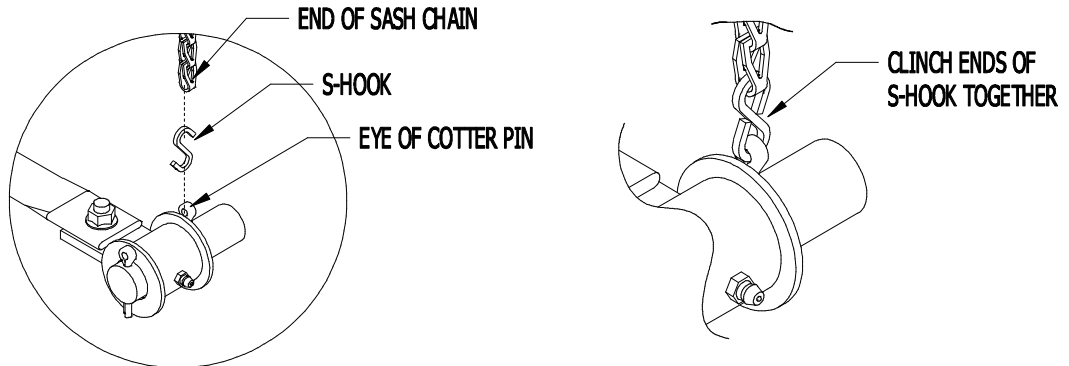

Step #10

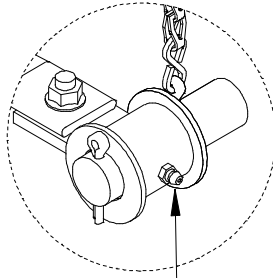

**GREASE BEARINGS BEFORE USE
BOTH SIDES**

**FAILURE TO DO SO WILL RESULT
IN DAMAGE TO AXLE SHAFT**

Step #11 Hitch-Handle Conversion

HANDLE

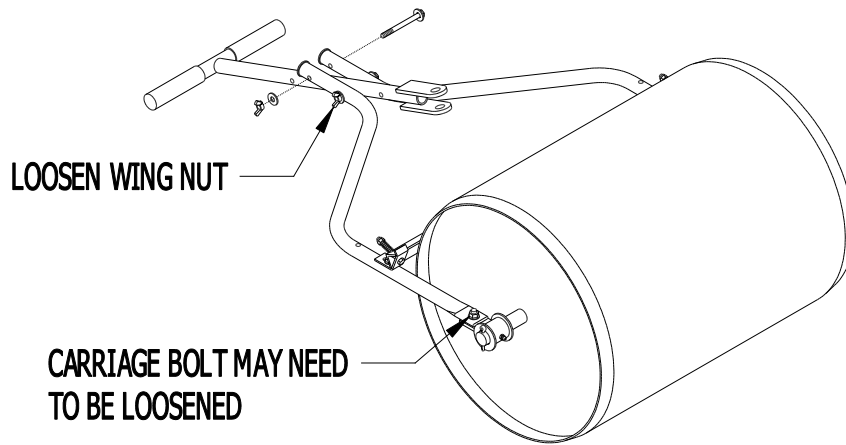

HITCH

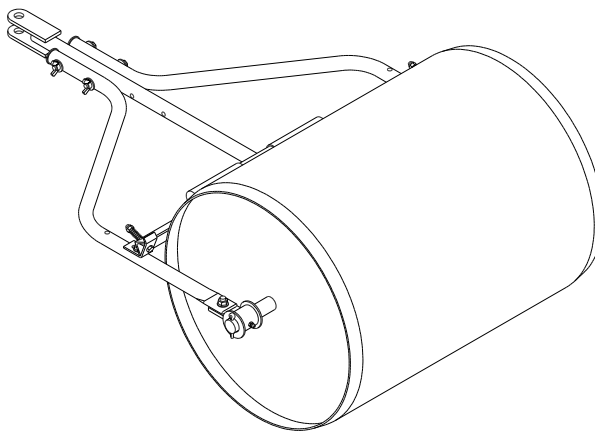

18 x 24 Roller Schematic

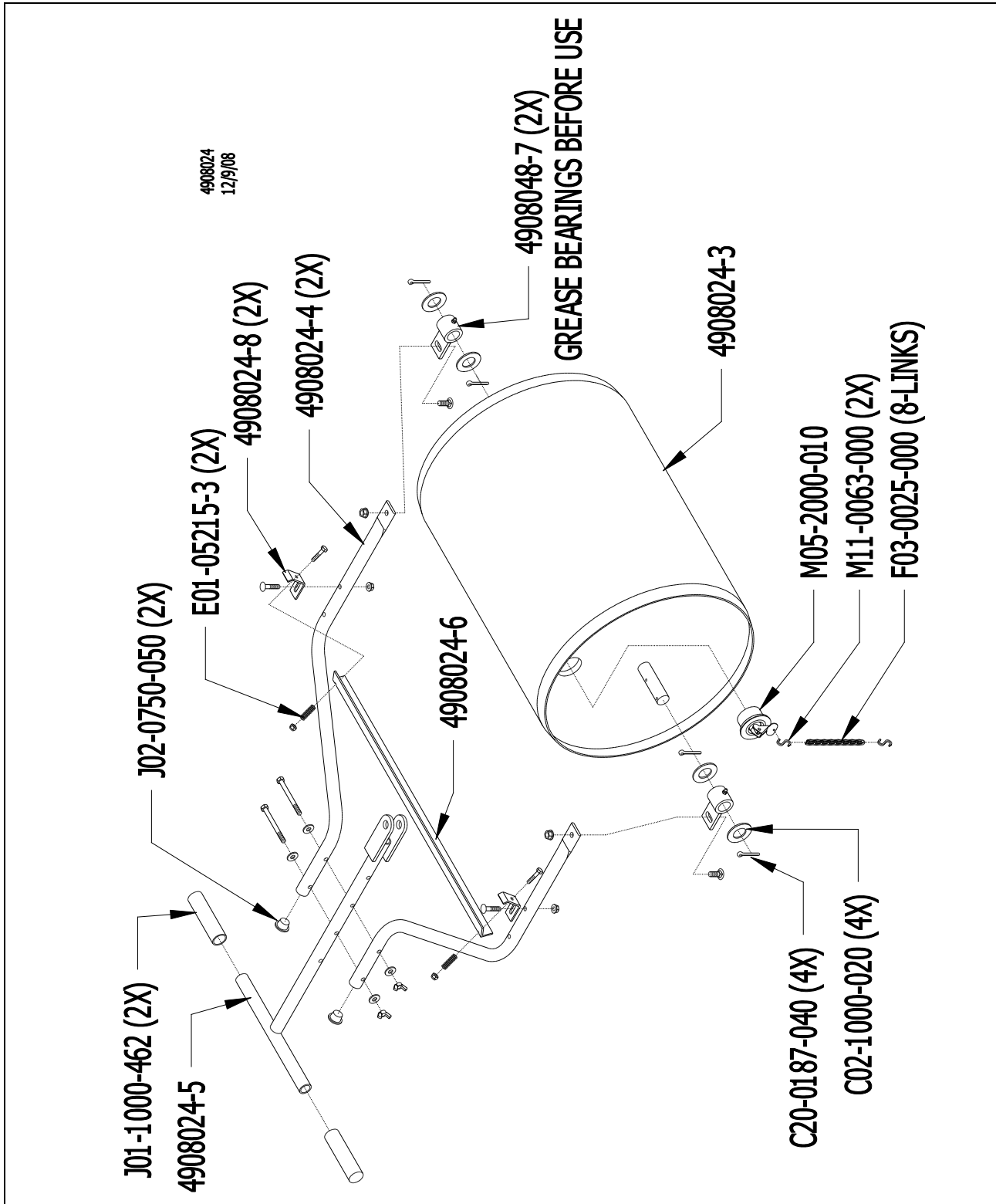

GDY-4908024-PPL
 Drawings 4908024-B, 49H8024, 4908024-A, 4908024
 December 2, 2013
 Revised From (6/29/12)
 Printed in the USA