

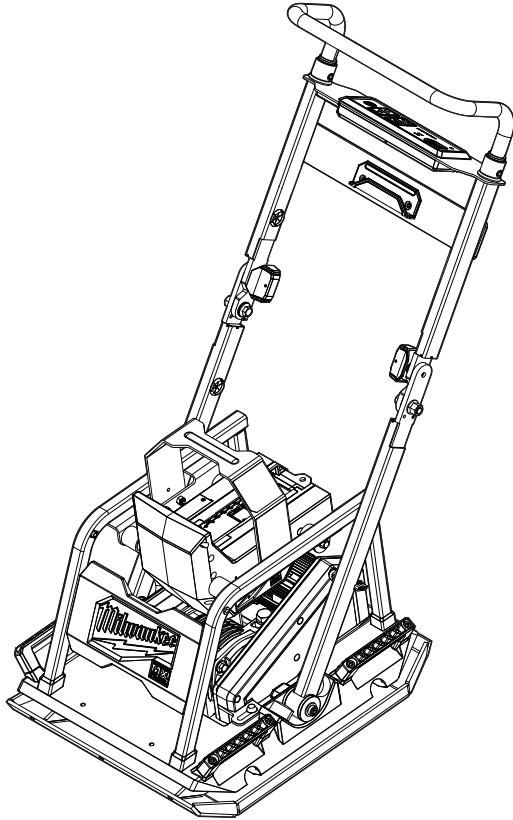

OPERATOR'S MANUAL  
MANUEL de L'UTILISATEUR  
MANUAL del OPERADOR



Cat. No. / No de cat.  
**MXF220**

**MX FUEL™ 20" PLATE COMPACTOR**  
**508 mm (20") COMPACTEUR À PLAQUE MX FUEL™**  
**508 mm (20") COMPACTADOR DE PLACA MX FUEL™**



**WARNING** To reduce the risk of injury, user must read and understand operator's manual.

**AVERTISSEMENT** Afin de réduire le risque de blessures, l'utilisateur doit lire et bien comprendre le manuel.

**ADVERTENCIA** Para reducir el riesgo de lesiones, el usuario debe leer y entender el manual.

## GENERAL POWER TOOL SAFETY WARNINGS

**⚠WARNING** Read all safety warnings, instructions, illustrations and specifications provided with this power tool. Failure to follow all instructions listed below may result in electric shock, fire and/or serious injury. **Save all warnings and instructions for future reference.** The term "power tool" in the warnings refers to your mains-operated (corded) power tool or battery-operated (cordless) power tool.

### WORK AREA SAFETY

- **Keep work area clean and well lit.** Cluttered or dark areas invite accidents.
- **Do not operate power tools in explosive atmospheres, such as in the presence of flammable liquids, gases or dust.** Power tools create sparks which may ignite the dust or fumes.
- **Keep children and bystanders away while operating a power tool.** Distractions can cause you to lose control.

### ELECTRICAL SAFETY

- **Power tool plugs must match the outlet. Never modify the plug in any way. Do not use any adapter plugs with earthed (grounded) power tools.** Unmodified plugs and matching outlets will reduce risk of electric shock.
- **Avoid body contact with earthed or grounded surfaces, such as pipes, radiators, ranges and refrigerators.** There is an increased risk of electric shock if your body is earthed or grounded.
- **Do not expose power tools to rain or wet conditions.** Water entering a power tool will increase the risk of electric shock.
- **Do not abuse the cord. Never use the cord for carrying, pulling or unplugging the power tool. Keep cord away from heat, oil, sharp edges or moving parts.** Damaged or entangled cords increase the risk of electric shock.
- **When operating a power tool outdoors, use an extension cord suitable for outdoor use.** Use of a cord suitable for outdoor use reduces the risk of electric shock.
- **If operating a power tool in a damp location is unavoidable, use a ground fault circuit interrupter (GFCI) protected supply.** Use of an GFCI reduces the risk of electric shock.

### PERSONAL SAFETY

- **Stay alert, watch what you are doing and use common sense when operating a power tool. Do not use a power tool while you are tired or under the influence of drugs, alcohol or medication.** A moment of inattention while operating power tools may result in serious personal injury.
- **Use personal protective equipment. Always wear eye protection.** Protective equipment such as a dust mask, non-skid safety shoes, hard hat or hearing protection used for appropriate conditions will reduce personal injuries.
- **Prevent unintentional starting. Ensure the switch is in the off-position before connecting to power source and/or battery pack, picking up or carrying the tool.** Carrying power tools with your finger on the switch or energizing power tools that have the switch on invites accidents.
- **Remove any adjusting key or wrench before turning the power tool on.** A wrench or a key left

attached to a rotating part of the power tool may result in personal injury.

- **Do not overreach. Keep proper footing and balance at all times.** This enables better control of the power tool in unexpected situations.
- **Dress properly. Do not wear loose clothing or jewelry. Keep your hair and clothing away from moving parts.** Loose clothes, jewelry or long hair can be caught in moving parts.
- **If devices are provided for the connection of dust extraction and collection facilities, ensure these are connected and properly used.** Use of dust collection can reduce dust-related hazards.
- **Do not let familiarity gained from frequent use of tools allow you to become complacent and ignore tool safety principles.** A careless action can cause severe injury within a fraction of a second.

### POWER TOOL USE AND CARE

- **Do not force the power tool. Use the correct power tool for your application.** The correct power tool will do the job better and safer at the rate for which it was designed.
  - **Do not use the power tool if the switch does not turn it on and off.** Any power tool that cannot be controlled with the switch is dangerous and must be repaired.
  - **Disconnect the plug from the power source and/or remove the battery pack, if detachable, from the power tool before making any adjustments, changing accessories, or storing power tools.** Such preventive safety measures reduce the risk of starting the power tool accidentally.
  - **Store idle power tools out of the reach of children and do not allow persons unfamiliar with the power tool or these instructions to operate the power tool.** Power tools are dangerous in the hands of untrained users.
  - **Maintain power tools and accessories. Check for misalignment or binding of moving parts, breakage of parts and any other condition that may affect the power tool's operation. If damaged, have the power tool repaired before use.** Many accidents are caused by poorly maintained power tools.
  - **Keep cutting tools sharp and clean.** Properly maintained cutting tools with sharp cutting edges are less likely to bind and are easier to control.
  - **Use the power tool, accessories and tool bits etc. in accordance with these instructions, taking into account the working conditions and the work to be performed.** Use of the power tool for operations different from those intended could result in a hazardous situation.
  - **Keep handles and grasping surfaces dry, clean and free from oil and grease.** Slippery handles and grasping surfaces do not allow for safe handling and control of the tool in unexpected situations.
- ### BATTERY TOOL USE AND CARE
- **Recharge only with the charger specified by the manufacturer.** A charger that is suitable for one type of battery pack may create a risk of fire when used with another battery pack.
  - **Use power tools only with specifically designated battery packs.** Use of any other battery packs may create a risk of injury and fire.
  - **When battery pack is not in use, keep it away from other metal objects, like paper clips, coins, keys, nails, screws or other small metal objects, that can make a connection from one terminal**

to another. Shorting the battery terminals together may cause burns or a fire.

- **Under abusive conditions, liquid may be ejected from the battery; avoid contact. If contact accidentally occurs, flush with water. If liquid contacts eyes, additionally seek medical help.** Liquid ejected from the battery may cause irritation or burns.
- **Do not use a battery pack or tool that is damaged or modified.** Damaged or modified batteries may exhibit unpredictable behavior resulting in fire, explosion or risk of injury.
- **Do not expose a battery pack or tool to fire or excessive temperature.** Exposure to fire or temperature above 265°F (130°C) may cause explosion.
- **Follow all charging instructions and do not charge the battery pack or tool outside the temperature range specified in the instructions.** Charging improperly or at temperatures outside the specified range may damage the battery and increase the risk of fire.

### SERVICE

- **Have your power tool serviced by a qualified repair person using only identical replacement parts.** This will ensure that the safety of the power tool is maintained.
- **Never service damaged battery packs.** Service of battery packs should only be performed by the manufacturer or authorized service providers.

### SPECIFIC SAFETY RULES FOR PLATE COMPACTOR















- **⚠️ WARNING** To reduce the risk of injury, wear protective footwear when operating the plate compactor.
- **Always wear hearing protection. Wear appropriate respiratory protection and eye protection.**
- **The declared noise emission level represents the main applications of the tool. However if the tool is used for different applications, with different accessories or poorly maintained, the noise emission may differ.**
- **Always set up and park on a flat, level surface.**
- **Stay above the machine when on a sloped surface.**
- **Pay close attention to side walls during trench applications. Unstable walls may collapse due to vibration from the machine.**
- **Follow site rules and regulations.**
- **Keeps hands and feet away from moving parts.**
- **Never use machine when belt guard is not installed.**
- **Do not use accessories which are not specifically designed and specified by the tool manufacturer.** Just because the accessory can be attached to your machine, it does not assure safe operation.
- **Do not operate machine with battery locked in place. Only lock for storage.**
- **Chemical Burn Hazard. Keep coin cell battery away from children.**
- **Always use common sense and be cautious when using tools.** It is not possible to anticipate every situation that could result in a dangerous outcome. Do not use this tool if you do not understand these operating instructions or you feel the work is beyond your capability; contact Milwaukee Tool or a trained professional for additional information or training.
- **Maintain labels and nameplates.** These carry important information. If unreadable or missing, contact a MILWAUKEE service facility for a free replacement.

• **⚠️ WARNING** Some dust created by power sanding, sawing, grinding, drilling, and other construction activities contains chemicals known to cause cancer, birth defects or other reproductive harm. Some examples of these chemicals are:

- lead from lead-based paint
- crystalline silica from bricks and cement and other masonry products, and
- arsenic and chromium from chemically-treated lumber.

Your risk from these exposures varies, depending on how often you do this type of work. To reduce your exposure to these chemicals: work in a well ventilated area, and work with approved safety equipment, such as those dust masks that are specially designed to filter out microscopic particles.

### SYMBOLGY

	Volts
	Direct Current
	<b>⚠️ WARNING</b> Risk of Electric Shock
	Read Operator's Manual
	Wear hearing protection. Wear appropriate respiratory protection and eye protection.
	Surface is hot. Avoid contact.
	Keep body parts away from moving parts.
	Pinch hazard. Keep body parts away from hinge and lift point during folding and unfolding of the handle.
	Guaranteed Sound Power*
	Use lifting point.
	Do not lift with forks.
	Do not lift with excavator bucket.
	Lifting Weight**
	UL Listing for Canada and U.S.

\* See on-product marking for decibel rating.

\*\* Lifting weight includes the weight of the tool and heaviest expected accessories. Always add in the weight of the battery pack if installed during lift.

## FUNCTIONAL DESCRIPTION

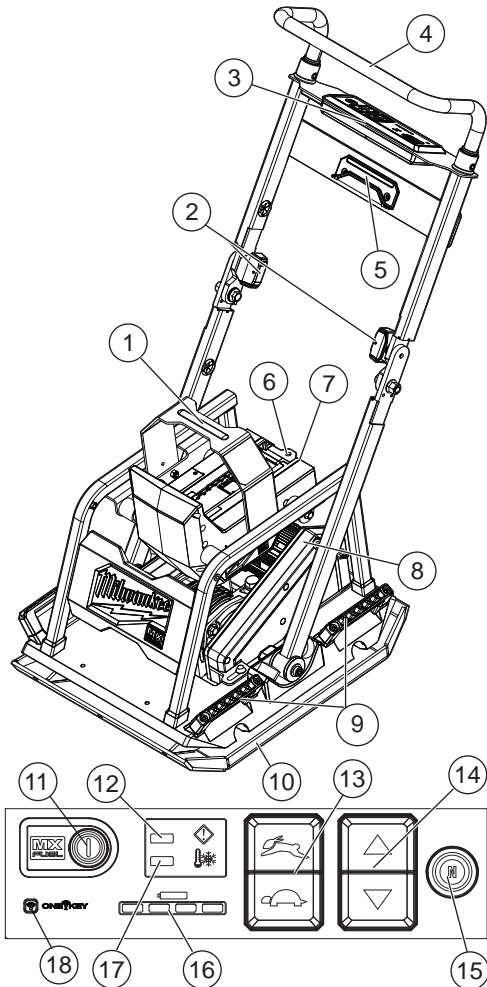

1. Lifting point
2. Handle locking knobs (2)
3. Control panel
4. Handle
5. Clip
6. Battery lock
7. ONE-KEY™ card
8. Belt guard
9. Transport handles (4) (also on reverse side of tool)
10. Compacting plate
11. Arm button
12. Overload indicator
13. Speed control buttons
14. Forward/Reverse buttons
15. Neutral button (stop)
16. Fuel gauge
17. Low temperature indicator
18. ONE-KEY™ indicator

## SPECIFICATIONS

Cat. No.....	MXF220
Battery Type.....	MX FUEL™
Charger Type.....	MX FUEL™
Max Recommended Slope Operation .....	25°
Replacement belt.....	3VX250
Lifting weight.....	225 lbs**
Module/FCC ID.....	BGM11S/QOQ11
Recommended Ambient Operating Temperature.....	0°F to 125°F

## ASSEMBLY

**⚠ WARNING** Recharge only with the charger specified for the battery. For specific charging instructions, read the operator's manual supplied with your charger and battery.

### Removing/Inserting the Battery

To **remove** the battery, push the battery latch lock to the side and squeeze the battery latch lever. Pull the battery pack away from the machine.

**⚠ WARNING** Always remove battery pack before changing or removing accessories.

To **insert** the battery, slide the pack into the body of the machine. Make sure it latches securely into place.

**⚠ WARNING** Only use accessories specifically recommended by the machine manufacturer. Others may be hazardous. Just because the accessory can be attached to this machine, it does not assure safe operation.

### Fuel Gauge

When the machine is armed, the fuel gauge displays the battery pack's remaining run time. The fuel gauge mirrors the fuel gauge on the battery pack. When less than 10% of charge is left, 1 light on the fuel gauge will flash. When the battery reaches 0% charge, the fuel gauge will flash 8 times. Charge the battery pack.

10-32%

32-55%

55-77%

77-100%

Less than 10% if first light flashes 4 times

### Unfolding/Folding the Handle

**⚠ CAUTION** Pinch hazard. Keep body parts away from hinge, lifting point and control panel during folding and unfolding of the handle.

To **avoid** the risk of injury, do not operate the machine with the handle locking knobs unlocked.

For operating position:

1. To **unfold** the handle, turn both handle locking knobs to the unlock position (1).
2. Pull the clip away approximately an inch from the lifting point (2).

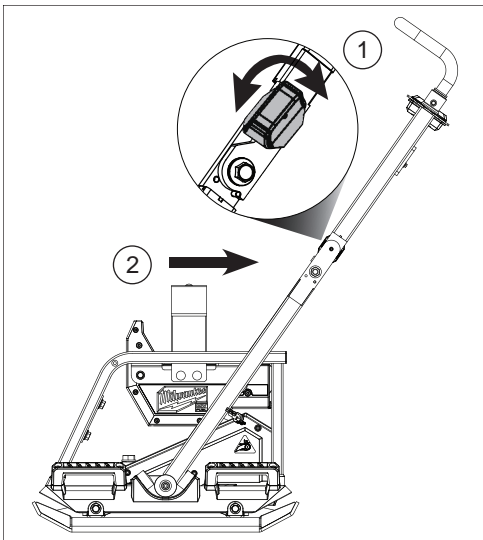

3. Lift the handle to the upright position.
  4. Turn handle locking knobs to lock handle.
- For storage position:

1. **WARNING!** Remove battery to avoid starting the machine.
2. To fold the handle, turn both the handle locking knobs to the unlock position (3).

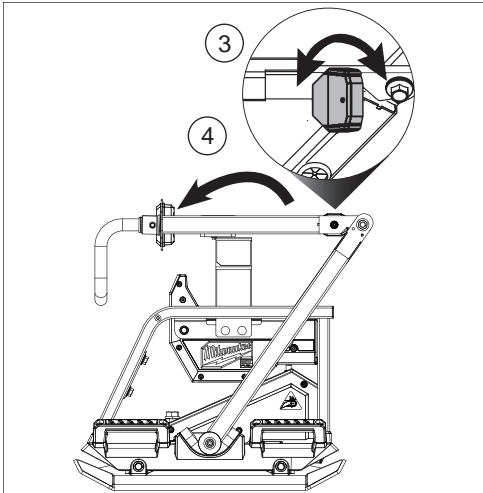

3. Push the handle down on the machine.
4. Secure the clip to the lifting point for transport and storage (4).

## Hoisting with a device

**WARNING** To reduce the risk of injury from a falling machine, do not lift with forks. Do not lift with an excavator bucket. Only hoist machine with undamaged lifting gear rated for the application.

Unarm or remove battery to avoid starting the machine.

Fold the handle in storage position. To hoist the machine, use the lifting point as the anchor point (see Functional Description). Ensure the hoisting strap will not slip or contact other parts.

## Lifting with Transport Handles

**WARNING** Use multiple people whenever it is necessary to lift or carry the machine. Machine is heavy. Lift with legs, not back. 

Always remove the battery pack from the machine before transporting.

Do not hold or carry battery pack by accessory handle while installed in machine.

Always clear the area of obstructions before transporting. To reduce the risk of injury, secure the machine before transporting to prevent tipping, rolling, slipping and falling.

Unarm or remove battery to avoid starting the machine.

Maintain firm footing and always use multiple people to lift when not using a device. To lift, grasp the transport handles. Have additional people grasp the respective side transport handles. Always maintain a firm footing.

## Transporting with a Vehicle

**WARNING!** Unarm or remove battery to avoid starting the machine. Fold the handle in storage position. Using suitable tie downs secure the plate compactor within the transport vehicle using transport handles as tie downs.

## ONE-KEY™

ONE-KEY™ functionality is enabled on this machine by a replaceable card. Removal of this card will disable ONE-KEY™ functionality on the machine. Removal of the card after adding the machine to your inventory in the ONE-KEY™ app will put the machine in a security lockout. Reinsert the card to unlock the machine.

The ONE-KEY™ card can be accessed by removing the cover with a T9 screwdriver.

To learn more about the ONE-KEY™ functionality for this machine, go to [milwaukeeetool.com/One-Key](http://milwaukeeetool.com/One-Key). To download the ONE-KEY™ app, visit the App Store® or Google Play™ from your smart device.

ONE-KEY™ Indicator	
Solid Blue	Wireless mode is active and ready to be configured via the ONE-KEY™ app.
Blinking Blue	Machine is actively communicating with the ONE-KEY™ app.
Blinking Red	Machine is in security lockout and can be unlocked by the owner via the ONE-KEY™ app.



## OPERATION

**WARNING** To reduce the risk of injury, always wear proper eye protection marked to comply with ANSI Z87.1.

When working in dusty situations, wear appropriate respiratory protection or use an OSHA compliant dust extraction solution.

Wear protective footwear when operating the plate compactor.

Wear ear protectors. Exposure to noise can cause hearing loss.

Never use machine when belt guard is not installed.

### Arming the Machine

The MX FUEL™ machines must be armed prior to use. Even with the battery pack inserted, the trigger and machine functions will not operate until the machine armed.

To arm the machine:

1. Insert the battery pack.
2. Press the arm button. The MX FUEL™ icon will light. The trigger will become armed in 2 seconds.
3. After 15 minutes of inactivity, the machine will enter sleep mode. The MX FUEL™ icon will go off and the trigger and LEDs are un-operational.
4. Press and hold the arm button for 1 second to reactivate the machine.
5. Press and hold the arm button for 1 second to unarm (turn off) the machine. The MX FUEL™ icon will go off.

### Operating the Plate Compactor

**WARNING** Crush hazard. To reduce the risk of serious injury:

- Always be sure of your footing. A slip and fall can cause serious personal injury.
- Do not operate on slopes above recommended angle. See "Specifications". Stay above the machine when on a sloped surface.
- Pay close attention to trench side walls, trenches, changing ground conditions, structures and uneven ground. Unstable walls may collapse due to vibration from the machine.
- Use caution when operating near pits, ditches, or plateaus. Ensure the ground has the adequate load-bearing capacity to support the weight of the machine and operator.
- If you lose control of the machine, do not try to stop the machine.

The plate compactor is intended to be used for compacting in earth, gravel, mixed soils, and asphalt. Check for loose fasteners or damaged parts before operating the machine. Do not operate the plate compactor with loose fasteners, damaged parts, or standing water in the lower plate. To prevent the machine from going into low temperature, tip out water before operating the machine.

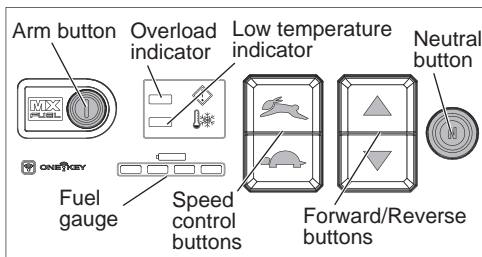

1. Ensure accessories are securely attached, if applicable.
2. To turn on the machine, arm the machine.
3. Set the speed and direction. The plate compactor will move once direction is selected.
4. Guide the machine in the desired direction.
5. To stop the machine from moving, push the neutral button.
6. To reverse the direction of movement, after stopping the machine, set the handle to the desired position and push the machine opposite direction.
7. To turn off the machine, unarm the machine.
8. **WARNING!** Remove battery to avoid starting the machine.
9. After each use, **clean** the machine by tipping it over to remove dirt, stones, and mud between the lower and upper plates. Use an air hose or pressure washer, if needed.

### Overload Indicator

The overload indicator will illuminate when the machine is operating near the thermal limit. The machine is able to continue operating during this time.

The overload indicator will blink when the machine has reached the thermal limit and is cooling down. While the overload indicator is blinking, the machine is not able to operate. Once the machine has cooled the overload indicator will stop blinking and the machine can operate.

### Low Temperature Indicator

The low temperature indicator will blink when the machine is not able to start due to low operating temperatures. While the low temperature indicator is blinking the machine will operate at a slow speed to warm up the machine. Ensure there is no standing water in the plate. Tip out any water in the plate compactor. Continue using the machine at a slower rate in temperatures less than 32°F. Once warmed up, the machine will resume normal operation at selected speed and the low temperature indicator will stop blinking. If the machine is not able to resume normal operation, it will stay in neutral. Check belt tension if problem persists.

## MAINTENANCE

**WARNING** To reduce the risk of injury, always unplug the charger and remove the battery pack from the charger or machine before performing any maintenance. Never disassemble the battery pack, charger, or machine, except as provided in these instructions. Contact a MILWAUKEE service facility for all other repairs.

### Maintaining Machine

Keep your machine, battery pack and charger in good repair by adopting a regular maintenance program. Inspect your machine for issues such as undue noise, misalignment or binding of moving parts, breakage of parts, or any other condition that may affect the machine operation. Return the machine, battery pack, and charger to a MILWAUKEE service facility for repair. After six months to one year, depending on use, return the machine, battery pack and charger to a MILWAUKEE service facility for inspection.

If the machine does not start or operate at full power with a fully charged battery pack, clean the contacts on the battery pack. If the machine still does not work properly, return the machine, charger and battery pack, to a MILWAUKEE service facility for repairs.

### Removing/Installing the Belt

Check belt annually for cracking, crazing, glazing, or fraying or other signs of wear. Replace belt when damaged or poor performance occurs. Refer to specifications for replacement belt.

1. **WARNING!** Remove battery to avoid starting the machine.

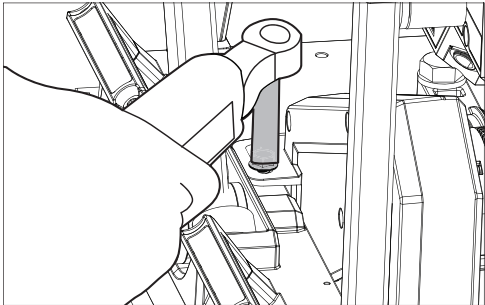

2. To remove the belt, using a 13 mm socket wrench remove one M8 flange bolt located at the front of the belt guard.
3. Using a 4 mm hex wrench loosen the four screws holding the belt guard.
4. Remove the belt guard.

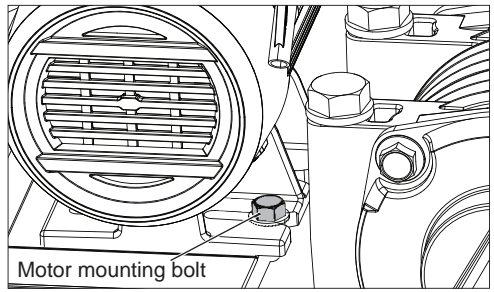
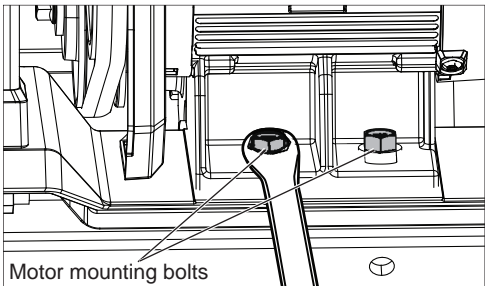

5. Using a 13 mm wrench loosen the two motor mounting bolts located behind and one in front of the motor. This will help the motor slide towards the front of the machine.
6. Remove the belt.
7. Install a new belt in the "V" groove of both pulleys.
8. Pull back on the motor to tension the belt. Correct tension is when the belt deflects 1/2" with heavy thumb pressure.
9. Tighten each motor mounting bolts using a calibrated device torque to 21.5 ft-lbs. This will help prevent the motor from sliding.
10. Check belt tension to ensure shifting did not occur during tightening.
11. Install belt guard.
12. Hand tighten the belt guard screws. Using a calibrated device torque M8 flange bolt to 7.4 ft-lbs.

### ONE-KEY™

**WARNING** Chemical Burn Hazard. This device contains a lithium button/coin cell battery. A new or used battery can cause severe internal burns and lead to death in as little as 2 hours if swallowed or enters the body. Always secure the battery cover. If it does not close securely, stop using the device, remove the batteries, and keep it away from children. If you think batteries may have been swallowed or entered the body, seek immediate medical attention.



### Internal Coin Cell Battery

An internal coin cell battery is used to facilitate full ONE-KEY™ functionality.

If the Mode Indicator LED turns off and the machine cannot adjust speed, or if the Bluetooth communication stops working, remove and reinsert the coin cell battery to reset. Replace the battery if the problem continues.

To replace the coin cell battery:

1. **WARNING!** Remove battery to avoid starting the machine.
2. Loosen the screw(s) and open the coin cell battery door.
3. Remove the old coin cell battery, keep it away from children, and dispose of it properly.
4. Insert the new coin cell battery (3V CR2032), with the positive side facing up.
5. Close the battery door and tighten the screw(s) securely.

**⚠WARNING** To reduce the risk of personal injury, electric shock and damage, never immerse your machine in liquid or allow a liquid to flow inside it.

### Cleaning

Allow the motor to cool before cleaning. When the motor has cooled, remove all debris from the machine. Use only mild soap and a damp cloth to clean, since certain cleaning agents and solvents are harmful to plastics and other insulated parts. Some of these include gasoline, turpentine, lacquer thinner, paint thinner, chlorinated cleaning solvents, ammonia and household detergents containing ammonia. Do not spray the machine or battery. Never use flammable or combustible solvents around machines. Keep machine clean, dry and free of oil or grease. Keep battery connections and surfaces between the machine and battery free of debris and materials. Failure to keep surfaces clean may result in misalignment and/or damage to the battery connection.

### Repairs

For repairs, return the machine to the nearest authorized service center.

## ACCESSORIES

**⚠WARNING** Use only recommended accessories. Others may be hazardous.

For a complete listing of accessories, go online to [www.milwaukeetool.com](http://www.milwaukeetool.com) or contact a distributor.

## WIRELESS COMMUNICATION

For products provided with wireless communication features, including ONE-KEY™:

Pursuant to part 15.21 of the FCC Rules, do not modify this product. Modification could void your authority to operate the product. This device complies with part 15 of the FCC Rules and ISED-Canada's license exempt RSS standards. Operation is subject to the following two conditions: 1) This device may not cause harmful interference, and 2) This device must accept any interference received, including interference that may cause undesired operation.

## SERVICE - UNITED STATES

**1-800-SAWDUST** (1.800.729.3878)

Monday-Friday, 7:00 AM - 6:30 PM CST  
or visit [www.milwaukeetool.com](http://www.milwaukeetool.com)

Contact Corporate After Sales Service Technical Support with technical, service/repair, or warranty questions.

Email: [metproductsupport@milwaukeetool.com](mailto:metproductsupport@milwaukeetool.com)

Become a Heavy Duty Club Member at [www.milwaukeetool.com](http://www.milwaukeetool.com) to receive important notifications regarding your purchases.

## SERVICE - CANADA

**Milwaukee Tool (Canada) Ltd**  
**1.877.948.2360**

Monday-Friday, 7:00 AM - 4:30 PM CST  
or visit [www.milwaukeetool.ca](http://www.milwaukeetool.ca)

## LIMITED WARRANTY USA & CANADA

Every MILWAUKEE MX FUEL™ Product, battery pack, and charger is warranted to the original purchaser from an authorized MILWAUKEE distributor only to be free from defects in material and workmanship. Subject to certain exceptions, MILWAUKEE will repair or replace a MX FUEL™ product, battery pack, or charger which, after examination, is determined by MILWAUKEE to be defective in material or workmanship for a period of two (2) years after the date of purchase. Return of the MX FUEL™ product, battery pack, or charger to a MILWAUKEE factory Service Center location or MILWAUKEE Authorized Service Station, freight prepaid and insured, is required. For the proper shipping procedure of battery packs, contact 1.800.SAWDUST (1.800.729.3878), or go to [www.milwaukeetool.com](http://www.milwaukeetool.com). A copy of the proof of purchase should be included with the return product. This warranty does not apply to damage that MILWAUKEE determines to be from repairs made or attempted by anyone other than MILWAUKEE authorized personnel, misuse, alterations, abuse, normal wear and tear, lack of maintenance, or accidents.

Normal Wear: Many MX FUEL™ products need periodic parts replacement and service to achieve best performance. This warranty does not cover repair when normal use has exhausted the life of a part including, but not limited to, assist & drive belts, pulleys, blade flanges, vacuum gaskets, tool free handles, set pins, skis, drive couplers, rubber boots, auto feed, stabilize blocks, wheels, carrier wheels, cords, o-rings, seals, bumpers, driver blades, pistons, strikers, lifters, tool holder, and bumper cover washers.

Warranty Registration is not necessary to obtain the applicable warranty on a MX FUEL™ product, battery pack, or charger.

ACCEPTANCE OF THE EXCLUSIVE REPAIR AND REPLACEMENT REMEDIES DESCRIBED HEREIN IS A CONDITION OF THE CONTRACT FOR THE PURCHASE OF EVERY MILWAUKEE PRODUCT. IF YOU DO NOT AGREE TO THIS CONDITION, YOU SHOULD NOT PURCHASE THE PRODUCT. IN NO EVENT SHALL MILWAUKEE BE LIABLE FOR ANY INCIDENTAL, SPECIAL, CONSEQUENTIAL, OR PUNITIVE DAMAGES, OR FOR ANY COSTS, ATTORNEY FEES, EXPENSES, LOSSES OR DELAYS ALLEGED TO BE AS A CONSEQUENCE OF ANY DAMAGE TO, FAILURE OF, OR DEFECT IN ANY PRODUCT INCLUDING, BUT NOT LIMITED TO, ANY CLAIMS FOR LOSS OF PROFITS. SOME STATES DO NOT ALLOW THE EXCLUSION OR LIMITATION OF INCIDENTAL OR CONSEQUENTIAL DAMAGES, SO THE ABOVE LIMITATION OR EXCLUSION MAY NOT APPLY TO YOU. THIS WARRANTY IS EXCLUSIVE AND IN LIEU OF ALL OTHER EXPRESS WARRANTIES, WRITTEN OR ORAL, TO THE EXTENT PERMITTED BY LAW, MILWAUKEE DISCLAIMS ANY IMPLIED WARRANTIES, INCLUDING WITHOUT LIMITATION ANY IMPLIED WARRANTY OF MERCHANTABILITY OR FITNESS FOR A PARTICULAR USE OR PURPOSE; TO THE EXTENT SUCH DISCLAIMER IS NOT PERMITTED BY LAW, SUCH IMPLIED WARRANTIES ARE LIMITED TO THE DURATION OF THE APPLICABLE EXPRESS WARRANTY AS DESCRIBED ABOVE. SOME STATES DO NOT ALLOW LIMITATIONS ON HOW LONG AN IMPLIED WARRANTY LASTS, SO THE ABOVE LIMITATION MAY NOT APPLY TO YOU, THIS WARRANTY GIVES YOU SPECIFIC LEGAL RIGHTS, AND YOU MAY ALSO HAVE OTHER RIGHTS WHICH VARY FROM STATE TO STATE.

This warranty applies to product sold in the U.S.A. and Canada only. Please consult the 'Service Center Search' in the Parts & Service section of MILWAUKEE's website [www.milwaukeetool.com](http://www.milwaukeetool.com) or call 1.800.SAWDUST (1.800.729.3878) to locate your nearest service facility for warranty and non-warranty service on a MX FUEL™ product, battery pack or charger.