



[Click Here To View](#)
[Item at](#)

www.GapPower.com

*Sales • Rentals
Parts & Service*



OM-225 311C

2007-05

Processes



MIG (GMAW) Welding

Flux Cored (FCAW) Welding

Description



Arc Welding Power Source And Wire Feeder

Millermatic[®] 140, 140 Auto-Set[™], And 180 And M-10 Gun

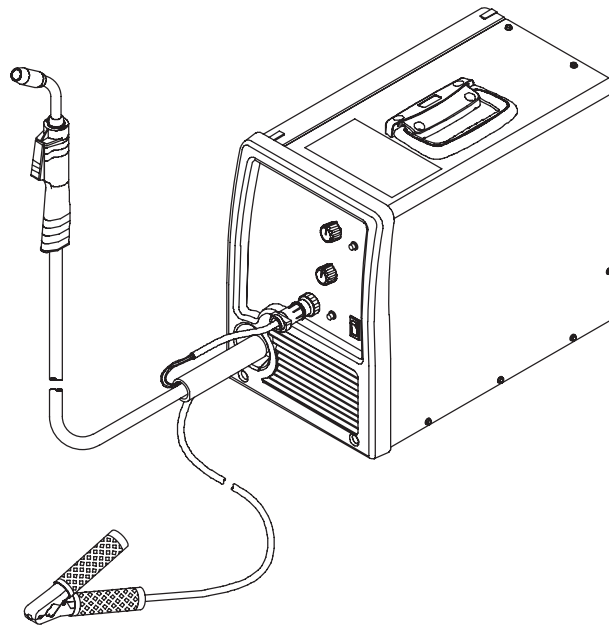

Visit our website at
www.MillerWelds.com

OWNER'S MANUAL

File: MIG (GMAW)



From Miller to You

Thank you and congratulations on choosing Miller. Now you can get the job done and get it done right. We know you don't have time to do it any other way.

That's why when Niels Miller first started building arc welders in 1929, he made sure his products offered long-lasting value and superior quality. Like you, his customers couldn't afford anything less. Miller products had to be more than the best they could be. They had to be the best you could buy.

Today, the people that build and sell Miller products continue the tradition. They're just as committed to providing equipment and service that meets the high standards of quality and value established in 1929.

This Owner's Manual is designed to help you get the most out of your Miller products. Please take time to read the Safety precautions. They will help you protect yourself against potential hazards on the worksite.

We've made installation and operation quick and easy. With Miller you can count on years of reliable service with proper maintenance. And if for some reason the unit needs repair, there's a Troubleshooting section that will help you figure out what the problem is. The parts list will then help you to decide the exact part you may need to fix the problem. Warranty and service information for your particular model are also provided.



Miller is the first welding equipment manufacturer in the U.S.A. to be registered to the ISO 9001:2000 Quality System Standard.



Miller Electric manufactures a full line of welders and welding related equipment. For information on other quality Miller products, contact your local Miller distributor to receive the latest full line catalog or individual specification sheets. **To locate your nearest distributor or service agency call 1-800-4-A-Miller, or visit us at www.MillerWelds.com on the web.**



Working as hard as you do – every power source from Miller is backed by the most hassle-free warranty in the business.



TABLE OF CONTENTS

SECTION 1 – SAFETY PRECAUTIONS - READ BEFORE USING	1
1-1. Symbol Usage	1
1-2. Arc Welding Hazards	1
1-3. Additional Symbols For Installation, Operation, And Maintenance	3
1-4. California Proposition 65 Warnings	3
1-5. Principal Safety Standards	4
1-6. EMF Information	4
SECTION 2 – CONSIGNES DE SÉCURITÉ – LIRE AVANT UTILISATION	5
2-1. Symboles utilisés	5
2-2. Dangers relatifs au soudage à l'arc	5
2-3. Dangers supplémentaires en relation avec l'installation, le fonctionnement et la maintenance	7
2-4. Proposition californienne 65 Avertissements	7
2-5. Principales normes de sécurité	8
2-6. Information EMF	8
SECTION 3 – SPECIFICATIONS	9
3-1. Specifications	9
3-2. Duty Cycle And Overheating	10
3-3. Volt-Ampere Curves	11
SECTION 4 – INSTALLATION	12
4-1. Installing Welding Gun	12
4-2. Installing Work Clamp	12
4-3. Work Cable Routing Inside Unit	13
4-4. Process/Polarity Table	13
4-5. Changing Polarity	13
4-6. Installing Gas Supply	14
4-7. Selecting A Location And Connecting Input Power For 115 VAC Model	15
4-8. Selecting A Location And Connecting Input Power For 230 VAC Model	16
4-9. Electrical Service Guide For 230 VAC Model	17
4-10. Installing Wire Spool And Adjusting Hub Tension	17
4-11. Threading Welding Wire	18
4-12. Removing MIG Gun From Welding Power Source	19
4-13. Installing Optional Spool Gun Switch In Welding Power Source	20
4-14. Connecting Spool Gun To Milleromatic 140/180	21
SECTION 5 – OPERATION	22
5-1. Controls For 115 VAC Model w/Auto-Set™	22
5-2. Controls For 115 VAC Model	23
5-3. Controls For 230 VAC Model	24
5-4. Weld Parameter Chart For 115 VAC Model w/Auto-Set™	26
5-5. Weld Parameter Chart For 115 VAC Model w/Factory Set Non-Wire Speed Tracking Mode	28
5-6. Weld Parameter Chart For 115 VAC Model w/Wire Speed Tracking Mode	30
5-7. Weld Parameter Chart For 230 VAC Model w/Factory Set Non-Wire Speed Tracking Mode	32
5-8. Weld Parameter Chart For 230 VAC Model w/Wire Speed Tracking Mode	34

TABLE OF CONTENTS

SECTION 6 – MAINTENANCE & TROUBLESHOOTING	36
6-1. Routine Maintenance	36
6-2. Overload Protection	36
6-3. Drive Motor Protection And Tip Saver/Short Circuit Protection	36
6-4. Changing Drive Roll Or Wire Inlet Guide	37
6-5. Replacing Gun Contact Tip	37
6-6. Cleaning Or Replacing Gun Liner	38
6-7. Replacing Switch And/Or Head Tube	39
6-8. Troubleshooting Table	40
SECTION 7 – ELECTRICAL DIAGRAM	42
SECTION 8 – MIG WELDING (GMAW) GUIDELINES	44
8-1. Typical MIG Process Connections	44
8-2. Typical MIG Process Control Settings	45
8-3. Holding And Positioning Welding Gun	46
8-4. Conditions That Affect Weld Bead Shape	47
8-5. Gun Movement During Welding	48
8-6. Poor Weld Bead Characteristics	48
8-7. Good Weld Bead Characteristics	48
8-8. Troubleshooting – Excessive Spatter	49
8-9. Troubleshooting – Porosity	49
8-10. Troubleshooting – Excessive Penetration	50
8-11. Troubleshooting – Lack Of Penetration	50
8-12. Troubleshooting – Incomplete Fusion	50
8-13. Troubleshooting – Burn-Through	51
8-14. Troubleshooting – Waviness Of Bead	51
8-15. Troubleshooting – Distortion	51
8-16. Common MIG Shielding Gases	52
SECTION 9 – PARTS LIST	53
WARRANTY	

SECTION 1 – SAFETY PRECAUTIONS - READ BEFORE USING

som _3/05

▲ **Warning: Protect yourself and others from injury — read and follow these precautions.**

1-1. Symbol Usage



Means Warning! Watch Out! There are possible hazards with this procedure! The possible hazards are shown in the adjoining symbols.

▲ **Marks a special safety message.**

☞ Means “Note”; not safety related.



This group of symbols means Warning! Watch Out! possible ELECTRIC SHOCK, MOVING PARTS, and HOT PARTS hazards. Consult symbols and related instructions below for necessary actions to avoid the hazards.

1-2. Arc Welding Hazards

▲ **The symbols shown below are used throughout this manual to call attention to and identify possible hazards. When you see the symbol, watch out, and follow the related instructions to avoid the hazard. The safety information given below is only a summary of the more complete safety information found in the Safety Standards listed in Section 1-5. Read and follow all Safety Standards.**

▲ **Only qualified persons should install, operate, maintain, and repair this unit.**

▲ **During operation, keep everybody, especially children, away.**



ELECTRIC SHOCK can kill.

Touching live electrical parts can cause fatal shocks or severe burns. The electrode and work circuit is electrically live whenever the output is on. The input power circuit and machine internal circuits are also

live when power is on. In semiautomatic or automatic wire welding, the wire, wire reel, drive roll housing, and all metal parts touching the welding wire are electrically live. Incorrectly installed or improperly grounded equipment is a hazard.

- Do not touch live electrical parts.
- Wear dry, hole-free insulating gloves and body protection.
- Insulate yourself from work and ground using dry insulating mats or covers big enough to prevent any physical contact with the work or ground.
- Do not use AC output in damp areas, if movement is confined, or if there is a danger of falling.
- Use AC output ONLY if required for the welding process.
- If AC output is required, use remote output control if present on unit.
- Additional safety precautions are required when any of the following electrically hazardous conditions are present: in damp locations or while wearing wet clothing; on metal structures such as floors, gratings, or scaffolds; when in cramped positions such as sitting, kneeling, or lying; or when there is a high risk of unavoidable or accidental contact with the workpiece or ground. For these conditions, use the following equipment in order presented: 1) a semiautomatic DC constant voltage (wire) welder, 2) a DC manual (stick) welder, or 3) an AC welder with reduced open-circuit voltage. In most situations, use of a DC, constant voltage wire welder is recommended. And, do not work alone!
- Disconnect input power or stop engine before installing or servicing this equipment. Lockout/tagout input power according to OSHA 29 CFR 1910.147 (see Safety Standards).
- Properly install and ground this equipment according to its Owner's Manual and national, state, and local codes.
- Always verify the supply ground – check and be sure that input power cord ground wire is properly connected to ground terminal in disconnect box or that cord plug is connected to a properly grounded receptacle outlet.
- When making input connections, attach proper grounding conductor first – double-check connections.
- Frequently inspect input power cord for damage or bare wiring – replace cord immediately if damaged – bare wiring can kill.

- Turn off all equipment when not in use.
- Do not use worn, damaged, undersized, or poorly spliced cables.
- Do not drape cables over your body.
- If earth grounding of the workpiece is required, ground it directly with a separate cable.
- Do not touch electrode if you are in contact with the work, ground, or another electrode from a different machine.
- Do not touch electrode holders connected to two welding machines at the same time since double open-circuit voltage will be present.
- Use only well-maintained equipment. Repair or replace damaged parts at once. Maintain unit according to manual.
- Wear a safety harness if working above floor level.
- Keep all panels and covers securely in place.
- Clamp work cable with good metal-to-metal contact to workpiece or worktable as near the weld as practical.
- Insulate work clamp when not connected to workpiece to prevent contact with any metal object.
- Do not connect more than one electrode or work cable to any single weld output terminal.

SIGNIFICANT DC VOLTAGE exists in inverter-type welding power sources after removal of input power.

- Turn Off inverter, disconnect input power, and discharge input capacitors according to instructions in Maintenance Section before touching any parts.

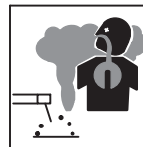

FUMES AND GASES can be hazardous.

Welding produces fumes and gases. Breathing these fumes and gases can be hazardous to your health.

- Keep your head out of the fumes. Do not breathe the fumes.
- If inside, ventilate the area and/or use local forced ventilation at the arc to remove welding fumes and gases.
- If ventilation is poor, wear an approved air-supplied respirator.
- Read and understand the Material Safety Data Sheets (MSDSs) and the manufacturer's instructions for metals, consumables, coatings, cleaners, and degreasers.
- Work in a confined space only if it is well ventilated, or while wearing an air-supplied respirator. Always have a trained watch-person nearby. Welding fumes and gases can displace air and lower the oxygen level causing injury or death. Be sure the breathing air is safe.
- Do not weld in locations near degreasing, cleaning, or spraying operations. The heat and rays of the arc can react with vapors to form highly toxic and irritating gases.
- Do not weld on coated metals, such as galvanized, lead, or cadmium plated steel, unless the coating is removed from the weld area, the area is well ventilated, and while wearing an air-supplied respirator. The coatings and any metals containing these elements can give off toxic fumes if welded.



ARC RAYS can burn eyes and skin.

Arc rays from the welding process produce intense visible and invisible (ultraviolet and infrared) rays that can burn eyes and skin. Sparks fly off from the weld.

- Wear an approved welding helmet fitted with a proper shade of filter lenses to protect your face and eyes when welding or watching (see ANSI Z49.1 and Z87.1 listed in Safety Standards).
- Wear approved safety glasses with side shields under your helmet.
- Use protective screens or barriers to protect others from flash, glare and sparks; warn others not to watch the arc.
- Wear protective clothing made from durable, flame-resistant material (leather, heavy cotton, or wool) and foot protection.



WELDING can cause fire or explosion.

Welding on closed containers, such as tanks, drums, or pipes, can cause them to blow up. Sparks can fly off from the welding arc. The flying sparks, hot workpiece, and hot equipment can cause fires and burns. Accidental contact of electrode to metal objects can cause sparks, explosion, overheating, or fire. Check and be sure the area is safe before doing any welding.

- Remove all flammables within 35 ft (10.7 m) of the welding arc. If this is not possible, tightly cover them with approved covers.
- Do not weld where flying sparks can strike flammable material.
- Protect yourself and others from flying sparks and hot metal.
- Be alert that welding sparks and hot materials from welding can easily go through small cracks and openings to adjacent areas.
- Watch for fire, and keep a fire extinguisher nearby.
- Be aware that welding on a ceiling, floor, bulkhead, or partition can cause fire on the hidden side.
- Do not weld on closed containers such as tanks, drums, or pipes, unless they are properly prepared according to AWS F4.1 (see Safety Standards).
- Connect work cable to the work as close to the welding area as practical to prevent welding current from traveling long, possibly unknown paths and causing electric shock, sparks, and fire hazards.
- Do not use welder to thaw frozen pipes.
- Remove stick electrode from holder or cut off welding wire at contact tip when not in use.
- Wear oil-free protective garments such as leather gloves, heavy shirt, cuffless trousers, high shoes, and a cap.
- Remove any combustibles, such as a butane lighter or matches, from your person before doing any welding.
- Follow requirements in OSHA 1910.252 (a) (2) (iv) and NFPA 51B for hot work and have a fire watcher and extinguisher nearby.

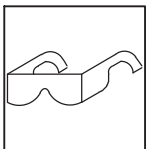

FLYING METAL can injure eyes.

- Welding, chipping, wire brushing, and grinding cause sparks and flying metal. As welds cool, they can throw off slag.
- Wear approved safety glasses with side shields even under your welding helmet.



BUILDUP OF GAS can injure or kill.

- Shut off shielding gas supply when not in use.
- Always ventilate confined spaces or use approved air-supplied respirator.



HOT PARTS can cause severe burns.

- Do not touch hot parts bare handed.
- Allow cooling period before working on gun or torch.
- To handle hot parts, use proper tools and/or wear heavy, insulated welding gloves and clothing to prevent burns.



MAGNETIC FIELDS can affect pacemakers.

- Pacemaker wearers keep away.
- Wearers should consult their doctor before going near arc welding, gouging, or spot welding operations.



NOISE can damage hearing.

Noise from some processes or equipment can damage hearing.

- Wear approved ear protection if noise level is high.



CYLINDERS can explode if damaged.

Shielding gas cylinders contain gas under high pressure. If damaged, a cylinder can explode. Since gas cylinders are normally part of the welding process, be sure to treat them carefully.

- Protect compressed gas cylinders from excessive heat, mechanical shocks, physical damage, slag, open flames, sparks, and arcs.
- Install cylinders in an upright position by securing to a stationary support or cylinder rack to prevent falling or tipping.
- Keep cylinders away from any welding or other electrical circuits.
- Never drape a welding torch over a gas cylinder.
- Never allow a welding electrode to touch any cylinder.
- Never weld on a pressurized cylinder – explosion will result.
- Use only correct shielding gas cylinders, regulators, hoses, and fittings designed for the specific application; maintain them and associated parts in good condition.
- Turn face away from valve outlet when opening cylinder valve.
- Keep protective cap in place over valve except when cylinder is in use or connected for use.
- Use the right equipment, correct procedures, and sufficient number of persons to lift and move cylinders.
- Read and follow instructions on compressed gas cylinders, associated equipment, and Compressed Gas Association (CGA) publication P-1 listed in Safety Standards.

1-3. Additional Symbols For Installation, Operation, And Maintenance



FIRE OR EXPLOSION hazard.

- Do not install or place unit on, over, or near combustible surfaces.
- Do not install unit near flammables.
- Do not overload building wiring – be sure power supply system is properly sized, rated, and protected to handle this unit.



FALLING UNIT can cause injury.

- Use lifting eye to lift unit only, NOT running gear, gas cylinders, or any other accessories.
- Use equipment of adequate capacity to lift and support unit.
- If using lift forks to move unit, be sure forks are long enough to extend beyond opposite side of unit.

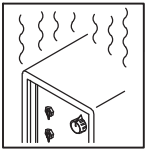

OVERUSE can cause OVERHEATING

- Allow cooling period; follow rated duty cycle.
- Reduce current or reduce duty cycle before starting to weld again.
- Do not block or filter airflow to unit.

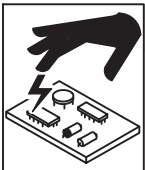

STATIC (ESD) can damage PC boards.

- Put on grounded wrist strap BEFORE handling boards or parts.
- Use proper static-proof bags and boxes to store, move, or ship PC boards.



MOVING PARTS can cause injury.

- Keep away from moving parts.
- Keep away from pinch points such as drive rolls.



WELDING WIRE can cause injury.

- Do not press gun trigger until instructed to do so.
- Do not point gun toward any part of the body, other people, or any metal when threading welding wire.



MOVING PARTS can cause injury.

- Keep away from moving parts such as fans.
- Keep all doors, panels, covers, and guards closed and securely in place.
- Have only qualified persons remove doors, panels, covers, or guards for maintenance as necessary.
- Reinstall doors, panels, covers, or guards when maintenance is finished and before re-connecting input power.

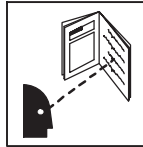

READ INSTRUCTIONS.

- Read Owner's Manual before using or servicing unit.
- Use only genuine Miller/Hobart replacement parts.

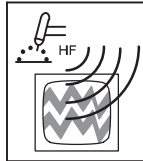

H.F. RADIATION can cause interference.

- High-frequency (H.F.) can interfere with radio navigation, safety services, computers, and communications equipment.
- Have only qualified persons familiar with electronic equipment perform this installation.
- The user is responsible for having a qualified electrician promptly correct any interference problem resulting from the installation.
- If notified by the FCC about interference, stop using the equipment at once.
- Have the installation regularly checked and maintained.
- Keep high-frequency source doors and panels tightly shut, keep spark gaps at correct setting, and use grounding and shielding to minimize the possibility of interference.

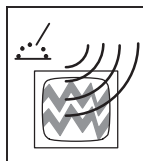

ARC WELDING can cause interference.

- Electromagnetic energy can interfere with sensitive electronic equipment such as computers and computer-driven equipment such as robots.
- Be sure all equipment in the welding area is electromagnetically compatible.
- To reduce possible interference, keep weld cables as short as possible, close together, and down low, such as on the floor.
- Locate welding operation 100 meters from any sensitive electronic equipment.
- Be sure this welding machine is installed and grounded according to this manual.
- If interference still occurs, the user must take extra measures such as moving the welding machine, using shielded cables, using line filters, or shielding the work area.

1-4. California Proposition 65 Warnings

- ▲ Welding or cutting equipment produces fumes or gases which contain chemicals known to the State of California to cause birth defects and, in some cases, cancer. (California Health & Safety Code Section 25249.5 et seq.)
- ▲ Battery posts, terminals and related accessories contain lead and lead compounds, chemicals known to the State of California to cause cancer and birth defects or other reproductive harm. Wash hands after handling.

For Gasoline Engines:

- ▲ Engine exhaust contains chemicals known to the State of California to cause cancer, birth defects, or other reproductive harm.

For Diesel Engines:

- ▲ Diesel engine exhaust and some of its constituents are known to the State of California to cause cancer, birth defects, and other reproductive harm.

1-5. Principal Safety Standards

Safety in Welding, Cutting, and Allied Processes, ANSI Standard Z49.1, from Global Engineering Documents (phone: 1-877-413-5184, website: www.global.ihs.com).

Recommended Safe Practices for the Preparation for Welding and Cutting of Containers and Piping, American Welding Society Standard AWS F4.1 from Global Engineering Documents (phone: 1-877-413-5184, website: www.global.ihs.com).

National Electrical Code, NFPA Standard 70, from National Fire Protection Association, P.O. Box 9101, 1 Battery March Park, Quincy, MA 02269-9101 (phone: 617-770-3000, website: www.nfpa.org).

Safe Handling of Compressed Gases in Cylinders, CGA Pamphlet P-1, from Compressed Gas Association, 1735 Jefferson Davis Highway, Suite 1004, Arlington, VA 22202-4102 (phone: 703-412-0900, website: www.cganet.com).

Code for Safety in Welding and Cutting, CSA Standard W117.2, from Canadian Standards Association, Standards Sales, 178 Rexdale

Boulevard, Rexdale, Ontario, Canada M9W 1R3 (phone: 800-463-6727 or in Toronto 416-747-4044, website: www.csa-international.org).

Practice For Occupational And Educational Eye And Face Protection, ANSI Standard Z87.1, from American National Standards Institute, 11 West 42nd Street, New York, NY 10036-8002 (phone: 212-642-4900, website: www.ansi.org).

Standard for Fire Prevention During Welding, Cutting, and Other Hot Work, NFPA Standard 51B, from National Fire Protection Association, P.O. Box 9101, 1 Battery March Park, Quincy, MA 02269-9101 (phone: 617-770-3000, website: www.nfpa.org).

OSHA, Occupational Safety and Health Standards for General Industry, Title 29, Code of Federal Regulations (CFR), Part 1910, Subpart Q, and Part 1926, Subpart J, from U.S. Government Printing Office, Superintendent of Documents, P.O. Box 371954, Pittsburgh, PA 15250 (there are 10 Regional Offices--phone for Region 5, Chicago, is 312-353-2220, website: www.osha.gov).

1-6. EMF Information

Considerations About Welding And The Effects Of Low Frequency Electric And Magnetic Fields

Welding current, as it flows through welding cables, will cause electromagnetic fields. There has been and still is some concern about such fields. However, after examining more than 500 studies spanning 17 years of research, a special blue ribbon committee of the National Research Council concluded that: "The body of evidence, in the committee's judgment, has not demonstrated that exposure to power-frequency electric and magnetic fields is a human-health hazard." However, studies are still going forth and evidence continues to be examined. Until the final conclusions of the research are reached, you may wish to minimize your exposure to electromagnetic fields when welding or cutting.

To reduce magnetic fields in the workplace, use the following procedures:

1. Keep cables close together by twisting or taping them.
2. Arrange cables to one side and away from the operator.
3. Do not coil or drape cables around your body.
4. Keep welding power source and cables as far away from operator as practical.
5. Connect work clamp to workpiece as close to the weld as possible.

About Pacemakers:

Pacemaker wearers consult your doctor before welding or going near welding operations. If cleared by your doctor, then following the above procedures is recommended.

SECTION 2 – CONSIGNES DE SÉCURITÉ – LIRE AVANT UTILISATION

som _3/05

▲ **Avertissement : se protéger et protéger les autres contre le risque de blessure — lire et respecter ces consignes.**

2-1. Symboles utilisés



Symbole graphique d'avertissement ! Attention ! Cette procédure comporte des risques possibles ! Les dangers éventuels sont représentés par les symboles graphiques joints.



Ce groupe de symboles signifie Avertissement ! Attention ! Risques d'ÉLECTROCUTION, ORGANES MOBILES et PARTIES CHAUDES. Consulter les symboles et les instructions afférentes ci-dessous concernant les mesures à prendre pour supprimer les dangers.

▲ **Indique un message de sécurité particulier**

☞ Signifie NOTE ; n'est pas relatif à la sécurité.

2-2. Dangers relatifs au soudage à l'arc

▲ **Les symboles représentés ci-dessous sont utilisés dans ce manuel pour attirer l'attention et identifier les dangers possibles. En présence de l'un de ces symboles, prendre garde et suivre les instructions afférentes pour éviter tout risque. Les instructions en matière de sécurité indiquées ci-dessous ne constituent qu'un sommaire des instructions de sécurité plus complètes fournies dans les normes de sécurité énumérées dans la Section 2-5. Lire et observer toutes les normes de sécurité.**

▲ **Seul un personnel qualifié est autorisé à installer, faire fonctionner, entretenir et réparer cet appareil.**

▲ **Pendant le fonctionnement, maintenir à distance toutes les personnes, notamment les enfants de l'appareil.**



UNE DÉCHARGE ÉLECTRIQUE peut entraîner la mort.

Le contact d'organes électriques sous tension peut provoquer des accidents mortels ou des brûlures graves. Le circuit de l'électrode et de la pièce est sous tension lorsque le courant est délivré à la sortie. Le circuit d'alimentation et les circuits internes de la machine sont également sous tension lorsque l'alimentation est sur Marche. Dans le mode de soudage avec du fil, le fil, le dérouleur, le bloc de commande du rouleau et toutes les parties métalliques en contact avec le fil sont sous tension électrique. Un équipement installé ou mis à la terre de manière incorrecte ou impropre constitue un danger.

- Ne pas toucher aux pièces électriques sous tension.
- Porter des gants isolants et des vêtements de protection secs et sans trous.
- S'isoler de la pièce à couper et du sol en utilisant des housses ou des tapis assez grands afin d'éviter tout contact physique avec la pièce à couper ou le sol.
- Ne pas se servir de source électrique à courant électrique dans les zones humides, dans les endroits confinés ou là où on risque de tomber.
- Se servir d'une source électrique à courant électrique UNIQUEMENT si le procédé de soudage le demande.
- Si l'utilisation d'une source électrique à courant électrique s'avère nécessaire, se servir de la fonction de télécommande si l'appareil en est équipé.
- D'autres consignes de sécurité sont nécessaires dans les conditions suivantes : risques électriques dans un environnement humide ou si l'on porte des vêtements mouillés ; sur des structures métalliques telles que sols, grilles ou échafaudages ; en position coincée comme assise, à genoux ou couchée ; ou s'il y a un risque élevé de contact inévitable ou accidentel avec la pièce à souder ou le sol. Dans ces conditions, utiliser les équipements suivants, dans l'ordre indiqué : 1) un poste à souder DC à tension constante (à fil), 2) un poste à souder DC manuel (électrode) ou 3) un poste à souder AC à tension à vide réduite. Dans la plupart des situations, l'utilisation d'un poste à souder DC à fil à tension constante est recommandée. En outre, ne pas travailler seul !
- Couper l'alimentation ou arrêter le moteur avant de procéder à l'installation, à la réparation ou à l'entretien de l'appareil. Déverrouiller l'alimentation selon la norme OSHA 29 CFR 1910.147 (voir normes de sécurité).
- Installer le poste correctement et le mettre à la terre convenablement selon les consignes du manuel de l'opérateur et les normes nationales, provinciales et locales.
- Toujours vérifier la terre du cordon d'alimentation. Vérifier et s'assurer que le fil de terre du cordon d'alimentation est bien raccordé à la borne de terre du sectionneur ou que la fiche du cordon est raccordée à une prise correctement mise à la terre.
- En effectuant les raccordements d'entrée, fixer d'abord le conducteur de mise à la terre approprié et contre-vérifier les connexions.

- Vérifier fréquemment le cordon d'alimentation afin de s'assurer qu'il n'est pas altéré ou à nu, le remplacer immédiatement s'il l'est. Un fil à nu peut entraîner la mort.
- L'équipement doit être hors tension lorsqu'il n'est pas utilisé.
- Ne pas utiliser des câbles usés, endommagés, de grosseur insuffisante ou mal épissés.
- Ne pas enrouler les câbles autour du corps.
- Si la pièce soudée doit être mise à la terre, le faire directement avec un câble distinct.
- Ne pas toucher l'électrode quand on est en contact avec la pièce, la terre ou une électrode provenant d'une autre machine.
- Ne pas toucher des porte électrodes connectés à deux machines en même temps à cause de la présence d'une tension à vide doublée.
- N'utiliser qu'un matériel en bon état. Réparer ou remplacer sur-le-champ les pièces endommagées. Entretien l'appareil conformément à ce manuel.
- Porter un harnais de sécurité si l'on doit travailler au-dessus du sol.
- S'assurer que tous les panneaux et couvercles sont correctement en place.
- Fixer le câble de retour de façon à obtenir un bon contact métal-métal avec la pièce à souder ou la table de travail, le plus près possible de la soudure.
- Isoler la pince de masse quand pas mis à la pièce pour éviter le contact avec tout objet métallique.
- Ne pas raccorder plus d'une électrode ou plus d'un câble de masse à une même borne de sortie de soudage.

Il reste une TENSION DC NON NÉGLIGEABLE dans les sources de soudage onduleur quand on a coupé l'alimentation.

- Arrêter les convertisseurs, débrancher le courant électrique et décharger les condensateurs d'alimentation selon les instructions indiquées dans la partie Entretien avant de toucher les pièces.



LES FUMÉES ET LES GAZ peuvent être dangereux.

Le soudage génère des fumées et des gaz. Leur inhalation peut être dangereuse pour la santé.

- Ne pas mettre sa tête au-dessus des vapeurs. Ne pas respirer ces vapeurs.
- À l'intérieur, ventiler la zone et/ou utiliser une ventilation forcée au niveau de l'arc pour l'évacuation des fumées et des gaz de soudage.
- Si la ventilation est médiocre, porter un respirateur anti-vapeurs approuvé.
- Lire et comprendre les spécifications de sécurité des matériaux (MSDS) et les instructions du fabricant concernant les métaux, les consommables, les revêtements, les nettoyeurs et les dégraisseurs.
- Travailler dans un espace fermé seulement s'il est bien ventilé ou en portant un respirateur à alimentation d'air. Demander toujours à un surveillant dûment formé de se tenir à proximité. Des fumées et des gaz de soudage peuvent déplacer l'air et abaisser le niveau d'oxygène provoquant des blessures ou des accidents mortels. S'assurer que l'air de respiration ne présente aucun danger.
- Ne pas souder dans des endroits situés à proximité d'opérations de dégraissage, de nettoyage ou de pulvérisation. La chaleur et les rayons de l'arc peuvent réagir en présence de vapeurs et former des gaz hautement toxiques et irritants.
- Ne pas souder des métaux munis d'un revêtement, tels que l'acier galvanisé, plaqué en plomb ou au cadmium à moins que le revêtement n'ait été enlevé dans la zone de soudure, que l'endroit soit bien ventilé et en portant un respirateur à alimentation d'air. Les revêtements et tous les métaux renfermant ces éléments peuvent dégager des fumées toxiques en cas de soudage.



LES RAYONS D'ARC peuvent entraîner des brûlures aux yeux et à la peau.

Le rayonnement de l'arc du procédé de soudage génère des rayons visibles et invisibles intenses (ultraviolets et infrarouges) susceptibles de provoquer des brûlures dans les yeux et sur la peau.

Des étincelles sont projetées pendant le soudage.

- Porter un casque de soudage approuvé muni de verres filtrants appropriés pour protéger visage et yeux pendant le soudage (voir ANSI Z49.1 et Z87.1 énuméré dans les normes de sécurité).
- Porter des lunettes de sécurité avec écrans latéraux même sous votre casque.
- Avoir recours à des écrans protecteurs ou à des rideaux pour protéger les autres contre les rayonnements les éblouissements et les étincelles ; prévenir toute personne sur les lieux de ne pas regarder l'arc.
- Porter des vêtements confectionnés avec des matières résistantes et ignifuges (cuir, coton lourd ou laine) et des bottes de protection.



LE SOUDAGE peut provoquer un incendie ou une explosion.

Le soudage effectué sur des conteneurs fermés tels que des réservoirs, tambours ou des conduites peut provoquer leur éclatement. Des étincelles peuvent être projetées de l'arc de soudure. La projection d'étincelles, des pièces chaudes et des équipements chauds peuvent provoquer des incendies et des brûlures. Le contact accidentel de l'électrode avec des objets métalliques peut provoquer des étincelles, une explosion, une surchauffe ou un incendie. Avant de commencer le soudage, vérifier et s'assurer que l'endroit ne présente pas de danger.

- Déplacer toutes les substances inflammables à une distance de 10,7 m de l'arc de soudage. En cas d'impossibilité, les recouvrir soigneusement avec des protections homologuées.
- Ne pas souder dans un endroit où des étincelles peuvent tomber sur des substances inflammables.
- Se protéger, ainsi que toute autre personne travaillant sur les lieux, contre les étincelles et le métal chaud.
- Des étincelles et des matériaux chauds du soudage peuvent facilement passer dans d'autres zones en traversant de petites fissures et des ouvertures.
- Afin d'éliminer tout risque de feu, être vigilant et garder toujours un extincteur à la portée de main.
- Le soudage effectué sur un plafond, plancher, paroi ou séparation peut déclencher un incendie de l'autre côté.
- Ne pas effectuer le soudage sur des conteneurs fermés tels que des réservoirs, tambours, ou conduites, à moins qu'ils n'aient été préparés correctement conformément à AWS F4.1 (voir les normes de sécurité).
- Brancher le câble de masse sur la pièce la plus près possible de la zone de soudage pour éviter le transport du courant sur une longue distance par des chemins inconnus éventuels en provoquant des risques d'électrocution, d'étincelles et d'incendie.
- Ne pas utiliser le poste de soudage pour décongeler des conduites gelées.
- En cas de non-utilisation, enlever la baguette d'électrode du porte-électrode ou couper le fil à la pointe de contact.
- Porter des vêtements de protection exempts d'huile tels que des gants en cuir, une veste résistante, des pantalons sans revers, des bottes et un casque.
- Avant de souder, retirer toute substance combustible de ses poches telles qu'un allumeur au butane ou des allumettes.
- Suivre les consignes de OSHA 1910.252 (a) (2) (iv) et de NFPA 51B pour travaux de soudage et prévoir un détecteur d'incendie et un extincteur à proximité.

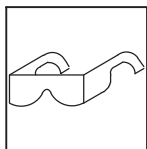

DES PARTICULES VOLANTES peuvent blesser les yeux.

- Le soudage, l'écaillage, le passage de la pièce à la brosse en fil de fer, et le meulage génèrent des étincelles et des particules métalliques volantes. Pendant la période de refroidissement des soudures, elles risquent de projeter du laitier.
- Porter des lunettes de sécurité avec écrans latéraux ou un écran facial.



LES ACCUMULATIONS DE GAZ risquent de provoquer des blessures ou même la mort.

- Fermer l'alimentation du gaz protecteur en cas de non-utilisation.
- Veiller toujours à bien aérer les espaces confinés ou se servir d'un respirateur d'adduction d'air homologué.



DES PIÈCES CHAUDES peuvent provoquer des brûlures graves.

- Ne pas toucher des parties chaudes à mains nues.
- Prévoir une période de refroidissement avant d'utiliser le pistolet ou la torche.
- Ne pas toucher aux pièces chaudes, utiliser les outils recommandés et porter des gants de soudage et des vêtements épais pour éviter les brûlures.



LES CHAMPS MAGNÉTIQUES peuvent affecter les stimulateurs cardiaques.

- Porteurs de stimulateur cardiaque, rester à distance.
- Les porteurs d'un stimulateur cardiaque doivent d'abord consulter leur médecin avant de s'approcher des opérations de soudage à l'arc, de gougeage ou de soudage par points.



LE BRUIT peut endommager l'ouïe.

Le bruit des processus et des équipements peut affecter l'ouïe.

- Porter des protections approuvées pour les oreilles si le niveau sonore est trop élevé.



LES BOUTEILLES peuvent exploser si elles sont endommagées.

Des bouteilles de gaz protecteur contiennent du gaz sous haute pression. Si une bouteille est endommagée, elle peut exploser. Du fait que les bouteilles de gaz font normalement partie du procédé de soudage, les manipuler avec précaution.

- Protéger les bouteilles de gaz comprimé d'une chaleur excessive, des chocs mécaniques, des dommages physiques, du laitier, des flammes ouvertes, des étincelles et des arcs.
- Placer les bouteilles debout en les fixant dans un support stationnaire ou dans un porte-bouteilles pour les empêcher de tomber ou de se renverser.
- Tenir les bouteilles éloignées des circuits de soudage ou autres circuits électriques.
- Ne jamais placer une torche de soudage sur une bouteille à gaz.
- Une électrode de soudage ne doit jamais entrer en contact avec une bouteille.
- Ne jamais souder une bouteille pressurisée – risque d'explosion.
- Utiliser seulement des bouteilles de gaz protecteur, régulateurs, tuyaux et raccords convenables pour cette application spécifique ; les maintenir ainsi que les éléments associés en bon état.
- Détourner votre visage du détendeur-régulateur lorsque vous ouvrez la soupape de la bouteille.
- Le couvercle du détendeur doit toujours être en place, sauf lorsque la bouteille est utilisée ou qu'elle est reliée pour usage ultérieur.
- Utiliser les équipements corrects, les bonnes procédures et suffisamment de personnes pour soulever et déplacer les bouteilles.
- Lire et suivre les instructions sur les bouteilles de gaz comprimé, l'équipement connexe et le dépliant P-1 de la CGA (Compressed Gas Association) mentionné dans les principales normes de sécurité.

2-3. Dangers supplémentaires en relation avec l'installation, le fonctionnement et la maintenance



Risque D'INCENDIE OU D'EXPLOSION.

- Ne pas placer l'appareil sur, au-dessus ou à proximité de surfaces inflammables.
- Ne pas installer l'appareil à proximité de produits inflammables.
- Ne pas surcharger l'installation électrique – s'assurer que l'alimentation est correctement dimensionnée et protégée avant de mettre l'appareil en service.



LA CHUTE DE L'APPAREIL peut blesser.

- Utiliser l'anneau de levage uniquement pour soulever l'appareil, NON PAS les chariots, les bouteilles de gaz ou tout autre accessoire.
- Utiliser un équipement de levage de capacité suffisante pour lever l'appareil.
- En utilisant des fourches de levage pour déplacer l'unité, s'assurer que les fourches sont suffisamment longues pour dépasser du côté opposé de l'appareil.

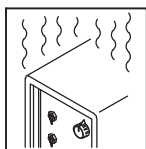

L'EMPLOI EXCESSIF peut SURCHAUFFER L'ÉQUIPEMENT.

- Prévoir une période de refroidissement ; respecter le cycle opératoire nominal.
- Réduire le courant ou le facteur de marche avant de poursuivre le soudage.
- Ne pas obstruer les passages d'air du poste.

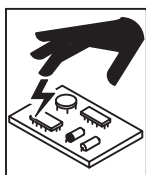

LES CHARGES ÉLECTROSTATIQUES peuvent endommager les circuits imprimés.

- Établir la connexion avec la barrette de terre avant de manipuler des cartes ou des pièces.
- Utiliser des pochettes et des boîtes antistatiques pour stocker, déplacer ou expédier des cartes PC.



DES ORGANES MOBILES peuvent provoquer des blessures.

- Ne pas s'approcher des organes mobiles.
- Ne pas s'approcher des points de coincement tels que des rouleaux de commande.



LES FILS DE SOUDAGE peuvent provoquer des blessures.

- Ne pas appuyer sur la gâchette avant d'en avoir reçu l'instruction.
- Ne pas diriger le pistolet vers soi, d'autres personnes ou toute pièce mécanique en engageant le fil de soudage.



DES ORGANES MOBILES peuvent provoquer des blessures.

- S'abstenir de toucher des organes mobiles tels que des ventilateurs.
- Maintenir fermés et verrouillés les portes, panneaux, recouvrements et dispositifs de protection.
- Seules des personnes qualifiées sont autorisées à enlever les portes, panneaux, recouvrements ou dispositifs de protection pour l'entretien.
- Remettre les portes, panneaux, recouvrements ou dispositifs de protection quand l'entretien est terminé et avant de rebrancher l'alimentation électrique.

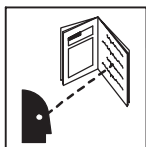

LIRE LES INSTRUCTIONS.

- Lire le manuel d'utilisation avant d'utiliser ou d'intervenir sur l'appareil.
- Utiliser uniquement des pièces de rechange Miller/Hobart.

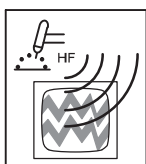

LE RAYONNEMENT HAUTE FRÉQUENCE (HF) risque de provoquer des interférences.

- Le rayonnement haute fréquence (HF) peut provoquer des interférences avec les équipements de radio-navigation et de communication, les services de sécurité et les ordinateurs.
- Demander seulement à des personnes qualifiées familiarisées avec des équipements électroniques de faire fonctionner l'installation.
- L'utilisateur est tenu de faire corriger rapidement par un électricien qualifié les interférences résultant de l'installation.
- Si le FCC signale des interférences, arrêter immédiatement l'appareil.
- Effectuer régulièrement le contrôle et l'entretien de l'installation.
- Maintenir soigneusement fermés les portes et les panneaux des sources de haute fréquence, maintenir les éclateurs à une distance correcte et utiliser une terre et un blindage pour réduire les interférences éventuelles.

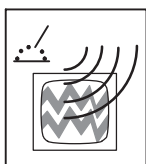

LE SOUDAGE À L'ARC risque de provoquer des interférences.

- L'énergie électromagnétique peut gêner le fonctionnement d'appareils électroniques comme des ordinateurs et des robots.
- Veiller à ce que tout l'équipement de la zone de soudage soit compatible électromagnétiquement.
- Pour réduire la possibilité d'interférence, maintenir les câbles de soudage aussi courts que possible, les grouper, et les poser aussi bas que possible (ex. par terre).
- Veiller à souder à une distance de 100 mètres de tout équipement électronique sensible.
- Veiller à ce que ce poste de soudage soit posé et mis à la terre conformément à ce mode d'emploi.
- En cas d'interférences après avoir pris les mesures précédentes, il incombe à l'utilisateur de prendre des mesures supplémentaires telles que le déplacement du poste, l'utilisation de câbles blindés, l'utilisation de filtres de ligne ou la pose de protecteurs dans la zone de travail.

2-4. Proposition californienne 65 Avertissements

▲ Les équipements de soudage et de coupage produisent des fumées et des gaz qui contiennent des produits chimiques dont l'État de Californie reconnaît qu'ils provoquent des malformations congénitales et, dans certains cas, des cancers. (Code de santé et de sécurité de Californie, chapitre 25249.5 et suivants)

▲ Les batteries, les bornes et autres accessoires contiennent du plomb et des composés à base de plomb, produits chimiques dont l'État de Californie reconnaît qu'ils provoquent des cancers et des malformations congénitales ou autres problèmes de procréation. Se laver les mains après manipulation.

Pour les moteurs à essence :

▲ Les gaz d'échappement des moteurs contiennent des produits chimiques dont l'État de Californie reconnaît qu'ils provoquent des cancers et des malformations congénitales ou autres problèmes de procréation.

Pour les moteurs diesel :

▲ Les gaz d'échappement des moteurs diesel et certains de leurs composants sont reconnus par l'État de Californie comme provoquant des cancers et des malformations congénitales ou autres problèmes de procréation.

2-5. Principales normes de sécurité

Safety in Welding, Cutting, and Allied Processes, ANSI Standard Z49.1, de Global Engineering Documents (téléphone : 1-877-413-5184, site Internet : www.global.ihs.com).

Recommended Safe Practices for the Preparation for Welding and Cutting of Containers and Piping, American Welding Society Standard AWS F4.1 de Global Engineering Documents (téléphone : 1-877-413-5184, site Internet : www.global.ihs.com).

National Electrical Code, NFPA Standard 70, de National Fire Protection Association, P.O. Box 9101, 1 Battery March Park, Quincy, MA 02269-9101 (téléphone : 617-770-3000, site Internet : www.nfpa.org).

Safe Handling of Compressed Gases in Cylinders, CGA Pamphlet P-1, de Compressed Gas Association, 1735 Jefferson Davis Highway, Suite 1004, Arlington, VA 22202-4102 (téléphone : 703-412-0900, site Internet : www.cganet.com).

Code for Safety in Welding and Cutting, CSA Standard W117.2, de Canadian Standards Association, Standards Sales, 178 Rexdale

Boulevard, Rexdale, Ontario, Canada M9W 1R3 (téléphone : 800-463-6727 ou à Toronto 416-747-4044, site Internet : www.csa-international.org).

Practice For Occupational And Educational Eye And Face Protection, ANSI Standard Z87.1, de American National Standards Institute, 11 West 42nd Street, New York, NY 10036-8002 (téléphone : 212-642-4900, site Internet : www.ansi.org).

Standard for Fire Prevention During Welding, Cutting, and Other Hot Work, NFPA Standard 51B, de National Fire Protection Association, P.O. Box 9101, 1 Battery March Park, Quincy, MA 02269-9101 (téléphone : 617-770-3000, site Internet : www.nfpa.org).

OSHA, Occupational Safety and Health Standards for General Industry, Title 29, Code of Federal Regulations (CFR), Part 1910, Subpart Q, and Part 1926, Subpart J, de U.S. Government Printing Office, Superintendent of Documents, P.O. Box 371954, Pittsburgh, PA 15250 (il y a 10 bureaux régionaux--le téléphone de la région 5, Chicago, est 312-353-2220, site Internet : www.osha.gov).

2-6. Information EMF

Considérations sur le soudage et les effets de basse fréquence et des champs magnétiques et électriques.

Le courant de soudage, pendant son passage dans les câbles de soudage, causera des champs électromagnétiques. Il y a eu et il y a encore un certain souci à propos de tels champs. Cependant, après avoir examiné plus de 500 études qui ont été faites pendant une période de recherche de 17 ans, un comité spécial ruban bleu du National Research Council a conclu : « L'accumulation de preuves, suivant le jugement du comité, n'a pas démontré que l'exposition aux champs magnétiques et champs électriques à haute fréquence représente un risque à la santé humaine ». Toutefois, des études sont toujours en cours et les preuves continuent à être examinées. En attendant que les conclusions finales de la recherche soient établies, il vous serait souhaitable de réduire votre exposition aux champs électromagnétiques pendant le soudage ou le coupage.

Pour réduire les champs magnétiques sur le poste de travail, appliquer les procédures suivantes :

1. Maintenir les câbles ensemble en les tordant ou en les enveloppant.
2. Disposer les câbles d'un côté et à distance de l'opérateur.
3. Ne pas courber pas et ne pas entourer pas les câbles autour de votre corps.
4. Garder le poste de soudage et les câbles le plus loin possible de vous.
5. Connecter la pince sur la pièce aussi près que possible de la soudeuse.

En ce qui concerne les stimulateurs cardiaques

Les porteurs de stimulateur cardiaque doivent consulter leur médecin avant de souder ou d'approcher des opérations de soudage. Si le médecin approuve, il est recommandé de suivre les procédures précédentes.

SECTION 3 – SPECIFICATIONS

3-1. Specifications

A. 115 VAC Model

Rated Welding Output	Amperage Range		Maximum Open-Circuit Voltage DC	Amperes Input at Rated Load Output 115 V, 60 Hz, Single-Phase	KVA	KW	Weight W/ Gun	Overall Dimensions
90 A @ 18 Volts DC, 20% Duty Cycle 63 A @ 21 Volts DC, 20% Duty Cycle*	30 – 140		28	20 15*	2.8 2.1*	2.4 1.8*	60 lb (27 kg)	Length: 17-1/2 in (444 mm) Width: 10-5/8 in (273 mm) Height: 15-3/4 in (400 mm)
Wire Type And Dia	Solid	Stainless	Flux Cored	Wire Feed Speed Range w/Wire Feed Speed Tracking On				
	.024 - .030 in (0.6 - 0.8 mm)	.023 - .030 in (0.6 - 0.8 mm)	.030 - .035 in (0.8 - 0.9 mm)	45 – 500 IPM (1.1 – 12.7 m/min) At No Load 40 – 500 IPM (1.0 – 12.7 m/min) Feeding Wire				
* CSA Rating								

B. 115 VAC Model w/Auto-Set™

Rated Welding Output	Amperage Range		Maximum Open-Circuit Voltage DC	Amperes Input at Rated Load Output 115 V, 60 Hz, Single-Phase	KVA	KW	Weight W/ Gun	Overall Dimensions
90 A @ 18 Volts DC, 20% Duty Cycle 63 A @ 21 Volts DC, 20% Duty Cycle*	30 – 140		28	20 15*	2.8 2.1*	2.4 1.8*	60 lb (27 kg)	Length: 17-1/2 in (444 mm) Width: 10-5/8 in (273 mm) Height: 15-3/4 in (400 mm)
Wire Type And Dia	Solid	Stainless	Flux Cored	Wire Feed Speed Range				
	.024 - .030 in (0.6 - 0.8 mm)	.023 - .030 in (0.6 - 0.8 mm)	.030 - .035 in (0.8 - 0.9 mm)	35 – 420 IPM (0.9 – 10.7 m/min) At No Load 15 – 390 IPM (0.4 – 9.9 m/min) Feeding Wire				
* CSA Rating								

C. 230 VAC Model

Rated Welding Output	Amperage Range	Maximum Open-Circuit Voltage DC	Amperes Input at Rated Load Output 230 V, 60 Hz, Single-Phase	KVA	KW	Weight W/ Gun	Overall Dimensions
135 A @ 22.5 Volts DC, 30% Duty Cycle At 60 Hz Input	30 – 180	31	21.7	5.0	4.1	72 lb (32.7 kg)	Length: 17-1/2 in (444 mm) Width: 10-5/8 in (273 mm) Height: 15-3/4 in (400 mm)
Wire Type And Dia	Solid/ Stainless	Flux Cored	Wire Feed Speed Range w/Wire Feed Speed Tracking On				
	.024 – .035 in (0.6 – 0.9 mm)	.030 – .045 in (0.8 – 1.2 mm)	100 – 725 IPM (2.5 – 18.4 m/min) At No Load 90 – 700 IPM (2.3 – 17.8 m/min) Feeding Wire				

3-2. Duty Cycle And Overheating



A. 115 VAC Model

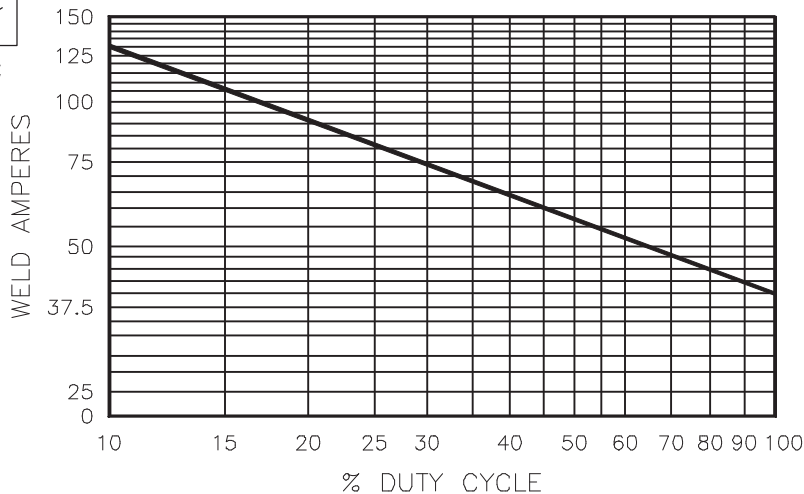

Duty Cycle is percentage of 10 minutes that unit can weld at rated load without overheating.

If unit overheats, thermostat(s) opens, output stops, and cooling fan runs. Wait fifteen minutes for unit to cool. Reduce amperage or duty cycle before welding.

▲ Exceeding duty cycle can damage unit or gun and void warranty.

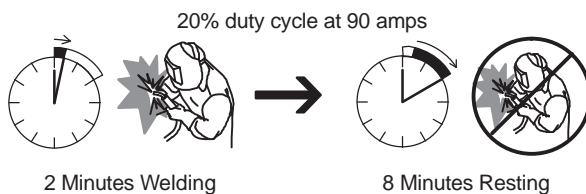

B. 230 VAC Model

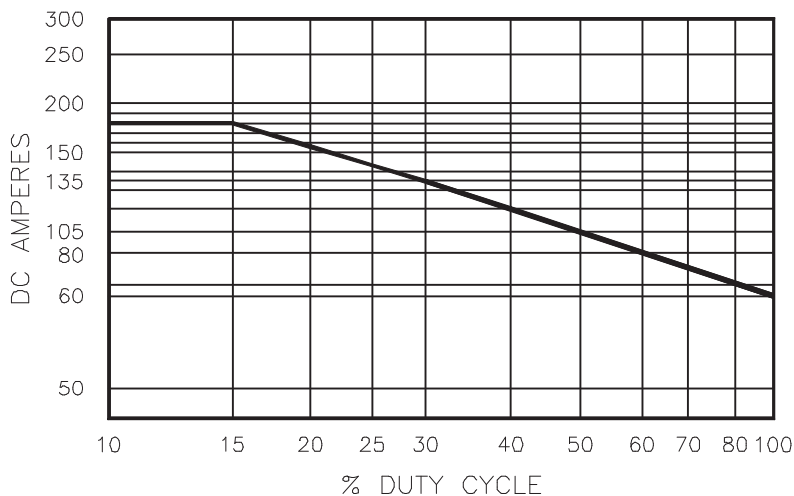

30% duty cycle at 135 amps, 60 Hz

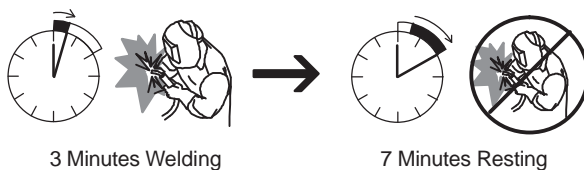

Overheating

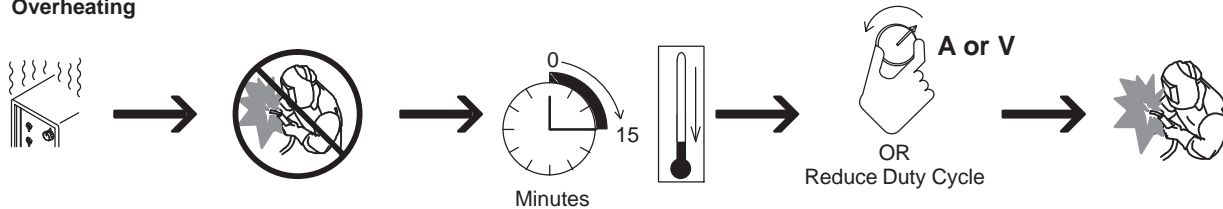

3-3. Volt-Ampere Curves

A. 115 VAC Model

The volt-ampere curves show the minimum and maximum voltage and amperage output capabilities of the welding power source. Curves of other settings fall between the curves shown.

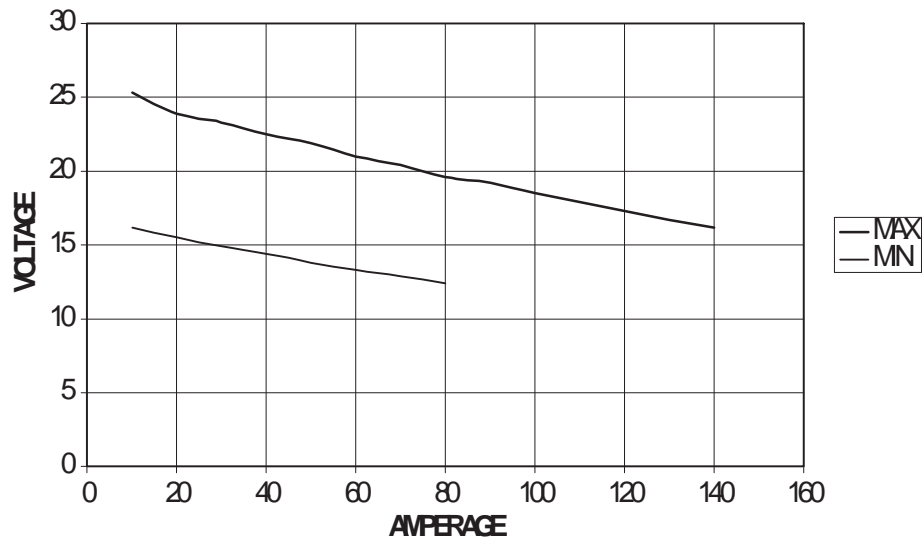

B. 230 VAC Model

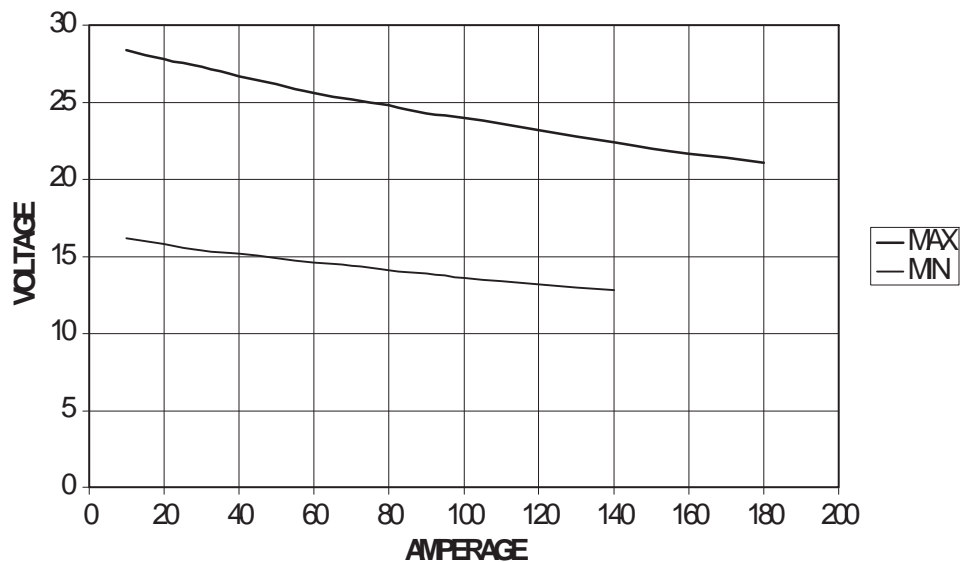

SECTION 4 – INSTALLATION

4-1. Installing Welding Gun

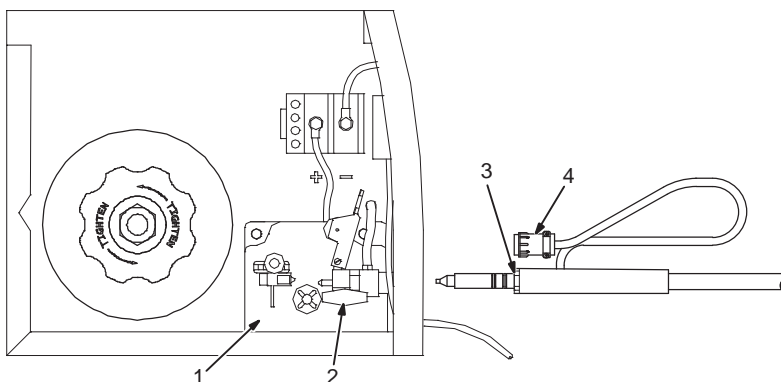

- 1 Drive Assembly
- 2 Gun Securing Knob
- 3 Gun End

Loosen knob. Insert gun end through opening until it bottoms against drive assembly. Tighten knob.

- 4 Gun Trigger Plug
- Insert into receptacle, and tighten threaded collar.

Close door.

Be sure that gun end is tight against drive assembly.

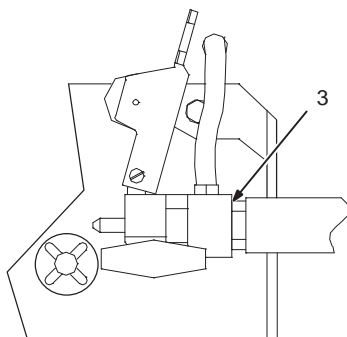

Correct

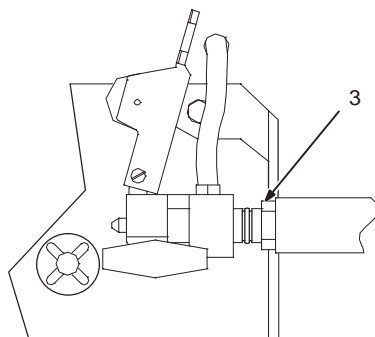

Incorrect

Ref. 802 982-A / Ref. 801 987

4-2. Installing Work Clamp



Connection hardware must be tightened with proper tools. Do not just hand tighten hardware. A loose electrical connection will cause poor weld performance and excessive heating of the work clamp.

- 1 Nut
- 2 Work Cable From Unit
- 3 Work Clamp
- 4 Screw
- 5 Work Clamp Tabs

Bend tabs around work cable.

- 6 Insulating Sleeves

Slide one insulating sleeve over work cable before connecting to clamp.

Slide insulating sleeves over handles.

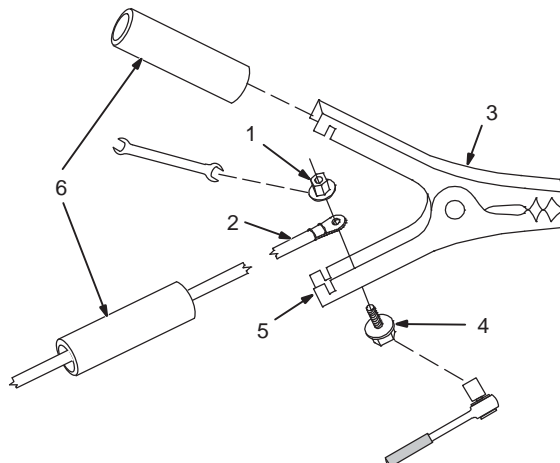

Tools Needed:

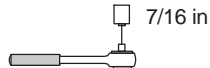

802 456-A

4-3. Work Cable Routing Inside Unit



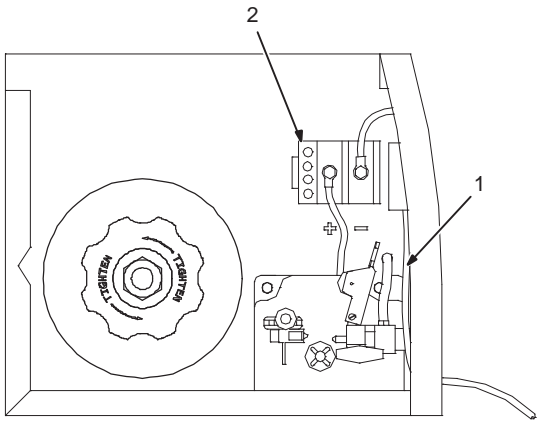

1 Work Cable
2 Output Terminal Block

Insert work cable through opening in front panel and route along back of front panel to output terminal block.

Close door.

Ref. 802 982-A

4-4. Process/Polarity Table

Process	Polarity	Cable Connections	
		Cable To Gun	Cable To Work
GMAW – Solid wire with shielding gas	DCEP – Reverse polarity	Connect to positive (+) output terminal	Connect to negative (-) output terminal
FCAW – Self-shielding wire – no shielding gas	DCEN – Straight Polarity	Connect to negative (-) output terminal	Connect to positive (+) output terminal

4-5. Changing Polarity



Connection hardware must be tightened with proper tools. Do not just hand tighten hardware. A loose electrical connection will cause poor weld performance and excessive heating at the terminal block.

1 Lead Connections For Direct Current Electrode Positive (DCEP)

2 Lead Connections For Direct Current Electrode Negative (DCEN)

Always read and follow wire manufacturer's recommended polarity, and see Section 4-4.

Close door.

CHANGING POLARITY

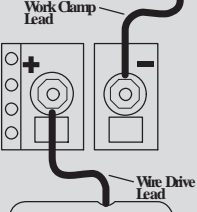
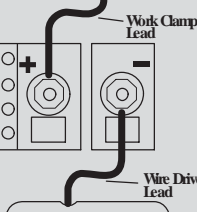
DCEP Electrode Positive FOR SOLID WIRE	DCEN Electrode Negative Flux Core Wire
	

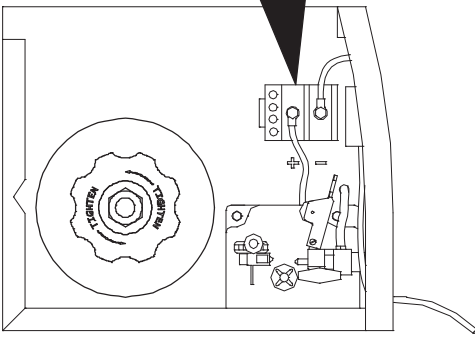

Ref. 203 501 / Ref. 802 982-

4-6. Installing Gas Supply



DO NOT use Argon/Mixed gas regulator/flowmeter with CO₂ shielding gas. See Parts List for optional CO₂ gas regulator/flowmeter and hose.

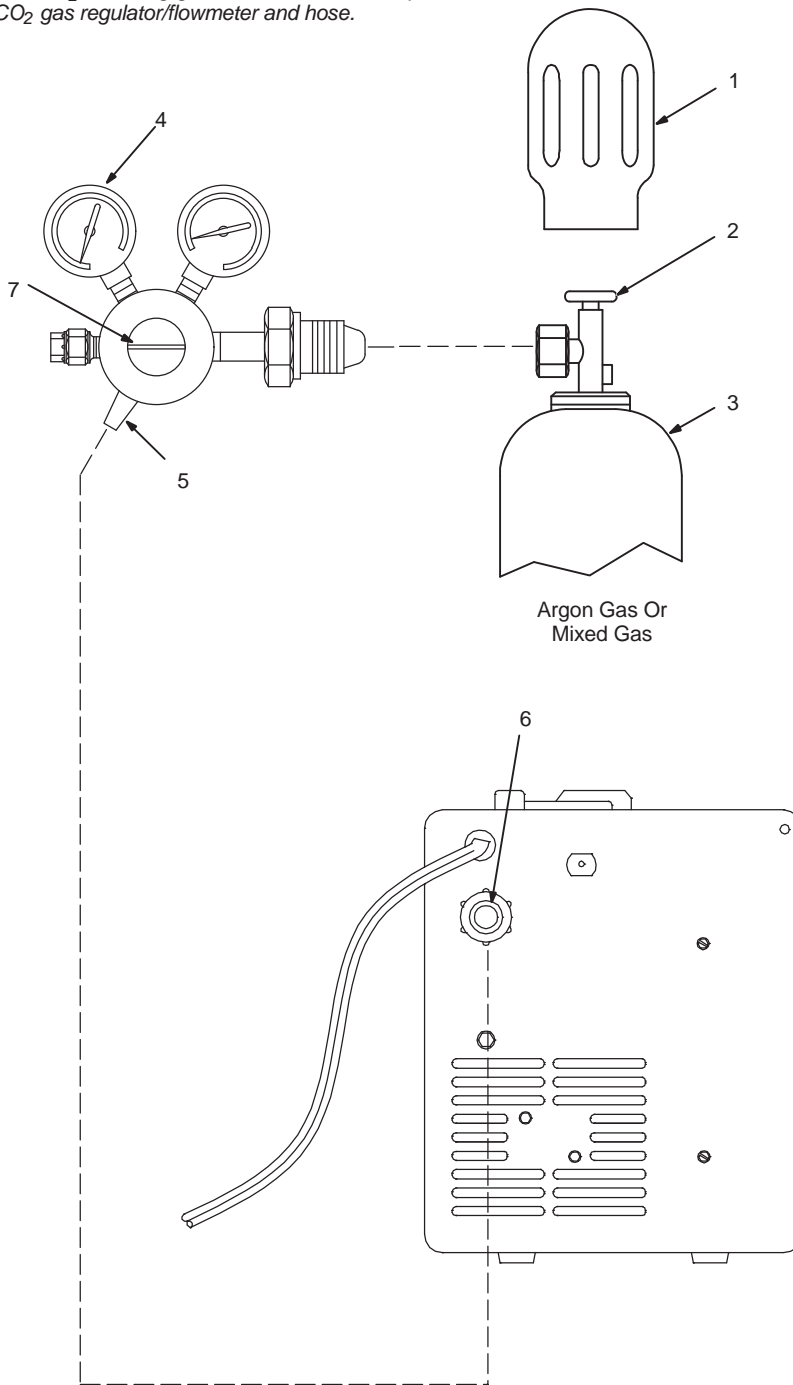

Obtain gas cylinder and chain to running gear, wall, or other stationary support so cylinder cannot fall and break off valve.

- 1 Cap
- 2 Cylinder Valve

Remove cap, stand to side of valve, and open valve slightly. Gas flow blows dust and dirt from valve. Close valve.

- 3 Cylinder
- 4 Regulator/Flowmeter

Install so face is vertical.

- 5 Regulator/Flowmeter Gas Hose Connection
- 6 Welding Power Source Gas Hose Connection

Connect supplied gas hose between regulator/flowmeter gas hose connection, and fitting on rear of welding power source.

- 7 Flow Adjust

Typical flow rate is 20 cfh (cubic feet per hour). Check wire manufacturer's recommended flow rate.

Tools Needed:



4-7. Selecting A Location And Connecting Input Power For 115 VAC Model

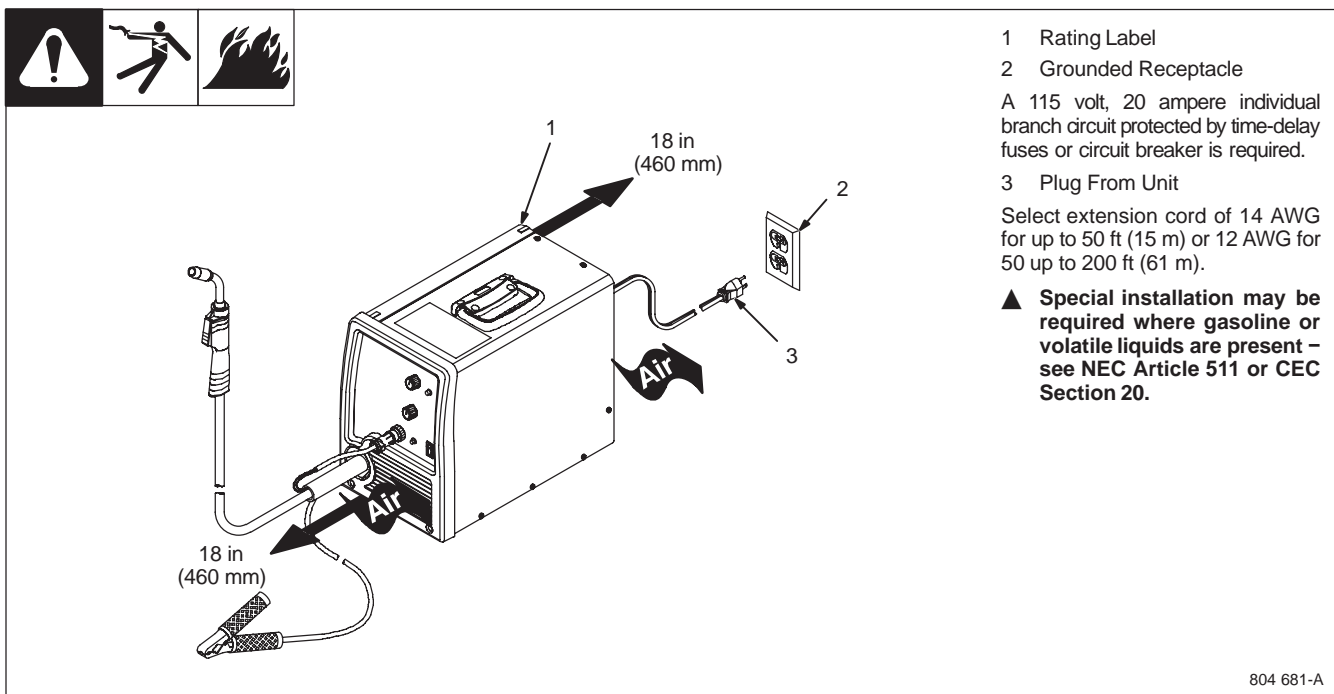

4-8. Selecting A Location And Connecting Input Power For 230 VAC Model



▲ Do not move or operate unit where it could tip.

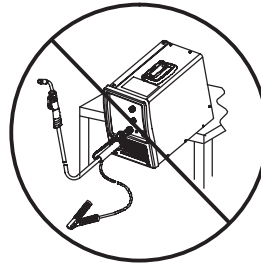

18 in (457 mm) of space for airflow

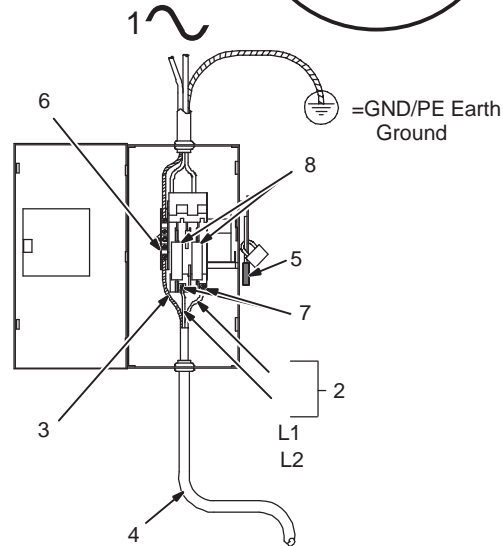
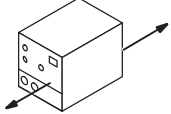

▲ Installation must meet all National and Local Codes – have only qualified persons make this installation.

▲ Disconnect and lockout/tag-out input power before connecting input conductors from unit.

▲ Always connect green or green/yellow conductor to supply grounding terminal first, and never to a line terminal.

1 Rating Label

Supply correct input power.

2 Black And White Input Conductor (L1 And L2)

3 Green Or Green/Yellow Grounding Conductor

4 Input Power Cord.

5 Disconnect Device (switch shown in the OFF position)

6 Disconnect Device Grounding Terminal

7 Disconnect Device Line Terminals

Connect green or green/yellow grounding conductor to disconnect device grounding terminal first.

Connect input conductors L1 and L2 to disconnect device line terminals.

8 Over-Current Protection

Select type and size of over-current protection using Section 4-9 (fused disconnect switch shown).

Close and secure door on disconnect device. Remove lockout/tagout device, and place switch in the On position.

9 Plug (NEMA 6-50P)

10 Receptacle (NEMA 6-50R)

Connect plug to receptacle.

▲ Special installation may be required where gasoline or volatile liquids are present – see NEC Article 511 or CEC Section 20.

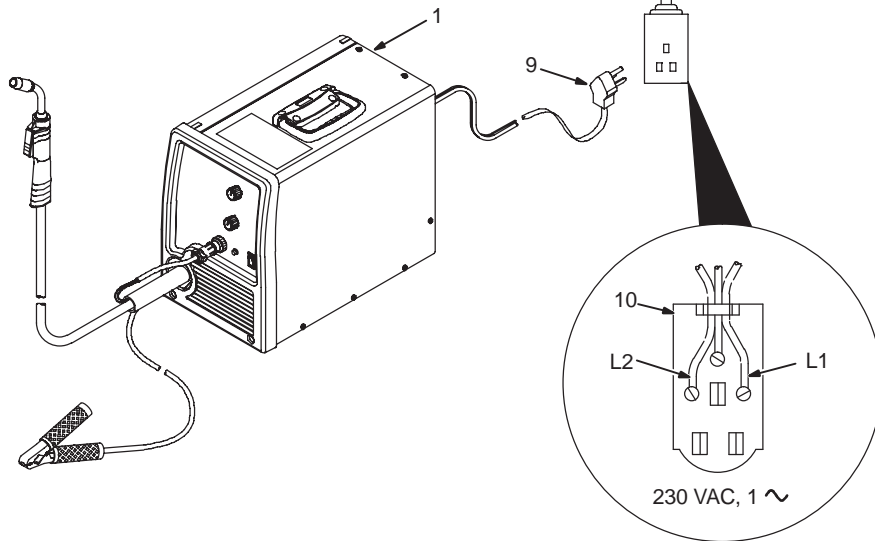

Tools Needed:



4-9. Electrical Service Guide For 230 VAC Model

	60 Hz Single Phase
Input Voltage	230
Input Amperes At Rated Output	21.7
Max Recommended Standard Fuse Rating In Amperes	
Circuit Breaker ¹ , Time-Delay ²	25
Normal Operating ³	30
Min Input Conductor Size In AWG ⁴	14
Max Recommended Input Conductor Length In Feet (Meters)	61 (19)
Min Grounding Conductor Size In AWG ⁴	14

Reference: 2005 National Electrical Code (NEC) (including article 630)

1 Choose a circuit breaker with time-current curves comparable to a Time Delay Fuse.



2 "Time-Delay" fuses are UL class "RK5".

3 "Normal Operating" (general purpose - no intentional delay) fuses are UL class "K5" (up to and including 60 amp), and UL class "H" (65 amp and above).

4 Conductor data in this section specifies conductor size (excluding flexible cord or cable) between the panelboard and the equipment per NEC Table 310.16. If a flexible cord or cable is used, minimum conductor size may increase. See NEC Table 400.5(A) for flexible cord and cable requirements.

▲ Caution: Failure to follow these fuse and circuit breaker recommendations could create an electric shock or fire hazard. These recommendations are for a dedicated branch circuit that applies to the rated output and duty cycle of the welding power source.

4-10. Installing Wire Spool And Adjusting Hub Tension



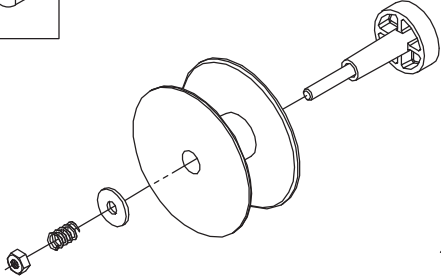

Installing 4 in (102 mm) Wire Spool

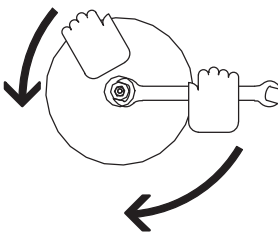



When a slight force is needed to turn spool, tension is set.



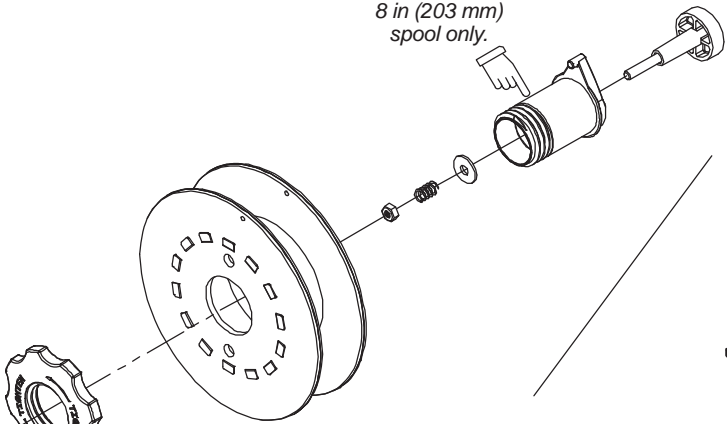

Installing 8 in (203 mm) Wire Spool



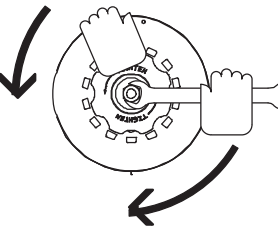

Adapter used with 8 in (203 mm) spool only.

Retaining ring used with 8 in (203 mm) spool only.



When a slight force is needed to turn spool, tension is set.

Tools Needed:

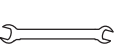

1/2 in

803 012 / 803 013 -B / Ref. 802 444-C

4-11. Threading Welding Wire



- 1 Wire Spool
 - 2 Welding Wire
 - 3 Inlet Wire Guide
 - 4 Pressure Adjustment Knob
 - 5 Drive Roll
 - 6 Gun Conduit Cable
- Lay gun cable out straight.

Tools Needed:

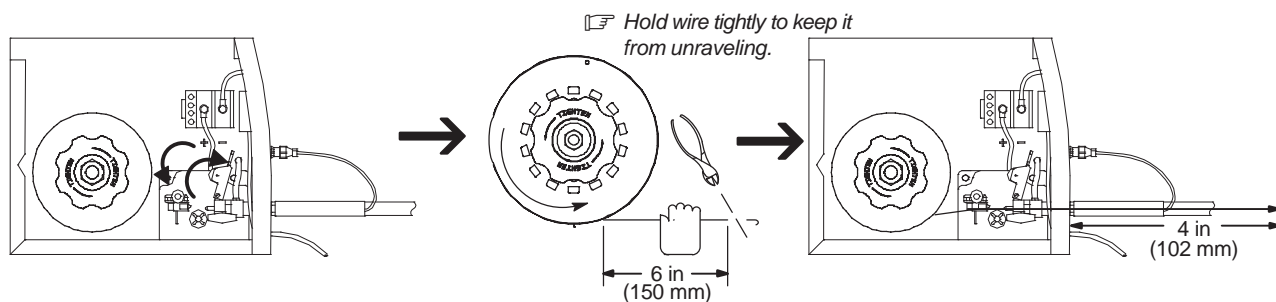
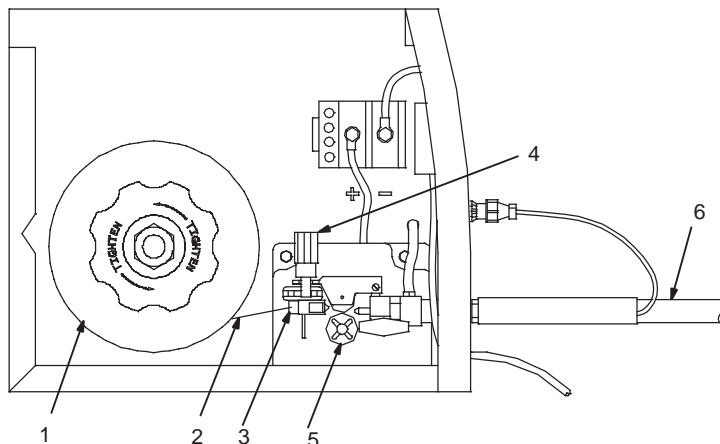

Open pressure assembly.

Pull and hold wire; cut off end.

Push wire thru guides into gun; continue to hold wire.

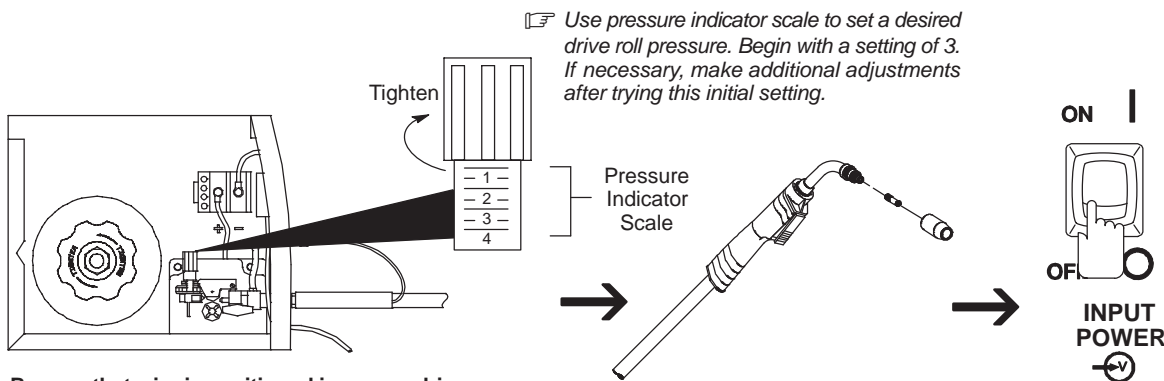

Be sure that wire is positioned in proper drive roll groove and wire is laying in the groove.

Close and tighten pressure assembly, and let go of wire.

Remove gun nozzle and contact tip.

Turn power on.

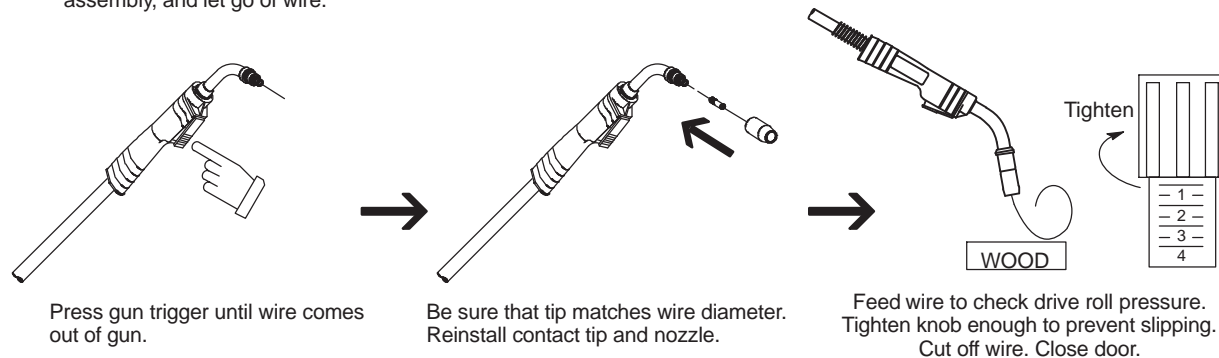

Press gun trigger until wire comes out of gun.

Be sure that tip matches wire diameter. Reinstall contact tip and nozzle.

Feed wire to check drive roll pressure. Tighten knob enough to prevent slipping. Cut off wire. Close door.

4-12. Removing MIG Gun From Welding Power Source

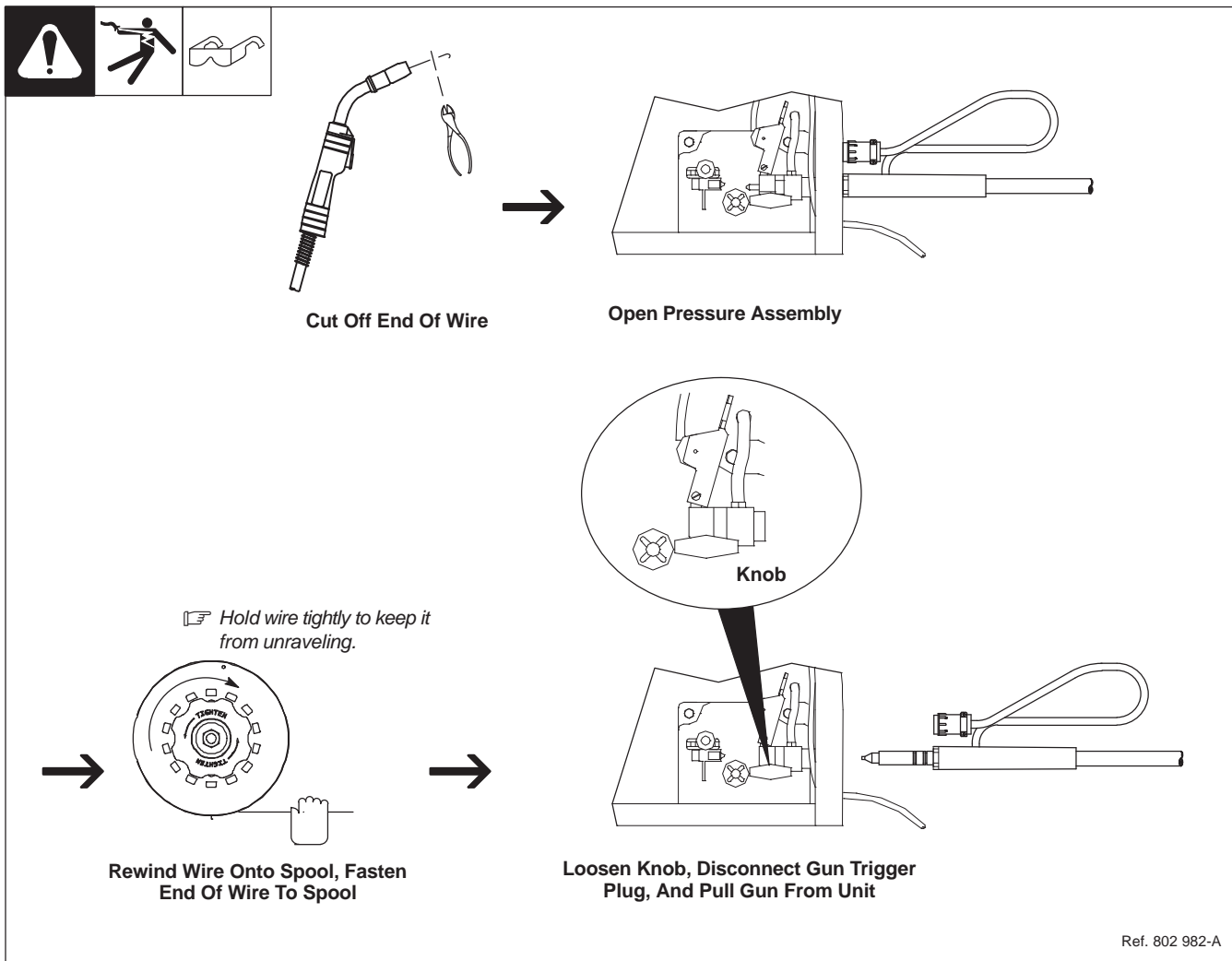

4-13. Installing Optional Spool Gun Switch In Welding Power Source

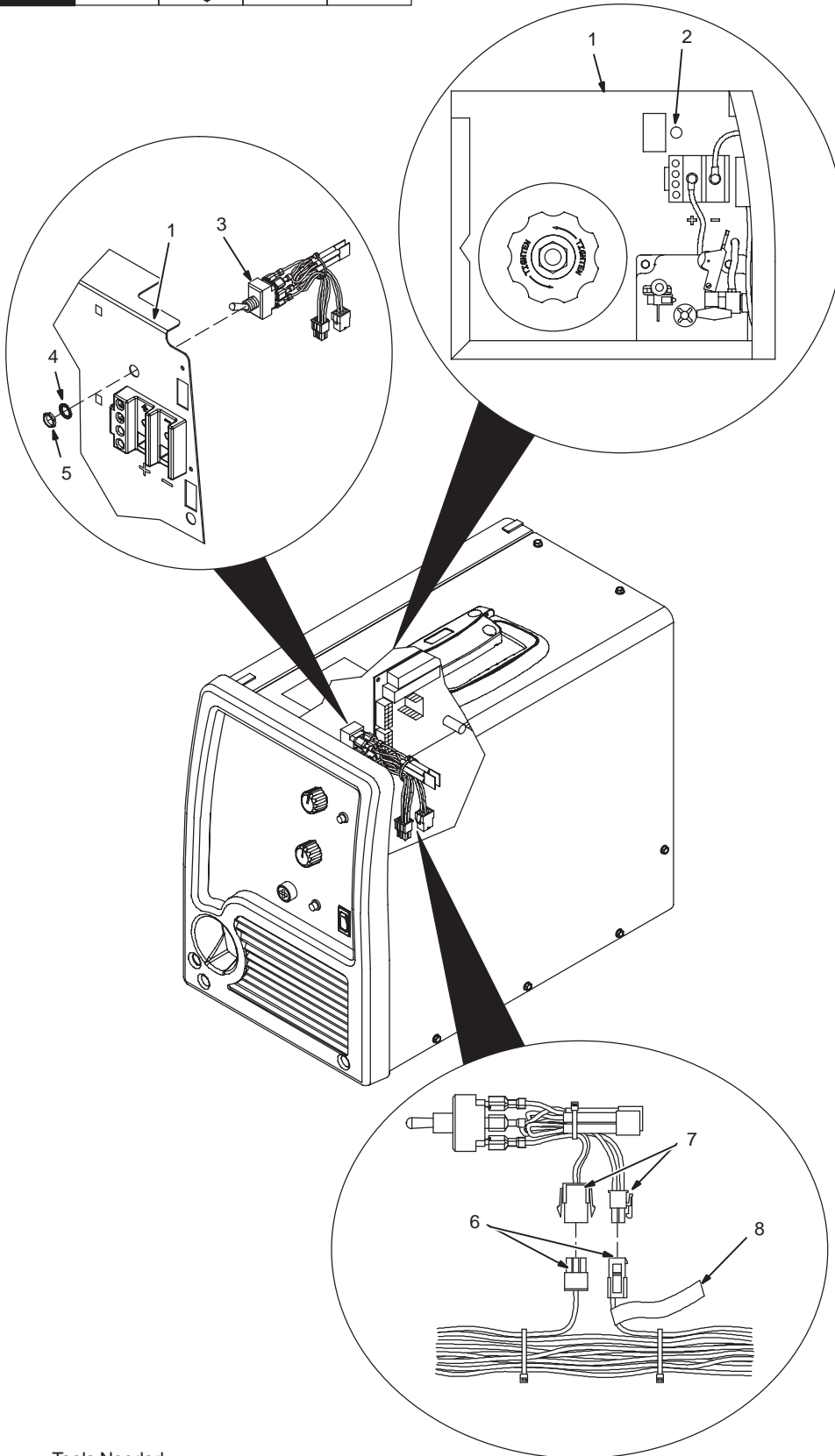

▲ Turn Off unit, and disconnect input power.

☞ For units prior to Serial No. LH210051N, use retrokit part no. 234402 for installing spool gun switch.

Remove wrapper from welding power source.

1 Welding Power Source Center Baffle

2 Snap-in Blank

Remove and discard snap-in blank from hole in center baffle.

3 Switch Assembly

4 Star Washer

5 Jam Nut

Remove top jam nut and star washer from switch (switch is equipped with two nuts, a jam nut and a backing nut).

Insert switch assembly into center baffle so that keyway in switch shaft is facing up.

Secure switch to center baffle with star washer and jam nut. Tighten jam nut enough to keep switch from rotating.

6 Wiring Harness Connectors

7 Switch Connectors

8 Label

Locate and separate connectors in wiring harness near label.

Connect switch connectors to matching connectors in wiring harness.

Install wrapper on unit.

Operation:

Place switch in the position with the spool gun symbol on the label for spool gun operation. Place switch in the position with the MIG gun symbol on the label for wire feeder/MIG (GMAW) gun operation.

When the switch is in the spool gun position, spool gun wire feed speed and voltage are controlled by welding power source controls.

Tools Needed:



4-14. Connecting Spool Gun To Millermatic 140/180

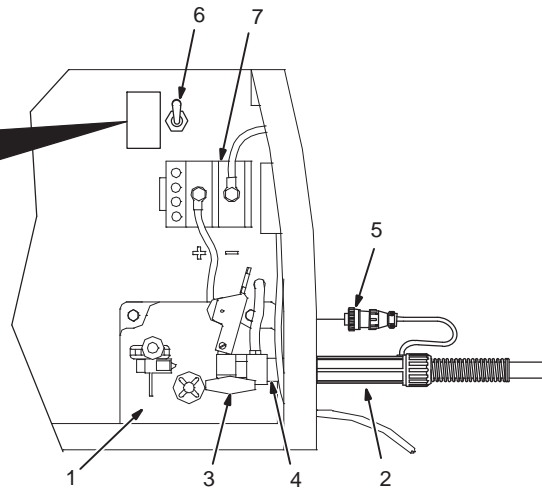
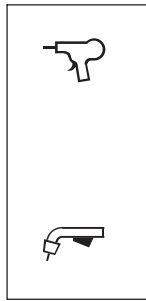

- 1 Drive Assembly
- 2 Spool Gun
- 3 Gun Securing Knob
- 4 Gun End

Loosen thumbscrew. Insert end through opening until it bottoms against drive assembly. Tighten gun securing knob.

Spool gun must be inserted completely to prevent leakage of shielding gas.

- 5 Gun Trigger Plug

Insert plug into receptacle, and tighten threaded collar.

- 6 Spool Gun/MIG Gun Switch

Place switch in Spool Gun position.

- 7 Polarity Changeover Terminal Block

To make proper polarity connection, see welding power source Owner's Manual.

Close door.

Be sure that gun end is tight against drive assembly.

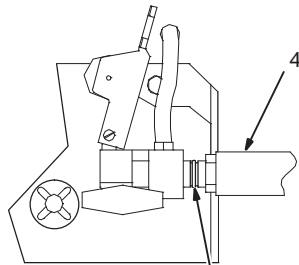

**Incorrect
Gun Not Seated**

Exposed O-rings
will cause shielding
gas leakage.

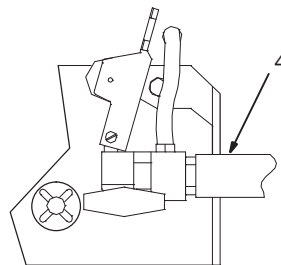

**Correct
Gun Fully Seated**

SECTION 5 – OPERATION

5-1. Controls For 115 VAC Model w/Auto-Set™

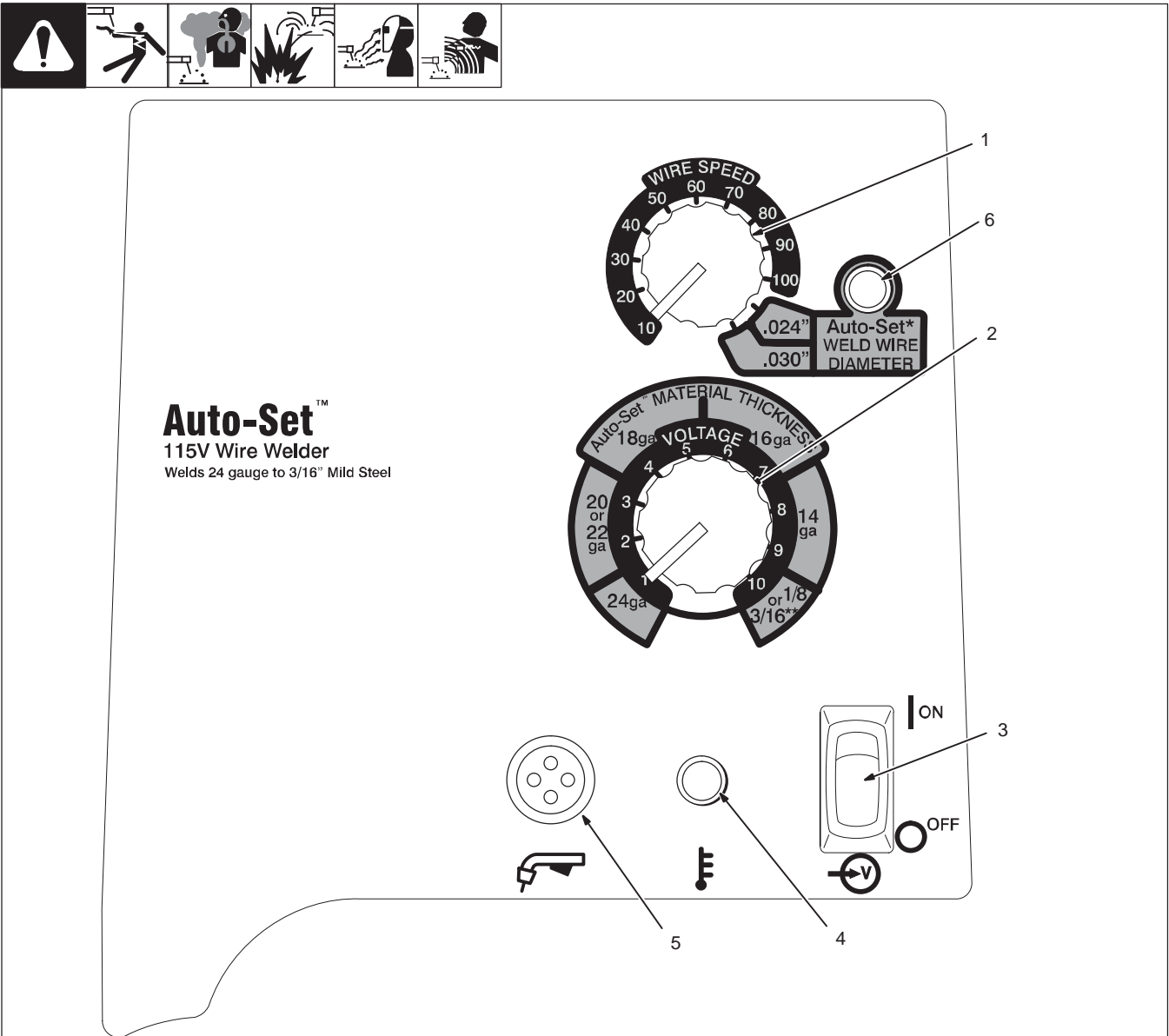

227 748-C

1 Wire Speed Control

Turn control clockwise inside white scale (10-100) to increase wire feed speed. (see weld parameter chart in welding power source or Section 5-4, 5-5, 5-6, 5-7, or 5-8 as applicable).

2 Voltage Control

Turn control clockwise inside white scale (1-10) to increase voltage (see weld parameter chart in welding power source or Section 5-4, 5-5, 5-6, 5-7, or 5-8 as applicable).

3 Power Switch

4 Over Temperature Light

5 Gun Trigger Receptacle

6 Auto-Set™ Light

To use Auto-Set™ mode, rotate Wire Speed control inside blue area for the applicable Weld Wire Diameter, Auto-Set™ light will turn on, and the unit will

provide the appropriate wire feed speed for the material thickness selected using the Voltage control (see Section 5-4).

Rotate Voltage control inside blue scale (24 ga to 1/8") for the applicable material thickness and the unit will provide the appropriate voltage within the range of the selected material thickness and the selected Weld Wire Diameter (see Section 5-4).

5-2. Controls For 115 VAC Model

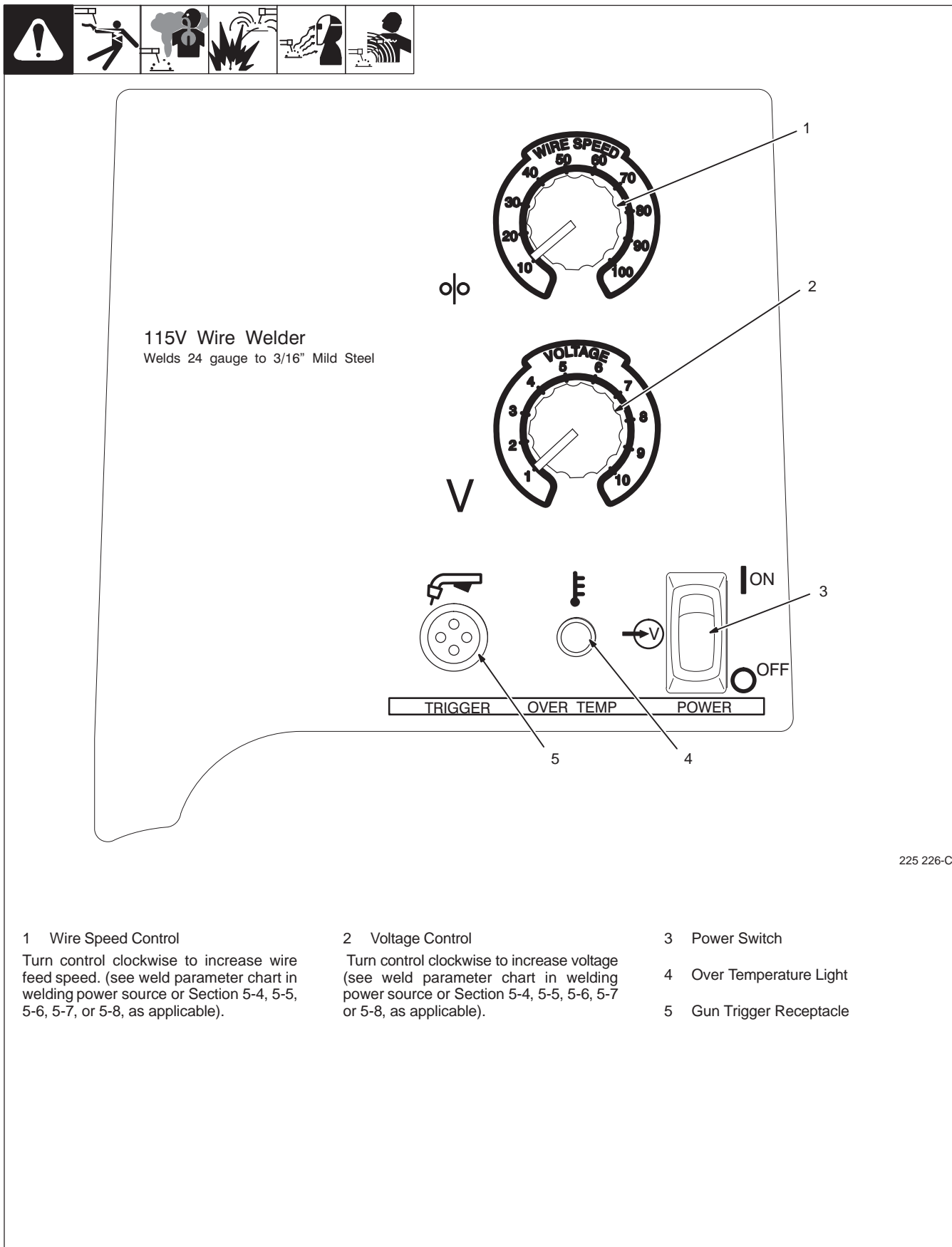

1 Wire Speed Control

Turn control clockwise to increase wire feed speed. (see weld parameter chart in welding power source or Section 5-4, 5-5, 5-6, 5-7, or 5-8, as applicable).

2 Voltage Control

Turn control clockwise to increase voltage (see weld parameter chart in welding power source or Section 5-4, 5-5, 5-6, 5-7 or 5-8, as applicable).

3 Power Switch

4 Over Temperature Light

5 Gun Trigger Receptacle

5-3. Controls For 230 VAC Model

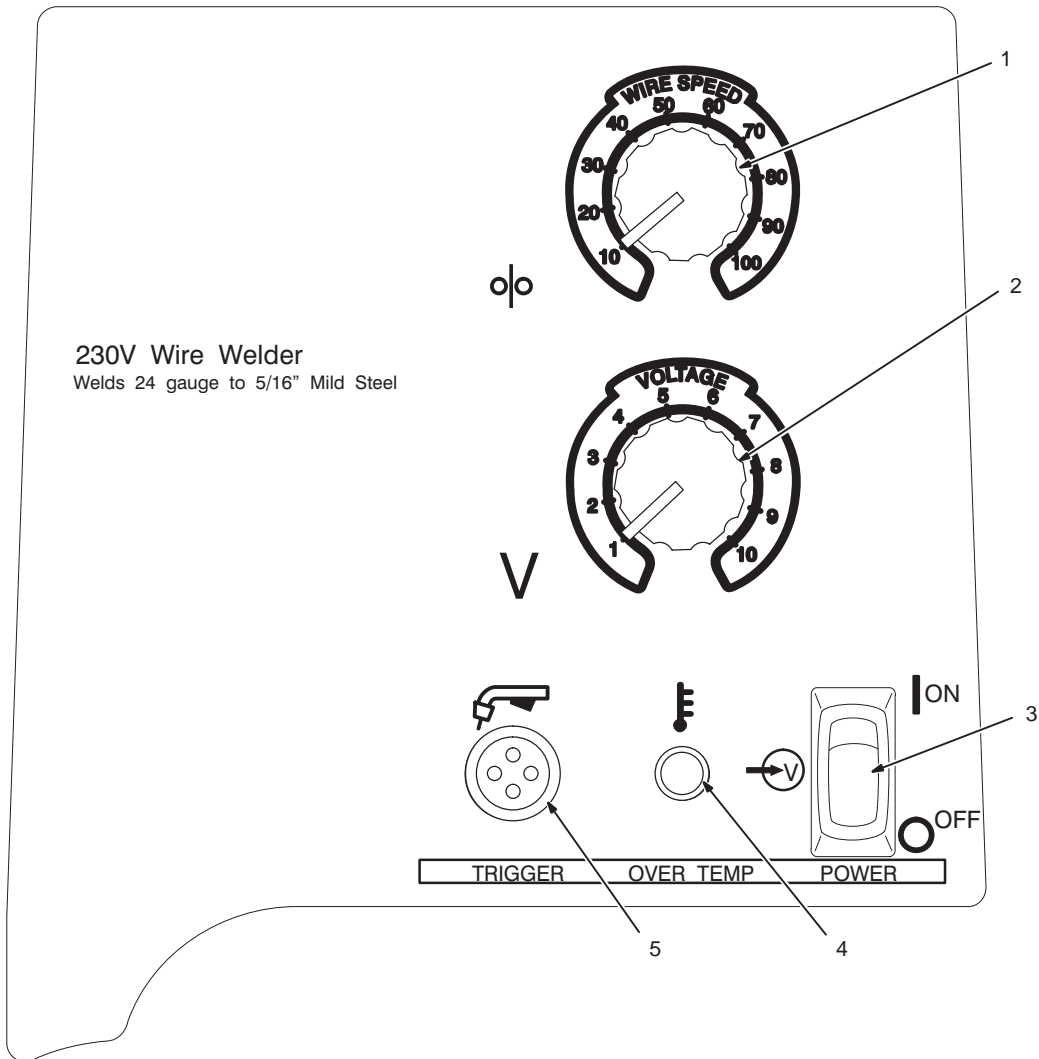

225 227-C

1 Wire Speed Control

Turn control clockwise to increase wire feed speed. (see weld parameter chart in welding power source or Section 5-5, 5-4, 5-6, 5-7 or 5-8, as applicable).

2 Voltage Control

Turn control clockwise to increase voltage (see weld parameter chart in welding power source or Section 5-5, 5-4, 5-6, 5-7 or 5-8 as applicable).

3 Power Switch

4 Over Temperature Light

5 Gun Trigger Receptacle

5-4. Weld Parameter Chart For 115 VAC Model w/Auto-Set™

Auto-Set™ – SIMPLE SETUP FOR WELDING MILD STEEL

Example: .030" diameter wire, welding 18 ga. material.

1. Activate Auto-Set™ by selecting the diameter of the welding wire with the WIRE SPEED knob. Auto-Set light comes on.
2. Select thickness of the mild steel being welded with the VOLTAGE knob. Setup complete.

USE 75% ARGON / 25% CO2 SHIELDING GAS

Material	Suggested Wire Types, Polarity	Suggested Shielding Gases (Flow Rate of 20-30 cfh)	Wire Sizes (Diameters)
Steel	Solid Wire ER70S-6 (DCEP)	C ₂₅ Gas Mixture 75% Ar / 25% CO ₂	.024" (0.6 mm)
			.030" (0.8 mm)
	Solid Wire ER70S-6 (DCEP)	100% CO ₂	.024" (0.6 mm)
			.030" (0.8 mm)
Flux Core E71T-11 (DCEN)	No Shielding Gas required. Good for windy or outdoor applications.	.030" (0.8 mm)	
		.035" (0.9 mm)	
Stainless Steel	Stainless Steel (DCEP)	Tri-Mix 90% He / 7.5% Ar / 2.5% Co ₂	.024" (0.6 mm)
			.030" (0.8 mm)

Selecting Wire, Gas and Control Settings for Aluminum with optional Spool Gun. Order part no. 300371

Aluminum w/ Opt. Spool Gun	Aluminum 4043ER	100% Argon	.030" (0.8 mm) .035" (0.9 mm)
-------------------------------	--------------------	------------	----------------------------------

NOTE: Settings are approximate. Adjust as required.
 "—" Means not recommended.
 "*" Thicker materials can be welded using proper technique, joint preparation and multiple passes.

IMPORTANT: Match drive roll groove to diameter of wire being used.
 Set Tension knob setting to 3 at start. Adjust tension per instructions in the manual.

Manual Setup

Refer to chart below to select Voltage and Wire Speed based on thickness of metal being welded.

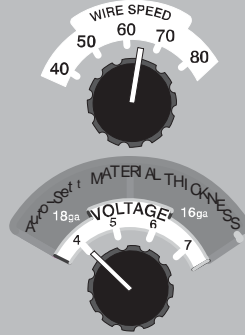

1. Number on right of slash is Wire Speed Knob Setting.
(Example: 4 / 65)

2. Number on left of slash is Voltage Knob Setting.
(Example: 4 / 65)

CHANGING POLARITY

DCEP
Electrode Positive
For Solid Wire

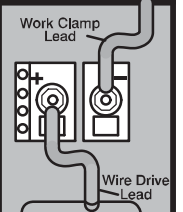

DCEN
Electrode Negative
For Flux Core Wire

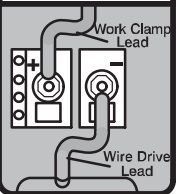

	24 ga. (0.6 mm)	22 ga. (0.8 mm)	20 ga. (0.9 mm)	18 ga. (1.2 mm)	16 ga. (1.6 mm)	14 ga. (2.8 mm)	1/8" (3.2 mm)	3/16" (4.8 mm)
	2/40	3/50	3/50	4/65	4.5/70	5.5/80	10/90	*
	2/32	3/40	3/40	4/45	5/55	5.5/60	10/65	*
	---	--	4/45	5/60	5.5/65	7/80	10/80	*
	---	--	4/35	5/40	5.5/45	6.5/50	10/60	*
	---	--	---	2/35	3/40	5.5/60	10/65	*
	---	--	---	2.5/32	3/35	4.5/45	10/50	10/50
	---	--	4.5/50	4.5/50	6/75	7/95	10/95	--
	---	--	4/40	5/50	6/60	7/70	10/75	*

---	--	--	3/90	3/90	10/100	---	---
---	--	--	3/70	3/75	10/90	---	---

M-10 (#195605) Torch Consumables:				Quick Change Dual Grooved Drive Rolls:		
Nozzles:	Tip Adapter:	Contact Tips:	Liners:	Wire Diameters	V-Smooth	V-Knurled *
#169715	#169716	.024"(0.6mm)#087299	.024" (0.6mm) #194010	.024"(0.6mm)	#220179	
		.030"(0.8mm)#000067	.030-.035"(0.8-0.9mm)#194011	.030"(0.8mm)	#220179	#202926
		.035"(0.9mm)#000068	.035-.045"(0.9-1.2mm)#194012	.035"(0.9mm)	#220179	#202926
* For Flux Core or Stainless Wire						

227 931- H

5-5. Weld Parameter Chart For 115 VAC Model w/Factory Set Non-Wire Speed Tracking Mode

Refer to chart below to select Voltage and Wire Speed based on thickness of material being welded.

1. Number on left of slash is Voltage Knob Setting.
(Example: 4.5 / 65)

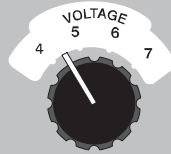

2. Number on right of slash is Wire Speed Knob Setting.
(Example: 4.5 / 65)

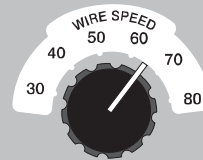

Material	Suggested Wire Types, Polarity	Suggested Shielding Gases (Flow Rate of 20-30 cfh)	Wire Sizes (Diameters)
Steel	Solid Wire ER70S-6 (DCEP)	C ₂₅ Gas Mixture 75% Ar / 25% CO ₂	.024" (0.6 mm) .030" (0.8 mm)
	Solid Wire ER70S-6 (DCEP)	100% CO ₂	.024" (0.6 mm) .030" (0.8 mm)
	Flux Core E71T-11 (DCEN)	No Shielding Gas required. Good for outdoor applications.	.030" (0.8 mm) .035" (0.9 mm)
Stainless Steel	Stainless Steel (DCEP)	Tri-Mix 90% He / 7.5% Ar / 2.5% CO ₂	.024" (0.6 mm) .030" (0.8 mm)

Selecting Wire, Gas and Control Settings for Aluminum

Aluminum w/ Opt. Spool Gun	Aluminum 4043ER	100% Argon	.030" (0.8 mm) .035" (0.9 mm)
----------------------------	-----------------	------------	----------------------------------

M-10 (#195605) Torch Consumables:

Nozzles:	Tip Adapter:	Contact Tips:	Liners:
#169715	#169716	.024" (0.6 mm) #087299	.024" (0.6 mm) #194010
		.030" (0.8 mm) #000067	.030 - .035" (0.8 - 0.9 mm) #194011
		.035" (0.9 mm) #000068	.035 - .045" (0.9 - 1.2 mm) #194012

Selecting Wire, Gas and Control Settings

NOTE: Settings are approximate. Adjust as required.

“---” Means not recommended.

“*” Thicker materials can be welded using proper technique, joint preparation and multiple passes.

IMPORTANT: Match drive roll groove to diameter of wire being used.
Set Tension knob setting to 3 at start. Adjust tension per instructions in the manual.

24 ga. (0.6 mm)	22 ga. (0.8 mm)	20 ga. (0.9 mm)	18 ga. (1.2 mm)	16 ga. (1.6 mm)	14 ga. (2.8 mm)	1/8" (3.2 mm)	3/16" (4.8 mm)
2.5/35	3.5/45	3.5/45	4/55	4.5/65	5.5/80	10/90	*
2.5/28	3/30	3/30	4.5/40	5/45	5.5/50	10/45	*
---	---	4.5/35	5.5/45	5.5/55	8/65	10/60	*
---	---	5/22	5.5/30	6/35	6.5/40	10/30	*
---	---	---	2/30	3.5/40	5.5/50	10/45	*
---	---	---	2/25	3.5/25	6/40	8/40	10/32
---	---	5/40	6/50	6.5/70	7.5/85	10/80	---
---	---	5/30	5/35	6/60	7/70	10/60	*

with optional Spool Gun, Order part no. 300371

---	---	---	2/60	3/70	10/75	---	---
---	---	---	3/60	3.5/65	10/70	---	---

Quick Change Dual Grooved Drive Rolls:

Wire Diameters	V-Smooth	V-Knurled *
.024" (0.6 mm)	#220179	
.030" (0.8 mm)	#220179	#202926
.035" (0.9 mm)	#220179	#202926

* For Flux Core or Stainless Wire

CHANGING POLARITY

DCEP
Electrode Positive
For Solid Wire

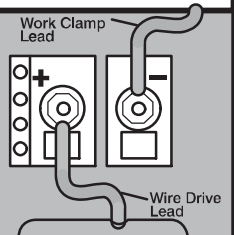

DCEN
Electrode Negative
For Flux Core Wire

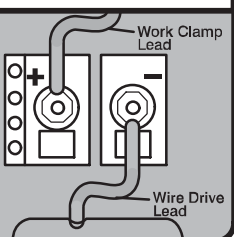

224 940-D

5-6. Weld Parameter Chart For 115 VAC Model w/Wire Speed Tracking Mode

Refer to chart below to select Voltage and Wire Speed based on thickness of material being welded.

1. Number on left of slash is Voltage Knob Setting.
(Example: 4.5/65)

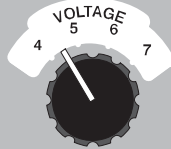

2. Number on right of slash is Wire Speed Knob Setting.
(Example: 4.5 / 65)

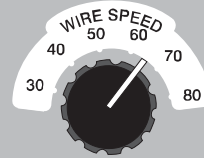

Material	Suggested Wire Types, Polarity	Suggested Shielding Gases (Flow Rate of 20-30 cfh)	Wire Sizes (Diameters)
Steel	Solid Wire ER70S-6 (DCEP)	C ₂₅ Gas Mixture 75% Ar / 25% CO ₂	.024" (0.6 mm) .030" (0.8 mm)
	Solid Wire ER70S-6 (DCEP)	100% CO ₂	.024" (0.6 mm) .030" (0.8 mm)
	Flux Core E71T-11 (DCEN)	No Shielding Gas required. Good for outdoor applications.	.030" (0.8 mm) .035" (0.9 mm)
Stainless Steel	Stainless Steel (DCEP)	Tri-Mix 90% He / 7.5% Ar / 2.5% CO ₂	.024" (0.6 mm) .030" (0.8 mm)

M-10 (#195605) Torch Consumables:

Nozzles:	Tip Adapter:	Contact Tips:	Liners:
#169715	#169716	.024" (0.6 mm) #087299	.024" (0.6 mm) #194010
		.030" (0.8 mm) #000067	.030 - .035" (0.8 - 0.9 mm) #194011
		.035" (0.9 mm) #000068	.035 - .045" (0.9 - 1.2 mm) #194012

To enable wire speed tracking, proceed as follows:

1. Turn Power switch off.
2. Rotate Voltage knob to minimum.
3. Rotate Wire Speed knob to maximum.
4. Hold gun trigger in while turning on Power switch.

To verify wire speed tracking is on, open drive roll pressure arm, pull trigger, and rotate Voltage knob from min. to max. Drive roll speed will change rpm if tracking is on.

Selecting Wire, Gas and Control Settings

NOTE: Settings are approximate. Adjust as required.

“---” Means not recommended.

“**” Thicker materials can be welded using proper technique, joint preparation and multiple passes.

IMPORTANT: Match drive roll groove to diameter of wire being used.
Set Tension knob setting to 3 at start. Adjust tension per instructions in the manual.

24 ga. (0.6 mm)	22 ga. (0.8 mm)	20 ga. (0.9 mm)	18 ga. (1.2 mm)	16 ga. (1.6 mm)	14 ga. (2.8 mm)	1/8" (3.2 mm)	3/16" (4.8 mm)
2.5/35	3.5/45	3.5/45	4/55	4.5/65	5.5/80	10/90	*
2.5/28	3/30	3/30	4.5/40	5/45	5.5/50	10/45	*
---	---	4.5/35	5.5/45	5.5/55	8/65	10/60	*
---	---	5/22	5.5/30	6/35	6.5/40	10/30	*
---	---	---	2/30	3.5/40	5.5/50	10/45	*
---	---	---	2/25	3.5/25	6/40	8/40	10/32
---	---	5/40	6/50	6.5/70	7.5/85	10/80	---
---	---	5/30	5/35	6/60	7/70	10/60	*

Quick Change Dual Grooved Drive Rolls:

Wire Diameters	V-Smooth	V-Knurled *
.024" (0.6 mm)	#220179	
.030" (0.8 mm)	#220179	#202926
.035" (0.9 mm)	#220179	#202926

* For Flux Core or Stainless Wire

CHANGING POLARITY

DCEP
Electrode Positive
For Solid Wire

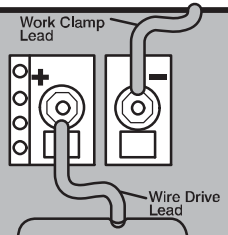

DCEN
Electrode Negative
For Flux Core Wire

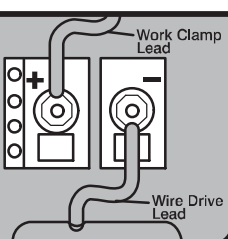

232 016-A

To disable wire speed tracking, proceed as follows:

1. Turn Power switch off.
2. Rotate Voltage knob to maximum.
3. Rotate Wire Speed knob to minimum.
4. Hold gun trigger in while turning on Power switch.

☞ To verify wire speed tracking is off, open drive roll pressure arm, pull trigger, and rotate Voltage knob from min. to max. Drive roll speed will have minimal change in rpm if tracking is off.

5-7. Weld Parameter Chart For 230 VAC Model w/Factory Set Non-Wire Speed Tracking Mode

Refer to chart below to select Voltage and Wire Speed based on thickness of material being welded.

1. Number on left of slash is Voltage Knob Setting.
Example: 4.5 / 55



2. Number on right of slash is Wire Speed Knob Setting.
(Example: 4.5 / 55)

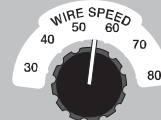

Material	Suggested Wire Types, Polarity	Suggested Shielding Gases (Flow Rate of 20-30 cfh)	Wire Sizes (Diameters)
Steel	Solid Wire ER70S-6 (DCEP)	C ₂₅ Gas Mixture 75% Ar / 25% CO ₂	.024" (0.6 mm)
			.030" (0.8 mm)
			.035" (0.9 mm)
	Solid Wire ER70S-6 (DCEP)	100% CO ₂	.024" (0.6 mm)
			.030" (0.8 mm)
			.035" (0.9 mm)
Flux Core E71T-11 (DCEN)	No Shielding Gas required. Good for outdoor applications.	.030" (0.8 mm)	
		.035" (0.9 mm)	
		.045" (1.2 mm)	
Stainless Steel	Stainless Steel (DCEP)	Tri-Mix 90% He / 7.5% Ar / 2.5% CO ₂	.024" (0.6 mm)
			.030" (0.8 mm)
			.035" (0.9 mm)

Selecting Wire, Gas and Control Settings for Aluminum

Aluminum Spool Gun	Aluminum 4043ER	100% Argon	.030" (0.8 mm)
			.035" (0.9 mm)

M-10 (#195605) Torch Consumables:			
Nozzles: #169715	Tip Adapter: #169716	Contact Tips: .024" (0.6 mm) #087299 .030" (0.8 mm) #000067 .035" (0.9 mm) #000068 .045" (1.2 mm) #000069	Liners: .024" (0.6 mm) #194010 .030 - .035" (0.8 - 0.9 mm) #194011 .035 - .045" (0.9 - 1.2 mm) #194012

Selecting Wire, Gas and Control Settings

NOTE: Settings are approximate. Adjust as required.
 "—" Means not recommended.

Thicker materials can be welded using proper technique,
 joint preparation and multiple passes.

IMPORTANT: Match drive roll groove to diameter of wire being used. Set Tension
 knob setting to 3 at start. Adjust tension per instructions in the manual.

24 ga. (0.6 mm)	22 ga. (0.8 mm)	20 ga. (0.9 mm)	18 ga. (1.2 mm)	16 ga. (1.6 mm)	14 ga. (2.8 mm)	1/8" (3.2 mm)	3/16" (4.8 mm)	1/4" (6.4 mm)	5/16" (7.9 mm)
1.5/20	2/25	2/25	2.5/30	3/45	3.5/60	4/70	6/100	---	---
1.5/15	2/20	2/20	2.5/30	3/35	3.5/40	4.5/55	6/75	6/80	10/95
---	2/12	2/15	2.5/20	3/25	3.5/30	4.5/45	6/55	6.5/60	10/70
---	---	3.5/25	3.5/25	4/40	4.5/50	5/60	7/85	---	---
---	---	3/15	3.5/20	4/25	4.5/35	5.5/45	6/55	6.5/65	10/75
---	---	---	3/12	4/20	4.5/30	5.5/35	6/40	6.5/50	10/55
---	---	---	1/15	2/20	3.5/35	4/45	6/65	6.5/75	---
---	---	---	1/10	2/15	3/25	4/35	6/55	7/60	10/65
---	---	---	---	2.5/10	3/15	4/25	6/35	7/40	10/45
---	---	3.5/30	3.5/45	4/50	4.5/70	5/80	6/95	---	---
---	---	3.5/25	3.5/28	4/45	5/60	5/70	6/85	7.5/95	---
---	---	---	2.5/20	3.5/25	4/40	4.5/50	6/65	7.5/80	---

with optional Spool Gun, Order part no. 300371

---	---	---	2/70	2/70	4/70	5/70	8/95	10/100	---
---	---	---	---	2.5/65	4/60	5/65	8/90	10/90	---

Quick Change Dual Grooved Drive Rolls:

Wire Diameters	V-Smooth	V-Knurled *
.024" (0.6 mm)	#220179	
.030" (0.8 mm)	#220179	#202926
.035" (0.9 mm)	#220179	#202926
.045" (1.2 mm)		#202926* For Flux Core or Stainless Wire

CHANGING POLARITY

DCEP
 Electrode Positive
 For Solid Wire

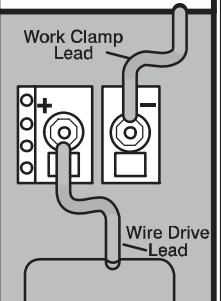

DCEN
 Electrode Negative
 For Flux Core Wire

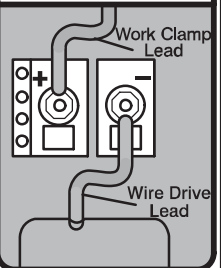

225 229-F

5-8. Weld Parameter Chart For 230 VAC Model w/Wire Speed Tracking Mode

Refer to chart below to select Voltage and Wire Speed based on thickness of material being welded.

1. Number on left of slash is Voltage Knob Setting.
Example: 4.5 / 65

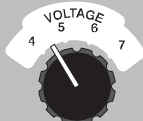

2. Number on right of slash is Wire Speed Knob Setting.
(Example: 4.5 / 65)

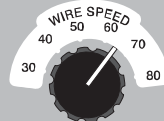

Material	Suggested Wire Types, Polarity	Suggested Shielding Gases (Flow Rate of 20-30 cfh)	Wire Sizes (Diameters)
Steel	Solid Wire ER70S-6 (DCEP)	C ₂₅ Gas Mixture 75% Ar / 25% CO ₂	.024" (0.6 mm)
			.030" (0.8 mm)
			.035" (0.9 mm)
	Solid Wire ER70S-6 (DCEP)	100% CO ₂	.024" (0.6 mm)
			.030" (0.8 mm)
			.035" (0.9 mm)
	Flux Core E71T-11 (DCEN)	No Shielding Gas required. Good for outdoor applications.	.030" (0.8 mm)
			.035" (0.9 mm)
			.045" (1.2 mm)
Stain- less Steel	Stain- less Steel (DCEP)	Tri-Mix 90% He / 7.5% Ar / 2.5% CO ₂	.024" (0.6 mm)
			.030" (0.8 mm)
			.035" (0.9 mm)

M-10 (#195605) Torch Consumables:

Nozzles:	Tip Adapter:	Contact Tips:	Liners:
#169715	#169716	.024" (0.6 mm) #087299	.024" (0.6 mm) #194010
		.030" (0.8 mm) #000067	.030 - .035" (0.8 - 0.9 mm) #194011
		.035" (0.9 mm) #000068	.035 - .045" (0.9 - 1.2 mm) #194012
		.045" (1.2 mm) #000069	.035 - .045" (0.9 - 1.2 mm) #194012

To enable wire speed tracking, proceed as follows:

1. Turn Power switch off.
2. Rotate Voltage knob to minimum.
3. Rotate Wire Speed knob to maximum.
4. Hold gun trigger in while turning on Power switch.

☞ To verify wire speed tracking is on, open drive roll pressure arm, pull trigger, and rotate Voltage knob from min. to max. Drive roll speed will change rpm if tracking is on.

Selecting Wire, Gas and Control Settings

NOTE: Settings are approximate. Adjust as required.

“---” Means not recommended.

“**” Thicker materials can be welded using proper technique, joint preparation and multiple passes.

IMPORTANT: Match drive roll groove to diameter of wire being used. Set Tension knob setting to 3 at start. Adjust tension per instructions in the manual.

24 ga. (0.6 mm)	22 ga. (0.8 mm)	20 ga. (0.9 mm)	18 ga. (1.2 mm)	16 ga. (1.6 mm)	14 ga. (2.8 mm)	1/8" (3.2 mm)	3/16" (4.8 mm)	1/4" (6.4 mm)	5/16" (7.9 mm)
2/22	2.5/28	2.5/28	3/30	3.5/45	4/50	4.5/70	7/100	---	---
2.5/10	2.5/15	3/20	3.5/30	4/35	4.5/40	5/50	5.5/60	6.5/70	10/60
---	2.5/15	2.5/15	3.5/20	4/25	4.5/30	4.5/35	6/50	6.5/55	10/45
---	---	3.5/20	3.5/25	4/40	4.5/40	5/50	5.5/65	---	---
---	---	3.5/10	4/10	4.5/20	5/25	5.5/35	6.5/40	7.5/50	---
---	---	---	4/10	4/18	5/20	5/25	6/25	6/35	---
---	---	---	1/15	2/20	3/30	4/40	5.5/50	7/60	---
---	---	---	1/15	2/20	3/20	4/35	6/45	6.5/55	10/40
---	---	---	---	2/10	3/15	4/20	6/30	6.5/30	10/20
---	---	4/25	4/40	5/45	5/65	5/70	6/85	---	---
---	---	4/10	4/20	4/25	4/30	4.5/45	5/50	5.5/60	---
---	---	---	3.5/15	4/25	4.5/40	5/40	5.5/55	10/50	---

CHANGING POLARITY

DCEP
Electrode Positive
For Solid Wire

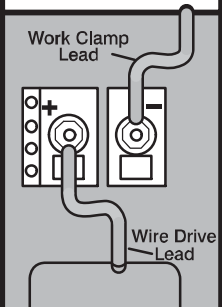

DCEN
Electrode Negative
For Flux Core Wire

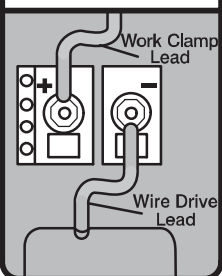

Quick Change Dual Grooved Drive Rolls:

Wire Diameters	V-Smooth	V-Knurled *
.024" (0.6 mm)	#220179	
.030" (0.8 mm)	#220179	#202926
.035" (0.9 mm)	#220179	#202926
.045" (1.2 mm)		#202926 * For Flux Core or Stainless Wire

232 017-A

To disable wire speed tracking, proceed as follows:

1. Turn Power switch off.
2. Rotate Voltage knob to maximum.
3. Rotate Wire Speed knob to minimum.
4. Hold gun trigger in while turning on Power switch.

☞ To verify wire speed tracking is off, open drive roll pressure arm, pull trigger, and rotate Voltage knob from min. to max. Drive roll speed will have minimal change in rpm if tracking is off.

SECTION 6 – MAINTENANCE & TROUBLESHOOTING

6-1. Routine Maintenance

				▲ Disconnect power before maintaining.	<i>Maintain more often during severe conditions.</i>
	✓ = Check ◆ = Change ● = Clean ☆ = Replace * To be done by Factory Authorized Service Agent				Reference
Every 3 Months	☆ Unreadable Labels	● Weld Terminals	✓ ☆ Weld Cables		
Every 6 Months	● Inside Unit				

6-2. Overload Protection

	<p>1 Supplementary Protector CB1 CB1 protects unit from overload. If CB1 opens, unit shuts down. Reset supplementary protector.</p>

802 441

6-3. Drive Motor Protection And Tip Saver/Short Circuit Protection



A. Drive Motor Protection

Drive motor protection circuit protects drive motor from overload. If drive motor becomes inoperative, cycle unit power off and back on again.

B. Tip Saver/Short Circuit Protection

The tip saver/short circuit protection extends contact tip life and protects internal components from damage. If contact tip is shorted to workpiece, the unit shuts down the welding output, but the fan continues to run. To resume operation, release gun trigger to reset unit. If the contact tip has stuck to the workpiece, release gun trigger, turn off unit, and remove contact tip from workpiece. Check contact tip and replace if damaged. Turn on unit to continue operation.

6-4. Changing Drive Roll Or Wire Inlet Guide



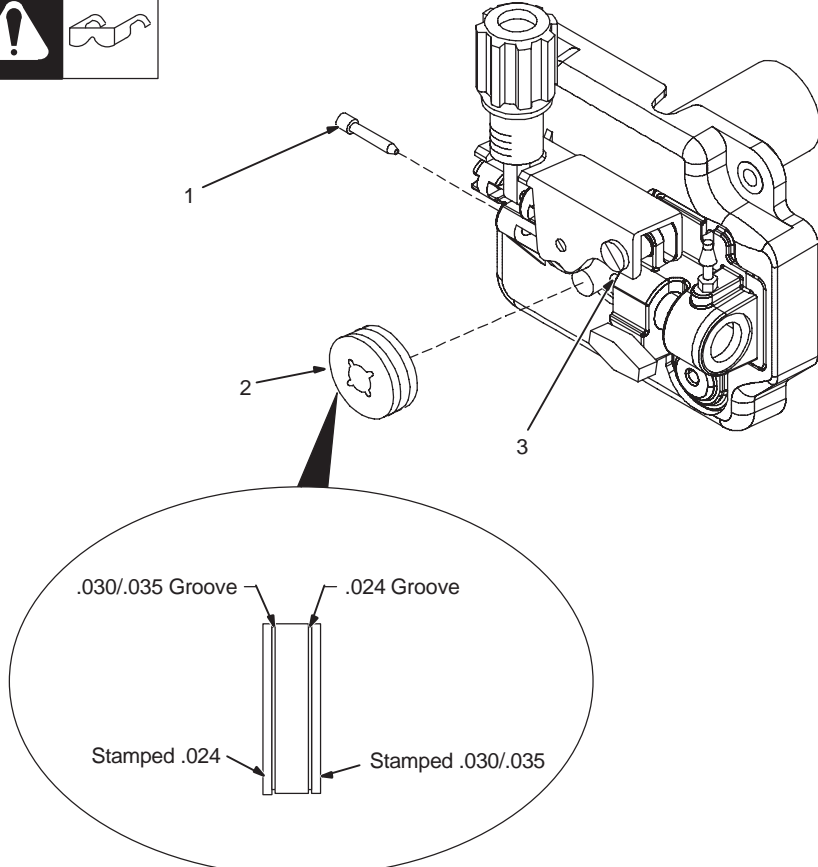



1 Inlet Wire Guide
Remove guide by pressing on barbed area or cutting off one end near housing and pulling it out of hole. Push new guide into hole from rear until it snaps in place.

2 Drive Roll
The drive roll consists of two different sized grooves. The stamped markings on the end surface of the drive roll refers to the groove on the opposite side of the drive roll. The groove closest to the motor shaft is the proper groove to thread (see Section 4-11).

3 Retaining Pin
To secure drive roll, locate open slot and push drive roll completely over retaining pin, then rotate drive roll 1/4 turn to closed slot.

802 984

6-5. Replacing Gun Contact Tip

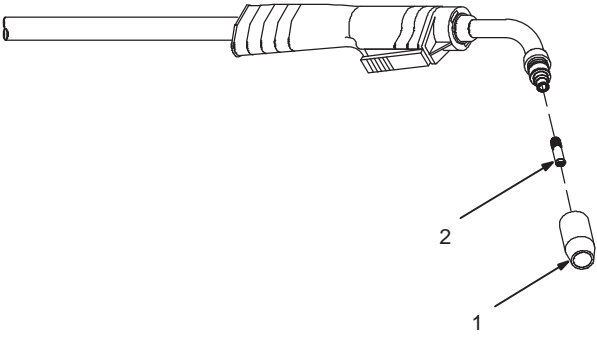

▲ Turn Off power before replacing contact tip.



1 Nozzle

2 Contact Tip

Cut off welding wire at contact tip. Remove nozzle.

Remove contact tip and install new contact tip. Reinstall nozzle.

Tools Needed:

Ref. 802 399-A

6-6. Cleaning Or Replacing Gun Liner



▲ Disconnect gun from unit.

Tools Needed:

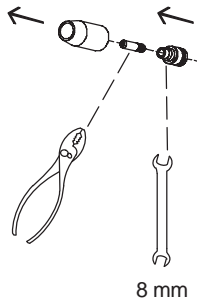
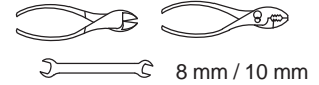

8 mm

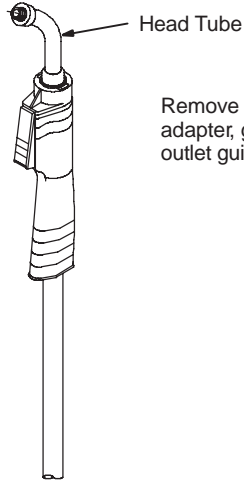

Remove nozzle, contact tip, adapter, gas diffuser, and wire outlet guide.

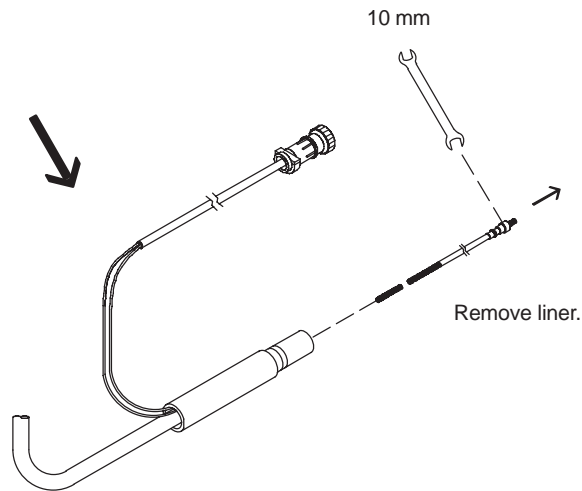

10 mm

Remove liner.

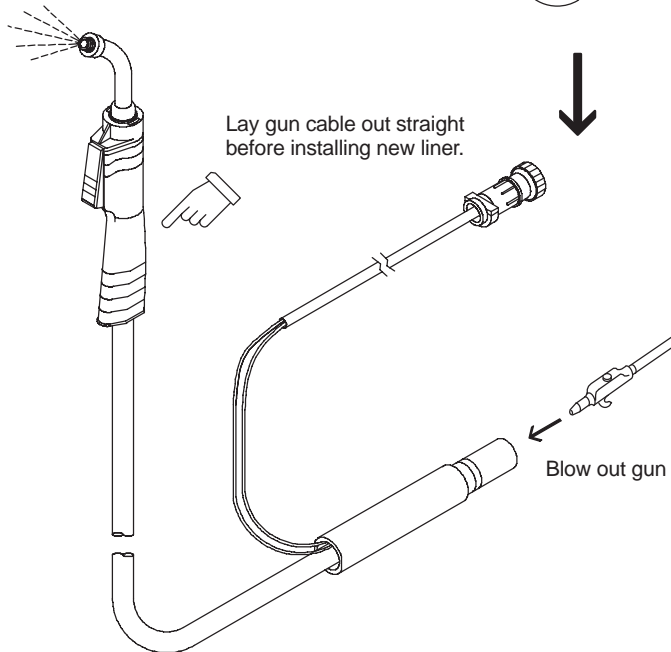

Lay gun cable out straight before installing new liner.

Blow out gun casing.

To Reassemble Gun:

Install and tighten new liner.

Cut liner off 3/4 in (20 mm) (3/8 in [9.5 mm] for aluminum) from head tube.

Install adapter, contact tip, and nozzle.

Ref. ST-802 399-A

6-7. Replacing Switch And/Or Head Tube

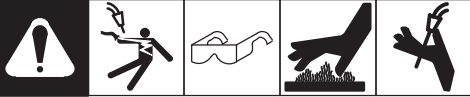

▲ Turn Off welding power source /wire feeder and disconnect gun.

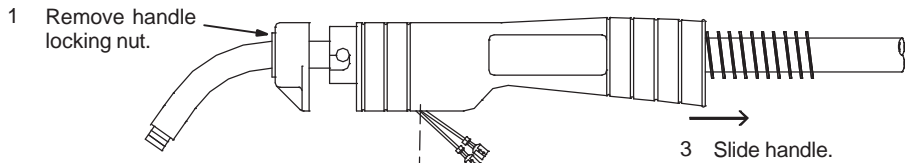

1 Remove handle locking nut.

3 Slide handle.

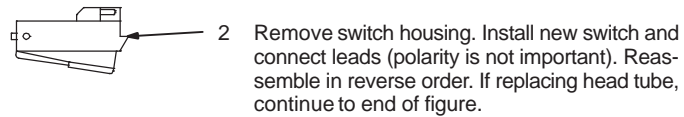

2 Remove switch housing. Install new switch and connect leads (polarity is not important). Reassemble in reverse order. If replacing head tube, continue to end of figure.

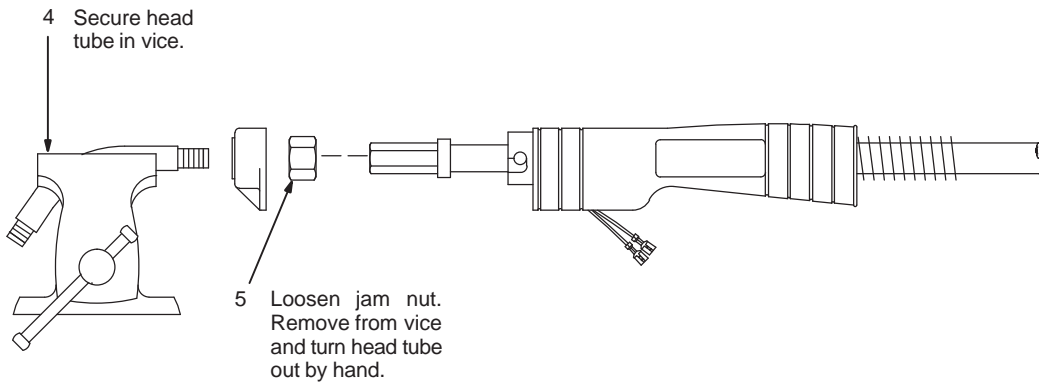

4 Secure head tube in vice.

5 Loosen jam nut. Remove from vice and turn head tube out by hand.

6 Hand-tighten head tube into cable connector.

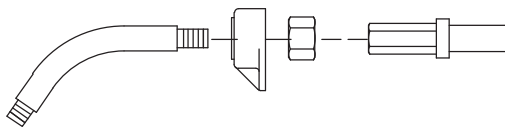

7 Place head tube in vice and tighten until nuts are tight.

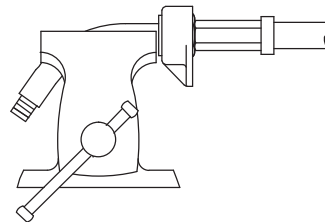

8 Remove from vice. Reposition handle and install switch housing. Secure with handle locking nut.

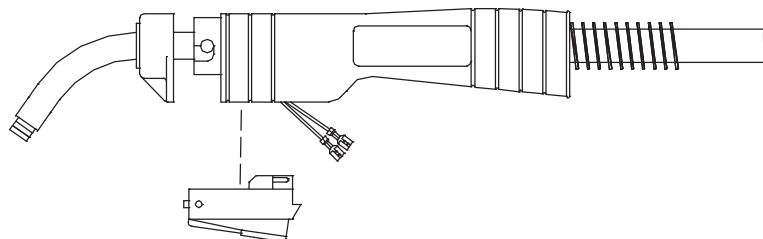

Tools Needed:



19 mm

Ref. ST-800 795-C

6-8. Troubleshooting Table



Trouble	Remedy
No weld output; wire does not feed; fan does not run.	Secure power cord plug in receptacle (see Section 4-7 or 4-8).
	Replace building line fuse or reset circuit breaker if open.
	Place Power switch in On position (see Section 5-2, 5-1, or 5-3).
	Reset welding power source supplementary protector if open.
No weld output; wire does not feed; fan motor continues to run.	Thermostat TP1 open (overheating). Allow fan to run with gun trigger switch off; thermostat closes when unit has cooled (see Section 6-3).
	Secure gun trigger plug (see Section 4-1).
	Release gun trigger and cycle unit power off and back on again.
No weld output; wire feeds.	Connect work clamp to get good metal to metal contact.
	Replace contact tip (see Section 6-5).
	Check for proper polarity connections (see Section 4-5).
	Check thumbscrew securing gun end to feed head adapter and tighten if necessary.
Low weld output.	Connect unit to proper input voltage or check for low line voltage.
	Place Power switch in On position (see Section 5-2, 5-1, or 5-3).
Electrode wire feeding stops during welding.	Straighten gun cable and/or replace damaged parts.
	Adjust drive roll pressure (see Section 4-11).
	Change to proper drive roll groove (see Section 6-4).
	Readjust hub tension (see Section 4-10).
	Be sure that wire is positioned in proper drive roll groove and wire is laying in the groove.
	Replace contact tip if blocked (see Section 6-5). Oversized tip may be required for some wires.
	Clean or replace wire inlet guide or liner if dirty or plugged (see Section 6-4 or Section 6-6).
	Replace drive roll or pressure bearing if worn or slipping (see Section 6-4).
	Secure gun trigger plug (see Section 4-1).
	Check and clear any restrictions at drive assembly and liner (see Section 6-4 or Section 6-6).
	Release gun trigger and allow gun and motor protection circuitry to reset.
Have nearest Factory Authorized Service Agent check drive motor.	

SECTION 7 – ELECTRICAL DIAGRAM

	<p>WARNING</p> <ul style="list-style-type: none"> Do not touch live electrical parts. Disconnect input power or stop engine before servicing. Do not operate with covers removed.
<p>ELECTRIC SHOCK HAZARD</p>	<ul style="list-style-type: none"> Have only qualified persons install, use, or service this unit.

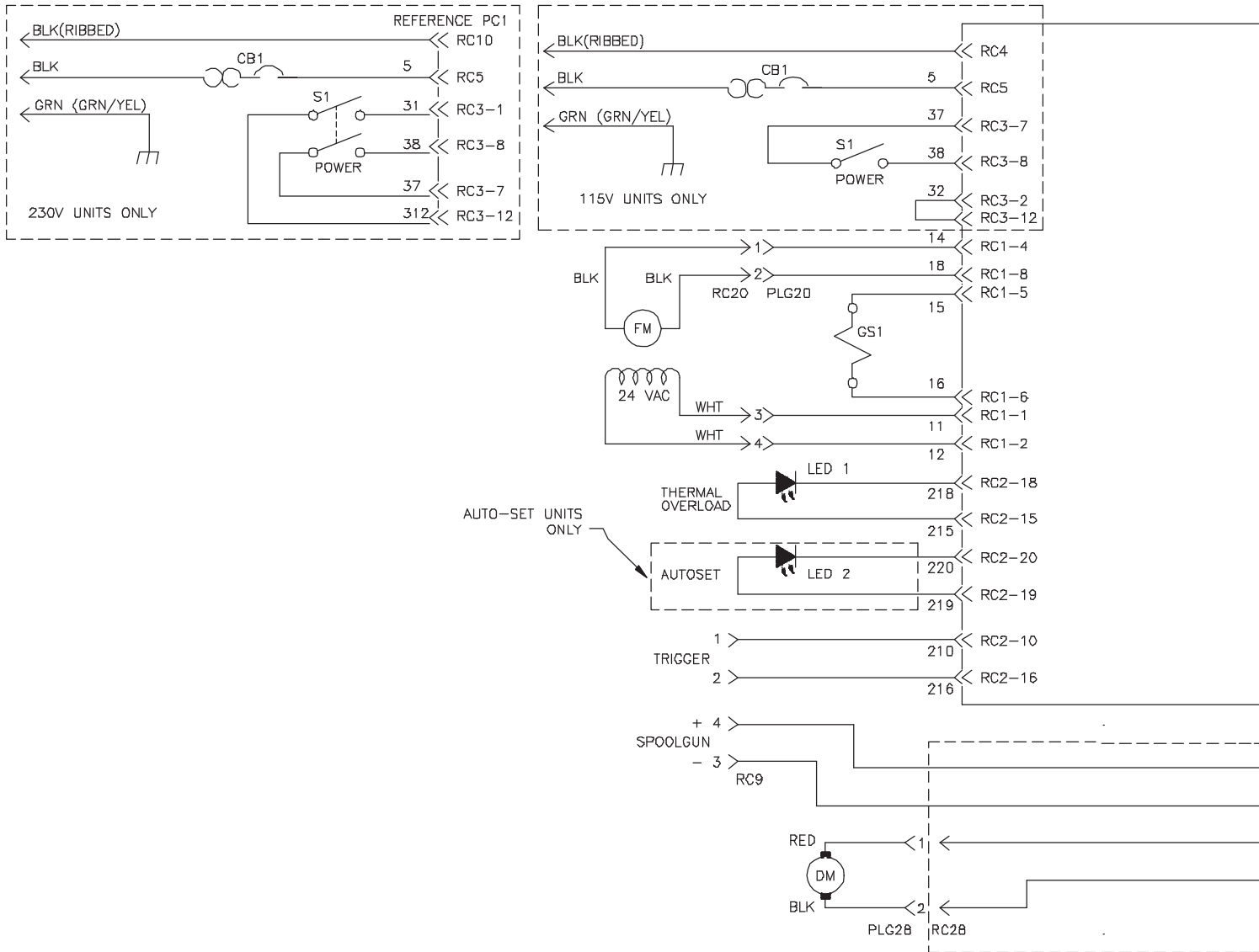
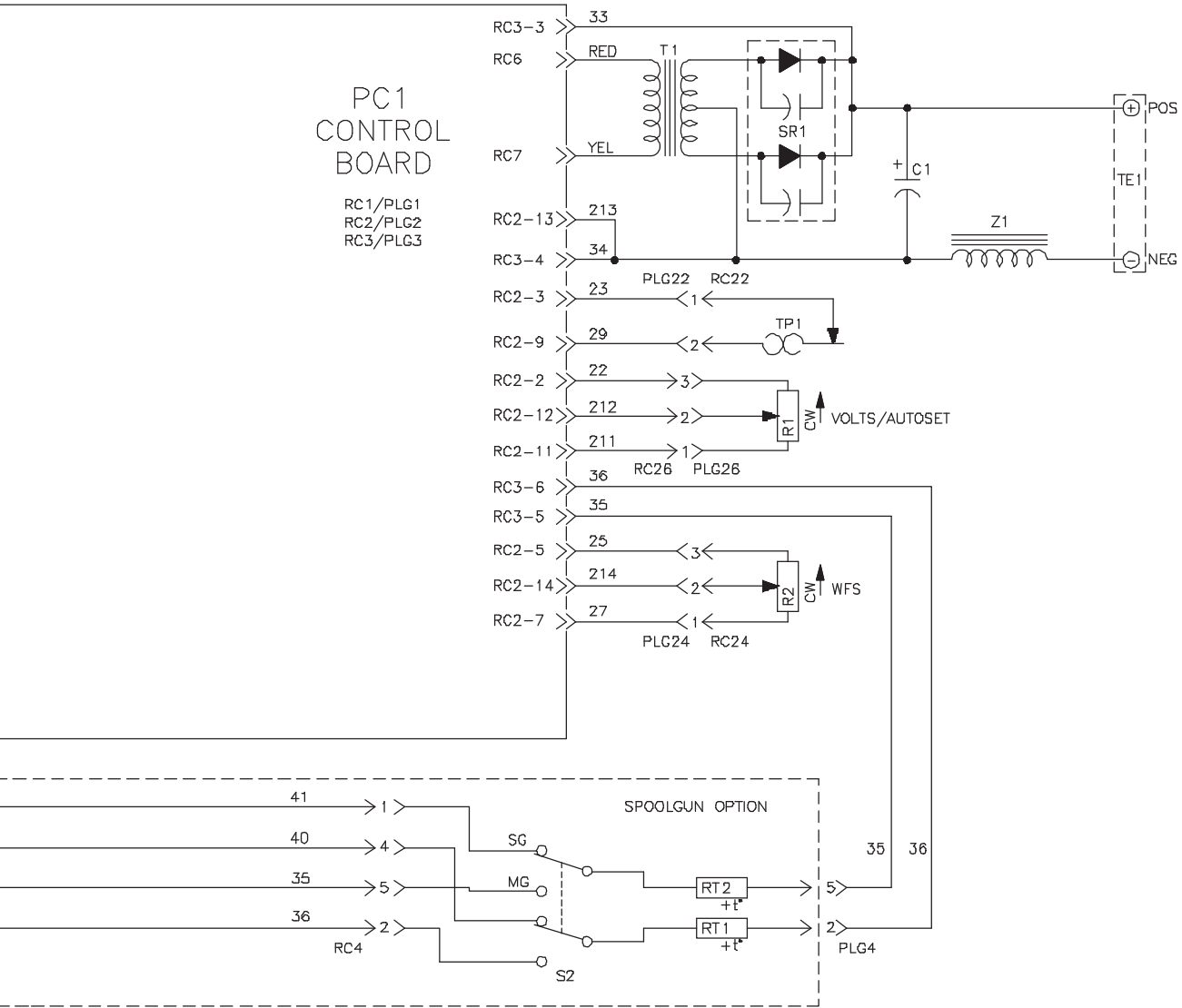

Figure 7-1. Circuit Diagram

PC1 CONTROL BOARD

RC1/PLG1
RC2/PLG2
RC3/PLG3



SECTION 8 – MIG WELDING (GMAW) GUIDELINES



8-1. Typical MIG Process Connections

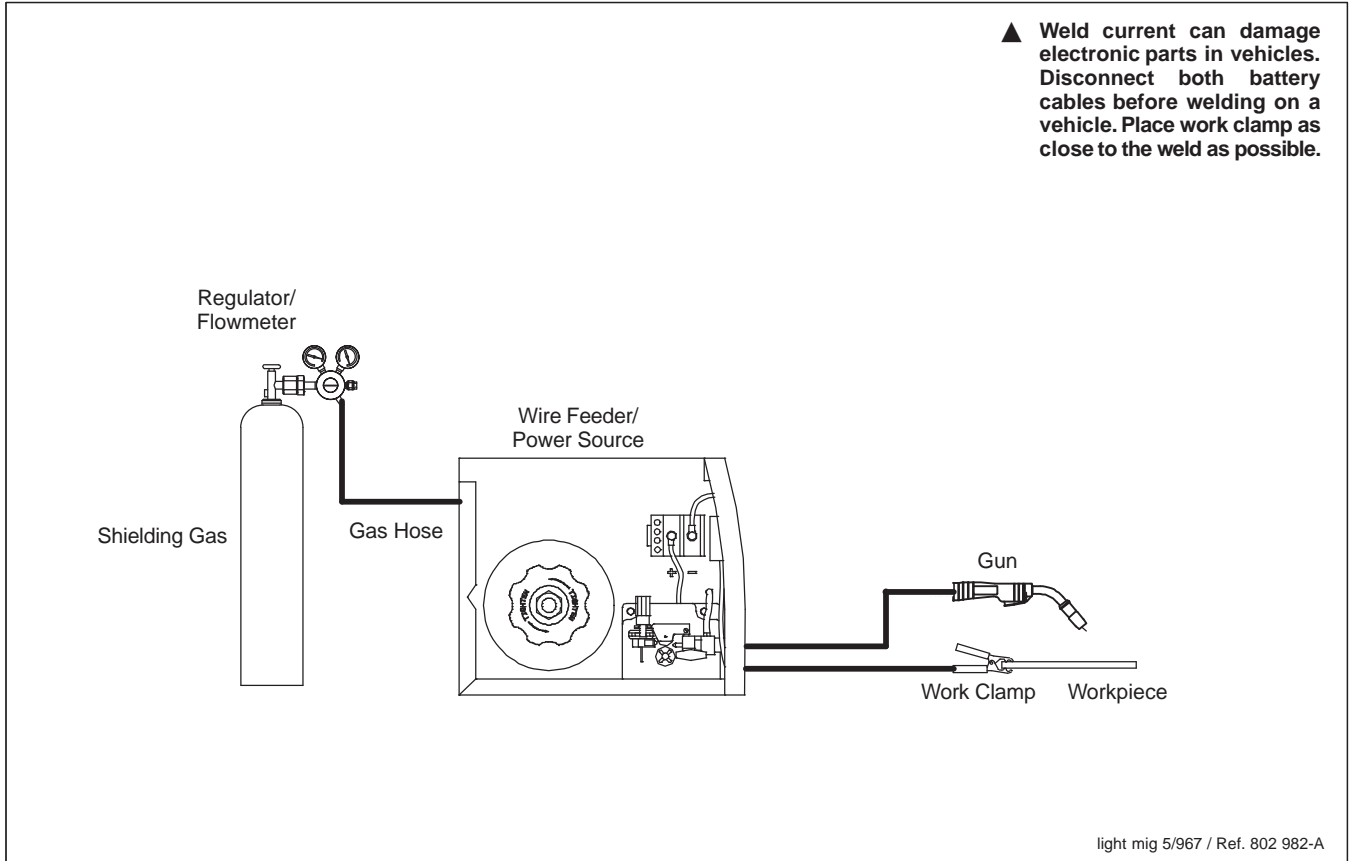

8-2. Typical MIG Process Control Settings

NOTE

These settings are guidelines only. Material and wire type, joint design, fitup, position, shielding gas, etc. affect settings. Test welds to be sure they comply to specifications.

Material thickness determines weld parameters.

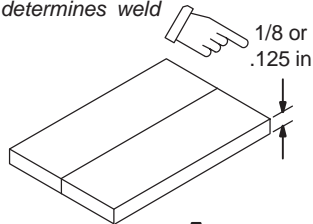

Convert Material Thickness to Amperage (A)

(.001 in = 1 ampere)
.125 in = 125 A

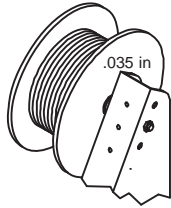

Wire Size	Amperage Range
.023 in	30 – 90 A
.030 in	40 – 145 A
.035 in	50 – 180 A

Select Wire Size

Wire Size	Recommendation	Wire Speed (Approx.)
.023 in	3.5 in per ampere	3.5 x 125 A = 437 ipm
.030 in	2 in per ampere	2 x 125 A = 250 ipm
.035 in	1.6 in per ampere	1.6 x 125 A = 200 ipm

Select Wire Speed (Amperage)

125 A based on 1/8 in material thickness

ipm = inch per minute

Low voltage: wire stubs into work
High voltage: arc is unstable (spatter)
Set voltage midway between high/low voltage.

Select Voltage

Wire speed (amperage) controls weld penetration
(wire speed = burn-off rate)

Voltage controls height and width of weld bead.

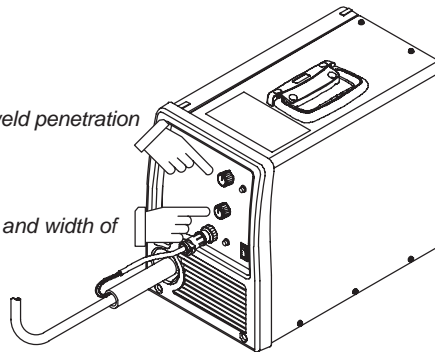

8-3. Holding And Positioning Welding Gun

NOTE

Welding wire is energized when gun trigger is pressed. Before lowering helmet and pressing trigger, be sure wire is no more than 1/2 in (13 mm) past end of nozzle, and tip of wire is positioned correctly on seam.

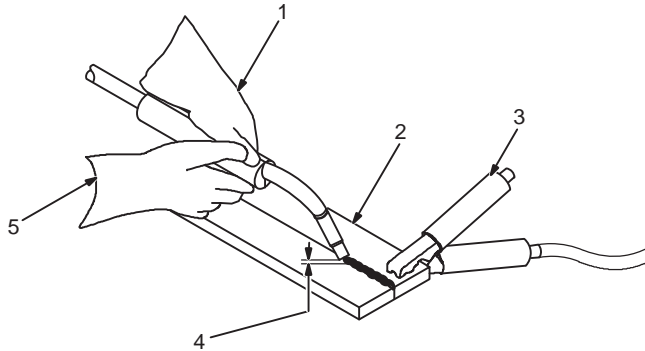

- 1 Hold Gun and Control Gun Trigger
- 2 Workpiece
- 3 Work Clamp
- 4 Electrode Extension (Stickout) 1/4 to 1/2 in (6 To 13 mm)
- 5 Cradle Gun and Rest Hand on Workpiece

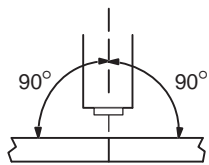

End View Of Work Angle

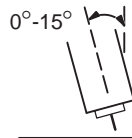

Side View Of Gun Angle

GROOVE WELDS

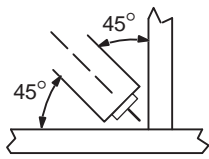

End View Of Work Angle

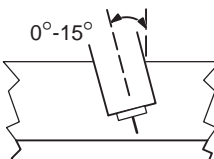

Side View Of Gun Angle

FILLET WELDS

S-0421-A

8-4. Conditions That Affect Weld Bead Shape

NOTE

Weld bead shape depends on gun angle, direction of travel, electrode extension (stickout), travel speed, thickness of base metal, wire feed speed (weld current), and voltage.

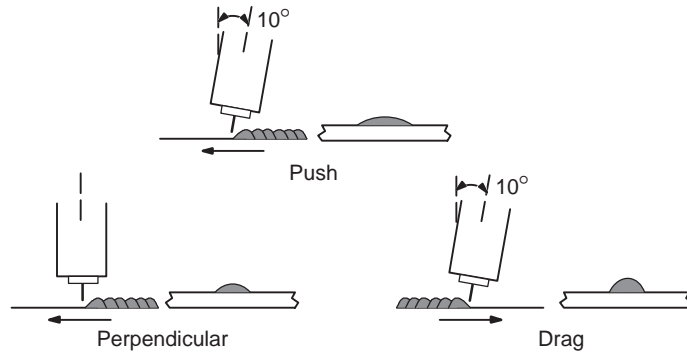

GUN ANGLES AND WELD BEAD PROFILES

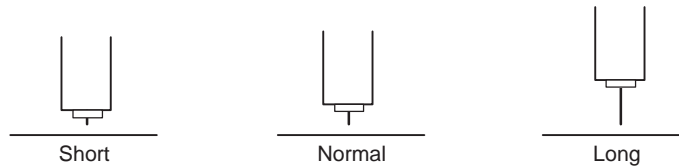

ELECTRODE EXTENSIONS (STICKOUT)

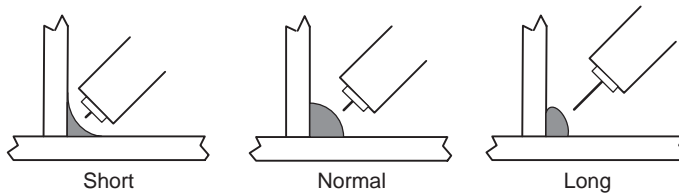

FILLET WELD ELECTRODE EXTENSIONS (STICKOUT)

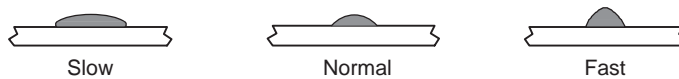

GUN TRAVEL SPEED

S-0634

8-5. Gun Movement During Welding

NOTE

Normally, a single stringer bead is satisfactory for most narrow groove weld joints; however, for wide groove weld joints or bridging across gaps, a weave bead or multiple stringer beads works better.

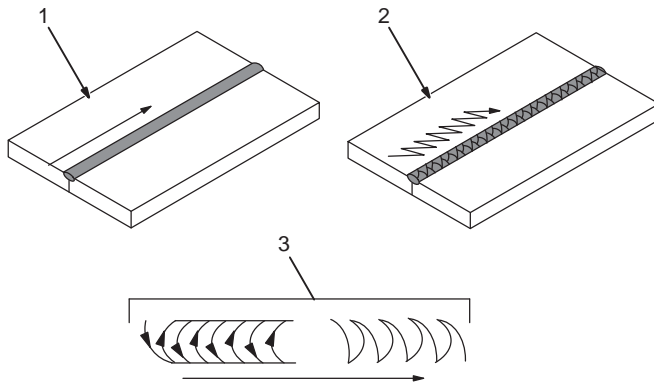

- 1 Stringer Bead – Steady Movement Along Seam
- 2 Weave Bead – Side To Side Movement Along Seam
- 3 Weave Patterns

Use weave patterns to cover a wide area in one pass of the electrode.

S-0054-A

8-6. Poor Weld Bead Characteristics

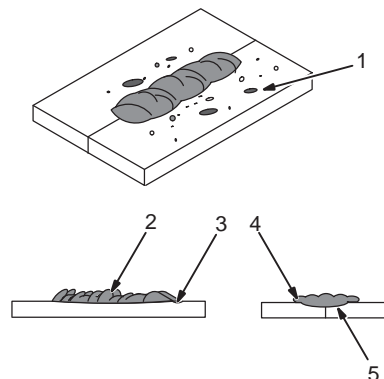

- 1 Large Spatter Deposits
- 2 Rough, Uneven Bead
- 3 Slight Crater During Welding
- 4 Bad Overlap
- 5 Poor Penetration

S-0053-A

8-7. Good Weld Bead Characteristics

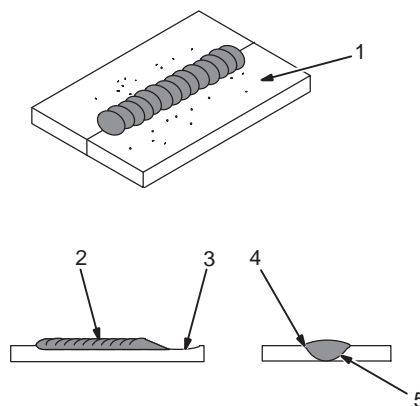

- 1 Fine Spatter
- 2 Uniform Bead
- 3 Moderate Crater During Welding

Weld a new bead or layer for each 1/8 in (3.2 mm) thickness in metals being welded.

- 4 No Overlap
- 5 Good Penetration into Base Metal

S-0052-B

8-8. Troubleshooting – Excessive Spatter

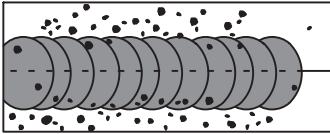

Excessive Spatter – scattering of molten metal particles that cool to solid form near weld bead.

S-0636

Possible Causes	Corrective Actions
Wire feed speed too high.	Select lower wire feed speed.
Voltage too high.	Select lower voltage range.
Electrode extension (stickout) too long.	Use shorter electrode extension (stickout).
Workpiece dirty.	Remove all grease, oil, moisture, rust, paint, undercoating, and dirt from work surface before welding.
Insufficient shielding gas at welding arc.	Increase flow of shielding gas at regulator/flowmeter and/or prevent drafts near welding arc.
Dirty welding wire.	Use clean, dry welding wire.
	Eliminate pickup of oil or lubricant on welding wire from feeder or liner.
Wrong polarity.	Configure polarity as shown in Section 4-5. Always read and follow wire manufacturer's recommended polarity, and see Section 4-5.

8-9. Troubleshooting – Porosity

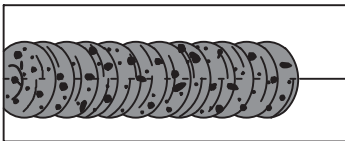

Porosity – small cavities or holes resulting from gas pockets in weld metal.

S-0635

Possible Causes	Corrective Actions
Insufficient shielding gas at welding arc.	Increase flow of shielding gas at regulator/flowmeter and/or prevent drafts near welding arc.
	Remove spatter from gun nozzle.
	Check gas hoses for leaks.
	Place nozzle 1/4 to 1/2 in (6-13 mm) from workpiece.
	Hold gun near bead at end of weld until molten metal solidifies.
Wrong gas.	Use welding grade shielding gas; change to different gas.
Dirty welding wire.	Use clean, dry welding wire.
	Eliminate pick up of oil or lubricant on welding wire from feeder or liner.
Workpiece dirty.	Remove all grease, oil, moisture, rust, paint, coatings, and dirt from work surface before welding.
	Use a more highly deoxidizing welding wire (contact supplier).
Welding wire extends too far out of nozzle.	Be sure welding wire extends not more than 1/2 in (13 mm) beyond nozzle.
Wrong polarity.	Configure polarity as shown in Section 4-5. Always read and follow wire manufacturer's recommended polarity, and see Section 4-5.

8-10. Troubleshooting – Excessive Penetration

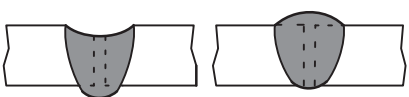
		<p>Excessive Penetration – weld metal melting through base metal and hanging underneath weld.</p>
		S-0639
Possible Causes	Corrective Actions	
Excessive heat input.	Select lower voltage range and reduce wire feed speed.	
	Increase travel speed.	
Wrong polarity.	Configure polarity as shown in Section 4-5. Always read and follow wire manufacturer's recommended polarity, and see Section 4-5.	

8-11. Troubleshooting – Lack Of Penetration

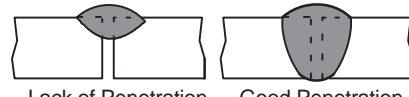
		<p>Lack Of Penetration – shallow fusion between weld metal and base metal.</p>
		S-0638
Possible Causes	Corrective Actions	
Improper joint preparation.	Material too thick. Joint preparation and design must provide access to bottom of groove while maintaining proper welding wire extension and arc characteristics.	
Improper weld technique.	Maintain normal gun angle of 0 to 15 degrees to achieve maximum penetration.	
	Keep arc on leading edge of weld puddle.	
	Be sure welding wire extends not more than 1/2 in (13 mm) beyond nozzle.	
Insufficient heat input.	Select higher wire feed speed and/or select higher voltage range.	
	Reduce travel speed.	
Wrong polarity.	Configure polarity as shown in Section 4-5. Always read and follow wire manufacturer's recommended polarity, and see Section 4-5.	

8-12. Troubleshooting – Incomplete Fusion

		<p>Incomplete Fusion – failure of weld metal to fuse completely with base metal or a preceding weld bead.</p>
		S-0637
Possible Causes	Corrective Actions	
Workpiece dirty.	Remove all grease, oil, moisture, rust, paint, undercoating, and dirt from work surface before welding.	
Insufficient heat input.	Select higher voltage range and/or adjust wire feed speed.	
Improper welding technique.	Place stringer bead in proper location(s) at joint during welding.	
	Adjust work angle or widen groove to access bottom during welding.	
	Momentarily hold arc on groove side walls when using weaving technique.	
	Keep arc on leading edge of weld puddle.	
	Use correct gun angle of 0 to 15 degrees.	
Wrong polarity.	Configure polarity as shown in Section 4-5. Always read and follow wire manufacturer's recommended polarity, and see Section 4-5.	

8-13. Troubleshooting – Burn-Through

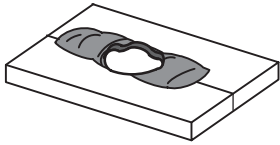

Burn-Through – weld metal melting completely through base metal resulting in holes where no metal remains.

S-0640

Possible Causes	Corrective Actions
Excessive heat input.	Select lower voltage range and reduce wire feed speed.
	Increase and/or maintain steady travel speed.
Wrong polarity.	Configure polarity as shown in Section 4-5. Always read and follow wire manufacturer's recommended polarity, and see Section 4-5.

8-14. Troubleshooting – Waviness Of Bead

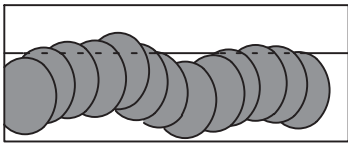

Waviness Of Bead – weld metal that is not parallel and does not cover joint formed by base metal.

S-0641

Possible Causes	Corrective Actions
Welding wire extends too far out of nozzle.	Be sure welding wire extends not more than 1/2 in (13 mm) beyond nozzle.
Unsteady hand.	Support hand on solid surface or use two hands.

8-15. Troubleshooting – Distortion

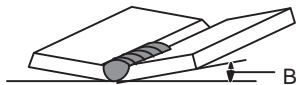

Base metal moves in the direction of the weld bead.

Distortion – contraction of weld metal during welding that forces base metal to move.

S-0642

Possible Causes	Corrective Actions
Excessive heat input.	Use restraint (clamp) to hold base metal in position.
	Make tack welds along joint before starting welding operation.
	Select lower voltage range and/or reduce wire feed speed.
	Increase travel speed.
	Weld in small segments and allow cooling between welds.

8-16. Common MIG Shielding Gases

This is a general chart for common gases and where they are used. Many different combinations (mixtures) of shielding gases have been developed over the years. The most commonly used shielding gases are listed in the following table.

Gas	Application			
	Spray Arc Steel	Short Circuiting Steel	Short Circuiting Stainless Steel	Short Circuiting Aluminum
Argon				All Positions
Argon + 25% CO ₂	Flat & Horizontal ¹ Fillet	All Positions	All Positions ²	
CO ₂	Flat & Horizontal ¹ Fillet	All Positions		
Tri-Mix ³			All Positions	

1 Globular Transfer

2 Single Pass Welding Only

3 90% HE + 7-1/2% AR + 2-1/2% CO₂

SECTION 9 – PARTS LIST

9-1. Recommended Spare Parts

Item No.	Part No.	Description	Quantity
.....	169 715	.. NOZZLE, slip type .500 orf flush	1
.....	◆087 299	.. TIP, contact scr .023 wire x 1.125	
.....	◆000 067	.. TIP, contact scr .030 wire x 1.125	
.....	◆000 068	.. TIP, contact scr .035 wire x 1.125	
.....	◆000 069	.. TIP, contact scr .045 wire x 1.125	
.....	◆194 010	.. LINER, monocoil .023/.025 wire x 15ft (consisting of)	1
.....	◆194 011	.. LINER, monocoil .030/.035 wire x 15ft (consisting of)	1
.....	◆194 012	.. LINER, monocoil .035/.045 wire x 15ft (consisting of)	1
.....	079 975 O-RING, .187 ID x .103CS rbr	1

◆OPTIONAL

To maintain the factory original performance of your equipment, use only **Manufacturer's Suggested Replacement Parts**. Model and serial number required when ordering parts from your local distributor.

9-2. Optional Drive Rolls

For All Feed Head Assemblies	
PART NO.	WIRE DIAMETER INCHES (mm)
220 179	.024 (.6) and .030 – .035 (.8 and .9)
202 926	.030/.035 (.8 and .9) and .045 (1.2 VK Groove)

9-3. Options

PART NO.	DESCRIPTION	REMARKS
770 187	Running Gear/Cylinder Rack	For One Small Gas Cylinder, 100 lb (45 kg)
194 776	Small Running Gear/Cylinder Rack	For One Small Gas Cylinder, 75 lb (34 kg)
195 605	M-10 Replacement Gun	10 ft length/.030-.035 wire size

☞ A complete Parts List is available on-line at www.MillerWelds.com

Notes

DECIMAL EQUIVALENTS

	$\frac{1}{64}$.015625
	$\frac{2}{64}$.03125
	$\frac{3}{64}$.046875
$\frac{1}{16}$	$\frac{4}{64}$.0625
	$\frac{5}{64}$.078125
	$\frac{6}{64}$.09375
	$\frac{7}{64}$.109375
$\frac{1}{8}$	$\frac{8}{64}$.125
	$\frac{9}{64}$.140625
	$\frac{10}{64}$.15625
	$\frac{11}{64}$.171875
$\frac{3}{16}$	$\frac{12}{64}$.1875
	$\frac{13}{64}$.203125
	$\frac{14}{64}$.21875
	$\frac{15}{64}$.234375
$\frac{1}{4}$	$\frac{16}{64}$.25
	$\frac{17}{64}$.265625
	$\frac{18}{64}$.28125
	$\frac{19}{64}$.296875
$\frac{5}{16}$	$\frac{20}{64}$.3125
	$\frac{21}{64}$.328125
	$\frac{22}{64}$.34375
	$\frac{23}{64}$.359375
$\frac{3}{8}$	$\frac{24}{64}$.375
	$\frac{25}{64}$.390625
	$\frac{26}{64}$.40625
	$\frac{27}{64}$.421875
$\frac{7}{16}$	$\frac{28}{64}$.4375
	$\frac{29}{64}$.453125
	$\frac{30}{64}$.46875
	$\frac{31}{64}$.484375
$\frac{1}{2}$	$\frac{32}{64}$.5
	$\frac{33}{64}$.515625
	$\frac{34}{64}$.53125
	$\frac{35}{64}$.546875
$\frac{9}{16}$	$\frac{36}{64}$.5625
	$\frac{37}{64}$.578125
	$\frac{38}{64}$.59375
	$\frac{39}{64}$.609375
$\frac{5}{8}$	$\frac{40}{64}$.625
	$\frac{41}{64}$.640625
	$\frac{42}{64}$.65625
	$\frac{43}{64}$.671875
$\frac{11}{16}$	$\frac{44}{64}$.6875
	$\frac{45}{64}$.703125
	$\frac{46}{64}$.71875
	$\frac{47}{64}$.734375
$\frac{3}{4}$	$\frac{48}{64}$.75
	$\frac{49}{64}$.765625
	$\frac{50}{64}$.78125
	$\frac{51}{64}$.796875
$\frac{13}{16}$	$\frac{52}{64}$.8125
	$\frac{53}{64}$.828125
	$\frac{54}{64}$.84375
	$\frac{55}{64}$.859375
$\frac{7}{8}$	$\frac{56}{64}$.875
	$\frac{57}{64}$.890625
	$\frac{58}{64}$.90625
	$\frac{59}{64}$.921875
$\frac{15}{16}$	$\frac{60}{64}$.9375
	$\frac{61}{64}$.953125
	$\frac{62}{64}$.96875
	$\frac{63}{64}$.984375
1		1.

TRUE BLUE[®]

WARRANTY

Effective January 1, 2007

(Equipment with a serial number preface of "LH" or newer)

This limited warranty supersedes all previous Miller warranties and is exclusive with no other guarantees or warranties expressed or implied.

LIMITED WARRANTY – Subject to the terms and conditions below, Miller Electric Mfg. Co., Appleton, Wisconsin, warrants to its original retail purchaser that new Miller equipment sold after the effective date of this limited warranty is free of defects in material and workmanship at the time it is shipped by Miller. THIS WARRANTY IS EXPRESSLY IN LIEU OF ALL OTHER WARRANTIES, EXPRESS OR IMPLIED, INCLUDING THE WARRANTIES OF MERCHANTABILITY AND FITNESS.

Within the warranty periods listed below, Miller will repair or replace any warranted parts or components that fail due to such defects in material or workmanship. Miller must be notified in writing within thirty (30) days of such defect or failure, at which time Miller will provide instructions on the warranty claim procedures to be followed.

Miller shall honor warranty claims on warranted equipment listed below in the event of such a failure within the warranty time periods. All warranty time periods start on the delivery date of the equipment to the original end-user purchaser, and not to exceed one year after the equipment is shipped to a North American distributor or eighteen months after the equipment is shipped to an International distributor.

1. 5 Years Parts — 3 Years Labor
 - * Original main power rectifiers
2. 3 Years — Parts and Labor
 - * Transformer/Rectifier Power Sources
 - * Plasma Arc Cutting Power Sources
 - * Process Controllers
 - * Semi-Automatic and Automatic Wire Feeders
 - * Inverter Power Sources (Unless Otherwise Stated)
 - * Water Coolant Systems (Integrated)
 - * Intelligig
 - * Engine Driven Welding Generators
(NOTE: Engines are warranted separately by the engine manufacturer.)
3. 1 Year — Parts and Labor Unless Specified
 - * Motor Driven Guns (w/exception of Spoolmate Spoolguns)
 - * Positioners and Controllers
 - * Automatic Motion Devices
 - * RFCS Foot Controls
 - * Induction Heating Power Sources, Coolers, and Electronic Controls/Recorders
 - * Water Coolant Systems (Non-Integrated)
 - * Flowgauge and Flowmeter Regulators (No Labor)
 - * HF Units
 - * Grids
 - * Spot Welders
 - * Load Banks
 - * Arc Stud Power Sources & Arc Stud Guns
 - * Racks
 - * Running Gear/Trailers
 - * Plasma Cutting Torches (except APT & SAF Models)
 - * Field Options
(NOTE: Field options are covered under True Blue[®] for the remaining warranty period of the product they are installed in, or for a minimum of one year — whichever is greater.)
 - * Bernard-Branded Mig Guns (No Labor)
 - * Weldcraft-Branded TIG Torches (No Labor)
 - * Subarc Wire Drive Assemblies
4. 6 Months — Batteries
5. 90 Days — Parts
 - * MIG Guns/TIG Torches and Subarc (SAW) Guns

- * Induction Heating Coils and Blankets, Cables, and Non-Electronic Controls
- * APT & SAF Model Plasma Cutting Torches
- * Remote Controls
- * Accessory (Kits)
- * Replacement Parts (No labor)
- * Spoolmate Spoolguns
- * Canvas Covers

Miller's True Blue[®] Limited Warranty shall not apply to:

1. **Consumable components; such as contact tips, cutting nozzles, contactors, brushes, slip rings, relays or parts that fail due to normal wear. (Exception: brushes, slip rings, and relays are covered on Bobcat, Trailblazer, and Legend models.)**
2. Items furnished by Miller, but manufactured by others, such as engines or trade accessories. These items are covered by the manufacturer's warranty, if any.
3. Equipment that has been modified by any party other than Miller, or equipment that has been improperly installed, improperly operated or misused based upon industry standards, or equipment which has not had reasonable and necessary maintenance, or equipment which has been used for operation outside of the specifications for the equipment.

MILLER PRODUCTS ARE INTENDED FOR PURCHASE AND USE BY COMMERCIAL/INDUSTRIAL USERS AND PERSONS TRAINED AND EXPERIENCED IN THE USE AND MAINTENANCE OF WELDING EQUIPMENT.

In the event of a warranty claim covered by this warranty, the exclusive remedies shall be, at Miller's option: (1) repair; or (2) replacement; or, where authorized in writing by Miller in appropriate cases, (3) the reasonable cost of repair or replacement at an authorized Miller service station; or (4) payment of or credit for the purchase price (less reasonable depreciation based upon actual use) upon return of the goods at customer's risk and expense. Miller's option of repair or replacement will be F.O.B., Factory at Appleton, Wisconsin, or F.O.B. at a Miller authorized service facility as determined by Miller. Therefore no compensation or reimbursement for transportation costs of any kind will be allowed.

TO THE EXTENT PERMITTED BY LAW, THE REMEDIES PROVIDED HEREIN ARE THE SOLE AND EXCLUSIVE REMEDIES. IN NO EVENT SHALL MILLER BE LIABLE FOR DIRECT, INDIRECT, SPECIAL, INCIDENTAL OR CONSEQUENTIAL DAMAGES (INCLUDING LOSS OF PROFIT), WHETHER BASED ON CONTRACT, TORT OR ANY OTHER LEGAL THEORY.

ANY EXPRESS WARRANTY NOT PROVIDED HEREIN AND ANY IMPLIED WARRANTY, GUARANTY OR REPRESENTATION AS TO PERFORMANCE, AND ANY REMEDY FOR BREACH OF CONTRACT TORT OR ANY OTHER LEGAL THEORY WHICH, BUT FOR THIS PROVISION, MIGHT ARISE BY IMPLICATION, OPERATION OF LAW, CUSTOM OF TRADE OR COURSE OF DEALING, INCLUDING ANY IMPLIED WARRANTY OF MERCHANTABILITY OR FITNESS FOR PARTICULAR PURPOSE, WITH RESPECT TO ANY AND ALL EQUIPMENT FURNISHED BY MILLER IS EXCLUDED AND DISCLAIMED BY MILLER.

Some states in the U.S.A. do not allow limitations of how long an implied warranty lasts, or the exclusion of incidental, indirect, special or consequential damages, so the above limitation or exclusion may not apply to you. This warranty provides specific legal rights, and other rights may be available, but may vary from state to state.

In Canada, legislation in some provinces provides for certain additional warranties or remedies other than as stated herein, and to the extent that they may not be waived, the limitations and exclusions set out above may not apply. This Limited Warranty provides specific legal rights, and other rights may be available, but may vary from province to province.

miller_warr 2007-01

Warranty Questions?

Call
1-800-4-A-MILLER
for your local
Miller distributor.

Your distributor also gives
you ...

Service

You always get the fast,
reliable response you
need. Most replacement
parts can be in your
hands in 24 hours.

Support

Need fast answers to the
tough welding questions?
Contact your distributor.
The expertise of the
distributor and Miller is
there to help you, every
step of the way.





Owner's Record

Please complete and retain with your personal records.

Model Name

Serial/Style Number

Purchase Date

(Date which equipment was delivered to original customer.)

Distributor

Address

City

State

Zip



For Service

Contact a **DISTRIBUTOR** or **SERVICE AGENCY** near you.

Always provide Model Name and Serial/Style Number.

Contact your Distributor for:

Welding Supplies and Consumables

Options and Accessories

Personal Safety Equipment

Service and Repair

Replacement Parts

Training (Schools, Videos, Books)

Technical Manuals (Servicing Information and Parts)

Circuit Diagrams

Welding Process Handbooks

To locate a Distributor or Service Agency visit www.millerwelds.com or call 1-800-4-A-Miller

Contact the Delivering Carrier to:

File a claim for loss or damage during shipment.

For assistance in filing or settling claims, contact your distributor and/or equipment manufacturer's Transportation Department.

Miller Electric Mfg. Co.

An Illinois Tool Works Company
1635 West Spencer Street
Appleton, WI 54914 USA

International Headquarters—USA

USA Phone: 920-735-4505 Auto-Attended
USA & Canada FAX: 920-735-4134
International FAX: 920-735-4125

European Headquarters – United Kingdom

Phone: 44 (0) 1204-593493
FAX: 44 (0) 1204-598066

www.MillerWelds.com

