



► FMM350QSL (\*\*) 7 229 ...

**FEIN Service**

**USA**

FEIN Power Tools, Inc.  
1000 Omega Drive  
Suite 1180  
Pittsburgh, PA 15205  
Telephone: (412) 922-8886  
Toll Free: 1-800-441-9878  
www.feinus.com

**Canada**

FEIN Canadian Power Tool  
Company  
323 Traders Boulevard East  
Mississauga, Ontario L4Z 2E5  
Telephone.: (905) 8901390  
Toll Free: 1-800-265-2581

FEIN Canadian Power Tool  
Company  
2810 De Miniac  
St. Laurent, Quebec H4S 1K9  
Telephone: (514) 331-7390  
Toll Free: 1-800-789-8181  
www.fein.com

**Headquarter**

C. & E. Fein GmbH  
Hans-Fein-Straße 81  
D-73529 Schwäbisch Gmünd-Bargau

**www.fein.com**

© C. & E. Fein GmbH. Printed in Germany. Figures non-binding. Subject to technical changes. 3 41 01 242 21 0 BY 2015.12 DE.

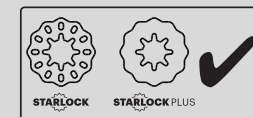
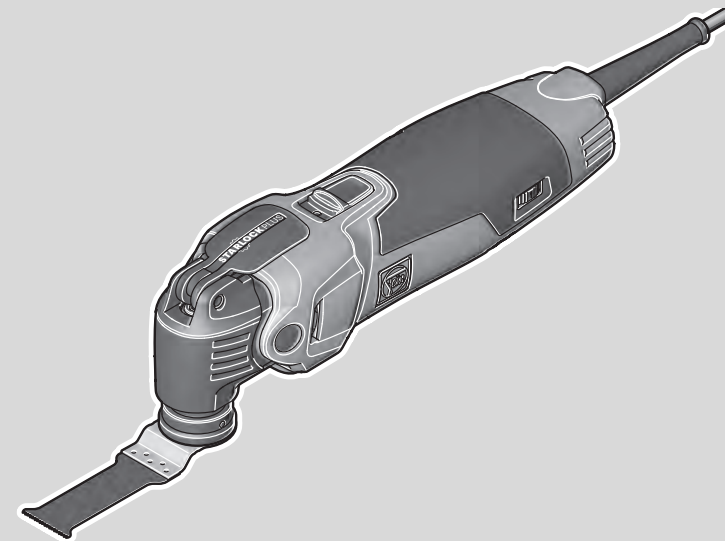



**en**

Instruction Manual

 3

**fr**

Mode d'emploi

 18

**es**

Instrucciones de uso

 34

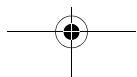
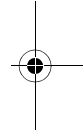
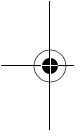

## For your safety.

**⚠ WARNING** **Read all safety warnings and all instructions.** Failure to follow the warnings and instructions may result in electric shock, fire and/or serious injury. **Save all warnings and instructions for future-reference.**

**🔒** Do not use this power tool before you have thoroughly read and completely understood this Instruction Manual, including the figures, specifications, safety regulations and the signs indicating DANGER, WARNING and CAUTION.

Only carry out such operations with this power tool as intended for by FEIN. Only use application tools and accessories that have been released by FEIN.

Please also observe the relevant national industrial safety regulations.

Non-observance of the safety instructions in the said documentation can lead to an electric shock, burns and/or severe injuries.

This Instruction Manual should be kept for later use and enclosed with the power tool, should it be passed on or sold.

**SAVE THESE INSTRUCTIONS.**

The term “power tool” in the warnings refers to your mains-operated (corded) power tool or battery operated (cordless) power tool.

## General safety rules.

### 1) Work area safety

**a) Keep work area clean and well lit.** Cluttered or dark areas invite accidents.

**b) Do not operate power tools in explosive atmospheres, such as in the presence of flammable liquids, gases or dust.** Power tools create sparks which may ignite the dust or fumes.

**c) Keep children and bystanders away while operating a power tool.** Distraction can cause you to lose control.

### 2) Electrical safety

**a) Power tool plugs must match the outlet. Never modify the plug in any way. Do not use any adapter plugs with earthed (grounded) power tools.** Unmodified plugs and matching outlets will reduce risk of electric shock.

**b) Avoid body contact with earthed or grounded surfaces such as pipes, radiators, ranges and refrigerators.** There is an increased risk of electric shock if your body is earthed or grounded.

**c) Do not expose power tools to rain or wet conditions.** Water entering a power tool will increase the risk of electric shock.

**d) Do not abuse the cord. Never use the cord for carrying, pulling or unplugging the power tool. Keep cord away from heat, oil, sharp edges or moving parts.** Damaged or entangled cords increase the risk of electric shock.

**e) When operating a power tool outdoors, use an extension cord suitable for outdoor use.** Use of a cord suitable for outdoor use reduces the risk of electric shock.

**f) If operating a power tool in a damp location is unavoidable, use a ground fault circuit interrupter (GFCI) protected supply.** Use of an GFCI reduces the risk of electric shock.

### 3) Personal safety

**a) Stay alert, watch what you are doing and use common sense when operating a power tool. Do not use a power tool while you are tired or under the influence of drugs, alcohol or medication.** A moment of inattention while operating power tools may result in serious personal injury.

**b) Use personal protective equipment. Always wear eye protection.** Protective equipment such as dust mask, non-skid safety shoes, hard hat, or hearing protection used for appropriate conditions will reduce personal injuries.

**c) Prevent unintentional starting. Ensure the switch is in the off-position before connecting to power source and/or battery pack, picking up or carrying the tool.** Carrying power tools with your finger on the switch or energising power tools that have the switch on invites accidents.

- d) **Remove any adjusting key or wrench before turning the power tool on.** A wrench or a key left attached to a rotating part of the power tool may result in personal injury.
  - e) **Do not overreach. Keep proper footing and balance at all times.** This enables better control of the power tool in unexpected situations.
  - f) **Dress properly. Do not wear loose clothing or jewelery. Keep your hair, clothing and gloves away from moving parts.** Loose clothes, jewelry or long hair can be caught in moving parts.
  - g) **If devices are provided for the connection of dust extraction and collection facilities, ensure these are connected and properly used.** Use of dust collection can reduce dust-related hazards.
- 4) **Power tool use and care**
- a) **Do not force the power tool. Use the correct power tool for your application.** The correct power tool will do the job better and safer at the rate for which it was designed.
  - b) **Do not use the power tool if the switch does not turn it on and off.** Any power tool that cannot be controlled with the switch is dangerous and must be repaired.
  - c) **Disconnect the plug from the power source and/or the battery pack from the power tool before making any adjustments, changing accessories, or storing power tools.** Such preventive safety measures reduce the risk of starting the power tool accidentally.
- d) **Store idle power tools out of the reach of children and do not allow persons unfamiliar with the power tool or these instructions to operate the power tool.** Power tools are dangerous in the hands of untrained users.
  - e) **Maintain power tools. Check for misalignment or binding of moving parts, breakage of parts and any other condition that may affect the power tool's operation. If damaged, have the power tool repaired before use.** Many accidents are caused by poorly maintained power tools.
  - f) **Keep cutting tools sharp and clean.** Properly maintained cutting tools with sharp cutting edges are less likely to bind and are easier to control.
  - g) **Use the power tool, accessories and tool bits etc. in accordance with these instructions, taking into account the working conditions and the work to be performed.** Use of the power tool for operations different from those intended could result in a hazardous situation.
- 5) **Service**
- a) **Have your power tool serviced by a qualified repair person using only identical replacement parts.** This will ensure that the safety of the power tool is maintained.

## Special safety instructions.

**Hold power tool by insulated gripping surfaces when performing an operation where the cutting accessory may contact hidden wiring or its own cord.** Cutting accessory contacting a "live" wire will make exposed metal parts of the power tool "live" and shock the operator.

**Use clamps or another practical method to secure and support the work piece on a stable surface.** When holding the work piece only by hand or against your body, it remains in an unstable position, which can lead to loss of control.

**Do not use accessories which are not specifically designed and recommended by the power tool manufacturer.** Safe operation is not ensured merely because an accessory fits your power tool.

**Grasp/hold the power tool in such a safe manner that your body never comes in contact with the application tool, particularly when working with application tools pointing toward the gripping area, such as with saw blades or cutting tools.** Touching sharp cutting edges or edges can lead to injury.

**Wear personal protective equipment. Depending on application, use face shield, safety goggles or safety glasses. Where appropriate, wear dust mask, hearing protectors, gloves and workshop apron capable of stopping small abrasive or workpiece fragments.** The safety glasses must be capable of protecting against flying particles generated by the various operations. Prolonged exposure to high intensity noise may cause loss of hearing.

**Do not direct the power tool against yourself, other persons or animals.** Danger of injury from sharp or hot application tools.

### Handling hazardous dusts.

**⚠ WARNING** When working with power tools, such as when grinding, sanding, polishing, sawing or for other work procedures where material is removed, dusts develop that are both hazardous to one's health and can spontaneously combust or be explosive.

Contact with or inhaling some dust types can trigger allergic reactions to the operator or bystanders and/or lead to respiratory infections, cancer, birth defects or other reproductive harm.

Examples of such materials which contain chemicals that can produce hazardous dusts, are:

- Asbestos and materials containing asbestos;
- Lead-containing coatings, some wood types such as beech and oak;
- Minerals and metal;
- Silicate particles from bricks, concrete and other materials containing stone;
- Solvent from solvent-containing paint/varnish;
- Arsenic, chromium and other wood preservatives;
- Materials for pesticide treatment on boat and ship hulls;
- Stainless steel dust, metal dust and non-ferrous metal dust;

**Do not rivet or screw any name-plates or signs onto the power tool.** If the insulation is damaged, protection against an electric shock will be ineffective. Adhesive labels are recommended.

**Clean the ventilation openings on the power tool at regular intervals using non-metal tools.** The blower of the motor draws dust into the housing. An excessive accumulation of metallic dust can cause an electrical hazard.

**Before putting into operation, check the power connection and the power plug for damage.**

**Recommendation: The tool should always be supplied with power via a ground fault circuit interrupter (GFCI) with a rated current of 30 mA or less.**

To minimize the unwanted intake of these materials:

- Use dust extraction matched appropriately for the developing dust.
- Use personal protective equipment, such as a P2 filter-class dust protection mask.
- Provide for good ventilation of the workplace.

The risk from inhaling dusts depends on how often these materials are worked. Materials containing asbestos may only be worked on by specialists.

**⚠ CAUTION** Wood and light-metal dust can cause spontaneous combustion or explosions.

Hot mixtures of sanding dust and paint/varnish remainders or other chemical materials in the filter bag or the vac filter can self-ignite under unfavorable conditions, such as sparking from sanding metal, continuous sunlight or high ambient temperatures. To prevent this:

- Avoid overheating the material being sanded and the power tool.
- Empty the dust collector/container in time.
- Observe the material manufacturer's working instructions.
- Observe the relevant regulations in your country for the materials being worked.

### Hand/arm vibrations.

**⚠ WARNING** While working with this power tool, hand/arm vibrations occur. These can lead to health impairments.

**⚠ WARNING** The vibration emission value during actual use of the power tool can differ from the declared value depending on the ways in which the tool is used.

**⚠ WARNING** It is necessary to identify safety measures to protect the operator that are based on an estimation of exposure in the actual conditions of use.

The vibration emission level given in this information sheet has been measured in accordance with a standardised test given in EN 60745 and may be used to compare one tool with another. It may be used for a preliminary assessment of exposure.

The declared vibration emission level represents the main applications of the tool. However if the tool is used for different applications, with different accessories or poorly maintained, the vibration emission may differ. This may significantly increase the exposure level over the total working period. An estimation of the level of exposure to vibration should also take into account the times when the tool is switched off or when it is running but not actually doing the job. This may significantly reduce the exposure level over the total working period. Identify additional safety measures to protect the operator from the effects of vibration such as: maintain the tool and the accessories, keep the hands warm, organisation of work patterns.

### Emission values for sound and vibration (Two-figure – specifications as per ISO 4871)

#### Sound emission

#### FMM350QSL (\*\*)

A-weighted emission pressure power level measured at the workplace $L_{pA}$ (re 20 $\mu\text{Pa}$ ), in decibels	72
Measuring uncertainty $K_{pA}$ , in decibels	3
Measured A-weighted sound power level $L_{wA}$ (re 1 pW), in decibels	83
Measuring uncertainty $K_{wA}$ , in decibels	3
C-weighted peak sound pressure level measured at the workplace $L_{pCpeak}$ in decibels	84
Measuring uncertainty $K_{pCpeak}$ in decibels	3

REMARK: The sum of the measured emission value and respective measuring inaccuracy represents the upper limit of the values that can occur during measuring.

 Wear hearing protection!

Measured values determined in accordance with the corresponding product standard.

Vibration	<i>a</i> Weighted acceleration*
Classification of FEIN application tools according to vibration class	
<i>VC0</i>	< 2.5 m/s <sup>2</sup> < 8 ft/s <sup>2</sup>
<i>VC1</i>	< 5 m/s <sup>2</sup> < 16 ft/s <sup>2</sup>
<i>VC2</i>	< 7 m/s <sup>2</sup> < 23 ft/s <sup>2</sup>
<i>VC3</i>	< 10 m/s <sup>2</sup> < 33 ft/s <sup>2</sup>

\* These values are based on a work cycle consisting of no-load and full-load operation of the same duration.  
For information on the vibration class assigned to the application tool, please refer to the enclosed data sheet 3 41 30 443 06 0.

Vibration	<i>a</i>
<i>VC4</i>	< 15 m/s <sup>2</sup> < 50 ft/s <sup>2</sup>
<i>VC5</i>	> 15 m/s <sup>2</sup> > 50 ft/s <sup>2</sup>
<i>Ka</i>	1.5 m/s <sup>2</sup> 4.92 ft/s <sup>2</sup>

\* These values are based on a work cycle consisting of no-load and full-load operation of the same duration.  
For information on the vibration class assigned to the application tool, please refer to the enclosed data sheet 3 41 30 443 06 0.

### Extension cable.

**⚠ WARNING** If the use of an extension cord is required, its length and conductor cross-section must be adequate for the application in order to prevent a voltage drop in the extension cord, power loss and overheating of the power tool. Otherwise, the extension cable and power tool are prone to electrical danger, and the working efficiency is decreased.

**Recommended dimensions of extension cords at an operating voltage of 120 V – single-phase a. c., with only FMM350QSL (\*\*\*) connected:**

Max. cable length, ft			Max. cable length, m		
≤ 100	100 –200	200 –300	≤ 30	30 – 60	60 –100
Min. conductor size A.W.G.			Min. conductor cross-section, mm <sup>2</sup>		
16	14	12	1.5	2.5	4

### Intended use of the power tool:















Hand-guided oscillator for sanding small surfaces, corners and edges, for sawing thin parts of steel sheet, wood and plastic, for scraping, polishing, rasping, cutting and separating without water in weather-protected environments, using the application tools and accessories recommended by FEIN.

## Operation of the power tool off power generators.



**!** This power tool is also suitable for use with AC generators with sufficient power output that correspond to the Standard ISO 8528, design type G2. This Standard is particularly not complied with when the so-called distortion factor exceeds 10 %. When in doubt, please refer to the generator instruction/specification guide.

**⚠ WARNING** Operating the power tool off power generators whose no-load speed exceeds the voltage value on the type plate of the power tool is prohibited.

## Symbols.

Symbol, character	Explanation
	Observe the instructions in the text or graphic opposite!
	General prohibition sign. This action is prohibited.
	Make sure to read the enclosed documents such as the Instruction Manual and the General Safety Instructions.
	Do not touch the saw blade. Danger of sharp application tools moving back and forth.
	Warning against sharp edges of application tools, such as the cutting edges of the cutter blades.
	Before commencing this working step, pull the power plug out of the socket. Otherwise there will be danger of injury if the power tool should start unintentionally.
	Use eye protection during operation.
	Wear hearing protection while working.
	Use a dust mask during operation.
	Use protective gloves during operation.
	Observe the notes in the text aside!
	This symbol confirms the certification of this product for the USA and Canada.
	This sign warns of a directly imminent, dangerous situation. A false reaction can cause a severe or fatal injury.
	This sign indicates a possible dangerous situation that could cause severe or fatal injury.
	This sign warns of a possible dangerous situation that could cause injury.



Symbol, character	Explanation
	Worn out power tools and other electrotechnical and electrical products should be sorted separately for environmentally-friendly recycling.
	Product with double or reinforced insulation
~ or a. c.	Alternating current
1 ~	Alternating current, single-phase

Character	Unit of measurement, national	Explanation
$n_0$	rpm; /min; $\text{min}^{-1}$ ; r/min	Rated oscillation rate
$P$	W	Electrical power
	°	Oscillation angle
$U$	V	Electric voltage
$f$	Hz	Frequency
$I$	A	Electric current intensity
$m$	lbs	Mass
$l$	ft, in	Length, width, height, depth, diameter or thread
$\varnothing$	ft, in	Diameter of a round part
$K...$		Uncertainty
$a$	$\text{m/s}^2$	Vibrational emission value according to EN 60745 (vector sum of three directions)
	m, s, kg, A, mm, V, W, Hz, N, °C, dB, min, $\text{m/s}^2$	Basic and derived units of measurement from the international system of units <b>SI</b> .

## Technical description and specifications.

**⚠ WARNING** Before mounting or replacing cutting tool or accessories, pull the power plug. This preventive safety measure rules out the danger of injuries through accidental starting of the power tool.

All accessories described or shown in this instruction manual will not be included with your power tool.

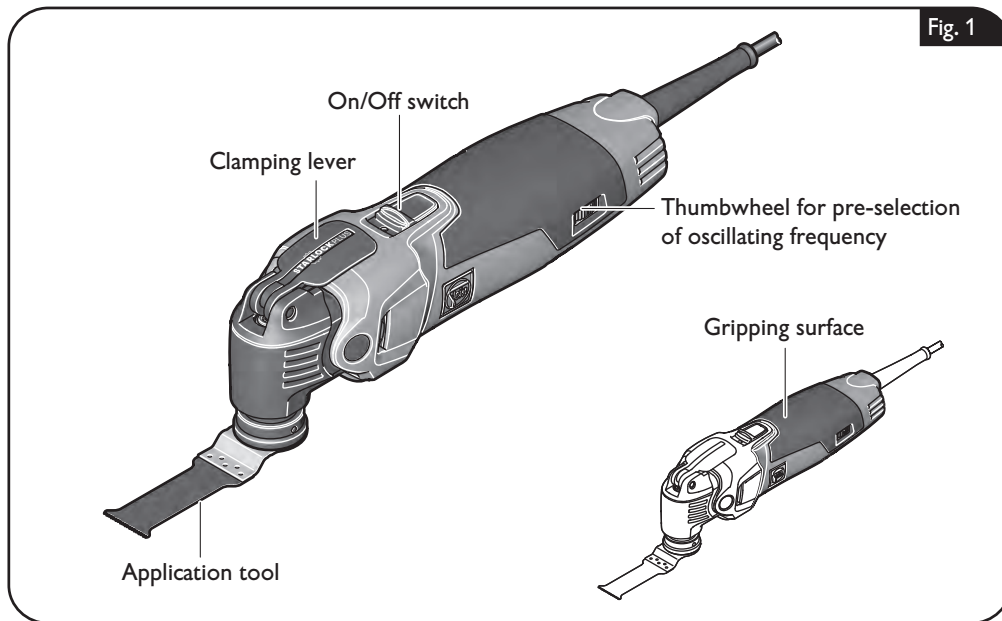

Fig. 1

<b>Type</b>	<b>FMM350QSL (**)</b>
Order number	7 229 ...
Current consumption	3.6 A
Rated oscillation rate	10000 – 19500 /min
Amplitude	2 x 1.7°
Weight according to EPTA-Procedure 01	3.2 lbs (1.45 kg)
Class of protection	□/II

## Assembly instructions.

**⚠ WARNING** Before mounting or replacing cutting tool or accessories, pull the power plug. This preventive safety measure rules out the danger of injuries through accidental starting of the power tool.

**Mounting the depth stop (figure 2).**  
Mount the depth stop with the 2 screws to the bottom side of the gear case.

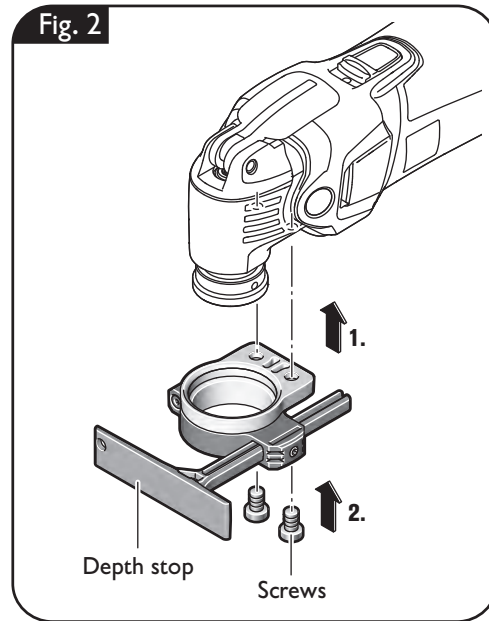

## Assembly instructions.

**⚠ WARNING** Before mounting or replacing cutting tool or accessories, pull the power plug. This preventive safety measure rules out the danger of injuries through accidental starting of the power tool.

**⚠ CAUTION** For all work or when changing application tools, always wear protective gloves. Danger of injury from the sharp edges of the application tools. Application tools can become very hot while working. Danger of burns!

### Changing the tool.

**⚠ CAUTION** Do not switch the power tool on while the clamping lever is open. Otherwise there is danger of crushes or contusions to the hand and fingers.

**⚠ CAUTION** Do not actuate the clamping lever while the power tool is running. Otherwise there is danger of injury.

**⚠ CAUTION** Do not reach into the area of the clamping jaws. Otherwise there is danger of crushes or contusions to the fingers.

**⚠ CAUTION** Do not operate the power tool with open clamping jaws and without an application tool! This could damage the power tool.

**⚠ CAUTION** When the clamping jaws are open before the application tool is inserted, pivot the clamping lever toward the front and then back again. The clamping jaws are closed now. The application tool can be inserted.

### Inserting the application tool (figure 3).

Clean the tool holder and the application tool. In the starting position, the clamping jaws in the tool holder are together. In this position, the application tool can be clipped-in easily.

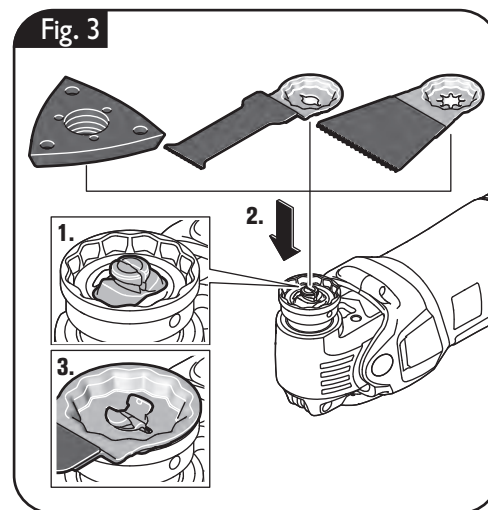

**Positioning the tool (figure 4).**

The application tool can be offset in 30° steps and fastened in the most favorable working position.

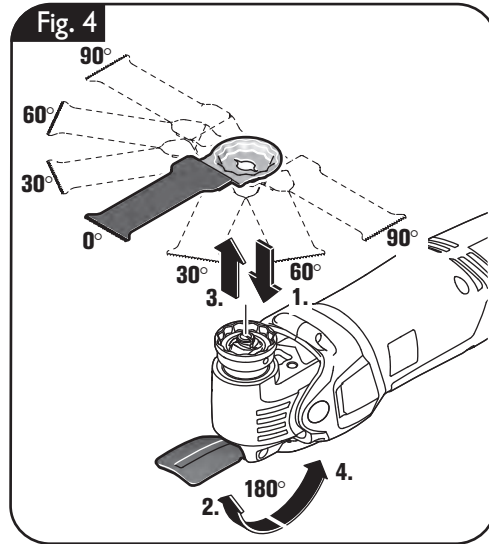
**Ejecting the application tool (figure 5).**

To eject the application tool and have the starting position set, move the clamping lever back to the stop; in this, the application tool is also released.

Pay attention that the application tool is seated straightly the tool holder.

**⚠ For all work or when changing application tools, always wear protective gloves.**

Danger of injury from the sharp edges of the application tools. Application tools can become very hot while working. Danger of burns!

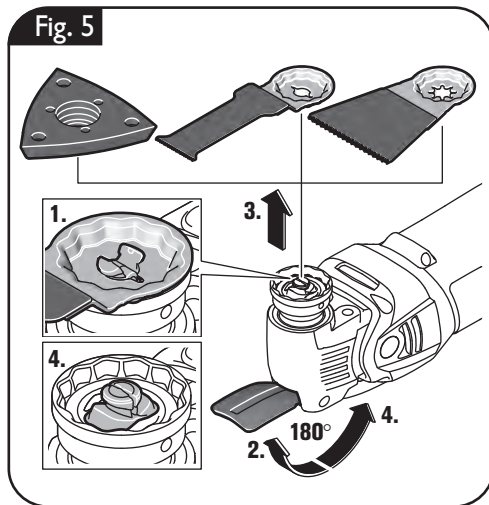

**Dust extraction (figure 6).**

Mount the dust extraction.  
Afterwards, mount the desired sanding sheet.  
Connect a vacuum cleaner.

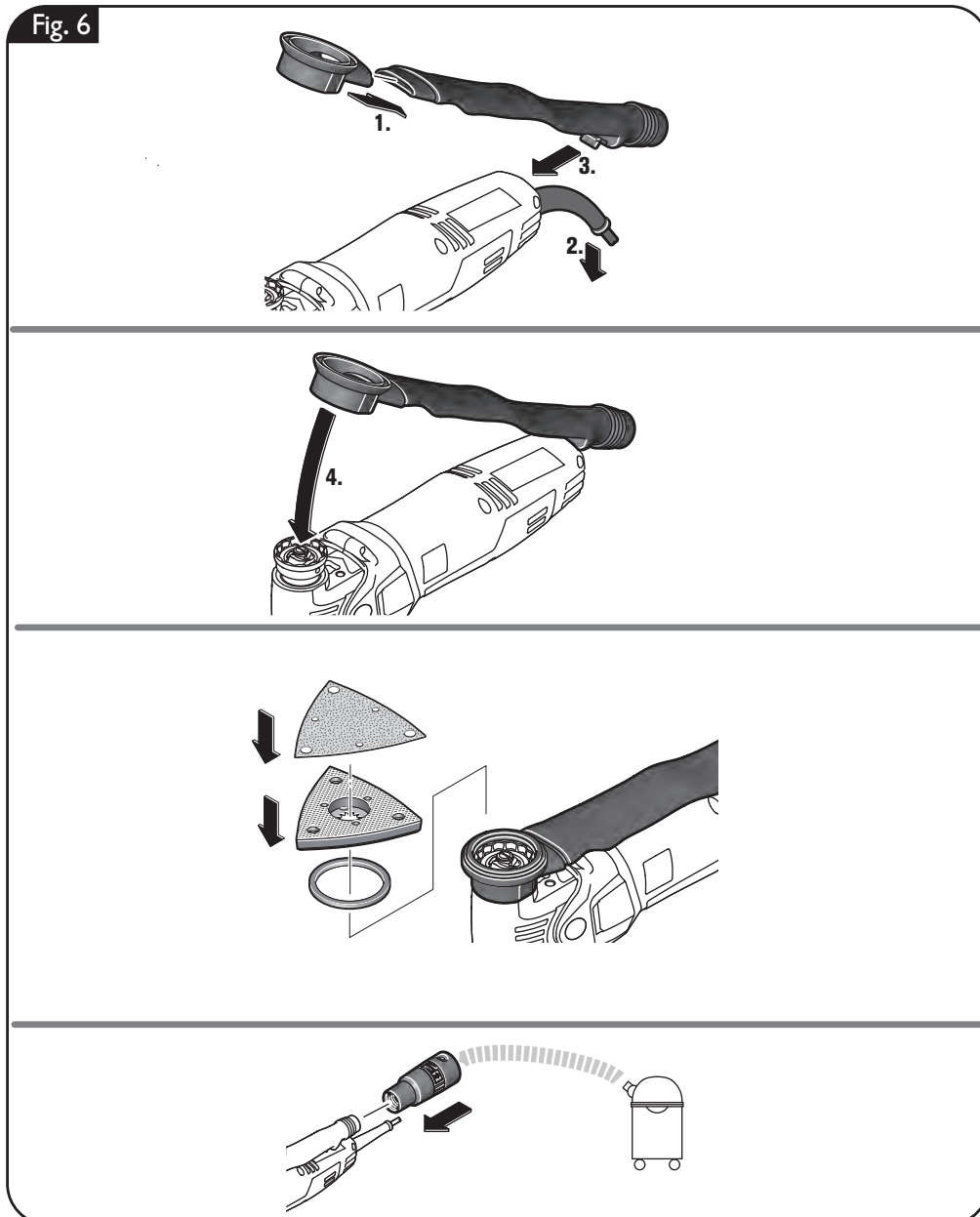

## Working instructions.

**⚠ WARNING** Before mounting or replacing cutting tool or accessories, pull the power plug. This preventive safety measure rules out the danger of injuries through accidental starting of the power tool.

**Do not use accessories not specifically intended and recommended for this power tool by FEIN.** The use of non-original FEIN accessories can lead to overheating of the power tool and destroy it.

**⚠ CAUTION** For each job, use only the FEIN application tool released and intended for the respective application.

### Switching on and off (figure 7).

**⚠ CAUTION** Always hold the power tool firmly. Otherwise, you could lose control over the power tool.

**👉 Guide the power tool toward the work piece only when switched on.**

#### Switching on:

Push the switch toward the front (I).

#### Switching off:

Push the switch toward the rear (O).

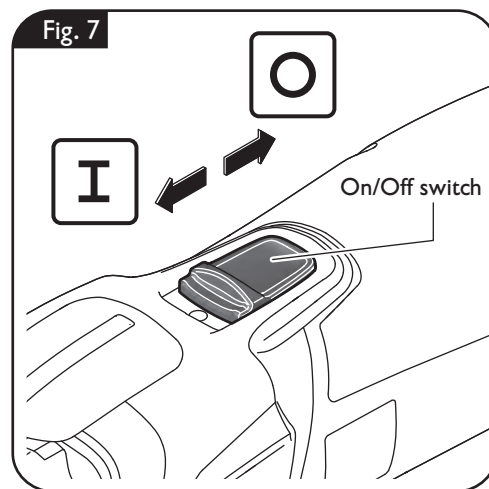

### Setting the oscillating frequency (figure 8).

Adjust the oscillating frequency infinitely variable with the dial control.

Turn the dial control between "1" for the lowest speed and "6" for the highest speed.

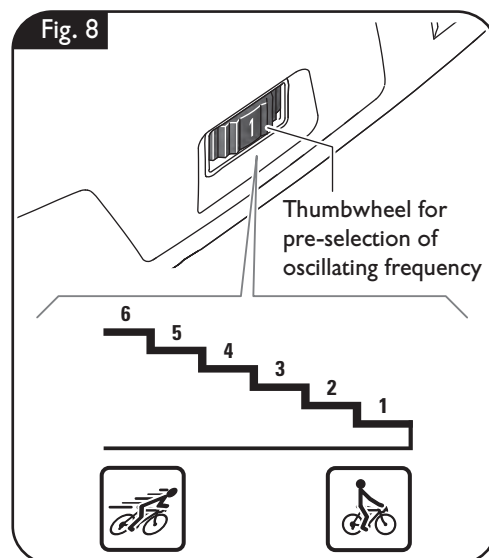



### **Notes on sanding.**

Press the power tool with the sanding sheet briefly and firmly against a flat surface and briefly switch the power tool on. This provides for good adhesion and prevents premature wear.

When only one tip or corner of the sanding sheet is worn, it can be removed again and reattached, turned by 120°.

Work with the entire surface of the sanding plate, not only with the tip.

When sanding with small triangle sanding plates, select a high oscillating frequency (electronics level 4 – 6); when sanding with the round sanding plate and the large triangle sanding plate, select a moderate oscillating frequency (max. electronics level 4).

Sand with continuous motion applying moderate pressure. Applying excessive pressure does not increase the rate of removal, it only wears off the sanding sheet faster.

### **Notes on profile sanding.**

Select a medium oscillating frequency.

### **Notes on sawing.**

Select a high oscillating frequency. Round saw blades can be released and clamped offset again, to allow for uniform wearing off.

### **Notes on scraping.**

Select a moderate to high oscillating frequency.





## Repair and customer service.

**⚠ WARNING** Before mounting or replacing cutting tool or accessories, pull the power plug. This preventive safety measure rules out the danger of injuries through accidental starting of the power tool.

### Exchangeable parts

If required, you can change the following parts yourself:

Application tools

### Service.

**⚠ WARNING** Have maintenance carried out only through qualified personnel. Incorrectly mounted leads and components can cause serious injuries. Have the required service carried out only through a FEIN customer service agent.

The current spare parts list for this power tool can be found in the Internet at [www.fein.com](http://www.fein.com).

### Cleaning.

**⚠ WARNING** Prior to any cleaning or maintenance, disconnect the power tool from the power supply in order to avoid accidents.

**⚠ WARNING** When using in environments with conductive dust in the air, such as when cutting metals, this dust can settle in the interior of the power tool.

This can impair the total insulation of the power tool. Therefore, regularly blow out the interior of the power tool from outside via the ventilation openings with dry, oil-free compressed air; always wear eye protection when doing this. For additional protection, connect a ground fault circuit interrupter (GFCI) on the line side.

**⚠ CAUTION** Do not attempt to clean clogged or dirty ventilation openings of the power tool with pointed metal objects; use nonmetal tools or objects if necessary.

**⚠ CAUTION** Do not use cleaning agents and solvents that can cause damage to plastic parts. These include: Gasoline, carbon-tetrachloride, chloric solvents, ammonia and domestic cleaning agents that contain ammonia.

**⚠ CAUTION** If the supply cable of this power tool is damaged, it must be replaced by a specially prepared cable available through the FEIN customer service center.

## Warranty and liability.

The warranty for the product is valid in accordance with the legal regulations in the country where it is marketed. In addition, FEIN also provides a guarantee in accordance with the FEIN manufacturer's warranty declaration.

All accessories described or shown in this instruction manual will not be included with your power tool.

## Environmental protection, disposal.

Packaging, worn out power tools and accessories should be sorted for environmental-friendly recycling.