



# ELECTRIC POWERED CARTS

OWNER'S MANUAL



FOR USE WITH ALL CARTS AND WHEELBARROWS  
WITH 35 & 39 AMP HR BATTERY PACKS

97011-6.2

## CONTENTS

CART FEATURES .....	3
FREQUENTLY ASKED QUESTIONS .....	4
CHARGING INFORMATION.....	5
OPERATING INSTRUCTIONS.....	6
TROUBLESHOOTING .....	7
BATTERY INFORMATION .....	8
<b>4WD CARTS.....</b>	<b>9</b>
OPERATING INSTRUCTIONS .....	10
USING THE HOPPER.....	11
BATTERY REPLACEMENT .....	12
PARTS DIAGRAM .....	15
WIRING DIAGRAM 4WD W/ POWER DUMP .....	17
WIRING DIAGRAM 4WD W/O POWER DUMP .....	18
<b>RIDE ON CARTS .....</b>	<b>19</b>
DRIVING YOUR CART .....	20
USING THE HOPPER.....	20
BATTERY REPLACEMENT .....	21
PARTS DIAGRAM .....	24
WIRING DIAGRAM.....	25
ADDITIONAL REPLACEMENT PARTS.....	26

## MADE IN THE USA GUARANTEE



Our American made products are engineered, manufactured and assembled in Archbold, OH using USA made steel.



*Expect more. get more.*  
FROM GRANITE INDUSTRIES

- Exceptional quality and service on every single product.
- Professional grade designs by our in house engineers.
- Industry leading warranties.
- Family owned and operated in the USA.

To view more products from Overland Carts scan the QR code with your phone or visit [OverlandCarts.com](http://OverlandCarts.com)



## 1 YEAR WARRANTY

- **Electronics:** Includes controller, s-drive, and wiring
- **Powertrain:** Includes transaxle containing the motor and differential
- **Wheels, Casters & Tires**
- **Batteries & Charger**
- **Hoppers:** Includes Brentwood hopper, and white garden hopper

## 3 YEAR WARRANTY

- **Chassis:** Includes steel frame and powder coating

## TERMS

Warranty starts from the delivery date of the cart.

We will repair, without charge, any defect due to faulty material or workmanship. These warranties do not cover failures due to abuse, misuse, improper installation, accidental damage or when repairs or modifications have been made or attempted to be made by anyone other than Granite Industries. Any defective products that meet warranty specifications and Granite Industries approval, may be returned to the factory to be repaired or replaced free of charge. (Granite Industries will pay to ship replacement item(s) to the customer; however the customer is responsible for shipment of products to the factory.)

This remedy is the sole remedy in contract, tort or otherwise, and Granite Industries is not liable for incidental, consequential or special damages.

These warranties give you specific legal rights, and you may have other rights which vary from state to state.

Should you have any questions, contact Granite Industries at 877-447-2648. (Proof of purchase may be required).

Overland Carts are covered by one or more of the following patents:

US D752,834 S	US D752,838 S	US D779,762 S
US D752,835 S	US D752,307 S	US D779,765 S
US D752,836 S	US D752,308 S	US D781,020 S
US D752,837 S		

Overland carts are a part of the Granite Industries family. All carts are manufactured by Granite Industries in Archbold, Ohio.



**GRANITE  
INDUSTRIES**

**Customer Service**

**877-447-2648**

**M-F, 8am - 5pm EST**

# CART FEATURES

## Built with you in mind.

### Our carts come fully assembled

All Overland Carts come fully assembled, charged and ready to use. All you have to do is power the cart on and drive away. (We do recommend charging overnight after receiving.)

### Crate Disassembly Instructions:

We recommend using a drill or an electric screwdriver with a #2 Phillips bit or a #2 square bit to remove the screws. We recommend using a hammer or crowbar to remove the portions that are nailed down.

### We designed our carts to be simple to operate:

- To turn on, pull the red On/Off switch out towards you.
- Toggle the black switch for forward and reverse.
- Grasp and twist the throttle.
- To turn the cart off, simply push the red button in.

### Safety Features

- **Emergency Stop** – The red E-Stop button allows the user to immediately stop the progress of the cart.
- **AutoLock** – Automatically locks the wheels when the throttle is not being applied. This feature prevents the cart from rolling away from the user and also provides easy loading and unloading on inclines.
- **HillSense** – Allows the cart to be used safely on inclines and declines. The cart will travel at the speed set by the user, not by the incline or decline.
- **SmoothStart** – On acceleration, power is applied to the drive tires in a controlled manner ensuring a smooth start each time.
- **Four Wheel Design** – All Overland Carts have at least four wheels to provide maximum stability.

### They've been tested (again and again)

The standard 35 and 39 amp-hr rechargeable battery packs have been extensively tested. We are confident to rate the batteries with a 4-6 hour real world capacity. The cart was tested with three different weights (0 lbs, 300 lbs, 600 lbs) and driven on both grass and pavement.



## Satisfaction Guaranteed

Granite Industries is committed to making sure each Overland Cart meets your expectations. To ensure customer satisfaction, we offer a 15 day money back guarantee. Use the cart and see how much easier the cart makes your projects. If you're not satisfied, simply contact Granite Industries at 877-447-2648 for a return authorization and details.

Orders and quote requests can be emailed to [support@graniteind.com](mailto:support@graniteind.com) or faxed to 419-445-3304



## FREQUENTLY ASKED QUESTIONS

### **How long do the batteries last on a single charge?**

It is completely dependent upon how much weight is being carried, the type of terrain, and the softness or hardness of the surface. We estimate a range of 4-6 hours of "real world" use. PLEASE NOTE: Most use is not as intense as our "real world" estimates, so actual use time is typically much longer. Visit [YouTube.com/OverlandCarts](https://www.youtube.com/OverlandCarts) to view videos of our product testing.

### **When and how long should I charge my cart?**

Charge your cart immediately after using. If, during operation, the battery indicator light goes to red, it is time to recharge. It is recommended to leave the cart on the charger overnight to extend the life of the batteries.

### **How long will the batteries last before needing to be replaced?**

The batteries are designed to last for 300-500 charge/discharge cycles, which translate into approximately 1-2 years. The batteries are common and can be purchased from Granite, your local battery supplier, or on Amazon.

### **Will tipping the unit hurt the batteries, electronics, or drive system?**

No. Batteries, electronics, and drives can operate in any orientation.

### **What is the maximum speed?**

All Overland Carts operate from 0 to 3 miles per hour in both forward and reverse.

### **While pushing my cart in manual/freewheel mode, it suddenly decelerates aggressively. What causes this?**

There is a safety feature on your Overland Cart that is designed to prevent the cart from running away when the brake is manually disengaged.

### **How much weight can my cart handle?**

750 lbs is the maximum load for level ground.

### **Why does my cart lose traction when one wheel is off the ground?**

The drive system is an open differential that allows the machine to efficiently make turns without skidding the tires. The drawback is that if one of the drive tires leaves the ground, it will simply spin until all tires are back on the ground.

### **Is a balanced load important to the performance?**

Yes. Balancing the load so that it is not top-heavy or side-loaded, will allow much safer operation. Furthermore, most of the load should be located over top of the drive wheels for better traction.

### **How do I clean my Overland Cart?**

Simply remove all debris, hose it down with soapy water, and towel dry. We do not recommend using a pressure washer.

### **Can I use my Overland Cart in cold temperatures?**

You certainly can, but we recommend that you charge and store the batteries at room temperature.

### **What maintenance is required?**

Not much, really! Simply remember to always recharge when not in use - it's okay to leave the cart on the charger. The drive system is sealed for life, thus no lubrication is required. Also, keep the unit dry to enhance its life and appearance.

### **How should I store my cart?**

We recommend keeping your cart indoors, out of the rain and other elements. For long-term or "off season" storage, give the battery an overnight charge, then disconnect the battery pack from the cart and store it indoors at room temperature. Every 3-4 months, fully charge the battery even though it's not in use. This helps to prolong the life of the batteries.

### **Where is the serial number?**

Every Overland Cart comes with its own serial number. On the 4WD Carts, this is located on the front side of the upper control box. On the ride on carts, you will find it on the panel below the control box, right in front of your knees, if you're standing on the cart.

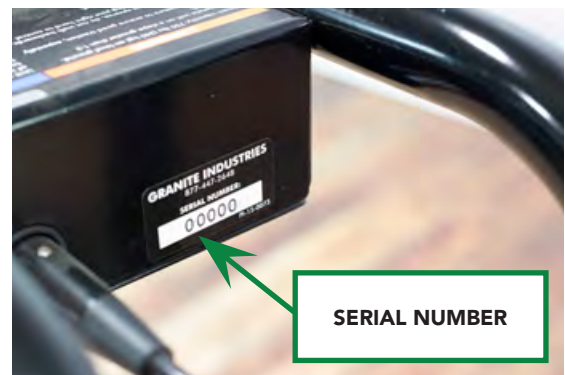

## FREQUENTLY ASKED QUESTIONS

### How do I identify the right and left tires?

Our ag tires have a specific tread pattern and if you ever need to replace a tire, you need to identify them as right or left. To do so, stand in front of your cart, so you are looking at the hopper. The left tire will be on your left side.



## CHARGING INFORMATION

### CHARGE YOUR CART

When your cart arrives, please plug it in and make sure the battery is fully charged. When charging, the indicator light will be orange. Once it reaches a full charge, the light will turn green, and your cart is ready to use.

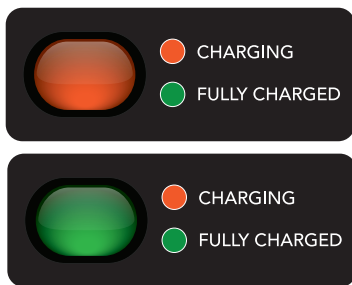

**NOTICE:** The charging indicator light is not present on ride-on carts. Use the battery indicator lights to determine amount of battery charge.

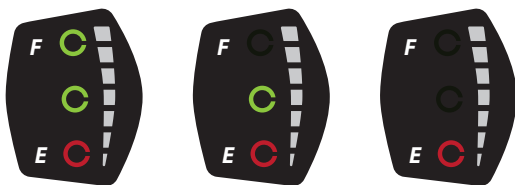

The charger can be left connected to the batteries after a full charge (green light) without harming the batteries. It uses a four stage charging system to optimize battery longevity. The charger uses minimum power in standby mode and maintains the batteries at full charge.

For the best battery life, charge the cart after each use or at the end of the work day. It's preferable to let the batteries charge overnight by plugging the cart into a 110V outlet.

**Note:** If the charger indicator light goes directly to green, your batteries or charger may have gone bad, or you may have a loose connection.

### CAUTIONS AND WARNINGS

1. Before using the battery charger, read all instructions and cautionary markings on the battery charger, batteries and the product using the batteries.
2. To reduce risk of injury, charge only lead-acid type of rechargeable batteries. Other types of batteries may burst, causing personal injury or damage.
3. Do not expose charger to rain or snow.
4. To prevent the risk of fire, use the charger only in dry and ventilated rooms without flammable fluids and explosive gases.
5. Do not cover the charger with clothing, fabric or similar items during the charging process. Ventilation is important to prevent overheating.
6. To reduce the risk of damage to the electric plugs and cords, pull by the plug rather than the cord when disconnecting the charger.
7. Make sure extension cord is not used unless absolutely necessary. Use of improper extension cord could result in risk of fire and electric shock. If extension cord must be used, make sure:
  - The pins on the plug of the extension cord are the same number, size and shape as those on the charger. (3 prong with ground)
  - The extension cord is properly wired and in good electrical condition. A 16 ga cord or heavier duty extension cord is recommended.
8. Make sure charging cord is located so that it will not be stepped on, tripped over or otherwise subject to damage or stress.
9. Do not operate charger with damaged cord or plug - replace immediately if there are signs of damage!
10. Do not operate charger if it has received a sharp blow, has been dropped or otherwise damaged in any way.
11. Do not disassemble the charger.
12. Never charge a battery in an airtight enclosure.

# OPERATING INSTRUCTIONS

## SAFETY INFORMATION

- Check tire pressure and wheel condition before operating. 31 psi for pneumatic ag tires, 30 psi for 15" pneumatic turf tires, 32 psi for 13" pneumatic turf tires. Flat free semi pneumatic tires are not pressurized and do not have a valve stem.
- Only use chargers and batteries issued by Overland Carts. Use of third party batteries or chargers may cause harm to the user and the cart.
- Always make sure the hopper is latched securely before operating the cart.
- Always make sure the load is distributed evenly in the hopper and the cart is stable before operating.
- Push in the red E-Stop whenever the cart is sitting still or whenever the batteries are charging.
- Do not exceed the rated capacity of 750 pounds for the cart on flat surfaces.
- Exercise caution when operating on inclines or declines.
- Do not drive the cart over sudden drops such as curbs, steps, or ledges. We recommend using ramps to navigate uneven surfaces.
- The metal battery pack can be opened to reveal the batteries; however, the physical batteries should never be opened. They are sealed lead acid batteries and cannot be resealed. Do not attempt to add more battery acid or water. If the batteries need replaced, please purchase new batteries.

## BEST PRACTICES

- Hand wash your Overland Cart with soapy water. Never use a pressure washer.
- Do not drive your cart through deep puddles of water and do not submerge the drive system or battery box.
- The drive system is lubricated for life, so no maintenance is required.
- When the battery indicator light goes to red, it is time to recharge.
- Recharge cart immediately after using.

## POWER YOUR CART ON

To power your cart on, pull the red E-stop button out. You will notice the battery indicator lights light up and your cart is now ready for operation.

If the Overland Cart sits inactive for 20 minutes while on, it will go to sleep in order to conserve power. To wake the cart up, push the E-Stop button in, and pull it back out to power your cart on again.

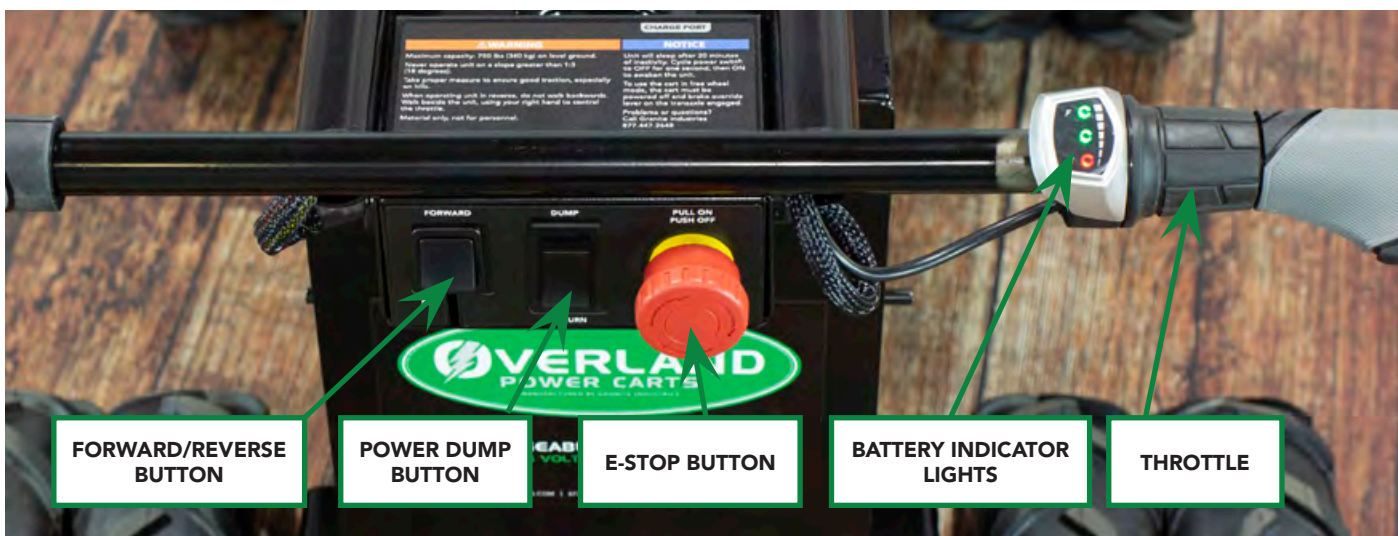

# TROUBLESHOOTING

Issue	Possible Problem	Solution
Cart will not run	Batteries are dead	Charge the Overland Cart
	E-Stop is in the OFF position	Pull e-stop out, to the ON position
	Unit is in sleep mode	Cycle the unit OFF for a couple seconds, then back ON
	Cart is in freewheel mode (brake is disengaged)	Re-engage motor brake (see free wheel mode section)
	Electrical malfunction	Disconnect and connect all electrical connections, and make sure they are all secure
	Moisture issue	Let dry, avoid getting the s-drive and battery box wet
Cart shuts off during use	Circuit breaker has tripped	Push the reset button on the battery pack (see diagram below).
	Thermal overload (weight, climb angle, or terrain may have exceeded transaxle capacity)	Release throttle, allow transaxle to cool down at least 30 seconds. Unload some weight, cycle power switch and operate machine again. Reset button will likely need to be pushed.
Cart suddenly stops	Broken or loose motor wire or connector	Check motor wires and brake wires to make sure none are broken, and also check connector to make sure wires are secure
Cart abruptly slows down while in freewheel mode	Safety feature has triggered preventing the cart from rolling away	Push the cart slower while in freewheel mode
Batteries are not lasting as long as desired	Cold batteries	Keep batteries warm
	Batteries not fully charged	Make sure your cart is fully charged before using
	Batteries are damaged or too old	Replace your batteries
	Loose wire connections	Check all connections to make sure everything is secure
Charger light goes directly to green when charging, but battery is not charged	The battery and/or charger may have gone bad	Test the charger on another battery if possible. Replace battery and/or charger
	The connections may have come loose, or disconnected	Check charger and battery connections

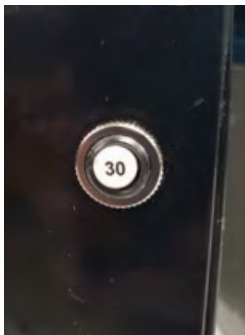

**RESET BUTTON**



The reset button is located on the top of the battery box on the 4WD Carts.



The reset button is located next to the charging port on the Ride On Carts.

# BATTERY INFORMATION

## IMPORTANT RECOMMENDATIONS

- It is recommended to wear insulated gloves when handling batteries.
- If equipment is to be stored for a long period of time, the batteries should be disconnected to avoid undue drain.
- When replacing your batteries, fasten them tightly, but do not apply undue force to the terminals or bend them.
- Do not place batteries in close proximity to objects which can produce sparks or flames.
- Avoid exposing batteries to heat.
- Do not mix batteries with different capacities, different ages or different makes.
- For best results and generally acceptable performance and longevity, keep operating temperature range between 5° F (-15° C) and 122° F (50° C)
- It is good practice to ensure that the connections are re-torqued and the batteries are cleaned periodically.
- Do not attempt to disassemble batteries. Contact with sulfuric acid may cause harm. If it should occur, wash skin and clothing with liberal amounts of water.
- Batteries should not be stored in a discharged state or at elevated temperatures.
- Please recycle old batteries. Do not throw them away, or attempt to burn them. Attempting to burn batteries (new or old) may cause them to rupture or explode.

## BATTERY FEATURES

- Absorbent Glass Mat (AGM) technology for superior performance.
  - AGM design ensures the acid inside the battery is spill-proof
  - Vibration resistant
  - Better performance in cold temperatures
  - Faster charging
  - Longer expected life
- Valve regulated, spill proof construction allows safe operation in any position. However upside down is not recommended.
- Maintenance free design. There is no need to add electrolyte as gases generated during the charge phase are recombined in a unique oxygen cycle.
- Power/volume ratio yielding unrivaled energy density.
- Special separators, advanced plate composition and a carefully balanced electrolyte system ensure the battery has the ability to recover from an excessively deep discharge.
- All batteries feature a series of low pressure, one-way relief valves. These valves safely release any excessive accumulation of gas inside the battery and then reseal themselves.
- Batteries may be discharged over a temperature range of -4° F (-20° C) and 140° F (60° C), and charged at temperatures ranging from -5° F (-15° C) and 122° F (50° C). For best results we recommend charging the batteries at room temperature.
- The case is made of ABS UL94:HB plastic. This material has great resistance to shock, vibration, chemicals and heat.
- ISO 9001:2015 Compliant
- Approved for transport by air DOT, IATA, FAA, & CAB Certified



## 4WD CARTS

The following pages contain information that relates to the below carts. Although the hopper styles may be different, the parts, chassis and wiring is similar. 34 Series carts feature an articulated chassis that is hinged at the rear axle, as well as 2 drive transaxles. Some of these carts also come with a power dump option.



**C34-8FP (70174)**

8 Cu. Ft. Hopper, 13" Flat Free Dual Ag front and rear tires, 4WD & Power Dump

**C34-8F (70236)**

8 Cu. Ft. Hopper, 13" Flat Free Dual Ag front and rear tires & 4WD

**C34-10FP (70173)**

10 Cu. Ft. Hopper, 13" Flat Free Dual Ag front and rear tires, 4WD & Power Dump

**C34-10F (70255)**

10 Cu. Ft. Hopper, 13" Flat Free Dual Ag front and rear tires & 4WD

# OPERATING INSTRUCTIONS - 4WD CARTS

## DRIVING YOUR CART

Once your cart is on, make sure your forward/reverse button is toggled upwards for forward. Twist the throttle towards you and the cart will begin moving forward. While driving your Overland Cart forward, stay directly behind the cart with both hands on the handles. When operating the cart in reverse, do NOT stand in the path of the cart and walk backwards. Instead, turn around and stand beside the unit to prevent accidental injury.

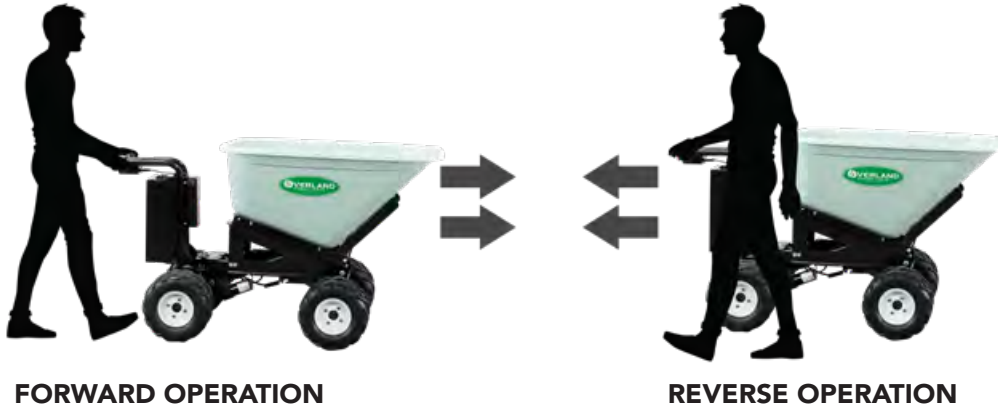

## SLOPES AND INCLINES

When going downhill, operate your cart in reverse, leading the cart downhill with the handles first. This will prevent your cart from tipping over, especially if it is carrying a full load. Do not drive your cart or ride on cart across an incline, this may cause the cart to roll over on its side. Always travel parallel with the slope or incline.

## FREE WHEEL MODE

The drive system is equipped with a lever that overrides the electromechanical brake for manually operating your Overland Cart. The brake lever allows you to override the electric brake when you need to push the cart manually, when loss of power had occurred. With the brake in the disengaged position, the E-Stop button must be pushed in, and the power turned off or the drive system will not move freely. The controller will NOT operate the motor when the brake is disengaged.

When the lever is in the up position the brake is engaged. When the lever is in the down position, the brake is disengaged. When you reset the brake system the unit will not operate until you toggle the power button off and back on. This process will need to be repeated every time the brake is manually disengaged.

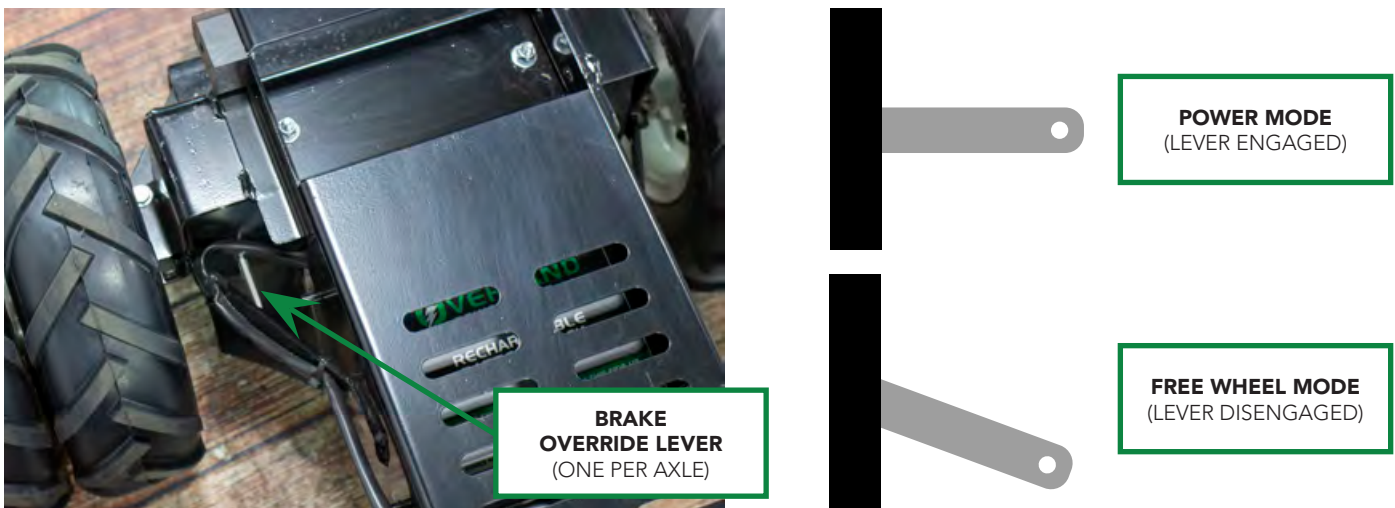

## USING THE HOPPER - 4WD CARTS

Before loading the hopper, make sure the g-pin is latched in place, locking the hopper to the cart.

There are multiple ways to dump the hoppers:

### DUMPING THE HOPPER ONLY

Disengage the g-pin, located on the right side of the cart. This unlocks the hopper from the cart frame. Lift the hopper up and forward to dump the contents. Lock back in place when finished.

### POWERED DUMP

(NOT AVAILABLE ON ALL MODELS)

Some models are equipped with a power dump feature. This option allows you to dump the cart with the push of a button. The Power Dump button is located in the



center of the control panel, between the forward/reverse button and the E-Stop.

For a controlled dump, make sure the hopper is locked to the cart frame with the g-pin located at the back of the hopper.

Push and hold the rocker button in the up position. To return the hopper, push and hold the rocker button in the down position.

For a quick release dump, unlock the g-pin and follow the previous steps. When the load reaches a tipping point, the hopper will quickly fall forward, emptying its contents.



Power dump feature



Quick release feature on the power dump cart



# BATTERY REPLACEMENT - 4WD CARTS

## TOOLS

10 mm wrench & socket

#1 or #2 Phillips screwdriver



**1** Disconnect the wires going to the battery box. Remove the battery from the cart by taking out the hair pin and removing the rod. Slide the battery box out from its housing.

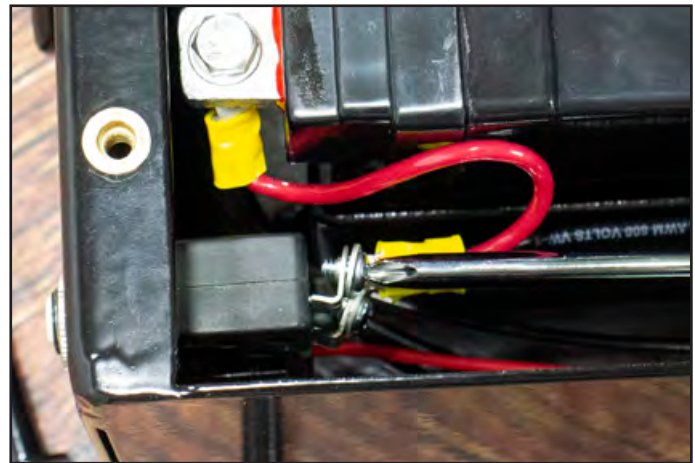

**2** Remove the four (4) #10 screws from the lid. Open the lid to expose the batteries. Then, remove the screw connecting the short red wire to the reset button.



**3** Carefully remove the battery, and disconnect the nut & bolt connectors.



**4** Repeat step 3 for the second battery. PLEASE RECYCLE YOUR OLD BATTERIES



## BATTERY REPLACEMENT - 4WD CARTS

# 5

Reconnect the batteries to the power connector, circuit breaker and charging port as shown below. Do not actually remove the power connector, charging port and breaker from the battery box. They are shown this way below for a better visual.

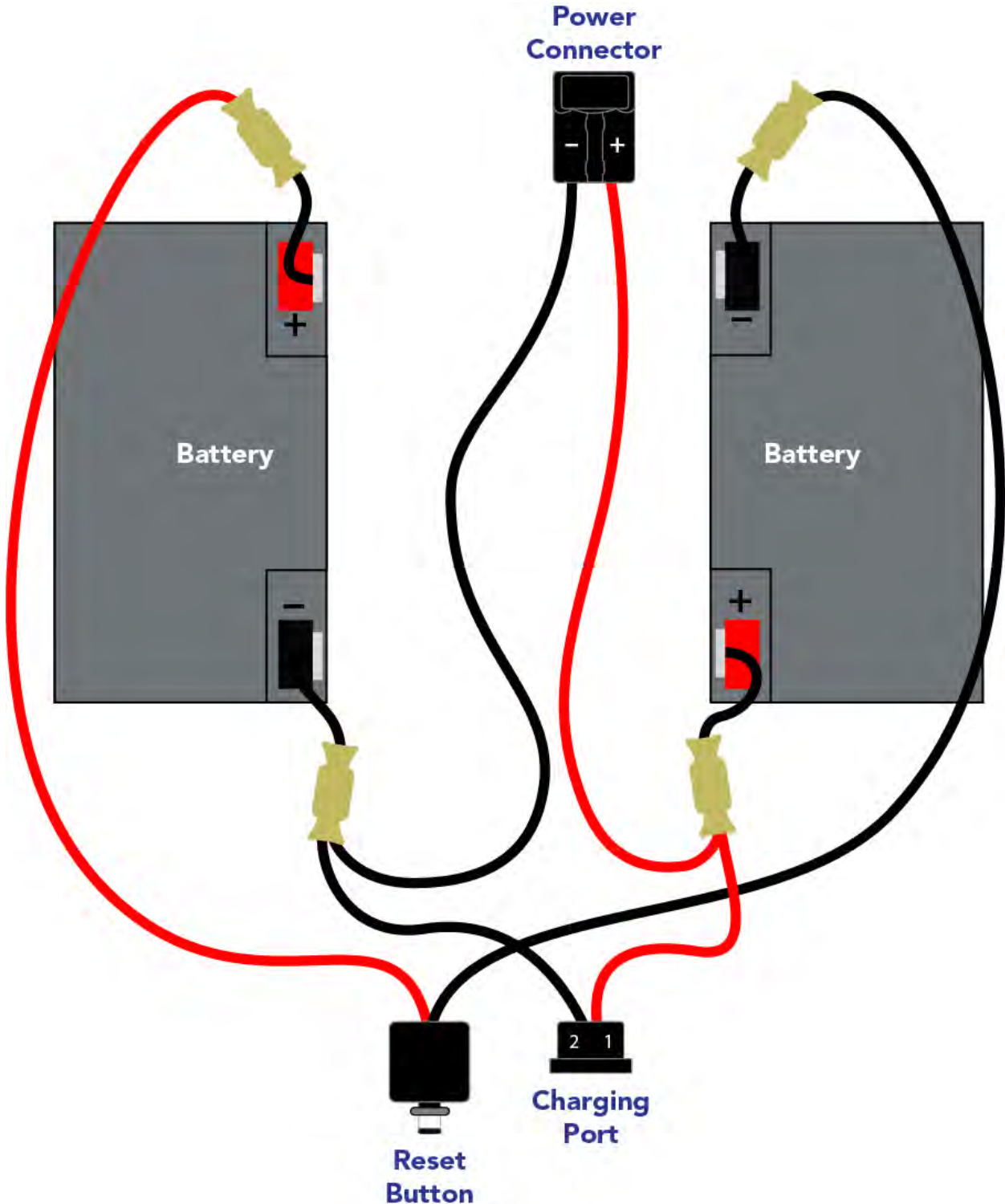

## BATTERY REPLACEMENT - 4WD CARTS

6

Place the batteries back into the box one at a time. Make sure the **terminals are upright**. Tuck the wires into the box and out of the way.

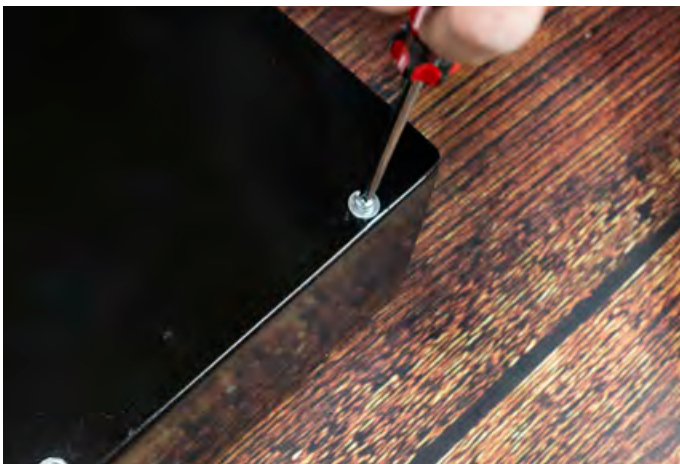
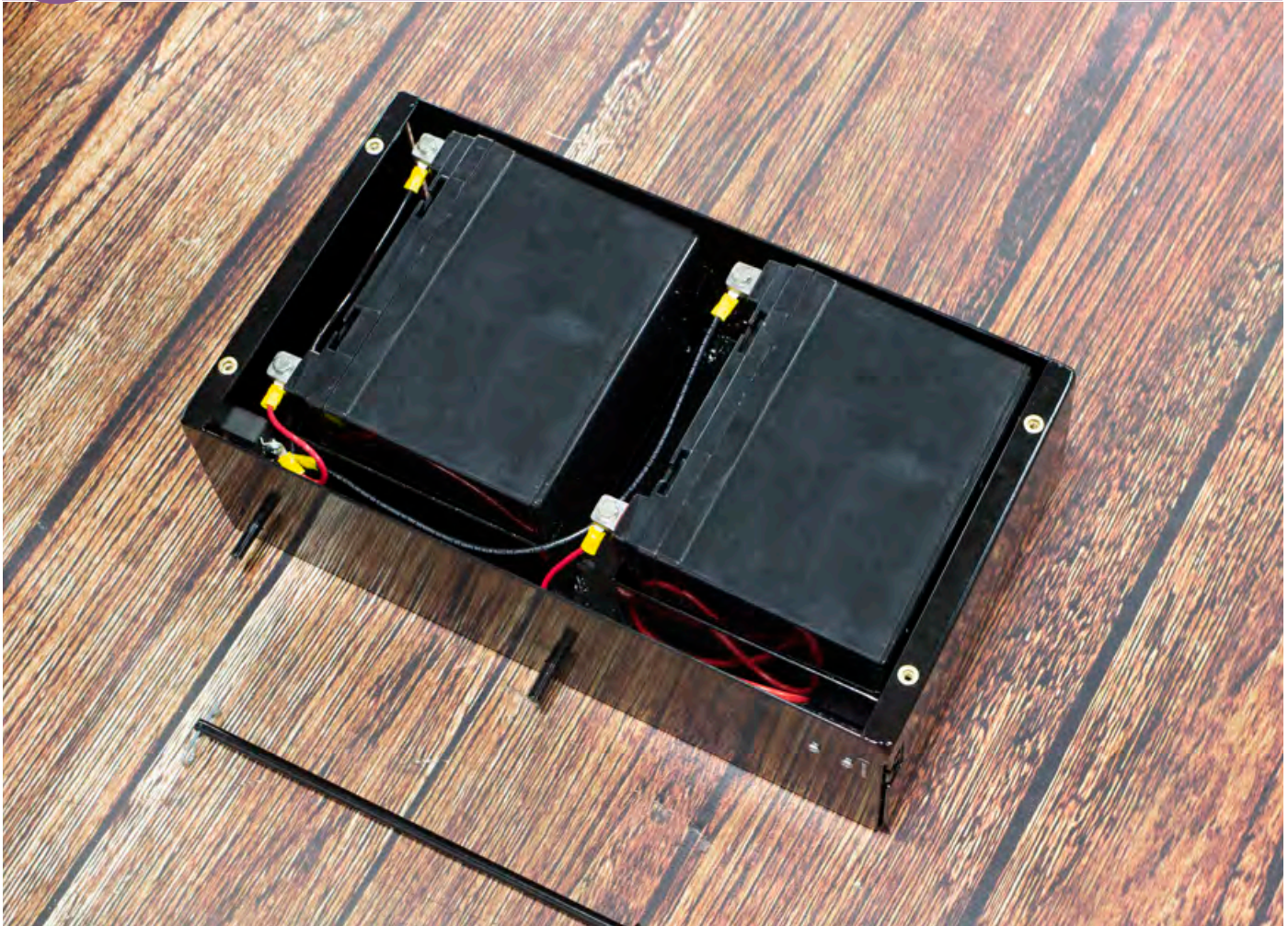

7

Replace the box lid and secure with four (4) #10 screws.



8

Place the battery box back onto the cart, insert the rod and secure with the hair pin. Reconnect the wires to the power terminal. Charge overnight before use.



# PARTS DIAGRAM - 4WD CARTS

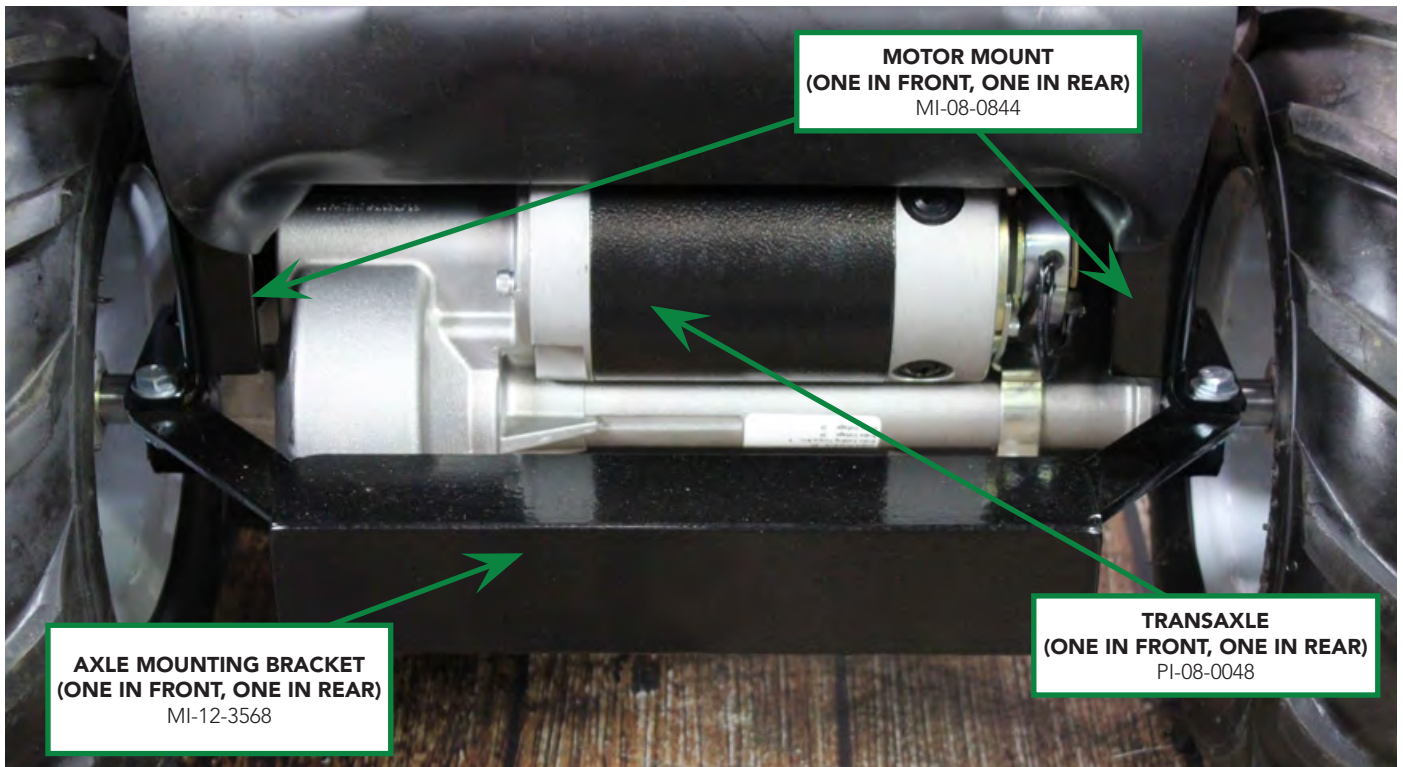



# PARTS DIAGRAM - 4WD CARTS

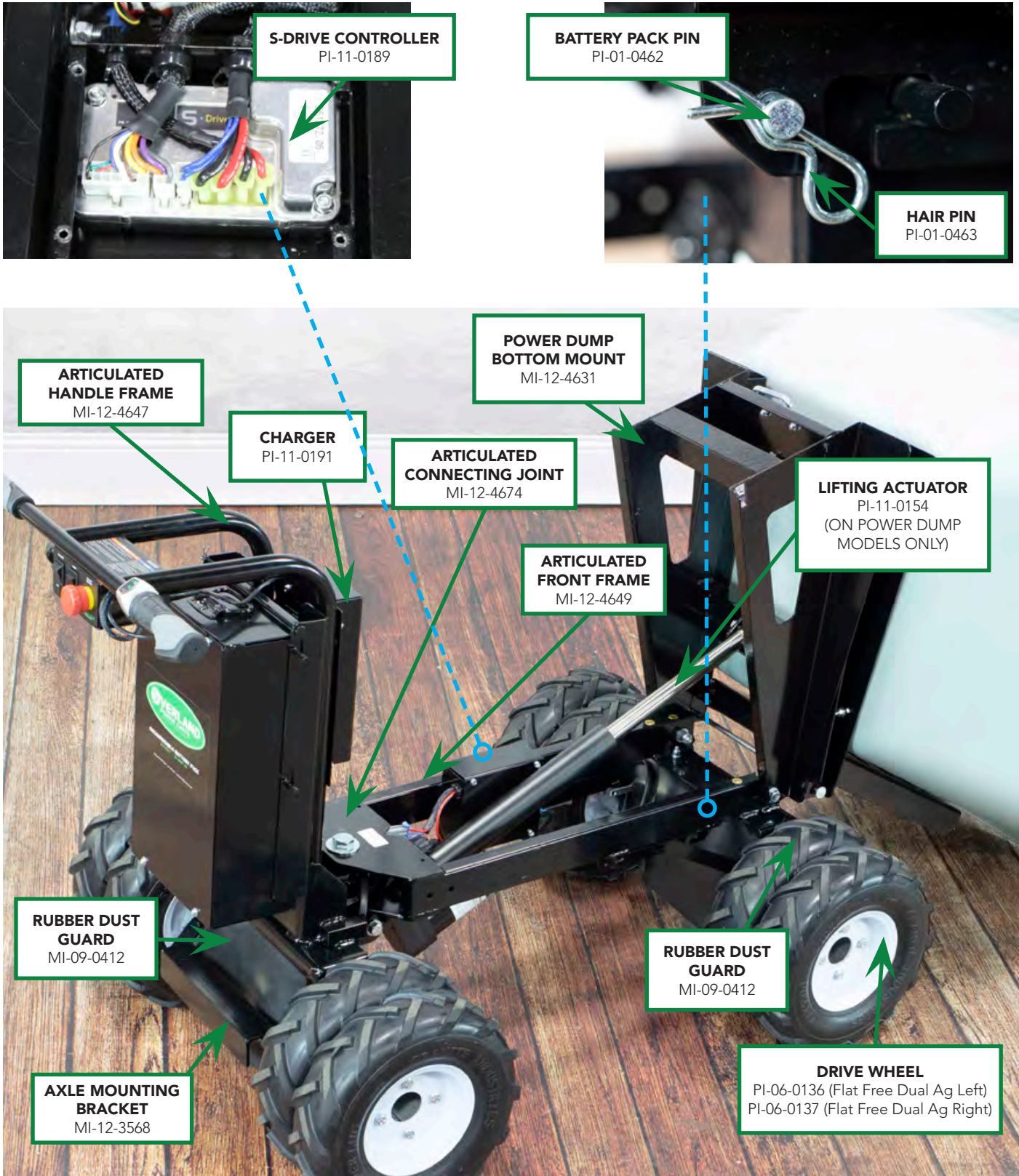



# WIRING DIAGRAM - 4WD CARTS WITH POWER DUMP

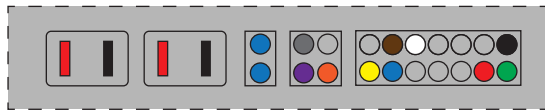

CLOSE UP OF S DRIVE CONNECTIONS

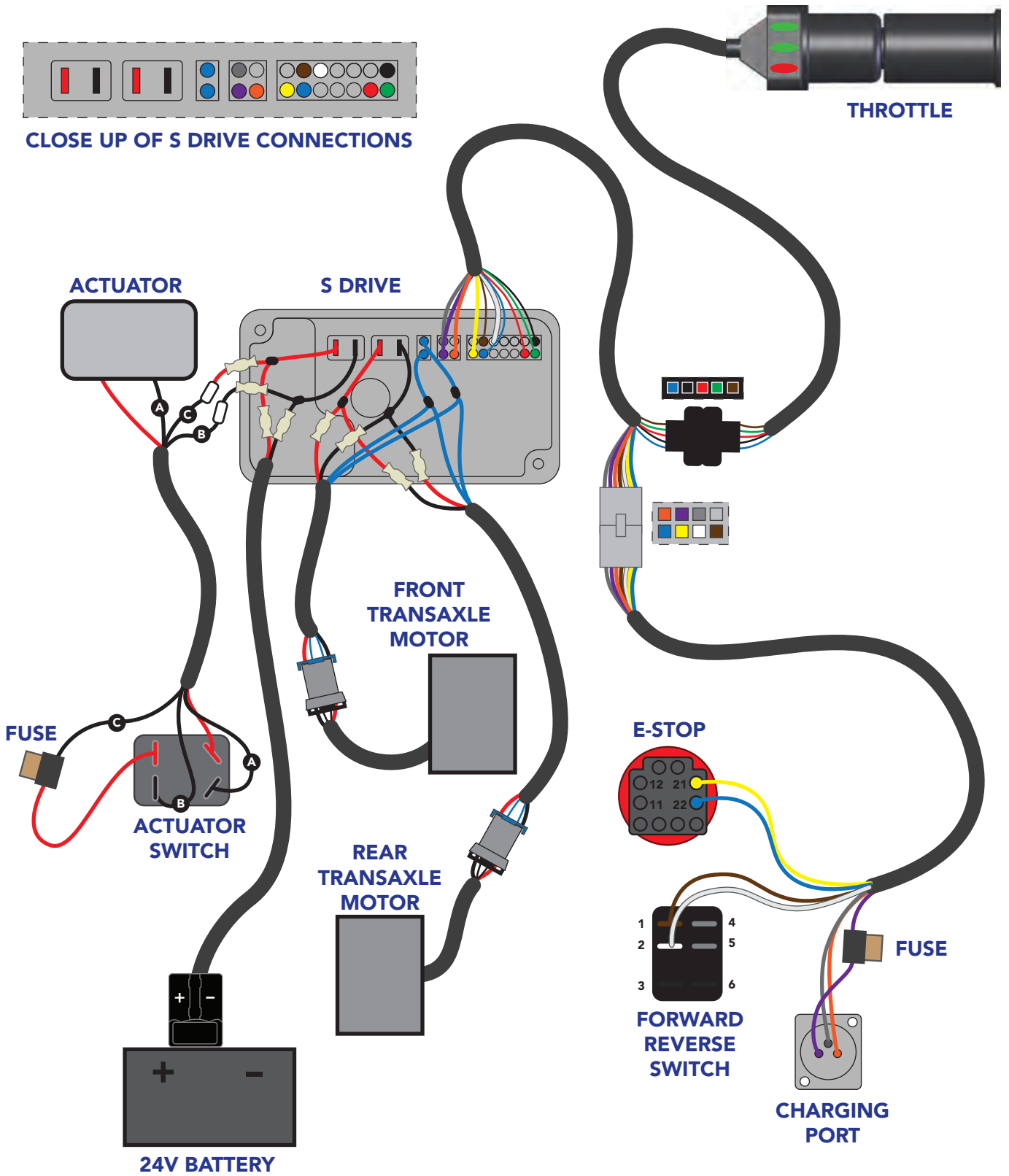

# WIRING DIAGRAM - 4WD CARTS WITHOUT POWER DUMP

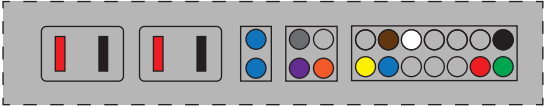

CLOSE UP OF S DRIVE CONNECTIONS

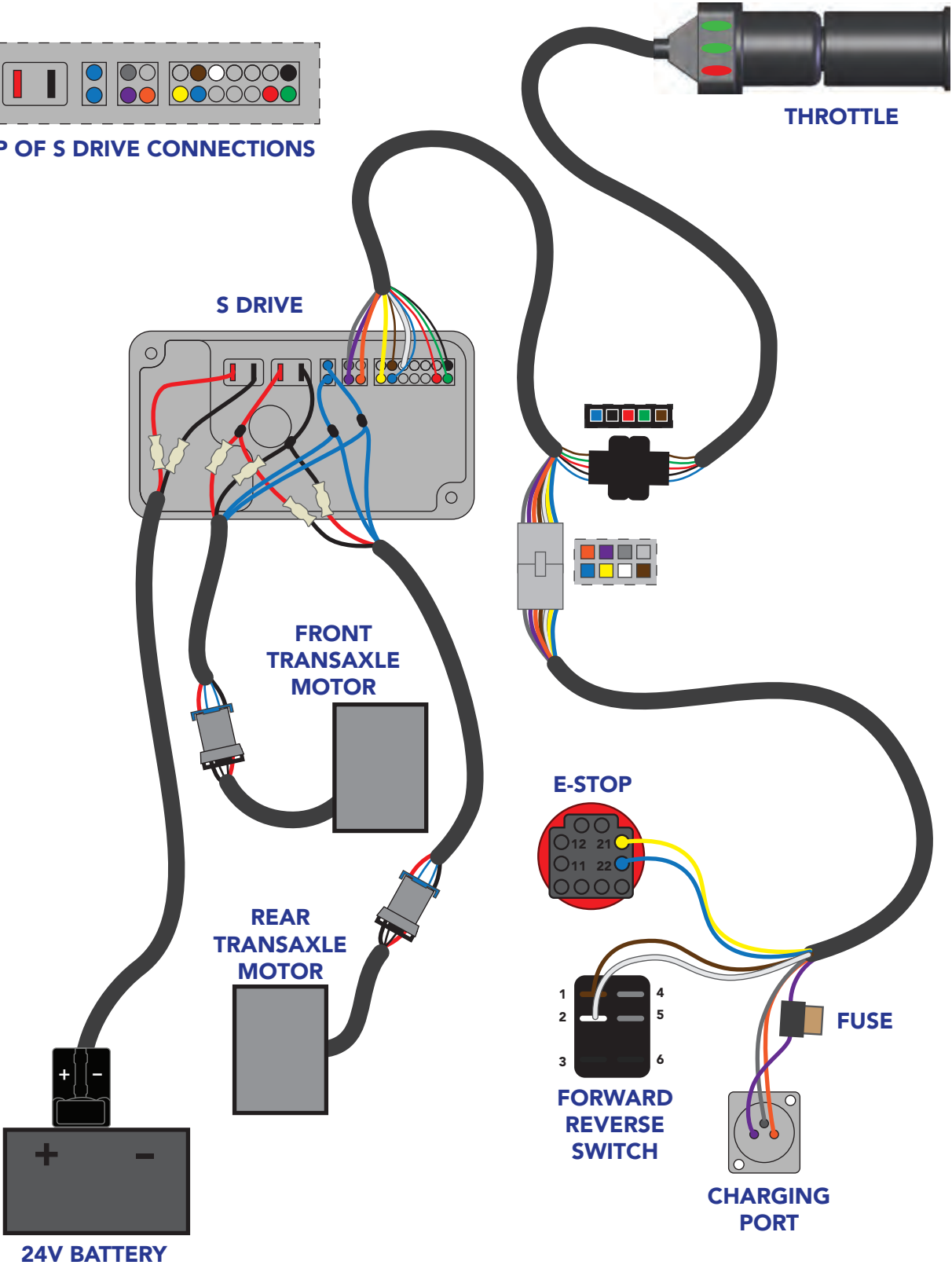

## RIDE ON CARTS

The following pages contain information that relates to the below carts. Although the hopper styles may be different, the parts, chassis and wiring is similar.



**C54-R10T (70184)**

Ride on cart with 10 cu ft hopper and 15" turf tires

**C54-R10F (70174)**

Ride on cart with 10 cu ft hopper and 15" turf tires on front and flat free dual ag tires on rear

**C54-R8T (70201)**

Ride on cart with utility box and 15" turf tires

**C54-R8T (70218)**

Ride on cart with 10 cu ft hopper and 15" turf tires & single ag tires on rear

## DRIVING YOUR CART - RIDE ON CARTS

Stand on your cart with one foot on each foot rest. Pull the red E-stop button towards you to power the cart on and make sure your forward/reverse button is toggled upwards for forward. Twist the throttle towards you and the cart will begin moving forward. While driving your Overland cart, keep your hands and feet in position while the cart is in motion. Do not attempt to jump on or off the cart while it is moving. Be aware of your surroundings at all times to prevent injury to yourself or others.

Do not drive your cart across an incline, this may cause the cart to roll over on it's side. Always travel parallel with the slope or incline.



## USING THE HOPPER - RIDE ON CARTS



Before loading the hopper, make sure the g-pin is latched in place, locking the hopper to the cart.

Disengage the g-pin, located on the right side of the cart. This unlocks the hopper from the cart frame. Lift the hopper up and forward to dump the contents. Lock back in place when finished.



The wagon style hopper can also be dumped in the same manner as the wheelbarrow style hopper. For large items that you don't wish to dump, the sides of the wagon can easily be lifted off to access the load.



# BATTERY REPLACEMENT - RIDE ON CARTS

## TOOLS

10mm wrench and socket

#1 or #2 Phillips screwdriver

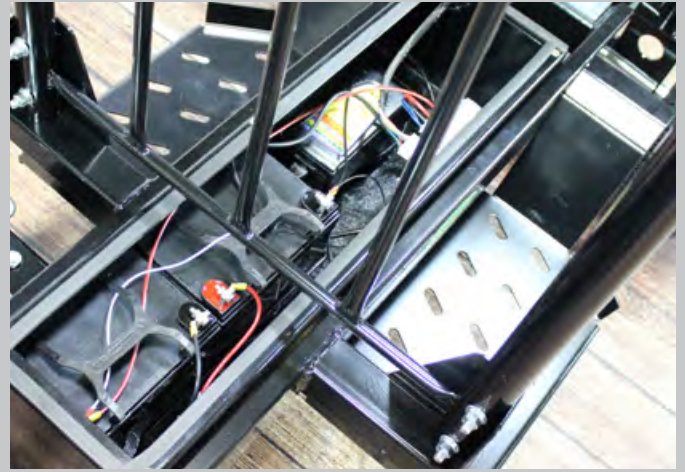

# 1

Pull the G-pin and put the hopper in the dump position to view the access panel.



# 2

Remove the six (6) #10 screws holding the lid in place. Remove the lid and set aside.

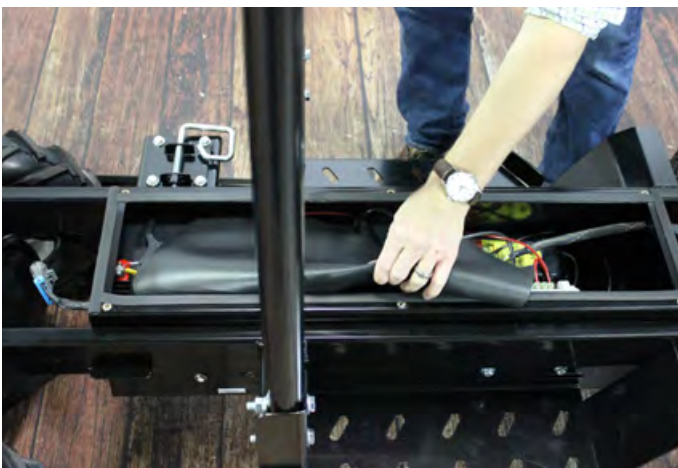

# 3

Remove the rubber sheet on top of the batteries and wiring and set aside.



# 4

Using a 10mm socket & wrench, disconnect the wires from the terminals. Set the washers, nuts and bolts aside.

## BATTERY REPLACEMENT - RIDE ON CARTS

# 5

Remove and recycle the old batteries. Place new batteries into the unit.



**35/39 AMP-HR  
BATTERY**  
PI-11-0025

# BATTERY REPLACEMENT - RIDE ON CARTS

# 6

Connect the terminals using the diagram below to assist you. Replace the rubber membrane, and lid. Secure the lid with the six (6) screws, and lower the hopper into place. Charge your unit overnight before using.

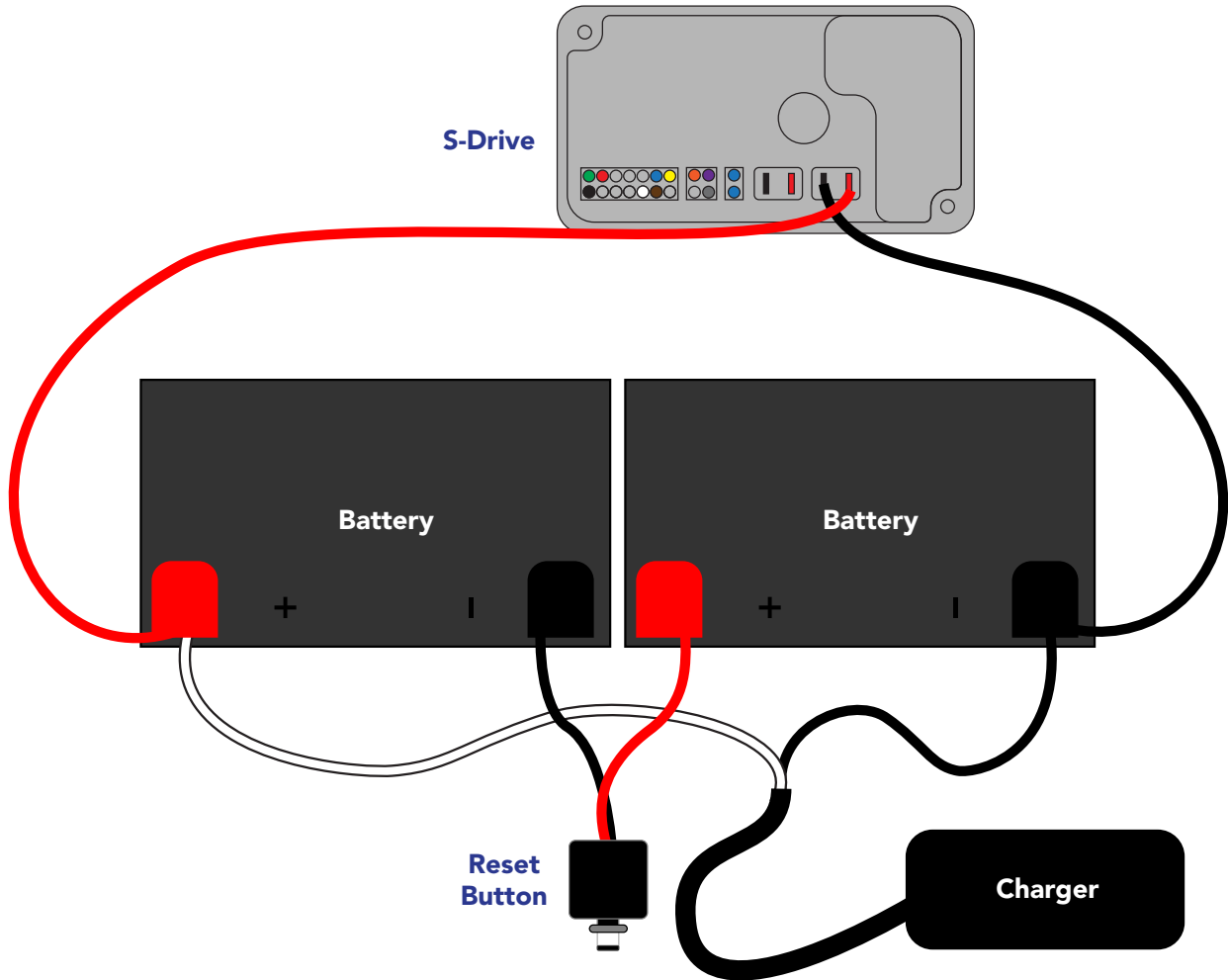

## ORDER FOR ASSEMBLY

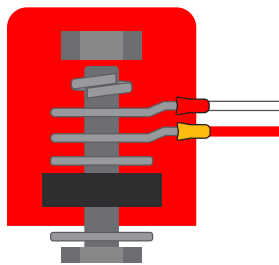

Nut  
Lock Washer  
White Wire (Charger)  
Red Wire (S-Drive)  
Washer  
-Terminal-  
Washer  
Bolt

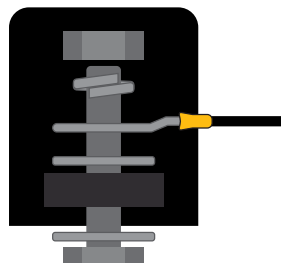

Nut  
Lock Washer  
Black Wire (Reset)  
Washer  
-Terminal-  
Washer  
Bolt

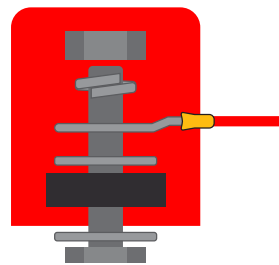

Nut  
Lock Washer  
Red Wire (Reset)  
Washer  
-Terminal-  
Washer  
Bolt

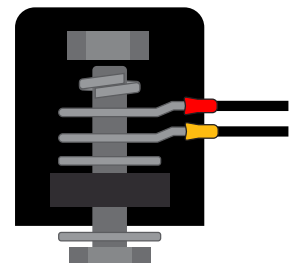

Nut  
Lock Washer  
Black Wire (Charger)  
Black Wire (S-Drive)  
Washer  
-Terminal-  
Washer  
Bolt



# PARTS DIAGRAM - RIDE ON CARTS

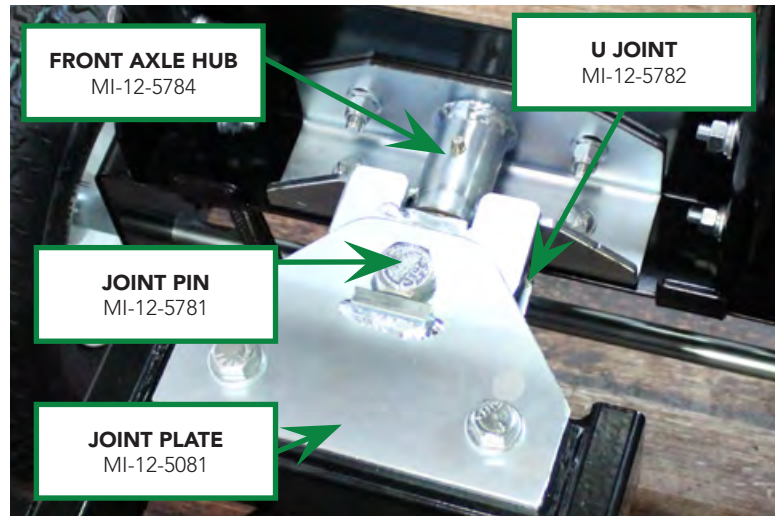
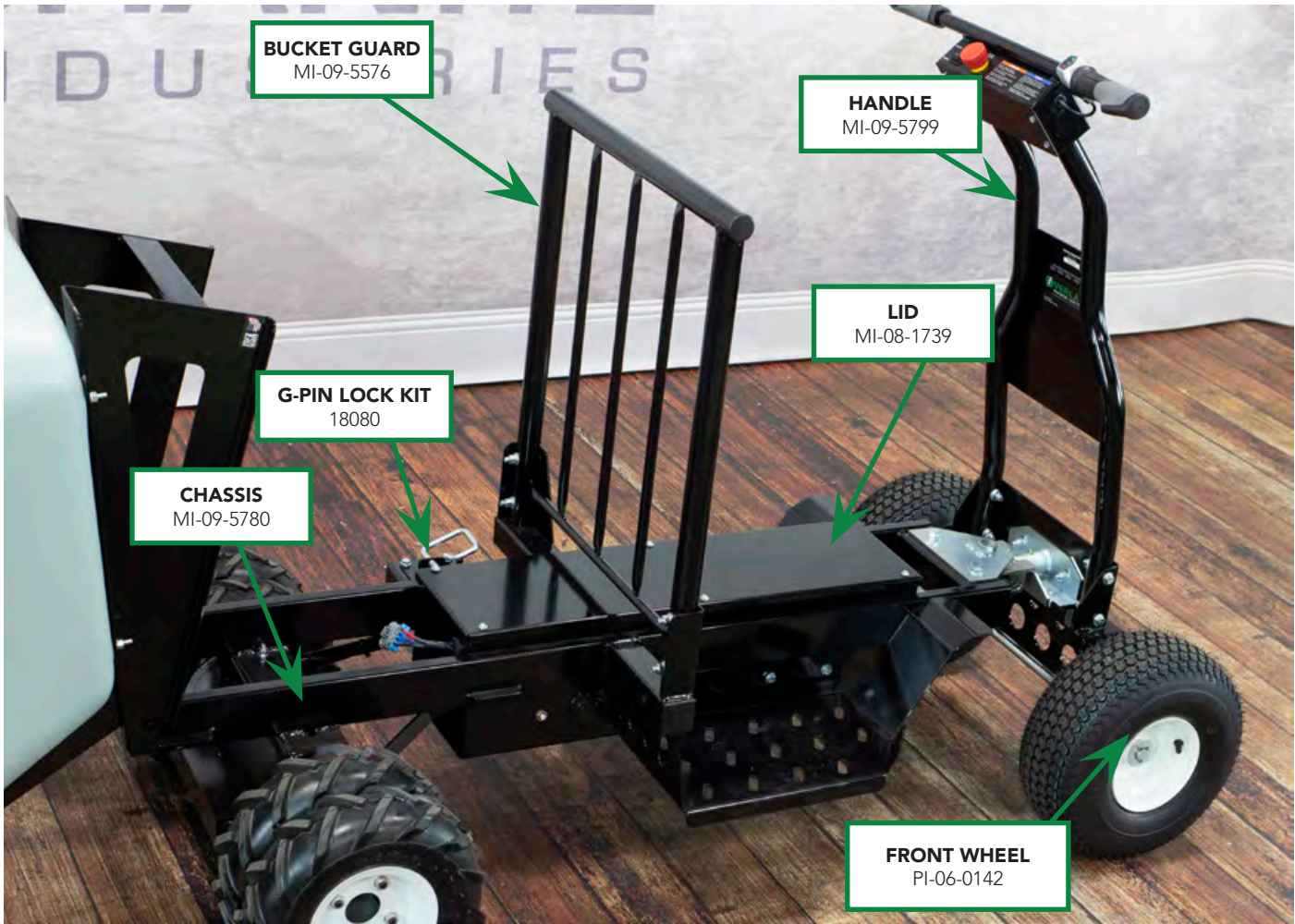

# WIRING DIAGRAM - RIDE ON CARTS

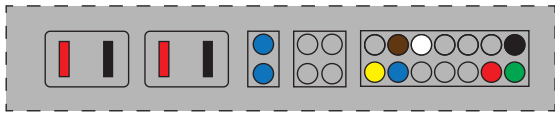

CLOSE UP OF S DRIVE CONNECTIONS

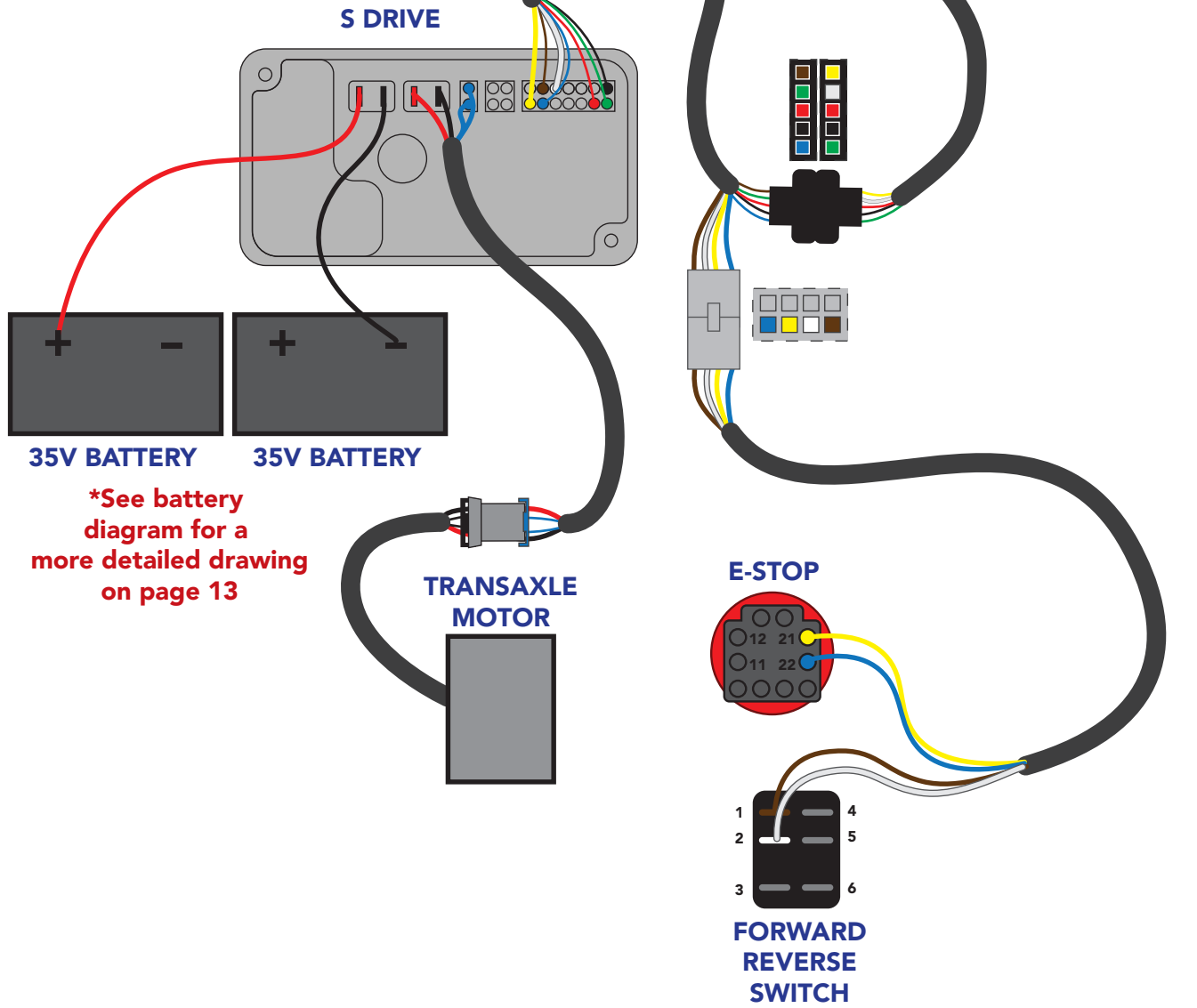

## ADDITIONAL REPLACEMENT PARTS



13" Flat Free Dual Ag  
PI-06-0136 (Left)  
PI-06-0137 (Right)



13" Flat Free Single Ag  
PI-06-0147 (Left)  
PI-06-0148 (Right)



15" Turf Tire  
Drive Wheel  
PI-06-0131



15" Turf Tire  
Non-Drive Wheel  
PI-06-0142

Part No	Description	Weight	Dimensions
PI-06-0137	13" Right Flat Free Dual Ag Tire	30 lb	13" Diameter - 8"W
PI-06-0147	13" Left Flat Free Single Ag Tire	16 lb	13" Diameter - 4"W
PI-06-0148	13" Right Flat Free Single Ag Tire	16 lb	13" Diameter - 4"W
PI-06-0120	13" Left Single Ag Tire	8 lb	13" Diameter - 4"W
PI-06-0121	13" Right Single Ag Tire	8 lb	13" Diameter - 4"W
PI-06-0131	15" Turf Tire Drive Wheel	12 lb	15" Diameter - 6"W
PI-06-0142	15" Turf Tire - Non-Drive Wheel	9 lb	15" Diameter - 6"W
PI-11-0212	12 ft E-Strap	2 lb	12' L



8 Cu Ft  
Brentwood Hopper  
PI-11-0181 (Hopper Only)  
70130 (Hopper & Frame)



10 Cu Ft  
Brentwood Hopper  
PI-11-0152 (Hopper Only)  
70107 (Hopper & Frame)



Battery Pack - 21A  
70124



Charger for 70124  
PI-11-0191



Battery Pack - 35/39A  
70171



Charger for 70113  
PI-11-0027

Part No	Description	Weight	Dimensions
PI-11-0181	8 cu ft Commercial Wheelbarrow Hopper*		
70130	8 cu ft Commercial Wheelbarrow Hopper w/ steel base	39 lb	18"H x 33.5"W x 44"D
PI-11-0152	10 cu ft Commercial Wheelbarrow Hopper*		
70107	10 cu ft Commercial Wheelbarrow Hopper w/ steel base	46 lb	14"H x 35.5"W x 62"D
70162	Ball Hitch for C34 series chassis	10 lb	8"H x 4"W x 10"D
70124	Rechargeable Battery Pack - 24v, 24 amp	38 lb	8"H x 8"W x 8"D
70171	Rechargeable Battery pack - 24v, 35/39 amp	68 lb	17"H x 9.5"W x 5.5"D
PI-11-0191	Charger for 21A, 24A & 35/39A Battery Packs ONLY - 24v 5 amp	2 lb	10' cord
PI-11-0215	24A Sealed Lead Acid Battery - 12v (2 needed per cart)	13 lb	6.5"H x 7"W x 3"D
PI-11-0025	35/39A Sealed Lead Acid Battery - 12v (2 needed per cart)	25 lb	7"H x 8"W x 5"D



# ADDITIONAL REPLACEMENT PARTS



**Transaxle**  
PI-08-0048



**S Drive**  
PI-11-0149 (70)  
PI-11-0189 (90)



**Throttle Kit**  
PI-08-0053



**Fwd / Rev Switch**  
PI-08-0061



**E-Stop Switch**  
PI-08-0075



**Power Dump Switch**  
PI-08-0067

Part No	Description	Weight	Dimensions
PI-08-0048	Transaxle	20 lb	6" H x 6" W x 24" D
PI-11-0149	S Drive 70		
PI-11-0189	S Drive 90		
PI-08-0053	Throttle Kit		
PI-08-0061	Forward/Reverse Switch		
PI-08-0075	E-Stop Switch		
PI-08-0067	Power Dump Switch		
PI-11-0154	Actuator for Power Dump		
PI-08-0045	30 Amp Circuit Breaker		
PI-08-0086	15 Amp Circuit Breaker for Power Dump		



**Actuator for Power Dump**  
PI-11-0154



**Circuit Breaker**  
PI-08-0045 (30 Amp)  
PI-08-0086 (15 Amp)

All Overland Carts are manufactured by:



**GRANITE**  
INDUSTRIES

**Granite Industries**  
595 East Lugbill Rd.  
Archbold, Ohio 43502

877-447-2648  
OverlandCarts.com | GraniteInd.com