



Click Here To View
Item at

www.GapPower.com

*Sales • Rentals
Parts & Service*



MODEL 3150/38 N18
STAPLER

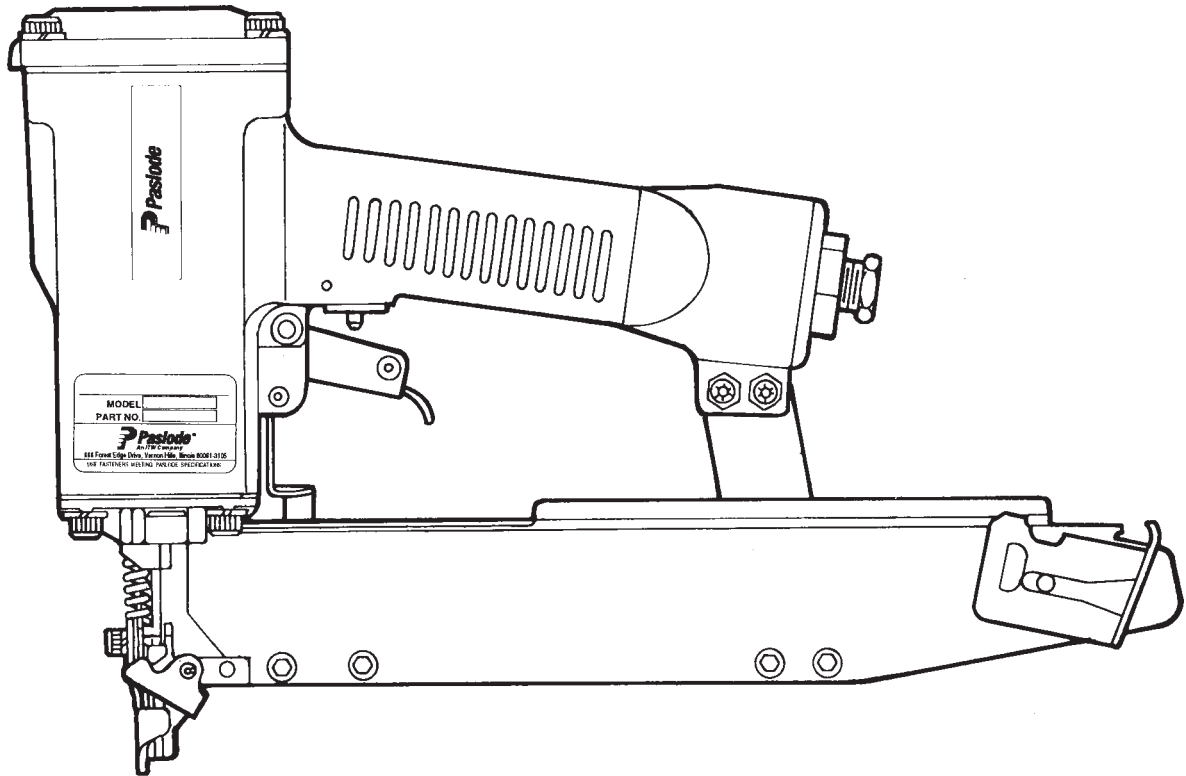

TOOL SCHEMATIC AND PARTS

IMPORTANT!
DO NOT DESTROY

Always refer to safety and operating manuals, #403606, #405218 and #405222 for detailed information on this tool. It is the customer's responsibility to have all operators and service personnel read and understand this information.

PARTS LEGEND 3150/38 N18, 403220

1	091362	4	Socket Head Capscrew, 1/4 - 20 x 1-1/2"
2	002187	4	Lock Washer, 1/4"
3	404242	1	Air Diffuser
4	006310	1	Socket Head Capscrew, #6 - 32 x 1/2"
6	402704	1	Cap
7	402717	1	Conical Spring
8	404230	1	Retaining Ring
*9	091537	1	"O" Ring, Main Valve Assembly
10	404122	1	Upper Valve Piston
11	404055	1	Post, Main Valve
*12	404256	1	"O" Ring, Main Valve Post
*13	402723	1	"O" Ring, Piston
14	403563	1	Piston
15	403582	1	Jam Nut
*16	403727	1	Driver Blade
17	402725	1	Seal, Sleeve
18	405245	1	Sleeve
*19	402728	1	"O" Ring, Sleeve
*20	402729	1	"O" Ring, Sleeve
21	403854	1	Retainer, Bumper
*22	403853	1	Bumper
23	403222	1	Seal, Driver Blade
*24	402707	1	Gasket, Cap
25	402701	1	Housing
26	404939	2	Logo, Housing
27	500692	1	Nameplate
28	402708	1	Gasket, Flange
29	402706	1	Flange
▲30	091545	4	Socket Head Capscrew, 1/4 - 20 x 7/8"
31	405144	1	Trigger
32	402079	1	Pin, Trigger
33	404325	1	Stop Nut #8 - 32
34	404054	1	Seal, Main Valve
*35	090927	1	"O" Ring
*36	092775	1	"O" Ring
37	026133	2	Roll Pin, 1/8" Dia. x 1" Lg.
38	401958	1	Valve Body
39	092174	1	"O" Ring, Valve Body
40	097746	1	Valve Pin
41	097748	1	Spring, Valve Pin
42	091591	1	"O" Ring, End Plug
43	401940	1	End Plug
44	091622	1	Reducing Pipe Bushing
45	004502	4	Socket Head Capscrew, #10 - 32 x 5/8"
46	092037	5	Lock Nut, #10 - 32
47	403219	1	Rail Bracket
48	403716	2	Socket Head Capscrew, #10 - 32 x 5/16"
50	402629	2	Hardened Washer
51	402794	1	Intermediate Work Contacting Element
*52	402738	1	Spring
53	403379	1	Work Contacting Element
*54	402734	1	Spring
55	403214	1	Front Guide
56	404698	2	Roll Pin Assembly
57	403213	1	Back Plate
58	402730	1	Pivot Pin, Front Guide
59	092178	1	Roll Pin, 5/32" Dia. x 1" Lg.
60	405078	1	Spring, Front Guide Latch
61	403215	1	Latch, Front Guide
**62	500459	1	Warning Sign
63	403753	1	Rail Cover Assembly
64	403218	1	Rail
65	403376	1	Spacer, Rail Cover
66	403380	2	Spacer, Rail to Bracket
67	403221	1	Follower
68	080326	2	Socket Head Capscrew, #10-32 x 1"
69	009059	3	Socket Head Capscrew, #10 - 32 x 3/4"
70	403217	1	Extension Spring, Follower
71	091447	4	Flat Washer
72	404243	4	Spacer, Diffuser
*73	092773	1	"O" Ring
74	404056	1	Lower Valve Piston
75	405147	1	Lever, Trigger
76	005849	1	Roll Pin
79	091966	1	O-Ring
80	405243	1	Flange
81	500488	1	Grip, Handle

* Denotes normal wear items.

** Make sure warning label (500457) is properly affixed. Replace if necessary. Label available at no charge through the Service Dept.

▲ Apply Loctite 242 (Blue) Part No. 093500

➔ Denotes new change.

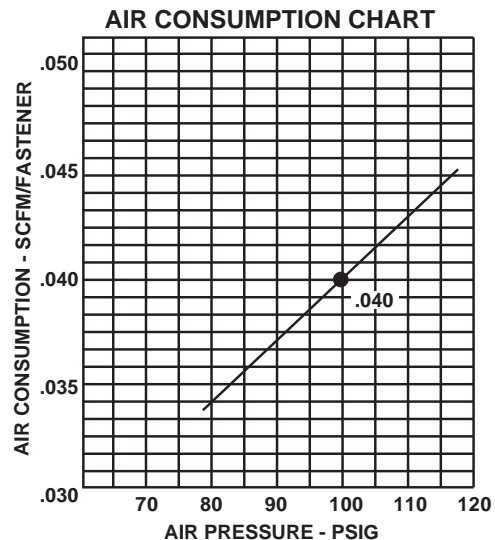

3150/38 N18

403220

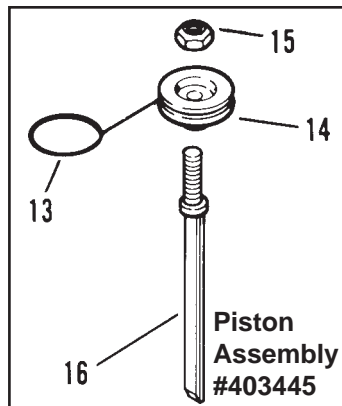
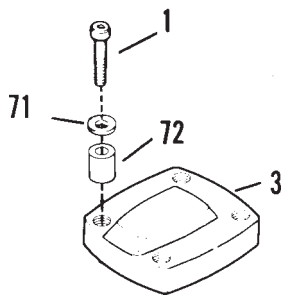

Cap Assembly #402709

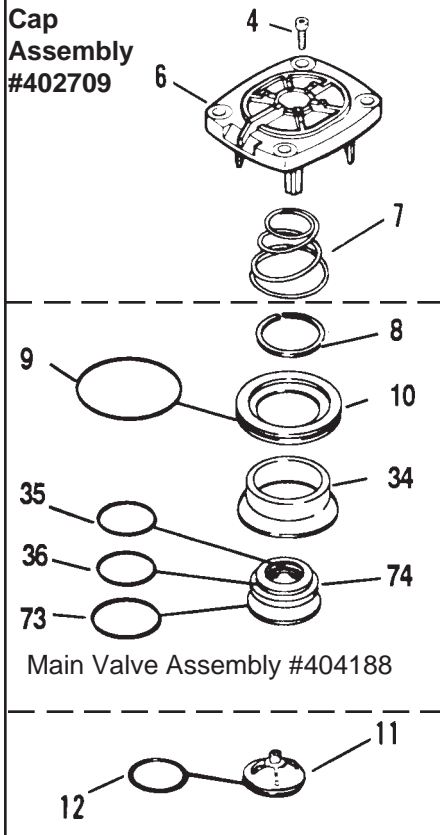

Main Valve Assembly #404188

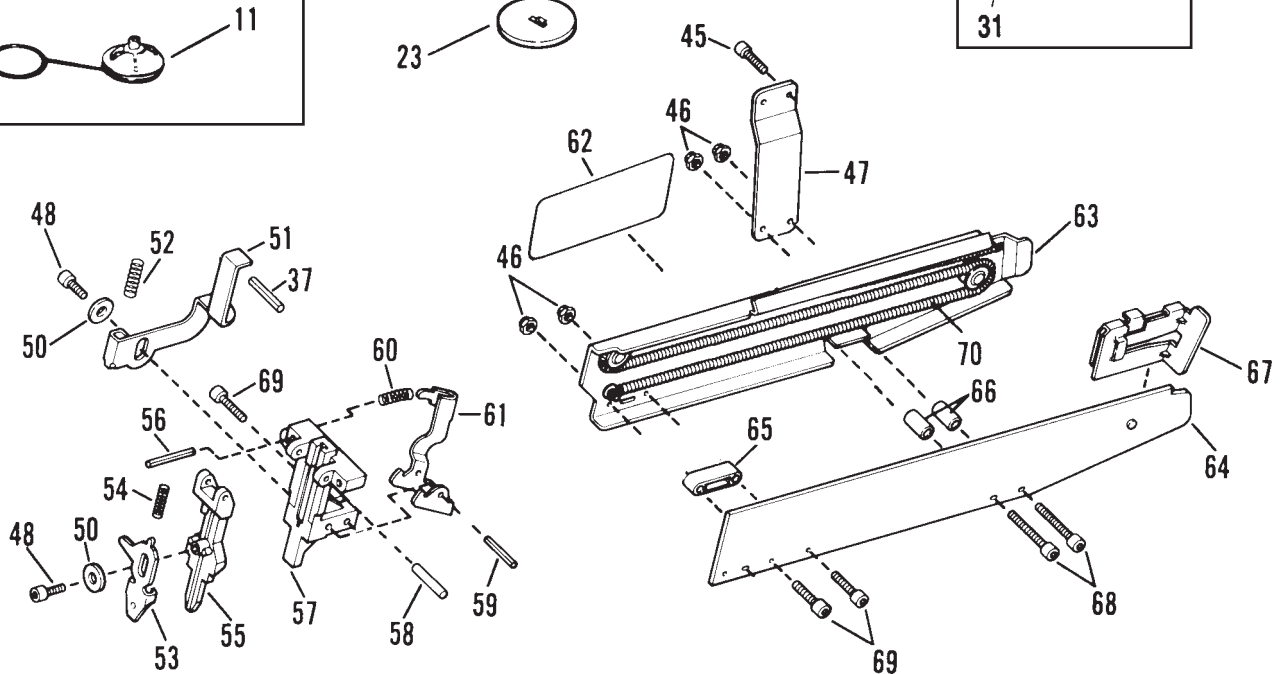
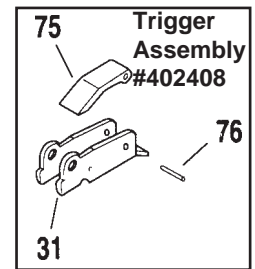

Warning

All parts must be periodically inspected and replaced if worn or broken. Failure to do this can affect the tool's operation and present a safety hazard.

ACCESSORIES

Sequential Operating Kit

This special attachment is designed for sequential operation (stops "contact firing"). The operator must depress and hold the work contacting element against the work surface before pulling the trigger. This sequence must be repeated each time the tool drives a fastener.

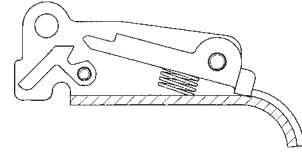

Part No. 406006

Remote Fire Valve

This valve via a positive air signal allows a machine mounted tool to be operated from an automatic air valve or foot pedal system.

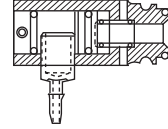

Part No. 1x0713

Tool Repair Kit

This kit repairs all air leaks except for trigger valve.

Part No. 219222

Trigger Valve Repair Kit

This kit repairs all trigger valve air leaks.

Part No. 219224

Lubricants and Loctite

- Loctite 242 (Blue) 10
- Lubricating Oil 16 oz.
- Lubricating Oil with Antifreeze
- Chemplex 710 Lubricant 1 lb.

Part No. 093500
Part No. 403720
Part No. 219090
Part No. 403734

Degreaser Cleaner

Ideal Cleaner for all Paslode Tools

Part No. 219086

Universal Belt Hook

Attaches to cap of tool enabling you to carry tool on belt holder

Part No. 219017

Belt Hook Holder

Attaches to work belt and carries tool using the above belt hook

Part No. 219028

Safety Glasses

Clear Part No. 402510
Tinted Part No. 402512

Quick Exhaust Piston

For fast cycling applications.

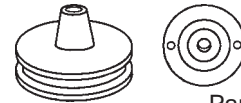

Part No. 1X363

SAFETY INSTRUCTIONS

WEAR EYE AND HEARING PROTECTION



Always wear hearing protection and eye protection devices, including side shields when operating or working in the vicinity of a tool.



Never use any bottled air or gases such as oxygen to operate the tool since they could cause the tool to explode.

DO NOT EXCEED MAXIMUM RECOMMENDED AIR PRESSURE

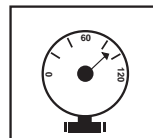
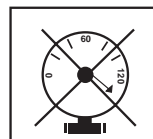

Operate the tool using only the recommended air pressure. Do not exceed the maximum air pressure marked on the tool. Be sure the air pressure gauge is operating properly and check it at least twice a day.



An Illinois Tool Works Company
888 Forest Edge Drive
Vernon Hills, Illinois 60061