

MENEGOTTI TECHNICAL MANUAL

CONCRETE MIXER

PROFESSIONAL 11 CuFt

PROFESSIONAL 7 CuFt



QR-Code:



Point your mobile phone or tablet camera to access the updated version of **Technical Manuals** and **Parts Catalogs** online, or click the link below to access the website.

www.mgtamerica.com

Attention:

Before operate **Menegotti equipment**, read this **technical manual**, itself will inform and instruct the operator about the operation. By the way, you avoid possible working accidents and early maintenance on at the equipment.

MENEGOTTI
NORTH AMERICA 

Congratulations, you have just purchased a Menegotti product!

With the highest quality, projected and built especially to serve your needs.

This manual was elaborated to provides the informations and key instructions to use and maintain our product, in addition presents their technical characteristics.

Before use the product for the first time, read and pay attention at the informations in this manual.

The product durability only depends the way you treat it in service (operation) and the satisfactory working is consequence of yours regular work carefully.

Menegotti is prepared to offer you all technical assistance, and attend all your needs about replacement parts.

Welcome, you are part of the huge Menegotti “customers family”.

After sales Department
and Technical Assistance MENEGOTTI.

Attention: For better comodity, store and keep this manual in a properly spot so it can be easily checked.

Index

Menegotti Group.....	03
The Product.....	03
Safety Informations.....	03
Technical Specifications.....	04
Main Parts.....	05
Operation Conditions.....	06
Cleaning and Conservation.....	06
Grounding the Equipment.....	06
Equipment Lubricacion.....	07
Transport, Lifting and Towing.....	07
Wiring Diagram.....	08
Equipment Operation.....	09
Equipment Maintenance.....	10
Assembly Procedures.....	10
Characteristics.....	12
Parts List.....	13
Product Warranty.....	23
Term of Warranty.....	23

Menegotti Group

Menegotti is reference in the development of solutions in machines and tools for the Construction machinery, Handling and Lawn | Garden Segments.

A Brazilian company, present in more than 40 countries, has its headquarters in Jaraguá do Sul, Santa Catarina, units in Brazil and in the United States.

With more than 80th years of history, it is in the fourth generation of consistent and successful family management.

National leader in sales of concrete and cement mixers, it stands out in the resale and rental market.

Through its Innovation Program, it fosters creativity and competitiveness, with disruptive actions and partnerships, aimed at continuous professional and business growth.

With an organizational culture that values and encourages its constant professional and personal development, Menegotti is active in sustainable projects, which make its purpose of contribute “to build a better and more sustainable world”, a reality.



The Product

The concrete mixer was designed for heavy civil construction work. It is composed of a drum that is moved by a drive (electric/diesel/Petrol), which is activated by a driven /drive system with a “V” belt . The unloading system is manual.

• **With the aim of constantly improving their equipment, Menegotti reserves the right to change the features of the product without notice.**

Safety Informations

Note: Anyone who performs any type of operation with this equipment must read this manual and the safety instructions.



- Before using this equipment, carefully read this manual and follow the Manufacturer`s instructions, such as how to reduce the risk of accidents in operation.
- It is expressly prohibited to remove or alter any safety device or characteristic, should this occur MENEGOTTI will not be held responsible.
- Use the equipment according to the instructions in this manual.
- In the case of damaged or missing pieces, contact MENEGOTTI by phone at 770 910 7450 for replacement of same.
- With the machine turned off, conduct a daily inspection of the machine parts. In the case of problems, immediately contact the MENEGOTTI authorized service.
- Maintain a limited area exclusive for working with the equipment, always keeping the place clean, without obstructions and with good lighting;
- The operator must be trained or qualified to operate this equipment;
- Do not use clothing that is too loose and which might get caught in the machine.
- Always use gloves, safety goggles and ear protection.
- The engines must be installed by qualified professionals.



- Perform the maintenance recommended in this manual with qualified people and within the stipulated periods.
- Inspect all electrical extensions, mainly for cuts, cable friction and broken connections;
- Never use extensions that are not in good condition.
- Never use wet extensions or operate in wet environments (e.g. Pools of water).
- When cleaning the equipment, never throw water on the engine.
- Whenever performing maintenance on this equipment, disconnect the power cable from the source..
- Avoid contact with hot surfaces.
- Before performing any activity or maintenance, first let the engine cool down.
- Avoid contact with rotating parts.

Technical Specifications

SPECIFICATIONS	PROFESSIONAL 11 CuFt	PROFESSIONAL 7 CuFt
Total Drum Volume	14 Cu Ft	9 Cu Ft
Output Capacity (Mixed)	11 Cu Ft	7 Cu Ft
Drum Rotation	30 Rpm	30 Rpm
Number of Cycles/Hour	15	15
Production per hour	164 Cu Ft ³	106 Cu Ft ³
Drive Capacity	Electric: 2 CV	Electric: 1 CV
	Combustion: 5 - 5.5 HP	Combustion: GX 160 5.5 HP
Power Supply	Electric*: 110/220/380 V	Electric*: 110/220/380 V
	Combustion: Gasoline/Diesel	Combustion: Gasoline/Diesel
Weight without Engine	485 Lbs	458 Lbs
Dimensions (H x L x W)	1576 x 2045 x 1145 mm	1576 x 1850 x 1350 mm

* Consult availability and instruction for changing switch selector to electrical supply.

Main Parts

POS.	DESCRIPTION
1	Drum
2	Steel Yoke
3	Motor Box
4	Chassi
5	Wheel

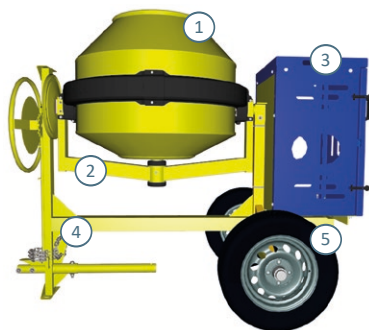

Equipment supplied with Electric Engine

- Before switchn your concret mixer, check if the supply voltage corresponds to the voltage indicated on the identity plate of the electric engine. Switching on the engine when connected to different voltage from the voltage indicated on the identity plate of the electric engine will result in damage to the engine;
- For without voltage selector equipment, contact the authorized service prior to any change.
- The engine drive in a different voltage voltage on the electric engine plate resulting in engine damage;
- Make sure circuit breakers, electric cables, sockets, grounding are compatible with the specified engine;
- Accepted voltage variation must not exceed variations above or below 10%, otherwise running failures may occur or even burning of the engine;
- For use of an extension electric, we recommend the table:

CONCRETE MIXER

Extension electric	0 a 20m	20 a 30m	above de 30m
Diameter of the electric wire	4,0 mm ²	6,0 mm ²	not recommended

Equipment supplied without Electric Engine

The engine installation, electrical appliances and their installations and grounding must be made in accordance with current standards in the region and accompanied by a responsible qualified function. In the absence of such standards, should be carried out according to international standards, doubts when installing contact the authorized service.

Equipment supplied with Combustion Engine

- Never inhale exhaust fumes as this can be harmful to your health;
- The Carbon monoxide from the exhaust of internal combustion engines can cause death if used in confined spaces;
- Do not operate or refuel the gasoline or diesel engine in a confined space without sufficient ventilation;
- Do not fuel the equipment when the engine is hot, this could become very dangerous and ensure that there is sufficient ventilation during this procedure;
- Do not touch the engine when it is running as it can burn your skin;
- Use fuel according to engine model;
- Do not use fuel of doubtful origin;
- To prevent electric shock, never touch the spark plug while the engine is running;
- The correct use, cleaning and maintenance of combustion engines must always be in accordance with the instructions contained in the manual of the engine manufacturer.

Operation Conditions

- Concrete mixers can be used in both indoor and outdoor environments;
- When filling a concrete mixer with a spade, do not place the spade inside the drum;
- Improper use of this equipment, other than that for which it was projected, can pose a physical threat to the operator;
- Read this instruction manual carefully;
- The operator must be trained or qualified to use this equipment;
- Set aside an exclusive area for working with the equipment. Keep this area clear of obstacles and well lit at all times;
- Whenever performing maintenance on this equipment, disconnect the cable from the power supply.
- Pneumatic wheel rim 13" calibration: between 26 and 30 p.s.i (pound force per square inch);

Noise level during operation:

Since the noise level during mixer operation, with the addition of stone and gravel into the drum to simulate a maximum noise level, can reach up to 95 decibels, the use of ear protection is recommended during prolonged operation.

Cleaning and Conservation

- It must be disconnected from the mains and the cleaning operation is always performed at the end of utilization;
- Cleaning the drum with water, removing any residue of the blades and all internal and external part of the drum;
- Clean the rack and pinion, removing all abrasive material to components;
- Do not put water on electrical components and engine;

Grounding the Equipment

- Correct grounding of the concrete mixer is vitally important in reducing the risk of electrical shocks;
- Thus, before switching on your concrete mixer, make sure that the socket has an ground pin and that this is correctly installed. If your socket is not grounded, arrange for an ground to be installed before using the concrete mixer;
- Should use copper rod length and recommended depth of 2 meters;
- The ground wire to pass through the on / off switch should not be interrupted or connected to contacts.
- Do not connect the ground wire directly into the mixer neutral wire mains.
- Grounding must be made according to the standards in the region and accompanied by a responsible qualified function. In the absence of such standards, should be carried out according to international standards, doubts when the installation please contact your authorized service;

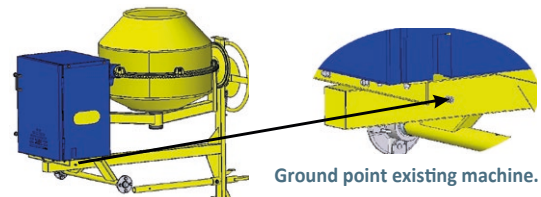

Equipment Lubrication

- Keep machine rotating parts lubricated, such as: pinion, rack gear, bushings, and bearings;
- Lubricate the equipment at the beginning of operation, applying grease to all lubrication points;
- Lubrication of the pinion/rack gear assembly is not recommended due to the fact that aggregates such as sand, cement and gravel dust, among others, can adhere to the lubricating agent, causing the mixture to become extremely abrasive, thus resulting in premature wear.
- When lubricating the pinion shaft bearing, the concrete mixer drum must be in a position where the steel yoke arm is perpendicular (90°) in relation to the machine column and the drum mouth must be turned to the same side where the grease fitting is. If not, the bearings will not be lubricated;

Recommended Greases

Esso: Beacon 2

Mobil: Mobilux 3

Shell: Shell Avania R2

Texaco: MultiFlax EPO

Castrol: Graxa LM2

Atlantic: Litholine 2

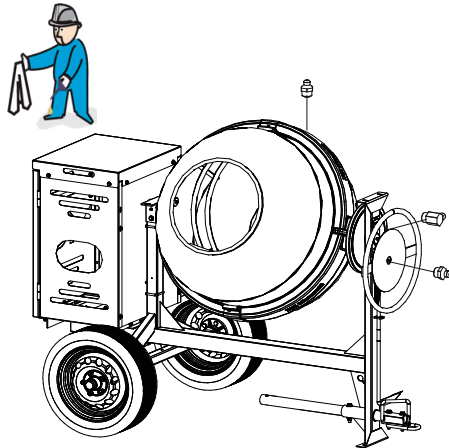

Transport, Lifting and Towing

- It has yoke just to raise a few centimeters of soil and carry through the movement of the wheels;
- They should be used by tilting, with the barrel facing down, while maintaining the flatness of the mixer;

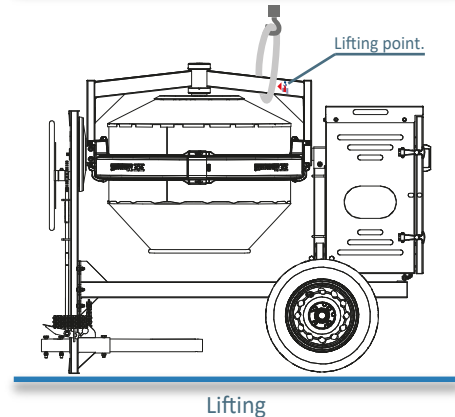
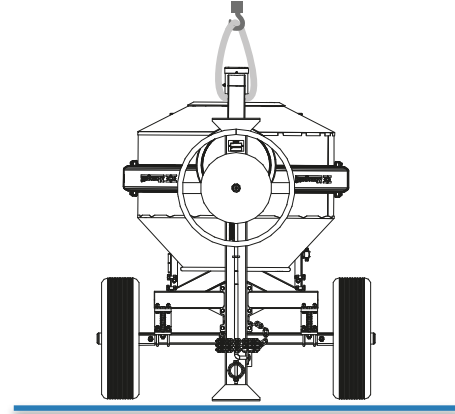

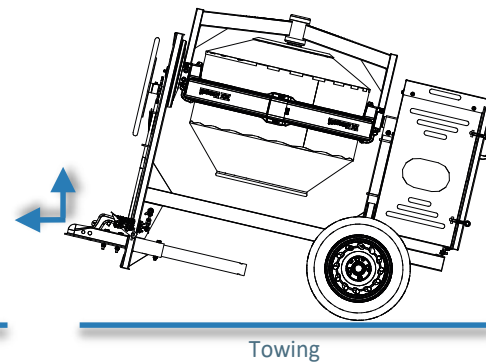
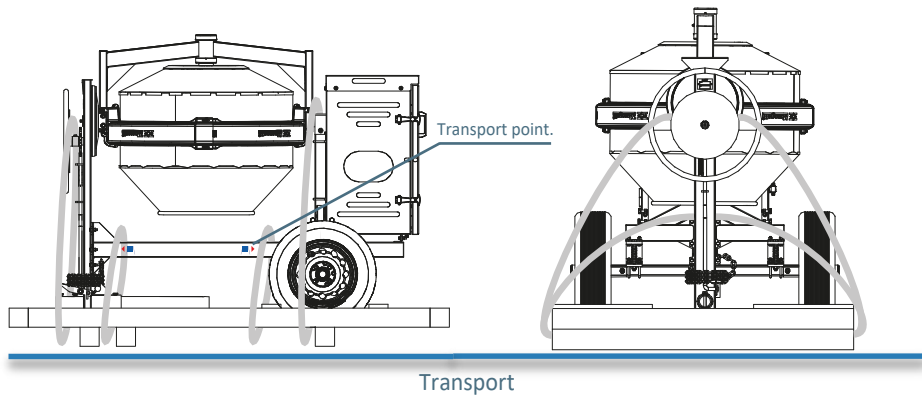

Wiring Diagram

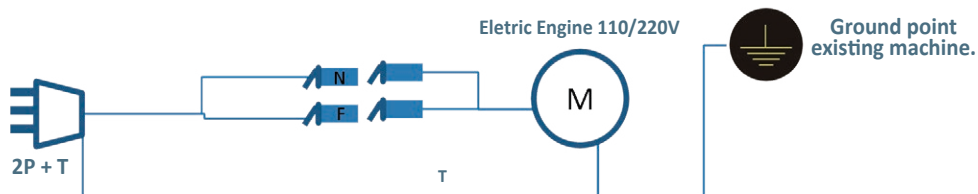
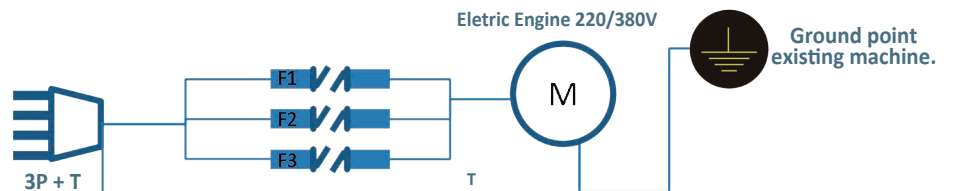

Equipment Operation

- Position the mixer on a flat, firm surface, so that facilitates the process of loading and unloading;
- Turn the switch that is attached to the engine enclosure;
- tilting the drum to the desired angle. This movement should be done by turning the steering wheel and at the same time stepping on the pedal, unlocking the swivel rocker;
- Set the desired angle and lock again, this movement occurs when the pedal is released;
- Load the drum and let blending;
- Once the mixture, tilting the drum to dump all the dough;
- Throughout the cycle the drum must be spinning or whatever equipment is always on;



1. Make use of a measure (bucket) to quantitate the components.



2. Add the aggregate (gravel) in the cement mixer on.



3. Make use of a measure (bucket) to quantitate the components.



4. Add the cement.



5. Finally add the sand and the rest of the water.



6. Let the concrete mixer rotate for 2,5 minutes before using the concrete.

Equipment Maintenance

Rack Gear Replacement

- Remove the damaged rack gear screws (07), and replace them according to assembly recommendations;
- Use two $\varnothing 5$ mm pins (C) to adjust the gap between teeth, necessary for the perfect running of the pinion and rack gear;
- Adjust the alignment between the rack gear and pinion by reference face "A", (07) (42) compensating the difference with flat washers;

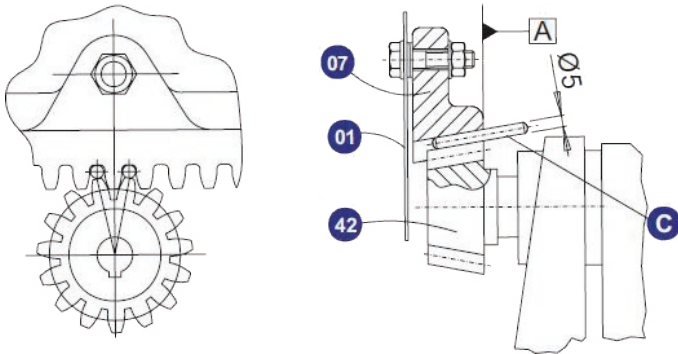

Assembly Procedures

Check List

Check list - Concrete mixer	Check list - Concrete mixer		
Chassi	1	Motor support	2
Chassi motor support	1	Pulley	1
Wheel rubber solid	2	Top cover	1
Tow bar	1	Left side of the box	1
Steering wheel	1	Right side of the box	1
Steel yoke	1	Upper end of the box	1
Bearing support	1	Box door	1
Drum	1	Motor pulley	1
Lower guide	1	Belt V - A	2
Larger guide	1		

1) Assemble the steering wheel (1) on the pinion shaft (2), and fasten with self-locking hexagonal nut 3/4" (3). Assemble the tow bar (4) on chassi (5) with hexagonal bolt 1/2"x 3.1/2 (6).

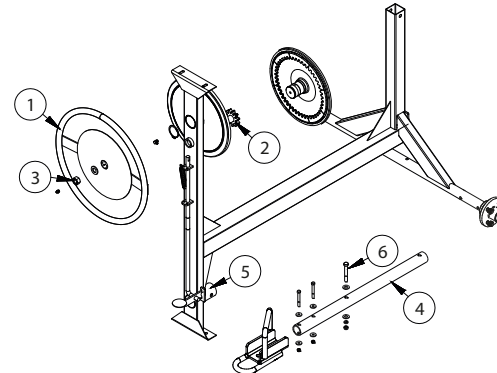

2) Assemble the chassi motor support (1) on lower column (2), fasten with the hexagonal bolt $3/8'' \times 1''$ (3). Then, fasten the lower guide (4) and larger guide (5) on the chassi motor support (1) with hexagonal bolt $3/8'' \times 1''$ (3). Fasten the motor support (6) on guides with hexagonal bolt $3/8'' \times 2''$ (7).

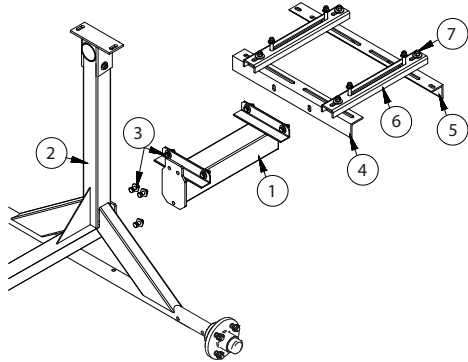

3) Assemble the steel yoke (1) on reducer (2) with hexagonal bolt $3/8'' \times 4.1/2''$ (3). Assemble the bearing support (4) on the steel yoke (1) and fasten on the lower column (5) with bolt $3/8'' \times 3.1/2''$ (6).

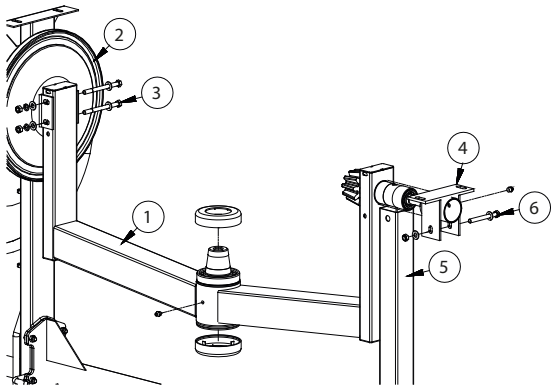

4) Position the steel yoke (1) in 30° angle. Place the drum (2) on the steel yoke (1) and tightening the hexagonal bolt $7/8'' \times 2.1/4''$ (3).

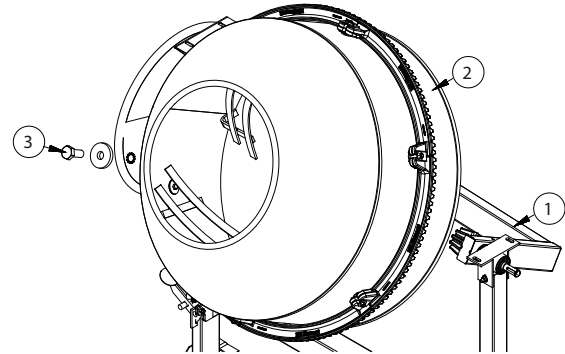

5) Assemble the motor box. Fix the upper end (1) in the lower column (2) with U-bolt (3). Then assemble the sides (4) and the top cover (5), fasten with hexagonal bolt $5/16'' \times 3/4''$ (6). Assemble the door (7).

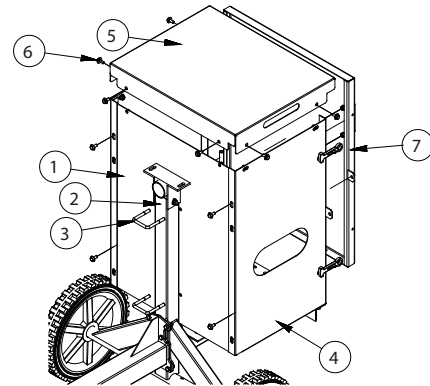

6) Fit pulley (1) on the pinion shaft (2), securing with retaining ring E-20 (3) and key 6x6x30.

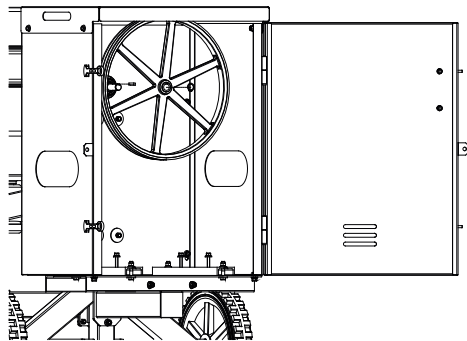

7) Complete assembly.

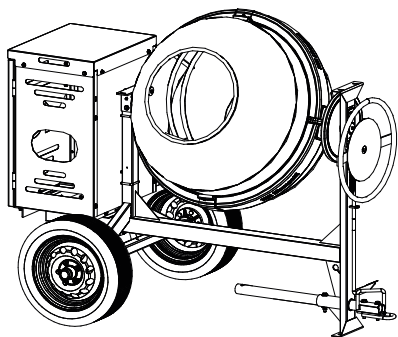

Characteristics



	CONCRETE MIXER	PROFESSIONAL 11 CuFt	PROFESSIONAL 7 CuFt
1	DIFFERENTIAL PAINTING	BLUE	BLUE
2	DRUMS BODY	THICKNESS 2,65 mm	THICKNESS 2,65 mm
3	DRUMS CONE	THICKNESS 1,9 mm	THICKNESS 2,65 mm
4	CHASSIS TUBE	THICKNESS 2,0 mm	THICKNESS 2,0 mm
5	WHEEL	WHEEL 13	WHEEL 13
6	WARRANTY	12 MONTHS	12 MONTHS

Parts List

Motor Box 7/11 CuFt

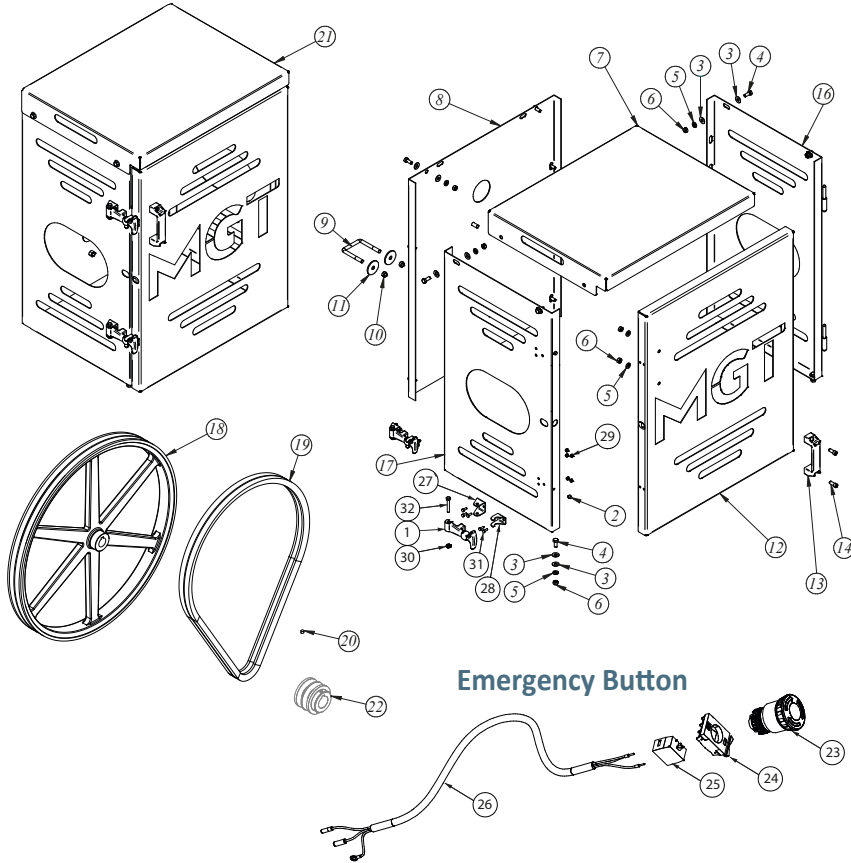

Emergency Button

POS.	DESCRIPTION	QTY.	CODE	DRAWING
1	Rubber Door Latch	2	24030255	4122581
2	Stop Rubber	2	24030222	4122072
3	Flat Washer 5/16"	23	21030252	-
4	Hex. Bolt 5/16"x3/4"	12	21010268	-
5	Spring Washer 5/16"	14	21030112	-
6	Hex Nut 5/16"	14	21021052	-
7	Top Cover	1	33108299	3108299
8	Back Side Box	1	32420077	3108373
9	U-Bolt 3/8"	2	21012480	4108003
10	Hex Nut 3/8" UNC	4	21021059	21021059
11	Flat Washer	4	30100070	4107003
12	Door Box	1	33108433	3108433
13	Handle	1	24070164	4122435
14	Hex. Bolt 5/16"x3/4"	2	21010523	-
16	Right Side	1	23108437	3108437
17	Left Side	1	23108435	3108435
18	Pulley Ø450MM	1	29112206	3108301
19	V-Belt	2	-	-
20	Bolt 1/4" X 1/4"	2	21010919	-
21	Motor Box (Blue box)	1	35400205	3108438
22	Pulley Ø60mm - 11CuFt	1	31090268	4109069
	Pulley Ø60mm - 7CuFt	1	31090270	4109070
23	Emergency Button	1	26160132	-
24	Flange (Emergency Button)	1	26160155	-
25	Contact Block NA BC10F-CSW X100	1	26160146	-
26	Cable (Emergency Button)	1	26010436	4122579
27	Fixed Rubber Door Latch Support	2	29117877	4122582
28	Movable Rubber Door Latch Support	2	29117878	4122583
29	Hex Nut 3/16"	10	21021002	-
30	Low Hex Nut 1/4"	2	21021004	-
31	Hex. Bolt 3/16"x 1/2"	10	29117880	-
32	Hex. Bolt 1/4"x 1.3/4"	2	29117879	-

Steel Yoke 11 CuFt

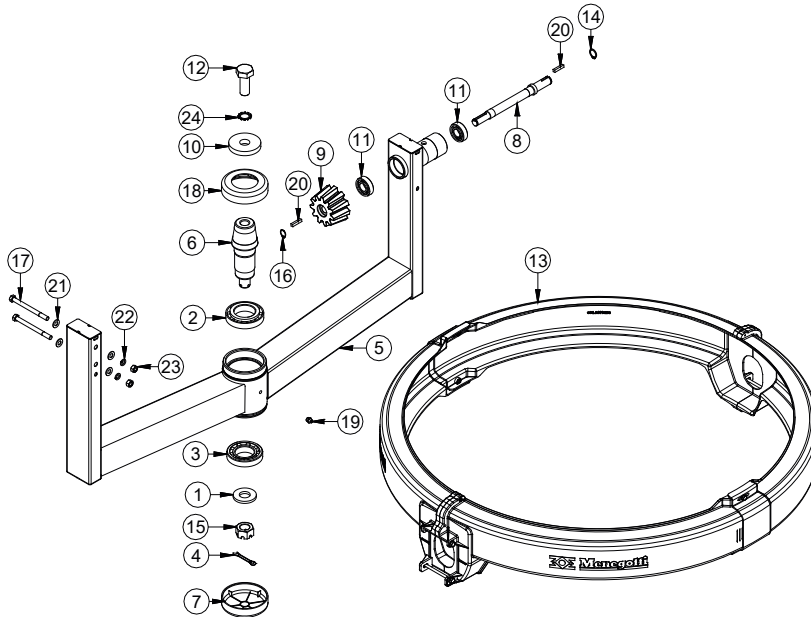

POS.	DESCRIPTION	QTY.	CODE	DRAWING
1	Flat Washer DN26	1	30100079	4122006
2	Bearing 30210	1	22020608	-
3	Bearing 30209	1	22020607	-
4	Cotter Pin 3/16"X1.1/2"	1	21050106	-
5	Steel Yoke 400L Professional	1	32460056	3106047
	Steel Yoke 400L Rental	1	32460057	3106049
6	Central Axis	1	3114039	3114039
7	Cover	1	24110102	4122007
8	Pinion Shaft	1	31020026	3114002
9	Pinion Z-11	1	31030007	4123001
10	Drum Washer	1	21030232	4122008
11	Bearing 6204	2	22020206	-
12	Hex Bolt 7/8"x 2.1/4"	1	21013442	-
13	Rack Gear Protection	1	32030067	3119147
14	Elastic ring E-20	1	21060118	-
15	Castle Nut 1"	1	21020959	-
16	Elastic ring E-17	1	21060115	-
17	Hex Bolt 3/8"x 4.1/2"	2	21010250	-
18	Cover with Hole	1	24110168	4122183
19	Grease fitting 1/8" Straight	1	24040101	-
20	Key 6X6X30MM	2	30160002	4122009
21	Flat Washer 3/8"	4	21030251	-
22	Spring Washer 3/8"	2	21030163	-
23	Hex Nut 3/8"	2	21020117	-

Drum 11 CuFt

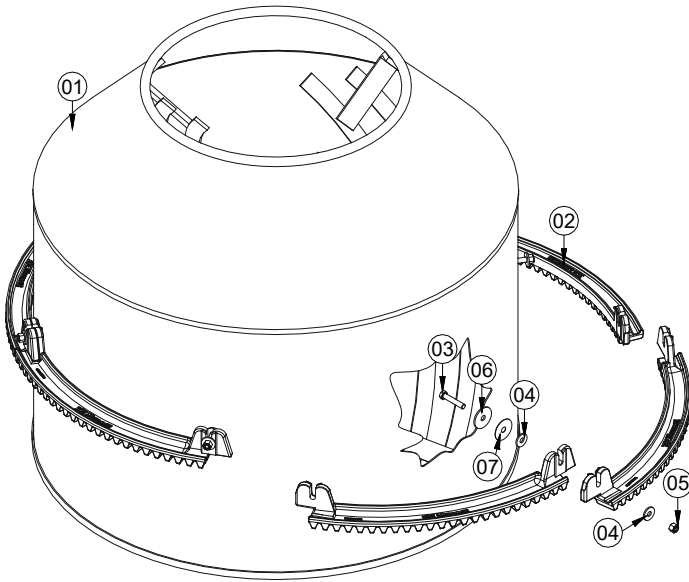

POS.	DESCRIPTION	QTY.	CODE	DRAWING
1	Drum 400L Professional	1	34600034	2107002
	Drum 400L Rental	1	34600038	2107004
2	Segmented Crown Rack Gear	6	31180004	2124011
3	Hex Bolt 3/8"X2"	6	21010241	-
4	Flat Washer 3/8"	12	21030230	-
5	Hex Nut 3/8"	6	21021059	-
6	Drum Washer	6	30100070	4107003
7	Sealing Washer	6	30100114	4107002
POS.	DESCRIPTION	JG.	CODE	DRAWING
2 ao 7	Rack Gear Segmented (segmented, washer, nut, bolt)	1	31180013	2124020

Rack Gear Protection 11 CuFt

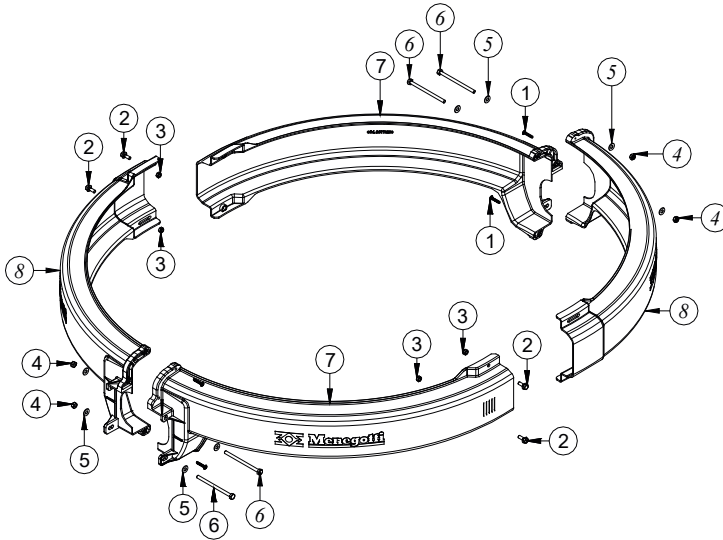

POS.	DESCRIPTION	QTY.	CODE	DRAWING
1	Screw M5x25mm	4	21011022	-
2	Hex Bolt M6x16mm	4	21012986	-
3	Hex Nut M6	4	21021208	-
4	Hex Nut 1/4"	4	21021004	-
5	Flat Washer 1/4"	8	21030214	-
6	Hex Bolt 1/4"X4"	4	21010184	-
7	Right - Rack Gear Protection	2	24110200	3119146
8	Left - Rack Gear Protection	2	24110199	3119145
10	Left - Pinion Protection	1		

Chassi 11 CuFt

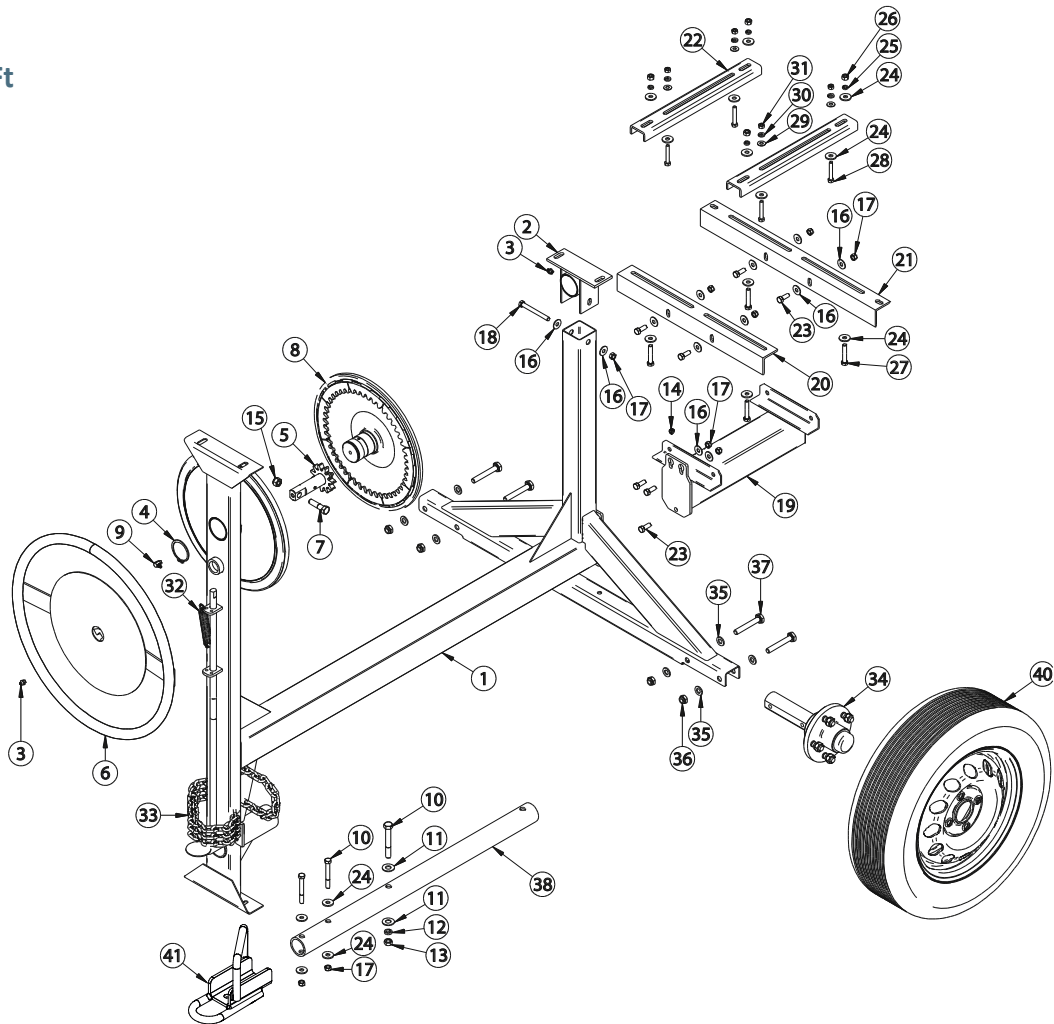

POS.	DESCRIPTION	QTY.	CODE	DRAWING
1	Chassi 400L Professional	1	-	2105084
2	Bearing support	1	31140055	3116001
3	Grease Fitting 1/8" Straight	2	24040101	-
4	Retaining Ring E-54	1	21060146	-
5	Shaft with Gear Z-11 Rental	1	31020461	4114087
6	Steering Wheel 400L Rental	1	31200017	3122170
7	Hex Bolt 1/2"x2" BSW	1	21010313	-
8	Reducing	1	31220021	3121004
9	Grease Fitting 1/8"	1	24040105	-
10	Hex Bolt. 1/2" X 3 1/2"	3	21010433	-
11	Flat Washer Ø30 X Ø13 X 2,0mm	6	21030250	-
12	Spring Washer 1/2"	1	21030164	-
13	Hex Nut 1/2" BSW	1	-	-
14	Hex Nut 1/4"	1	21021004	-
15	Hex Nut 1/2" BSW	3	21021070	-
16	Washer 3/8"	13	21030251	-
17	Hex Nut 3/8" UNC	8	21021059	-
18	Hex Bolt 3/8" X 3.1/2"	1	21013826	-
19	Chassi Motor Support	1	-	3125117
20	Lower Guide 500mm	1	32180017	3112012

POS.	DESCRIPTION	QTY.	CODE	DRAWING
21	Larger Guide 600mm	1	32180016	3112011
22	Motor Suport X 400mm	2	32060144	3112013
23	Hex Bolt 3/8"x1" UNC	7	21010266	-
24	Thick Flat Washer 3/8"	12	21030230	-
25	Spring Washer 3/8"	4	-	-
26	Hex Nut 3/8"	4	21020117	-
27	Hex Bolt 3/8" X 2"	4	-	-
28	Hex Bolt 5/16"X2"	4	21010228	-
29	Flat Washer 5/16"	4	21030252	-
30	Spring Washer 5/16"	4	21030112	-
31	Hex Nut 5/16"	4	21021052	-
32	Traction Spring	1	21090116	-
33	Short link chain 1-4 inch	1	22060303	-
34	Rub Wheel	2	3137123	3137123
35	Flat Washer M12 (13x24x2,5)	8	29110907	-
36	Hex Nut BX M12x1,75 DIN985 ZB	4	21021207	-
37	Hex Bolt M12 x 85mm	4	21012983	-
38	Tow Bar Ø 2" x 800 mm	1	-	4110104
40	Pneumatic Wheel Rim A13"	1	31260050	4115011
41	Trailer Coupling	1	3122537	3122537

Drum 7 CuFt

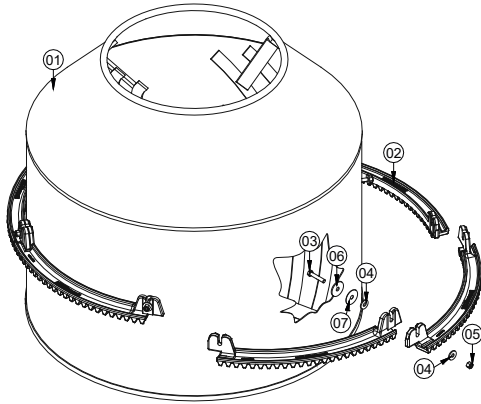

POS.	DESCRIPTION	QTY.	CODE	DRAWING
1	Drum 250 Professional	1	34600053	3.107.023
2	Segmented Crown Rack Gear	6	31180116	2.124.024
3	Hex Bolt 3/8"X2"	6	21013820	-
4	Flat Washer 3/8"	12	21030230	-
5	Hex Nut 3/8"	6	21021059	-
6	Drum Washer	6	30100070	4.107.003
7	Sealing Washer	6	30100114	4.107.002

Rack Gear Protection 7 CuFt

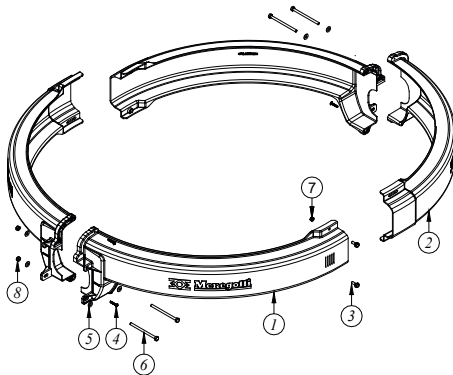

POS.	DESCRIPTION	QTY.	CODE	DRAWING
1	Right - Rack Gear Protection	2	24110159	3.119.153
2	Left - Rack Gear Protection	2	24110149	3.119.154
3/4	Hex Bolt M6x16mm	10	21012986	-
5	Flat Washer 1/4"	8	21030214	-
6	Hex Bolt 1/4"X4"	4	21010184	-
7	Hex Nut M6	10	21021104	-
8	Hex Nut 1/4"	4	21021004	-

Chassi 7 CuFt

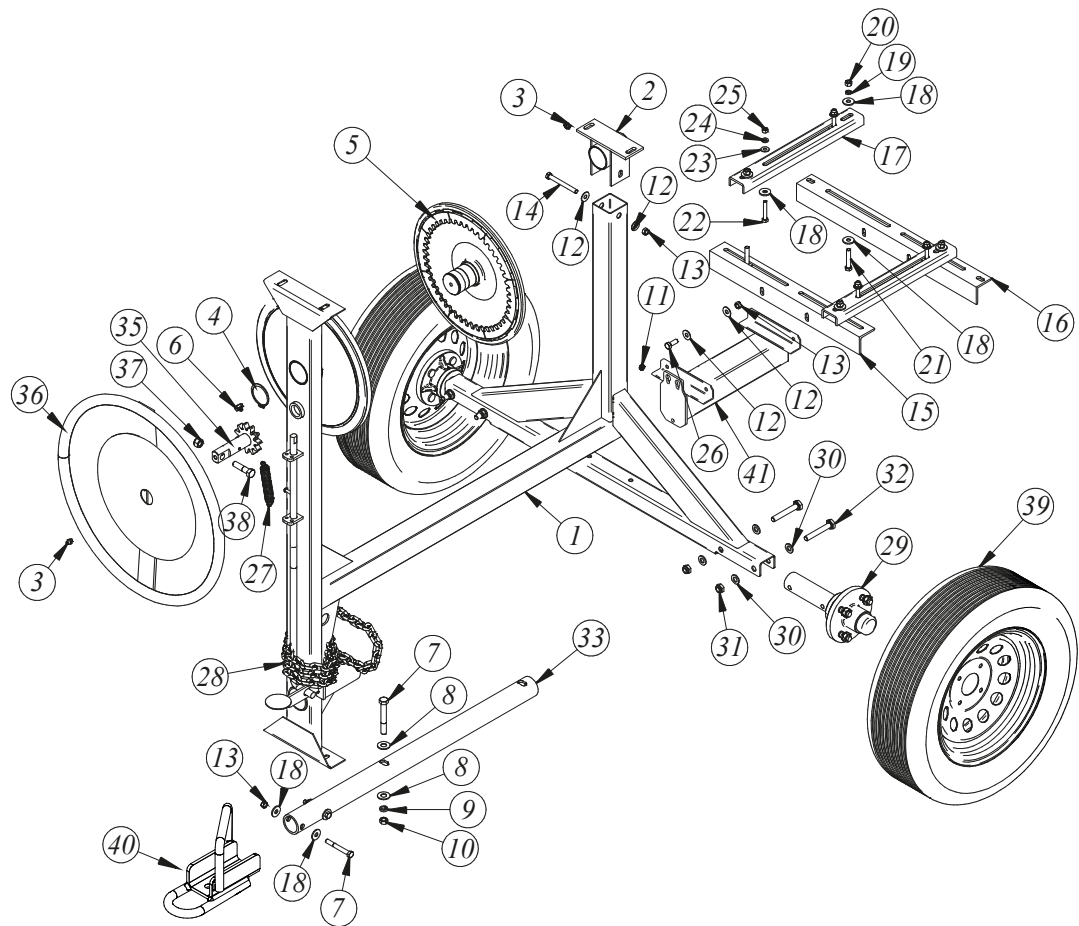

POS.	DESCRIPTION	QTY.	CODE	DRAWING
1	Chassi 250 Professional	1	-	3105044
2	Bearing support	1	31140055	3116001
3	Grease Fitting 1/8" Straight	2	24040101	-
4	Retaining Ring E-54	1	21060146	-
5	Reducing	1	31220021	3121004
6	Grease Fitting 1/8"	1	24040105	-
7	Hex Bolt. 1/2"x3.1/2"	3	21010433	-
8	Flat Washer Ø30 X Ø13 X 2,0mm	6	21030250	-
9	Spring Washer 1/2"	1	21030164	-
10	Hex Nut 1/2" BSW	1	21020207	-
11	Hex Nut 1/4"	1	21021004	-
12	Washer 3/8"	10	21030251	-
13	Hex Nut 3/8" UNC	5	21021059	21021059
14	Hex Bolt 3/8" X 3.1/2"	1	21013826	-
15	Lower Guide 500mm	1	32180017	3112012
16	Larger Guide 600mm	1	32180016	3112011
17	Motor Suport X 400mm	2	32060144	3112013
18	Thick Flat Washer 3/8"	12	21030230	-
19	Spring Washer 3/8"	4	21030163	-
20	Hex Nut 3/8"	4	21020117	-

POS.	DESCRIPTION	QTY.	CODE	DRAWING
21	Hex Bolt 3/8" X 2"	4	21010241	-
22	Hex Bolt 5/16"X2"	4	21010228	-
23	Flat Washer 5/16"	4	21030252	-
24	Spring Washer 5/16"	4	21030112	-
25	Hex Nut 5/16"	4	21021052	-
26	Hex Bolt 3/8"x1" UNC	4	21010266	21010266
27	Traction Spring	1	21090116	-
28	Short link chain 1-4 inch	1	22060303	22060303
29	Rub Wheel	2	3137159	3137159
30	Flat Washer M12 (13x24x2,5) DIN125	8	29110907	-
31	Hex Nut BX M12x1,75 DIN985 ZB	4	21021207	-
32	Hex Bolt M12 x 85mm	4	21012983	-
33	Tow Bar Ø 2" x 800 mm	1	-	4110104
35	Shaft with Gear Z-11	1	31020461	4114087
36	Steering Wheel 250L Professional	1	-	3122170
37	Hex Nut 1/2" BSW	3	21021070	-
38	Hex Bolt 1/2"x2" BSW	1	21010313	-
39	Wheel Rim A13"	2	-	-
40	Trailer Coupling	1	3122537	3122537
41	Chassi Motor Support	1	4125065	4125065

Product Warranty

The conditions and terms of this warranty are non transferable and go into effect on the date of purchase of this equipment, proven by presentation of the sales invoice issued to the first end user. At the time of delivery of the equipment, the customer must be provided with the information and technical orientations according to the contents of this manual.

Not, however, included in this warranty are defects arising from improper use, negligence, imprudence or malpractice, nor are repairs or alterations to any part and/or component of the equipment. Also not included are: the assembly of any sets of parts by technicians not from the Factory itself or from an Authorized Technical Assistant, application other than which it was specified, mechanical or electrical overloading as well as lack of phase, use in environments for which it was not designed, incorrect voltages and frequencies, incorrect lubrication, damage caused by accidents of any nature, such as floods, gales, fire, landslides or due to transportation.

Removal or any alteration to the series numbers originally placed on the product will render the warranty null, where the Sales invoice and Warranty Certificate must be presented in relation to the equipment in question.

This warranty is limited to the repair, replacement of parts or assembly of parts in which, through examination by a Menegotti Authorized Technical Assistant with prior authorization from the Factory, any manufacturing defect will be verified. This repair or replacement will be performed by the authorized Technical Assistant, where the purchaser will be responsible for risks and expenses arising from transport to and from the authorized Technical Assistant, and where labor and parts will not be charged according to the terms of this warranty.

This warranty replaces any other warranty, implicit or explicit, as well as all any obligation or responsibility on the part of our company in relation to the above mentioned product.

MENEGOTTI Post Sales Department and Technical Assistance.

Term of Warranty

By the present CERTIFICATE provided from original purchaser, Menegotti guarantees this product against manufacturing defects, for a period of 12 (twelve) months, counted from the invoice issue date of the first final consumer. This equipment's warranty does not include components worn out by use, such as: bearings, steel cable, electrical plugs, gears and engine breaking.

This warranty includes the replacement of parts and repairs due to manufacturing defects duly noted by the factory or Authorized Technical Assistant. This warranty will be rendered null and void in the case of damages arising from accidents, acts of nature, application other than which it was designed, connection to improper electrical supply or subjected to extensive power fluctuations, or, if opened by persons or workshops not authorized by Menegotti.

The consumer will be responsible for freight expenses for transporting the product to the technical assistant or factory. The equipment includes and electric motor and this warranty covers internal defects in the motor originating from its manufacture. Defects not covered in this warranty include: overloading due to lack of or excessive phase, use of voltage outside that specified, broken or crushed casing due to negligence during transporting /or storage, coupling or energizing outside specifications and general defects from improper use and/or incorrect installation.

In agreement with these terms,

Customer: _____
Model: _____ **Serial Number:** _____
City: _____ **Date:** _____

Customer

Menegotti Authorized Service



Menegotti

GROUP

Solid values, *sustainable future.*

MENEGOTTI
HANDLING

MENEGOTTI
CONSTRUCTION

MENEGOTTI
HOUSE & GARDEN



Unit • Unidat Menmaq

Erwino Menegotti, 381 - Água Verde
Jaraguá do Sul - SC - 89254-000



Unit • Unidat Mentec

José Theodoro Ribeiro, 2399 - Ilha da Figueira
Jaraguá do Sul - SC - 89258-468



Unit • Unidat Menfer

Saudade, 186 - Seminário
Corupá - SC - 89278-000



Unit • Unidat MNA

248 E Crogan St STE 301 - Lawrenceville - GA
30046 - United States

grupomenegotti.com