

Aerators, Core

CA25 Series

Description	CA2560	CA2572
Working Width	60"	72"
Overall Width	68 3/4"	79 3/4"
Overall Length	30 1/4"	
Overall Height (With support stands up)	42"	
Weight (w/o added weight)	464#	480#
Number Of Spoons	96	96
Spoon Material	3/4" Closed case hardened Replaceable.	
Spoon Spacing in forward travel	7"	
Spoon Penetration	4 1/2" Depending on ground conditions and added weight.	
Gang Spacing	5 1/2"	6 1/2"
Number of Gangs	12	12
Frame Construction	Tubing 2 1/2" x 2 1/2" x 3/16"	
Hitch	Cat. 1	
Quick Hitch	Fits Land Pride's Model QH15 Quick Hitch (Upper hitch of Quick Hitch will need to be raised up to fit.)	
Support Stands	Support stands in all four corners	
Water Tank Capacity (gallons per tank)	29 gallons per tank	36 gallons per tank
Full Water Tank Weight (2-tanks)	490 lbs. Total weight	600 lbs. Total weight

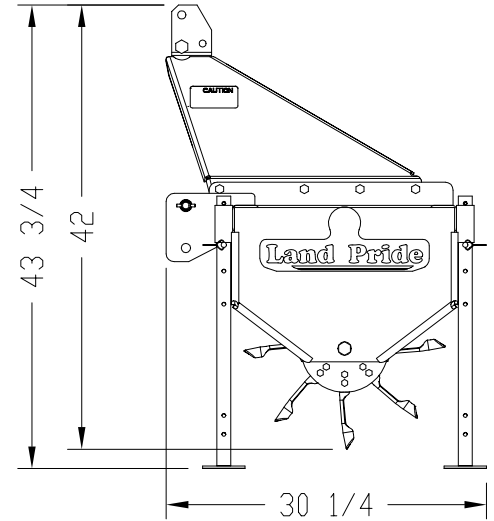
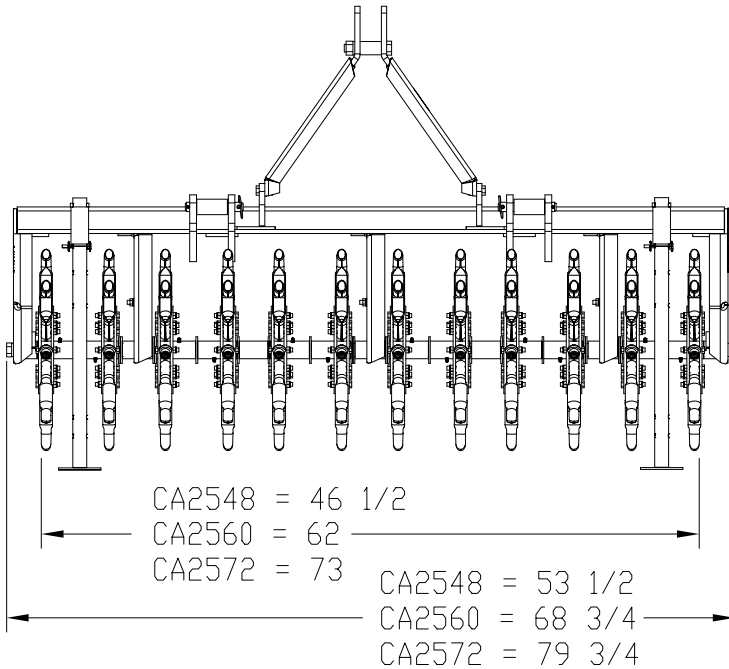

26738

Designs, specifications, features and information are subject to change without notice.