



[Click Here To View](#)
[Item at](#)

www.GapPower.com

Sales • Rentals
Parts & Service



REVISED APRIL 2011

**NIGHT LITE PRO
50-60 Hz SERIES
OPERATOR'S
MANUAL**

ALLMAND BROTHERS INC.

P.O. BOX 888

HOLDREGE, NE 68949

PHONE: (308) 995- 4495, 1- 800- 562- 1373

ALLMAND FAX: (308) 995- 5887

ALLMAND PARTS DEPT. FAX : (308) 995- 4883

www.allmand.com

NIGHT LITE PRO 50-60 Hz SERIES

**California
Proposition 65 Warning**

Diesel engine exhaust and some of its constituents are known to the State of California to cause cancer, birth defects, and other reproductive harm.

**California
Proposition 65 Warning**

Battery posts, terminals, and related accessories contain lead and lead compounds, chemicals known to the State of California to cause cancer and reproductive harm.
Wash hands after handling.

RECORD IMPORTANT INFORMATION

Company Equipment No.: _____

Unit Model No.: _____

Unit VIN: _____

Engine Model No.: _____ **Serial No.:** _____

Generator Model No.: _____ **Serial No.:** _____

Accessories: _____

TABLE OF CONTENTS

5/24/2011

Introduction

About this Manual.....7

Safety

Safety Definitions.....8

Safety Precautions.....8

Trailing, Transporting and Lifting

Preparing the Unit for delivery or Rental.....13

Check list.....13

Before Trailing / Transporting.....15

 Shutdown - Prepare for Trailing.....16

 Tower Lights - Stowage for Trailing.....17

 Tower Lights - Removal for Trailing (optional).....18

Trailing / Towing.....19-21

 Trailer Component Identification.....19

 Towing Vehicle and Hitch Considerations.....20

 Connecting the Trailer Hitch Coupler and Lights.....20-21

Lifting the Light Tower.....22

Transporting on a Trailer.....22

General Service Information

Equipment Identification.....23

Models and Serial Numbers.....24

 Trailer.....24

 Generator.....24

 Engine.....25-26

TABLE OF CONTENTS

5/24/2011

Specifications (Standard and optional Features).....	27-31
Trailer.....	27
Overall Dimensions.....	28
Light Tower.....	28
Generator.....	28
Tower Lights.....	29
Engine.....	30
Optional Accessory Equipment.....	31

Operation

Pre - Operation Setup.....	32
Work Site Safety Considerations.....	32
Pre-Operation Check list.....	32
Leveling and Stabilizing the Trailer.....	33
Installing the Ground Rod.....	34
Engine Operation.....	34-36
Pre-Start Checks.....	34
Engine Control Panels.....	35-37
Starting the Engine.....	38
Stopping the Engine.....	38
Automatic Engine Shutdown System.....	38
Tower and Light Operation.....	38
Light Bar and Light Fixture Adjustment.....	39
Raising and Lowering the Light Tower.....	39
Light Control Panel.....	41

TABLE OF CONTENTS

5/24/2011

Shutdown Procedure.....	41
Shutdown-Short Period.....	41
Shutdown Long-Term or Prepare for Trailering.....	41
Auxiliary AC Outlet Operation.....	41
Convenience Panel.....	42

Maintenance

Engine.....	43
Changing and Adding Engine Oil.....	43
Engine Filters.....	43
Electrical System.....	43
Ballast Panel.....	43-44
Light Tower and Lamps.....	45
Changing Lamps.....	45
Tower corner Guide Block Adjustment.....	46
Trailer.....	46
Frame.....	46
Grease Points.....	46
Trailer Wheels And Tires.....	46-47
Wheel Bearings.....	47
Trailer Lighting.....	48
Long-Term Storage.....	48
Cleaning.....	49
Cleaning and Draining the Trailer Bilge.....	49

TABLE OF CONTENTS

5/24/2011

Troubleshooting

Troubleshooting Chart.....	50
Maintenance Record.....	51

Wiring Schematics

Kohler KDW 1003 Wiring Diagram.....	52-53
Cat C1.1 Wiring Harness.....	54
Kubota Wiring Diagram.....	55-56
SHO-HD lighting System 240V - 1000W.....	57
SHO-HD Lighting System 240V -1250W.....	58-59
Light Bar 14/7 Cord.....	60
Tail Lamp Wiring.....	61

Warranty

Parts Book

Congratulations on the purchase of your new Allmand NIGHT LITE PRO light towers and welcome to the Allmand family of equipment owners.

The Allmand NIGHT LITE PRO light towers offers many advantages to make operation safer, more convenient and more cost-effective. The NIGHT LITE PRO II light towers will provide you with high-quality performance and durability which translates into more productivity on the job site.

ABOUT THIS MANUAL

Take time to read this manual thoroughly.

This *Operator's Manual* provides information necessary for the safe operation of the Allmand Bros. Inc. NIGHT LITE PRO light towers.

NOTICE: Keep this manual accessible during operation to provide convenient reference. Store this manual in a safe place for future reference.

If you are uncertain about any of the information in the manual, contact Allmand or your Allmand dealer for clarification before operation.

Specific operating instructions and specifications are contained in this publication to familiarize the operator and maintenance personnel with the correct and safe procedures necessary to maintain and operate the equipment.

Engine— specific operating instructions and specifications are contained in the engine owner's manual provided in your owner's kit. Always refer to engine owner's manual for operation and maintenance procedures.

The graphics and text in this manual generally describe the Allmand NIGHT LITE PRO 50 - 60Hz light towers. Allmand light tower differ by model and optionally installed equipment. Your Allmand light tower may not exactly match the graphics and /or text descriptions in this manual.

NOTICE: The information found in this manual was in effect at the time of printing. Allmand Bros. may change contents without notice and without incurring obligation.

NOTICE: Any reference in this manual to left or right shall be determined by looking at the trailer from the rear.



SAFETY DEFINITIONS

Safety statements are one of the primary ways to call your attention to potential hazards. Follow the precautions listed throughout the manual before operation, during operation and during periodic maintenance procedures for your safety, the safety of others and to protect the performance of the equipment. Keep the decals from becoming dirty or torn and replace them if they are lost or damaged. Also, if a part needs to be replaced that has a decal attached to it, make sure to order the new part and decal at the same time.



This safety alert symbol appears with most safety statements. It means attention, become alert, your safety is involved! Please read and abide by the message that follows the safety alert symbol.

DANGER

Indicates a hazardous situation which, if not avoided, **will** result in death or serious injury.

WARNING

Indicates a hazardous situation which, if not avoided, **could** result in death or serious injury.

CAUTION

Indicates a hazardous situation which, if not avoided, **could** result in minor or moderate injury.

NOTICE

Indicates a situation which can cause damage to the equipment, personal property and/or the environment, or cause the equipment to operate improperly.

Note: Provides key information to make procedures easier or clearer.

SAFETY PRECAUTIONS

There is no substitute for common sense and careful practices. This information contains general safety precautions and guidelines that must be followed to reduce risk to personal safety. Special safety precautions are listed in specific procedures. Read and understand all of the safety precautions before operating or performing repairs or maintenance. This safety section cannot cover every situation that may occur that is incidental to the use of the equipment. Use common sense if you encounter a situation that is not covered to help avoid a hazardous situation.

Refer to the *Engine Operator's Manual* and *Generator Operator's Manual* for additional safety precautions.

DANGER

The safety messages that follow have **DANGER** level hazards.

Electrocution Hazard



- Always check for overhead wires and obstructions before raising or lowering the light tower. Allow 35 feet (10.6 m) of clearance.
- High voltage is present when engine is running. Never attempt to service electrical components while engine is running.
- Do not operate the light tower if the insulation on the electrical cord or other electrical wiring is cut or worn, or if bare wires are exposed. Repair or replace damaged wiring before starting the engine.

⚠ WARNING

The safety messages that follow have WARNING level hazards.

Unsafe Operation Hazard

- Never permit anyone to install or operate the equipment without proper training.

- Read and understand this *Operator's Manual*, the *Engine Operator's Manual* and *Generator Operator's Manual* before operating or servicing the light tower to ensure that safe operating practices and maintenance procedures are followed.
- Safety signs and decals are additional reminders for safe operating and maintenance techniques.

Fall Hazard

Never carry riders on the equipment.

Modification Hazard

Never modify the equipment without written consent of the manufacturer. Any modification can affect the safe operation of the equipment.

Exposure Hazard

A0055010

Always wear personal protective equipment, including appropriate clothing, gloves, work shoes, and eye and hearing protection, as required by the task at hand.

Rollover Hazard

- Do not raise, lower or use light tower unless all outriggers and jacks are positioned on firm ground.
- Never move or reposition the light tower while the light tower is in the vertical position.

Explosion Hazard

- While the engine is running or the battery is charging, hydrogen gas is being produced and can be easily ignited. Keep the area around the battery well-ventilated and keep sparks, open flame and any other form of ignition out of the area.
- Always disconnect the negative (-) battery cable before servicing the equipment.
- Only use the starting procedure as described in the *Engine Operator's Manual* to start the engine.
- Never charge a frozen battery. Always slowly warm the battery to room temperature before charging.

Fire and Explosion Hazard

- Diesel fuel is flammable and explosive under certain conditions.
- Never use a shop rag to catch the fuel.
- Wipe up all spills immediately.
- Never refuel with the engine running.
- Store any containers containing fuel in a well-ventilated area, away from any combustibles or sources of ignition.

⚠ WARNING

The safety messages that follow have WARNING level hazards.

Exhaust Hazard

All internal combustion engines create carbon monoxide gas during operation and special precautions are required to avoid carbon monoxide poisoning:

- Never block windows, vents or other means of ventilation if the equipment is operating in an enclosed area.
- Always ensure that all connections are tightened to specifications after repair is made to the exhaust system.

Entanglement / Sever Hazard

- Always stop the engine before beginning service.
- If the engine must be serviced while it is operating, remove all jewelry, tie back long hair and keep hands, other body parts and clothing away from moving/rotating parts.
- Verify that all guards and covers are attached properly to the equipment before starting the engine. Do not start the engine if any guards or covers are not properly installed on the equipment.
- Attach a "Do Not Operate" tag near the key switch while performing maintenance on the equipment.

Alcohol and Drug Hazard

Never operate the light tower while under the influence of alcohol or drugs, or when ill.

Piercing Hazard

- Avoid skin contact with high-pressure hydraulic fluid or diesel fuel spray caused by a hydraulic or fuel system leak such as a broken hydraulic hose or fuel injection line. High-pressure hydraulic fluid or fuel can penetrate your skin and result in serious injury. If you are exposed to high-pressure hydraulic fluid or fuel spray, obtain prompt medical treatment.
- Never check for a hydraulic fluid or fuel leak with your hands. Always use a piece of wood or cardboard.

Flying Object Hazard

Always wear eye protection when cleaning the equipment with compressed air or high-pressure water. Dust, flying debris, compressed air, pressurized water or steam may injure your eyes.

Coolant Hazard

Wear eye protection and rubber gloves when handling engine coolant. If contact with the eyes or skin should occur, flush eyes and wash immediately with clean water.

⚠ WARNING

The safety messages that follow have WARNING level hazards.

Burn Hazard



- Light fixtures and some of the engine surfaces become very hot during operation and shortly after shutdown.

- Keep hands and other body parts away from hot engine surfaces.
- Handle hot components, such as light fixtures, with heat-resistant gloves.

⚠ CAUTION

The safety messages that follow have CAUTION level hazards.

Tool Hazard

Always use tools appropriate for the task at hand and use the correct size tool for loosening or tightening equipment parts.

Slip Hazard

- Immediately clean up any spilled liquid on the shop floor.
- Clean up accumulated dirt and debris on the shop floor at the end of each shift.

NOTICE

The safety messages that follow have NOTICE level hazards.

Any part which is found defective as a result of inspection or any part whose measured value does not satisfy the standard or limit must be replaced.

Always tighten components to the specified torque. Loose parts can cause equipment damage or cause it to operate improperly.

Only use replacement parts specified. Other replacement parts may affect warranty coverage.



Follow the guidelines of the EPA or other governmental agencies for the proper disposal of hazardous materials such as engine oil, diesel fuel and engine coolant. Consult the local authorities or reclamation facility.

Clean all accumulated dirt and debris away from the body of the equipment and its components before you inspect the equipment or perform preventive maintenance procedures or repairs. Operating equipment with accumulated dirt and debris will cause premature wear of equipment components. Accumulated dirt and debris also hinders effective equipment inspection.

Never dispose of hazardous materials by dumping them into a sewer, on the ground, or into groundwater or waterways.

Retrieve any tools or parts that may have dropped inside of the equipment to avoid improper equipment operation.

If any alert indicator illuminates during equipment operation, stop the engine immediately. Determine the cause and repair the problem before continuing to operate the equipment.

PREPARING THE NIGHT LITE PRO FOR DELIVERY OR RENTAL

The NIGHT LITE PRO light towers requires service as well as proper operation in order to provide the performance and safety it has been designed for. Never deliver or put machine into service with known defects or missing instructions or decals. Always instruct the customer in proper operation and safety procedures as described in this *Operator's Manual*. Always provide the manual with the equipment for proper and safe operation.

CHECK LIST

- Visually inspect the equipment to ensure that all instructions and decals are in place and legible.
- Inspect the light tower locking bar latch assembly which locks the light tower in the vertical position for proper operation.
- Check the hitch assembly and safety chains.
- Check the outriggers and jacks to make sure they operate properly.
- Inspect the light assemblies for damage and test for proper operation.
- Inspect the electrical wiring for signs of damage. **Danger! *Electrocution Hazard.***

Do not operate the light tower if the insulation on the electrical cord or other electrical wiring is cut or worn, or if bare wires are exposed. Repair or replace damaged wiring before starting the engine.

- Check ground rod cable and the ground lug. Make sure they are clean, undamaged and functional.
- Inspect tires to insure good condition and proper inflation.
- Check engine oil, fuel, engine coolant levels and hydraulic fluid levels, if equipped.
- Check to make sure the *Light Tower Operator's Manual and Generator Operator's Manual* are with the equipment.
- Check to make sure the quick reference operation card is with the equipment and properly tethered.
- Inspect the machine physically for damage and repair if necessary.

NOTICE: See appropriate section of the *Engine Operator's Manual and Generator Operator's Manual* for additional pre-operation checks.

TRAILERING, TRANSPORTING AND LIFTING

5/24/2011

After completing the pre-operation check list, operate the tower through a complete operation cycle, following the operating instructions in the NIGHT LITE PRO Operator's Manual.

Warning! *Unsafe operation Hazard. Never permit anyone to install or operate the equipment without proper training.*

ALWAYS READ AND UNDERSTAND THE INSTRUCTIONS FIRST.

Before trailering, transporting or lifting, read *Safety* on page 8.

The complete engine and generator set is housed in a lockable enclosure with the frame fabricated from heavy gauge steel mounted on a two-wheel, leaf spring axle.

BEFORE TRAILERING OR TRANSPORTING

Perform the following before trailering / transporting:

- Lower the light tower and shut down the tower lights and the engine; See *Shutdown - prepare for trailering* on page 16.
- Visually inspect the trailer and equipment for damage. Repair or replace any components as needed before trailering.
- Check the trailer lights for proper operation
- Inspect the tires to insure good condition and proper inflation.
- Inspect trailer springs and undercarriage for damage or loose parts.
- Check the hitch assembly and safety chains.
- Ensure the outriggers and jacks are properly stowed.
- Ensure the ground rod and cable are disconnected and properly stowed.
- Clean any spills from inside the trailer bilge area around the outside of the trailer; they may have occurred during operation.
- Ensure all compartment doors are closed and securely locked.

Shutdown - Prepare for Trailering

1. With the tower lights off, lower the light tower to the full DOWN position; See *Raising and Lowering the light tower* on page 39.

2. Turn the engine off. Refer to your *Engine Operator's Manual* for stopping procedure.

Notice: See appropriate section of the *Engine Operators Manual and Generator Operator's Manual* for additional post - operation and shutdown procedures.

3. Adjust the light bar and light fixtures for trailering; see *Tower lights - Stowage for trailering* on Page 17.

Notice: Visually inspect the light mounting brackets and hardware for loose fasteners or damaged brackets. Repair any problems before trailering.

4. Secure the light cords into the hook on the rear mast support

5. Disconnect the ground rod cable from the ground lug. Remove the ground rod from the earth and clean and secure the ground rod and cable in the trailer.

6. Close, secure and lock all compartment doors.

7. Raise each rear stabilizer jack and rotate into trailering position (horizontal with outrigger bar).

8. Retract each outrigger bar and secure in the stowed position with latch pin.

Notice: Be sure each outrigger jack is securely latched in transporting position by installing the outrigger lock pins before transporting.

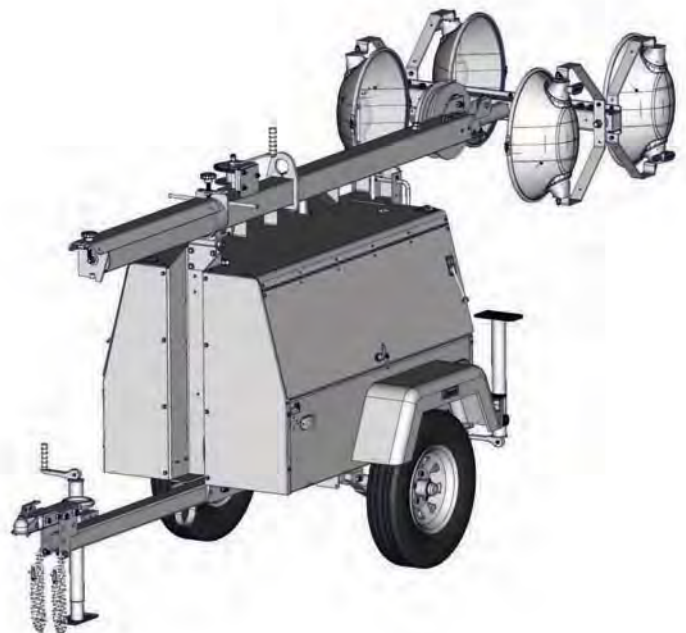

Tower Lights - Stowage for Trailering

The light bar and fixtures must be stowed before trailering or transporting.

WARNING! *Burn Hazard.* The light fixtures become extremely hot during use.

Always use caution and heat - resistant gloves when handling the Lights or allow to the lights to sufficiently cool down before handling.

1. Ensure lights are off and tower is lowered to the full DOWN position; see *Raising and lowering the light Tower* on page 39.
2. Release the light bar park pin by pulling the ring and turning it 90 degrees so that the pin remains in the retracted position.
3. Rotate the light bar into the trailering / transport park position (in line with trailer) and engage the park pin by twisting the park pin ring until the plunger is released and the pin engages and locks into the hole in the light bar.
4. Reposition the light fixtures for trailering / transport by pulling them down into the lowest position and face the fixtures toward the center of the trailer. (**see below**)

NOTE: If lights are to be removed for trailering / transporting, see *Tower Lights - Removal for trailering / transporting* (Optional) on page 18.

Tower Lights - Removal for Trailering (Optional)

Your light tower may be equipped with lights that can be removed for trailering / transport or for theft prevention.

WARNING! Burn Hazard. The light fixtures become extremely hot during use.

Always use caution and heat - resistant gloves when handling the Lights or allow to the lights to sufficiently cool down before handling.

1. Ensure lights are off and tower is lowered to the full DOWN position; see *Raising and lowering the light Tower* on page 39.
2. Disconnect the electrical cord from each light fixture.
3. While supporting the light fixture, remove the nut and washer assembly fastening the main fixture Bracket and remove each light fixture and bracket (**Figure 23**).
4. Store each light fixture to avoid any damage during transport.

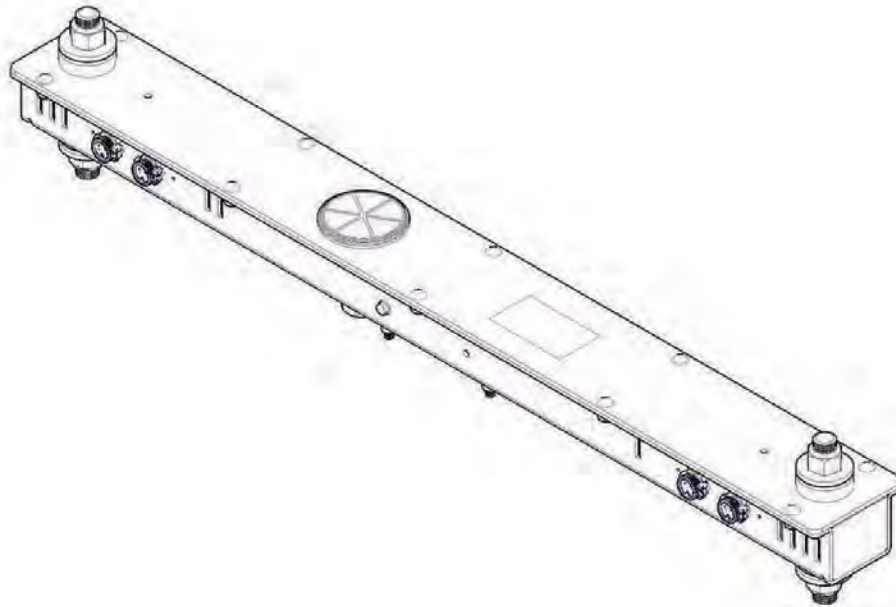

FIGURE 23

TRAILERING / TOWING

Before trailering / towing the light tower trailer, read *Before Trailering / Transporting* on page 15 and read *Safety* on page 8.

NOTICE: Maximum highway speed is 50 mph (80 km/h) and maximum off highway speed is 10 mph (16 km/h). Do not exceed these limits or damage to light tower may occur.

Trailer Component Identification

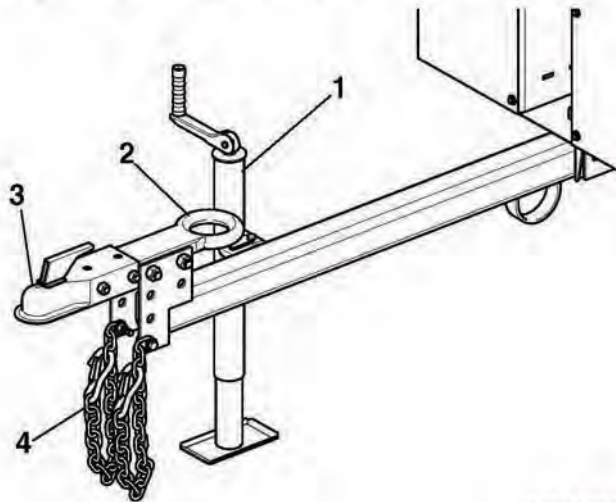

ALB_O_0009

Figure 24

- 1 –Tongue Jack - Used to raise, lower and level trailer tongue**
- 2 –Pintle Ring Hitch Coupler (3 in.)**
- 3 –Ball Hitch Coupler (2 in.)**
- 4 –Safety Chains - Safety connection to tow vehicle in case coupler disconnects**

Towing Vehicle and Hitch Considerations

The towing vehicle must be able to safely pull the full trailer load. Never pull a trailer load that exceeds the vehicle's towing capacity; you risk losing control of the trailer and/or vehicle. Before trailering, always check your vehicle owner's manual for maximum towing/trailering load specifications and maximum gross vehicle weight specifications that include the fully loaded trailer.

The vehicle must have a towing hitch that is capable of safely handling the trailering load and tongue weight of the trailer.

WARNING! Control Hazard. A vehicle hitch that is underrated or improperly installed can lead to loss of control of the trailer and/or vehicle. Never use a hitch size or rating that does not match the trailer coupler specifications.

Connecting the Trailer Hitch Coupler and Lights

The trailer is equipped with a combination trailer coupler for a 2-inch ball hitch and a 3-inch lunette ring for a pintle hitch.

The trailer coupler must be reversed to use either the ball or lunette hitch coupler. To reverse the coupler, remove the two bolts and reposition the coupler as needed.

WARNING! Control Hazard. Ensure the coupler bolts are tightened before trailering.

Typical Lunette Ring Pintle Type Hitch and Coupler

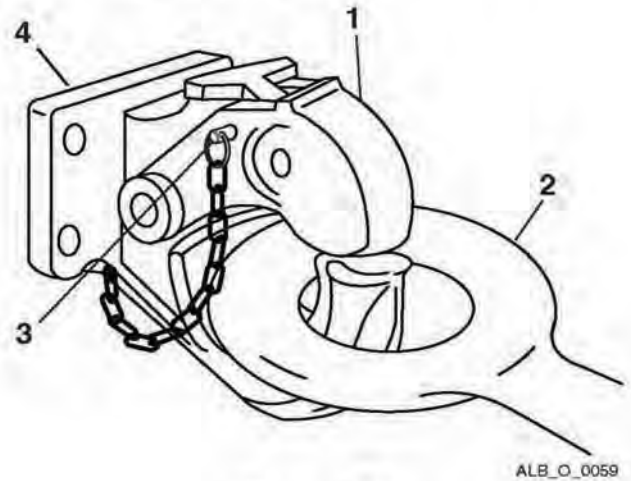

Figure 25

- 1 – Latch and Release Lever
- 2 – Trailer Coupler Lunette Ring
- 3 – Latch Lever Safety Pin
- 4 – Vehicle Hitch

Typical Ball Type Hitch and Coupler

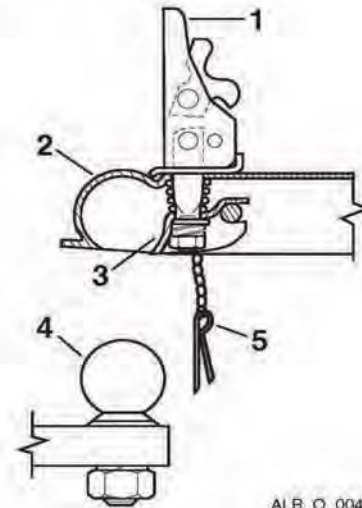

Figure 26

- 1 – Latch and Release Lever
- 2 – Trailer Coupler Socket
- 3 – Coupler Clamp
- 4 – Vehicle Hitch and Ball
- 5 – Latch Lever Safety Pin

The trailer's safety chains prevent the trailer from completely detaching from the towing vehicle when underway.

NOTICE: Safety chains must be rated at the same or greater weight capacity as the trailer's GVWR.

Before trailering, read *Before Trailering / Transporting* on page 15.

1. Connect the tow vehicle hitch to the trailer coupler. Make sure the coupler is securely attached to the tow vehicle's hitch.
2. Connect the safety chains (**Figure 27, 2**) to the vehicle's hitch frame and crisscross the chains under the trailer tongue to prevent the tongue from dropping to the road if the trailer separates from the hitch ball. Rig the chains as tight as possible with enough slack to permit free turning.

WARNING! Control Hazard. Attach the safety chains properly and securely between the towing vehicle and trailer before trailering. Never allow the chains to drag on the ground when trailering.

3. Connect the 4-pin light connector (**Figure 27, 1**) from the vehicle harness to the trailer harness.
4. Ensure there is adequate slack in the harness to prevent binding or disconnection when turning.

NOTICE: Do not allow excessive harness slack or the harness can be damaged from scraping the ground.

5. Before trailering, check all lights for proper operation.

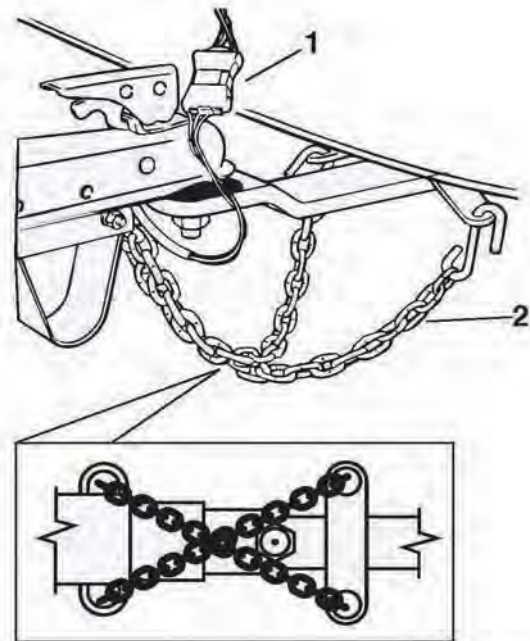

ALB_O_0045

Figure 27

- 1 –4-pin Trailer Light Harness Connector
- 2 –Trailer Safety Chains

LIFTING THE LIGHT TOWER

The approximate fully loaded weight of the light tower and trailer is 1807 lbs. (820 kg) with four fixtures

The **NIGHT LITE PRO** light tower is equipped with top forklift pockets and a lifting eye for lifting or hoisting.

The safety messages that follow have **Warning level hazards**.

- **Rollover hazard. Before lifting, lower the light tower and shut down the tower lights and the engine; see Shutdown - Prepare for Trailering on page 20.**
- **Crush Hazard. Always make sure the lifting device you are using is in good condition and is rated for the maximum capacity of the task to safely lift the light tower trailer.**
- **Crush Hazard. Always acquire assistance when using a forklift, crane or hoist and when unloading.**
- **Crush hazard. Only use the lifting eye on the lifting bar to lift or hoist the unit with a hoist or crane.**
- **Crush hazard. Only use shackles or a locking - type hook when lifting.**
- **Crush hazard. Do not stand or walk under the unit when lifted and keep others away.**

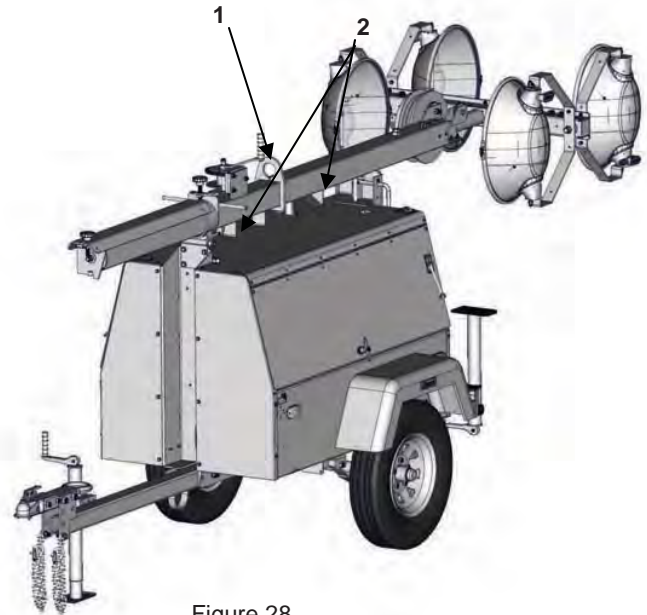

Figure 28

1. Lifting Eye
2. Forklift Lift Pockets

TRANSPORTING ON A TRAILER

When transporting on a truck or trailer, always secure the unit using properly rated tie - down chains or straps connecting the light tower trailer frame to the towing trailer. The operator of the towing vehicle is responsible for securing the load properly.

EQUIPMENT IDENTIFICATION

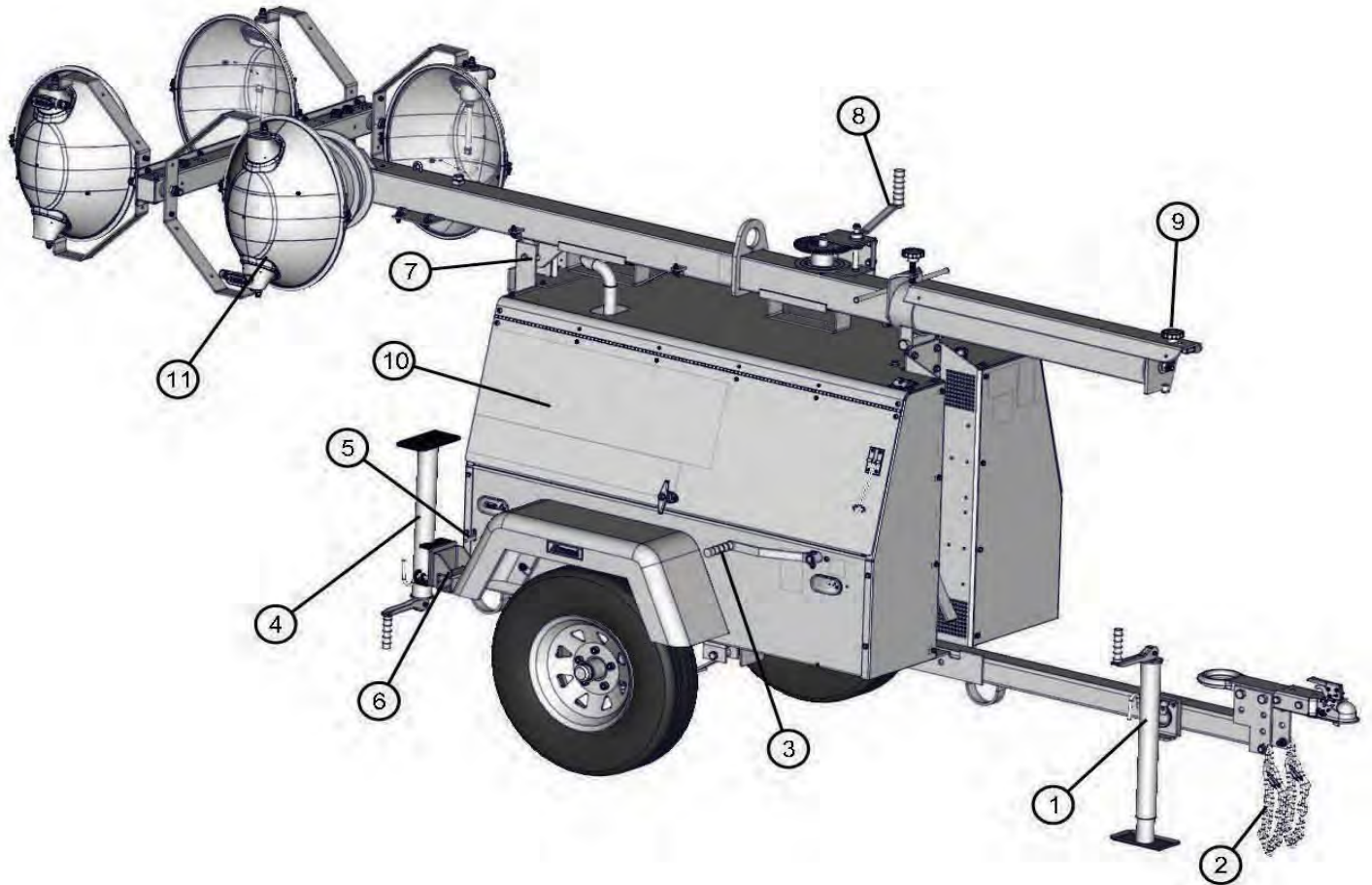

NO	QTY	DESCRIPTION
1	1	TONGUE JACK
2	1	SAFETY CHAIN
3	1	TOWER WINCH HANDLE
4	1	REAR STABILIZER
5	1	RIGHT RETENTION PIN
6	1	OUTRIGGER
7	1	REAR TOWER LOCKING PIN
8	1	WINCH DBL 1200 7
9	1	LOCKING KNOB
10	1	RIGHT SIDE DOOR FUEL TANK ACCESS
11	1	SHO 1000 LAMPHOLDER

MODEL AND SERIAL NUMBERS

Model and serial number information is required for product support and repair parts. The following descriptions show model and serial number locations of the primary components.

Trailer

All **NIGHT LITE PRO** trailers have a serial number plate (**Figure 3,1**) attached to the rear panel.

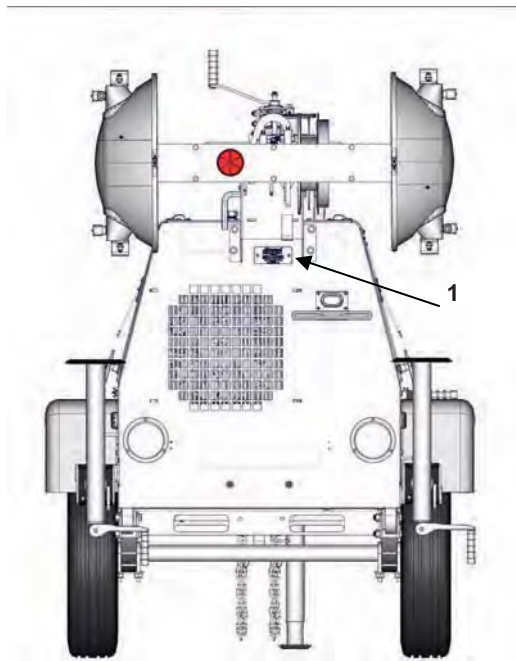

FIGURE 3

Generator

The generator has a serial number plate (**Figure 4, 1**) attached to the side of the housing. The serial number is also stamped into the housing.



Marathon Generator

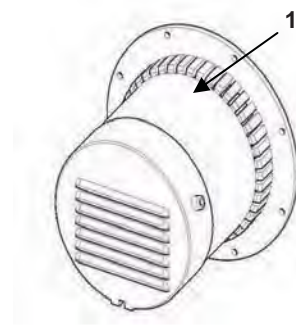

Mecc Alte Generator

FIGURE 4

Engine

The KOHLER Engine has the serial number plate (**Figure 5**) attached to left side of the engine block by the oil filter

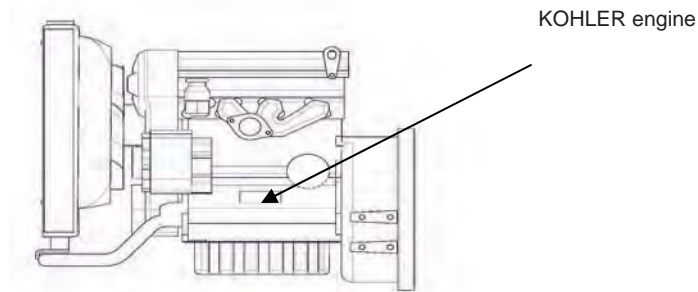

The CATERPILLAR® engine has a serial number plate (**Figure 6**) attached on the upper right side of the engine block above the fuel injection pump.

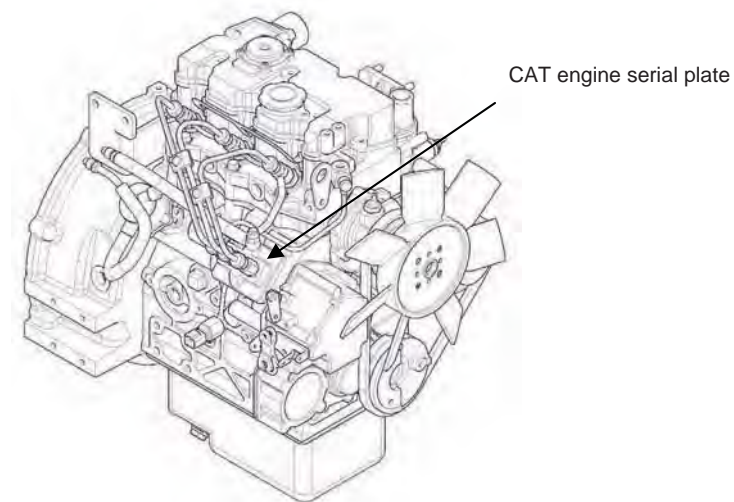

Engine

The KUBOTA engine has the serial number stamped (**Figure 7**) on the engine block just below the exhaust manifold.

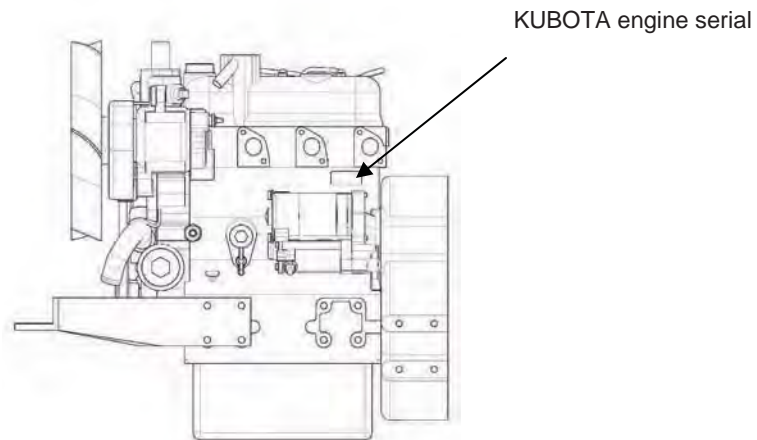

SPECIFICATIONS (STANDARD AND OPTIOANAL FEATURES)

NOTICE: Refer to the Engine or Generator operator's Manual for specific engine or generator specifications.

Trailer

Hitch Coupler	Adjustable height, reversable combination, 2 in. (50 mm) ball, 3 in. (75 mm) pintle hitch
Max. Road Speed (paved road)	50 mph (80 km/h)
Max. Off - road Speed	10 mph (16.1 km/h)
Number of Axles	1
Axle Rating	2000 lbs (907.1 kg)
Tire Size & Rating	13 in. B
Max Tire Pressure	See Tire Manufacture Specification
Door Locks	Standard
Trailer Lights: Stop, Turn and Running	D.O.T. Approved
Trailer Light Connector	4 - Pin Plug
Lifting Eye	Standard
Tie - Down Rings	Standard
Rear Forklift Pockets	Standard
Side Forklift Pockets	Standard
Top Forklift Pockets	Standard
Number of Stablizers	3
Number of Outrigger Stabilizers	2
Tongue Jack	Standard
Ground Rod	Standard

Light Tower

Sections	3
MANUAL TOWER	Standard
ELECTRIC WINCH	Optional
Max Wind Load 53 mph (85.3 km/h)	Standard
Light Bar Rotation	360°
Tower Cord Reel	Optional

Overall Dimensions

Height Light Tower Lowered	7 Ft 1 in. (2.2 m)
Height Light Tower Raised	25 ft (7.9 m)
Width (outriggers retracted)	4 ft 3 in. (1.3 m)
Width (outriggers extended)	7 ft 9 in. (2.24 m)
Length w/o Fixtures	9 ft 5 in. (2.9 m)
Length with Fixtures	9 ft 5 in. (2.9 m)
Dry Weight	1540 lbs (699 kg)
Operating Weight	1807 lbs (820 kg)

Generator

7.5 kW	Standard
8 kW	Optional
120VAC Convenience Outlet	Standard
125/250VAC Twist - Lock	Optional
Main Disconnect Breaker	Optional

GENERAL SERVICE INFORMATION

5/24/2011

Tower Lights

SHO - HD 1250W Metal Halide (lumen rating: 150,000)	Standard
SHO - HD 1000W Metal Halide (lumen rating: 110,000)	Optional
SHO - HD 1000W and 1250W Metal Halide	Warm - up time: 2-4 minutes
SHO - HD 1000W and 1205W Metal Halide	Re - start time: 10 to 15 minutes
Four Fixtures	Standard (sealed for all weather use)
Light Fixture Weight	15 lbs (6.75 kg)
Individual Light Switches	
1000W Light Switch (2 per 4 lights)	Standard
1000W HPS Light Switch (2 per 2 lights)	Standard
1250W Light Switch (2 per light)	Standard
Individual Ballast (1 ballast per light)	Standard

GENERAL SERVICE INFORMATION

5/24/2011

Engine

Model	Kubota D1105BG (Optional)	Lombardini LDW 1003 (Standard)	Cat C1.1 (Optional)
Type	Water-cooled 4-cycle diesel		
Bore	2.99 in. (76 mm)	2.96 in. (75 mm)	3.03 in. (77 mm)
Stroke	2.90 in. (73.6 mm)	3.05 in. (77.6 mm)	3.19 in. (81 mm)
Displacement	61.1 cu. in. (1002 cc)	62.6 cu. in. (1028 cc)	69 cu. in. (1100 cc)
Power@1800 rpm	13.6 hp (11.4 kW)	13.4 hp (11.2 kW)	14.3 hp (11.9 kW)
Power Output Derating	3% per 1000 ft above 360 ft 1% per 10° above 77° F		
Note: Horsepower ratings are established in accordance with Society of Automotive Engineers Small Engine Test Code - J1349 GROSS.			
Fuel System	Indirect injected diesel		Cassette type fuel injected diesel
Starting System	12VDC Negative Ground		
Electrical System	12VDC Negative Ground		
Battery Type	Group 24		
Battery Rating	550 CCA		
Number of Batteries	1		
Compression Ratio	22:1	22.8:1	22:1
Weight	205 lb (93 kg)	191 lb (87 kg)	191 lb (87 kg)
Oil Capacity	5.4 qt (5.1 L)	2.5 qt (2.4 L)	3.9 qt (3.7 L)
Lubrication	Forced lubrication by pump		
Oil Filtration	Cartridge type		
Cooling System	Pressurized radiator forced circulation with water pump		
Low oil pressure engine shutdown	Standard (All Engines)		
High engine temperature shutdown			
Glow plug cold start assist			
Fuel	Use a clean No. 2 Diesel fuel oil (SAE J313 JUN87) according to ASTM D975. Do not use alternative fuel, because its quality is unknown or it may be inferior in quality, and kerosene, which is very low in cetane rating, adversely affects the engine. Refer to the <i>Engine Operator's Manual</i> for more detailed fuel requirements.		
Engine Oil	Use a high-quality engine oil of API (American Petroleum Institute) service class CC/CD/CE. Refer to the <i>Engine Operator's Manual</i> for more detailed engine oil requirements.		
Fuel Tank	30 gal (114 L)		
Cooling System	See <i>Engine Operator's Manual</i>		
Engine Oil	See <i>Engine Operator's Manual</i>		

OPTIONAL ACCESSORY EQUIPMENT

- Saf - t - Visor
- LSC100 Light Sequence Commander
- Heavy Duty Battery (675 CCA)
- Battery Heating Pad
- Engine Block Heater
- Sound Attenuation package
- 7 - Blade RV Taillight Connector
- Bulldog Hitch (ball/pintle)
- VIN Package (for licensing)
- Quick - Disconnect Lamp Fixtures
- Chalwyn - Emergency Air Shutoff (Caterpillar or Kubota engines only)

Before performing any operation procedures, read *Safety* on page 8.

PRE-OPERATION SETUP

Work Site Safety Considerations

Height

DANGER! Electrocuting Hazard. Always check for overhead wires and obstructions before raising or lowering the light tower. Allow 35 feet (10.6 m) of clearance.

Ground Surface

WARNING! Rollover Hazard. Do not set up on an incline of more than 5° front-to-back and side-to-side.

WARNING! Rollover Hazard. Do not position or set up on unlevel or unstable ground. Only set up on smooth, flat and solid ground surfaces.

Wind

WARNING! Rollover Hazard. Do not operate with the light tower extended in winds exceeding 53 mph (85.3 km/h).

When the light tower is in the operating position it is located in the middle of a three-point outrigger system for optimum balance and stability. This system was engineered to allow the light tower to remain operational in sustained winds of 53 mph (85.3 km/h) with the light tower extended to full height and the outriggers in position.

Pre-Operation Check List

Always perform the following checks before traveling to the work site and before operation. Repair or replace any components as required before operation.

NOTICE: See appropriate section of the *Engine Operator's Manual* and *Generator Operator's Manual* for additional pre-operation checks.

After completing the pre-operation check list, operate the light tower through a complete operation cycle.

- Visually inspect the equipment to ensure that all instructions and decals are in place and legible.
- Inspect the light tower locking bar latch assembly, which locks the light tower in the vertical position, for proper operation.
- Check the hitch assembly and safety chains.
- Check the outriggers and jacks to make sure they operate properly.
- Inspect the light assemblies for damage and test for proper operation.
- Inspect the electrical wiring for signs of damage.

WARNING! Electrocuting Hazard. Do not operate the light tower if the insulation on the electrical cord or other electrical wiring is cut or worn, or if bare wires are exposed.

- Check the ground rod cable and the ground lug. Make sure they are clean, undamaged and functional.
- Inspect the tires to ensure good condition and proper inflation.
- Check engine oil, fuel, engine coolant levels and hydraulic fluid levels, if equipped.
- Check to make sure the *Light Tower Operator's Manual*, *Engine Operator's Manual* and *Generator Operator's Manual* are with the equipment.
- Check to make sure the quick reference operation card is with the equipment and properly tethered.

- Physically inspect the machine for damage and repair if necessary.

Leveling and Stabilizing the Trailer

WARNING! ROLLOVER HAZARD. Do not set up on unlevel ground. Only set up on smooth, flat and solid ground surfaces. Always level the light tower trailer before raising the light tower.

The **NIGHT LITE PRO** must be leveled to 5° or less, front-to-back and side-to-side.

1. Position **NIGHT LITE PRO** on an adequate site; see *Work Site Safety Considerations* on page 32.
2. Block each wheel on each side with a suitable wheel chock (**Figure 8,1**).

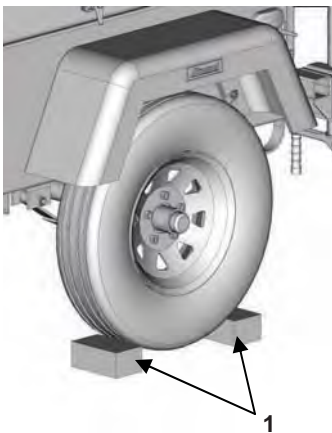

Figure 8

3. Extend the front outrigger stabilizers out and lock in place (**Figure 9**).
4. Rotate each rear stabilizer jack perpendicular with the ground and lock in place.
5. Adjust each rear stabilizer jack and the tongue jack to achieve proper leveling. Turning the handles clockwise will raise the jacks, and counterclockwise will lower the jacks.

WARNING! Rollover Hazard. All stabilizer jacks must be supported by a flat, level solid ground surface.

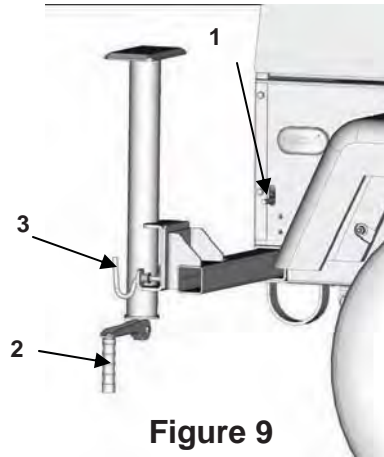

Figure 9

1. **Outrigger Lock Pin** - Locks outrigger in position.
2. **Jack Handle (front)** - Used to raise or lower outrigger jack.
3. **Jack Pin** - Locks jack in position to prevent jack from rotating.

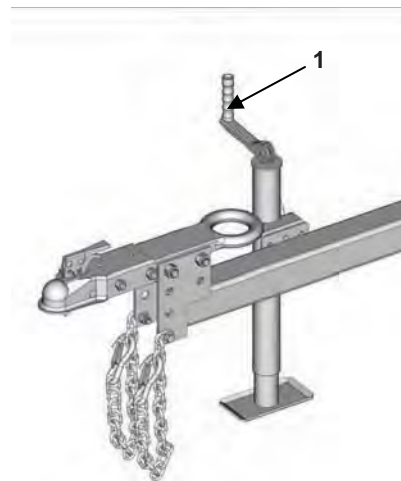

Figure 10

1. **Tongue Jack Handle** - Used to raise or lower tongue jack.

Installing the Ground Rod

The ground rod is a safety device that may reduce the chance of personal injury from stray electrical current. Therefore, Allmand recommends using the ground rod. However, it is the user's responsibility to determine the requirements and/or applicability of local, state or national electrical code which governs the use of the ground rod.

Drive the ground rod fully into the ground using a hammer. Attach the supplied cable to the rod and then attach the cable to the ground lug on the unit. Make sure the cable connections are tightened.

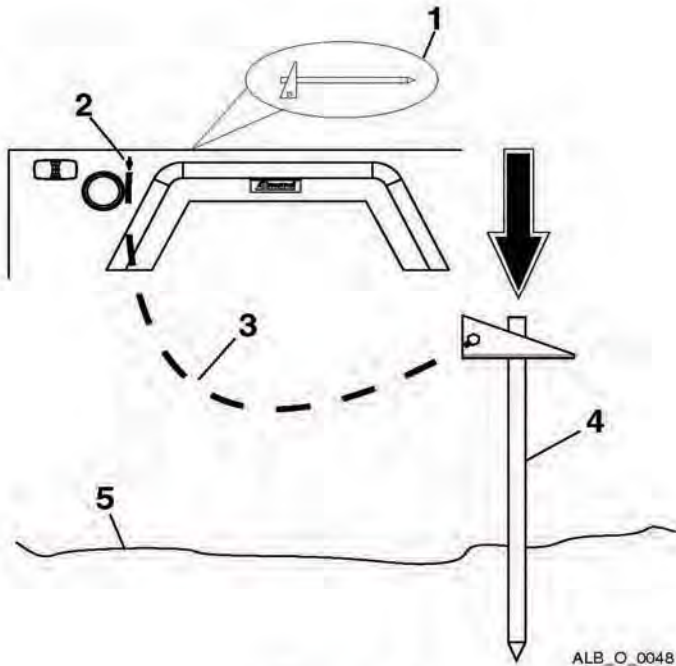

Figure 11

- 1 –Ground Rod Storage Location (inside left panel)
- 2 –Ground Rod Connection Stud and Wingnut
- 3 –Ground Rod Wire
- 4 –Ground Rod
- 5 –Earth / Ground

ENGINE OPERATION

Before starting the engine or operating the light tower, review *Safety on page 3*.

The Allmand **NIGHT-LITE PRO V-Series** hydraulic light tower is powered by a diesel engine and generator unit.

Pre-Start Checks

1. Check the engine oil and add oil if required. Fill the engine with the proper grade of lubricating oil; refer to *Engine Operator's Manual* for oil specifications.
2. Check and add diesel fuel as required.
3. Ensure that the air cleaner is firmly attached and air cleaner seals and hose clamps are properly sealed. Air cleaner element should be checked and replaced if necessary.

Engine Control Panels

The engine control panel consist of the engine start/stop key and hour meter.

CAT Control Panel - Manual Winch

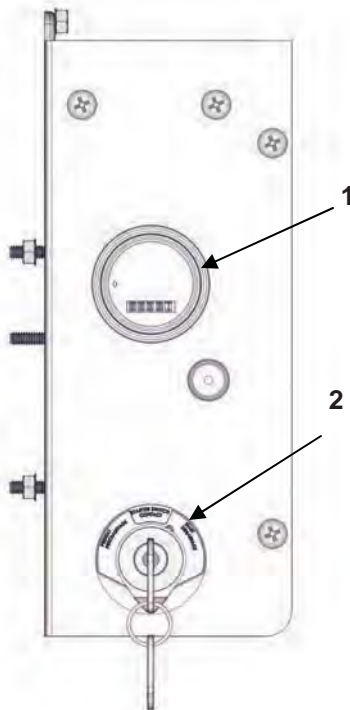

Figure 12

1. Hour Meter - Shows the Total elapsed hours of engine operation.
2. Key Switch (Key start models only).

CAT Control Panel - Electric Winch

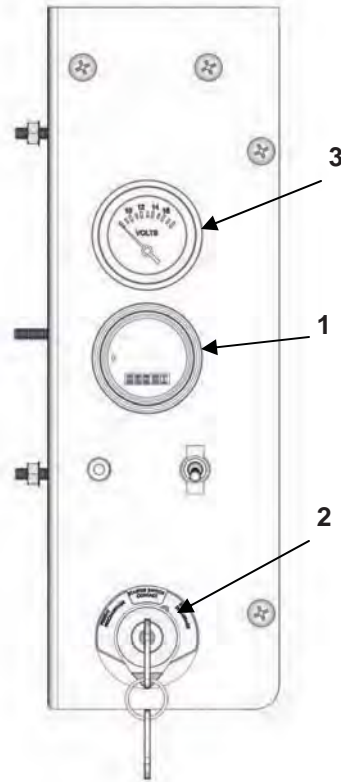

Figure 12A

1. Hour Meter - Shows the Total elapsed hours of engine operation.
2. Key Switch (Key start models only).
3. Voltmeter

KOHLER

Control Panel - Manual or electric Winch

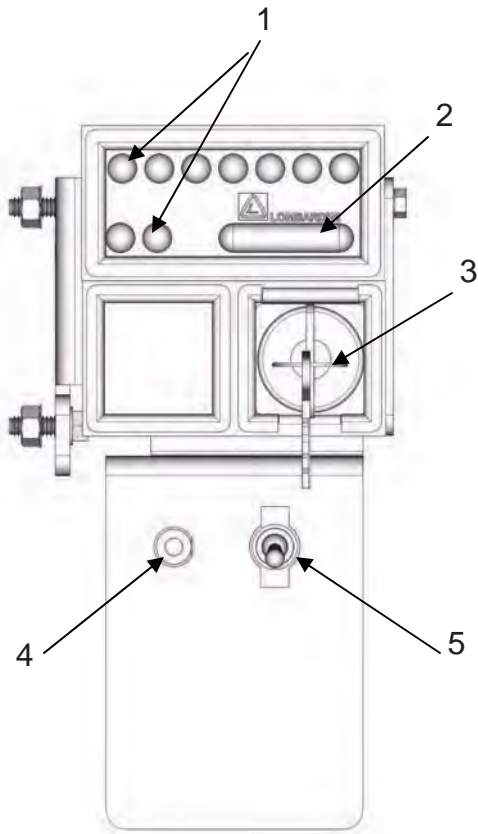

Figure 13

KOHLER Control Panel

- 1. Engine Warning Indicator Lights.
- 2. Hour Meter - Shows the total elapsed hours of engine operation.
- 3. Key Switch.
- 4. Push Breaker. (Electric Winch only)
- 5. Toggle switch. (Electric Winch only)

KUBOTA Control Panel

Manual Winch

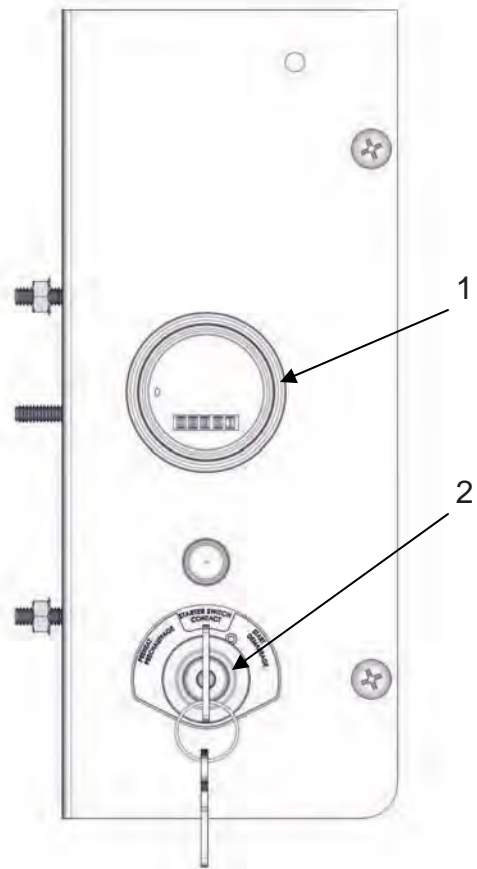

Figure 14

- 1. Hour Meter - Shows the total elapsed hours of engine operation.
- 2. Key Switch.

KUBOTA Deep Sea Control Panel (OPTION)

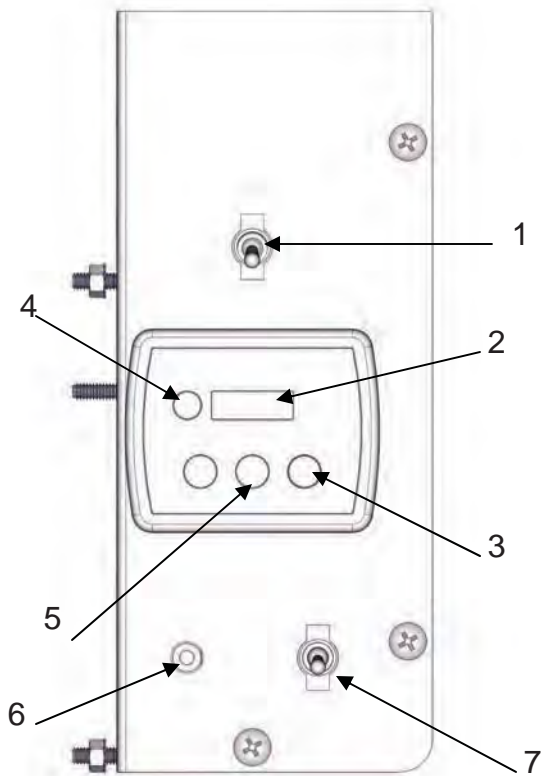

Figure 15

1. Main Panel ON/OFF Switch.
2. Hour Meter - Shows the total elapsed hours of engine operation.
3. Start Button.
4. Engine Warning Indicator Lights.
5. Glow Plug Indicator.
6. Push button breaker.
7. Electric winch switch.

Starting the Engine

The Starting procedure is different Depending on the engine model used. Refer to your *Engine Operator's Manual* for the starting procedure.

Cold - Weather Starting

The cold - weather Starting procedure is different Depending on the engine model used. Refer to your *Engine Operator's Manual* for the cold - starting procedure.

If Engine has Run Out of Fuel

1. Refill the fuel tank.
2. Refer to your *Engine Operator's Manual* for the starting procedure.

Notice: Do not operate starter for more than 10 seconds without allowing 30 seconds to pass between starting attempts. Possible starter damage could result from excessive heat caused by cranking too long.

Notice: If the engine develops sufficient speed to disengage the starter but does not keep running (a false start), the engine rotation must be allowed to come to a complete stop before attempting to restart the engine.

If starter is engaged while the flywheels rotating, the starter pinion and flywheel ring gear may clash, resulting in damage to the starter or flywheel ring gear.

Stopping the Engine

The engine stopping procedure may differ depending on the engine model. Refer to your *Engine Operator's Manual* for engine stopping procedures.

Automatic Engine shutdown System

The engine is equipped with an automatic engine shutdown system to prevent excessive engine damage in the event of a low oil or overheat condition. For additional information, refer to your *Engine Operator's Manual*.

Low Oil Pressure Shutoff

Should a low oil pressure condition occur, the oil pressure sending unit breaks the circuit between the battery and the fuel solenoid, allowing the spring load to immediately move the fuel control to the shutoff position.

High Coolant Temperature Shutoff

Should a high coolant temperature condition occur, the temperature sending unit breaks the circuit between the battery and the fuel solenoid, allowing the spring load to immediately move the fuel control to the shutoff position.

TOWER LIGHT OPERATION

Before operating the tower light, review *Safety* on page 8.

The light tower is raised and lowered by a hydraulic pump actuating a 7-section telescoping mast.

WARNING! Rollover Hazard. Before raising, lowering or operating the tower lights, the trailer must be set up, properly leveled and stabilized, and ground rod installed. see Pre-Operation Setup section on page 32.

WARNING! Crush Hazard. Allow adequate clearance around and above trailer when raising or lowering the light tower. Ensure that there are no obstructions or persons near the light tower when raising or lowering the light tower.

Light Bar and Light Fixture Adjustment

Lights - Work Site Adjustment

The light fixtures must be adjusted to the desired work angle before raising the tower.

With the light tower fully lowered and the lights off, the light fixtures can be manually rotated into the desired working position.

To adjust each light fixture, manually swivel each light fixture at its base into the desired working position. **(Figure 17).**

1 - Grasp light fixture here to adjust. _____



Figure 17

Lights - Trailing Storage

The light bar and light fixtures must be stowed properly for trailering or transporting. See *Tower Lights - Stowage for Trailing* on page 30.

RAISING MANUAL WINCH MAST, RAISING AND LOWERING LIGHTS

Manual Winch Light Tower

NOTE; The manual winch tower can be raised and extended by operating two hand crank winches. One winch, mounted with the handle extending through the side of the trailer frame, raises and lowers the mast from the horizontal towing position to the vertical position and back. The second winch mounted on the tower extends and retracts the telescopic sections.

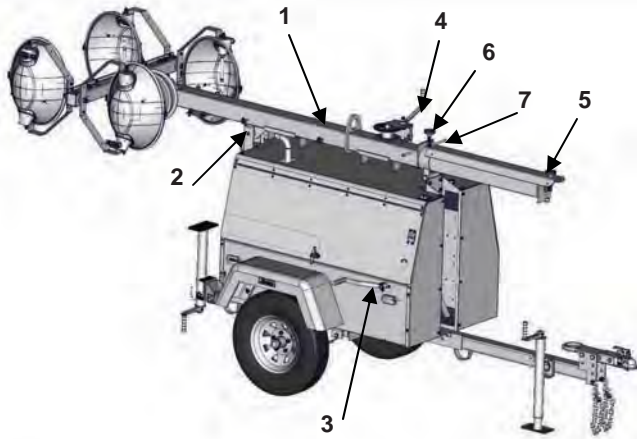

Figure 18a

1. Manual Winch Tower.
2. Rear Support Release Pin - locks tower in position for towing, trailering or lifting.
3. Lower Hand Crank Winch - raising and lowering mast.
4. Upper Hand Crank Winch - raising and lowering lights.
5. Mast Locking Pin - locks mast in vertical position.
6. Mast Rotation Locking Knob - locks mast in desired position.
7. Handles - used to turn tower to desired position.

Raising

1. Before raising the light tower, adjust the tower lights to the desired work position; see *Light Bar and Light Fixture Adjustment* on page 38.
2. Turn the lights off; see *Light Control Panel* on page 40.
3. Release the pin that secures the mast to the rear mast support.
4. Operate the hand crank on the right side of the trailer to raise the mast from horizontal to vertical.
5. Turn lower black knob counterclockwise and engage latch in strike plate. Turn lower knob clockwise to retighten.
6. Operate the hand crank winch on the tower clockwise to raise the lights vertically.
7. To rotate lights, turn upper black knob counterclockwise and turn the tower with handles provided.

Lowering

1. Turn lights off; see *Light Control Panel* on page 40.
2. Loosen upper black knob and rotate tower until handles they are parallel with the front of the trailer and retighten knob.
3. Operate upper hand crank winch counterclockwise to lower the lights to the lowest vertical position.
4. Operate lower hand crank winch on side of trailer clockwise to take up any slack in the cable.
5. Turn lower black knob counterclockwise and lift to release the latch from the strike plate. Retighten the knob with the latch disengaged from the strike plate.
6. Operate the lower hand crank on the side of the trailer counterclockwise to lower the mast into the horizontal towing position.
7. Secure light cords into hook on the rear tower support.
8. Secure rear support release pin, locking mast to rear tower support for towing.

Light Control Panel

The tower light control panel consist of the breaker switches.

The four light fixtures are controlled and protected by four breaker switches located on the light control panel.



Figure 20

1. Light Breaker Switches.

Lights On

Before turning the lights on, the engine must be running and should be allowed to reach normal operating temperature.

Turn one or more light breaker switches to the ON position.

Lights Off

Turn all light breaker switches to the OFF position.

SHUTDOWN PROCEDURE

Shutdown - Short period

When shutting down the light tower for a short period, perform the following procedures.

1. With the lights off, lower the light tower to the full DOWN position; see *Raising and Lowering the Light Tower* on page 39.
2. Turn the engine off. Refer to your *Engine Operator's Manual* for stopping procedure.

Shutdown - Long - Term or Prepare for Trailering

When shutting down the light tower for long periods of time or when preparing to trailer; see *Long - Term Storage* section on page 47 or *Shutdown - Prepare for Trailering* section on page 16.

AUXILIARY AC OUTLET OPERATION

Depending on model options, the 240VAC 1 - phase outlet is equipped with two 240VAC outlet and one 110VAC GFCI outlets for powering accessories from the generator. Power is supplied to the outlets only when the engine / generator is running and the main circuit breaker is in the ON position.

The 240VAC outlet is protected by a 30A circuit breaker.

The 110VAC GFCI outlet is protected by a 20A push button type circuit breaker.

If any of the outlet circuit breakers trip, switch off the lights, remove the load to the outlets and wait 10 minutes for the bulbs to cool before turning them back on.

1. Disconnect the load from the outlet.
2. Turn off the tower lights (if used).

3. Correct the excessive load problem and wait 10 minutes, to allow the generator to cool down before reconnecting the load.

Outlets with circuit breakers 50Hz

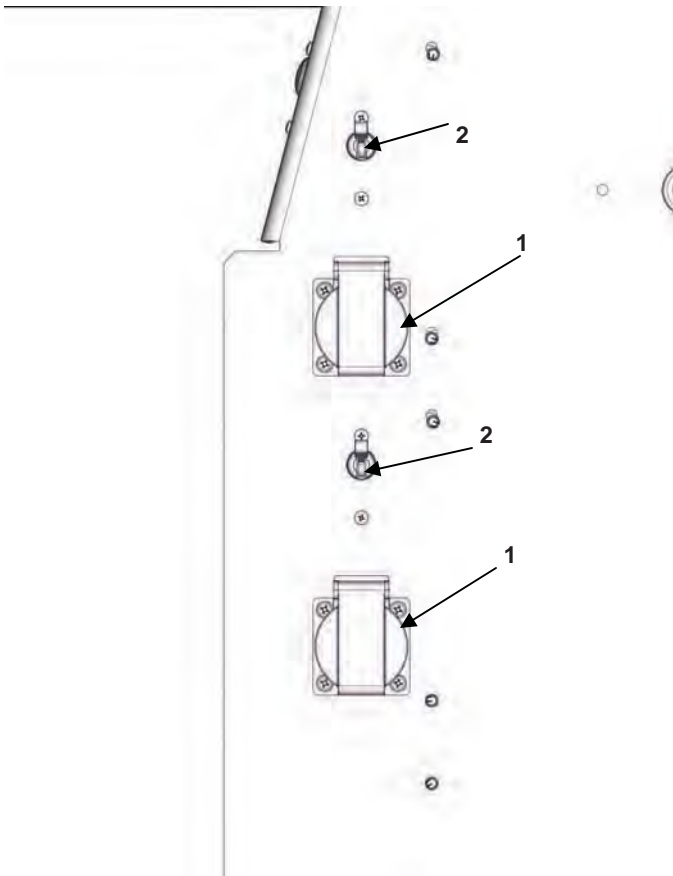

- 1. Shucko Receptacle
- 2. 15A DPST Circuit Breaker.

Outlets with circuit breakers 60Hz

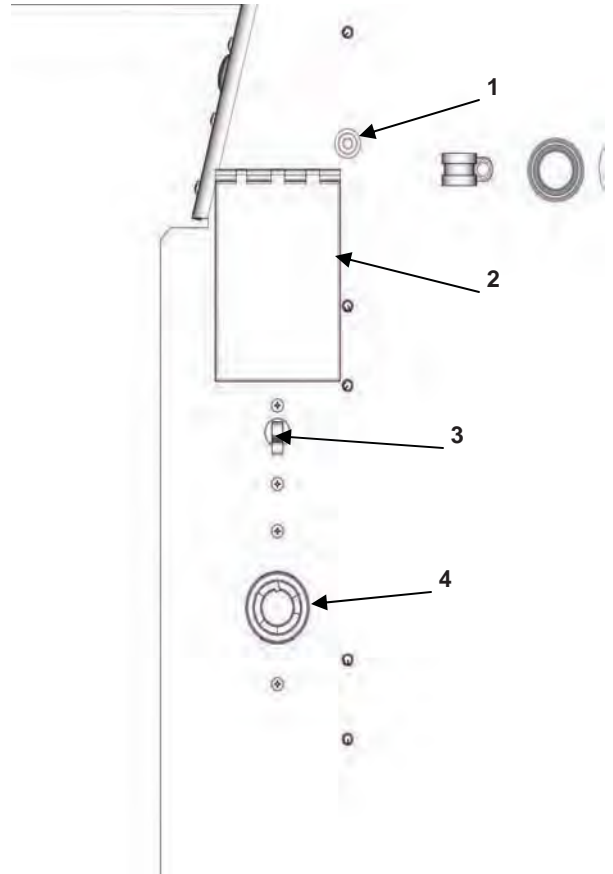

- 1. 20A push button Circuit Breaker.
- 2. 20A GFCI Receptacle.
- 3. 30A DPST Circuit Breaker.
- 4. 30A 250V Twistlock Receptacle.

Before performing any maintenance procedures, read Safety on page 8.

Scheduled maintenance prevents unexpected downtime, reduces the number of accidents due to poor equipment performance and helps extend the life of the light tower.

Proper maintenance and care of your light tower and trailer is a must for safe and reliable operation. Use the following maintenance and care guidelines in addition to those scheduled by your shop equipment maintenance schedule.

Where equipment is operated under severe conditions (very dusty, extreme heat or cold, etc.), affected items should be serviced more frequently.

ENGINE

Refer to the *Engine Operator's Manual* for all engine scheduled maintenance procedures.

Changing and Adding Engine Oil

Use a high - quality engine oil of API (American Petroleum Institute) service class CC/CD/CE. Refer to the *Engine Operator's Manual* for detailed engine oil specifications and service procedures.

All models are equipped with remote oil drains.

Engine Filters

Refer to the *Engine Operator's Manual* for air, oil and fuel filter service procedures.

ELECTRICAL SYSTEM

Refer to the Generator Operator's Manual for all generator schedule maintenance procedures.

Ballast Panel

The ballast panel is located on the left, front side of the light tower trailer. The ballast panel can be accessed by removing the front panel cover. The ballast panel contains the four tower light lamp ballast and capacitors. For additional wiring information, see *4 Light Ballast* on page 58 - 59.

The Safety messages that follow have WARNING level Electrocution Hazards.

- **Only qualified electricians should service or perform replacement procedures. Ballast and capacitors are capable of discharging high voltage. Always use appropriate personal safety clothing and gear when servicing electrical components.**
- **High voltage is present when engine is running. Never attempt to service electrical components while engine is running.**
- **Do not operate the light tower if the insulation on the electrical wiring is cut or worn, or if bare wires are exposed. Repair or replace damaged wiring before starting the engine.**

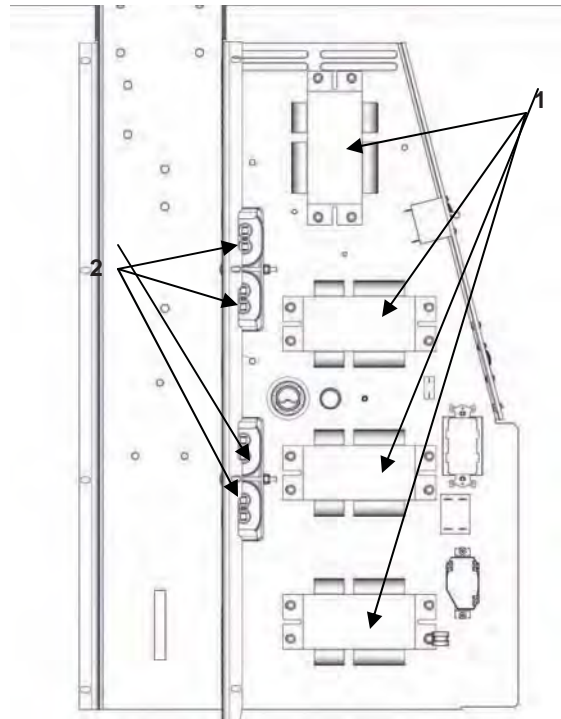

60Hz Ballast Panel

1. Lamp Ballast
2. Capacitors

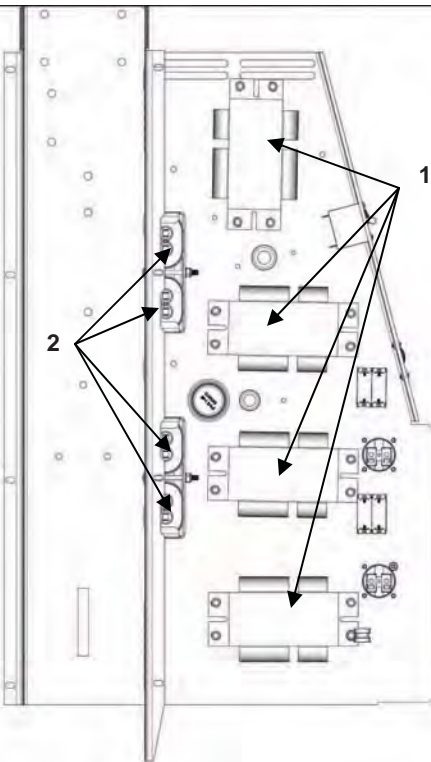

50Hz Ballast Panel

1. Lamp Ballast
2. Capacitors

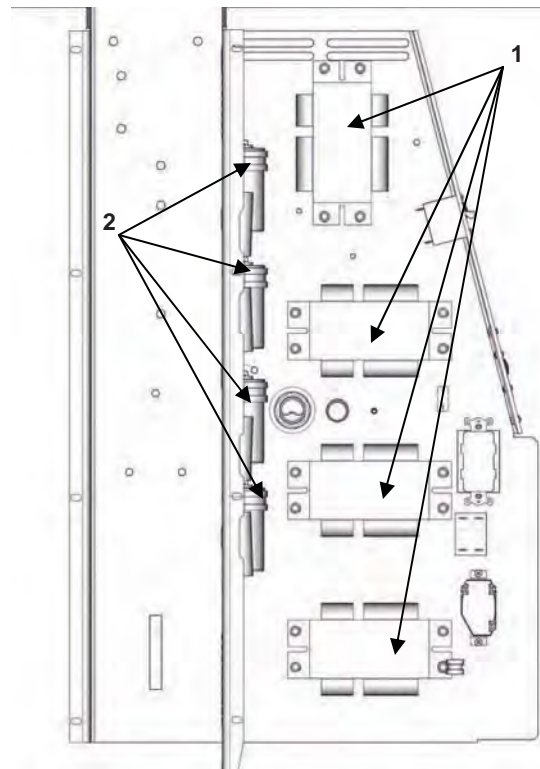

60Hz HPS Ballast Panel

1. Lamp Ballast
2. Capacitors

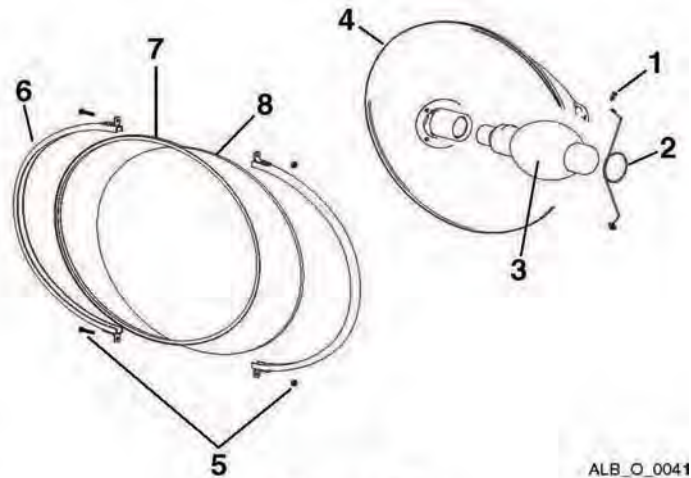

ALB_O_0041

Figure 33

- 1 –Support Clip Screws (2)
- 2 –Support Clip
- 3 –Lamp
- 4 –Reflector
- 5 –Lens Channel Screws and Nuts (2 each)
- 6 –Lens Channel
- 7 –Silicone Gasket
- 8 –Lens

LIGHT TOWER AND LAMPS

Changing Lamps

WARNING! Burn Hazard. The light bulbs and the fixtures become extremely hot during use. Allow the bulbs and fixtures to sufficiently cool down before changing bulbs or severe burns may result.

1. Turn off the lights and shut off the engine. Allow the bulbs and fixtures to cool.
2. Lower the light tower to full DOWN.
3. Loosen the lens channel screws (**Figure 33, 5**) to allow the removal of the lens channel (**Figure 33, 6**).

4. Remove the silicone gasket (**Figure 33, 7**) and lens (**Figure 33, 8**).
5. Remove the support clip screws (**Figure 33, 1**) and support clip (**Figure 33, 2**).
6. Carefully remove the old lamp (**Figure 33, 3**) and install the correct replacement lamp.
7. Clean the reflector (**Figure 33, 4**) and lens.
8. Install the support clip and screws.
9. Install the silicone gasket and lens; replace if damaged or needed.
10. Install the lens channel and screws.
11. Test the new lamp to ensure proper operation.

Tower Corner Guide Block Adjustment

1. Make sure the corner guide block cover plate is on top of the UHMW (plastic) corner friction block and a 3/8 internal star washer is between the block and the mounting flange of the tower. This washer is necessary to ensure a grip between the friction block and the metal flange of the tower.
2. Use 1/8 in. spacers to center the inside tower in the middle of the outside tower (**Figure 34**).
3. Using a .010 in. shim and .020 in. shim for spacers, place a .010 in. shim between the friction block and the inner tower section sides (**Figure 34**).
4. Make sure the inner tower is against the 3/8 in. thick UHMW blocks mounted inside the outer tower and use the .020 in. shim to set the friction block distance from the inner tower section (**Figure 34**).
5. Tighten the 1/4-20 nuts. Continue to set all corner friction blocks on all sections using this procedure.

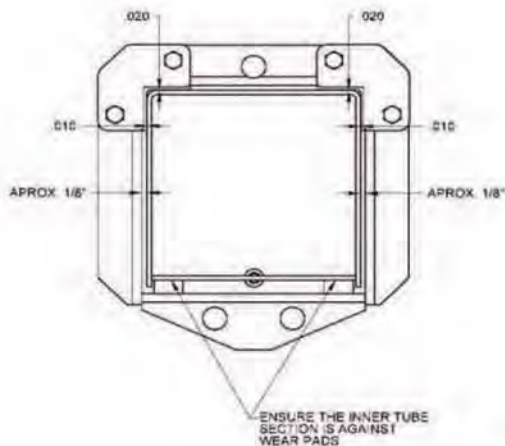

ALB_O_0043

Figure 34

TRAILER

Proper maintenance and care of your trailer is a must for safe and reliable operation. Follow these maintenance and care guidelines in addition to those scheduled by your shop equipment maintenance schedule.

Frame

1. Check the coupler operation and for corrosion or damage; replace as needed.
2. Inspect the lifting bar for corrosion or damage; replace as needed.
3. Inspect the trailer frame and body panels for rust, nicks and chips. Use the proper touch-up paint to touch up nicks or scratches. Contact your dealer for additional information.
4. Inspect the axle, springs and undercarriage for wear and damage; replace as needed.
5. Inspect the outrigger bars, front and rear stabilizer jacks and locking mechanisms for proper operation, wear and damage; replace as needed.
6. Inspect the safety chains for wear and corrosion damage; replace as needed.

Grease Points

Use N.G.L.I. consistency #2 high-temperature anti-friction bearing lubricating grease for all trailer mechanical pivot points.

Trailer Wheels and Tires

WARNING! Towing Hazard. Never tow the trailer with damaged tires, rims or lug nuts.

1. Check the tires for any cracks, cuts or damage. Repair or replace the damaged tires before towing.

2. Check the air pressure of the trailer tires when cold. The correct air pressure for the tire is specified on the tire. Never over- or under-inflate tires.
3. Check the wheel rims for any cracks or damage.
4. Make sure all the lug nuts are in place. Never tow the trailer with missing or improperly tightened lug nuts.
5. Check that the lug nuts are tightened properly. The correct torque for the lug nuts is 90 lb-ft (122 N-m).
6. When torquing lug nuts, always use a criss-cross pattern (**Figure 35**).

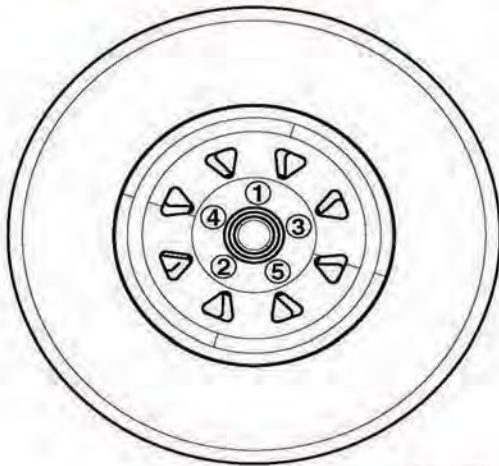
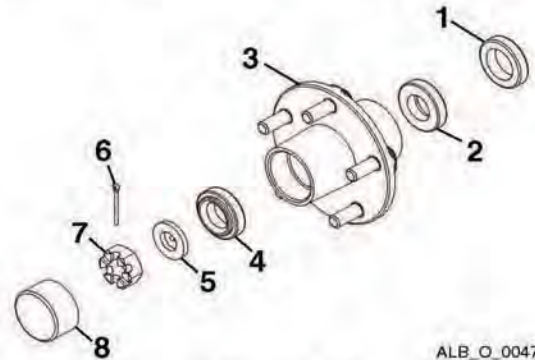

Figure 35

ALB_O_0042

Wheel Bearings

Typical Wheel Hub Bearing Assembly



ALB_O_0047

Figure 36

- 1 –Hub Grease Seal
- 2 –Inner Hub Wheel Bearing
- 3 –Wheel Hub
- 4 –Outer Hub Wheel Bearing
- 5 –Washer
- 6 –Cotter Pin
- 7 –Castle Nut
- 8 –Dust Cover

Wheel bearings require periodic maintenance and scheduled replacement; more frequent service may be required under extremely dusty or damp operating conditions. The best protection against failure is to keep the wheel bearings clean and fully lubricated.

When replacing or repacking wheel bearings, always:

- Use a high-quality wheel bearing grease.
- Avoid mixing grease types.
- Clean all components thoroughly of all grease and inspect for damage and wear; replace as needed.
- Always use a new grease seal and cotter pin.
- Keep all components clean during assembly.

- Replace any component that is operationally questionable.
- Always replace bearings and races as a set. Never mix bearings and races. Bearing part numbers are sometimes found on the bearing races; always use the correct bearing set.
- Pack grease into the bearing before installing it.
- Do not over- or under-tighten the bearing nut. Wheel bearings should only be tightened by hand (spin the wheel while tightening). Back off the nut to insert the cotter pin. The wheel should spin freely but without play.
- Pack some grease in the inner hub area and dust cap and ensure the dust cap fits tightly.

Trailer Lighting

WARNING! Towing Hazard. Never tow the trailer with inoperable trailer lights.

Lights are a vital safety feature of your trailer and are also required by state law. Keep the lights in proper working order.

- Check the trailer lights and harness for damage or wear; repair or replace as needed.
- Ensure the harness is secured to the trailer and does not hang down onto the ground.
- Check the taillight housing assemblies for damage or leaks. Use silicone or rubber sealant to seal the lens or harness, as required, or replace the housing assembly. Electrical grease will help protect the sockets and prevent their corrosion.
- When replacing bulbs, ensure the proper bulb is used and use a small amount of electrical grease in the sockets to prevent corrosion.

For trailer light wiring schematic information, see *Taillamp Wiring* on page 53.

LONG-TERM STORAGE

Proper maintenance is required when the light tower and trailer will be stored or removed from operation for long periods of time.

Refer to the *Engine Operator's Manual* and the *Generator Operator's Manual* for all engine and generator long-term storage procedures.

1. Lower the light tower to the full DOWN position.
2. Make any repairs necessary to ensure the equipment is fully functional upon recommissioning.
3. Clean and wash the frame and body panels. Apply an anticorrosion coating to all surfaces where applicable.
4. Clean any oil or liquid spills inside the engine compartment.
5. Clean all electrical wiring and components by hand using a non-corrosive cleaner.
6. Clean the light tower and light fixture assemblies.
7. Disconnect and remove the battery.
8. Use a suitable cover to protect the light tower and trailer.
9. Properly support the trailer axle on jack stands or other suitable supports to allow the tires to remain off the ground during storage.

CLEANING

Keeping the light tower clean is important to ensure proper operation. Dirt and dust buildup acts as an insulator and may cause the engine, generator and light assemblies to operate at excessively high temperatures.

Use the following as cleaning guidelines:

- Use caution when using compressed air or water / steam pressure washers. Do not pressure - clean electrical components, as this may damage electrical components.
- Clean the light tower and remove all dust dirt or other foreign material.
- Inspect and clean the cooling air intake and exhaust louvers of the enclosure. Make sure they are clean. Remove dirt or any buildup that may restrict the cooling air flow.
- Clean the light tower and its components with a damp cloth or sponge.
- Inspect and clean all engine linkages so they operate properly.

Cleaning and Draining the Trailer bilg - (Artic Specials Only)

All Allmand **NIGHT LITE PRO** light towers contain a sealed bilge designed to catch fuel, oil or coolant spills. Should a spill occur, position a suitable container beneath the unit and remove the bilge drain plug. After the fluid has been drained, reinstall the drain plug and dispose of the fluid properly in accordance with EPA or other governmental guidelines.

Before performing any troubleshooting procedures, read the following safety messages and read *Safety on page 8*.

For engine and generator troubleshooting, see the *Engine Operator's Manual* and *Generator Operator's Manual* or contact your dealer.

The safety messages that follow have WARNING level Electrocutation Hazards.

- **Only qualified, licensed electricians should service or perform replacement procedures. Ballast and capacitors are capable of discharging high voltage. Always use appropriate personal safety clothing and gear when servicing electrical components.**

- **High voltage is present when engine is running. Never attempt to service electrical components while engine is running.**
- **Do not operate the light tower if the insulation on the electrical wiring is cut or worn, or if bare wires are exposed. Repair or replace damaged wiring before starting the engine.**

Always follow the electrical component manufacturer specifications for voltage and test procedures.

TROUBLESHOOTING CHART

PROBLEM	POSSIBLE CAUSE
NO LIGHT (ONE OR MORE LIGHTS)	1. Circuit breakers in the outlet box are not turned on or have tripped.
	2. Lamps are not allowed time to cool after last being lit. You must allow 15 minutes between the time the lights are shut off and the time they are restarted.
	3. The lamp or lamps are burned out or broken.
	4. One or more of the lamps are not screwed in securely.
	5. Plug and socket at light bar not securely pushed together and locked.
	6. The temperature of the ballast is below -20°F (-29°C). The efficiency of the capacitors in the ballast is not enough to ignite the lamps. For operations where the temperature of the ballast falls below -20°F (-29°C), some means of warming the ballast must be used.
	7. Low electrical system voltage.
	8. A loose connection in the back of the lamp socket in the lamp holder.
	9. A circuit breaker or breakers are defective.
	10. A loose connection on the terminal board.
	11. The engine and generator are not running up to speed (1800 RPM)
	12. A wrong style replacement lamp (requiring a different ballast) has been installed.
	13. Too much power is being drawn from the auxiliary outlets.
	14. Capacitor or transformer has failed.
	15. Corrosion has occurred on the lamp bases.

MAINTENANCE RECORD

5/24/2011

DATE	SERVICE DESCRIPTION	SERVICED BY

KUBOTA W/ RELAY CONTROL WIRING SCHEMATIC 5/24/2011

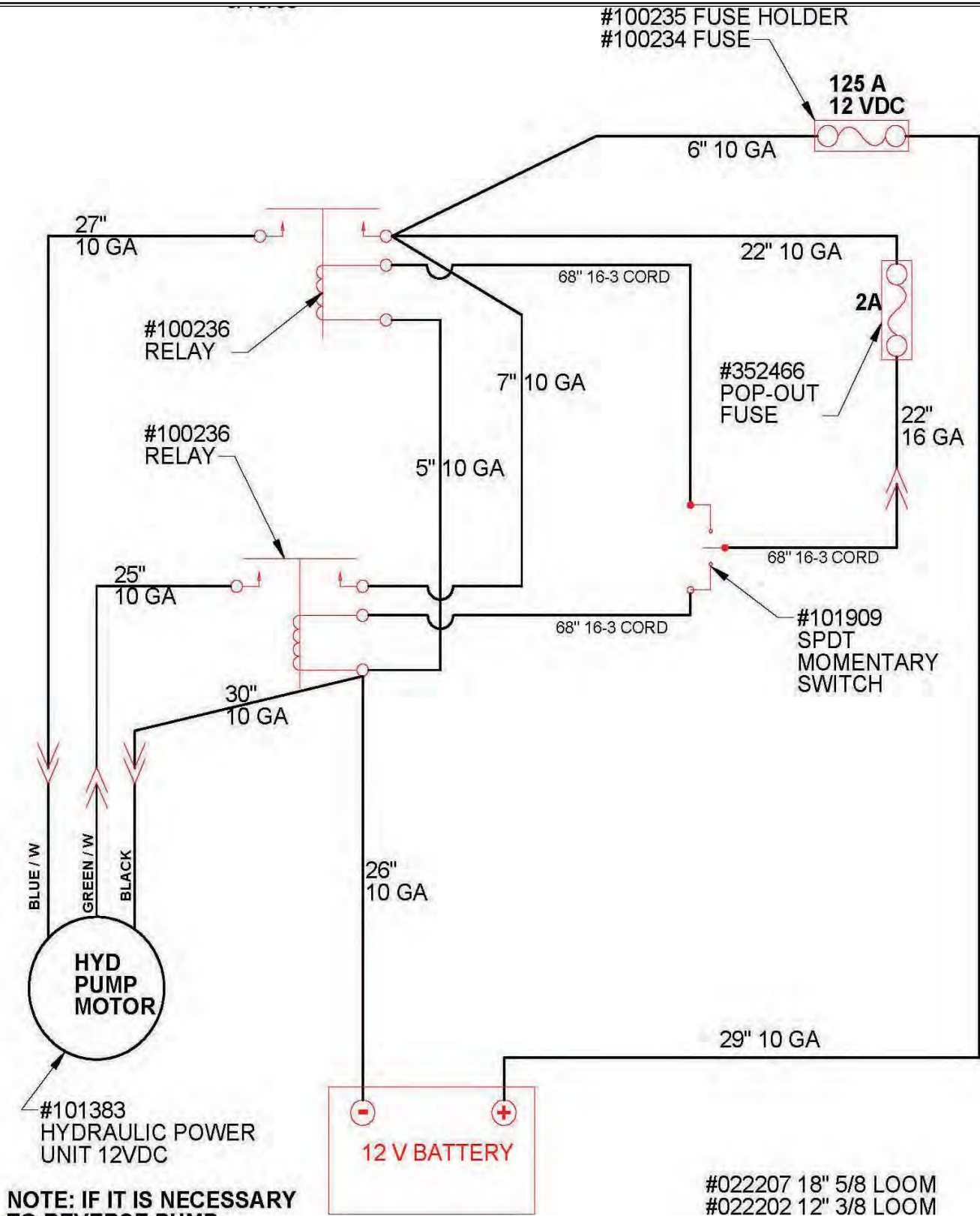

COMPONENTS

KUBOTA GUAGE PANEL WIRING SCHEMATIC

5/24/2011

ALLMAND 1105 WIRING SCHEMATIC
WITH KUBOTA TIMER MODULE
LAST UPDATED 01/06/11

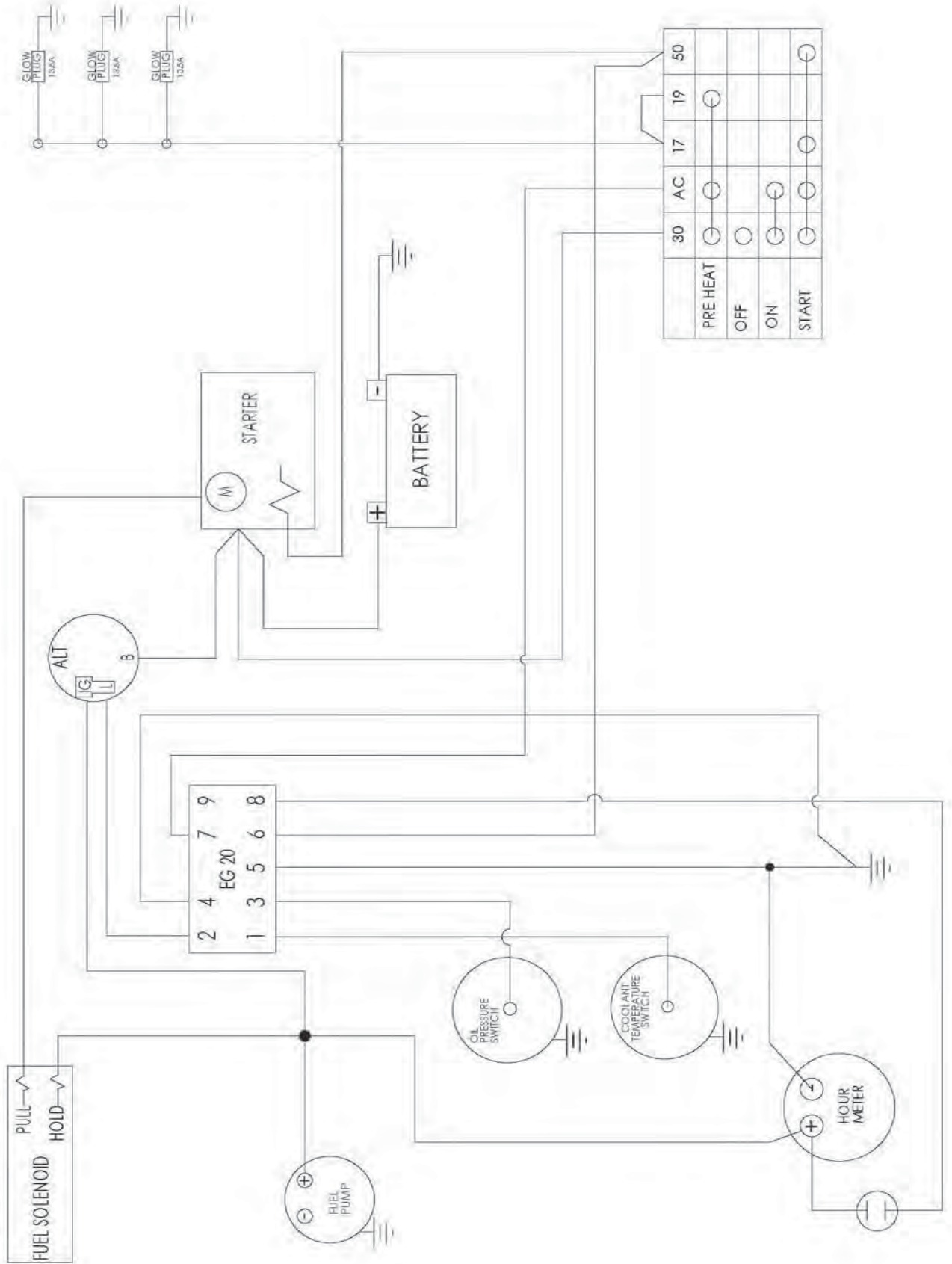

CAT C1.1 ENGINE WIRING HARNESS

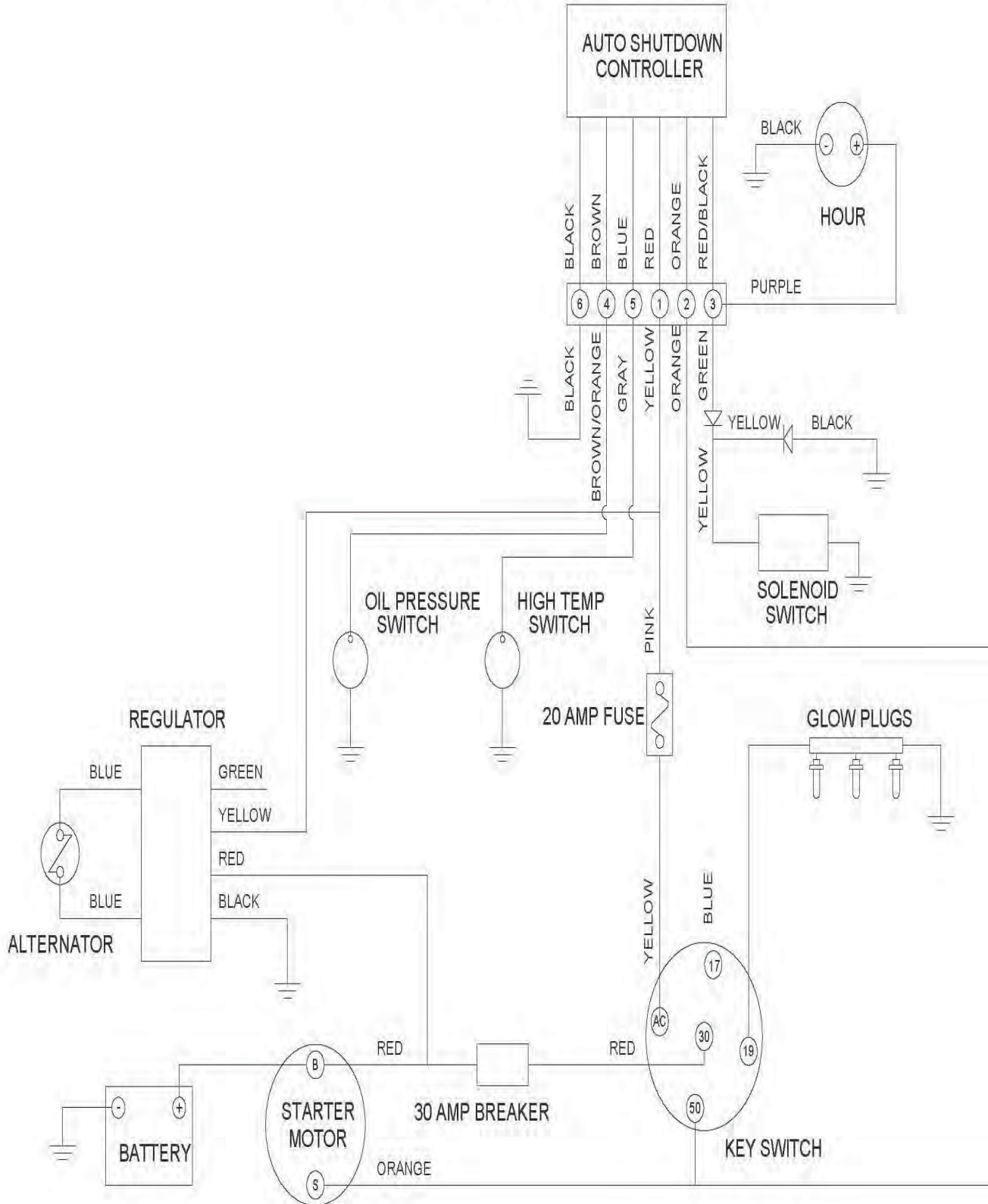

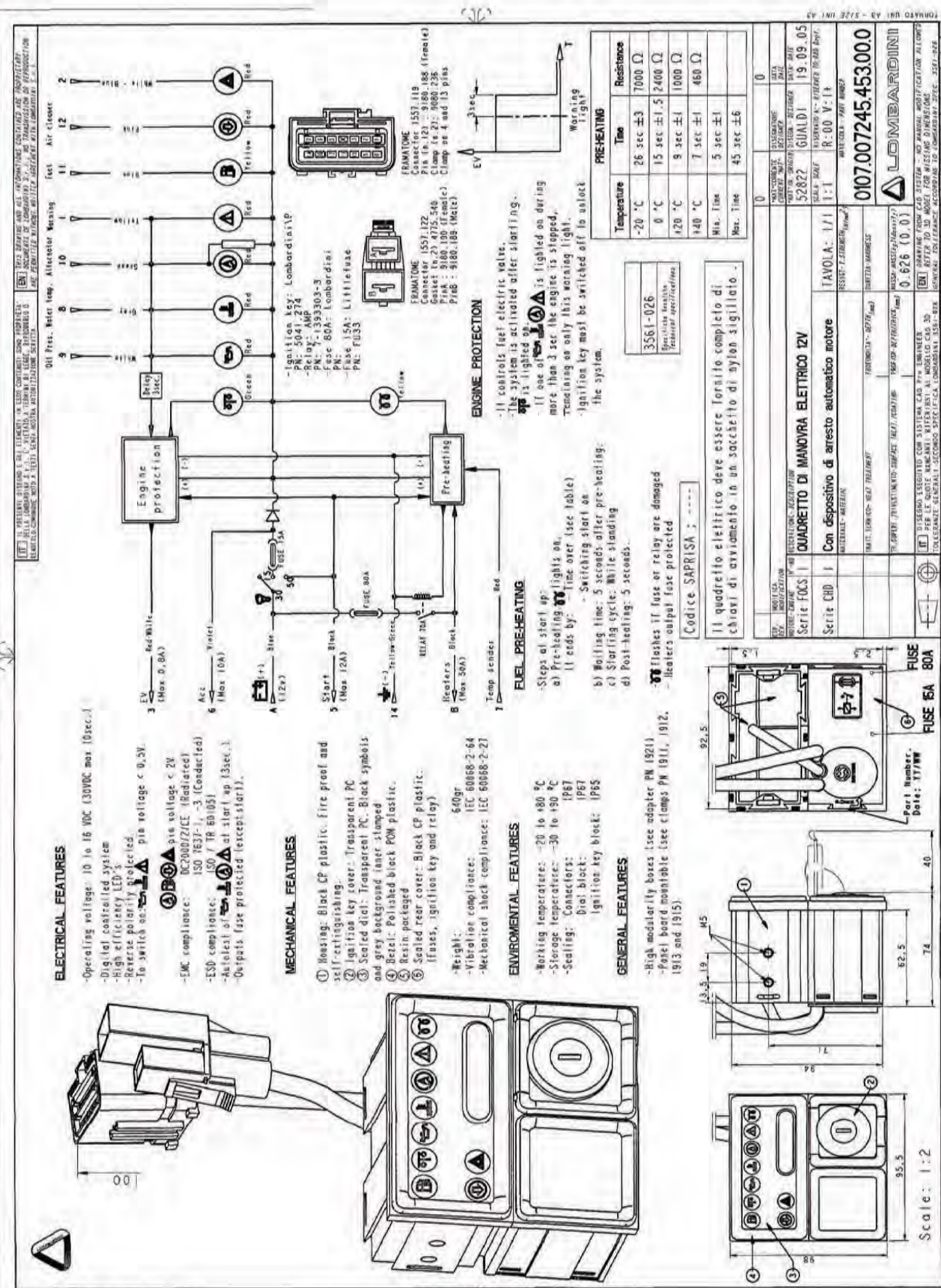

KOHLER ENGINE WIRING SCHEMATIC

5/24/2011

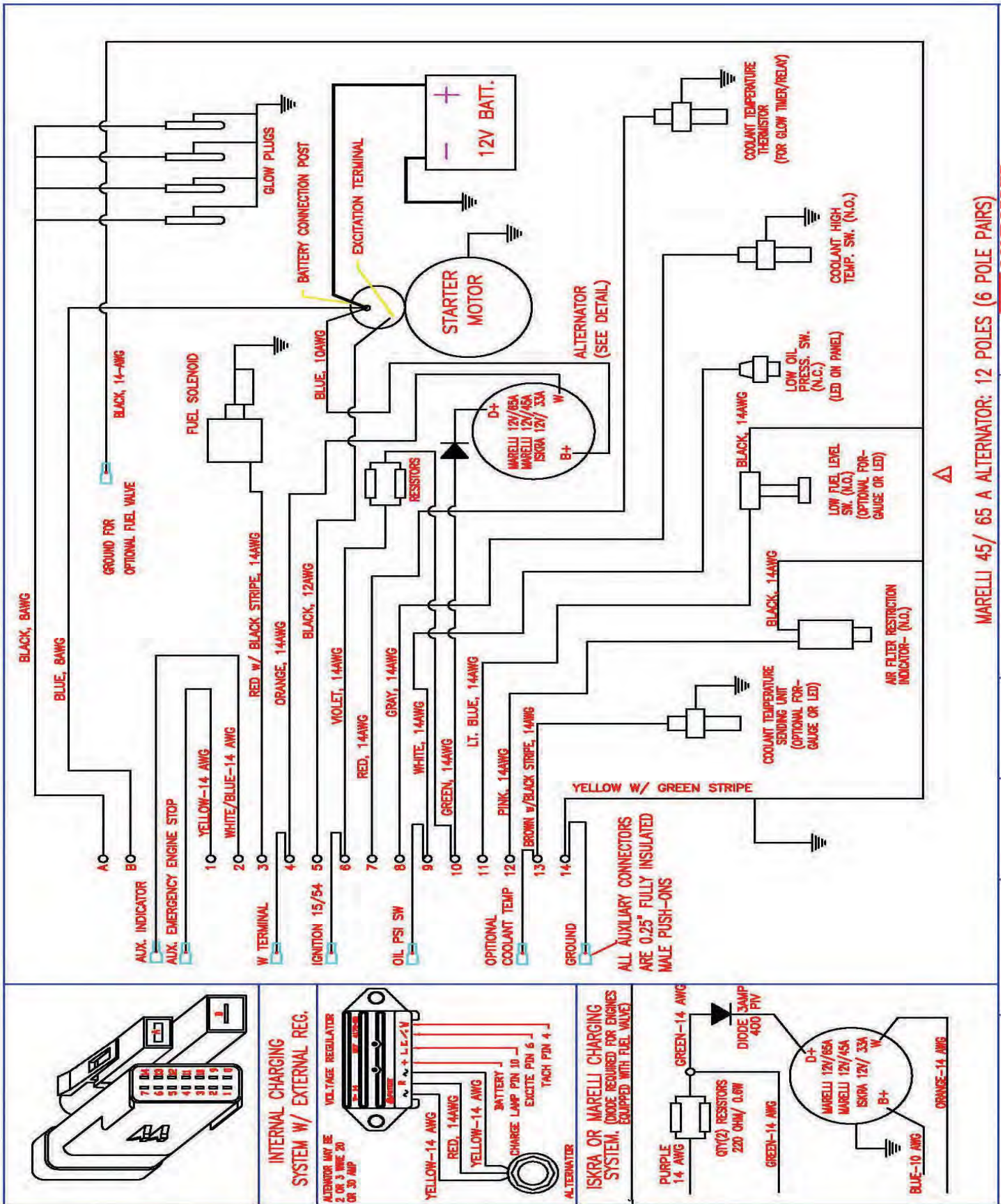

1000W - 50 Hz MECC ALTE GENERATOR

5/24/2011

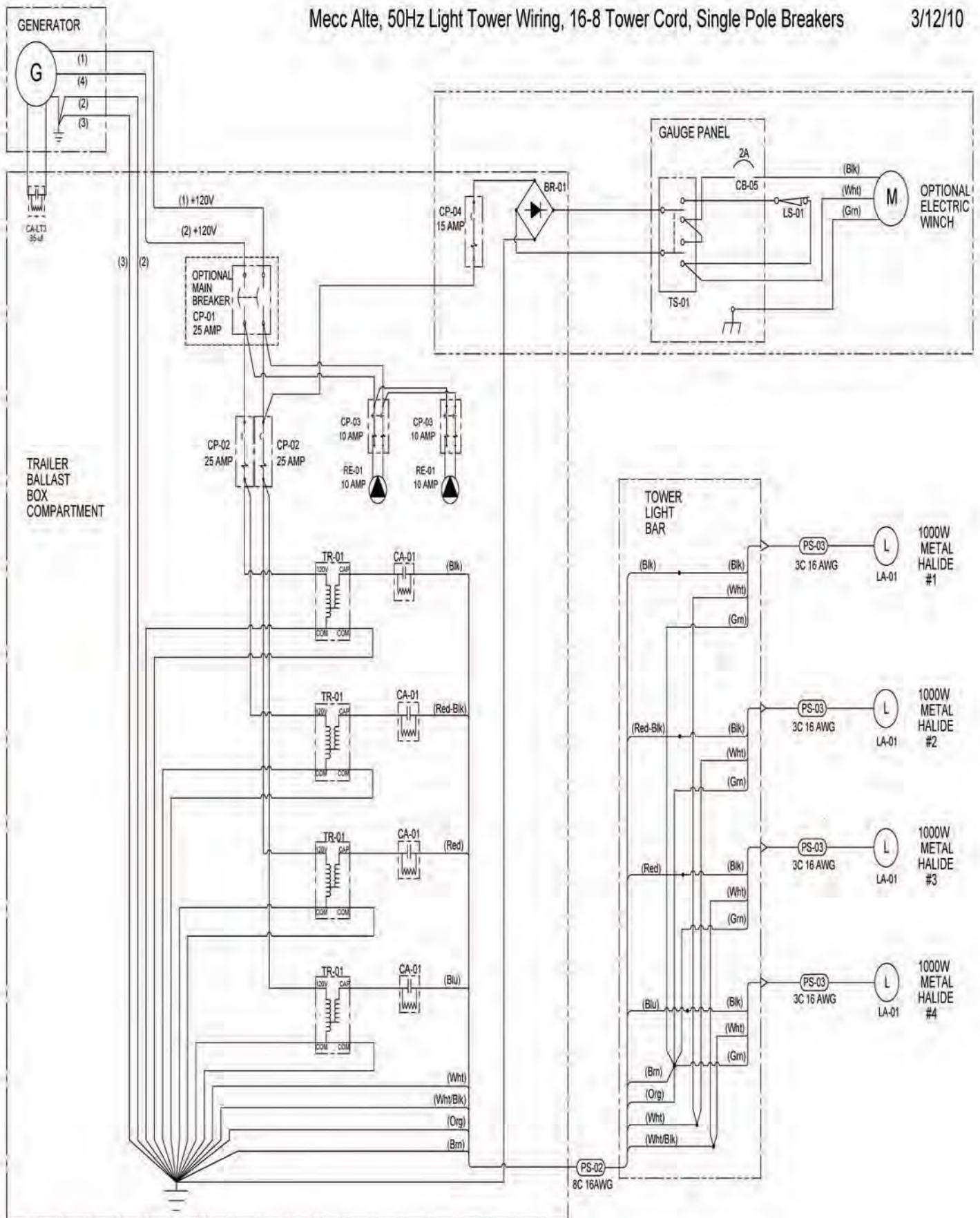

SHO-HD LIGHTING SYSTEM 240 VOLT WIRING SCHEMATIC

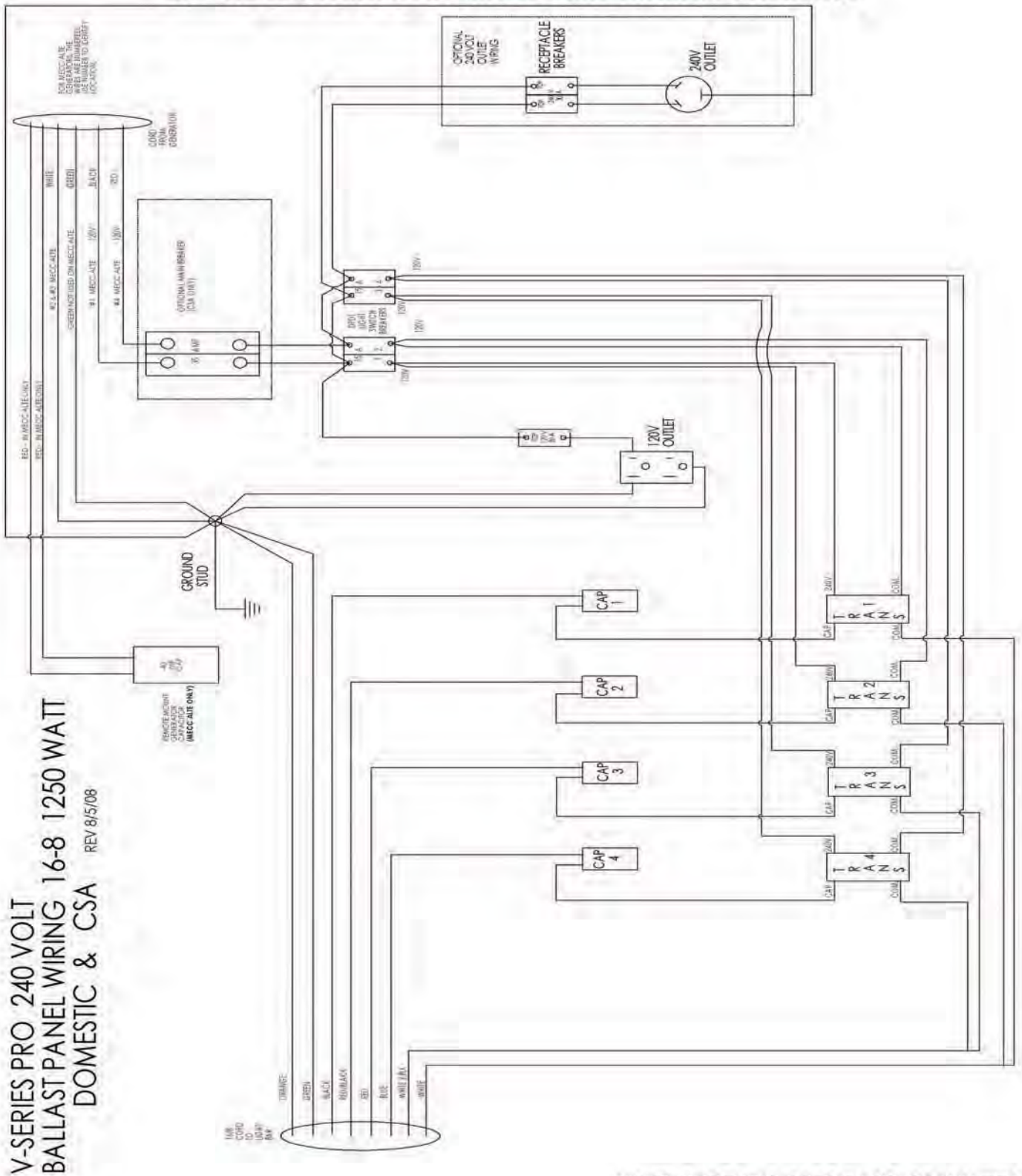

V-SERIES PRO 240 VOLT BALLAST PANEL WIRING 16-8 1250 WATT DOMESTIC & CSA REV 8/5/08

WHEN ORDERING, SPECIFY COLOR WANTED ON PART NUMBERS CONTAINING THE LETTER P

240V - 1250W LIGHT BAR

5/24/2011

V-SERIES PRO 240 VOLT
LIGHT BAR WIRING 16-8 1250 WATT
DOMESTIC & CSA NEW 7/24/08

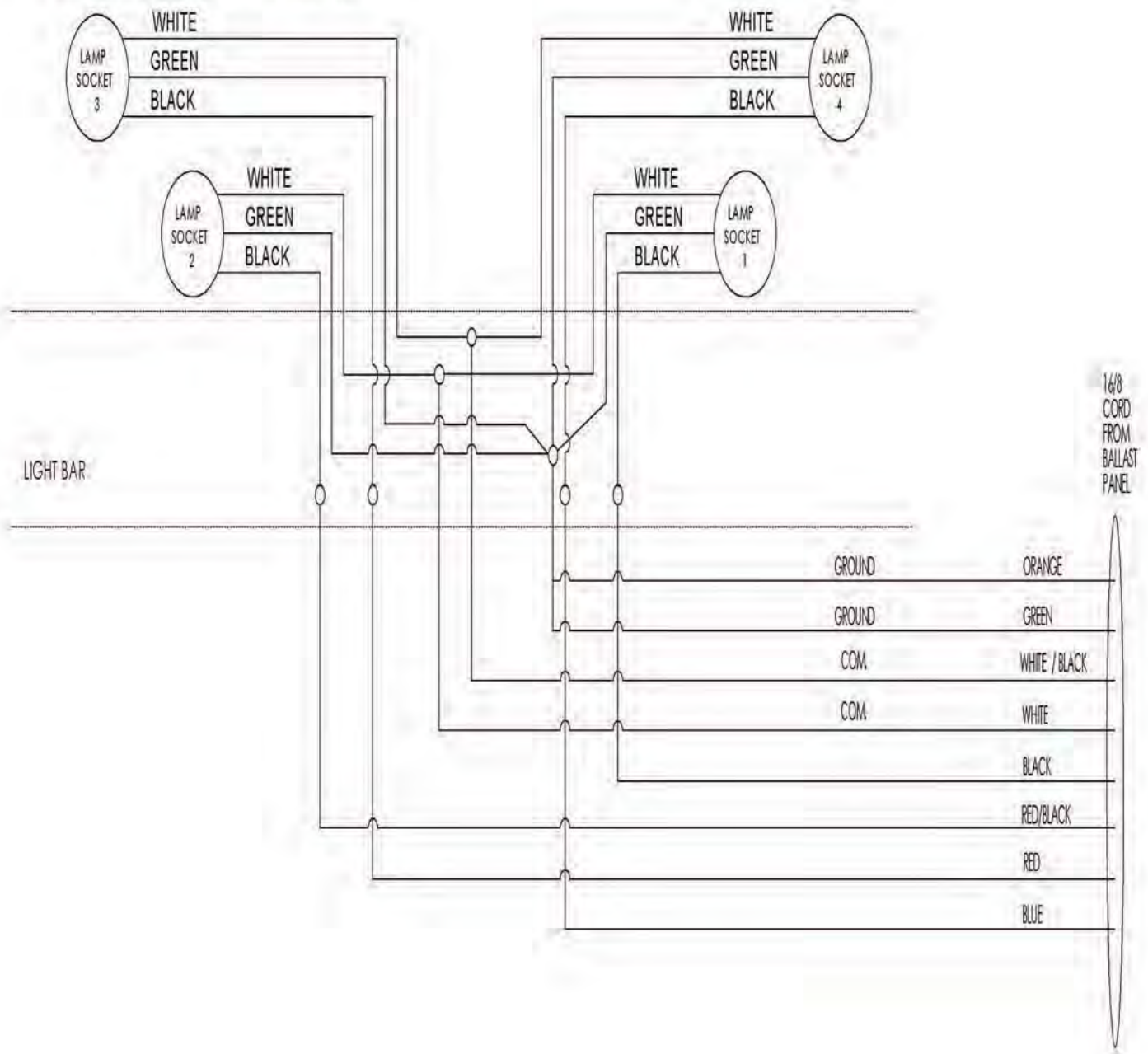

LIGHT BAR

5/24/2011

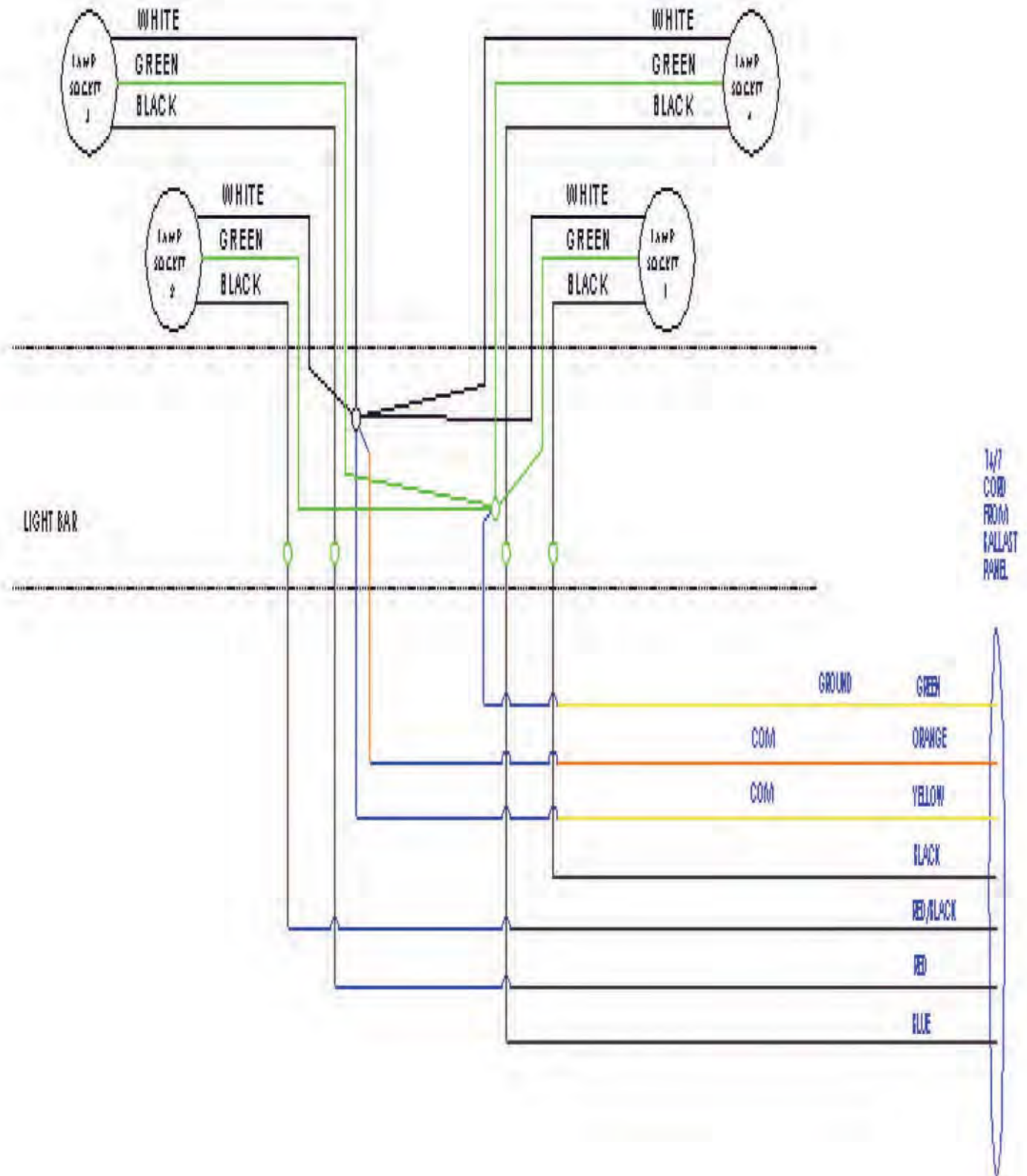

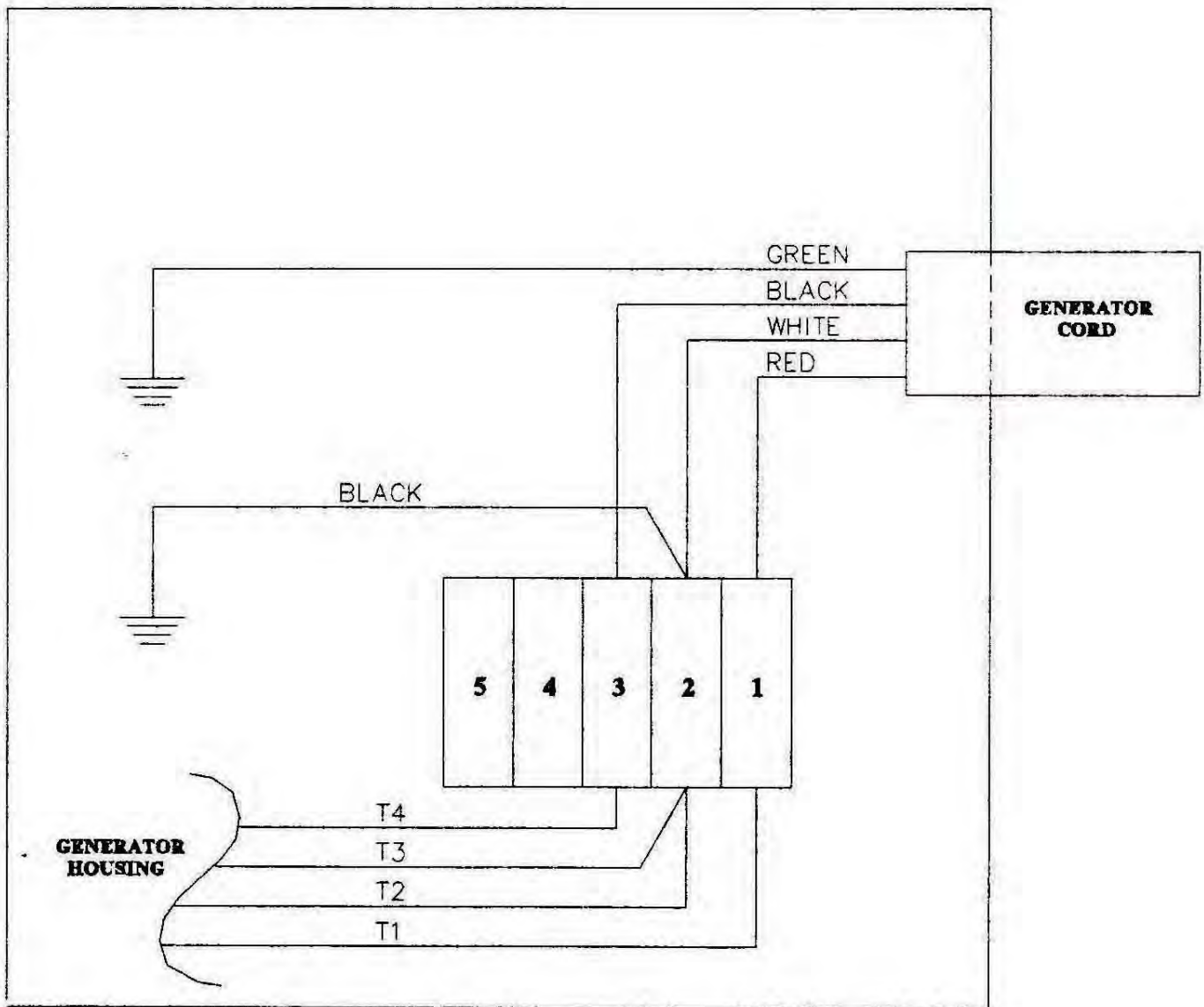

TAILLIGHT WIRING SCHEMATIC

5/24/2011

TAIL LIGHT WIRING

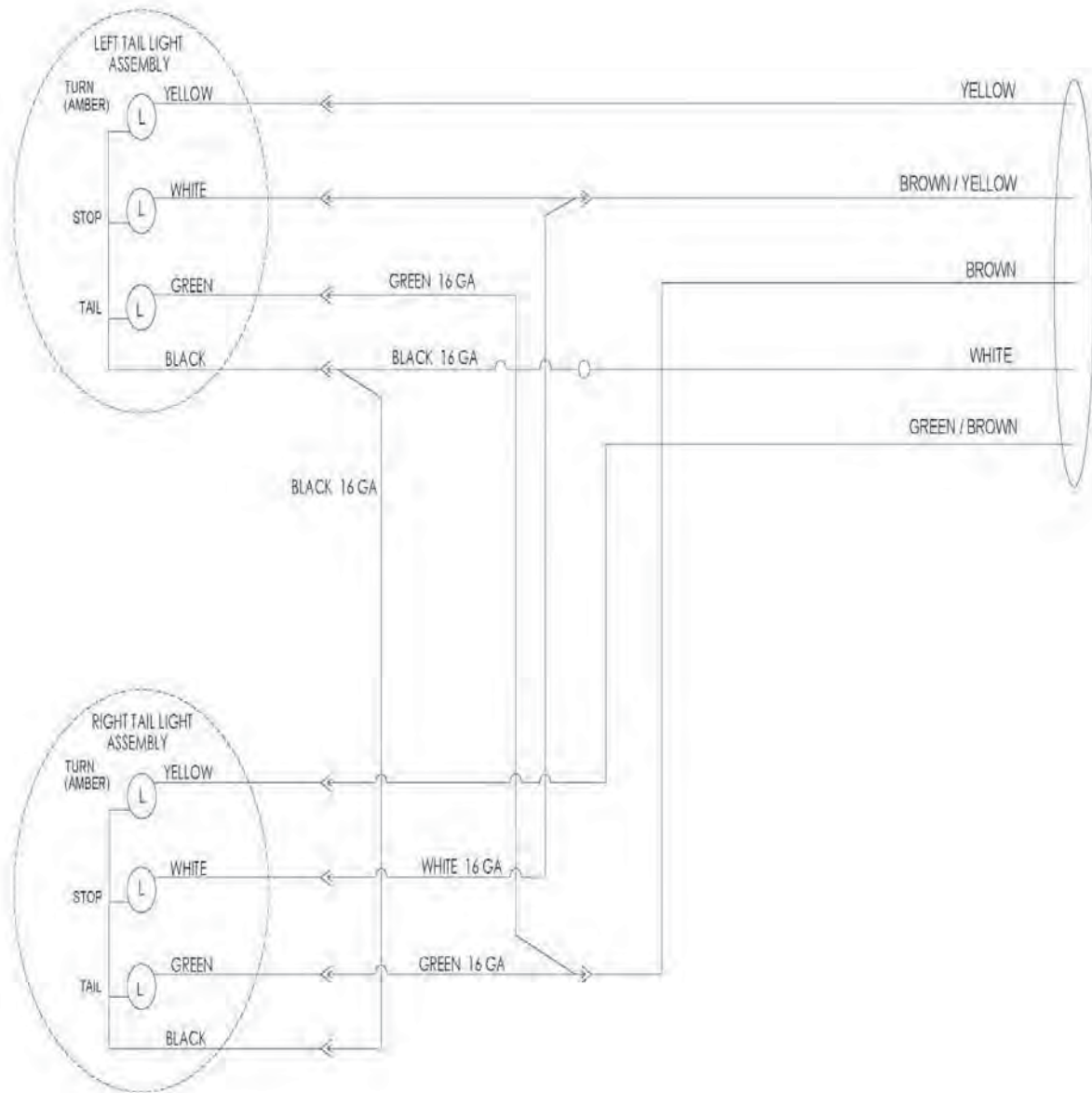

**ALLMAND LIGHTING SYSTEMS
LIMITED WARRANTY
UNITED STATES and U.S. TERRITORIES**

THIS WARRANTY IS IN LIEU OF ALL OTHER WARRANTIES EXPRESSED OR IMPLIED INCLUDING WARRANTIES OF MERCHANTABILITY OR OF FITNESS FOR PURPOSE AND ANY EXCEPTIONS ARE DESCRIBED IN THE PUBLISHED LIMITED WARRANTY ADDENDUM, AVAILABLE UPON REQUEST.

COMPONENTS, SUB-ASSEMBLIES, AND DEVICES MANUFACTURED BY OTHER MANUFACTURERS ARE NOT COVERED BY THIS WARRANTY. ALL WARRANTY INFORMATION FROM SUCH OTHER MANUFACTURERS IS PROVIDED WITHIN OR ACCOMPANIES THESE GOODS.

Subject to the foregoing, the manufacturer, Allmand Bros. Inc., hereby warrants all light towers manufactured by Allmand Bros. Inc. after April 1, 2008 to be free from defects in material and workmanship for a period of (2) years after delivery to the original purchaser. The first year warranty would include parts and labor. The second year warranty would be limited to parts manufactured by Allmand Bros. Inc. and components warranted by the original equipment manufacturer for more than 12 months. Additionally, Allmand Bros. Inc. hereby warrants all replacement parts supplied by Allmand Bros. Inc. to be free from defects in material and workmanship for a period of 90 days after date of invoice. Delivery shall be deemed for the purposes of this warranty to have occurred no later than five days following the date of sale agreement or invoice unless the purchase agreement or invoice specifically states a later delivery date in which case such delivery date shall control. The original purchaser shall be deemed to be a person who places the goods or products in actual use, and any person holding such goods solely for wholesale or retail sale purposes shall not constitute an original purchaser. PROVIDED, any leasing of these goods or other use beyond normal demonstration of same shall be deemed to be in use by an original purchaser and all warranty periods shall commence at the time of such use. During the warranty period any defective goods or parts hereof shall be repaired or replaced at manufacturer's discretion. In the event it is necessary to return such goods or parts to the factory, all transportation charges shall be prepaid. The manufacturer shall in no event pay mileage expenses, but will warrant outbound ground freight. The manufacturer shall in no event be responsible for down time and or lost revenue.

The obligations of the manufacturer is solely to repair or replace defective goods or parts or to refund the cost of the same if it is determined by the manufacturer that repair or replacement will not return the goods to proper working order or utility. **THE REMEDIES SET FORTH HEREIN ARE EXCLUSIVE AND MANUFACTURER SHALL NOT BE LIABLE FOR SPECIAL, INDIRECT, OR CONSEQUENTIAL DAMAGES. THE OBLIGATIONS OF THE MANUFACTURER HEREUNDER SHALL IN NO WAY EXCEED THE PRICE OF THE EQUIPMENT OR PART UPON WHICH SUCH LIABILITY IS BASED.**

The warranty shall not extend to tires, lamps, batteries, or parts that have been altered, changed, damaged, or improperly installed, repaired, operated or maintained. Provided, this exclusion shall not apply to installations, repairs or other work done at the manufacturer's plant or under direct manufacturer's supervision. The Operator's Manual, to the extent covered therein, is deemed to set forth the proper procedures for operation, repair, installation, and maintenance of these goods.

No representative, dealer or distributor of the company is authorized to make any changes or exceptions to this warranty unless expressly authorized in writing from the manufacturer. All warranty claims must be filed within thirty (30) days of the failure.

**LIGHTING SYSTEMS
LIMITED WARRANTY ADDENDUM**

THIS IS AN ADDENDUM TO THE BASIC ALLMAND LIMITED WARRANTY OF TWO (2) YEARS AFTER DELIVERY TO THE ORIGINAL PURCHASER.

The following manufacturers limited warranty policy warrants their components to be free from defects in material and workmanship from date of manufacture as follows (see specific manufacturer's warranty for details):

CATERPILLAR	TWO (2) YEAR LIMITED	2000 HOURS
KUBOTA	THREE (3) YEAR LIMITED	3000 HOURS
LOMBARDINI	THREE (3) YEAR LIMITED	3000 HOURS
ISUZU 3CD	TWO (2) YEAR LIMITED	2000 HOURS
ISUZU 4LE	FIVE (5) YEAR LIMITED	5000 HOURS

ADVANCE BALLAST	TWO (2) YEAR LIMITED	--
MARATHON	TWO (2) YEAR LIMITED	1000 HOURS
MECC ALTE	ONE (1) YEAR LIMITED	--
STAMFORD	ONE (1) YEAR LIMITED	--
LIGHT TOWER ASSEMBLY	TEN (10) YEARS	FAILURE TO OPERATE DUE TO CORROSION

No representative, dealer, or distributor of the company is authorized to make any changes or exceptions to this warranty unless expressly authorized in writing from the manufacturer. All warranty claims must be filed within thirty (30) days of failure.

Please call the Allmand Service and Warranty Department for specific manufacturer's warranty terms and schedules. All warranties are subject to change without notice.