

# PARTS MANUAL



***WHITEMAN* SERIES**  
**MODEL CA4HM**  
**WALK-BEHIND TROWEL**  
**(HONDA GX120K1QX2/GX120UT1QX2**  
**GASOLINE ENGINE)**

Revision #5 (1/08/16)

To find the latest revision of this  
publication, visit our website at:  
[www.multiquip.com](http://www.multiquip.com)



THIS MANUAL MUST ACCOMPANY THE EQUIPMENT AT ALL TIMES.

P/N 21692

# TABLE OF CONTENTS

## CA4HM Walk-Behind Trowel

Table Of Contents.....	2
Parts Ordering Procedures.....	3
Explanation Of Code In Remarks Column.....	4
Suggested Spare Parts .....	5
Nameplate And Decals.....	6-7
Quick Pitch™ Handle Assembly .....	8-9
Spider Assembly.....	10-11
Gearbox Assembly .....	12-13
Engine Assembly, 4 Hp Honda (S/N CI0132684 And Below).....	14-15
Engine Assembly, 4 Hp Honda (S/N CI0132685 And Above) .....	16-17
Guard Ring Assembly.....	18-19
Blades & Pan Assembly .....	20-21

## HONDA GX120K1QX2/UT1QX2 ENGINE

Air Cleaner (Dual) Assembly .....	22-23
Camshaft Assembly.....	24-25
Carburetor Assembly .....	26-27
Control Assembly .....	28-29
Crackcase Cover Assembly.....	30-31
Crankshaft Assembly.....	32-33
Cylinder Barrel Assembly .....	34-35
Cylinder Head Assembly .....	36-37
Fan Cover Assembly.....	38-39
Flywheel Assembly.....	40-41
Fuel Tank Assembly .....	42-43
Ignition Coil Assembly .....	44-45
Muffler Assembly.....	46-47
Piston Assembly .....	48-49
Recoil Starter Assembly.....	50-51
Gasket Kit Assembly .....	52-53
Labels Assembly .....	54-55

Terms And Conditions Of Sale — Parts ..... 56

### NOTICE

Specifications and part numbers are subject to change without notice.

# PARTS ORDERING PROCEDURES

## Ordering parts has never been easier! Choose from three easy options:

Effective:  
January 1<sup>st</sup>, 2006

www.multiquip.com



### Order via Internet (Dealers Only):

Order parts on-line using Multiquip's SmartEquip website!

- View Parts Diagrams
- Order Parts
- Print Specification Information



If you have an MQ Account, to obtain a Username and Password, E-mail us at: [parts@multiquip.com](mailto:parts@multiquip.com).

To obtain an MQ Account, contact your District Sales Manager for more information.

Goto [www.multiquip.com](http://www.multiquip.com) and click on **Order Parts** to log in and save!

Use the **internet** and qualify for a **5% Discount** on *Standard orders* for all orders which include complete part numbers.\*

Note: Discounts Are Subject To Change

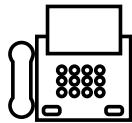

### Order via Fax (Dealers Only):

All customers are welcome to order parts via Fax.

**Domestic (US) Customers dial:**  
1-800-6-PARTS-7 (800-672-7877)

**Fax** your order in and qualify for a **2% Discount** on *Standard orders* for all orders which include complete part numbers.\*

Note: Discounts Are Subject To Change



**Order via Phone: Domestic (US) Dealers Call:**  
1-800-427-1244

### Non-Dealer Customers:

Contact your local Multiquip Dealer for parts or call 800-427-1244 for help in locating a dealer near you.



**International Customers** should contact their local Multiquip Representatives for Parts Ordering information.

## When ordering parts, please supply:

- |   |  |
|---|--|
| <input type="checkbox"/> Dealer Account Number                                | <input type="checkbox"/> Specify Preferred Method of Shipment:                         |
| <input type="checkbox"/> Dealer Name and Address                              | <input checked="" type="checkbox"/> UPS/Fed Ex <input checked="" type="checkbox"/> DHL |
| <input type="checkbox"/> Shipping Address (if different than billing address) | <input type="checkbox"/> Priority One <input checked="" type="checkbox"/> Truck        |
| <input type="checkbox"/> Return Fax Number                                    | <input type="checkbox"/> Ground  |
| <input type="checkbox"/> Applicable Model Number                              | <input type="checkbox"/> Next Day  |
| <input type="checkbox"/> Quantity, Part Number and Description of Each Part   | <input type="checkbox"/> Second/Third Day  |

### NOTICE

All orders are treated as *Standard Orders* and will ship the same day if received prior to 3PM PST.

WE ACCEPT ALL MAJOR CREDIT CARDS!



# EXPLANATION OF CODE IN REMARKS COLUMN

The following section explains the different symbols and remarks used in the Parts section of this manual. Use the help numbers found on the back page of the manual if there are any questions.

**NOTICE**

The contents and part numbers listed in the parts section are subject to change **without notice**. Multiquip does not guarantee the availability of the parts listed.

## SAMPLE PARTS LIST

NO.	PART NO.	PART NAME	QTY.	REMARKS
1	12345	BOLT .....	1	INCLUDES ITEMS W/%
2%		WASHER, 1/4 IN. ....		NOT SOLD SEPARATELY
2%	12347	WASHER, 3/8 IN. ...	1	MQ-45T ONLY
3	12348	HOSE .....	A/R	MAKE LOCALLY
4	12349	BEARING .....	1	S/N 2345B AND ABOVE

## NO. Column

**Unique Symbols** — All items with same unique symbol (@, #, +, %, or >) in the number column belong to the same assembly or kit, which is indicated by a note in the “Remarks” column.

**Duplicate Item Numbers** — Duplicate numbers indicate multiple part numbers, which are in effect for the same general item, such as different size saw blade guards in use or a part that has been updated on newer versions of the same machine.

**NOTICE**

When ordering a part that has more than one item number listed, check the remarks column for help in determining the proper part to order.

## PART NO. Column

**Numbers Used** — Part numbers can be indicated by a number, a blank entry, or TBD.

TBD (To Be Determined) is generally used to show a part that has not been assigned a formal part number at the time of publication.

A blank entry generally indicates that the item is not sold separately or is not sold by Multiquip. Other entries will be clarified in the “Remarks” Column.

## QTY. Column

**Numbers Used** — Item quantity can be indicated by a number, a blank entry, or A/R.

A/R (As Required) is generally used for hoses or other parts that are sold in bulk and cut to length.

A blank entry generally indicates that the item is not sold separately. Other entries will be clarified in the “Remarks” Column.

## REMARKS Column

Some of the most common notes found in the “Remarks” Column are listed below. Other additional notes needed to describe the item can also be shown.

**Assembly/Kit** — All items on the parts list with the same unique symbol will be included when this item is purchased.

Indicated by:

“INCLUDES ITEMS W/(unique symbol)”

**Serial Number Break** — Used to list an effective serial number range where a particular part is used.

Indicated by:

“S/N XXXXX AND BELOW”

“S/N XXXX AND ABOVE”

“S/N XXXX TO S/N XXX”

**Specific Model Number Use** — Indicates that the part is used only with the specific model number or model number variant listed. It can also be used to show a part is NOT used on a specific model or model number variant.

Indicated by:

“XXXXX ONLY”

“NOT USED ON XXXX”

**“Make/Obtain Locally”** — Indicates that the part can be purchased at any hardware shop or made out of available items. Examples include battery cables, shims, and certain washers and nuts.

**“Not Sold Separately”** — Indicates that an item cannot be purchased as a separate item and is either part of an assembly/kit that can be purchased, or is not available for sale through Multiquip.

## SUGGESTED SPARE PARTS

### CA4HM WALK-BEHIND TROWEL

1 to 3 Units

Qty.	P/N	Description
3	.0189	GRIP
1	.21046	GASKET KIT
1	.21047	BEARING KIT
1	.1714	PITCH CABLE
1	.10607	THRUST BEARING
1	.10567	THRUST COLLAR
1	.10639	WEAR PLATE
3	.2343	V-BELT (A-25)
1	.0302	CABLE, THROTTLE
2	.10139	GEARBOX LUBRICANT
1	.10936	CABLE ASSY.HAND CLUTCH
4	.10768-1	ARM, TROWEL, W/LEVER

### HONDA GX120K1QX2/GX120UT1QX2 GASOLINE ENGINE

1 to 3 Units

Qty.	P/N	Description
2	.9807955855	SPARK PLUG W16EPR-U (DENSO), OPT(GX120K1QX2)
2	.9807955876	SPARK PLUG BPR5ES (NGK) (GX120UT1QX2)
2	.17631ZH7003	TANK CAP (GX120K1QX2)
2	.17620Z0T813	TANK CAP (GX120UT1QX2 - S/N 1120058 AND BELOW)
2	.17620Z4H000	TANK CAP (GX120UT1QX2 - S/N 1120059 TO 1188057)
2	.17620Z4H010	TANK CAP (GX120UT1QX2 - S/N 1188058 TO 1206680)
2	.17620Z4H020	TANK CAP (GX120UT1QX2 - S/N 1206681 AND ABOVE)
3	.17210ZE0505	AIR CLEANER ELEMENT (GX120K1QX2)
3	.17210ZE0822	AIR CLEANER ELEMENT (GX120UT1QX2)
2	.17218ZE0505	FILTER OUTER (GX120K1QX2)
2	.17218ZE0820	FILTER OUTER (GX120U1QX2)

#### NOTICE

Part numbers on this Suggested Spare Parts list may supersede/replace the part numbers shown in the following parts lists.

# NAMEPLATE AND DECALS

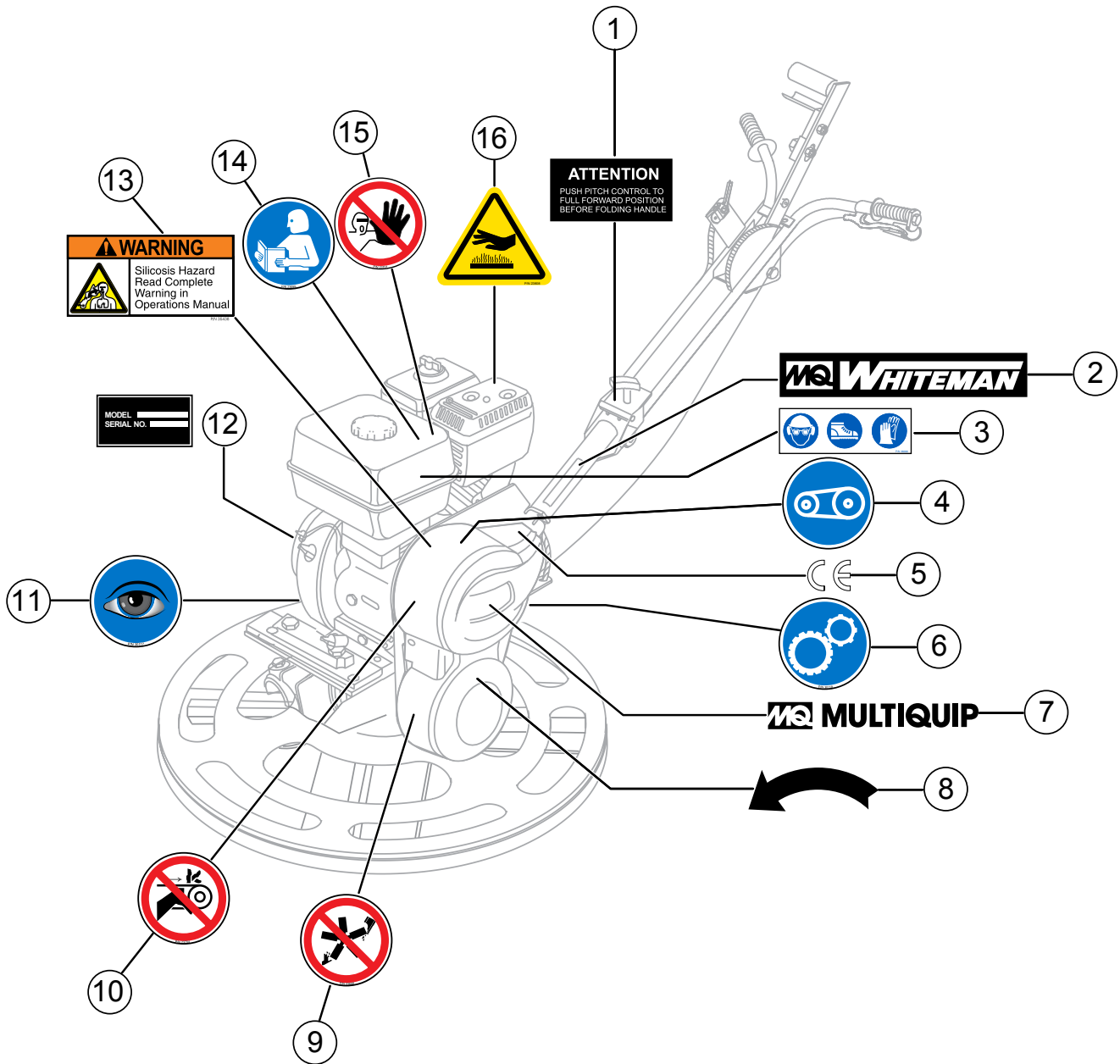

## NAMEPLATE AND DECALS

<u>NO.</u>	<u>PART NO.</u>	<u>PART NAME</u>	<u>QTY.</u>	<u>REMARKS</u>
1	10732	DECAL: CAUTION PITCH HANDLE	1	
2	2942	DECAL: MQ LOGO, WHITE 13"	1	
3	36099	DECAL: PROTECTIVE CLOTHING	1	
4	32553	ISO DECAL: BELT DRIVE, 1.00" DIA.	1	
5	11092	DECAL: CE	1	
6	30118	ISO DECAL: GEAR DRIVE, 2.00" DIA.	1	
7	20816	DECAL: MQ MULTIQUIP	1	
8	25678	ISO DECAL: COUNTER CLOCKWISE	1	
9	23698	ISO DECAL: ROTATING BLADE HAZARD	1	
10	23704	DECAL: WARNING, GUARDS	1	
11	30117	ISO DECAL: EYE, INSPECTION	1	
12		NAME PLATE.....	1	CONTACT MULTIQUIP PARTS DEPARTMENT
13	35438	DECAL: WARNING, SILICOSIS HAZARD	1	
14	23699	ISO DECAL: READ MANUAL	1	
15	23701	ISO DECAL: ASK FOR TRAINING	1	
16	23808	ISO DECAL: HOT SURFACE HAZARD	1	

# QUICK PITCH™ HANDLE ASSY.

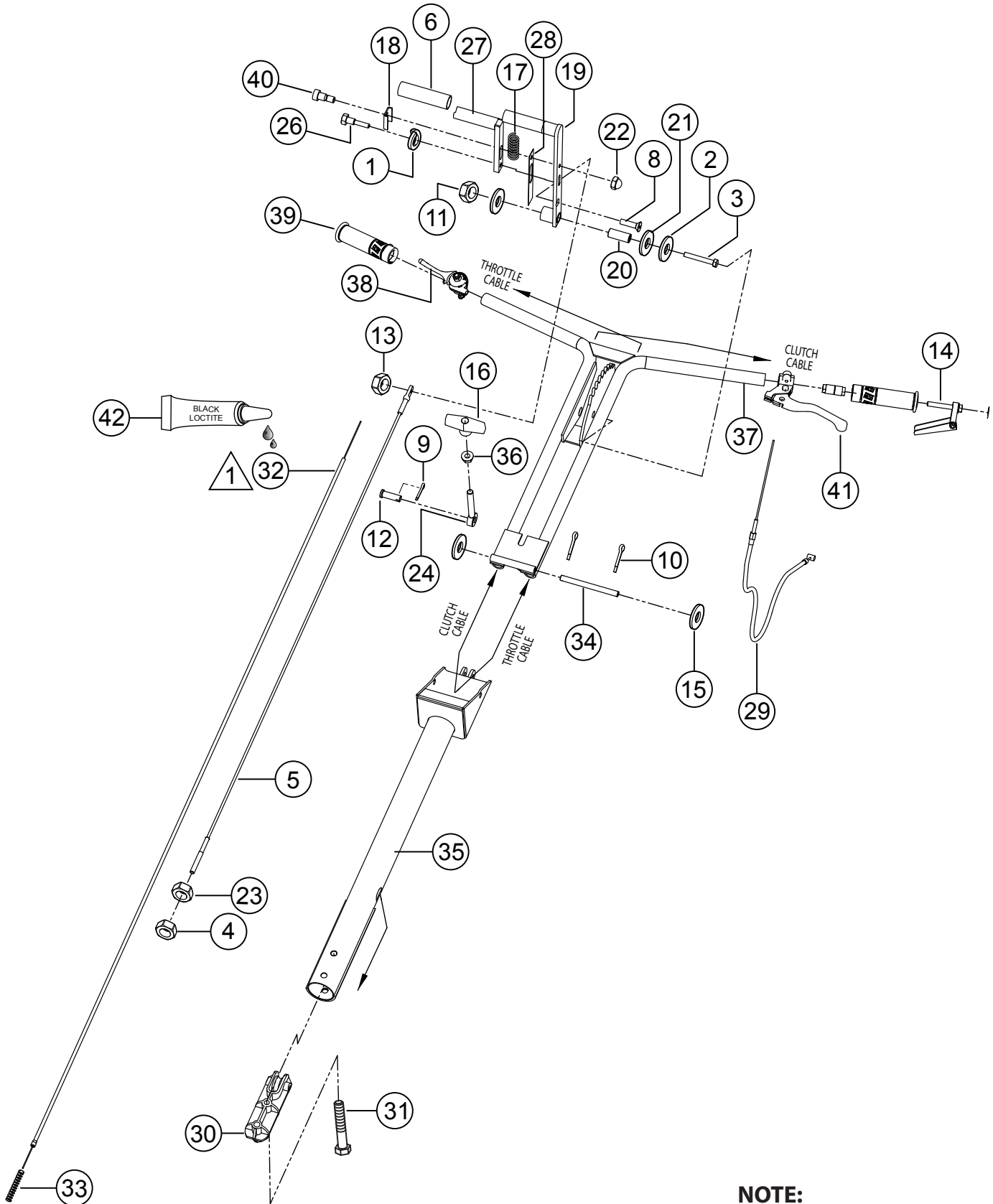

**NOTE:**

**1** LOCTITE #380 BLACK



## QUICK PITCH™ HANDLE ASSY.

<u>NO.</u>	<u>PART NO.</u>	<u>PART NAME</u>	<u>QTY.</u>	<u>REMARKS</u>
1	0161 C	LOCK WASHER 5/16"	1	
2	0300 B	FLAT WASHER 5/16"	2	
3	0669 A	SCREW, HHC 5/16- 18 X 2-1/4"	1	
4	1116	NUT, BRASS, JAM, 5/16-18	1	
5	1714	CABLE, PITCH CONTROL	1	
6	1724	GRIP, HANDLE	1	
8	3164	SCREW, FHSC 1/4- 20 X 1"	1	
9	3216	COTTER PIN	1	
10	5117	PIN, COTTER, 1/16 D X 1/2"	2\	
11	5283	LOCK NUT 5/16- 18	1	
12	5291	CLEVIS PIN	1	
13	10024	LOCK NUT 1/4- 20	1	
14	10036	CLUTCH ASSIST HANDLE ASSY.	1	
15	10136	FLAT WASHER 3/8"	2	
16	10651	TEE HANDLE	1	
17	10654	LATCH RETURN SPRING	1	
18	10655	LATCH RETURN SPRING COVER	1	
19	10657	PITCH CONTROL HANDLE	1	
20	10658	CONTROL HANDLE SUPPORT TUBE	1	
21	10660	SHIM, 1.125" O.D. X .75" I.D. X .031"	1	
22	10676	ACORN NUT 5/16- 18	1	
23	10698	NUT, 15/16-18 CONICAL	1	
24	10701	SWING BOLT	1	
26	10878	QP LATCHING BOLT	1	
27	10881	LATCHING BAR	1	
28	11015	HANDLE SLIDER	1	
29	11097	CABLE, ASSY., B HAND CLUTCH	1	
30	20280	SUPPORT BLOCK	1	
31	21017	SCREW, HHC 3/8- 16 X 3.25 FULL THRD	1	
32	21726	CABLE, ASSY., 68"	1	
33	21746	SPRING, PRIMARY THROTTLE RETURN	1	
34	21758	PIN, HINGE, CA4 HANDLE	1	
35	21779	HANDLE, LOWER CA4	1	
36	21781	NUT, FLANGED HEX, 3/8-16 PLTD	1	
37	21788	HANDLE, UPPER	1	
38	22732	THROTTLE LEVER, ASM.	1	
39	22762	GRIP, HANDLE, 0.875 W/0.63 HOLE	2	
40	3910382	SHOULDER BOLT 3/8 X 3/8	1	
41	1512	CLUTCH HAND LEVER	1	
42	60113	LOCTITE, #380 BLACK	1	

# SPIDER ASSY.

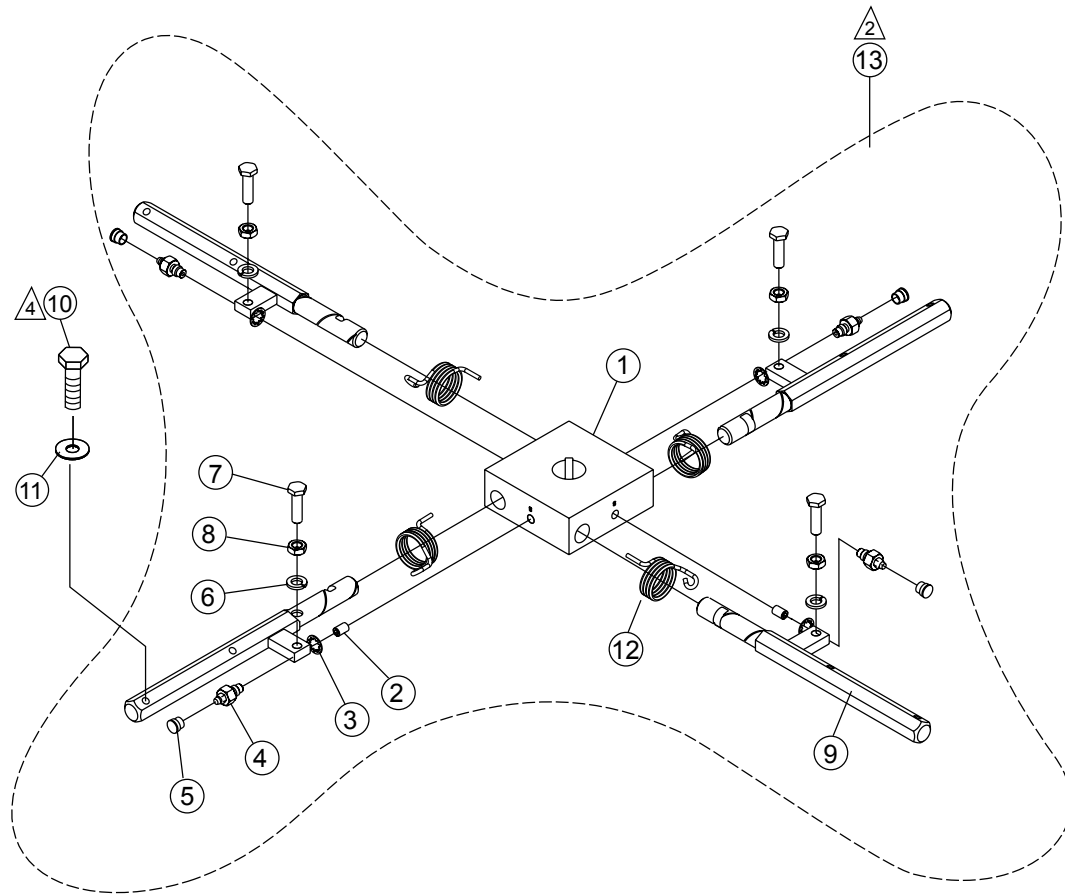

NOTES:

① APPLY LOCTITE P/N 1477 TO ITEMS 1.

② SPIDER ASSEMBLY P/N 11860  
② INCLUDES ALL ITEMS WITHIN OUTLINE.

③ INCLUDED WITH ITEM 15 OR CAN BE  
ORDERED SEPARATELY (P/N 1471)

④ TORQUE TO 130 FT.-LBS (176 Nm)

## SPIDER ASSY.

---

<u>NO.</u>	<u>PART NO.</u>	<u>PART NAME</u>	<u>QTY.</u>	<u>REMARKS</u>
1	10563	SPIDER PLATE, 1-1/8 SHAFT 4BLD CA4	1	
2	11299	SCREW, SHS 5/16-18 X 9/16 CONE PT	2	
3	1875	WASHER, INT. SHKP, 3/8	4	
4	10587	ARM RETAINING ASSY, SHORT	4	
5	1162 A	CAP, GREASE ZERK #2 YELLOW	4	
6	0166 A	WASHER, LOCK, 3/8 MED.	4	
7	0164 B	SCREW, TROWEL ADJUSTMENT 3/8-16	4	
8	1876	NUT, HEX JAM 3/8-16 CLASS 2B	4	
9	10768	ARM, TROWEL W/A	4	
10	10790	SCREW, HHC M6- 1 X 30MM	8	
11	0181 B	LOCK WASHER 1/4"	8	
12	30148	SPRING, TROWEL ARM CA4	4	
13	11860	SPIDER ASM.....	1.....	INCLUDES ITEMS W/*

# GEARBOX ASSY.

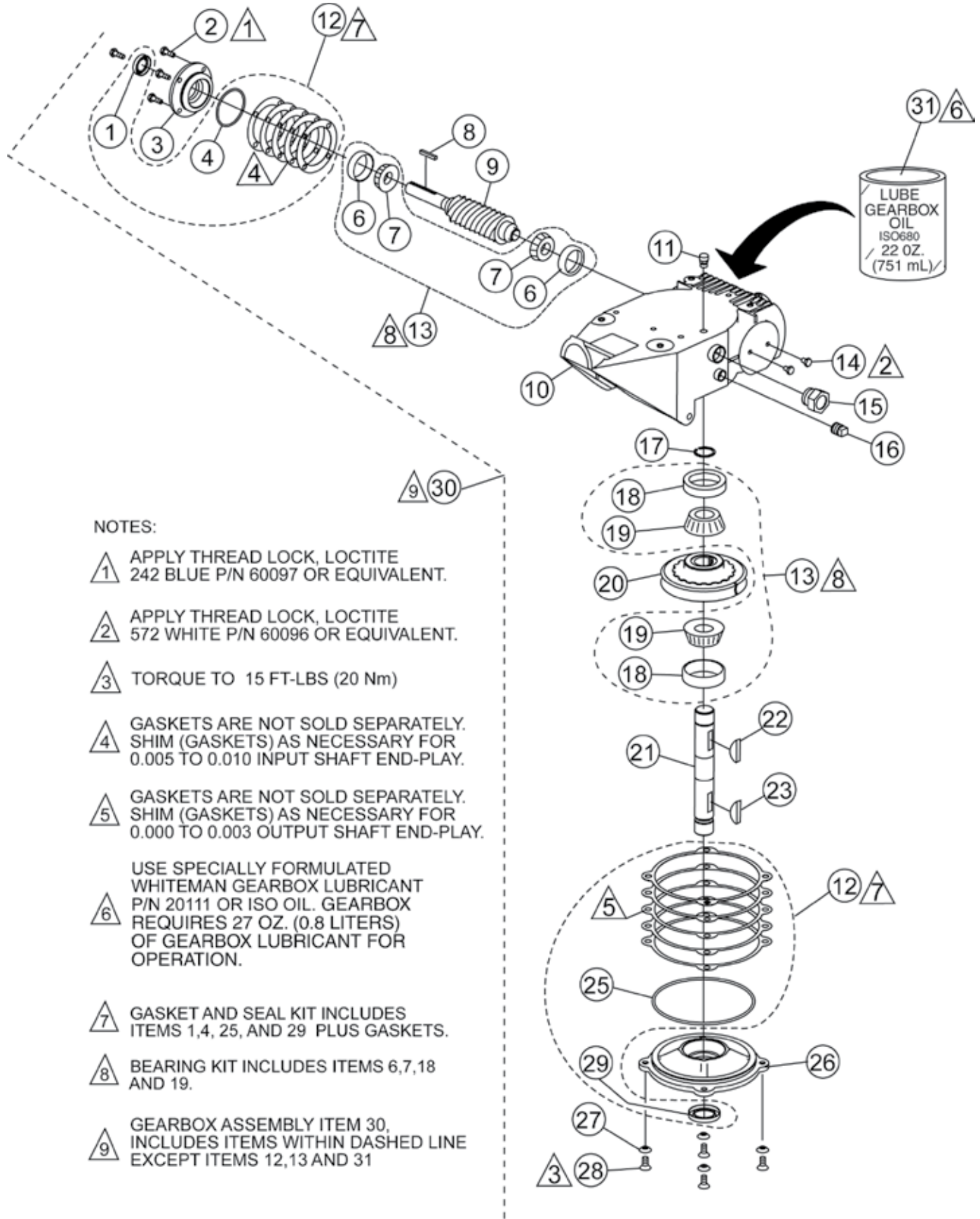

**NOTES:**

- ▲ 1 APPLY THREAD LOCK, LOCTITE 242 BLUE P/N 60097 OR EQUIVALENT.
- ▲ 2 APPLY THREAD LOCK, LOCTITE 572 WHITE P/N 60096 OR EQUIVALENT.
- ▲ 3 TORQUE TO 15 FT-LBS (20 Nm)
- ▲ 4 GASKETS ARE NOT SOLD SEPARATELY. SHIM (GASKETS) AS NECESSARY FOR 0.005 TO 0.010 INPUT SHAFT END-PLAY.
- ▲ 5 GASKETS ARE NOT SOLD SEPARATELY. SHIM (GASKETS) AS NECESSARY FOR 0.000 TO 0.003 OUTPUT SHAFT END-PLAY.
- ▲ 6 USE SPECIALLY FORMULATED WHITEMAN GEARBOX LUBRICANT P/N 20111 OR ISO OIL. GEARBOX REQUIRES 27 OZ. (0.8 LITERS) OF GEARBOX LUBRICANT FOR OPERATION.
- ▲ 7 GASKET AND SEAL KIT INCLUDES ITEMS 1,4, 25, AND 29 PLUS GASKETS.
- ▲ 8 BEARING KIT INCLUDES ITEMS 6,7,18 AND 19.
- ▲ 9 GEARBOX ASSEMBLY ITEM 30, INCLUDES ITEMS WITHIN DASHED LINE EXCEPT ITEMS 12,13 AND 31

## GEARBOX ASSY.

<u>NO.</u>	<u>PART NO.</u>	<u>PART NAME</u>	<u>QTY.</u>	<u>REMARKS</u>
1%*	0753	SEAL, OIL NATIONAL	1	
2%	0131 A	SCREW, HHC 1/4-20 X 3/4"	4	
3%	12876	FLANGE, INPUT SHAFT	1	
4%*	20395	RING, O -139 BUNA N	1	
6%#	21218	BEARING, CUP, TIMKEN	2	
7%#	20465	BEARING, CONE, TIMKEN	2	
8%	0627	KEY, SQUARE 3/16" X 1-1/4"	1	
9%	1851	GEAR, WORM & SHAFT ASSY.	1	
10%	21454	CASE, GEAR	1	
11%	21218	VENT, AIR	1	
12	21046	GASKET/SEAL KIT.....	1	INCLUDES ITEMS W/*
13	21047	BEARING KIT .....	1	INCLUDES ITEMS W/#
14%	20476	SCREW, HHC 1/4-28 X 3/8"	2	
15%	21033	SIGHT GLASS, 3/4 M PIPE STEEL	1	
16%	0121 A	FITTING, PLUG 3/8 MP SQ HEAD	1	
17%	1138	RING, SNAP, TRUARC 5100-112	1	
18%#	20475	BEARING, CUP TIMKEN	2	
19%#	20474	BEARING, CONE TIMKEN	2	
20%	1140	GEAR, WORM, BRONZE	1	
21%	21435	SHAFT, OUTPUT	1	
22%	1139	KEY, WOODRUFF #21 HARDENED	1	
23%*	1238	KEY, WOODRUFF #25	1	
25%*	20396	RING, O -257 BUNA N	1	
26%	12875	COVER, GEARBOX	1	
27%	10235	WASHER, C/S EXT. SHKP	4	
28%*	1146	SCREW, FHSC 5/16-18 X 1", NYLOC NP	4	
29%*	0254	SEAL, OIL, NATIONAL	1	
30	21436	GEARBOX ASSY., W/OIL .....	1	INCLUDES ITEMS W/%
31	20111	BOTTLE, SYNTHETIC OIL, 22 OZ. (751 mL).....	2	REQUIRES 27 OZ. (798 mL)

# ENGINE ASSY., 4 HP HONDA (S/N CL0132684 AND BELOW)

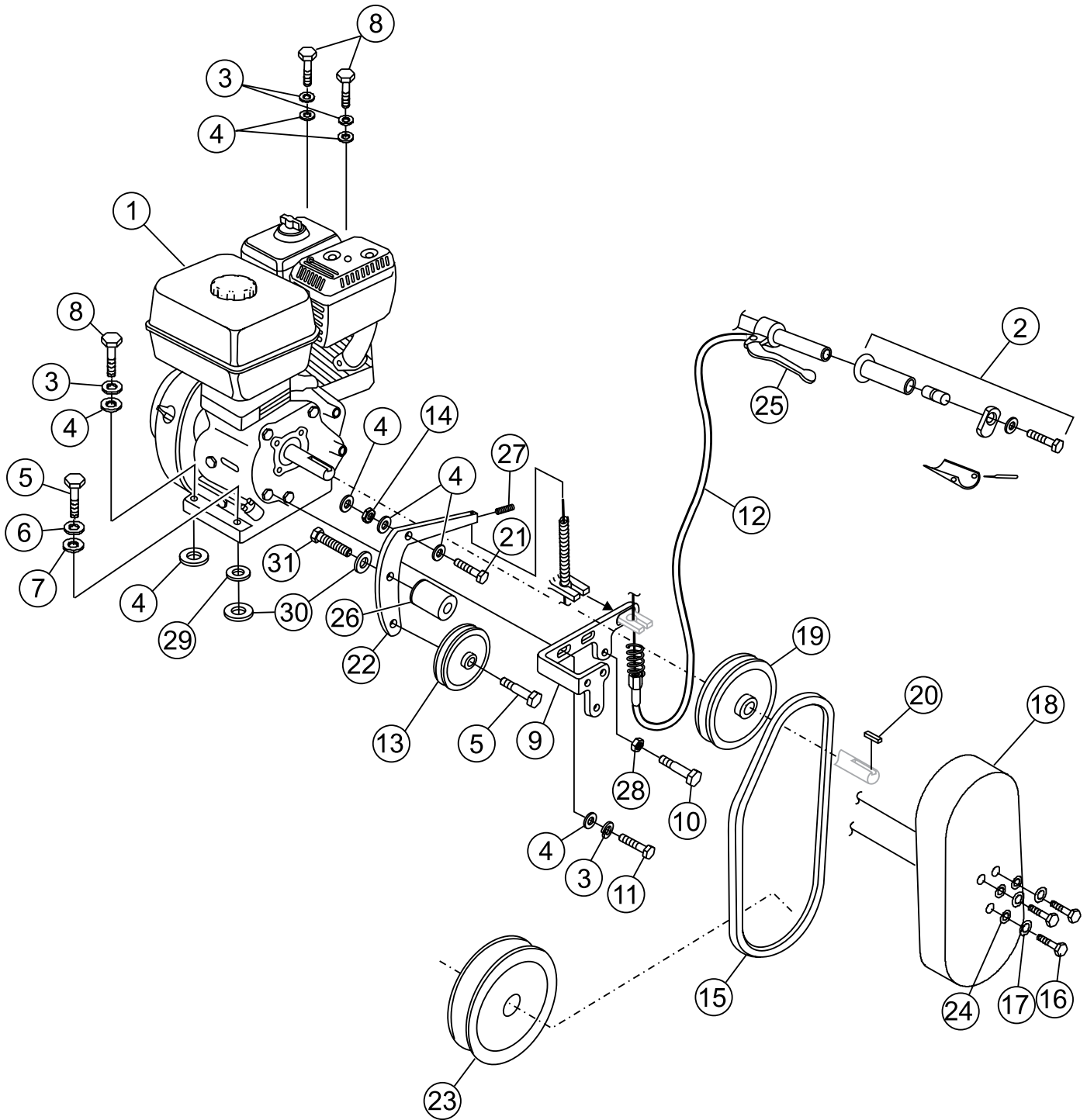

## **ENGINE ASSY., 4 HP HONDA (S/N CL0132684 AND BELOW)**

<u>NO.</u>	<u>PART NO.</u>	<u>PART NAME</u>	<u>QTY.</u>	<u>REMARKS</u>
1	21387	ENGINE, 4 HP. HONDA GX120K1QX2	1	
2	10036	HANDLE ASSY., CLUTCH ASSIST	1	
3	0161 C	LOCK WASHER 5/16"	5	
4	0300 B	FLAT WASHER 5/16"	11	
5	1284	SCREW, HHC 3/8-16 X 1-1/2"	2	
6	0166 A	LOCK WASHER 3/8"	1	
7	10136	FLAT WASHER 3/8"	1	
8	0105	SCREW, HHC 5/16-18 X 1-1/2"	2	
9	10644	CLUTCH BRACKET	1	
10	5277	SCREW, HHC 1/4-20 X 1-1/2"	1	
11	10229	SCREW, HHC 5/16-24 X 1"	2	
12	10936	CABLE ASSY., HAND CLUTCH	1	
13	10608	IDLER PULLEY	1	
14	6014 C	NUT, HEX 5/16-24	1	
15	10611	BELT (A21)	1	
16	0730	SCREW, HHC 1/4-20 X 1"	3	
17	0181 B	LOCK WASHER 1/4"	5	
18	10661	BELT GUARD .....	1	SAFETY ITEM
19	21492	PULLEY	1	
20	10909	SQUARE KEY 3/16" X 3/16" X 13/16"	1	
21	10181	SCREW, HHC 5/16-24 X 1-1/4"	1	
22	20979	CLUTCH LEVER	1	
23	10610	PULLEY	1	
24	0948	FLAT WASHER 1/4"	5	
25	1512	CONTROL LEVER, HAND CLUTCH	1	
26	20981	SHOE, BELT HAND CLUTCH	1	
27	10450	SCREW, SHS 10-32 X 1/4"	1	
28	0949	HEX NUT 1/4-20	1	
29	1733	WASHER, 1/2 X 1/32"	1	
30	13351	WASHER, FLAT USS 3/8" EXT. THK.	1	
31	1672	SCREW, HHC 3/8-24 X 1"	1	

# ENGINE ASSY., 4 HP HONDA (S/N CL0132685 AND ABOVE)

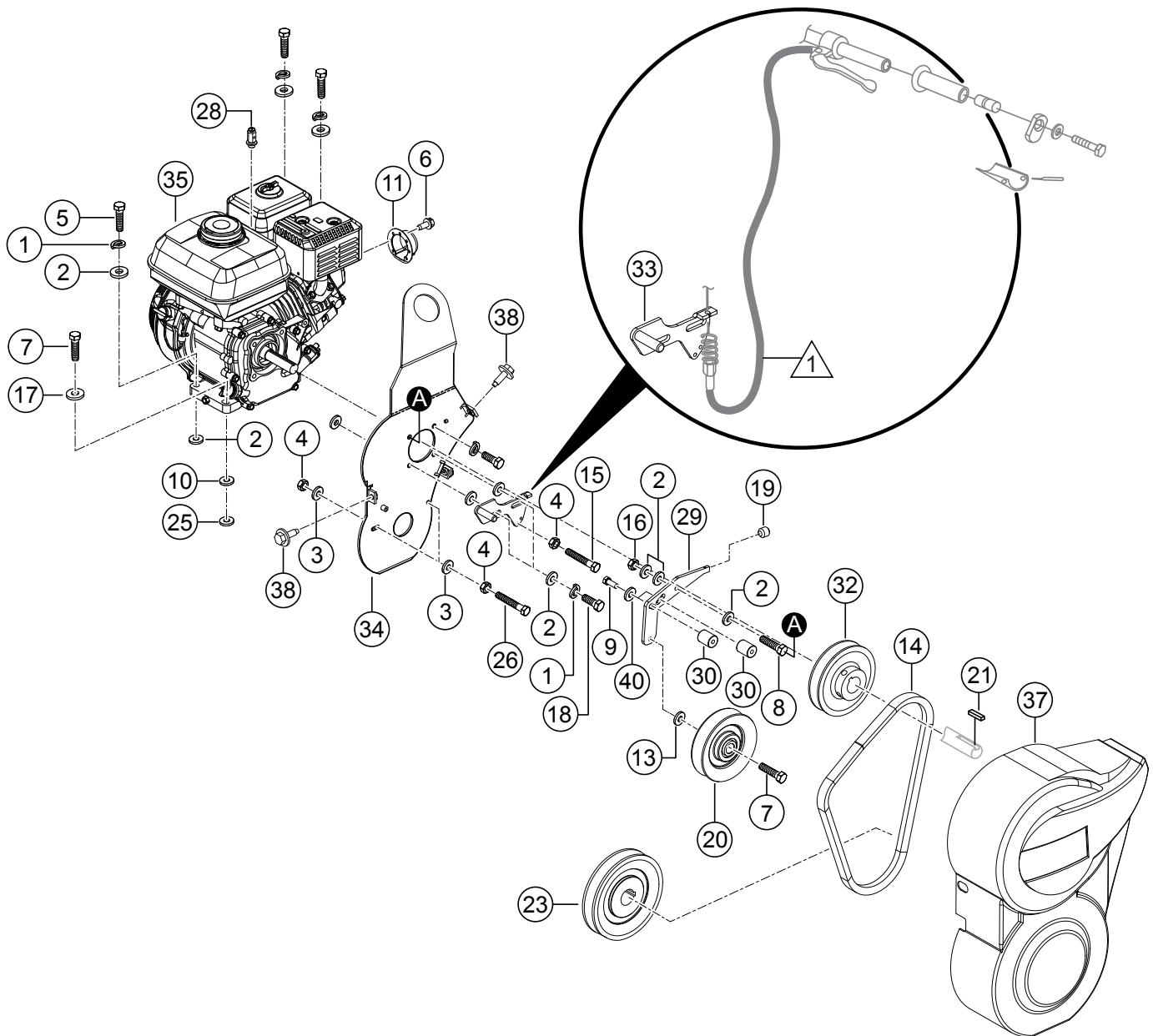

**NOTE:**

 SEE HANDLE ASSY.



## **ENGINE ASSY., 4 HP HONDA (S/N CL0132685 AND ABOVE)**

---

<b>NO.</b>	<b>PART NO.</b>	<b>PART NAME</b>	<b>QTY.</b>	<b>REMARKS</b>
1	0161 C	LOCK WASHER 5/16"	6	
2	0300 B	FLAT WASHER 5/16"	12	
3	0948	FLAT WASHER 1/4"	4	
4	0949	HEX NUT 1/4-20	5	
5	1207	SCREW, HHC 5/16-18 X 1-3/4"	3	
6	1273	SCREW, HHST 3-32 X 3/8"	2	
7	1284	SCREW, HHC 3/8-16 X 1-1/2"	2	
8	1391	SCREW, HHC 5/16-24 X 1-1/2" ZINC	1	
9	1672	SCREW, HHC 3/8-24 X 1"	2	
10	1733	WASHER, 1/2 X 1/32"	1	
11	1834	DEFLECTOR, HONDA EXHAUST	1	
13	1897	SPACER, 0.75" OD X 0.38" ID X 0.188"	1	
14	2343	BELT (A25)	1	
15	4538	SCREW, HHC 1/4-20 X 2-1/2"	1	
16	6014 C	NUT, HEX 5/16-24	1	
17	10136	FLAT WASHER 3/8"	1	
18	10181	SCREW, HHC 5/16-24 X 1-1/4"	3	
19	10450	SCREW, SHS 10-32 X 1/4"	1	
20	10608	PULLEY, IDLER	1	
21	10909	SQUARE KEY 3/16" X 11/16"	1	
23	11043	PULLEY, AK41 X 3/4"	1	
25	13351	WASHER, FLAT USS 3/8" EXT. THK.	1	
26	19380	SCREW, HHC 1/4-20 X 3"	2	
28	20845	SWIVEL, ASM THROTTLE CABLE	1	
29	20977	CLUTCH LEVER	1	
30	20981	SHOE, BELT HAND CLUTCH	2	
32	21675	PULLEY AK-32 X 3/4"	1	
33	21713	CLUTCH BRACKET	1	
34	21752	BRACKET, LIFT BALE/ PULLEY GUARD	1	
35	22900	ENGINE, HONDA GX120 TIER 3 (3.5 HP)	1	
38	30119	SCREW, 1/4-20 X 7/8" IND HEX, DOG PT	3	
40	933242	WASHER, FLAT SAE 3/8" GRD 9 YZ	2	

# GUARD RING ASSY.

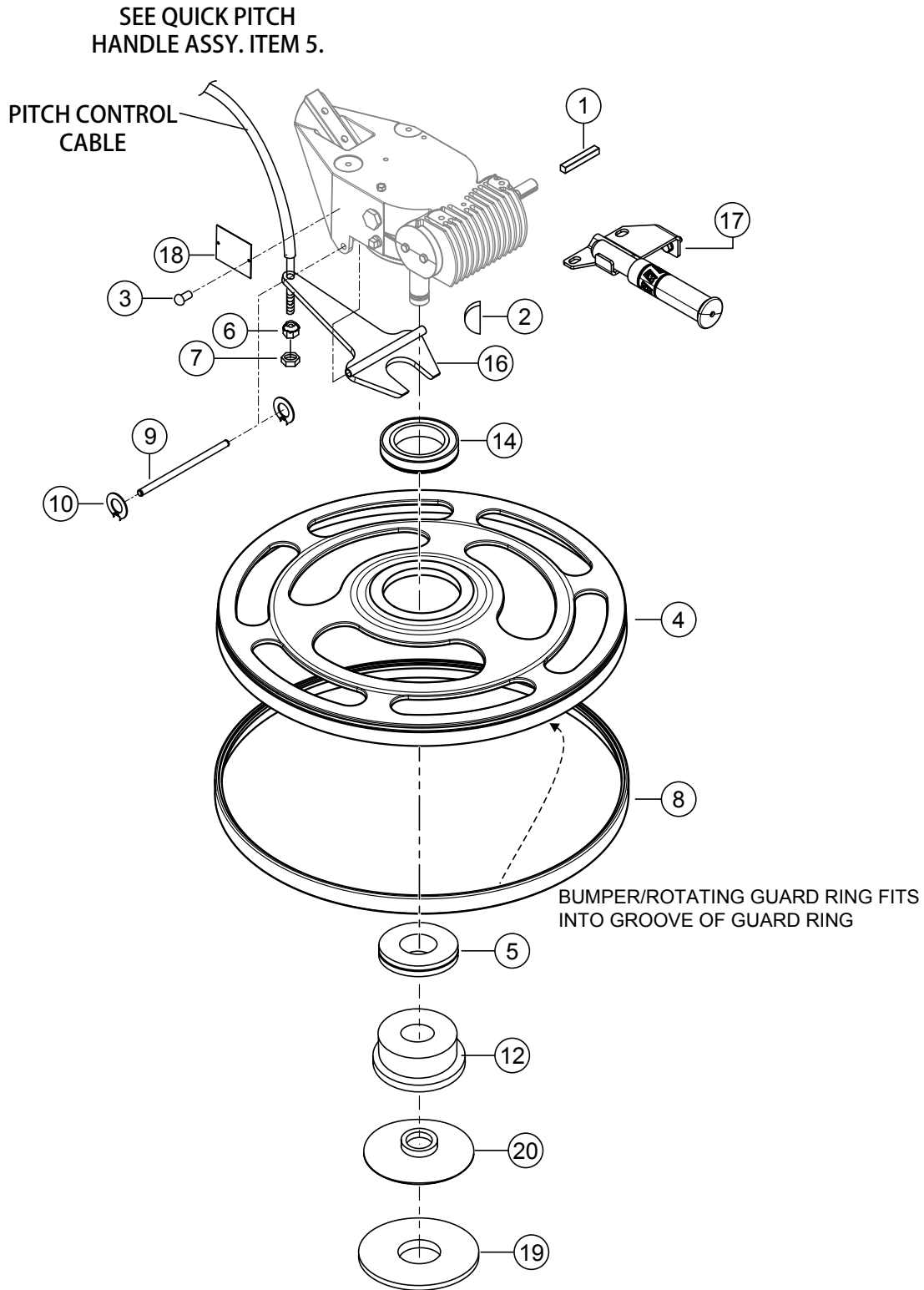

## GUARD RING ASSY.

<u>NO.</u>	<u>PART NO.</u>	<u>PART NAME</u>	<u>QTY.</u>	<u>REMARKS</u>
1	0627	KEY, 3/16" X 1-1/4"	1	
2	1139	KEY, WOODRUFF 1/4 X 1-1/4" (#21) HRDND	1	
3	4014	SCREW, 2-3/16" P-K TYPE U DRIVE	2	
4	21433	RING, ROTATING GUARD	1	
5	10607	BEARING, THRUST 6207, SEALED BOTH SIDES	1	
6	10698	NUT, ADJUSTING 5/16-18	1	
7	1116	NUT, BRASS JAM 5/16-18	1	
8	24304	BUMBER	1	
9	20801	PIN, YOKE	1	
10	20802	RING, SNAP, TRUARC 5100-37 or EQUAL JA	2	
11	21433	RING, ROTATING GUARD	1	
12	21434	SLEEVE, PITCH	1	
14	21441	BEARING, 2.9375" I.D. 4.527" O.D.	1	
15	24304	BUMPER, 24" ROTATING GUARD RING	1	
16	21477	YOKE W/A, CA4	1	
17	22673	LIFT BRACKET ASM, CA4	1	
18		SERIAL PLATE .....	1	.....CONTACT MQ PARTS DEPT.
19	10639	WEAR PLATE	1	
20	10567	THRUST COLLAR	1	

# BLADES & PAN ASSY.

---

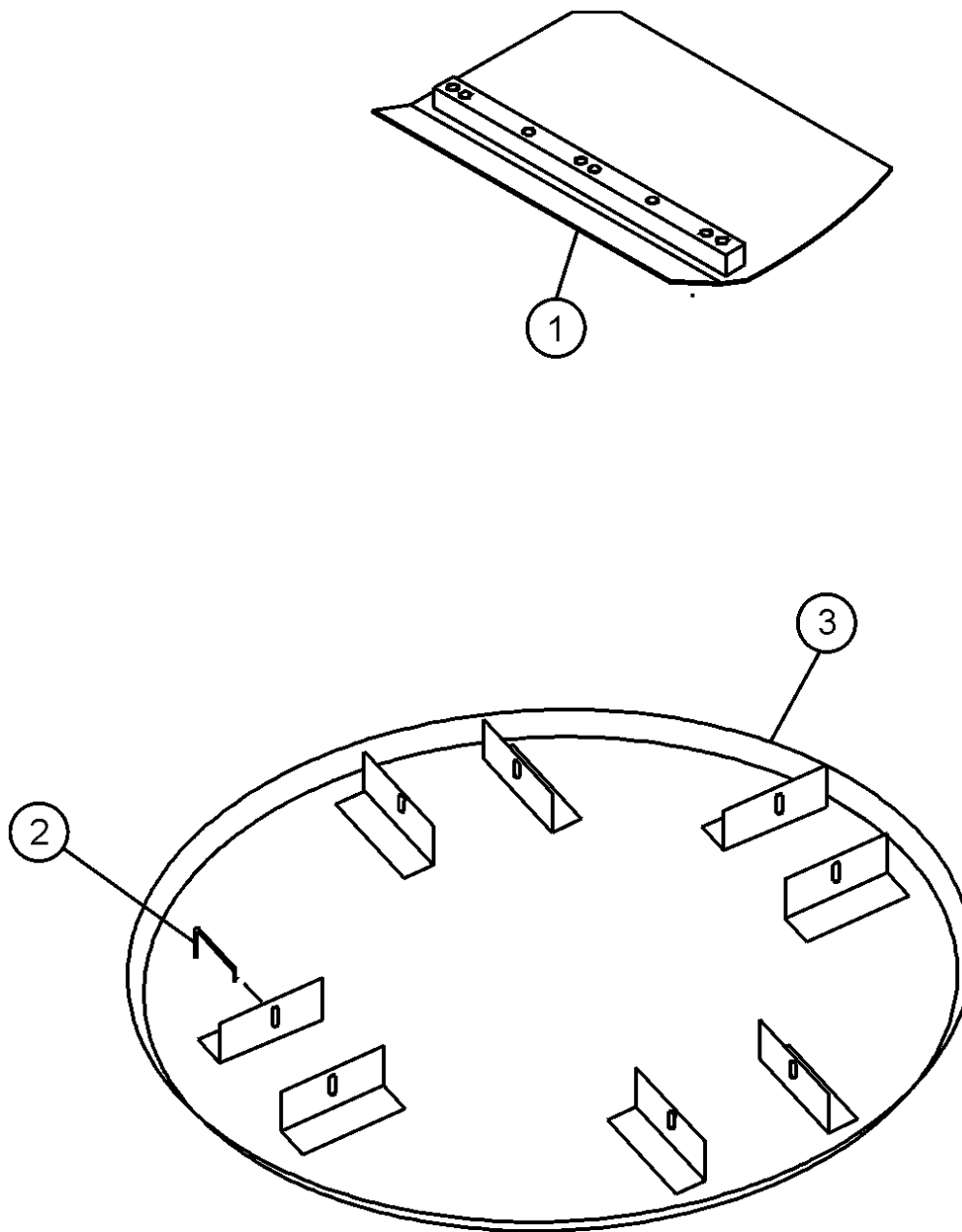

## BLADES & PAN ASSY.

---

<u>NO.</u>	<u>PART NO.</u>	<u>PART NAME</u>	<u>QTY.</u>	<u>REMARKS</u>
1		COMBO FLOAT & FINISH BLADE .....	4.....	CONTACT UNIT SALES DEPT./ .....ACCESSORY ITEM
2		FLOAT DISC LATCH PIN.....	4.....	CONTACT UNIT SALES DEPT./ .....ACCESSORY ITEM
3		FLOAT DISC .....	1.....	CONTACT UNIT SALES DEPT./ .....ACCESSORY ITEM

# HONDA GX120K1QX2/UT1QX2 ENGINE — AIR CLEANER (DUAL) ASSY.

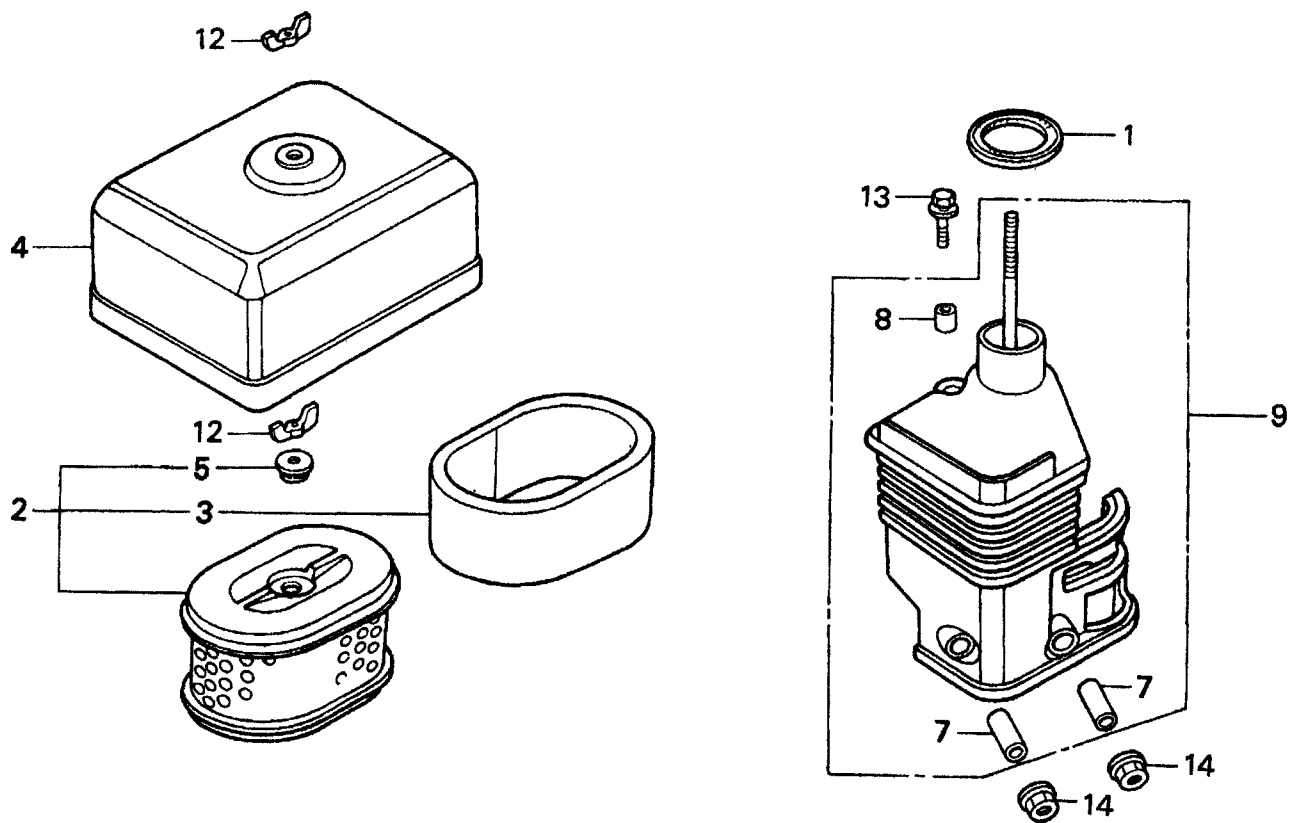

# HONDA GX120K1QX2/UT1QX2 ENGINE — AIR CLEANER (DUAL) ASSY.

AIRCLEANER (DUAL) ASSY.

<u>NO.</u>	<u>PART NO.</u>	<u>PART NAME</u>	<u>QTY.</u>	<u>REMARKS</u>
1	16271ZE1000	GASKET, ELBOW	1	
2♦	17210ZE0505	ELEMENT, AIR CLEANER (DUAL).....	1	INCLUDES ITEMS W/\$
2◇	17210ZE0822	ELEMENT, AIR CLEANER (DUAL).....	1	INCLUDES ITEMS W/\$
3♦\$	17218ZE0505	FILTER, OUTER	1	
3◇\$	17218ZE0820	FILTER, OUTER	1	
4	17230ZE0820	COVER, AIR CLEANER (DUAL)	1	
5\$	17232891000	GROMMET, AIR CLEANER	1	
7#	17238ZE0010	COLLAR, AIR CLEANER	2	
8#	17239ZE1000	COLLAR B, AIR CLEANER	1	
9	17410ZE0030	ELBOW, AIR CLEANER .....	1	INCLUDES ITEMS W/#
12	90325044000	WINGNUT, TOOL BOX SETTING	2	
13	957010602000	BOLT, FLANGE 6X20	1	
14	9405006000	NUT, FLANGE 6MM	2	

## NOTICE

♦ GX120K1QX2: AUGUST 2008 AND BELOW

◇ GX120UT1QX2: SEPTEMBER 2008 AND ABOVE

# HONDA GX120K1QX2/UT1QX2 ENGINE — CAMSHAFT ASSY.

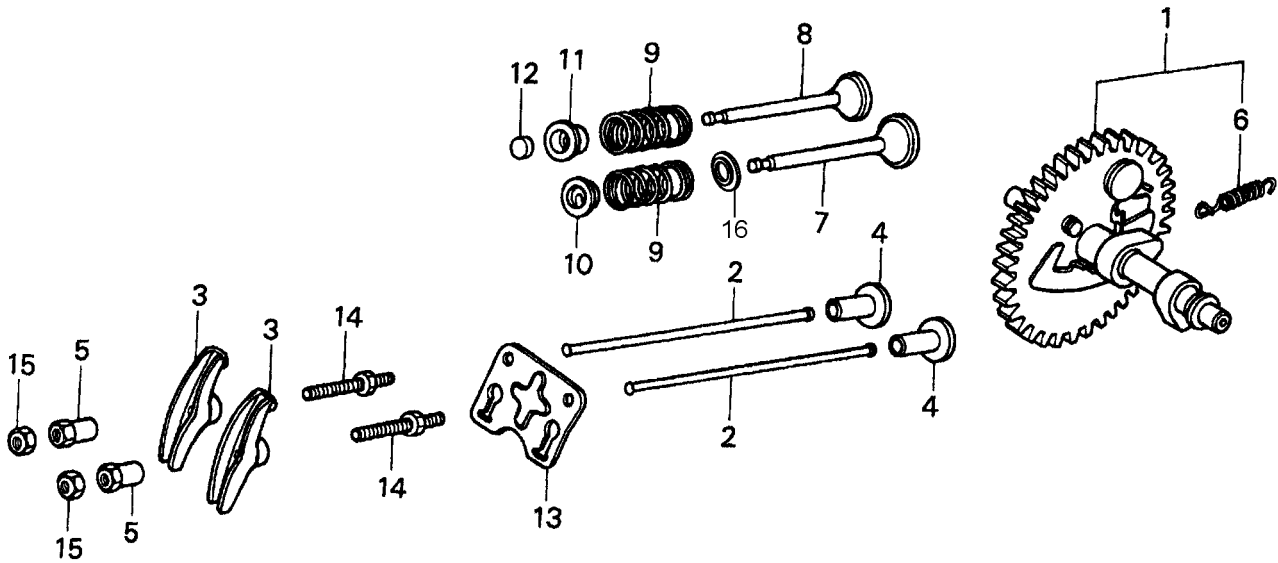



# HONDA GX120K1QX2/UT1QX2 ENGINE — CAMSHAFT ASSY.

## CAMSHAFT ASSY.

<u>NO.</u>	<u>PART NO.</u>	<u>PART NAME</u>	<u>QTY.</u>	<u>REMARKS</u>
1	14100ZE0812	CAMSHAFT ASSEMBLY .....	1.....	INCLUDES ITEMS W/\$
2	14410ZE0010	ROD, PUSH	2	
3	14431ZE1000	ARM, VALVE ROCKER	2	
4	14441ZE1010	LIFTER, VALVE	2	
5	14451ZE1013	PIVOT, ROCKER ARM	2	
6\$	14568ZE1000	SPRING, WEIGHT RETURN	1	
7	14711ZF0010	VALVE, INTAKE	1	
8	14721ZF0000	VALVE, EXHAUST	1	
9	14751ZF1000	SPRING, VALVE	2	
10	14771ZE1000	RETAINER, IN. VALVE SPRING	1	
11	14773ZE1000	RETAINER, EX. VALVE SPRING	1	
12	14781ZE1000	ROTATOR, VALVE	1	
13	14791ZE0010	PLATE, PUSH ROD GUIDE	1	
14	90012ZE0010	BOLT, PIVOT 8MM	2	
15	90206ZE1000	NUT, PIVOT ADJ.	2	
16◇	12209ZH8003	SEAL, VALE STEM	1	

### NOTICE

◆ GX120K1QX2: AUGUST 2008 AND BELOW

◇ GX120UT1QX2: SEPTEMBER 2008 AND ABOVE

**HONDA GX120K1QX2/UT1QX2 ENGINE — CARBURETOR ASSY.**

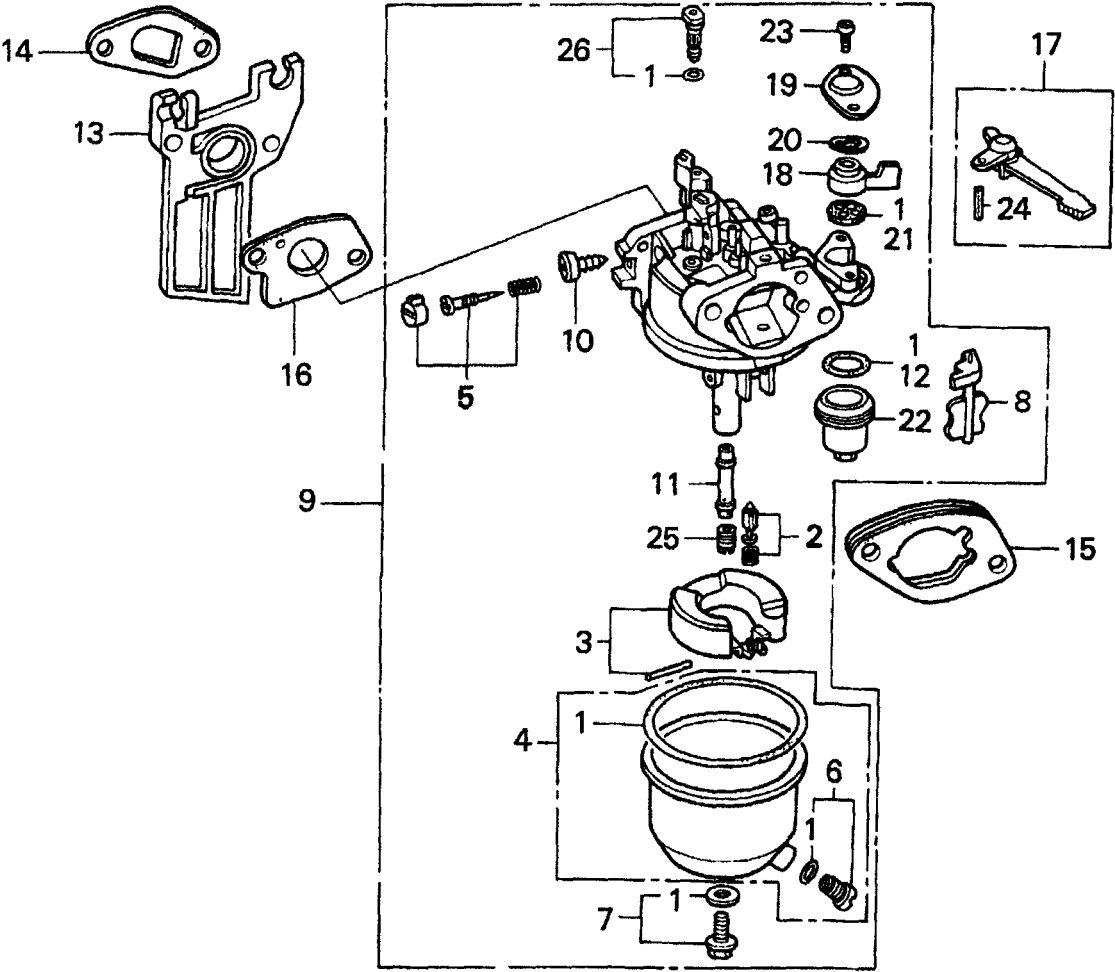

# HONDA GX120K1QX2/UT1QX2 ENGINE — CARBURETOR ASSY.

## CARBURETOR ASSY.

<u>NO.</u>	<u>PART NO.</u>	<u>PART NAME</u>	<u>QTY.</u>	<u>REMARKS</u>
1\$	16010ZE1812	GASKET SET	1	
2\$	16011ZE0005	VALVE SET, FLOAT	1	
3◆	16013ZE0005	FLOAT SET	1	
3◇	16013Z0SB01	FLOAT SET	1	
4◆	16015ZE1811	CHAMBER SET, FLOAT, BE60B A	1	
4◆	16015ZE1831	CHAMBER SET, FLOAT, BE60B B	1	
4◇	16015ZE0831	CHAMBER SET, FLOAT	1	
5\$	16016ZH7W01	SCREW SET, PILOT	1	
6\$	16024ZE1811	SCREW SET, DRAIN	1	
7\$	16028ZE0005	SCREW SET B	1	
8\$	16044ZE0005	CHOKE SET, BE12A B	1	
9◆	16100ZH8W50	CARBURETOR ASSY. (BE65B A).....	1	S/N 2728507 AND BELOW INCLUDES ITEMS W/\$
9◆	16100ZH8W51	CARBURETOR ASSY. (BE65B B).....	1	S/N 3491425 AND ABOVE INCLUDES ITEMS W/\$
9◇	16100Z0S921	CARBURETOR ASSY. (BE60R A).....	1	INCLUDES ITEMS W/\$
10\$	16124ZE0005	SCREW, THROTTLE STOP	1	
11\$	16166ZH7W50	NOZZLE, MAIN BE12A B	1	
12\$	16173001004	PACKING, FUEL STRAINER CUP	1	
13	16211ZE1000	INSULATOR, CARBURETOR	1	
14	16212ZH7800	GASKET, INSULATOR	1	
15	16220ZE1020	SPACER, CARBURETOR	1	
16◆	16221ZH8800	GASKET, CARBURETOR.....	1	S/N 2533057 AND BELOW
16◆	16221ZH8801	GASKET, CARBURETOR.....	1	S/N 2534177 AND ABOVE
16◇	16221ZH8801	GASKET, CARBURETOR	1	
17	16610ZE1000	LEVER, CHOKE (STD).....	1	INCLUDES ITEMS W/#
18\$	16953ZE1812	LEVER, VALVE	1	
19\$	16954ZE1811	PLATE, LEVER SETTING	1	
20\$	16956ZE1811	SPRING, VALVE LEVER	1	
21\$	16957ZE1812	GASKET, VALVE	1	
22\$	16967ZE0811	CUP, FUEL STRAINER	1	
23◆\$	93500030080G	SCREW, PAN (3 X 6)	2	
23◇\$	93500030061H	SCREW, PAN (3 X 6)	2	
24#	9430520122	PIN, SPRING (2 X 12)	1	
25	99101ZH80550	JET, MAIN (#55) OPTIONAL	1	
25	99101ZH80580	JET, MAIN (#58) OPTIONAL	1	
25\$	99101ZH80600	JET, MAIN (#60)	1	
26\$	99204ZE00350	JET, SET, PILOT (#35)	1	

### NOTICE

◆ GX120K1QX2: AUGUST 2008 AND BELOW

◇ GX120UT1QX2: SEPTEMBER 2008 AND ABOVE

# HONDA GX120K1QX2/UT1QX2 ENGINE — CONTROL ASSY.

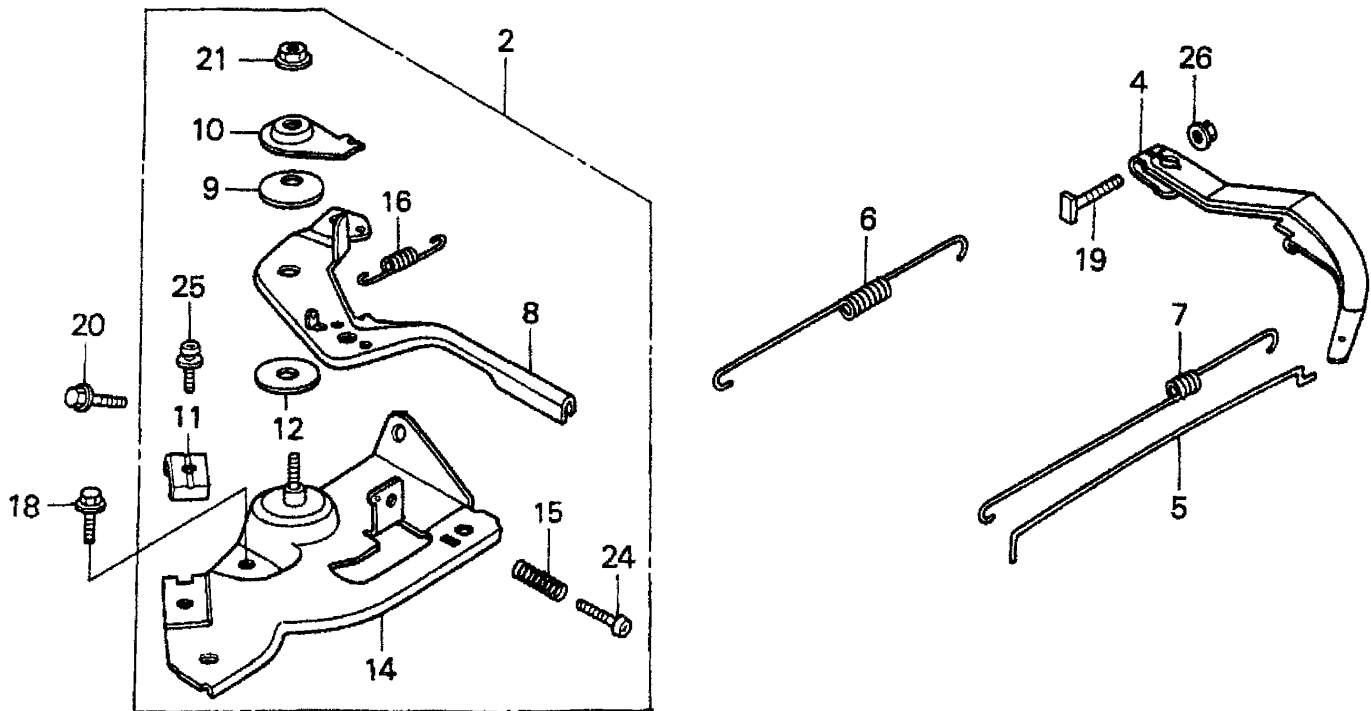

# HONDA GX120K1QX2/UT1QX2 ENGINE — CONTROL ASSY.

## CONTROL ASSY.

<u>NO.</u>	<u>PART NO.</u>	<u>PART NAME</u>	<u>QTY.</u>	<u>REMARKS</u>
2	16500ZH7820	CONTROL ASSEMBLY.....	1.....	INCLUDES ITEMS W/\$
4	16551ZE0010	ARM, GOVERNOR	1	
5	16555ZE0000	ROD, GOVERNOR	1	
6	16561ZE0020	SPRING, GOVERNOR	1	
7	16562ZE0020	SPRING, THROTTLE RETURN	1	
8\$	16571ZH7000	LEVER, CONTROL	1	
9\$	16574ZE1000	SPRING, LEVER	1	
10\$	16575ZH8000	WASHER, CONTROL LEVER	1	
11\$	16576891000	HOLDER, CABLE	1	
12\$	16578ZE1000	SPACER, CONTROL LEVER	1	
14\$	16580ZH7810	BASE, CONTROL	1	
15\$	16584883300	SPRING, CONTROL ADJUSTING	1	
16\$	16592ZE1810	SPRING, CABLE RETURN	1	
18	90013883000	BOLT, FLANGE 6X12 (CT200)	1	
19	90015ZE5010	BOLT, GOVERNOR ARM	1	
20	90022888010	BOLT, FLANGE 6X20 (CT200)	1	
21\$	90114SA0000	NUT, SELF- LOCK 6MM	1	
24\$	93500050250H	SCREW, PAN 5X25	1	
25\$	93500050160A	SCREW-WASHER (5X16)	1	
26	9405006000	NUT, FLANGE 6MM	1	

# HONDA GX120K1QX2/UT1QX2 ENGINE — CRACKCASE COVER ASSY.

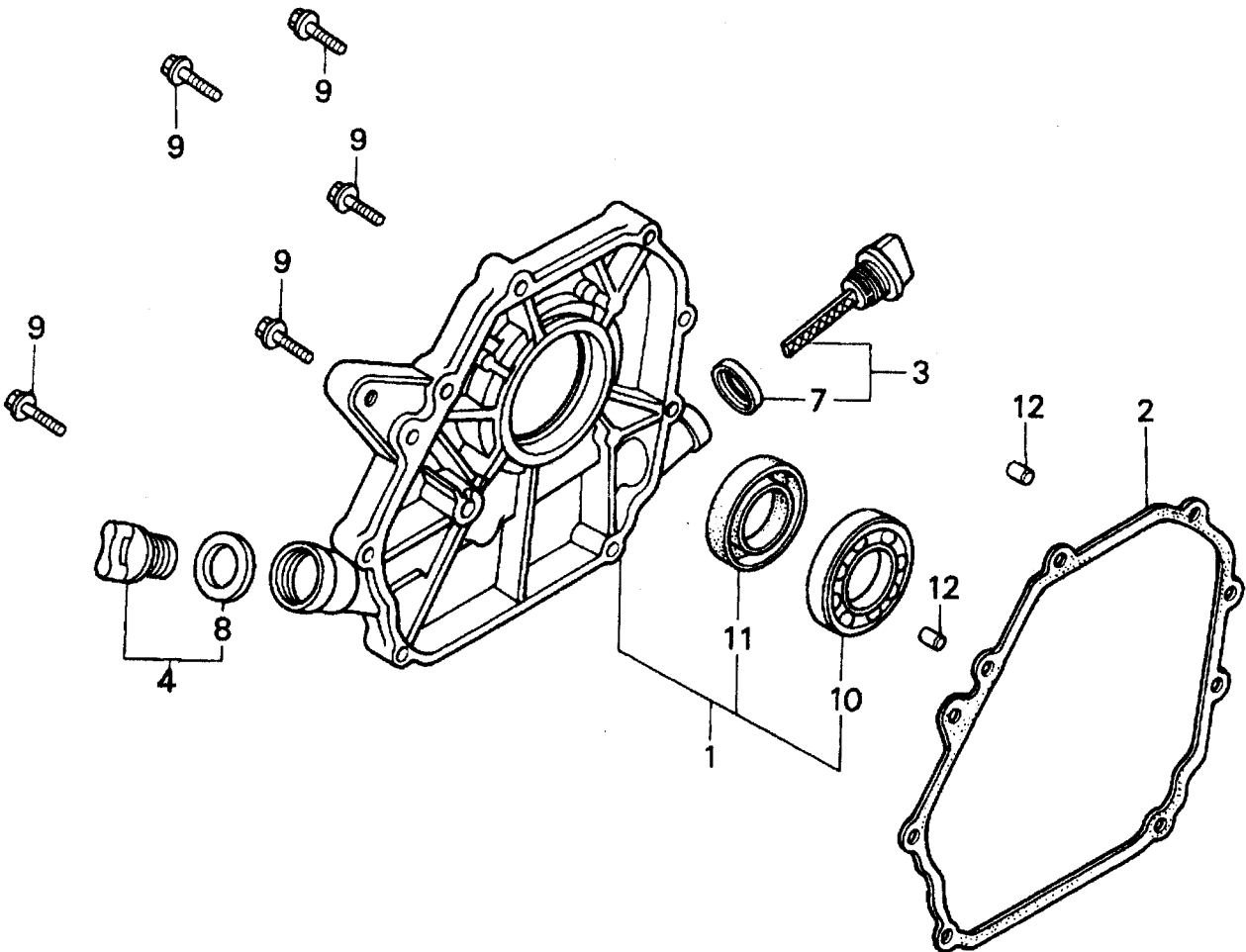

# HONDA GX120K1QX2/UT1QX2 ENGINE — CRACKCASE COVER ASSY.

## CRANKCASE COVER ASSY.

<u>NO.</u>	<u>PART NO.</u>	<u>PART NAME</u>	<u>QTY.</u>	<u>REMARKS</u>
1◆	11300ZE0640	COVER ASSEMBLY, CRANKCASE (U- TYPE) .....	1	INCLUDES ITEMS W/%
1◇	11300ZE0641	COVER ASSEMBLY, CRANKCASE (U- TYPE) .....	1	INCLUDES ITEMS W/%
2	11381ZH7800	GASKET, CASE COVER	1	
3◆	15600ZE1003	CAP ASSEMBLY, OIL FILLER .....	1	INCLUDES ITEMS W/#
3◇	15600Z0T810	CAP ASSEMBLY, OIL FILLER .....	1	INCLUDES ITEMS W/#
4◆	15600ZG4003	CAP ASSEMBLY, OIL FILLER .....	1	INCLUDES ITEMS W/\$
4◇	15600Z0T820	CAP ASSEMBLY, OIL FILLER .....	1	INCLUDES ITEMS W/\$
7◆#	15625ZE1003	GASKET, OIL FILLER CAP	1	
7◇#	15625Z0T800	GASKET, OIL FILLER CAP	1	
8◆\$	15625ZE1003	GASKET, OIL FILLER CAP	1	
8◇\$	15625Z0T800	GASKET, OIL FILLER CAP	1	
9	90015883000	BOLT, FLANGE 6X28	7	
10%	91001878003	BEARING, RADIAL BALL	1	
11◆%	91203ZE0003	OIL SEAL 22X41X6	1	
11◇%	91203ZE0013	OIL SEAL 22X41X6	1	
12	9430108140	PIN A, DOWEL 8X14	2	

### NOTICE

◆ GX120K1QX2: AUGUST 2008 AND BELOW

◇ GX120UT1QX2: SEPTEMBER 2008 AND ABOVE

**HONDA GX120K1QX2/UT1QX2 ENGINE — CRANKSHAFT ASSY.**

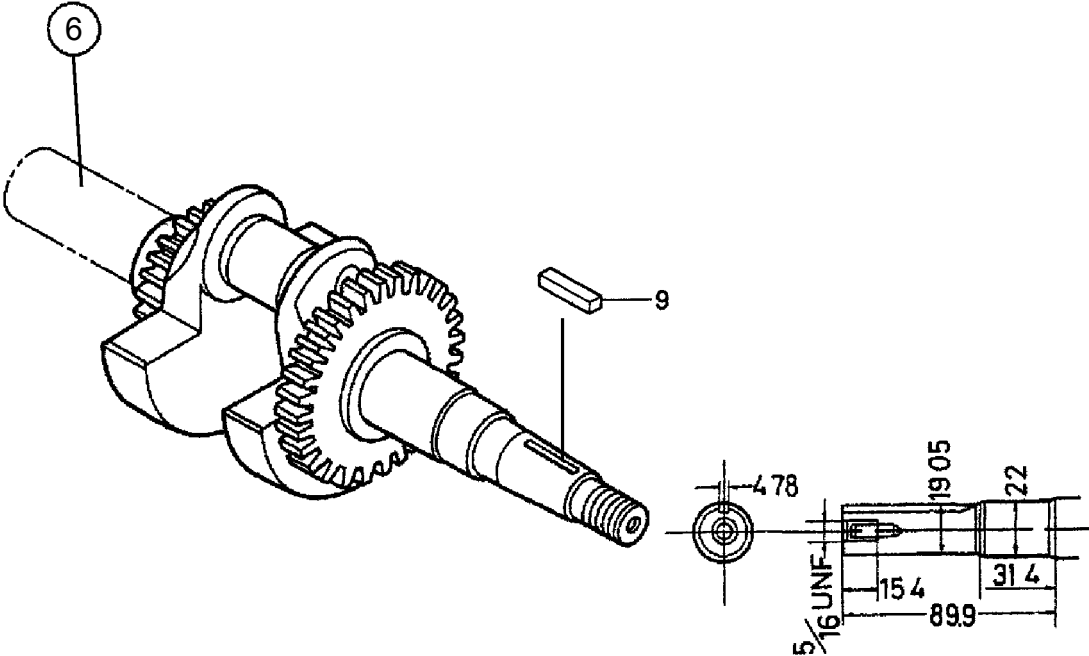



# HONDA GX120K1QX2/UT1QX2 ENGINE — CRANKSHAFT ASSY.

---

CRANKSHAFT ASSY.

<u>NO.</u>	<u>PART NO.</u>	<u>PART NAME</u>	<u>QTY.</u>	<u>REMARKS</u>
6◆	13310ZE0650	CRANKSHAFT, Q-TYPE	1	
6◇	13310Z0S800	CRANKSHAFT, Q-TYPE	1	
9	90745ZE1600	KEY (4.78 X 78 X 38)	1	

## NOTICE

◆ GX120K1QX2: AUGUST 2008 AND BELOW

◇ GX120UT1QX2: SEPTEMBER 2008 AND ABOVE

# HONDA GX120K1QX2/UT1QX2 ENGINE — CYLINDER BARREL ASSY.

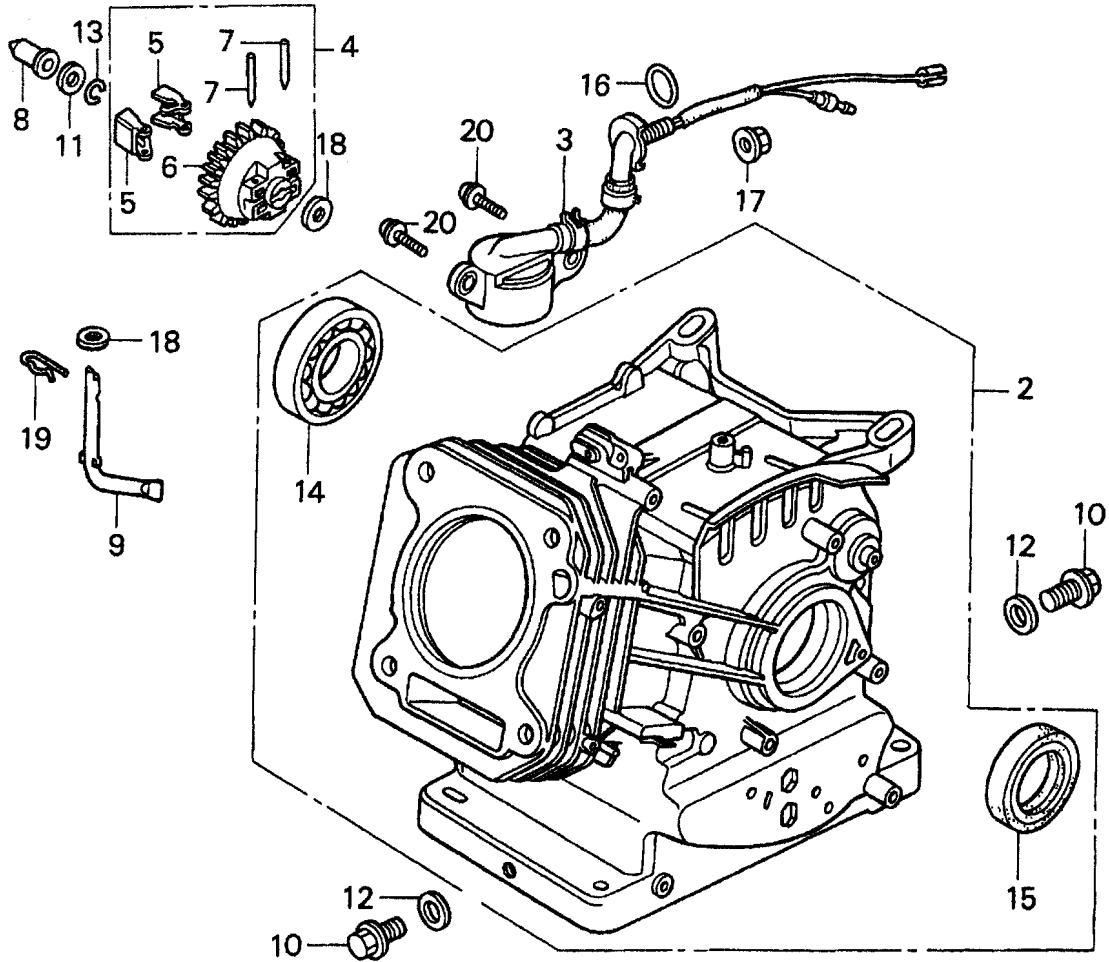

# HONDA GX120K1QX2/UT1QX2 ENGINE — CYLINDER BARREL ASSY.

## CYLINDER BARREL ASSY.

<u>NO.</u>	<u>PART NO.</u>	<u>PART NAME</u>	<u>QTY.</u>	<u>REMARKS</u>
2◆	12000ZH7415	CYLINDER BARREL ASSY. (OIL ALERT).....	1.....	INCLUDES ITEMS W/\$
2◇	12000Z0S416	CYLINDER BARREL ASSY. (OIL ALERT).....	1.....	INCLUDES ITEMS W/\$
3◆	15510ZE1033	SWITCH ASSEMBLY, OIL LEVEL	1	
3◇	15510ZE1033	SWITCH ASSEMBLY, OIL LEVEL .....	1.....	S/N 1111367 AND BELOW
3◇	35480Z0T003	SWITCH ASSEMBLY, OIL LEVEL .....	1.....	S/N 1111367 AND ABOVE
4	16510ZE1000	GOVERNOR ASSEMBLY .....	1.....	INCLUDES ITEMS W/#
5#	16511ZE1000	WEIGHT, GOVERNOR	2	
6#	16512ZE1000	HOLDER, GOVERNOR WEIGHT	1	
7#	16513ZE1000	PIN, GOVERNOR WEIGHT	2	
8	16531ZE1000	SLIDER, GOVERNOR	1	
9	16541ZE1000	SHAFT, GOVERNOR ARM	1	
10	90131ZE1000	BOLT, DRAIN PLUG	2	
11	90451ZE1000	WASHER, THRUST 6MM	1	
12	90601ZE1000	WASHER, DRAIN PLUG 10.2MM	2	
13	90602ZE1000	CLIP, GOVERNOR HOLDER	1	
14\$	91001878003	BEARING, RADIAL BALL 62/22	1	
15◆\$	91202ZE6003	OIL SEAL 22X35X6	1	
15◇\$	91202ZE6013	OIL SEAL 22X35X6	1	
16◆	91353671003	O- RING 13.5X1.5 (ARAI)	1	
16◇	91353671004	O- RING 13.5X1.5 (ARAI)	1	
17	9405010000	NUT, FLANGE 10MM	1	
18	9410106800	WASHER, PLAIN 6MM	2	
19	9425108000	PIN, LOCK 8MM	1	
20	957010601200	BOLT, FLANGE 6X12	2	

### NOTICE

◆ GX120K1QX2: AUGUST 2008 AND BELOW

◇ GX120UT1QX2: SEPTEMBER 2008 AND ABOVE

**HONDA GX120K1QX2/UT1QX2 ENGINE — CYLINDER HEAD ASSY.**

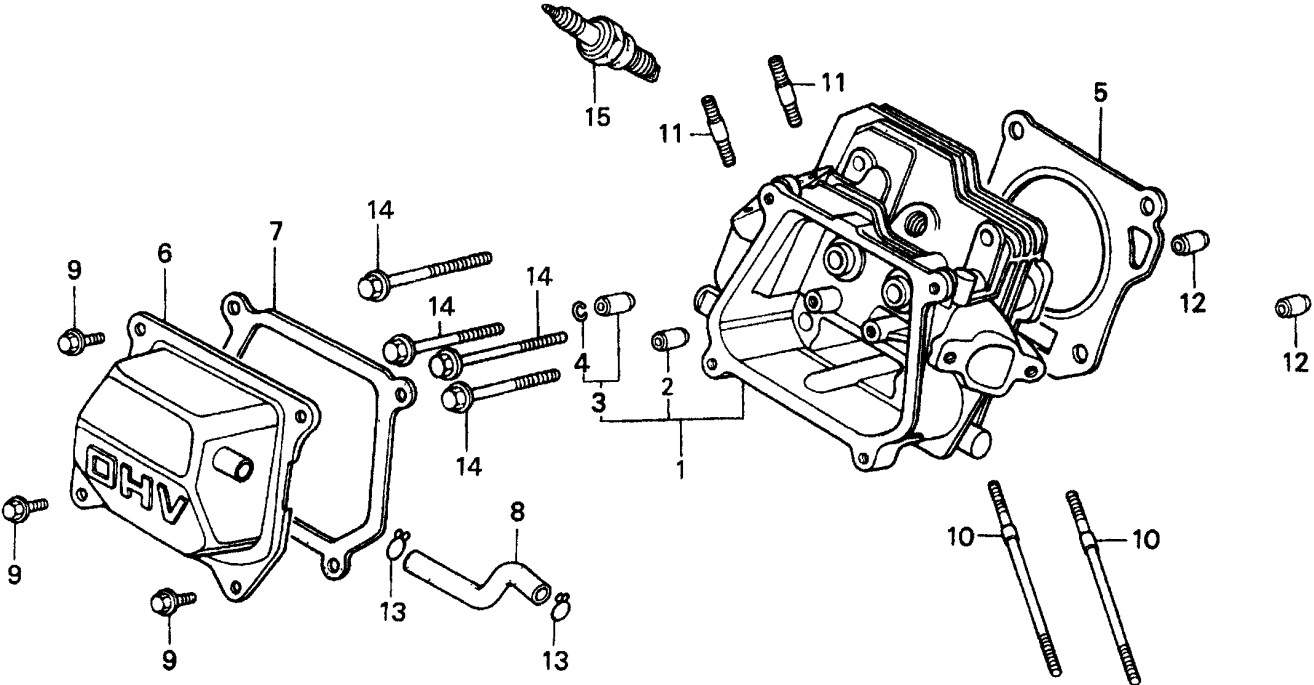

# HONDA GX120K1QX2/UT1QX2 ENGINE — CYLINDER HEAD ASSY.

## CYLINDER HEAD ASSY.

<u>NO.</u>	<u>PART NO.</u>	<u>PART NAME</u>	<u>QTY.</u>	<u>REMARKS</u>
1	12210ZH7000	CYLINDER HEAD.....	1.....	INCLUDES ITEMS W/\$
2\$	12204ZE1306	GUIDE, VALVE (OS) OPTIONAL	1	
3\$	12205ZE1315	GUIDE, EX. VALVE (OS) OPTIONAL .....	1.....	INCLUDES ITEMS W/#
4\$#	12216ZE5300	CLIP, VALVE GUIDE	1	
5	12251ZH7800	GASKET, CYLINDER HEAD	1	
6◆	12310ZE1000	COVER, HEAD .....	1.....	S/N 2533057 AND BELOW
6◆	12310ZE1010	COVER, HEAD .....	1.....	S/N 2533058 TO 3909674
6◆	12310ZE1010	COVER, HEAD .....	1.....	S/N 3909675 AND ABOVE
6◇	12310ZE1020	COVER, HEAD	1	
7	12391ZE1000	GASKET, CYLINDER HEAD COVER	1	
8	15721ZH8000	TUBE, BREATHER	1	
9	90013883000	BOLT, FLANGE 6X12 (CT200)	4	
10	90043ZE1020	BOLT, STUD 6X109	2	
11	90047ZE1000	BOLT, STUD 8X32	2	
12	9430110160	PIN, A, DOWEL 10X16	2	
14	957230805500	BOLT, FLANGE 8X55	4	
15◆	9807955855	SPARK PLUG W16EPR- U (DENSO), OPT.	1	
15◆	9807956846	SPARK PLUG BPR6ES, (NGK)	1	
15◇	9807955876	SPARK PLUG BPR5ES, (NGK)	1	
15◇	9807956876	SPARK PLUG BPR6ES, (NGK)	1	

### NOTICE

◆ GX120K1QX2: AUGUST 2008 AND BELOW

◇ GX120UT1QX2: SEPTEMBER 2008 AND ABOVE

# HONDA GX120K1QX2/UT1QX2 ENGINE — FAN COVER ASSY.

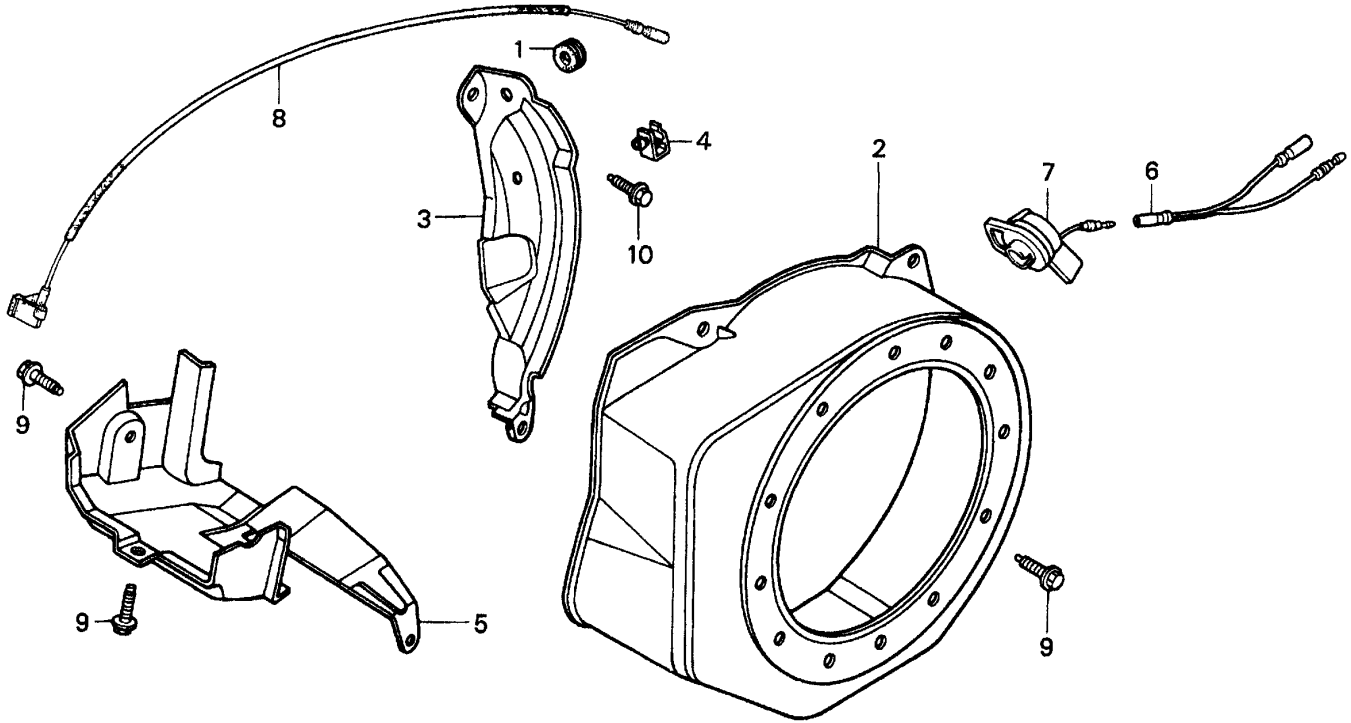

# HONDA GX120K1QX2/UT1QX2 ENGINE — FAN COVER ASSY.

FAN COVER ASSY.

<u>NO.</u>	<u>PART NO.</u>	<u>PART NAME</u>	<u>QTY.</u>	<u>REMARKS</u>
1	11347371300	GROMMET, ADJUSTING COVER	1	
2◆	19610ZE0000ZE	COVER, FAN *NH1* BLACK	1	
2◇	19610ZE0000ZS	COVER, FAN *R280* RED	1	
3	19612ZH7810	PLATE, SIDE (OIL ALERT)	1	
4	90601ZH7013	CLIP, HARNESS	1	
5	19630ZH7000	SHROUD	1	
6	32197ZH8003	SUB- HARNESS	1	
7◆	36100ZH7003	SWITCH ASSEMBLY, ENGINE STOP	1	
7◇	36120Z0T851	SWITCH ASSEMBLY, ENGINE STOP	1	
8	36101ZE1010	WIRE, STOP SWITCH 370MM	1	
9	90013883000	BOLT, FLANGE 6X12 (CT200)	6	
10	90022888010	BOLT, FLANGE 6X12 (CT200)	1	
11◆	34150ZH7003	ALERT UNIT, OIL	1	
11◇	34150ZH7003	ALERT UNIT, OIL.....	1.....	S/N 1170368 AND BELOW
11◇	34150ZH7013	ALERT UNIT, OIL.....	1.....	S/N 1170369 AND ABOVE
13	957010600800	BOLT, FLANGE 6X8	1	

## NOTICE

- ◆ GX120K1QX2: AUGUST 2008 AND BELOW
- ◇ GX120UT1QX2: SEPTEMBER 2008 AND ABOVE

# HONDA GX120K1QX2/UT1QX2 ENGINE — FLYWHEEL ASSY.

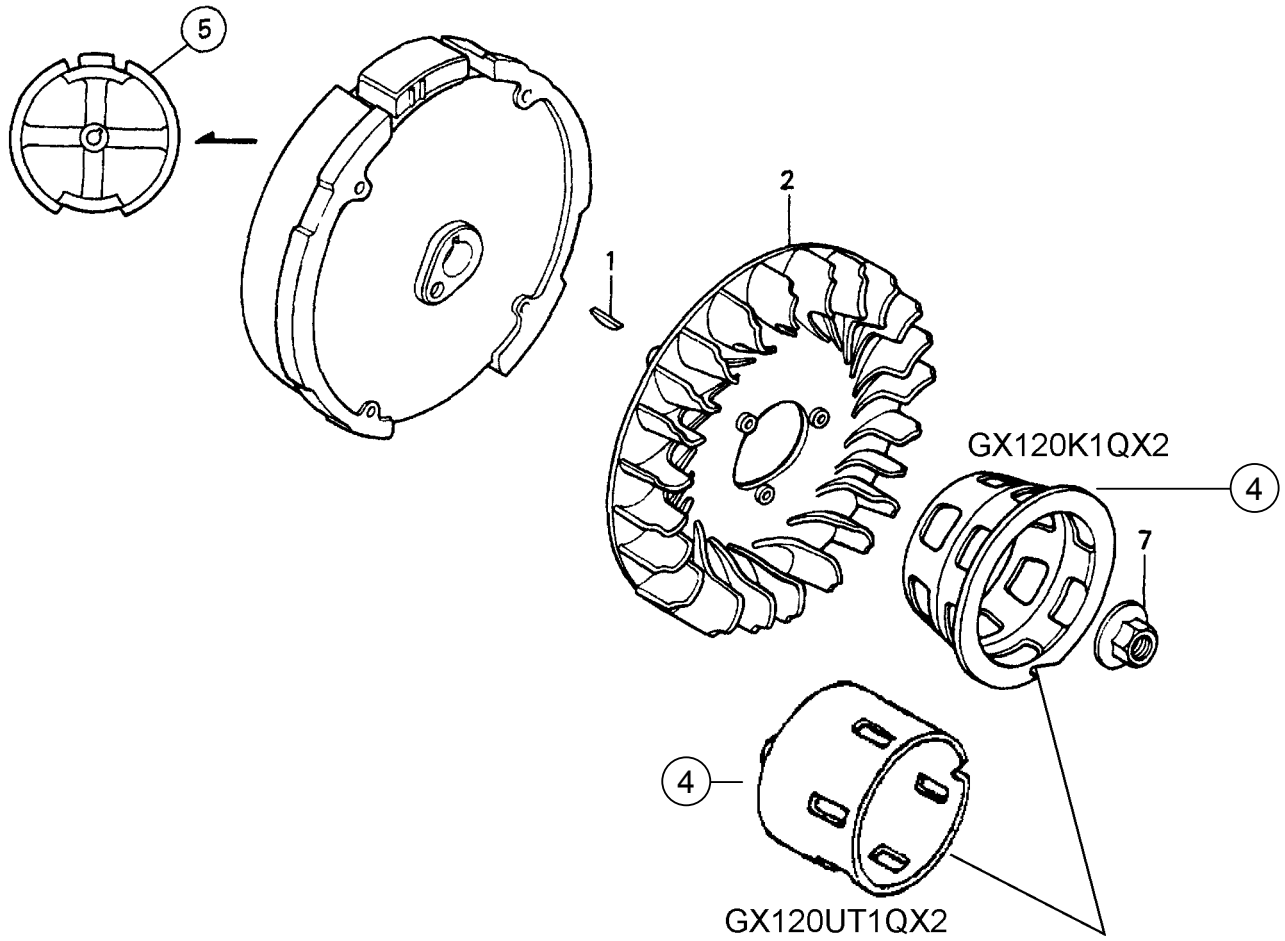



# HONDA GX120K1QX2/UT1QX2 ENGINE — FLYWHEEL ASSY.

FLYWHEEL ASSY.

<u>NO.</u>	<u>PART NO.</u>	<u>PART NAME</u>	<u>QTY.</u>	<u>REMARKS</u>
1	13331357000	KEY, SPECIAL WOODRUFF 25X18	1	
2	19511ZE0000	FAN, COOLING	1	
4♦	28451ZH8003	PULLEY, STARTER .....	1	S/N 391740 AND BELOW
4♦	28451ZH7003	PULLEY, STARTER .....	1	S/N 391741 AND ABOVE
4◇	28451ZH7801	PULLEY, STARTER	1	
5♦	31100ZE0010	FLYWHEEL	1	
5◇	31100ZE0010	FLYWHEEL .....	1	S/N 1120058 AND BELOW
5◇	1120059	FLYWHEEL .....	1	S/N 1120058 AND ABOVE
7♦	90201878003	NUT, SPECIAL 14MM	1	
7◇	90201Z0T800	NUT, SPECIAL 14MM	1	

**NOTICE**

- ♦ GX120K1QX2: AUGUST 2008 AND BELOW
- ◇ GX120UT1QX2: SEPTEMBER 2008 AND ABOVE

# HONDA GX120K1QX2/UT1QX2 ENGINE — FUEL TANK ASSY.

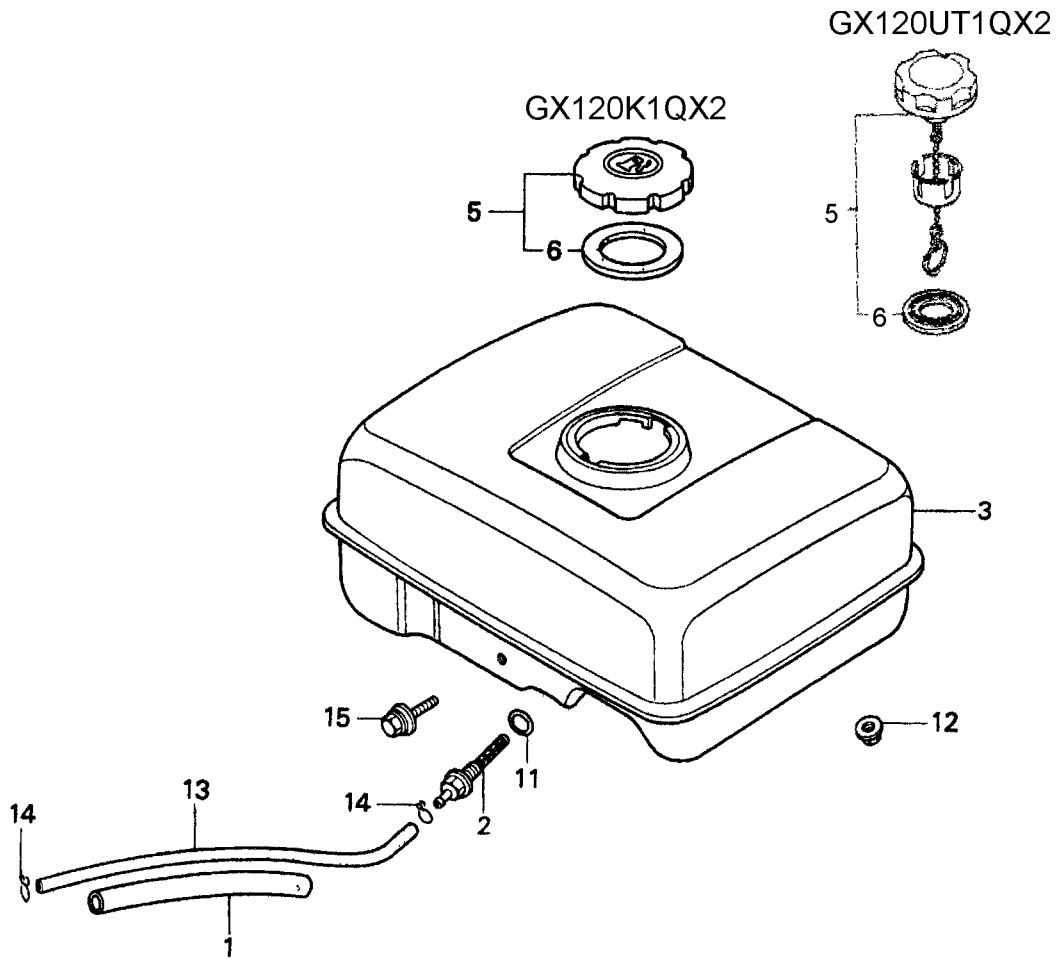

# HONDA GX120K1QX2/UT1QX2 ENGINE — FUEL TANK ASSY.

## FUEL TANK ASSY.

<u>NO.</u>	<u>PART NO.</u>	<u>PART NAME</u>	<u>QTY.</u>	<u>REMARKS</u>
1	16854ZH8000	RUBBER, SUPPORTER 107MM	1	
2	16955ZE1000	JOINT, FUEL TANK	1	
3◆	17510ZE0020ZD	TANK, FUEL *NH1* (BLACK)	1	
3◇	17510Z0S000ZB	TANK, FUEL *NH31* (BLACK) .....	1	S/N 1219127 AND BELOW
3◇	1219128	TANK, FUEL *NH31* (BLACK) .....	1	S/N 1219127 AND ABOVE
5◆	17620ZH7023	CAP, FUEL FILLER.....	1	INCLUDES ITEMS W/ \$
5◇	17620Z0T813	CAP, FUEL FILLER (CHROME PLATED).....	1	S/N 1120058 AND BELOW
		.....		INCLUDES ITEMS W/ \$
5◇	17620Z4H000	CAP, FUEL FILLER.....	1	S/N 1120059 TO 1188057
		.....		INCLUDES ITEMS W/ \$
5◇	17620Z4H010	CAP, FUEL FILLER.....	1	S/N 1188058 TO 1206680
		.....		INCLUDES ITEMS W/ \$
5◇	17620Z4H020	CAP, FUEL FILLER.....	1	S/N 1206681 AND ABOVE
		.....		INCLUDES ITEMS W/ \$
6◆\$	17631ZH7003	GASKET, FUEL FILLER CAP	1	
6◇\$	17631Z4H800	GASKET, FUEL FILLER CAP .....	1	S/N 1188057 AND BELOW
6◇\$	17631Z4H800	GASKET, FUEL FILLER CAP .....	1	S/N 1188058 TO 1206680
6◇\$	17631Z0T801	GASKET, FUEL FILLER CAP .....	1	S/N 1206681 AND ABOVE
11\$	91353671003	O- RING 13.5X1.5 (ARAI)	1	
11\$	91353671004	O- RING 13.5X1.5 (ARAI)	1	
12	9405006000	NUT, FLANGE 6MM	2	
13	950014500360M	BULK HOSE, FUEL (4.5X3000) (4.5X140)	1	
14◆	9500202080	CLIP, TUBE (B8)	2	
14◇	9500202080	CLIP, TUBE (B8) .....	2	S/N 1038089 AND BELOW
14◇	950024080008	CLAMP, TUBE (D8).....	2	S/N 1038090 AND ABOVE
15	90004ZH7003	BOLT, FLANGE 6X29	1	

### NOTICE

◆ GX120K1QX2: AUGUST 2008 AND BELOW

◇ GX120UT1QX2: SEPTEMBER 2008 AND ABOVE

# HONDA GX120K1QX2/UT1QX2 ENGINE — IGNITION COIL ASSY.

---

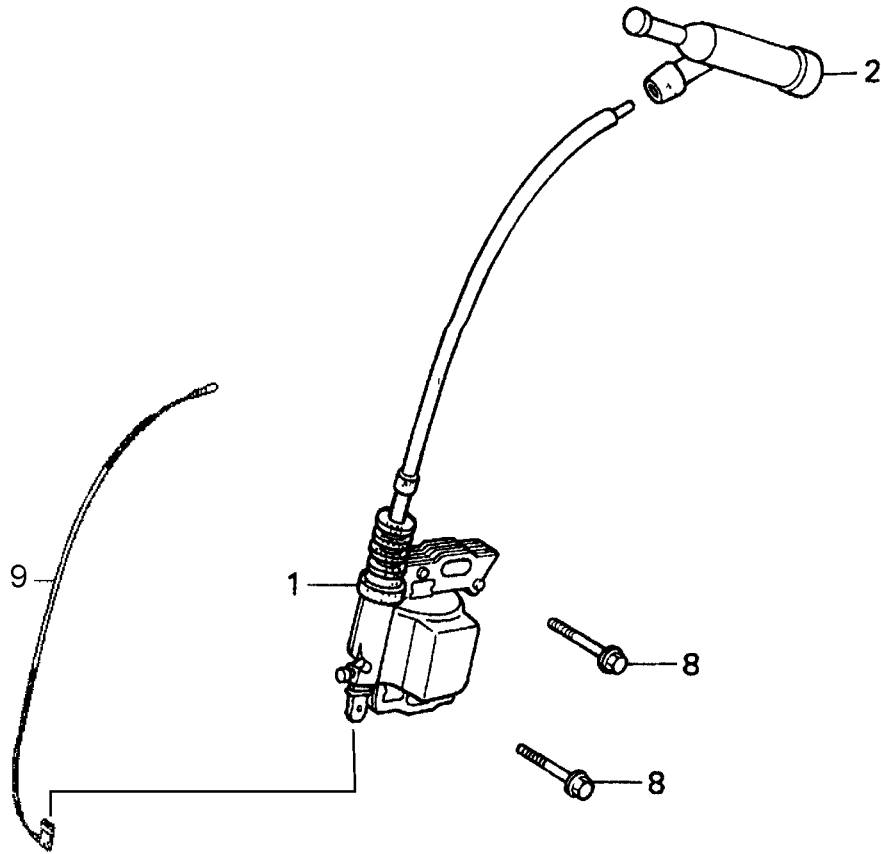

# HONDA GX120K1QX2/UT1QX2 ENGINE — IGNITION COIL ASSY.

## IGNITION COIL ASSY.

<u>NO.</u>	<u>PART NO.</u>	<u>PART NAME</u>	<u>QTY.</u>	<u>REMARKS</u>
1◆	30500ZE1033	COIL ASSEMBLY, IGNITION	1	
1◇	30500Z0T801	COIL ASSEMBLY, IGNITION .....	1.....	S/N 1098652 AND BELOW
1◇	30500Z0T802	COIL ASSEMBLY, IGNITION .....	1.....	S/N 1098653 AND ABOVE
2◆	30700ZE1013	CAP ASSEMBLY, NOISE SUPPRESSOR	1	
2◇	30700Z0T811	CAP ASSEMBLY, NOISE SUPPRESSOR	1	
8	90121952000	BOLT, FLANGE 6X25	2	
9	36101ZE0101	CORD STOP SWITCH (370 MM)	1	

### NOTICE

◆ GX120K1QX2: AUGUST 2008 AND BELOW

◇ GX120UT1QX2: SEPTEMBER 2008 AND ABOVE

# HONDA GX120K1QX2/UT1QX2 ENGINE — MUFFLER ASSY.

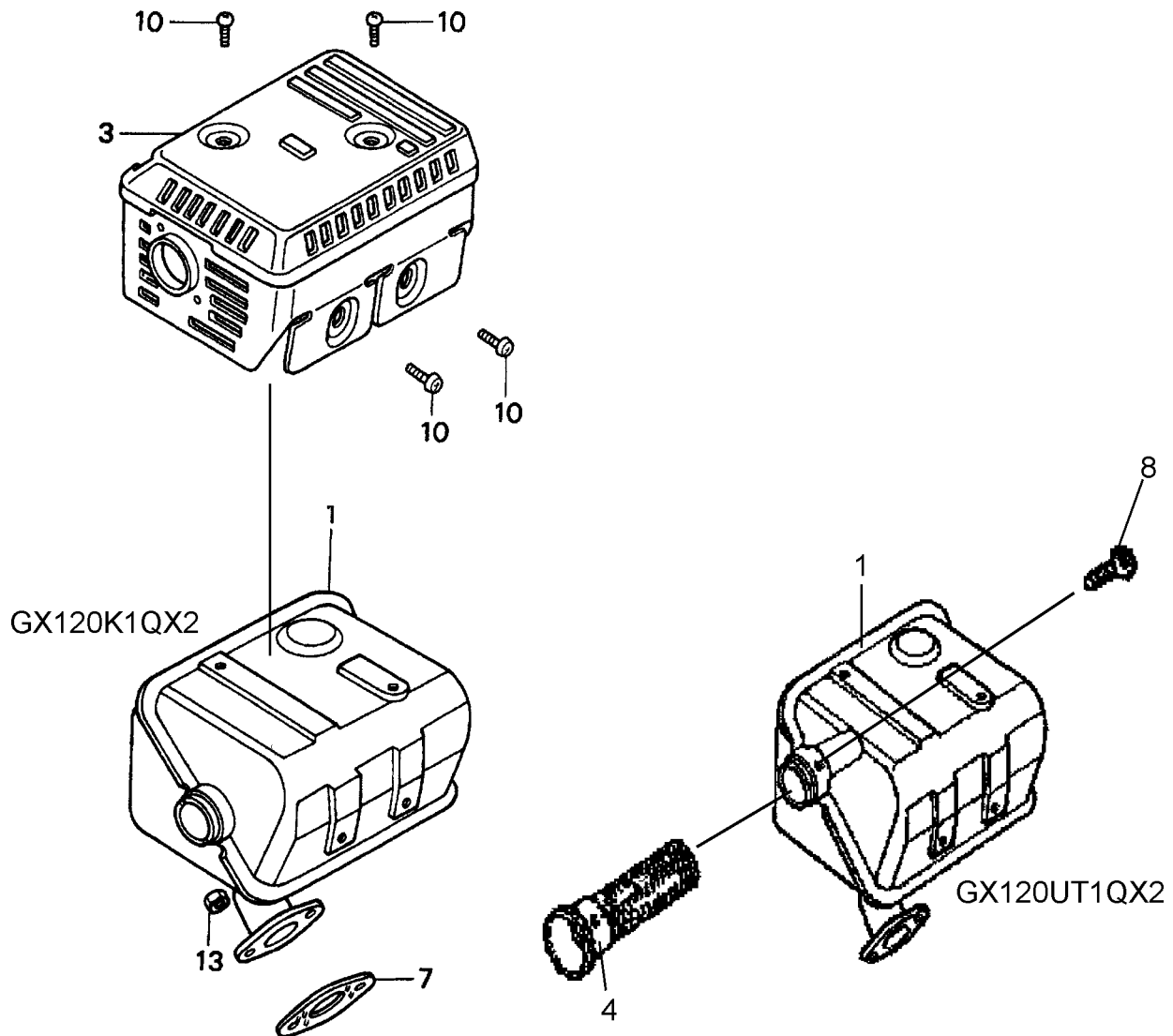

# HONDA GX120K1QX2/UT1QX2 ENGINE — MUFFLER ASSY.

MUFFLER ASSY.

<u>NO.</u>	<u>PART NO.</u>	<u>PART NAME</u>	<u>QTY.</u>	<u>REMARKS</u>
1◆	18310ZF1000	MUFFLER	1	
1◇	18310ZF8810	MUFFLER	1	
3	18320ZF1H01	PROTECTOR, MUFFLER	1	
4◇	18355ZE1000	ARRESTOR, SPARK	1	
7◆	18381ZH8800	GASKET, MUFFLER	1	
7◇	18381ZH8800	GASKET, MUFFLER.....	1.....	S/N 1060773 AND BELOW
7◇	18381Z0T801	GASKET, MUFFLER.....	1.....	S/N 1060774 AND ABOVE
8◇	90055ZE1000	SCREW, TAPPING 5X8	1	
10	90050ZE1000	SCREW, TAPPING 5X8	4	
13	94001080000S	NUT, HEX. 8MM	2	

**NOTICE**

- ◆ GX120K1QX2: AUGUST 2008 AND BELOW
- ◇ GX120UT1QX2: SEPTEMBER 2008 AND ABOVE

# HONDA GX120K1QX2/UT1QX2 ENGINE — PISTON ASSY.

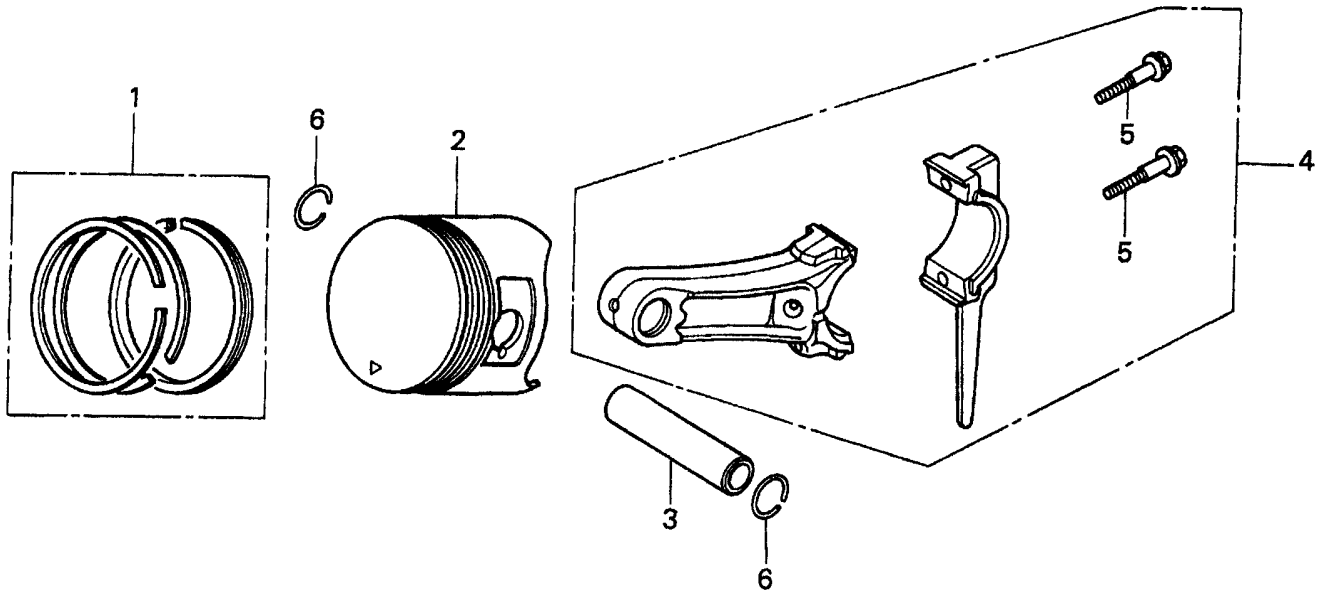



# HONDA GX120K1QX2/UT1QX2 ENGINE — PISTON ASSY.

PISTON ASSY.

<u>NO.</u>	<u>PART NO.</u>	<u>PART NAME</u>	<u>QTY.</u>	<u>REMARKS</u>
1◆	13010ZK7V01	RING SET, PISTON (STANDARD)	1	
1◇	13010Z4F004	RING SET, PISTON (STANDARD)	1	
1◆	13011ZK7V01	RING SET, PISTON (OS 0.25), OPTIONAL	1	
1◇	13011Z4F004	RING SET, PISTON (OS 0.25), OPTIONAL	1	
1◆	13012ZK7V01	RING SET, PISTON (OS 0.50), OPTIONAL	1	
1◇	13012Z4F004	RING SET, PISTON (OS 0.50), OPTIONAL	1	
1◆	13013ZK7V01	RING SET, PISTON (0.75), OPTIONAL	1	
1◇	13013Z4F004	RING SET, PISTON (0.75), OPTIONAL	1	
2◆	13101ZH7000	PISTON, STANDARD .....	1	S/N 3993725 AND BELOW
2◆	13101ZH7010	PISTON, STANDARD .....	1	S/N 3993726 AND ABOVE
2◇	13101Z0S810	PISTON, STANDARD .....	1	S/N 1120058 AND BELOW
2◇	13101Z0S811	PISTON, STANDARD .....	1	S/N 1120059 TO 1141323
2◇	13101ZH7020	PISTON, STANDARD .....	1	S/N 1141324 AND ABOVE
2◆	13102ZH7000	PISTON, OS 0.25 (OPTIONAL) .....	1	S/N 3993725 AND BELOW
2◆	13102ZH7010	PISTON, OS 0.25 (OPTIONAL) .....	1	S/N 3993726 AND ABOVE
2◇	13102Z0S810	PISTON, OS 0.25 (OPTIONAL) .....	1	S/N 1120058 AND BELOW
2◇	13102Z0S811	PISTON, OS 0.25 (OPTIONAL) .....	1	S/N 1120059 TO 1141323
2◇	13102ZH7020	PISTON, OS 0.25 (OPTIONAL) .....	1	S/N 1141324 AND ABOVE
2◆	13103ZH7000	PISTON, OS 0.50 (OPTIONAL) .....	1	S/N 3993725 AND BELOW
2◆	13103ZH7010	PISTON, OS 0.50 (OPTIONAL) .....	1	S/N 3993726 AND ABOVE
2◇	13103Z0S810	PISTON, OS 0.50 (OPTIONAL) .....	1	S/N 1120058 AND BELOW
2◇	13103Z0S811	PISTON, OS 0.50 (OPTIONAL) .....	1	S/N 1120059 TO 1141323
2◇	13103ZH7020	PISTON, OS 0.50 (OPTIONAL) .....	1	S/N 1141324 AND ABOVE
2◆	13104ZH7000	PISTON, 0.75 (OPTIONAL) .....	1	S/N 3993725 AND BELOW
2◆	13104ZH7010	PISTON, 0.75 (OPTIONAL) .....	1	S/N 3993726 AND ABOVE
2◇	13104Z0S810	PISTON, 0.75 (OPTIONAL) .....	1	S/N 1120058 AND BELOW
2◇	13104Z0S811	PISTON, 0.75 (OPTIONAL) .....	1	S/N 1120059 TO 1141323
2◇	13104ZH7020	PISTON, 0.75 (OPTIONAL) .....	1	S/N 1141324 AND ABOVE
3	13111ZE0000	PIN, PISTON	1	
4◆	132A0ZE0000	ROD ASSY., CONNECTING (UNDERSIZE) OPTIONAL	1	INCLUDES ITEMS W/\$
4◆	13200ZE0000	ROD ASSEMBLY, CONNECTING .....	1	INCLUDES ITEMS W/\$
4◇	13200Z0S800	ROD ASSEMBLY, CONNECTING .....	1	INCLUDES ITEMS W/\$
5\$	90001ZE1000	BOLT, CONNECTING ROD	2	
6	90551ZE0000	CLIP, PISTON PIN 13MM	2	

**NOTICE**

◆ GX120K1QX2: AUGUST 2008 AND BELOW

◇ GX120UT1QX2: SEPTEMBER 2008 AND ABOVE

# HONDA GX120K1QX2/UT1QX2 ENGINE — RECOIL STARTER ASSY.

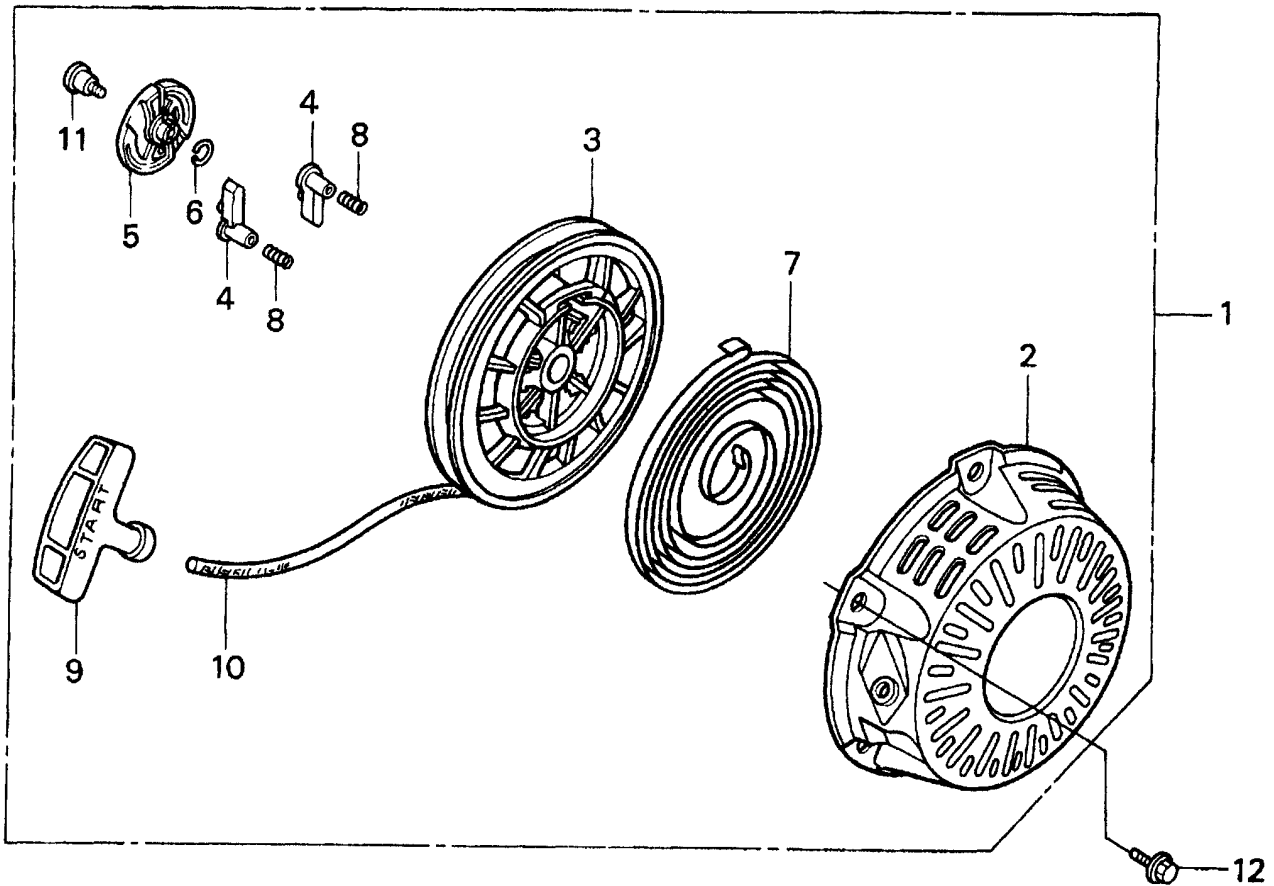

# HONDA GX120K1QX2/UT1QX2 ENGINE — RECOIL STARTER ASSY.

## RECOIL STARTER ASSY.

<u>NO.</u>	<u>PART NO.</u>	<u>PART NAME</u>	<u>QTY.</u>	<u>REMARKS</u>
1♦	28400ZH8013ZB	STARTER ASSY., RECOIL *NH1* (BLACK) .....	1 .....	INCLUDES ITEMS W/\$
1♦	28400ZH8013ZA	STARTER ASSY., RECOIL *R8* (RED).....	1.....	S/N 4142273 AND BELOW INCLUDES ITEMS W/\$
1♦	28400ZH8013YA	STARTER ASSY., RECOIL *R280* (RED).....	1.....	S/N 4142274 AND ABOVE INCLUDES ITEMS W/\$
1◇	28400ZH8023YA	STARTER ASSY., RECOIL *R280* (RED).....	1.....	INCLUDES ITEMS W/\$
2♦\$	28410ZH8003ZB	CASE, RECOIL STARTER *NH1* (BLACK)	1	
2♦\$	28410ZH8003ZA	CASE, RECOIL STARTER *R8*(RED) .....	1.....	S/N 4142273 AND BELOW
2♦\$	28410ZH8003YA	CASE, RECOIL STARTER *R280* (RED).....	1.....	S/N 4142274 AND ABOVE
2◇\$	28410ZH8003YA	CASE, RECOIL STARTER *R280* (RED)	1	
3♦\$	28420ZH8013	REEL, RECOIL STARTER	1	
3◇\$	28420ZH8801	REEL, RECOIL STARTER	1	
4♦\$	28422ZH8013	RATCHET, STARTER	2	
4◇\$	28422ZH8801	RATCHET, STARTER	2	
5\$	28433ZH8003	GUIDE, RATCHET	1	
5\$	28433ZH8801	GUIDE, RATCHET	1	
6♦\$	28441ZH8003	SPRING, FRICTION	1	
6◇\$	28441ZH8801	SPRING, FRICTION	1	
7\$	28442ZH8003	SPRING, RECOIL STARTER	1	
8♦\$	28443ZH8003	SPRING, RETURN	2	
8◇\$	28443ZH8801	SPRING, RETURN	2	
9\$	28461ZH8003	GRIP, RECOIL STARTER	1	
10\$	28462ZH8003	ROPE, RECOIL STARTER	1	
11\$	90003ZH8003	SCREW, SETTING	1	
12	90008ZE2003	BOLT, FLANGE 6X10	3	

### NOTICE

♦ GX120K1QX2: AUGUST 2008 AND BELOW

◇ GX120UT1QX2: SEPTEMBER 2008 AND ABOVE

# HONDA GX120K1QX2/UT1QX2 ENGINE — GASKET KIT ASSY.

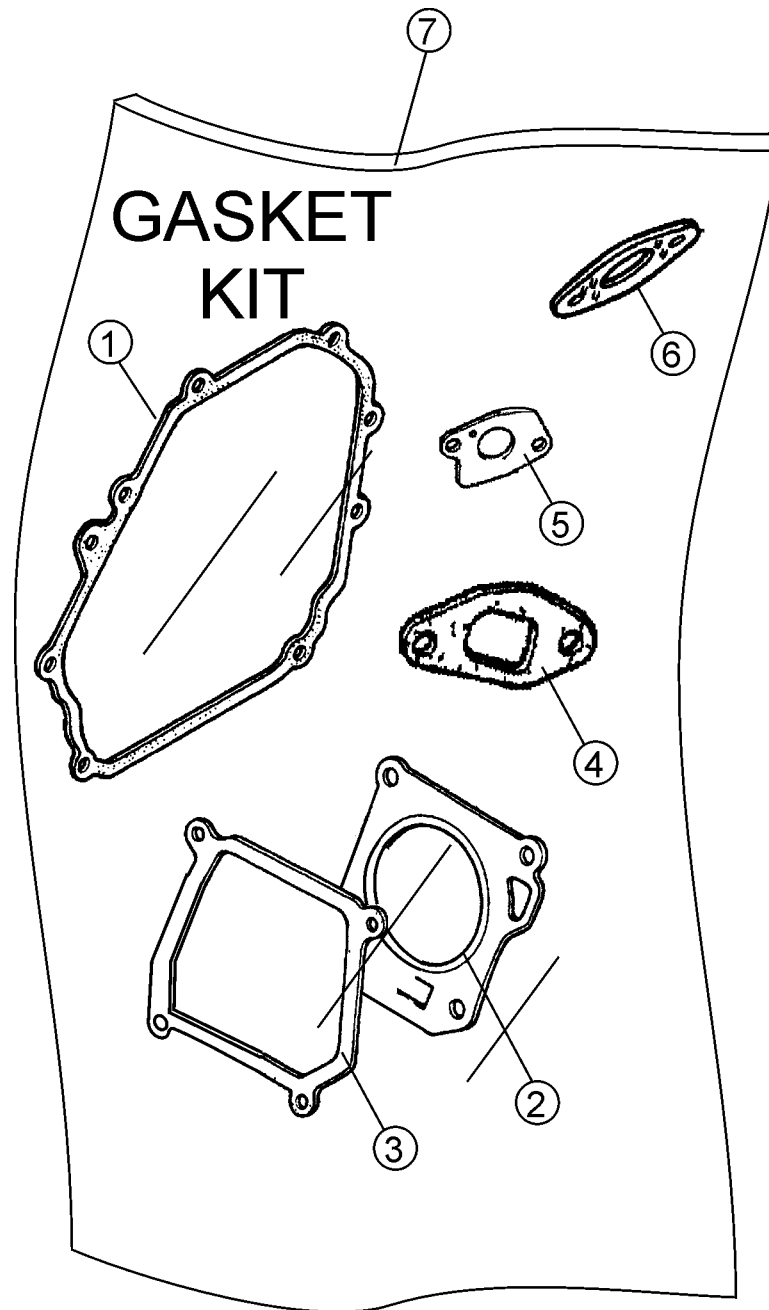

# HONDA GX120K1QX2/UT1QX2 ENGINE — GASKET KIT ASSY.

GASKET KIT ASSY.

<u>NO.</u>	<u>PART NO.</u>	<u>PART NAME</u>	<u>QTY.</u>	<u>REMARKS</u>
1\$	11381ZH7800	GASKET, CASE COVER	1	
2\$	12251ZH7800	GASKET, CYLINDER HEAD	1	
3\$	12391ZE1000	GASKET, CYLINDER HEAD COVER	1	
4\$	16212ZH7800	GASKET, INSULATOR	1	
5\$	16221ZH8801	GASKET, CARBURETOR	1	
6\$◆	18381ZH8800	GASKET, MUFFLER	1	
6\$◇	18381ZH8800	GASKET, MUFFLER.....	1.....	S/N 1060773 AND BELOW
6\$◇	18381Z0T801	GASKET, MUFFLER.....	1.....	S/N 1060774 AND ABOVE
7◆	06111ZH7405	GASKET KIT.....	1.....	INCLUDES ITEMS W/\$
7◇	061A1ZH7010	GASKET KIT.....	1.....	INCLUDES ITEMS W/\$

**NOTICE**

- ◆ GX120K1QX2: AUGUST 2008 AND BELOW
- ◇ GX120UT1QX2: SEPTEMBER 2008 AND ABOVE

# HONDA GX120K1QX2/UT1QX2 ENGINE — LABELS ASSY.

---

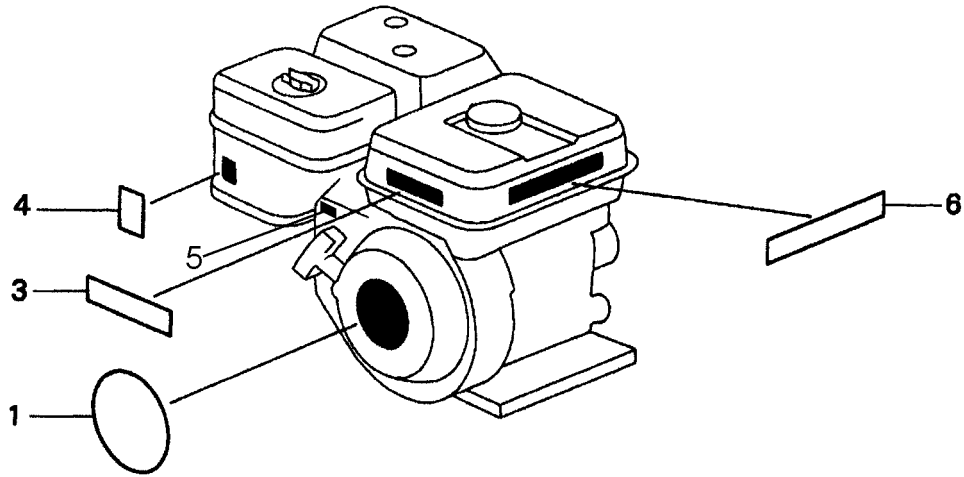

# HONDA GX120K1QX2/UT1QX2 ENGINE — LABELS ASSY.

## LABELS ASSY.

<u>NO.</u>	<u>PART NO.</u>	<u>PART NAME</u>	<u>QTY.</u>	<u>REMARKS</u>
1◆	87521ZH7010	EMBLEM.....	1.....	S/N 2185870 TO 3841370
1◆	87521ZH7020	EMBLEM.....	1.....	S/N 3841371 TO 4142243
1◆	87521ZH7030	EMBLEM (4.0) .....	1.....	S/N 4142244 AND ABOVE
1◇	87521ZH7030	EMBLEM, (4.0) .....	1.....	S/N 1120058 AND BELOW
1◇	87521ZH7040	EMBLEM, GX120.....	1.....	S/N 1120059 AND ABOVE
3◆	87522ZH9000	LABEL, CAUTION	1	
4◆	87528ZE1810	MARK, CHOKE	1	
4◇	87528ZH7000	MARK, CHOKE (GRAY)	1	
5	87532ZH7000	THROTTLE INDICATION	1	
6	87532ZH8810	MARK, OIL ALERT (E)	1	

### NOTICE

- ◆ GX120K1QX2: AUGUST 2008 AND BELOW
- ◇ GX120UT1QX2: SEPTEMBER 2008 AND ABOVE

# TERMS AND CONDITIONS OF SALE — PARTS

## PAYMENT TERMS

Terms of payment for parts are net 30 days.

## FREIGHT POLICY

All parts orders will be shipped collect or prepaid with the charges added to the invoice. All shipments are F.O.B. point of origin. Multiquip's responsibility ceases when a signed manifest has been obtained from the carrier, and any claim for shortage or damage must be settled between the consignee and the carrier.

## MINIMUM ORDER

The minimum charge for orders from Multiquip is \$15.00 net. Customers will be asked for instructions regarding handling of orders not meeting this requirement.

## RETURNED GOODS POLICY

Return shipments will be accepted and credit will be allowed, subject to the following provisions:

1. A Returned Material Authorization must be approved by Multiquip prior to shipment.
2. To obtain a Return Material Authorization, a list must be provided to Multiquip Parts Sales that defines item numbers, quantities, and descriptions of the items to be returned.
  - a. The parts numbers and descriptions must match the current parts price list.
  - b. The list must be typed or computer generated.
  - c. The list must state the reason(s) for the return.
  - d. The list must reference the sales order(s) or invoice(s) under which the items were originally purchased.
  - e. The list must include the name and phone number of the person requesting the RMA.
3. A copy of the Return Material Authorization must accompany the return shipment.
4. Freight is at the sender's expense. All parts must be returned freight prepaid to Multiquip's designated receiving point.

5. Parts must be in new and resalable condition, in the original Multiquip package (if any), and with Multiquip part numbers clearly marked.
6. The following items are not returnable:
  - a. Obsolete parts. (If an item is in the price book and shows as being replaced by another item, it is obsolete.)
  - b. Any parts with a limited shelf life (such as gaskets, seals, "O" rings, and other rubber parts) that were purchased more than six months prior to the return date.
  - c. Any line item with an extended dealer net price of less than \$5.00.
  - d. Special order items.
  - e. Electrical components.
  - f. Paint, chemicals, and lubricants.
  - g. Decals and paper products.
  - h. Items purchased in kits.
7. The sender will be notified of any material received that is not acceptable.
8. Such material will be held for five working days from notification, pending instructions. If a reply is not received within five days, the material will be returned to the sender at his expense.
9. Credit on returned parts will be issued at dealer net price at time of the original purchase, less a 15% restocking charge.
10. In cases where an item is accepted, for which the original purchase document can not be determined, the price will be based on the list price that was effective twelve months prior to the RMA date.
11. Credit issued will be applied to future purchases only.

## PRICING AND REBATES

Prices are subject to change without prior notice. Price changes are effective on a specific date and all orders received on or after that date will be billed at the revised price. Rebates for price declines and added charges for price increases will not be made for stock on hand at the time of any price change.

Multiquip reserves the right to quote and sell direct to Government agencies, and to Original Equipment Manufacturer accounts who use our products as integral parts of their own products.

## SPECIAL EXPEDITING SERVICE

A \$35.00 surcharge will be added to the invoice for special handling including bus shipments, insured parcel post or in cases where Multiquip must personally deliver the parts to the carrier.

## LIMITATIONS OF SELLER'S LIABILITY

Multiquip shall not be liable hereunder for damages in excess of the purchase price of the item with respect to which damages are claimed, and in no event shall Multiquip be liable for loss of profit or good will or for any other special, consequential or incidental damages.

## LIMITATION OF WARRANTIES

No warranties, express or implied, are made in connection with the sale of parts or trade accessories nor as to any engine not manufactured by Multiquip. Such warranties made in connection with the sale of new, complete units are made exclusively by a statement of warranty packaged with such units, and Multiquip neither assumes nor authorizes any person to assume for it any other obligation or liability whatever in connection with the sale of its products. Apart from such written statement of warranty, there are no warranties, express, implied or statutory, which extend beyond the description of the products on the face hereof.

Effective: February 22, 2006





# PARTS MANUAL

## HERE'S HOW TO GET HELP

PLEASE HAVE THE MODEL AND SERIAL  
NUMBER ON-HAND WHEN CALLING

### UNITED STATES

#### ***Multiquip Corporate Office***

18910 Wilmington Ave.  
Carson, CA 90746  
Contact: mq@multiquip.com

Tel. (800) 421-1244  
Fax (310) 537-3927

#### ***Service Department***

800-421-1244  
310-537-3700

Fax: 310-537-4259

#### ***Technical Assistance***

800-478-1244

Fax: 310-943-2238

#### ***MQ Parts Department***

800-427-1244  
310-537-3700

Fax: 800-672-7877  
Fax: 310-637-3284

#### ***Warranty Department***

800-421-1244  
310-537-3700

Fax: 310-943-2249

### CANADA

#### ***Multiquip***

4110 Industriel Boul.  
Laval, Quebec, Canada H7L 6V3  
Contact: infocanda@multiquip.com

Tel: (450) 625-2244  
Tel: (877) 963-4411  
Fax: (450) 625-8664

### UNITED KINGDOM

#### ***Multiquip (UK) Limited Head Office***

Unit 2, Northpoint Industrial Estate,  
Globe Lane,  
Dukinfield, Cheshire SK16 4UJ  
Contact: sales@multiquip.co.uk

Tel: 0161 339 2223  
Fax: 0161 339 3226

© COPYRIGHT 2015, MULTIQUIP INC.

Multiquip Inc, the MQ logo and the Whiteman logo are registered trademarks of Multiquip Inc. and may not be used, reproduced, or altered without written permission. All other trademarks are the property of their respective owners and used with permission.

This manual MUST accompany the equipment at all times. This manual is considered a permanent part of the equipment and should remain with the unit if resold.

The information and specifications included in this publication were in effect at the time of approval for printing. Illustrations, descriptions, references and technical data contained in this manual are for guidance only and may not be considered as binding. Multiquip Inc. reserves the right to discontinue or change specifications, design or the information published in this publication at any time without notice and without incurring any obligations.

Your Local Dealer is:



**P/N 21692**