



Click Here To View  
Item at

[www.GapPower.com](http://www.GapPower.com)

*Sales • Rentals  
Parts & Service*

# Electric Eel<sup>®</sup>

## MODEL C Dual Cable

### Operator's Manual



**!! DANGER !!**

**FOR YOUR SAFETY**

Before you operate or maintenance this equipment, READ this manual carefully and completely!

**Purchase Date:** \_\_\_\_\_

**Serial Number:** \_\_\_\_\_



**ELECTRIC EEL MANUFACTURING CO., INC.**

501 West Leffel Lane, Springfield, Ohio 45501-9985

Call Toll-Free (800) 833-1212 (937) 323-4644 FAX: (937) 323-3767

[www.electriceel.com](http://www.electriceel.com)

*Proudly Made in The USA Since 1939*

**READ THIS MANUAL CAREFULLY.**

With proper care and operation, your Model C Dual Cable Electric Eel will give you years of satisfactory service.

# Description/Specifications

## DESCRIPTION

The ELECTRIC EEL Model C Drain Cleaning Machine is typical of nearly half a century of ELECTRIC EEL's dependable, rugged, and versatile line of quality sewer and drain cleaning equipment. This machine is specifically designed for the professional when cleaning 3 to 10 inch diameter lines and using up to 200 feet of cable.

## SPECIFICATIONS

Line Capacity .....	3 to 10" dia. with up to 200 feet of cable.
Weight .....	75 lbs. (Machine only)
Frame .....	1" open space framework of welded tube, with a cast Aluminum base.
Tires .....	10" solid rubber.
Power .....	1/2 HP Capacitor Start motor. (115 V AC standard), (Optional 3/4 and 1 HP, in addition, 220 Volt, 60 Cycle, and 230 Volt, 50 cycle are also available). Standard: 1 1/4" diameter x 8' cable sections.
Optional J Cable .....	7/8" diameter x 6' sections.
Controls .....	20 ft. cord assembly with reversing switch and built-in ground fault circuit interrupter, and momentary actuator switch with 15 ft. cord.
Operator and Safety Manual	
Note .....	All new units include cleaning tools, (as outlined on the top of page 8), plus one cable spanner wrench.

To obtain any additional information regarding the Model C Dual Cable Electric Eel, please write Electric Eel Manufacturing Company, Inc., Dept. R, 501 W. Leffel Lane, Springfield, Ohio 45501. Or contact us at 1-800-833-1212.

## Safety Instructions

The following safety rules for operating ELECTRIC EEL the Model C Sewer and Drain Cleaning equipment **MUST** be read and followed carefully before operating this machine.



**! DANGER !**

To prevent serious injuries including:

- Shock, electrocution or burns due to improper grounding.
- Serious injuries to body, limbs or hands and feet due to cables that twist, kink and break.
- Eye injuries caused by loose cable, thrown debris or splashed water.

---

**READ SAFETY INFORMATION THOROUGHLY!**

## ! DANGER !

### TO PREVENT SERIOUS BODILY INJURY AND AVOID DANGER FROM ROTATING CABLES AND EQUIPMENT:

#### GENERAL SAFETY

1. **ALWAYS** wear **HEAVY** reinforced leather gloves and **SAFETY** glasses when operating this equipment.
  2. Place this machine within 8 feet of inlet, and **NEVER** add more than **ONE 8' SECTION** of cable at a time between sewer opening and machine.
  3. **NEVER** handle rotating cable or cable under tension.
  4. **DO NOT WEAR** loose clothing or jewelry while operating this machine.
  5. The Model C Sewer and Drain Cleaning Machine should be **OPERATED BY ONE PERSON ONLY**. Additional personnel in the work area **MUST** observe all safety instructions.
  6. Wear rubber soled **NON-SLIP SHOES, HEAVY LEATHER** gloves, and **EYE Protection**.
  7. **ALWAYS AVOID** direct contact of skin, facial area and especially the **EYES** with drain water. Chemical compounds used in drains can result in serious burns and other injuries.
  8. **REPLACE** fittings, cables, and any rotating parts as soon as they become visibly worn. **REPLACE** any cables which become fractured, bent, kinked, or are otherwise damaged.
  9. **NEVER** attempt to service equipment beyond the recommendations of the operating instructions. All other servicing should be referred to qualified Electric Eel service personnel.
  10. To maintain safe operation, **USE ONLY** identical replacement parts and cables from Electric Eel.
  11. **ALWAYS KEEP CLEAR** of rotating shafts, pulleys, belts, or other rotating parts.
  12. **DO NOT** continue to operate machine when cleaning tool becomes stuck in obstruction. **EXCESS TORQUE ON A CABLE COULD CAUSE IT TO FRACTURE. RELEASE CABLE TENSION** to prevent unnecessary build-up of torque on the cable. Keep machine under control at all times. (Refer to operating instructions to free cleaning tool).
  13. **NEVER HANDLE ANY CABLE UNDER TENSION.\*** **ALWAYS** relieve tension on the cable by reverse rotation or by turning the switch off and unplugging the cord.
  14. **NEVER** force a tool and cable into pipeline blockage. This may overload the cable or tool and cause it to fracture.
  15. Use **CORRECT TOOL** for the job or application. Check the tool chart and use the proper tool for the size of the line being cleaned.
  16. To maintain safe and efficient operation **CLEAN THOROUGHLY** all cables and tools with water after use. Acids in the drain and sewer lines can attack and deteriorate the metal of the cables and tools. Deterioration can cause premature fracture or breakage in tools or cable.
- \*Relieve all tension build-up before attempting to handle cable.

## ! DANGER !

### TO AVOID SERIOUS BODILY INJURY AND TO AVOID DANGER FROM ELECTRICAL SHOCK:

#### GENERAL SAFETY—ELECTRICAL

1. **ALWAYS** use a ground fault interrupted circuit with a properly grounded outlet for all electrical cords, connections, and parts as installed by factory. **DO NOT** make any alterations.

2. **NEVER** use machine while standing in damp or wet conditions.
3. **NEVER** expose machine to rain.
4. **THE USER SHOULD NEVER ATTEMPT TO SERVICE THE ELECTRICAL COMPONENTS.** For safety reasons all electrical replacement components should be installed by a qualified electrician.
5. **BEFORE MAKING ADJUSTMENTS OR CHANGES TO POWER UNITS, DISCONNECT FROM ELECTRICAL SOURCE.**

## THE GROUND FAULT CIRCUIT INTERRUPTER

This machine is equipped with a **Ground Fault Circuit Interrupter** which is designed to prevent a serious electrical shock. This device should be **TESTED** on the job site **BEFORE** putting the machine into operation, as follows:

1. To ensure protection against electrical shock, test the device before each use. When test button is pushed in, the indicator light should go OFF. Reactivate the device by pushing the reset button in. If the indicator light goes ON, the device is ready for use. **DO NOT** use the device, if the indicator light does not go ON WHEN RESET or if the indicator light REMAINS ON, when the TEST BUTTON IS PUSHED IN.
2. This device **DOES NOT** guard against electric shock resulting from defects or faults in any wiring supplying power to this device, or from contact with both circuit conductors.
3. **DO NOT** use with an extension cord on the plug end.
4. If an extension cord is used, the power source **MUST** be equipped with a ground fault interrupter circuit and properly grounded.
5. **ONLY** use 14 ga. or larger, three-wire, extension cord, (with ground wire), with three prong grounding plugs and three pole receptacles.
6. When using extension cord outdoors, **ONLY** use those intended for outdoor use. (Indicated on cord by suffix, "W-A", after cord type).

## Assembly Instructions



**TO PREVENT SERIOUS BODILY INJURY, FOLLOW THESE INSTRUCTIONS CAREFULLY:**

**TOOLS REQUIRED: Screwdriver, Adjustable Wrench, Ratchet w/1/2" Socket, Hammer**

1. Tilt drive unit back so bottom of base (#11) is facing front.
2. Mount 5" swivel caster (#15) with the (4) 1/4"-20 x 5/8" caster screws (#16) and washers (#17) provided inside the operator's manual package.
3. Loosen allen head screw (#18) at bottom of base with allen wrench provided. Insert axle (#12) through sides of base with equal clearance on both sides. Tighten allen screw (#18) firmly. Install (1) 10" dolly wheel (#13) on each side and secure with 1/2" pushnut (#14) provided. Tap pushnut on with hammer.
4. Sit machine upright with back of drive unit facing assembler. Remove folding handle and bracket assembly (#1) from carton and position DL-10 brackets (#5) on base while lining up holes with bracket and base. Insert (4) bolts (#6) with 5/16" flat washer (#7) through top of DL-10 bracket. Secure same with (4) 5/16" nuts (#9) and 5/16" lock washers (#8) from bottom of base.

5. Secure (2) electrical cords to folding handle crossbar with (2) plastic electrical clamps and 10-24 x 3/8" screw provided. Be sure to leave a 3-4" cord clearance from motor switch box to handle to insure folding handle can be in the fold-down position when required.
6. Wrap electrical cords to sides of folding handle, GFI (#25) on left side, M-10-AY cord (#20) and switch on right side.
7. Secure blue M-10-AY electrical switch (#22) in switch clip (#3) on top right hand side of handle.
8. Plug GFI into 120V/60Hz outlet, press test, light will go on. Press reset, power will indicate unit is ready for use.

**NOTE:** Refer to enclosed schematic drawing to reference part numbers.

## THE MOTOR

The motor is of the heavy duty, capacitor start type and is back geared to give an output speed of 500 RPM—and is equipped with an electrical reverse.

A 1/2 HP 115 Volt, 60 cycle motor is standard but 3/4 and 1 HP are also available. 220 Volt, 50 cycle and 230 Volt, 60 cycle are also available. Under prolonged and heavy loading the motor may become **VERY HOT**. You should not try to put any part of your body against the motor. This is the response of a motor to heavy loading, (ie: heavier loading equals higher current and higher motor temperatures), it will not normally damage the motor or the bearings.

The motor bearings are of the grease-sealed type and should not require any further lubrication.

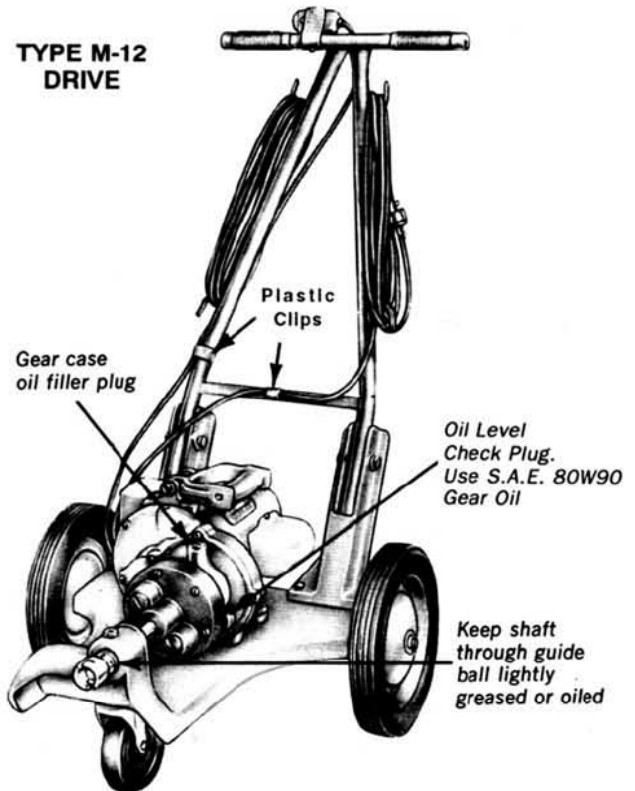

## THE CLUTCH

The purpose of the friction disc clutch, which is located on the back gear shaft, is to prevent damage to the cable and cleaning tool whenever they become momentarily stuck in an obstruction. This clutch has been set at the factory at a torque of 100 inch pounds. This is the proper adjustment for most jobs.

**WARNING:** When using the Model J cable—Reduce Clutch setting to 50 inch pounds torque. Should it be necessary to change this clutch adjustment because of wear or any other reason, adjustment should be performed as follows:

Loosen the two clutch adjusting screws an equal amount to a point where the drive unit will turn the cable—but where the clutch will slip when the slightest obstruction is encountered. Then, tighten the clutch by giving each adjusting screw one-half turn until the clutch will slip only under moderate loading.

**AFTER ANY ADJUSTMENT IS MADE TO THE CLUTCH TO ALTER ITS TORQUE FOR A LIMITED PERIOD OF TIME ON A SPECIFIC JOB, ALWAYS RETURN THE TORQUE SETTINGS TO THE FACTORY SPECIFICATION OF 100 INCH POUNDS.**

An accurate setting should be made by:

1. Obtaining an inch/lbs. torque wrench and adapter from ELECTRIC EEL.
2. Attach the adapter to the drive fitting of the Model C machine and follow instructions included with the adapter.

## THE CABLE

The Dual Cable is composed of a right hand wound, open spaced, outer steel spring and a left hand wound, closed spaced, inner steel spring which are joined at each end with couplings. This construction provides a strong, flexible cable that self-feeds through the pipeline in either direction.

Cable sections and tools are joined by firmly pressing the fittings together and turning the cables or tools a quarter turn to engage the snap lock pin.

Cables and cleaning tools are disconnected by using the spanner wrench, (available from ELECTRIC EEL), by disengaging the locking pin and turning a quarter turn in the opposite direction, as shown below. The Dual Cable sections require periodic maintenance—usually just an occasional oiling of the snap lock pin in the male coupling.

If the cables are to be stored for several weeks between jobs, a light coating of oil will prevent rusting.

## Operating Instructions



**OPERATOR MUST BE THOROUGHLY FAMILIAR WITH ALL SAFETY INSTRUCTIONS BEFORE OPERATING THIS EQUIPMENT.**

1. If at all possible, the nature and approximate location of the stoppage should be determined before starting the job. Usually a drain or sewer line obstruction is removed by running the cleaning tool downstream until the obstruction is reached.
2. The cleaning tool should be chosen according to the enclosed information for the line size being cleaned.
3. The cleaning tool reduces the obstruction to small pieces, which are then washed downstream by the flow of water. In such cases, after clearing the obstruction, you should use as much water in the line as possible.
4. Check for clean outs—and, where possible, avoid traps by using an opening beyond the trap.
5. Wheel the machine into the space where the work is to be done. Remove as many 8' sections of cable from the cable container as operating space will permit—and use a spanner wrench to separate the cables.

6. Then connect the proper tool to the first section of cable and insert it into the opening of the pipeline that is to be cleaned. If it enters the pipeline freely, feed it in by hand until an obstruction is met. Then, attach the cable to the machine. **BEFORE TURNING ON THE MOTOR, BE SURE THE REVERSING SWITCH IS ON "FORWARD".**
7. If the opening is trapped, you must use the feeding tool to start the cable into the line. The FEEDING TOOL is held against the rotating cable so that the cable feeds into the pipeline far enough to gain its own footing. Remove the starting switch from its bracket and use it and the feeding tool as shown in Figure 5.
8. As soon as the cleaning tool has negotiated the trap, shut off the motor and return the switch to the bracket. **AVOID "P" traps in 3" diameter pipelines as they can cause severe cable damage. We recommend our Model J cables and cleaning tools for this application.**
9. To add additional 8' cable sections use the following procedure, but **NEVER** add more than **ONE 8' SECTION** of cable at a time between sewer opening and machine. Feed the added section into the pipeline until the machine is two or three feet from the opening. Then add another length of cable. The open spaced, right hand wound construction of the outer cable member provides a self-feeding action and exerts an even pressure against the pipeline stoppage. If the safety clutch slips, put the machine in reverse and back away momentarily from the obstruction.
10. Work the cable back and forth—by alternating the motor in reverse and forward for a few seconds in each direction—until the initial opening in the obstruction is made. It is not necessary to let too much cable out of the line. A foot or two backward and forward several times usually does the job. Repeated slippage may indicate a broken or damaged pipeline. **AVOID** slack in the cable between the machine and the pipeline opening—as this is the area where cable will have a tendency to loop and then kink and become damaged and/or could cause serious injury.
11. Repeat this operation until flow is established. **WHEN POSSIBLE, KEEP PLENTY OF FRESH WATER RUNNING THROUGH THE LINE WHILE WORK IS BEING DONE.** This allows the obstruction, broken loose by the cleaning tool, to be flushed out. This also allows the cable to be washed off when it is withdrawn from the pipeline. It is important to wash off the cable in this manner—or with a hose—immediately after the job is completed. This prevents damage to the cable and tools by the chemicals present in drains and sewers.
12. After the initial opening is made, reverse the motor to feed the cable out of the line. Use the proper tool to complete the job.

Occasionally, a tool will hang up on some obstruction and will not feed back. If this happens, put the motor in forward rotation and pull back on the dolly until the tool is past the obstruction. Then, put the machine in reverse and the tool will feed out.

## CLEANING TOOLS

The cleaning tools shown on the following page fall basically into two categories: (1) starting tools which have drill or spade points, and (2) finishing tools which usually are of a flat spring design with serrated edges. 3" and 4" diameter lines can usually be cleaned by using the starting tool to make the initial opening—and then using the finishing tool for the second run through the line.

## Electric Eel Dual Cable Details

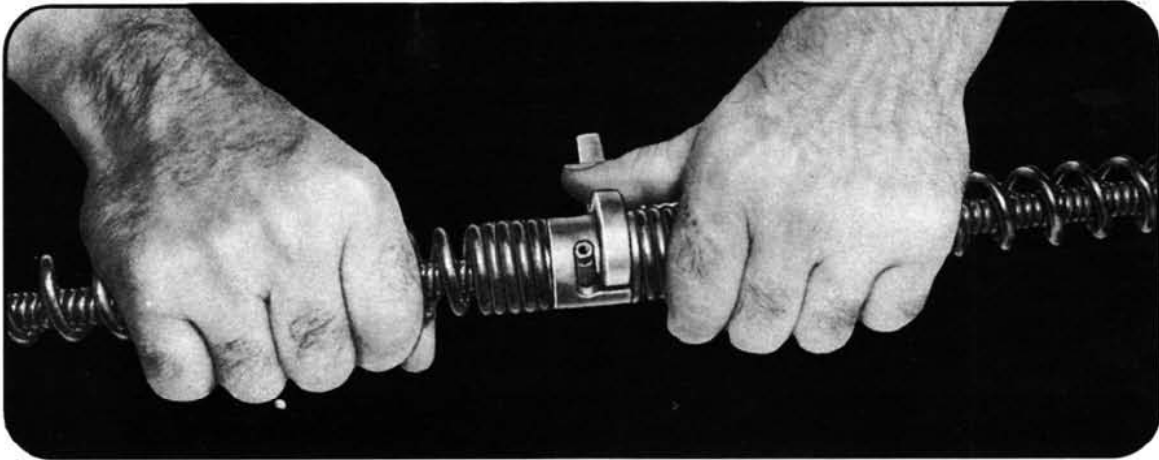
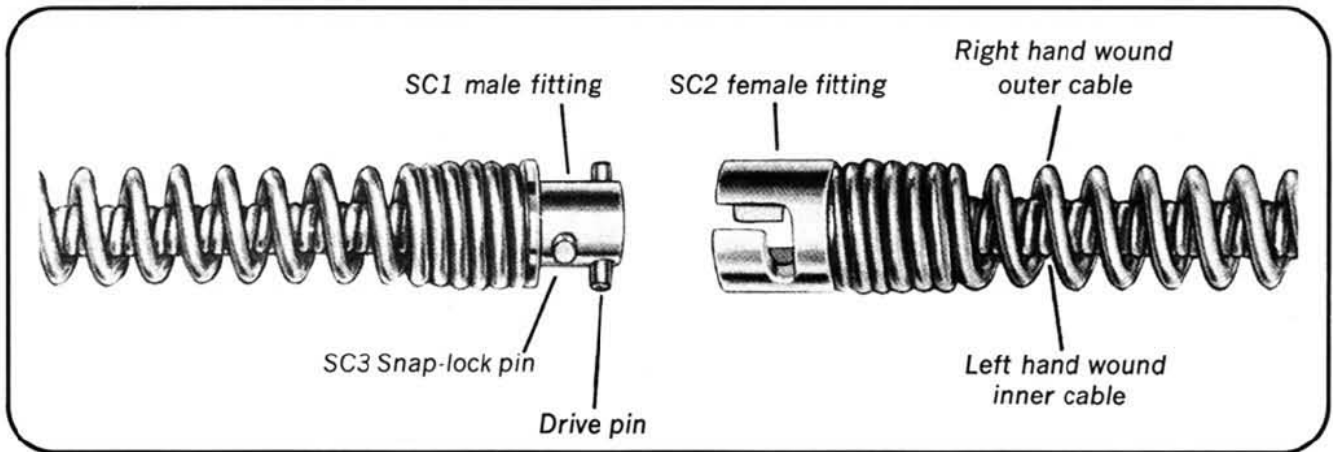
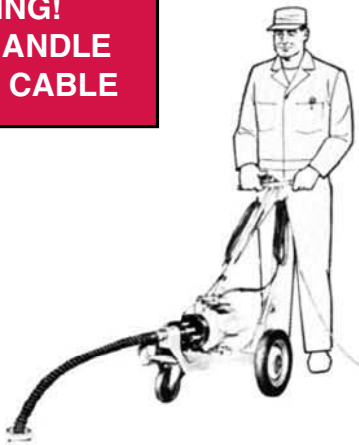

Figure 2 Separating cables with spanner wrench



**WARNING!**  
DO NOT HANDLE  
ROTATING CABLE



*The Model C Electric Eel has a folding handle so that it may be easily transported and stored. You will find that this feature is also advantageous when you are working in crawl spaces.*

Badly blocked pipelines usually require more than two runs through the line. Progressively larger cleaning tools should be used on each run until the line is cleaned to its original diameter.

**EXAMPLE:** A badly blocked 4" pipeline should be opened with the A-1DC tool. The HDD-3S tool should be used for the second run. The finishing run should be made with the HDD-4S tool—or with the A-14DC tool if entrance is made through a "P" trap.

Since the dual cable imparts a whipping action to the cleaning tool, the opening made in the pipeline obstruction is approximately 1/2" to 1" larger in diameter than the cleaning tool.



# MODEL C DRAIN CLEANING MACHINE

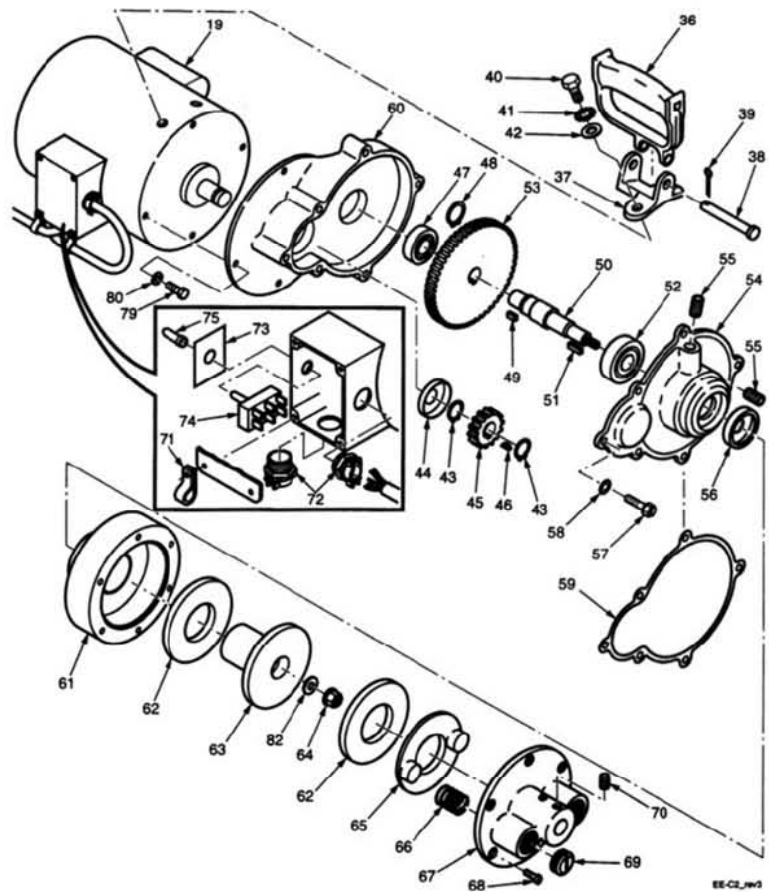
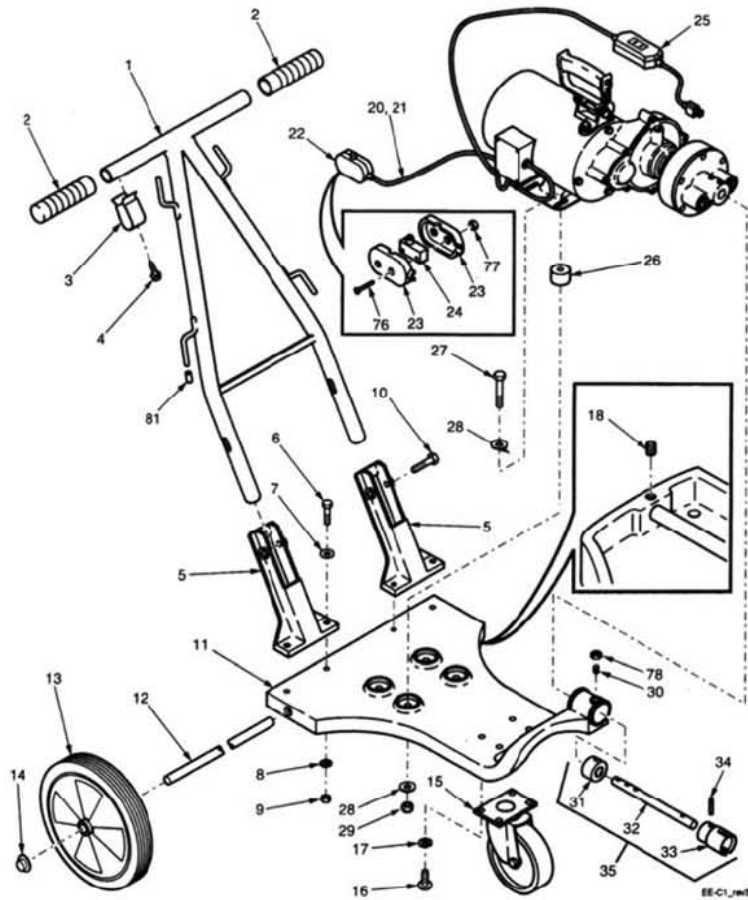

## MODEL C DRAIN CLEANING MACHINE

ITEM #	PART #	DESCRIPTION	AMT	ITEM #	PART #	DESCRIPTION	AMT
1	DL-9*	Folding Handle	1	40	CSHH5161858	Handle Capscrew	2
2	HG	Handle Grips	2	41	LW516E	Handle Lockwasher	2
3	DL-7	Switch Clip	1	42	WA516S	Handle Flat Washer	2
4	SM121H	Switch Clip Screw	1	43	RR66	Retaining Ring	2
5	DL-10	Bracket (Base of Folding Handle)	2	44	471553	Rear Oil Seal for Motor Shaft	1
6	CSHH51618112	Bracket Capscrews	4	45	KC-4	Small Gear w/Key	1
7	WA516S	Bracket Washers	4	46	WK3	Woodruff Key	1
8	LW516	Bracket Lockwashers	4	47	6203ZZ	Rear Ball Bearing	1
9	NU51618FHP	Bracket Nuts	4	48	RR75	Retaining Ring	1
10	CSHH3816214	Folding Handle Capscrews	2	49	K31612	Key	1
11	M-12	Drive Unit Base	2	50	KC-8	Back Gear Shaft	1
12	M-13	Axle	1	51	K31634	Key	1
13	C-W10	10" Diameter x 5/8 Wheels	2	52	6304ZZ	Front Ball Bearing	1
14	PN12	Pushnuts	2	53	KC-7	Large Gear w/Key.	1
15	C-SWC	Swivel Caster	1	54	KC-3	Gear Case Cover	1
16	MS142058RH	Caster Screw	4	55	PP18	Pipe Plug	2
17	LW14	Caster Lockwasher	4	56	7829CR	Front Oil Seal for Back Gear Shaft	1
18	SS5161812	Axle Setscrew	1	57	MS102434HHWS	Gear Case Cover Screws	6
19	CM-1/2**	1/2 H.P. Replacement Motor	1	58	LW10E	Gear Case Cover Lockwashers	6
	CM-3/4	3/4 H.P. Replacement Motor	1	59	KC-5	Gear Case Gasket	1
	CM-1	1 H.P. Replacement Motor	1	60	KC-2	Gear Case	1
20	C-HSCD-A	15 Ft. 14/2 W/M-10AY Hand Switch	1	61	GE-30	Clutch Body	1
21	C-HSCD	15 Ft. 14/2 Cord Only 0 (Less Hand Swtich)	1	62	E-2	Clutch Friction Disc	2
22	M-10AY*****	Hand Switch with Case Assy	1	63	E-3	Clutch Drive Member	1
23	M-10	Switch Case Only	1	64	NU3824NY	Back Gear Shaft Nut	1
24	YA-2	Momentary Contact Switch (Less Case)	1	65	GE-33	Clutch Pressure Plate	1
25	GFCI	Ground Fault Circuit Interrupter 20' Cord	1	66	E-4	Clutch Spring	2
26	M-7	Rubber Mounts	4	67	GE-31	Clutch Cover Plate	1
27	CSHH516182	Rubber Mount Capscrews	4	68	MS142058FLH	Screw	6
28	WA516P	Rubber Mount Flatwashers	8	69	E-7	Clutch Adjusting Screw	2
29	NU51618NY	Rubber Mount Nuts	4	70	SS5161834	Socket Head Setscrew Anchors Item 35	2
30	SS381634DP	3/8-16 x 3/4 Set Screw Dog Point	1	71	CH31S10	Wire Clamp	2
31	SC-11	Guide Ball	1	72	C-TSC12	Screw Connector	2
32	SC-12	Shaft	1	73	SW-FRP	Forward/Reverse Switch Plate	1
33	SC-10	Front Coupling	1	74	SW-FR	Reversing Switch	1
34	RP316118	Spiral Pin	1	75	SW-BOOT	Toggle Switch Boot	1
35	SC-10A***	Fitting	1	76	MS8321FH	Switch Case Screws	2
	M-4A*****	Carry Handle	1	77	NU832FHP	Switch Case Nuts	2
36	M-4	Carry Handle	1	78	NU3816J	3/8-16 Jam Nut	1
37	M-5	Bracket	1	79	CSHH38161	3/8-16 x 1 Hex Head Capscrew	3
38	M-3****	Handle Pin	1	80	LW38I	3/8 Lockwasher-Internal	3
39	CP33234	Cotter Pin	1	81	DL6CAP	Cord Hook Cap	4
				82	WA38S	3/8 Flatwasher	1

\* DL-9A-Folding Handle Complete with Hardware. Includes items 1-10 and 81

\*\* Includes Items 71-75

\*\*\* Includes Items 31-34

\*\*\*\* Includes Item 39

\*\*\*\*\* Includes Items 23, 24, 76, 77

\*\*\*\*\* Includes Items 36, 37, 38



## Standard Equipment

## Plumbers Kit



Optional Cable Cart  
for easy transport

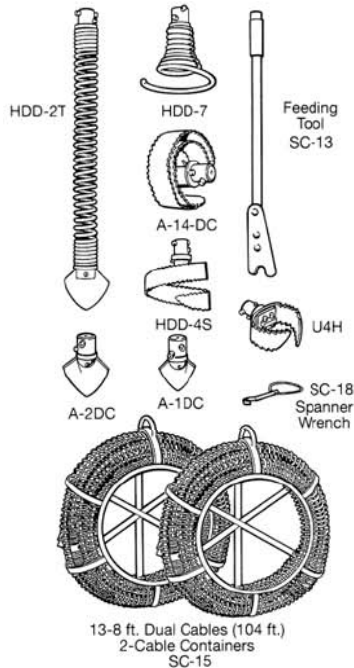

### Initial Opening Tools.

- HDD-2T – 2-3/8" diameter for 4" or larger pipeline
- A-1DC – 1-7/8" diameter for 3" or larger pipeline
- A-2DC – 2-3/8" diameter for 4" or larger pipeline

### Finishing Tools.

- A-14DC – 3-1/2" diameter for 4" pipelines and "P" traps

### Heavy Duty Tools.

- HDD-4S – 3" diameter for difficult obstructions in 4" or larger pipelines
- U4H – heavy duty tool for removing grease in 4" pipelines

### Retrieving Tools.

- HDD-7 – Retrieves broken cable or tools from pipeline

**Feeding Tool.** Helps operator start cable through traps or severe bends

**Cable Container.** Provides convenient handling and storage of up to 56 feet of cable

**Spanner Wrench.** (SC-18) Disconnects cables and tools

**Note:** See rental brochure for standard equipment in Rental Kit



**NEW** Optional Sludge Buster Tools

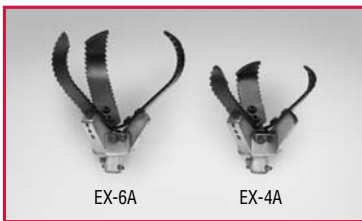

Optional Expansion Tools

## Optional Equipment

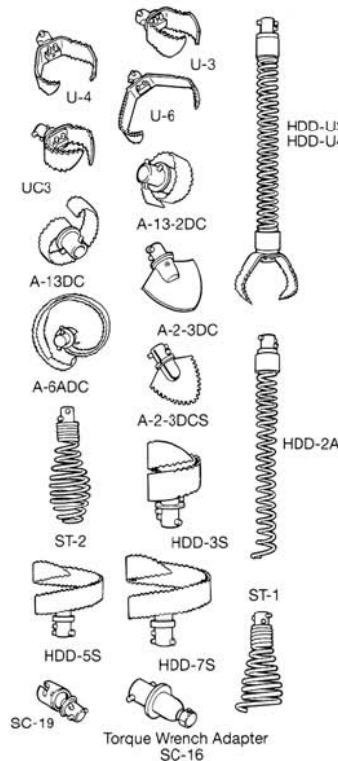

### Grease Removing Tools.

- U-3 – for 3" pipelines
- U-4 – for 4" pipelines
- U-6 – for 6" pipelines
- UC3 – for 3" pipelines

### Finishing Tools.

- A-2-3DC – 3" diameter for 4" or larger pipelines
- A-13-2DC – for 3" conductor lines
- A-13DC – for 4" conductor lines
- A-6ADC – 5" diameter for 6" pipelines
- A-2-3DC Special – chops ice in 4" pipelines
- ST-2 – bulb-shaped cleaning tool for 4" plastic pipeline

### Heavy Duty Tools.

- HDD-3S – for 3" or larger pipelines
- HDD-5S – for 6" pipelines
- HDD-7S – for 8" pipelines

### Retrieving Tools.

- ST-1 – right wound retriever
- HDD-2A – longer, thinner right wound retriever

### Flexible Spring Tools.

- HDD-U3 – 12" diameter spring with U3 blade for 3" pipelines
- HDD-U4 – 12" diameter spring with U4 or HD blade for 4" pipelines

### Accessories.

- SC-19 – provides swivel joint between cleaning tools and cable
- SC-16 – Torque Wrench Adapter



## ELECTRIC EEL MANUFACTURING CO., INC.

501 West Leffel Lane, Springfield, Ohio 45501-9985

Call Toll-Free (800) 833-1212 (937) 323-4644 FAX: (937) 323-3767

www.electriceel.com

Proudly Made in The USA Since 1939

Rev. 01/2012 I-7