

# Allmand®

## MAXI-HEAT®

MH500iQ™

The **Maxi-Heat® MH500iQ™** is designed to provide heat in harsh conditions with two independently operating heater units providing up to a combined 1,000,000 BTUs of heat. The iQ system automatically calibrates each heater unit so you don't have to change nozzles or test and retest with a smoke spot tester. The iQ system continuously monitors the heater, producing a higher degree of fuel efficiency with less soot and smoke. With a Fluid Containment System (FCS) and a single cell, double wall steel fuel tank, this heater is a top choice for worry free jobsites.



A SUBSIDIARY OF



BRIGGS & STRATTON  
CORPORATION

# KEY FEATURES

Maxi-Heat® MH500iQ™



## Reversible Coupler

Adjustable height 2" Bulldog® and 3" pintle

## 16" or Dual 12" Duct Flange Outlets

**iQ System** Automatically calibrates burner for temperature, humidity and barometric pressure. Provides damper setting on color display, and information on efficiency, target and actual outlet temperatures.

**Fluid Containment System (FCS)** Holding up to 110% of all on-board fluids

## Single Cell Double Wall Steel Fuel Tank

**Twin Heater Unit Produces 1,000,000 Combined BTUs**  
(515,000 BTU per burner)

**Ability to Operate Single Burner at 515,000 BTUs**

**Heater Unit (2) MCS500iQ™** indirect-fired heating units

Model	MH-C1.5	MH-I3CE
Engine Brand	Caterpillar	Isuzu
Engine Model	C1.5	3CE
Phase	1-phase	1-phase
Prime Power (kW)*	9	9
Fuel Capacity gal (L)	175 (662.4)	175 (662.4)
Operating Time (hrs)**	30.2	30
Heated Air Output (cfm)	3,200	
<b>Weights</b>		
Shipping Weight lbs (kg)	4,620 (2,095)	
Gross Vehicle Weight Rating (GVWR) lbs (kg)	6,000 (2,722)	

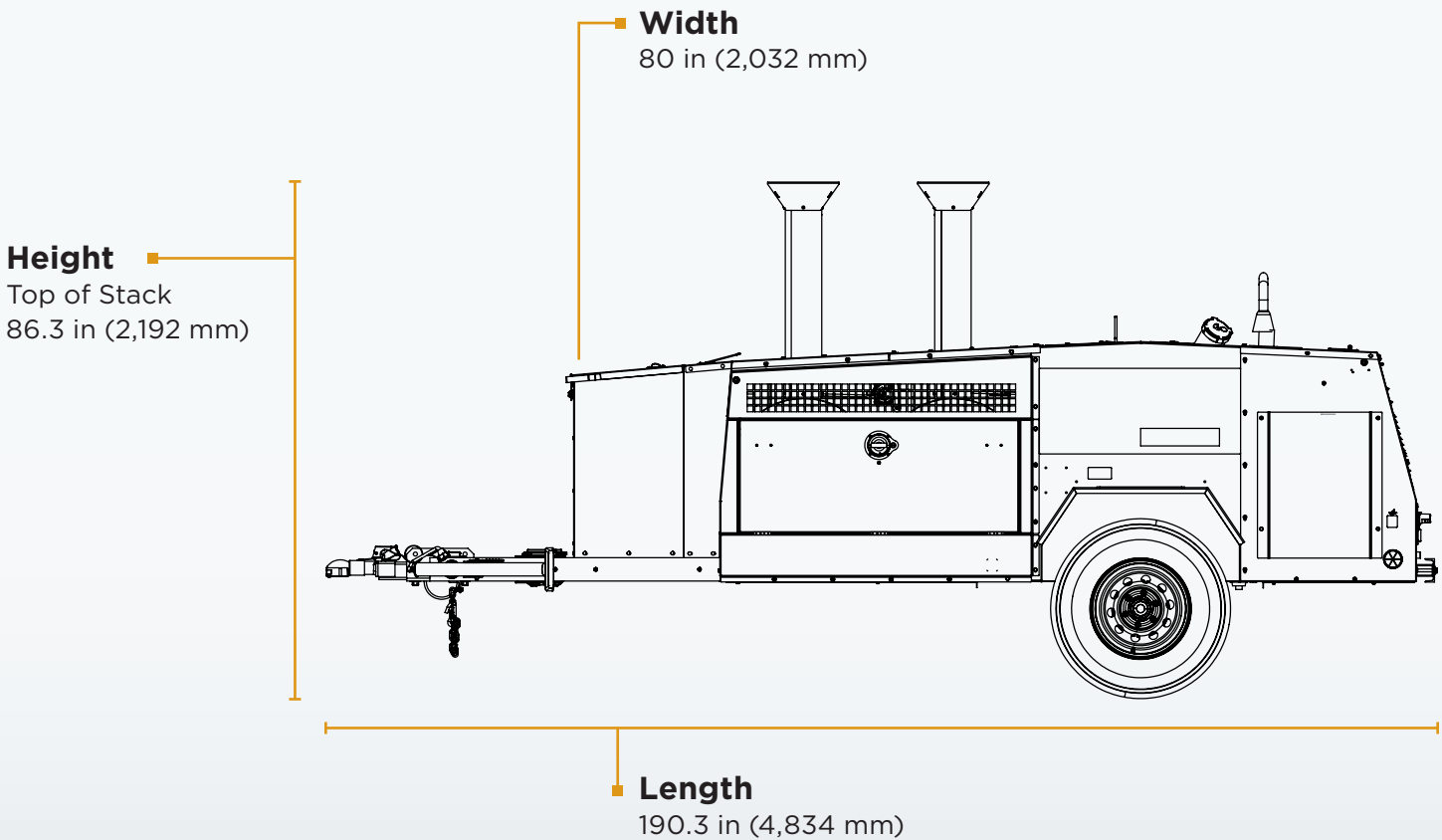

\* Prime generator electrical output per Allmand® testing. \*\* Based on one hour run test full fuel tank consumption. Allmand® has a policy of continuous product improvement and reserves the right to modify its specifications at any time and without prior notice. See operator's manual or [www.allmand.com](http://www.allmand.com) website for complete warranty details.

### Thermostat Package

- Remote Thermostat
- Lead extension

### 2 5/16" Bulldog Hitch

### Lockable Battery Disconnect

### Intake Air Shutdown

### Custom Paint

**Telematics** (Customer supplied - consult factory)



## COMPROMISE NOTHING.

At Allmand, our sole focus is providing jobsite support equipment to help your customers get the job done. Whenever they need it. Wherever they are. And whatever it takes. What's more, our genuine commitment to you — the highest standard of service and lowest total cost of ownership — is simply unmatched. Choose the equipment that comes with complete confidence that jobsite productivity won't go dark at 2 a.m. **Allmand. Above All.**