

R-265 CONCRETE MIXER

Turn your Pengo Planetary Auger Drive into a Concrete Mixer with this strong, versatile attachment.

The Pengo R-256 Concrete Mixer attachment allows you to mix, transport, and dump concrete more efficiently than a traditional stand-alone mixer.

The Mixers compact size and light weight design make it ideal for the Mini-Skid market and for limited-access or hard to reach areas.

The Mixer is perfect for applications such as driveways, sidewalks, finish work, and footings.

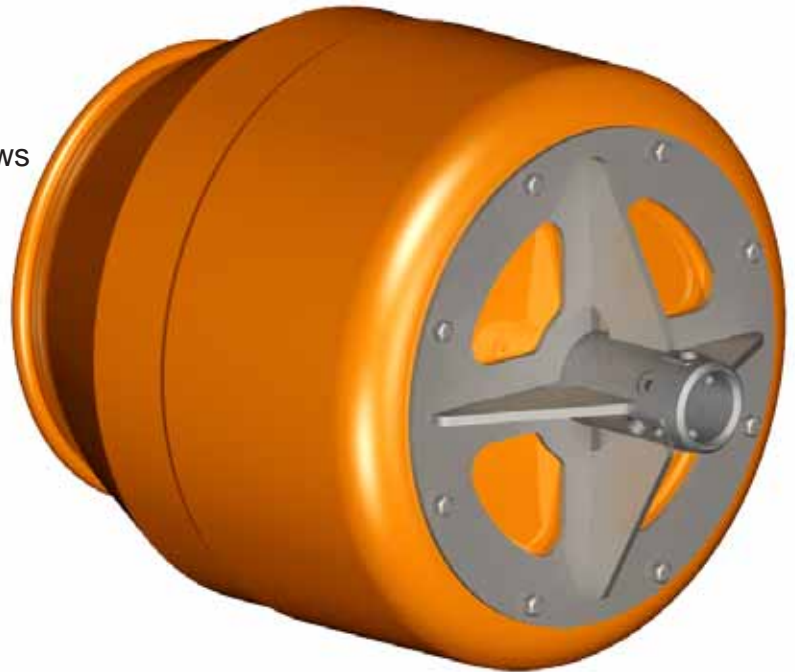

GENERAL SPECIFICATIONS

Drum Construction:	Welded 10ga. Steel
Max Drum Capacity:	4.8Cu/ft (.135 cu M)
Max Mix Capacity:	3.1 Cu/ft (.087 cu M)
Rec. Drum Speed:	20-25 RPM @ 12 gpm
Rec. Mixing Angle:	23 to 25 deg.
Rotation:	Bi-Directional
Unit Weight:	73 lbs (33.11 Kg)
Drum Dia.:	22.875" (581.02mm)
Height:	28.125" (714.37mm)

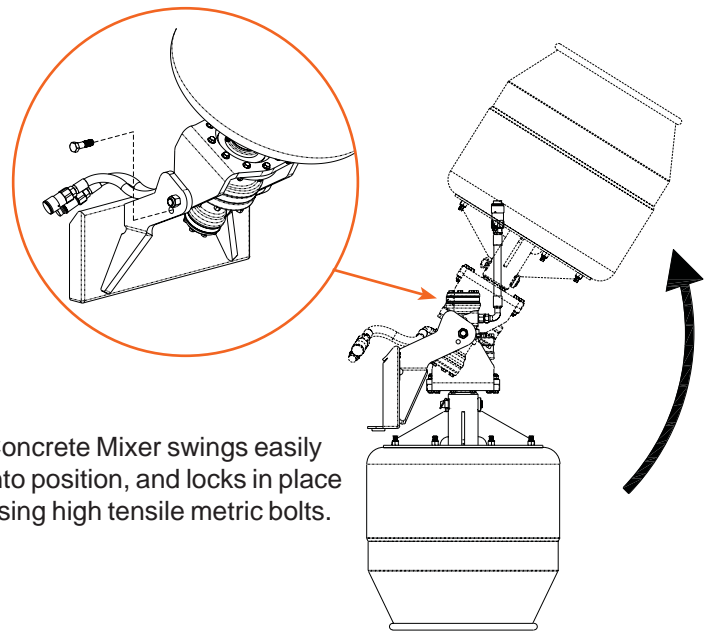

Concrete Mixer swings easily into position, and locks in place using high tensile metric bolts.

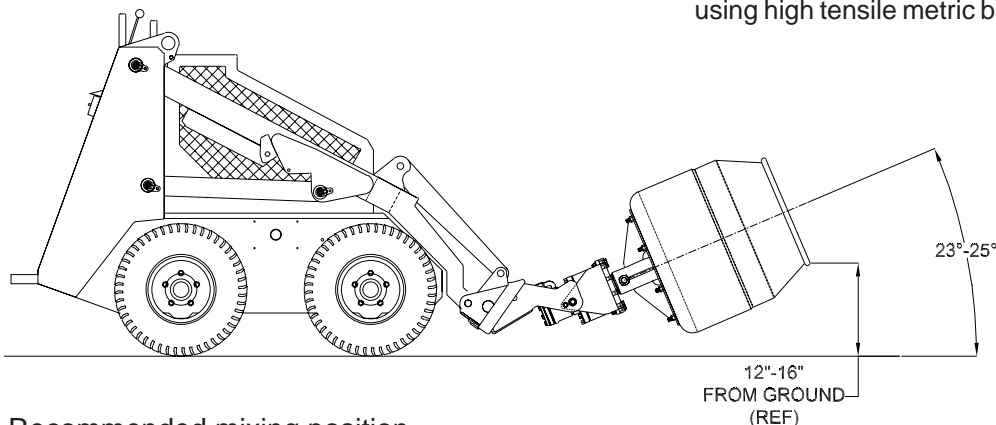

Recommended mixing position.



500 E. Highway 10, Laurens, IA 50554 - 800.599.0211
email: pengosales@paladinbrands.com www.pengoattachments.com