

SAFETY HOIST^{CO.}

OPERATOR'S MANUAL

EH-500 Electric Material Hoist

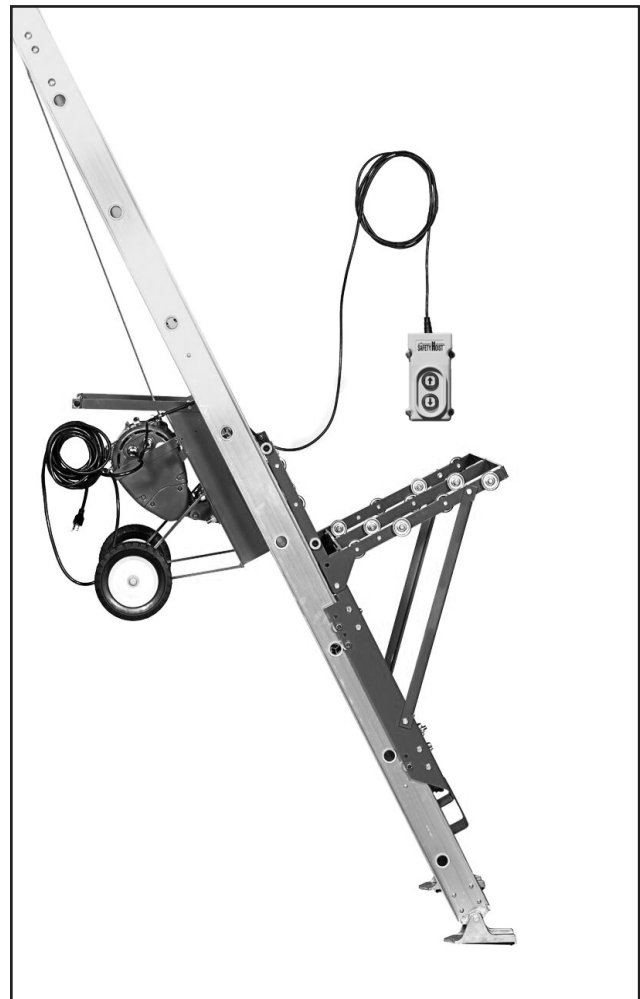

TABLE OF CONTENTS

GENERAL RECOMMENDATIONS & ADVICE	1
GENERAL SAFETY INSTRUCTIONS	2-3
SAFE OPERATION.....	4
LIST OF COMPONENTS.....	5
HEIGHT CHART.....	6
HOW TO ASSEMBLE YOUR HOIST	7-9
HOW TO OPERATE YOUR HOIST.....	10-11
PARTS LIST	12-20
MOTOR RECOMMENDATIONS.....	21
SAFETY HOIST COMPANY - LIMITED WARRANTY.....	22

GENERAL RECOMMENDATIONS AND ADVICE

EVERY TIME A SAFETY HOIST IS SET UP FOR OPERATION YOU MUST:

1. **NEVER** OPERATE HOIST IN WET WEATHER CONDITIONS!!!



2. THIS HOIST SHOULD **NEVER** BE USED TO TRANSPORT A PERSON FROM ONE ELEVATION TO ANOTHER!!

3. REMEMBER THAT THE HOIST TRACK IS **NOT** A LADDER! IF USED AS A LADDER INJURY MAY OCCUR.

4. Check condition of the electric hoist before connecting the pendant and the power cords.
5. Inspect winch drum and cable assembly for obvious damage or misalignment. Inspect winch drum to make sure that cable is wound smoothly with no crossovers. If there are any, use the pendant to run the hoist in reverse and pull off enough cable to eliminate the crossovers. Then, with a leather glove, carefully use the pendant to wind the cable back onto the drum to prevent cable kinking.
6. Inspect the pendant and power cables to make sure they are in good condition with no cuts or tears. Make sure no oil or mud etc. has gotten onto the connector assemblies which will cause the hoist to malfunction.
7. Test the brake system. Put one bundle of shingles (or about 70 to 100 pounds) on the platform. Only lift it two or three feet, and stop it, to make sure the brake system is working properly, and then lower the load. Once you are certain the brake system will hold, raise the load you are trying to lift up a few feet. Stop raising the load and wait a minute to make sure the load does not slip. This will verify that the brake system is working properly for the full load weight.

GENERAL SAFETY INSTRUCTIONS

The safety instructions and warnings in this section and throughout this manual must be read carefully before assembling or operating the hoist. These safety instructions and warnings are not substitutes for routine accident prevention measures which must also be implemented to eliminate potential risks and hazards. Failure to obey these safety warnings may result in injury to you or others, or damage to the hoist or other property.

A. UNPACKING YOUR HOIST

- When unpacking, carefully inspect for any damage that may have occurred during transit.
DO NOT ASSEMBLE OR USE THE HOIST IF ANY PART OR PARTS ARE DAMAGED!!
Return the damaged part or parts to place of purchase for replacement. Compare received parts to list of components on page 5. If they are not all there you should contact who you bought the hoist from, or call 877-99-HOIST.

B. SAFETY LABELS

- Observe all safety labels and instructions attached to the various parts of the hoist.

C. PROPER PARTS

- For your safety, use only attachments and accessories approved by the manufacturer for use with the hoist. Using substitute parts will void the warranty.

D. SAFETY CHECK

- Check assembled parts (splice plates, bolts, pulleys, hoist cable, etc.) for proper tightness and fit before using the hoist, and during frequent periods of use, be certain the equipment is in safe working condition. Before each use recheck for bolt tightness, and also recheck every 4 hours of operation.

E. TRANSPORTING

- To avoid damage, handle hoist component parts with care when transporting. Secure hoist to truck bed with cord rope or bungee cord. Damaged parts MAY make hoist not SAFE to operate. NOTE: Transporting uncovered hoist's in the rain may cause damage to the electric motor. Cover electrical components with a plastic sheet and inspect prior to use. See *page 7 - How To Assemble Your Hoist*.

F. BRACING YOUR HOIST

- Never place or operate the hoist on a slippery surface and make certain the base section is properly leveled and secured at the base to prevent slippage or unexpected movement. Make sure the hoist is braced against a building or solid surface at the correct angle as described herein.

GENERAL SAFETY INSTRUCTIONS

The safety instructions and warnings in this section and throughout this manual must be read carefully before assembling or operating the hoist. These safety instructions and warnings are not substitutes for routine accident prevention measures which must also be implemented to eliminate potential risks and hazards. Failure to obey these safety warnings may result in injury to you or others, or damage to the hoist or other property.

G. HOUSEKEEPING

- Clear the area around the base of the hoist to avoid slipping, tripping, or falling against the hoist. Place the cords in a way that they will NOT be a tripping hazard.

H. SECURING YOUR HOIST

- Secure track to the roof with a rope. Tie the rope to a rung or the peak and then secure other end of rope to the building. Do not tie to the rail because the rope will interfere with the travel of the carriage.

SAFE OPERATION

HAZARD! - DO NOT PLACE OR USE THIS MATERIAL HOIST IN AN AREA WHERE IT COULD COME IN CONTACT WITH OVERHEAD WIRES OR ELECTRICAL WIRING CIRCUITS OR ANY OTHER HAZARDOUS OBSTRUCTION.

NEVER OPERATE HOIST IN WET WEATHER CONDITIONS!!!



A. PROPER INSTRUCTIONS

- DO NOT ALLOW ANYONE TO OPERATE THE HOIST WHO HAS NOT BEEN PROPERLY AND THOROUGHLY TRAINED IN ITS OPERATION AND USE. BEFORE OPERATING, THE INSTRUCTIONAL YOUTUBE VIDEO ON PAGE 11 SHOULD BE VIEWED, OR YOU CAN FIND THE INSTRUCTIONAL VIDEO ON OUR WEBSITE -- www.safetyhoistcompany.com

B. WARNING:

- USE THE HOIST FOR LIFTING MATERIALS ONLY.
THE HOIST SHOULD NEVER BE USED TO TRANSPORT A PERSON FROM ONE ELEVATION TO ANOTHER!!!!

C. MAXIMUM CAPACITY

- **THE MAXIMUM CAPACITY OF THE HOIST IS 500 POUNDS. DO NOT OVERLOAD!!**

D. WARNING

- Keep hands, feet, other body parts and clothing away from the track and moving or rotating parts of the hoist when operating the hoist.

E. MOLTEN SUBSTANCES

- Do NOT use the hoist to lift buckets of hot asphalt or any other hot or liquid substance, unless contents are in a closed and sealed container.

F. SUPERVISION

- ALWAYS unplug the electric hoist from the power supply when you leave the vicinity of the hoist.

LIST OF COMPONENTS

1. ONE (1) - Power Unit (hoist bolted on base) (includes a storage compartment)
2. ONE (1) -Power cord with screw connection
3. ONE (1) - Pendant with screw connection
4. ONE (1) - EH Peak
5. ONE (1) - Carriage Trolley
6. ONE (1) - Deck & Flap assembly
7. TWO (2) - Carriage support arms
8. ONE (1) - Set of plywood carriers
9. ONE (1) - 4 ft. track section with splice plates attached
10. ONE (1) - 8 ft. base track section with feet attached
11. TWO (2) - 8 ft. track sections with splice plates attached
12. ONE (1) - Assembly hardware bag

HOIST HEIGHT CHART

HEIGHT TO BEARING POINT "A"	MAXIMUM HORIZONTAL DISTANCE "B"	HOIST LENGTH "C"
10 ft.	2 ft. 6 in.	12 ft.
14 ft.	3 ft. 6 in.	16 ft.
18 ft.	4 ft. 6 in.	20 ft.
22 ft.	5 ft. 6 in.	24 ft.
26 ft.	6 ft. 6 in.	28 ft.
30 ft.	7 ft. 6 in.	32 ft.
34 ft.	8 ft. 6 in.	36 ft.
38 ft.	9 ft. 6 in.	40 ft.

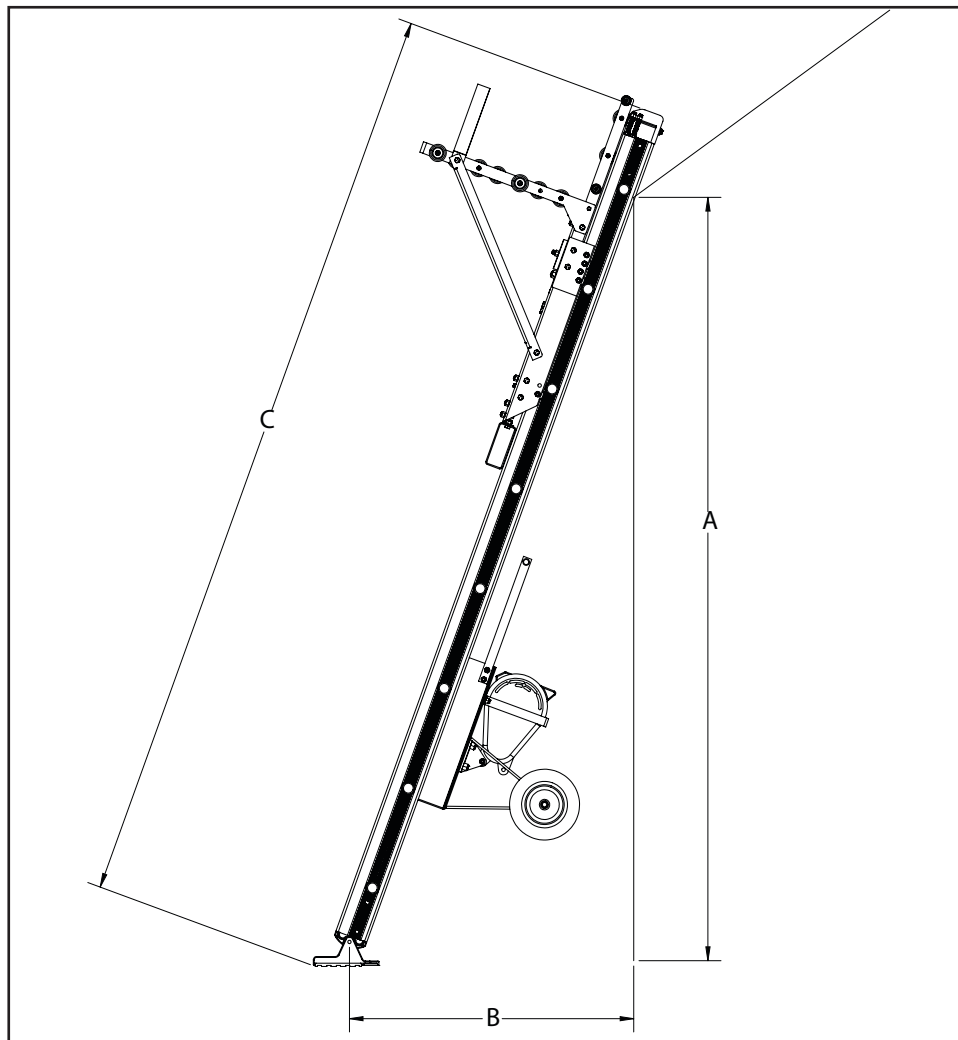

HOW TO ASSEMBLE YOUR HOIST

1. **Unpack ALL parts of the hoist and lay them flat on the ground**

See page 5 for a list of included parts and materials. If any parts are missing, call 877-99-HOIST.

2. **Lay the base track section on the ground with the rung short-side facing down.**

NOTE: That the rungs are not centered on the rail.
SEE FIGURE 1

3. **Track sections are attached using the splice plates on the INSIDE of the track section.**

Attach them with $3/8'' \times 3/4''$ carriage bolts and lock nuts.
SEE FIGURE 2

4. **Lay the trolley on the ground & bolt the carriage support arms w/ $3/8-16 \times 1.25$ bolts and nuts.**

5. **Attach the deck & flap to the trolley & support arms with $3/8-16 \times 1.25$ bolts and nuts.**

SEE FIGURE 3

6. **Slide the carriage onto the track section from the TOP of the track (side opposite of the feet).**

Do this with the flat surface of the carriage facing away from the base section.

SEE FIGURE 4



FIGURE 2

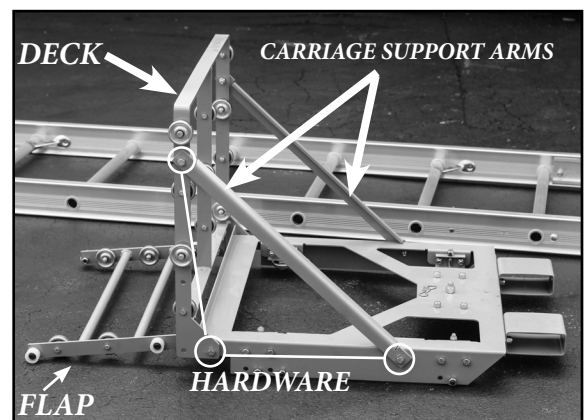

FIGURE 3



FIGURE 4

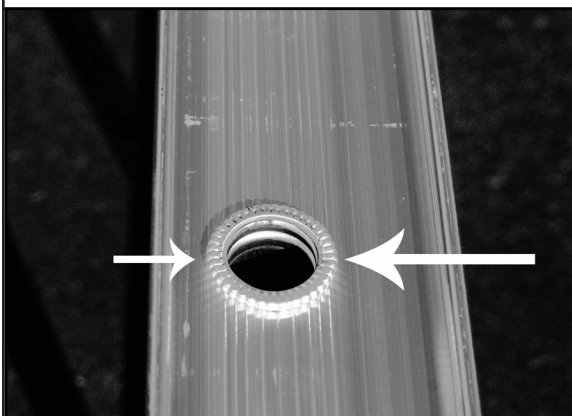

FIGURE 1

HOW TO ASSEMBLE YOUR HOIST *Continued*

7. Slide the carriage along the track to the base section. Make sure carriage slides smoothly on the track.

If not remove carriage and reinstall making sure carriage wheels roll on track flanges.

8. Slide the peak assembly (EH-B) onto the end of the track.

Secure it with two (2) 3/8" x 3/4" carriage bolts and lock nuts. NOTE: The square holes are off-set, if holes do not line-up - flip around. SEE FIGURE 5

9. Turn the hoist track w/ the carriage assembly attached on its side.

10. Remove power cord and pendant cord from the power unit storage compartment and attach them to hoist with quick connect fittings.

Attach strain relief hooks on cords to eyelits on hoist. SEE FIGURE 6

11. Plug the power unit into a 110v 15-amp GFCI* electrical supply

*Ground-Fault Circuit Interrupter

12. Unwind enough cable from the electric winch to go through pulley at the peak and back down the other side of the track to the carriage by pressing the DOWN (D) button on the pendant.

SEE FIGURE 7

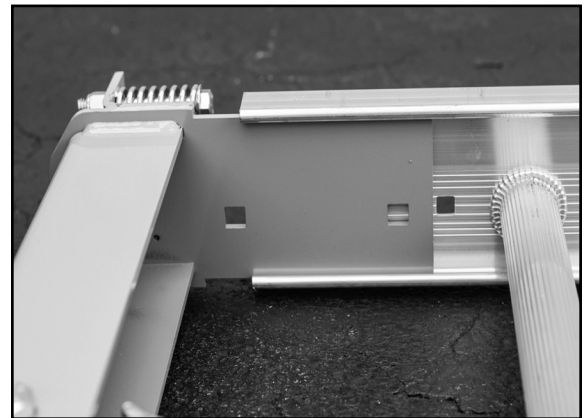

FIGURE 5

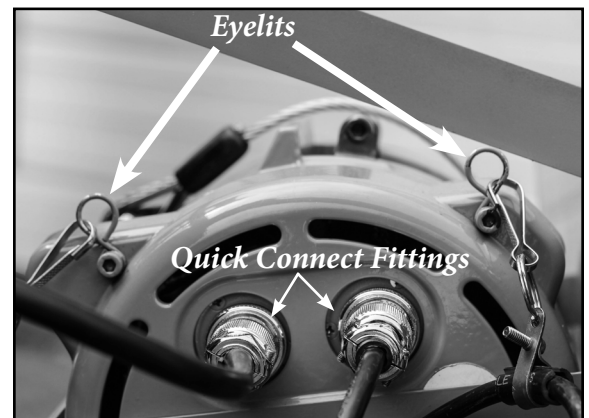

FIGURE 6

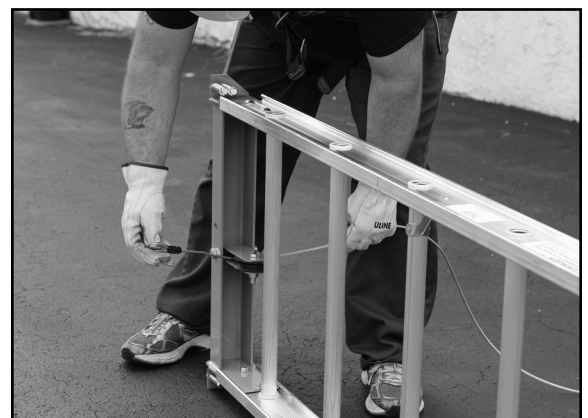

FIGURE 7

HOW TO ASSEMBLE YOUR HOIST *Continued*

13. Attach the thimble on the cable to the back of the carriage using the supplied clevis pin.

SEE FIGURE 8

14. You are now ready to lift the hoist into place.

WARNING: When setting up your hoist please take note of all overhead obstructions and/or electrical wires. Select a location that is free of traffic and pedestrians.

15. Lay the assembled hoist alongside the wall where the hoist is to be used.

16. Place hoist against building at the correct angle.

See chart on page 6 to determine the correct angle of incline.

17. Attach lifting handle to the power pack w/ hardware included in hardware bag and wheel over to track section.

SEE FIGURE 9

18. Move the black stop-collars from the 5th rung to the 4th rung using a 3/16 Allen Wrench.

By placing these stop-collars on both sides of the power pack on the 4th rung, it will secure your hoist in place to eliminate movement.

SEE FIGURE 10

19. Attach power pack to the 4th rung up from the bottom of the track and pin it to the 3rd rung up from the bottom of the track.

SEE FIGURE 10

20. Using the pendant, press the UP button to take the slack out of the cable.

21. You are now ready to operate the hoist.

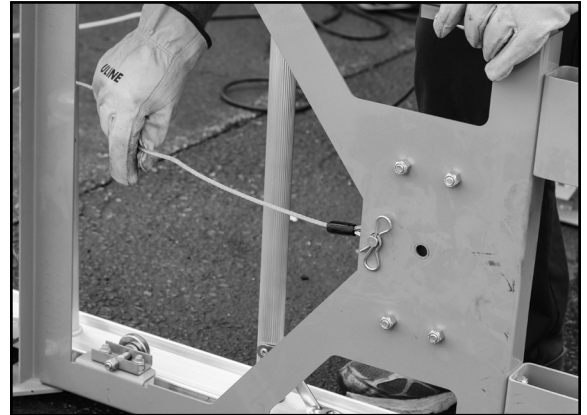

FIGURE 8

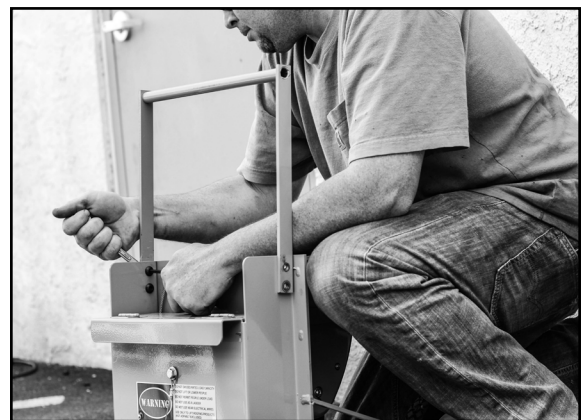

FIGURE 9

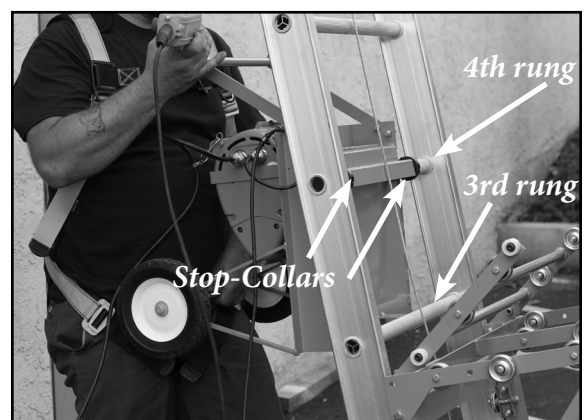

FIGURE 10

HOW TO OPERATE YOUR HOIST

THE OPERATOR OF THE HOIST MUST WEAR ALL OF THE NECESSARY PROTECTIVE GEAR WHICH SHOULD INCLUDE FOOT, HAND, EYE AND HEAD PROTECTION. KEEP HANDS AWAY FROM ALL MOVING PARTS AT ALL TIMES.

1. The operator should run a TRIAL RUN at this time by pressing UP button on the pendant to raise the carriage. To bring carriage back down, press the DOWN button.

Test should be done while the carriage assembly is loaded with 70 to 100 lbs. and should be run in accordance with these instructions to check for proper operation. SEE FIGURE 11 & 12

2. During the TRIAL RUN, be sure to inspect the winch drum assembly.

Cable on winch drum must be smooth and in neat coils with no cable crossing. It should also be tight on the winch drum. If cable has crossovers or is loose, using the pendant, run the winch in reverse and pull off enough cable to fix crossovers or tighten loose cable. Rewind cable on winch drum neatly and tightly, with coils laying side by side.

3. Run one last TRIAL w/ a full load. Make sure the cable is tight and is properly attached to the carriage, press the UP button on the pendant. Do this 2 or 3 times.

4. If at any time the brake does NOT hold the carriage in place, call 877-99-HOIST.

5. **DO NOT EXCEED THE HOIST WEIGHT LIMIT! THE WEIGHT CAPACITY OF THIS HOIST IS 500 LBS!!!!!!!**



FIGURE 11



FIGURE 12

HOW TO OPERATE YOUR HOIST *Continued*

6. Press the UP (U) button on the pendant to start the winch and launch carriage into its upwards travel.

The button must be pressed the entire time it takes to reach the unload position at the peak. When the carriage unloading flap rotates into the unload position, release the UP button to stop the winch.

SEE FIGURE 13.

7. To bring carriage back down, simply press the DOWN (D) button on the pendant continuously until the carriage reaches the bottom.

8. If you choose to use the hoist to lower material to the ground, load material onto the carriage & hold the DOWN (D) button continuously until the carriage reaches the bottom.

Make sure the material is secure before descent.

9. After job is complete, disconnect the pendant and the power cords and store them in the storage compartment provided on the power unit.

This is also a convenient place to store your manual.
SEE FIGURE 14.



FIGURE 13



FIGURE 14

We recommend that you view the instructional videos on our YouTube page for your Safety Hoist™ model.



@Safety Hoist Company



Scan the QR Code to go directly to our YouTube channel!

BASE ASSEMBLY - NG-D-E100

ITEM NO.	PART NUMBER	DESCRIPTION	QTY.
1	NG-D-E101	BASE WELDMENT	1
2	HD-D403	WHEEL	2
3	.625 CAP NUT	.625 CAP NUT	2
4	NG-D-E106	BRACKET, HOIST	2
5	ELECTRIC HOIST	ELECTRIC HOIST	1
6	NG-D-E121	BRACKET, HOIST SUPPORT	1
7	NG-D-E102	HANDLE	1
8	NG-D-E125	ANCHOR PIN LANYARD	1
9	.375-16 X 6.0 LG HHCS	3/8-16 X 6.0 LG HHCS	1
10	.375-16 X 1.0 LG BHCS	3/8-16 X 1.0 LG BHCS	4
11	.375-16 LN	3/8-16 LOCKNUT	8
12	0.5-13 1.0 LG HHCS	1/2-13 X 1.0 LG HHCS	4
13	0.5-13 LN	1/2-13 LOCKNUT	4
14	.375-16 X .75 LG HHCS	3/8-16 X .75 LG HHCS	3
15	EH-D136	SERIAL NO. PLATE	1
16	LABEL-WARNING	WARNING LABEL	1
17	.375 FW	3/8 FLAT WASHER	1
18	POP RIVET 0.125 X 0.187 LG	POP RIVET 0.125 X 0.3125 LG	4

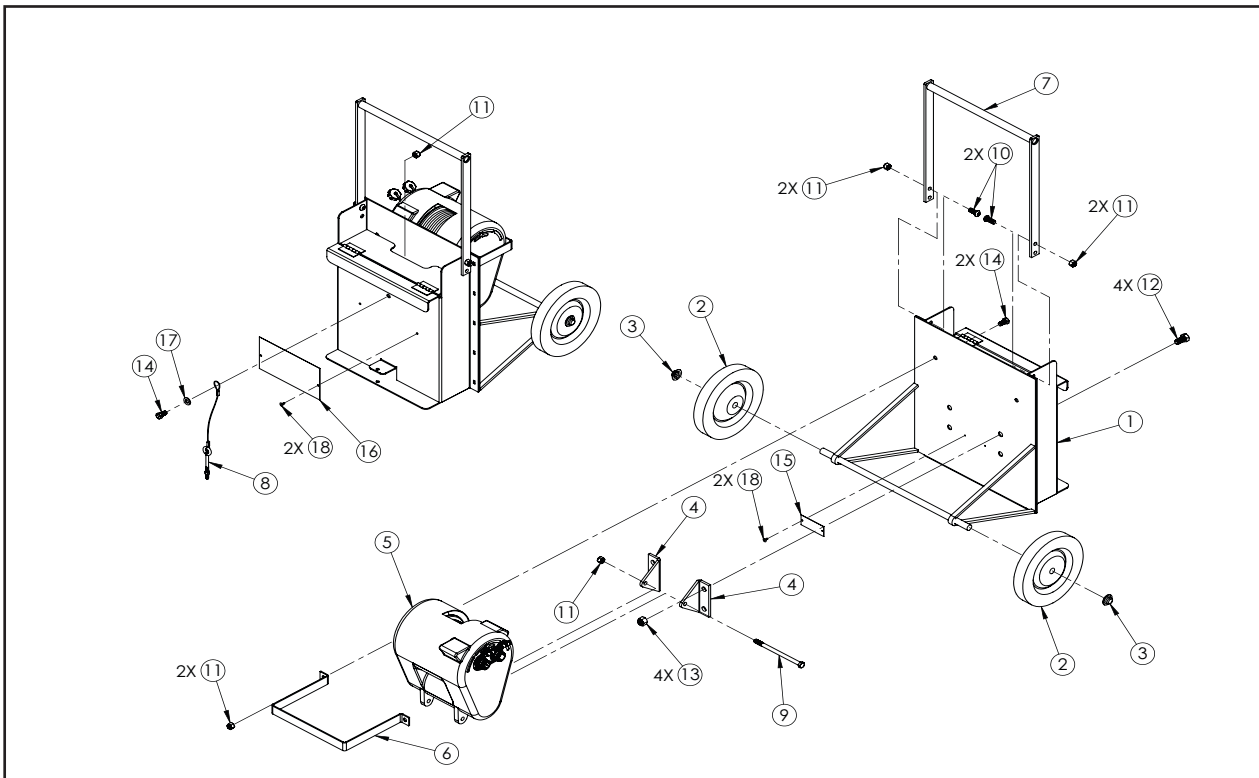

CARRIAGE ASSEMBLY COMPLETE - EH500-C

ITEM NO.	PART NUMBER	DESCRIPTION	QTY.
1	EH500-C054	CARRIAGE TROLLEY	1
2	HD-C053	CARRIAGE DECK	1
3	HD-C052	CARRIAGE FLAP	1
4	HD-C049	BEARING .375 ID X .375 LG	2
5	HD-C040	CARRIAGE SUPPORT ARM	2
6	.375-16 X 1.25 LG HHCS	.375-16 X 1.25 LG HHCS	8
7	.375-16 LN	3/8-16 LOCKNUT	8
8	HD-400-PLYWOOD ASSY L	PLYWOOD CARRIER LH	1
9	HD-400-PLYWOOD ASSY R	PLYWOOD CARRIER RH	1

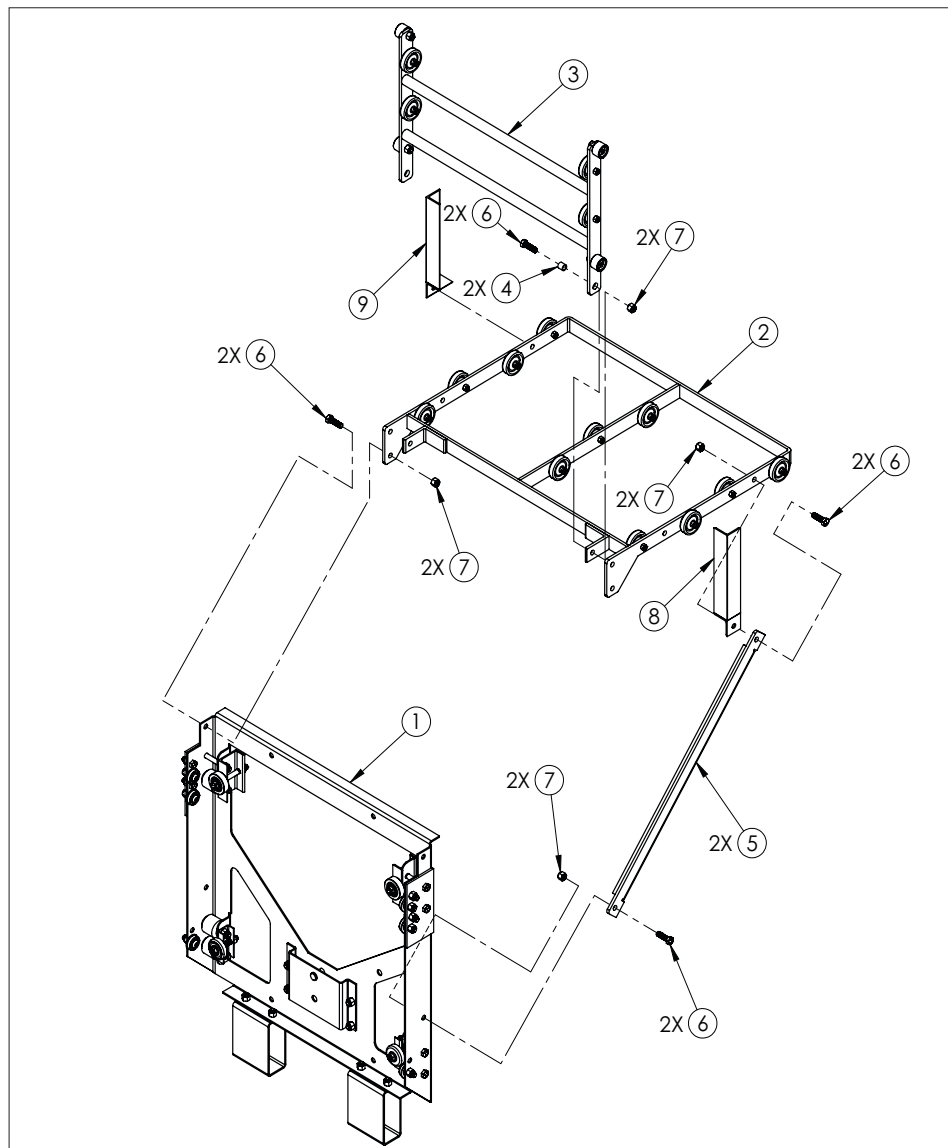

CARRIAGE DECK - HD-C053

ITEM NO.	PART NUMBER	DESCRIPTION	QTY.
1	HD-C031-WELD-ASSY	CARRIAGE DECK WELDMENT ASSY	1
2	SKATE	CARRIAGE SKATE WHEEL	11
3	0.25-20 X 1.5 LG HHCS	1/4-20 X 1.5 LG HHCS	11
4	.25-20 LN	1/4-20 LOCKNUT	11

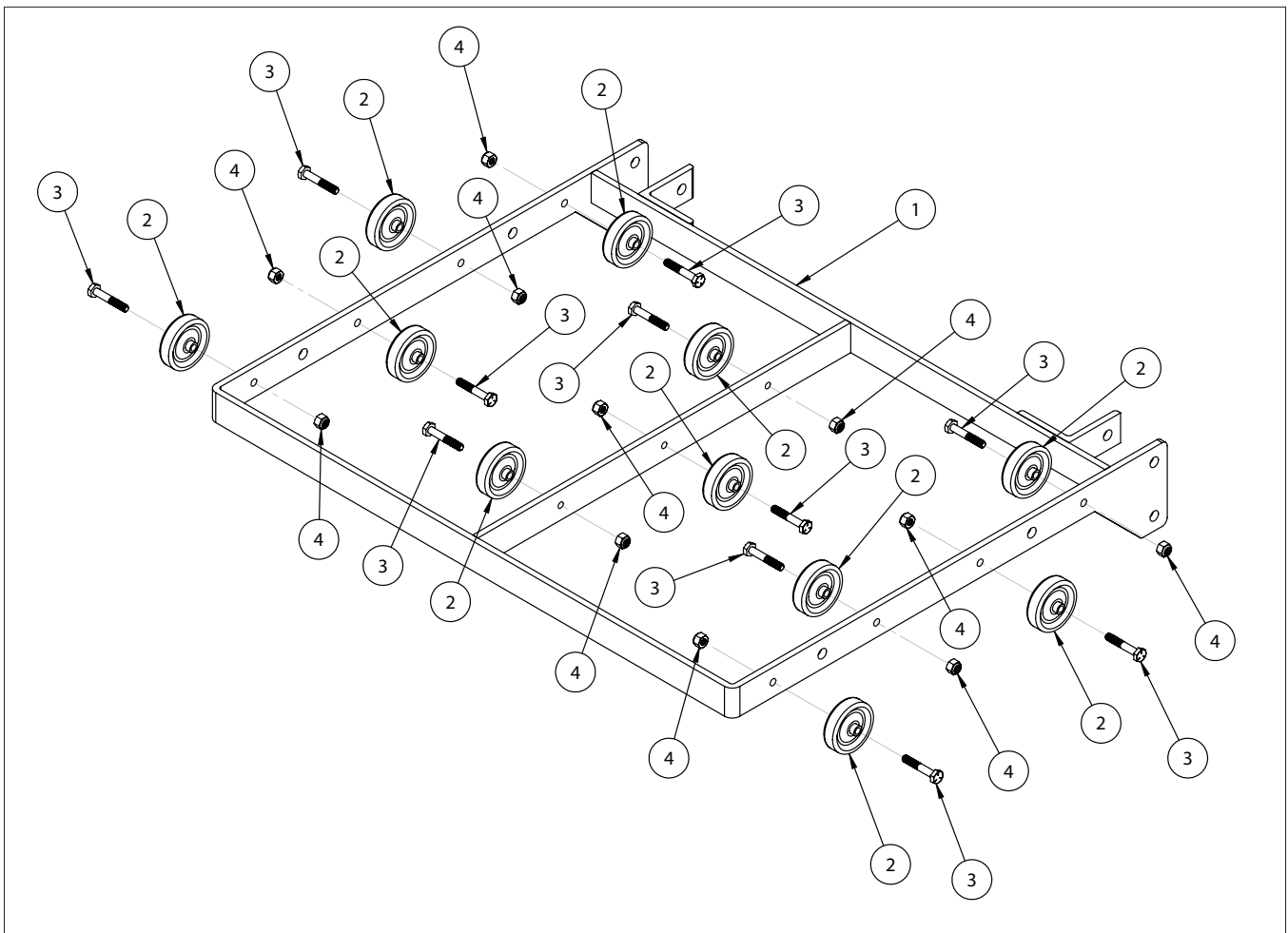

CARRIAGE FLAP - HD-C052

ITEM NO.	PART NUMBER	DESCRIPTION	QTY.
1	HD-C032-WELDMENT	FLAP WELDMENT	1
2	SKATE	CARRIAGE SKATE WHEEL	4
3	0.25-20 X 1.5 LG HHCS	1/4-20 X 1.5 LG HHCS	4
4	.25-20 LN	1/4-20 LOCKNUT	4
5	HD-C035	FLAP WHEEL 1.125 PLASTIC	4
6	HD-C050	BUSHING	4
7	.375-16 X 1.25 LG BHCS	3/8-16 X 1.25 LG BHCS	4
8	.375-16 LN	3/8-16 LOCKNUT	4

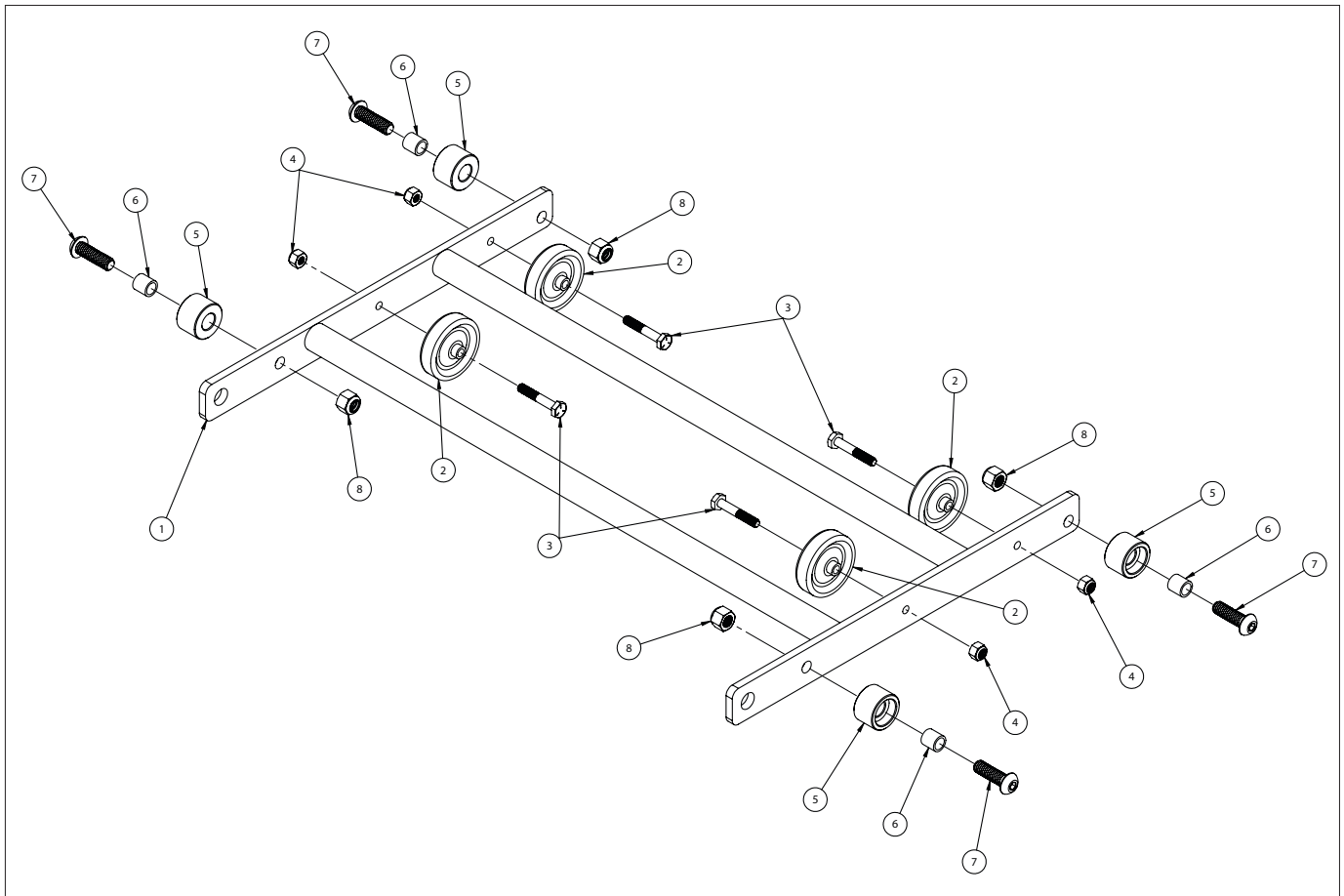

CARRIAGE TROLLEY - EH500-CO54 *(page 1 of 2)*

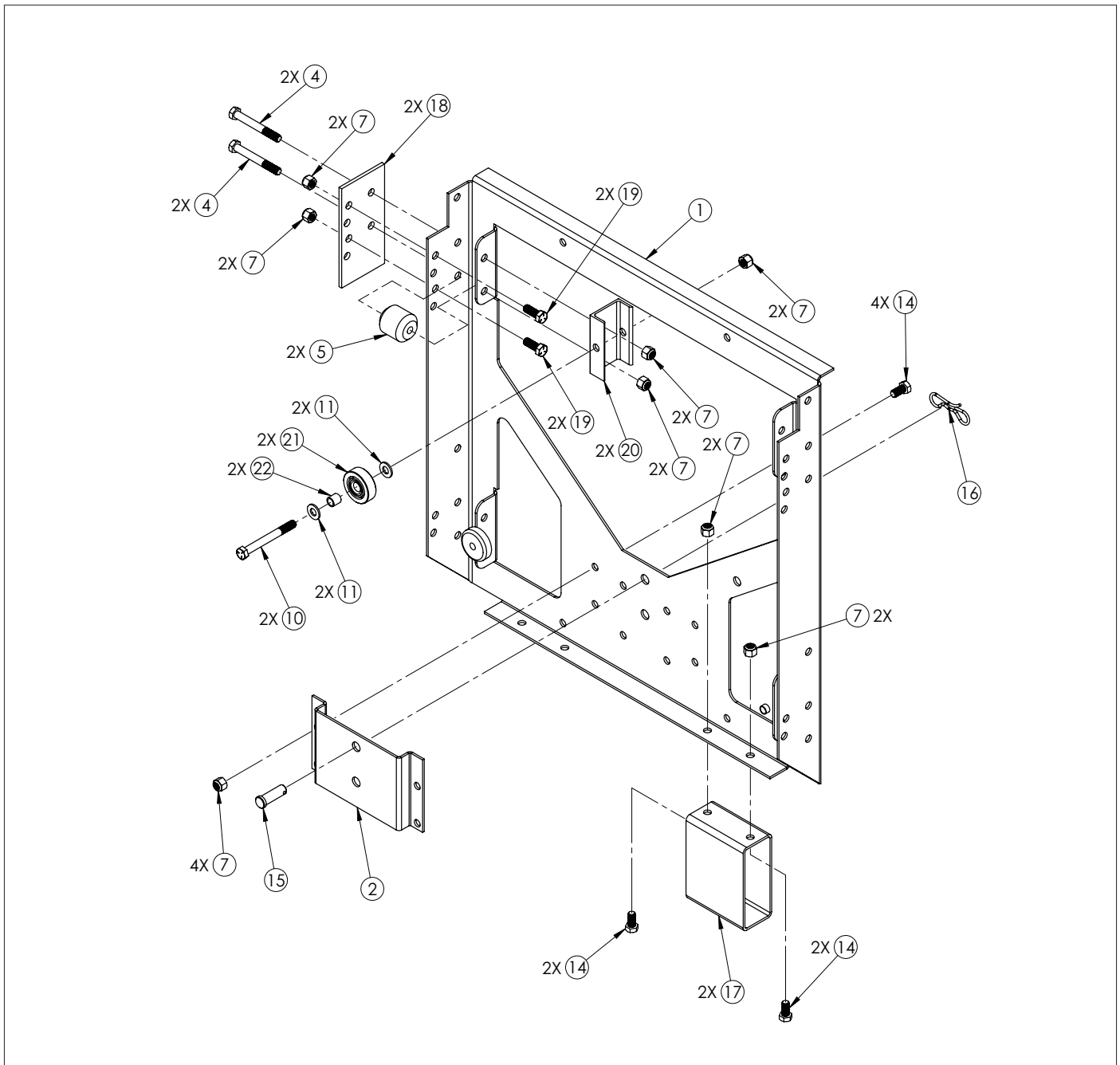

SEE PAGE 17 FOR CARRIAGE TROLLEY PART NUMBERS & DESCRIPTIONS

CARRIAGE TROLLEY - EH500-CO54 *(page 2 of 2)*

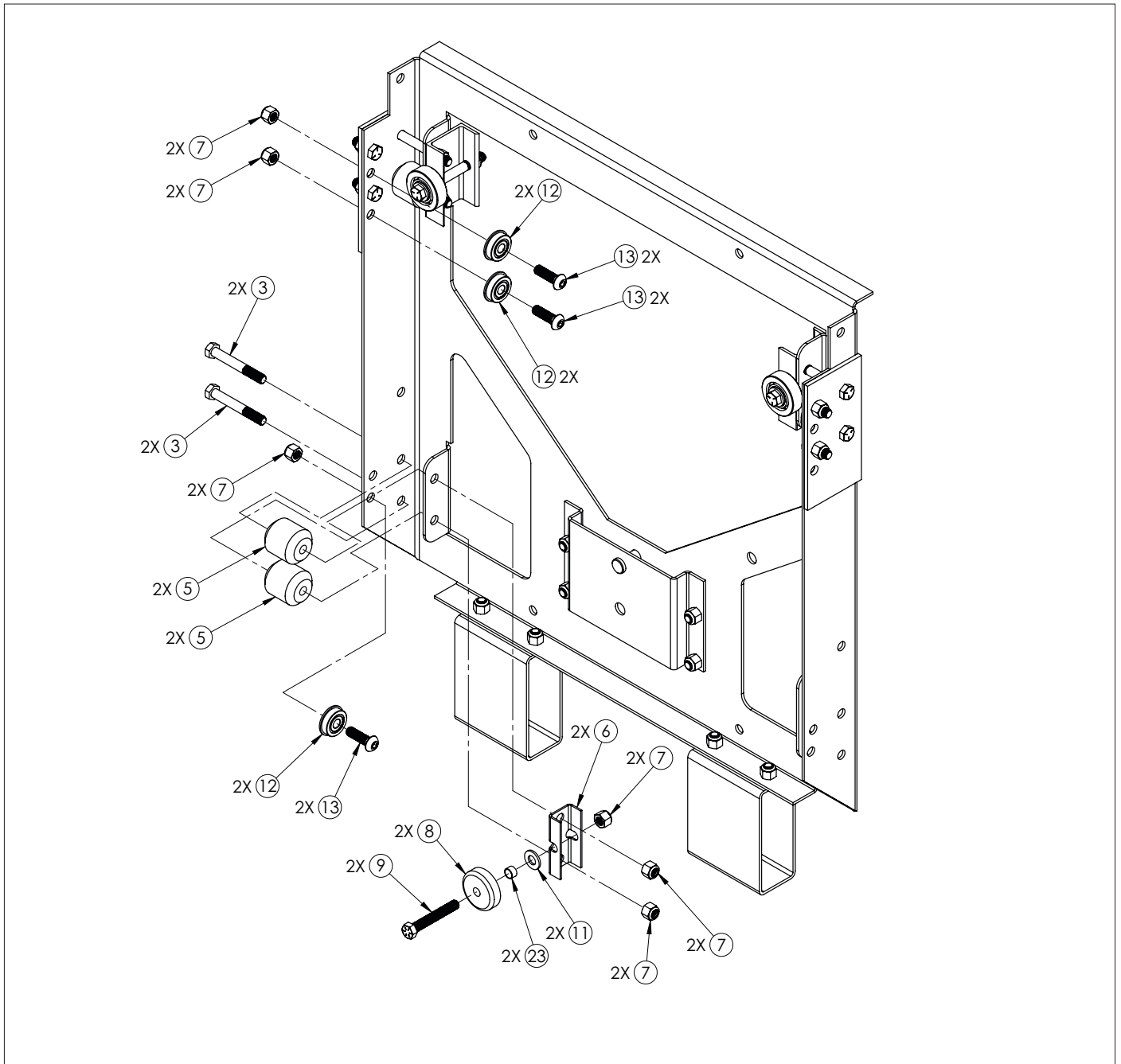

SEE NEXT PAGE FOR CARRIAGE TROLLEY PART NUMBERS & DESCRIPTIONS

CARRIAGE TROLLEY - EH-C054 *Continued*

ITEM NO.	PART NUMBER	DESCRIPTION	QTY.
1	HD-C030	TROLLEY FRAME	1
2	HD-C033	CARRIAGE PULLEY BRACKET	1
3	.375-16 X 2.75 LG HHCS	3/8-16 X 2 3/4 LG HHCS	4
4	.375-16 X 3.00 LG HHCS	3/8-16 X 3.00 LG HHCS	4
5	HD-C036	CARRIAGE WHEEL 2.0 PLASTIC	6
6	HD-C043	GUIDE WHEEL BRACKET	2
7	.375-16 LN	3/8-16 LOCKNUT	30
8	HD-C045	TROLLEY GUIDE WHEEL	2
9	.375-16 X 2.5 LG HHCS	3/8-16 X 2 1/2 LG HHCS	2
10	.375-16 X 3.5 LG HHCS	3/8-16 X 3 1/2 LG HHCS	2
11	.375 FW	3/8 FLAT WASHER	6
12	HD-C044	SMALL TROLLEY WHEEL	6
13	.375-16 X 1.25 LG BHCS	3/8-16 X 1 1/4 LG BHCS	6
14	.375-16 X .75 LG HHCS	3/8-16 X 3/4 LG HHCS	8
15	HD-C039	CLEVIS PIN	1
16	HD-C038	COTTER PIN, BOW TIE	1
17	HD-C041	BUMPER	2
18	EB-401	SIDE PLATE	2
19	.375-16 X 1.0 LG HHCS	3/8-16 X 1.0 LG HHCS	4
20	HD-C043-U	GUIDE WHEEL TRUCK	2
21	HD-C045-U	GUIDE WHEEL UPPER	2
22	HD-C050	BUSHING	2
23	HD-C051	GUIDE WHEEL BUSHING	2

PEAK ASSEMBLY - EH-500-B

ITEM NO.	PART NUMBER	DESCRIPTION	QTY.
1	HD-B010	PEAK WELDMENT	1
2	HD-B011	PULLEY SUPPORT	1
3	HD-B012	PULLEY	1
4	0.5-13 X 3.75 LG HHCS	1/2-13 X 3.75 LG HHCS	1
5	0.5-13 LN	1/2-13 LOCKNUT	2
6	0.5-13 X 2.0 LG HHCS	1/2-13 X 2.0 LG HHCS	1
7	HD-B014	COMPRESSION SPRING	4
8	.375-16 X 2.5 LG HHCS	3/8-16 X 2.5 LG HHCS	4
9	.375-16 LN	3/8-16 LOCKNUT	4

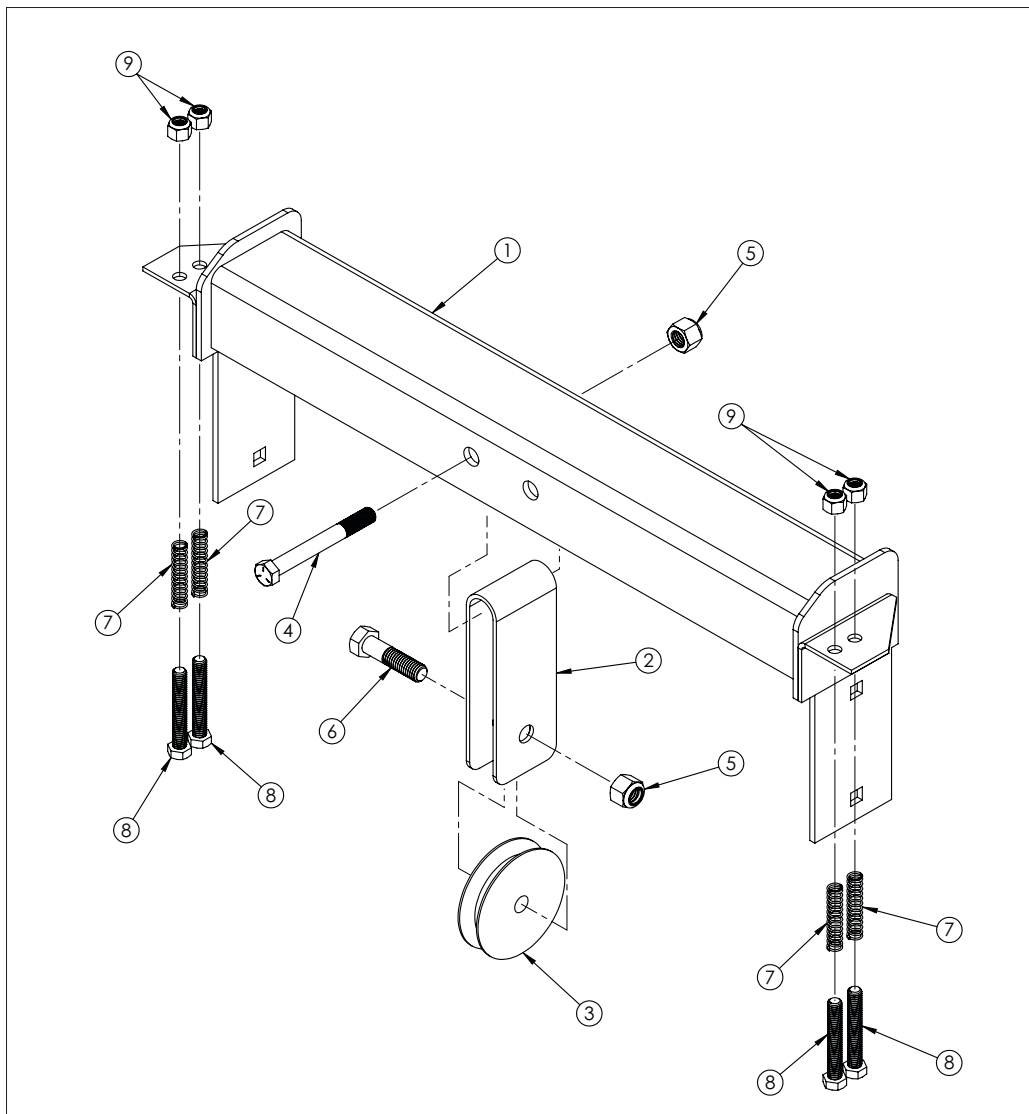

EH-500 CAPACITY MATERIAL HOIST & ACCESSORIES

PART #	DESCRIPTION
EH-500	Material hoist, 28' complete
HD-400SB	Support brace
HD-RAMP	Unloading ramp
SB-ASSY-HD	Flat Panel/Solar Panel Cradle
HD-A002	8' Track section w/ splice plates (17.25" x 3.0" x 96")

EH-500 MATERIAL HOIST AVAILABLE PARTS LIST

PART #	DESCRIPTION
HD-A006	8 ft. Base track section
HD-A002	8' Track section w/ splice plates (17.25" x 3.0" x 96")
HD-A003	4' Track section w/ splice plates (17.25" x 3.0" x 48" long)
HD-A007	Splice plates (2) w/ nuts & bolts
EH-500-B	Peak assembly
EH-500-C	Carriage assembly complete
HD-C052	Carriage flap w/ skate wheels
NG-D-E-100-PK	Power weldment
HD-D403-PK	Wheels
NG-D-E-121-PK	Top bracket
NG-D-E106-PK	Anchor
HD-D434-PK	Handle
E-HOIST	Motor
HD-400SB	Support brace
HD-RAMP	Unloading ramp
SB-ASSY-HD	Flat Panel/Solar Panel Cradle
HD-C035-PK	Flap wheels - Nylon - 4/pk.
HD-C036-PK	Carriage wheels - Nylon - 6/pk.
HD-C037-PK	Skate wheel - set of 11
HD-C045-PK	Carriage stabilizer bracket w/ wheel - 4/pk.
HD-C044-PK	Metal trolley wheels - 6/pk.

MOTOR RECOMMENDATIONS

SEE SEPARATE OPERATION MAUAL
- ELECTRIC WIRE ROPE HOIST -
ACCOMPANYING THIS MANUAL.

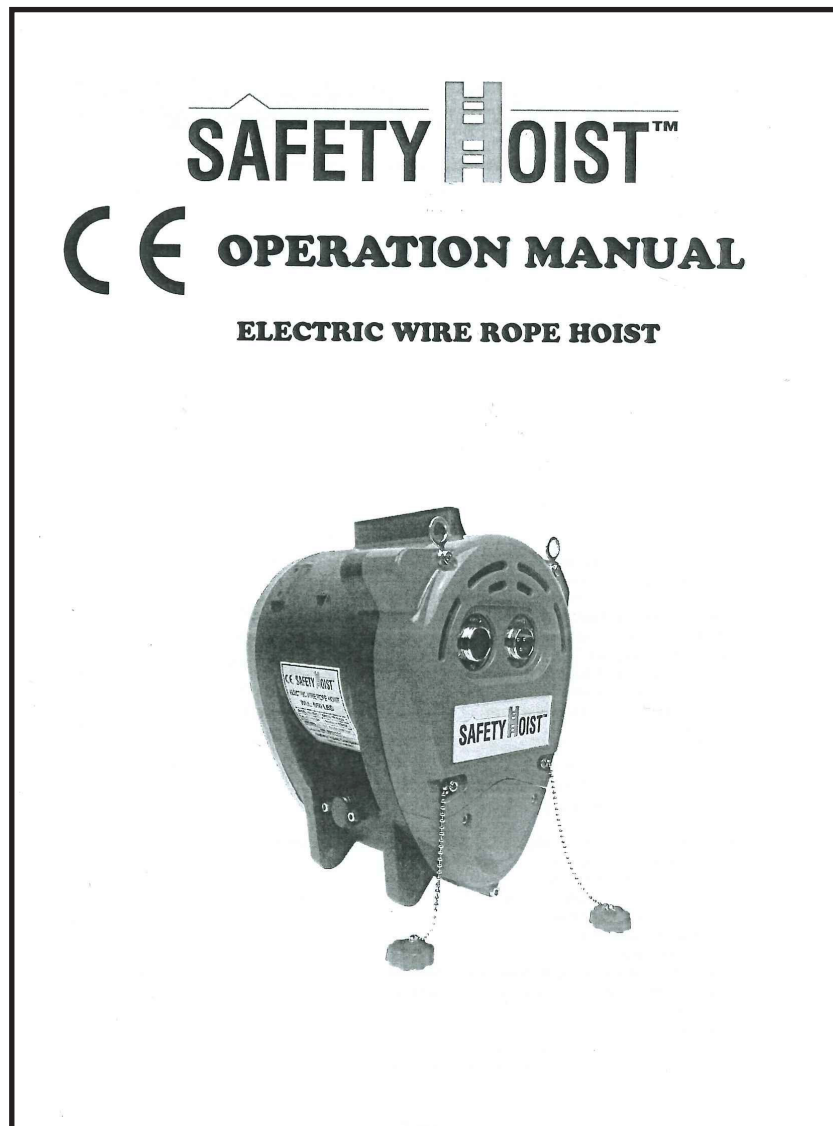

SAFETY HOIST COMPANY - LIMITED WARRANTY

REPLACES ALL DATED OR UNDATED LIMITED WARRANTIES DATED BEFORE JUNE 25, 2017.

Safety Hoist Company will at its option, repair or replace any part or parts of the Safety Hoist material hoist that are defective in material or workmanship with the exclusion of the motor/engine which maintain a separate warranty provided by the manufacturer of the motor/engine. The terms of the warranty of the motor/engine are provided on the previous page.

The limited warranty on all parts except the motor/engine is in effect for 1 year from the date of purchase.

Safety Hoist Company reserves the right to inspect the equipment for misuse, abuse or failure to maintain the equipment properly.

Safety Hoist Company will make reasonable efforts to repair or replace defective equipment in a timely manner, but assumes no liability or expenses incurred for the time lost as a result of the repair or replacement.

The defective unit or parts should be returned to the dealer where the unit was purchased or contact Safety Hoist Company at 877-994-6478.

There is no other express warranty implied. Warranties including those of merchantability and fitness for a particular purpose are limited to one year from purchase or to the extent permitted by law. Some states do not allow limitation on how long an implied warranty lasts, so the above limitation may not apply to you. This is the exclusive remedy and liability for incidental and consequential damages under any and all warranties are excluded to the extent permitted by law. Some states do not allow the exclusion or limitation of incidental or consequential damages, so the above limitation may not apply to you. This warranty gives you specific legal rights and you may also have other rights which vary from state to state.

Safety Hoist Company shall be relieved of its performance of the duties under this warranty if any damage has been caused to the product as a result of misuse, abuse, failure to maintain the equipment or Act of God.