





Parts Drawing - ES 1000

-  Torque to 17-23 ft-lbs
(23.0-31.1 N·m)
-  Torque to 190-210 in-lbs
(21.4-23.7 N·m)
-  Torque to 18-22 in-lbs
(2.0-2.4 N·m)
-  Torque to 23-27 ft-lbs
(31.1-36.6 N·m)
-  Torque to 45-55 ft-lbs
(61.0-74.5 N·m)

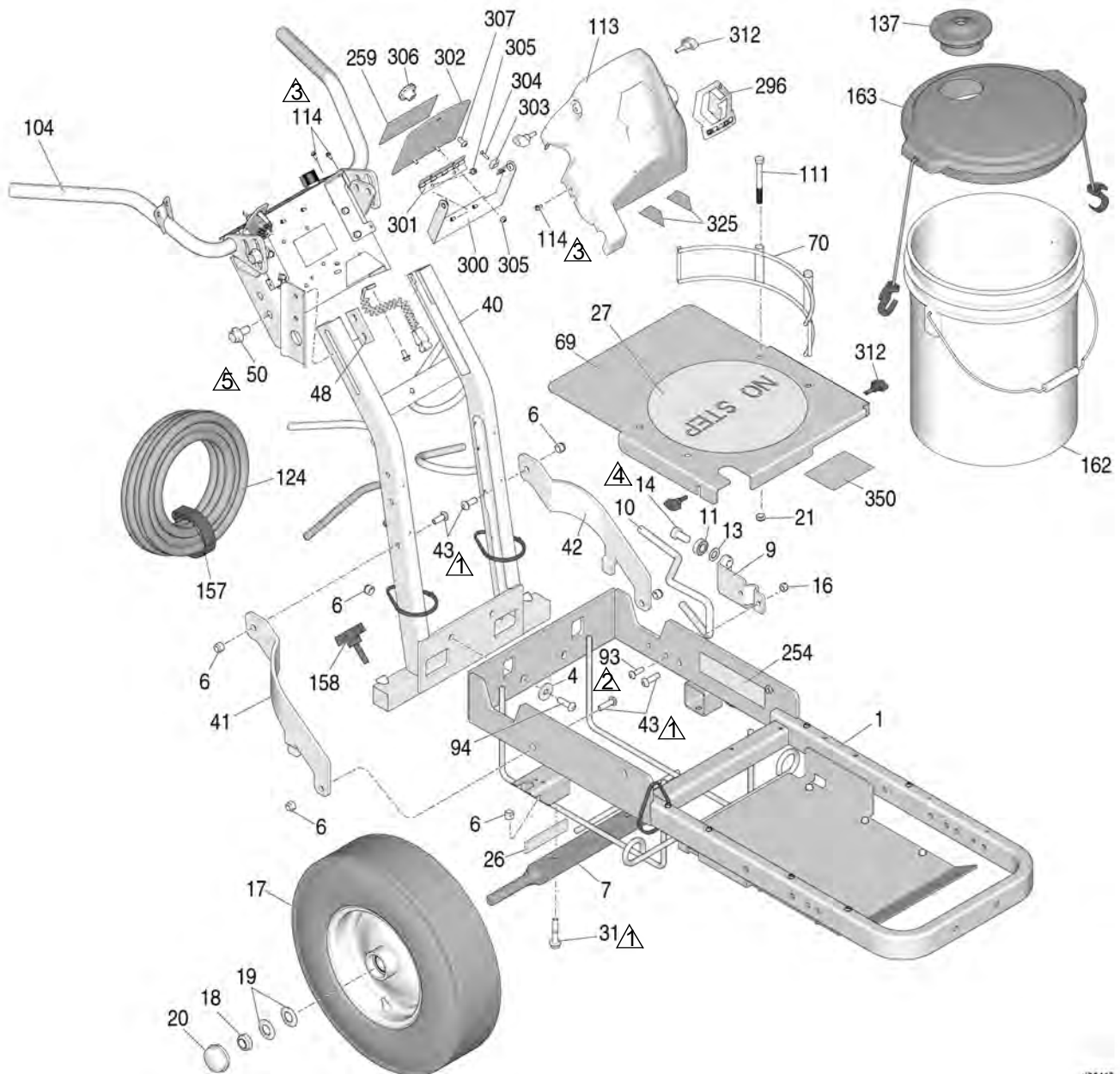

t30462a

Parts List - ES 1000

Ref.	Part	Description	Qty	Ref.	Part	Description	Qty
1	17N763	FRAME, linestriper	1	94	129601	SCREW, cap, btn hd, 3/8 x 1.25	4
4	108851	WASHER, plain	4	104	17N451	CONTROL, assembly, LL ES	1
6	101566	NUT, lock	12	111	867517	SCREW, hex head, 3/8-16 x 3.5"	4
7	193405	AXLE	1	113	17J135	COVER, control	1
9	198891	BRACKET	1	137	278723	GASKET, pail	1
10	198930	ROD, brake	1	124	249080	HOSE, cpld, 1/4" x 50'	1
11	198931	BEARING	1	157	114271	STRAP, retaining	1
13	195134	SPACER, ball, guide	1	158	108471	KNOB, pronged	1
14	113961	SCREW, cap, hex hd	1	162	115077	PAIL, plastic	1
16	111040	NUT, lock, insert, nylock, 5/16	4	163	24U241	KIT, pail cover	1
17	111020	WHEEL, pneumatic	2	254▲	17K396	LABEL, safety	1
18	112405	NUT, lock	3	259	17N740	LABEL, tool box	1
19	112825	WASHER, belleville	6	296	17K379	LABEL, console	1
20	114648	CAP, dust	2	300	17K235	BRACKET, access door	1
21	125205	NUT, lock, nylon, 3/8-16	5	301	17K236	HINGE, access door	1
26	17P800	BUMPER	2	302	17K291	DOOR, access, painted	1
27	17P831	PAD, non-slip, no step	1	303	17K309	MAGNET, square	2
31	114982	SCREW, cap, flng hd	6	304	107070	SCREW, mach, flh	2
40	24Y665	FRAME, handle upright	1	305	109466	NUT, lock, hex	4
41	15F576	BRACE, right	1	306	17K320	KNOB, ribbed	1
42	15F577	BRACE, left	1	307	112925	SCREW, cap	1
43	128977	SCREW, cap, btn hd, 3/8 x 1	2	312	16W408	KNOB, t-handle, 1/4-20 thd stud	4
48	17J125	BRACKET, slide	2	325	17K584	LABEL, wire cutout	2
50	17J136	SCREW, hex, flange head	4	350	25E266	LABEL, instruction, battery hookup	1
69	17P305	PLATE, bucket holder	1				
70	17N536	HOLDER, bucket	2				
93	125112	SCREW, cap, btn hd, 5/16 x 1	2				

▲ Replacement safety labels, tags, and cards are available at no cost.

Parts Drawing - ES 1000

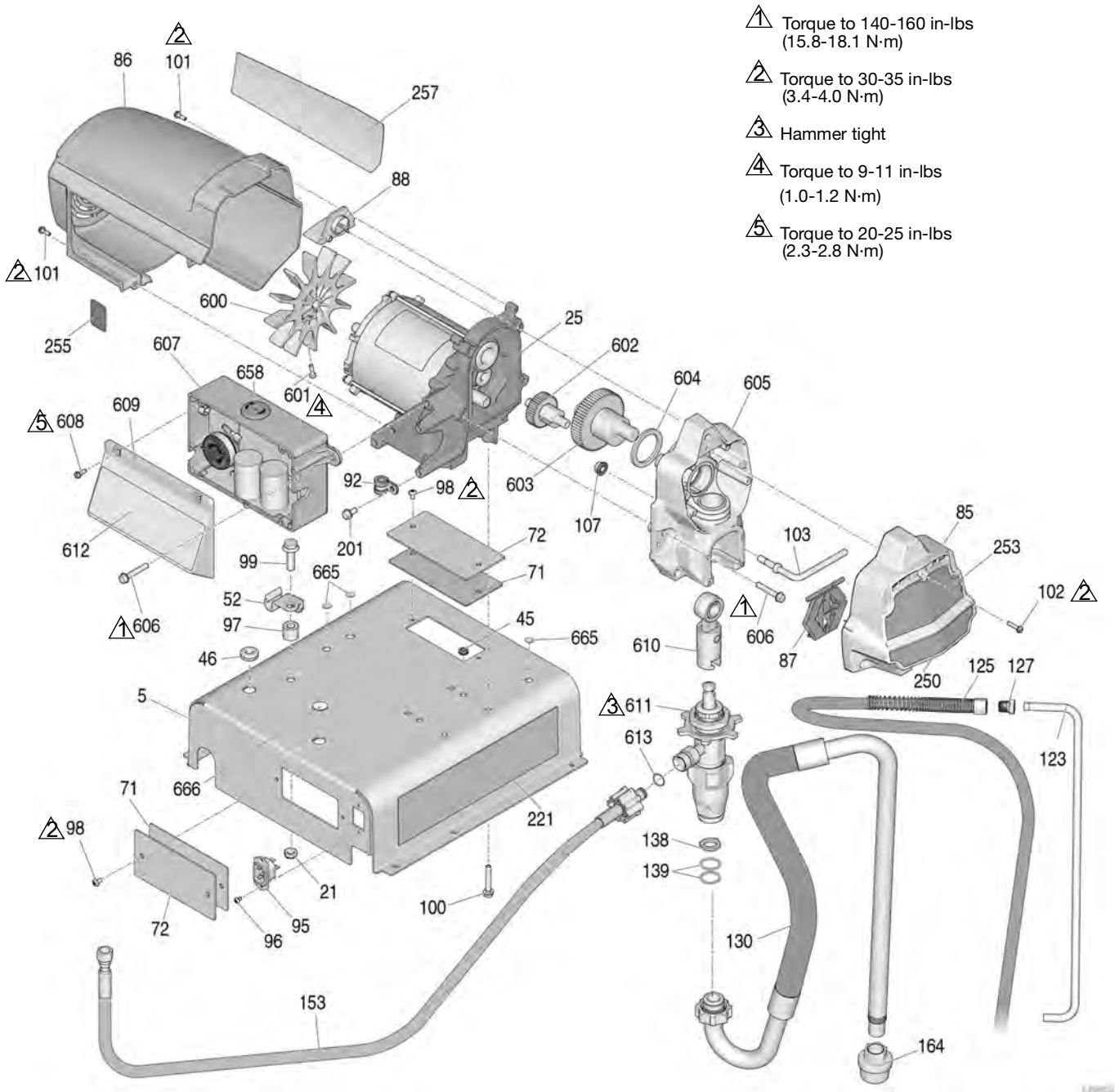

- Torque to 140-160 in-lbs (15.8-18.1 N·m)
- Torque to 30-35 in-lbs (3.4-4.0 N·m)
- Hammer tight
- Torque to 9-11 in-lbs (1.0-1.2 N·m)
- Torque to 20-25 in-lbs (2.3-2.8 N·m)

Parts List - ES 1000

Ref.	Part	Description	Qty	Ref.	Part	Description	Qty
5	17P496	COVER, inverter	1	138	115099	WASHER, garden	1
21	125205	NUT, lock, nylon, 3/8-16	1	139	117559	O-RING	2
25	24S022	MOTOR, electric	1	153	17N217	HOSE, coupled	1
45	129604	GROMMET, rubber	2	164	187651	STRAINER, 3/4-16 unf	1
46	17N444	GROMMET	1	201	107254	SCREW, thd forming	5
52	278204	CLIP, drain line	1	221▲	17N658	LABEL, warning	1
71	17P506	GASKET, access port	2	250	17N730	LABEL, front, bottom	1
72	17P497	COVER, access port	2	253	17N729	LABEL, front, brand	1
85	17C541	COVER, front	1	255▲	195793	LABEL, warning	1
86	287900	SHIELD, motor (includes 101)	1	257	17N731	LABEL, side	1
87	17C483	COVER, PC pro pump rod	1	600	15D088	FAN, motor	1
88	15G447	PLUG, shield	1	601	115477	SCREW, mach	1
91	17N989	WIRE, jumper, 18 awg, white	1	602	249194	GEAR, reducer	1
92	125220	CLAMP, cushion, support	1	603	24X020	GEAR, crankshaft	1
95	114064	PLUG, inlet	1	604	180131	BEARING, thrust	1
96	15W998	SCREW, mach	2	605	24W817	HOUSING, drive	1
97	129627	SPACER, nylon	1	606	117493	SCREW, mach	7
98	108795	SCREW, mach	4	607a	25M490	BOX, control, 120V	1
99	111193	SCREW, cap	1	607b	25M491	BOX, control, 230V	1
100	117493	SCREW, mach, hex washer hd	4	608	117501	SCREW, mach	4
101	117501	SCREW, mach, slot hex wash hd	4	609	277229	COVER, control	1
102	127914	SCREW, mach, slot hex wash hd	3	610	24W640	ROD, connecting	1
103	17P888	GUIDE, hose	1	611	24Z731	PUMP, displacement	1
107	110996	NUT, hex, flange head	1	612	17C964	LABEL, smart control	1
123	16X071	TUBE, drain line	1	613	16H137	O-RING	1
125	248008	HOSE, cpld, 1/4" x 44"	1	665	131737	PLUG, sheet metal	3
126	15F624	NUT, cable, gun	2	666	126044	PLUG, cap, .75 dia.	1
127	196180	BUSHING	1				
130	17M875	HOSE, suction	1				
137	278723	GASKET, pail	1				

▲ Replacement safety labels, tags, and cards are available at no cost.

Parts Drawing - ES 1000

 Torque to 8-10 ft-lbs
(10.8-13.6 N-m)

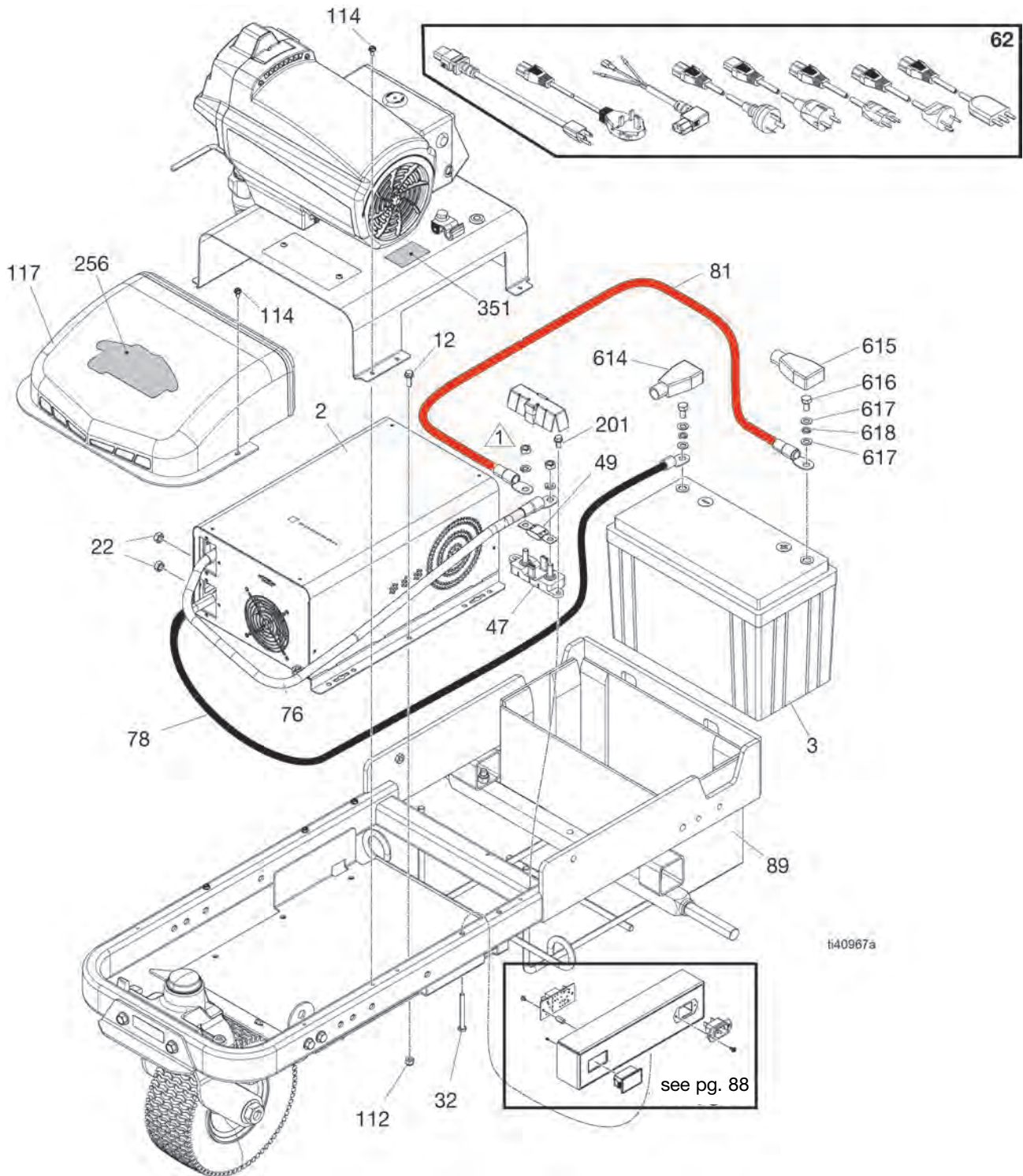

Parts List - ES 1000

Ref.	Part	Description	Qty	Ref.	Part	Description	Qty
2a	25N794	INVERTER, power supply, 120V	1	76	17M321	CABLE, red, dia .625 x 3 ft (includes 615)	1
2b	25N793	INVERTER, power supply, 230V	1	78	17M323	CABLE, black, dia .625 x 3.5 ft w/ cover (includes 614)	1
3	25U601	BATTERY, 12V lithium	1	81	17M322	CABLE, red, dia .625 x 2 ft w/ cover	1
12	113796	SCREW, flanged, hex hd	6	89	25U740	FILLER, plastic/foam	1
22	16A390	NUT, hex, flanged	2	112	102040	NUT, lock, hex	6
32	113469	SCREW, cap, hex hd	2	114	128978	SCREW, mach, slot hex wash hd	8
44	17N921	BOX, voltage meter, 120V	1	117	17P562	COVER, front, LL ES	1
47	17N816	HOLDER, fuse	1	201	107257	SCREW, hhd forming	2
49	131738	FUSE, 300, amp	1	256	25U745	LABEL, logo	1
62		CORD, power	1	614	129545	COVER, black	1
	17N758	US		615	129546	COVER, red	1
	17R033	AUSTRALIA		616	108768	SCREW	2
	17R034	CEE 7/7		617	104572	WASHER, lock	2
	17R035	SWITZERLAND		618	108788	WASHER, flat	4
	17R036	DENMARK		351	17Y815	LABEL, notice, water	1
	17R037	ITALY					
	17S135	CORD, IEC, UK/IRELAND					

Parts Drawing - ES 1000

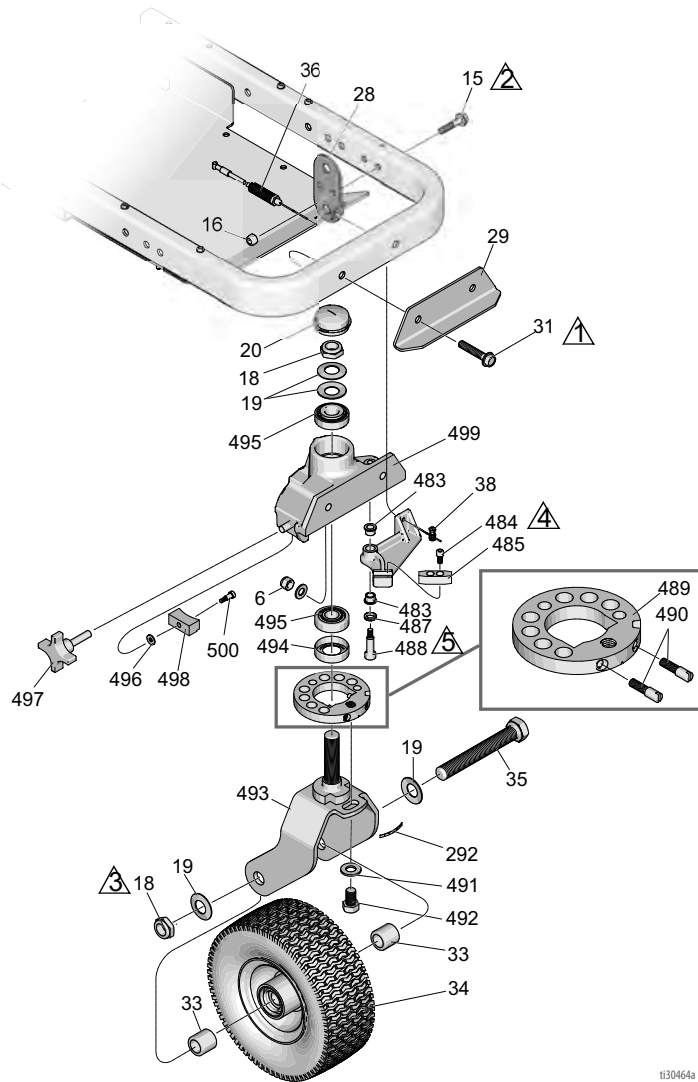

- ⚠ Torque to 17-23 ft-lbs (23.0-31.1 N-m)
- ⚠ Torque to 190-210 in-lbs (21.4-23.7 N-m)
- ⚠ Torque to 23-27 ft-lbs (31.1-36.6 N-m)
- ⚠ Torque to 60-80 in-lbs (6.7-9.0 N-m)
- ⚠ Torque to 17-23 ft-lbs (23.0-31.1 N-m)
- ⚠ Torque to 35-45 ft-lbs (47.4-61.0 N-m)
- ⚠ Torque to 365-385 in-lbs (41.2-43.4 N-m)

t130464a

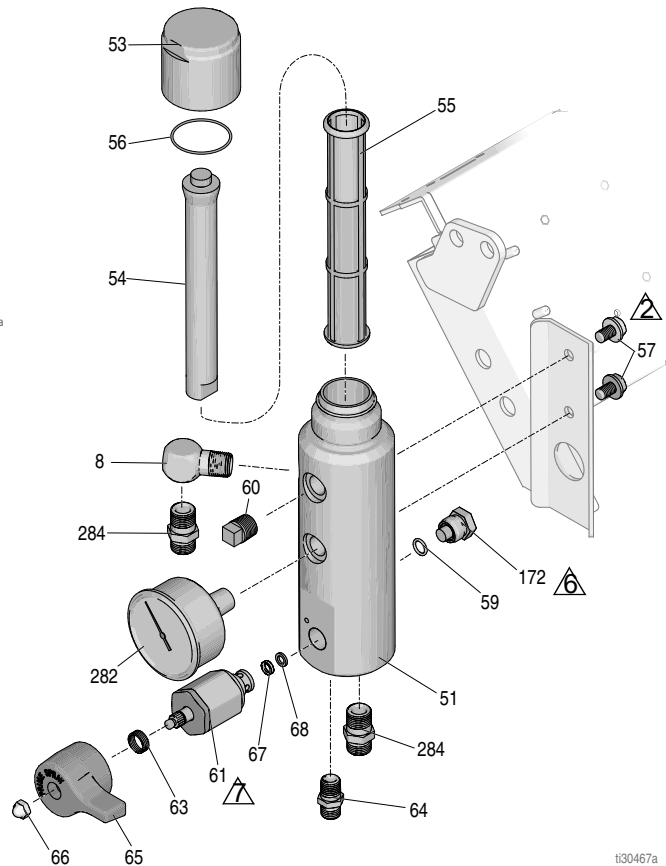

t130467a

Parts List - ES 1000

Swivel Wheel Assembly

Ref.	Part	Description	Qty
6*	101566	NUT, lock	2
8	196179	FITTING, elbow, street	1
15	112960	SCREW, cap, flng hd	2
16	111040	NUT, lock, insert, nylock, 5/16	2
18*‡	112405	NUT, lock	2
19*‡	112825	WASHER, belleville	4
20*‡	114648	CAP, dust	1
28‡	15F910	BRACKET, cable	1
29	240991	BRACKET, caster, front	1
31	114982	SCREW, cap, flng hd	2
33*‡	193658	SPACER, seal	2
34*	114549	WHEEL, pneumatic	1
35*	113471	SCREW, cap, hex hd	1
36	241105	CABLE	1
38‡	114802	STOP, wire	1
292*‡	17H489	LABEL, disk adjustment	1
483*‡	114548	BEARING, bronze	2
484*‡	110754	SCREW, cap, sch	2
485*‡	193662	STOP, wedge	1
487*‡	15J603	SPACER, round	1
488*‡	120476	BOLT, shoulder	1
489*‡	17H486	DISK, adjuster, assembly	1
490*‡	17G762	SCREW, disk adjuster	2
491*‡	113962	WASHER	1
492*‡	114681	SCREW, cap, hex hd	1
493*‡	17H485	FORK	1
494*‡	113484	SEAL, grease	1
495*‡	113485	BEARING, cup/cone	2
496*‡	112776	WASHER, plain	1
497*‡	181818	KNOB, pronged	1
498*‡	193661	JAW	1
499*‡	15G952	CASTER	1
500*‡	108483	SCREW, shoulder	1

* Included in Swivel Wheel Repair Kit 240719

‡ Included in Swivel Wheel Repair Kit 241105



Filter

Ref.	Part	Description	Qty
51	17K166	MANIFOLD, filter	1
53	17E680	CAP, filter	1
54	15C766	TUBE, diffusion	1
55	243984	FILTER, fluid	1
56	117285	PACKING, o-ring	1
57	111801	SCREW, cap, hex hd	2
59	111457	PACKING, o-ring	1
60	15G331	PLUG, pipe	1
61†	287879	VALVE, drain, assy	1
63†	114708	SPRING, compression	1
64	196181	FITTING, nipple	1
65†	15G563	HANDLE, valve	1
66†	116424	NUT, cap	1
67†	193709	SEAT, valve	1
68†	193710	SEAL, seat valve	1
172	17R281	TRANSDUCER	1
282	868015	GAUGE, pressure, 0-5000 psi	1
284	196177	ADAPTER, nipple	2

† Included in Prime Valve Repair Kit 245103

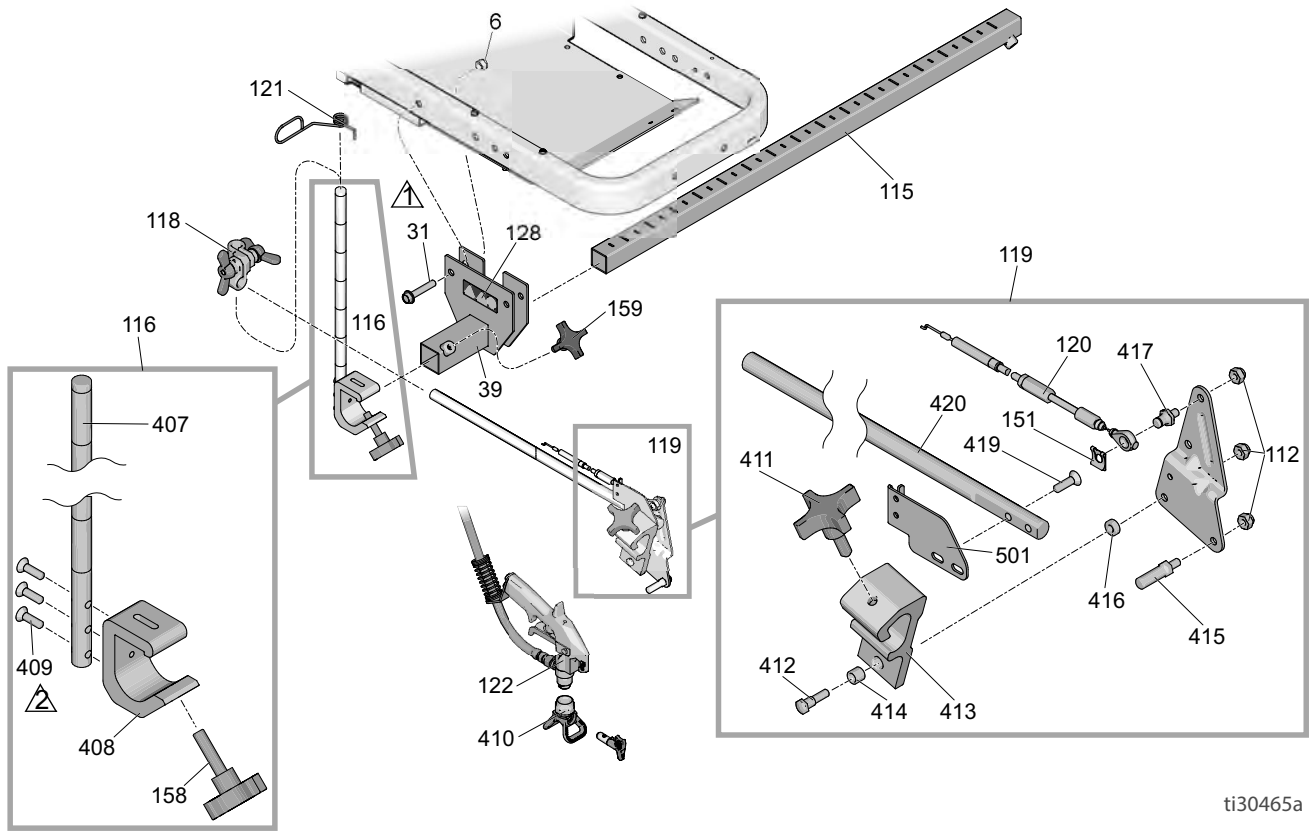
Parts Drawing - ES 1000



-  Torque to 17-23 ft-lbs (23.0-31.1 N-m)
-  Torque to 145-155 in-lbs (16.3-17.5 N-m)

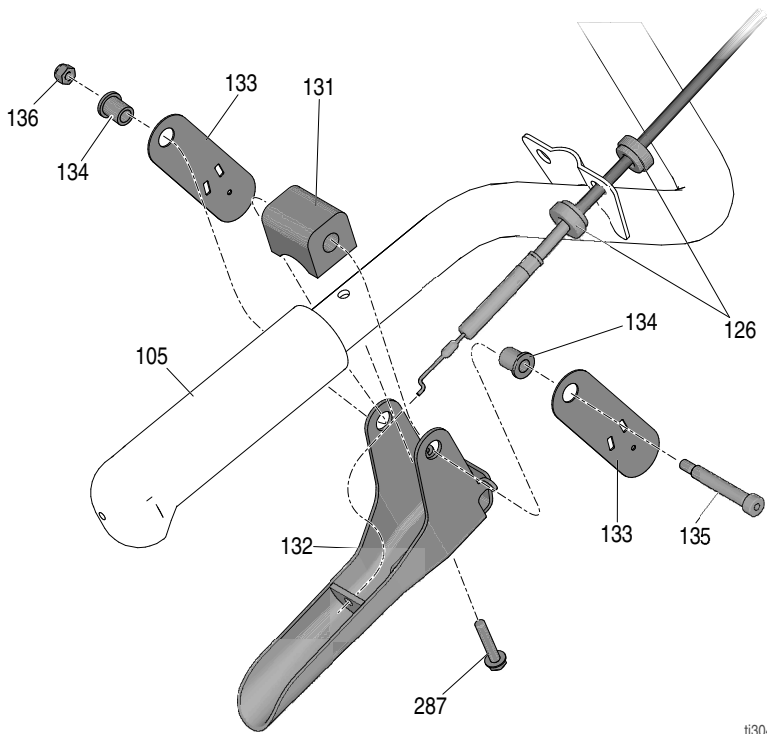

Parts List - ES 1000

Gun Holder and Arm

Ref.	Part	Description	Qty
6	101566	NUT, lock	2
31	114982	SCREW, cap, flng hd	2
39	17N447	BRACKET, gun arm	1
112	102040	NUT, lock, hex	3
115	17J407	ARM, extension, bar, weldment	1
116	17J424	BAR, heigh adjustment, assy	1
118	24Y645	KIT, clamp	1
119	25A528	BAR, gun holder	1
120	287696	CABLE, gun	1
121	188135	GUIDE, cable	1
122	235457	GUN, flex, basic	1
128▲	16P136	LABEL, safety, warning, iso	1
151	126111	RETAINER, cir-clip, external, 8mm	1
158	108471	KNOG, pronged	1
159	111145	KNOB, pronged	1
407	17J139	BAR, gun, height, adjustment	1
408	17J153	BRACKET, gun, holder	1
409	113428	SCREW, mach, hex hd	3
410	243161	GUARD	1
411‡	15F750	KNOB, holder, gun	1
412	17J575	FASTENER	1
413‡	15F216	HOLDER, gun	1
414‡	119664	BEARING, sleeve	1
415	15F209	STUD, pull, trigger	1
416	17J576	SPACER	1
417	17H673	STUD, cable	1
418	15F214	ACTUATOR, lever	1
419	119647	SCREW, cap, socket	2
420	17J145	ARM, holder, gun	1
501	15F213	BRACKET, cable	1
504	LL5317	STRIPING TIP	1
	LL5319	STRIPING TIP	1

▲ Replacement safety labels, tags, and cards are available at no cost.

‡ Included in Gun Holder Repair Kit 287569

Gun Trigger

Ref.	Part	Description	Qty
105	114659	GRIP, handle	2
126	15F624	NUT, cable, gun	2
131	198896	BLOCK, mounting	1
132	245676	HANDLE	1
133	198895	PLATE, lever, pivot	2
134	111017	BEARING, flange	2
135	116941	SCREW, shoulder	1
136	129476	NUT, lock w/ nylon insert	1
287	128803	SCREW, thd forming, hex washer	1

Parts Drawing - ES 1000

 Torque to 18-22 in-lbs
(2.0-2.4 N·m)

 Torque to 28-32 in-lbs
(3.1-3.6 N·m)

 Torque to 45-55 ft-lbs
(61.0-74.5 N·m)

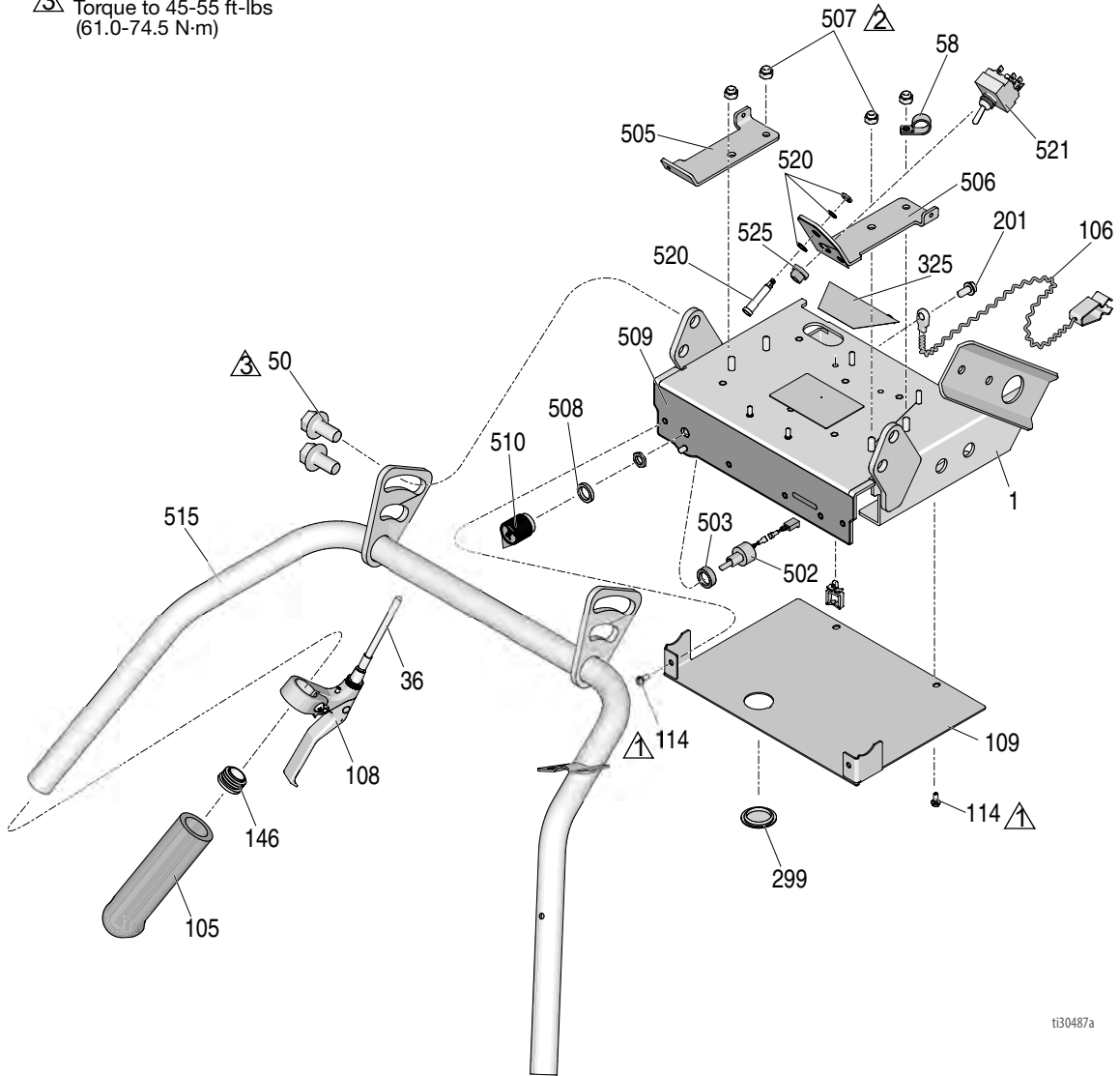

t330487a

Parts List - ES 1000

Ref.	Part	Description	Qty	Ref.	Part	Description	Qty
36	241105	CABLE	1	502	17N443	POTENTIOMETER	1
50	17J136	SCREW, hex, flange hd	4	503	198650	SPACER, shaft	1
58	113491	CLAMP, wire	1	505	17J126	BRACKET, shroud	1
105	114659	GRIP, handle	1	506	17N419	BRACKET, switch	1
106	237686	GROUNDING, clip	1	507	102040	NUT, lock, hex	4
108	194310	LEVEL, actuator	1	508	15C973	GASKET	1
109	17J123	PLATE, cover	1	509	17N416	LABEL, control	1
114	128978	SCREW, mach, slot hex wash hd	8	510	116167	KNOB, potentiometer	1
146	120151	PLUG, tube	2	515	24Y641	BAR, handle	1
299	17K310	PLUG, button	1	520	17N435	INDICATOR, LED, panel mount	1
325	17K584	LABEL, wire cutout	1	521	17N418	SWITCH, toggle	1
501	24Y642	PLATE, control, Weldment	1	525	195428	BOOT, toggle	1

Voltage Meter Box, 120V (ES1000 & ES2000)

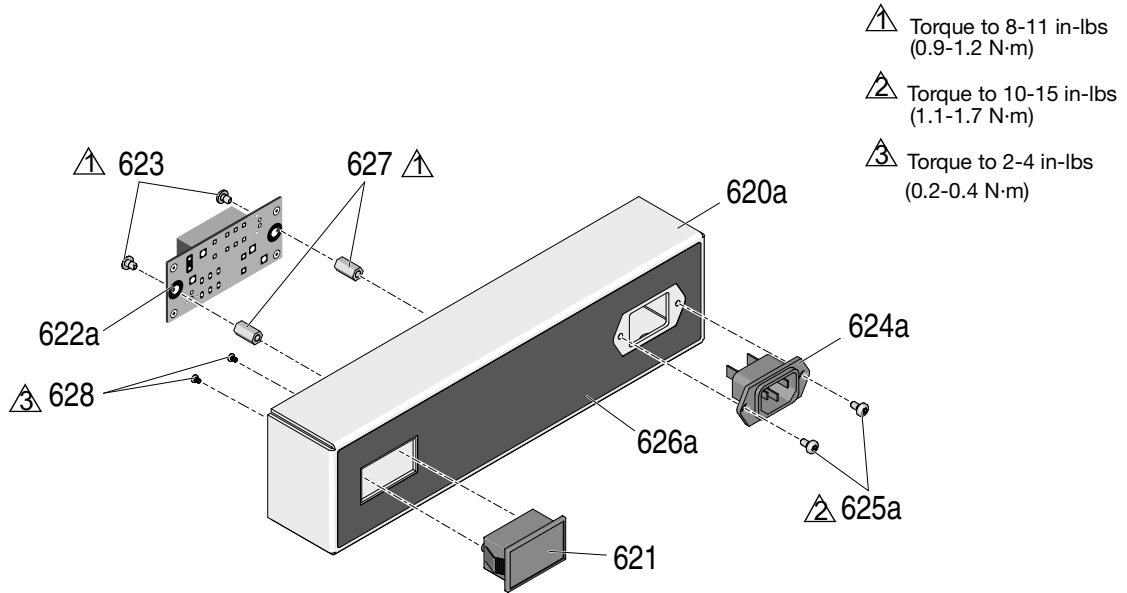

Voltage Meter Box, 230V (ES1000 & ES2000)

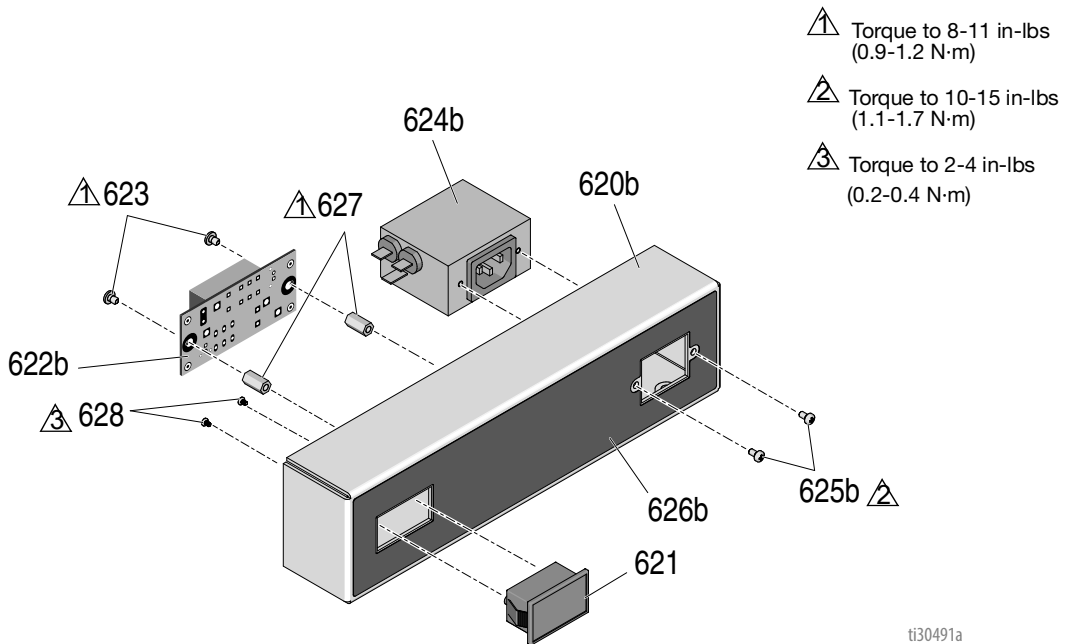

ti30491a

Parts List



Voltage Meter Box, 120V

Ref.	Part	Description	Qty
620a	17R015	PANEL, box, meter, voltage, 120V	1
621	17N638	METER, volt, digital	1
622a	25M487	KIT, repair, board, relay, 120V	1
623	104714	SCREW, mach, pnh	2
624a	114064	PLUG, inlet	1
625a	15W998	SCREW, mach, torix	2
626a	17N659	LABEL, battery, 120V AC	1
627	129510	FASTENER, threaded hex standoff	2
628	129696	SCREW, pan head, phillips	2

Voltage Meter Box, 230V

Ref.	Part	Description	Qty
620b	17N929	PANEL, box, meter, voltage, 230V	1
621	17N638	METER, volt, digital	1
622b	25M489	KIT, repair, board, relay, 230V	1
623	104714	SCREW, mach, pnh	2
624b	129649	FILTER, inlet	1
625b	119912	SCREW, mach, phillips	2
626b	17N753	LABEL, battery, 230V AC	1
627	129510	FASTENER, threaded hex standoff	2
628	129696	SCREW, pan head, phillips	2

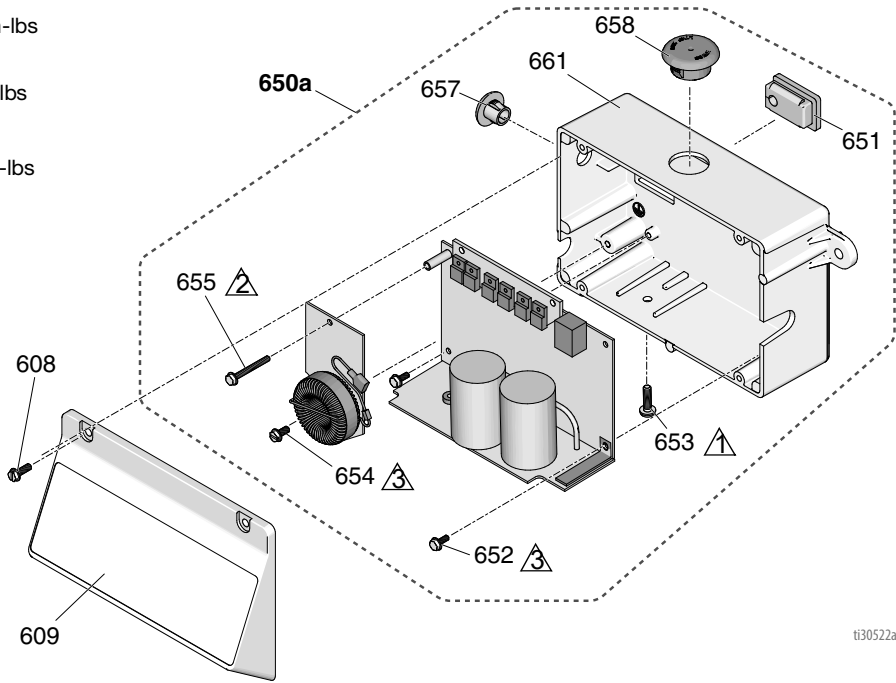

Control Box, 120V (ES 1000)

-  Torque to 20-25 in-lbs (2.3-2.8 N·m)
-  Torque to 12±2 in-lbs (1.4 ± 2 N·m)
-  Torque to 30-35 in-lbs (3.4-3.9 N·m)



ti30522a

Control Box, 230V (ES 1000)

-  Torque to 20-25 in-lbs (2.3-2.8 N·m)
-  Torque to 12±2 in-lbs (1.4 ± 2 N·m)
-  Torque to 30-35 in-lbs (3.4-3.9 N·m)

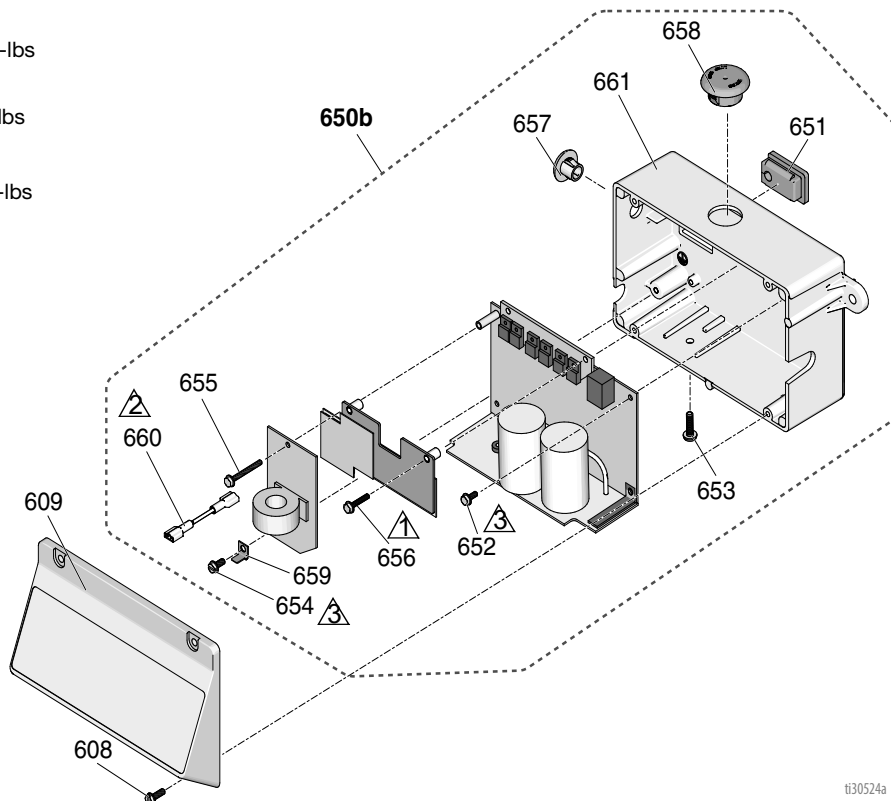

ti30524a

Parts List

Control Box, 120V (ES 1000)

Ref.	Part	Description	Qty
608	117501	SCREW, mach, slot hex wash hd	4
609	277229	COVER, control	1
650a	25M490	BOX, control board, 120V, includes 651, 652, 653, 654, 655, 657, 658	1
651	15G562	BUSHING, control box	1
652	120405	SCREW, mach, hex washer hd	2
653	120165	SCREW, mach, phillips, pan hd	1
654	123850	SCREW, tapping, slot hex wash hd	1
655	120406	SCREW, mach, hex, wash hd	1
657	16Y457	PLUG, molded	1
658	17N560	PLUG	1
661	17N559	BOX, control	1

Control Box, 230V (ES 1000)

Ref.	Part	Description	Qty
608	117501	SCREW, mach, slot hex wash hd	4
609	277229	COVER, control	1
650b	25M491	BOX, control board, 230V, includes 651, 652, 653, 654, 655, 656, 657, 658, 659, 660	1
651	15G562	BUSHING, control box	1
652	120405	SCREW, mach, hex washer hd	2
653	120165	SCREW, mach, phillips, pan hd	1
654	123850	SCREW, tapping, slot hex wash hd	1
655	120406	SCREW, mach, hex, wash hd	1
656	128038	SCREW, mach, hex wash	2
657	16Y457	PLUG, molded	1
658	17N560	PLUG	1
660	17P859	WIRE, jumper	1
661	17N559	BOX, control	1

Wiring Diagram - 120V (ES 1000)

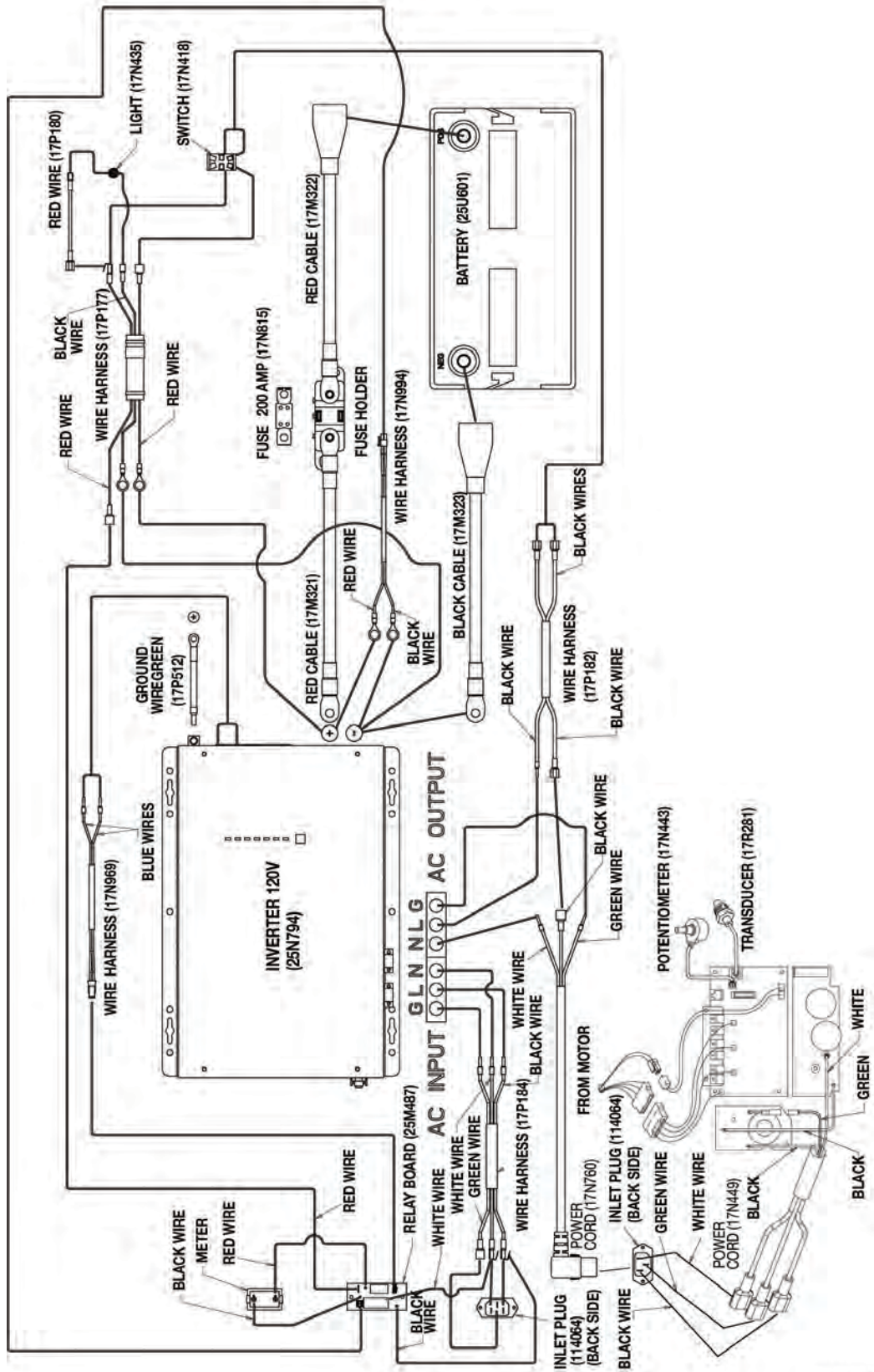

1140968a

Wiring Diagram - 230V (ES 1000)

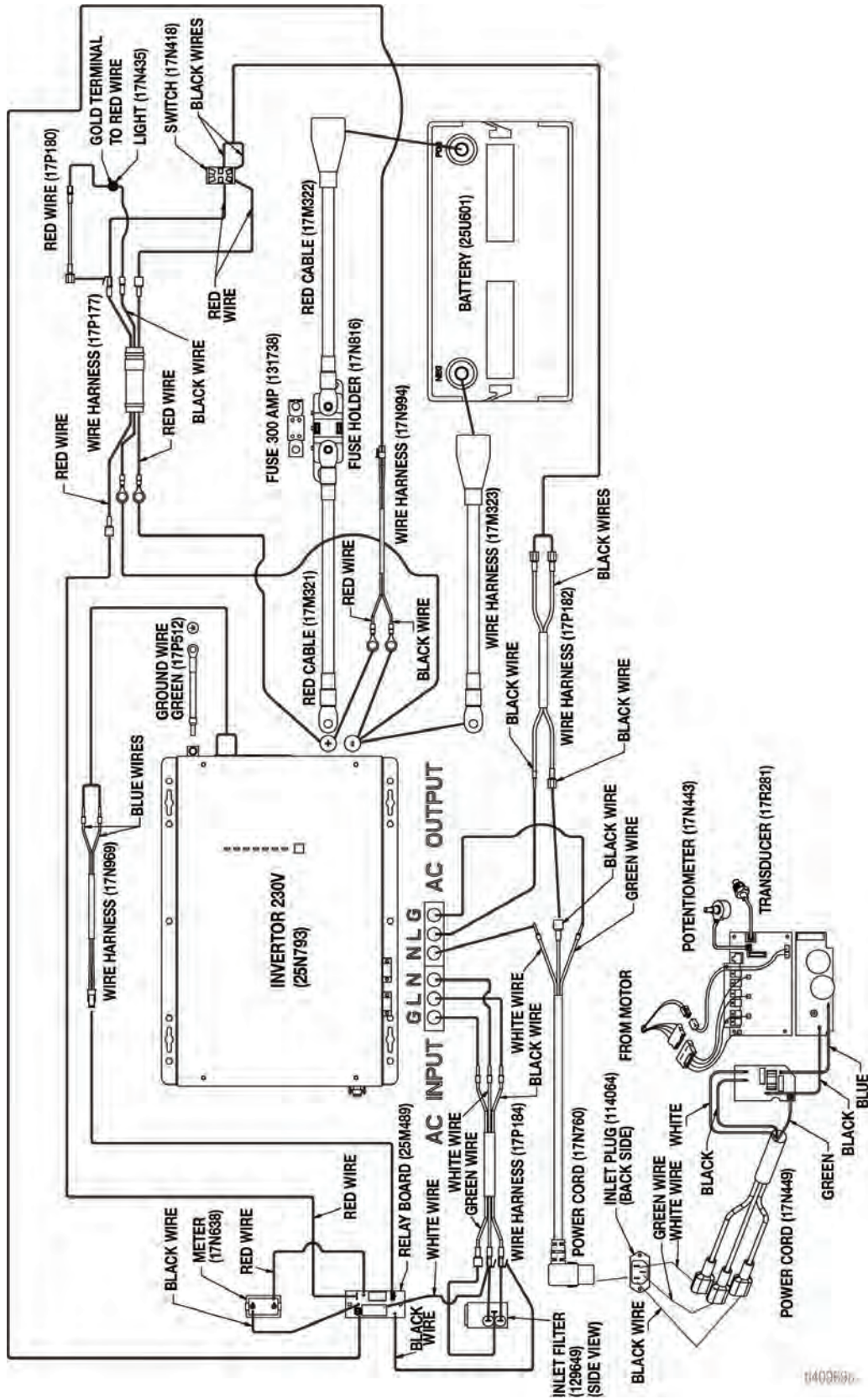

Control Board Wiring Diagram

110/120V (ES 1000)

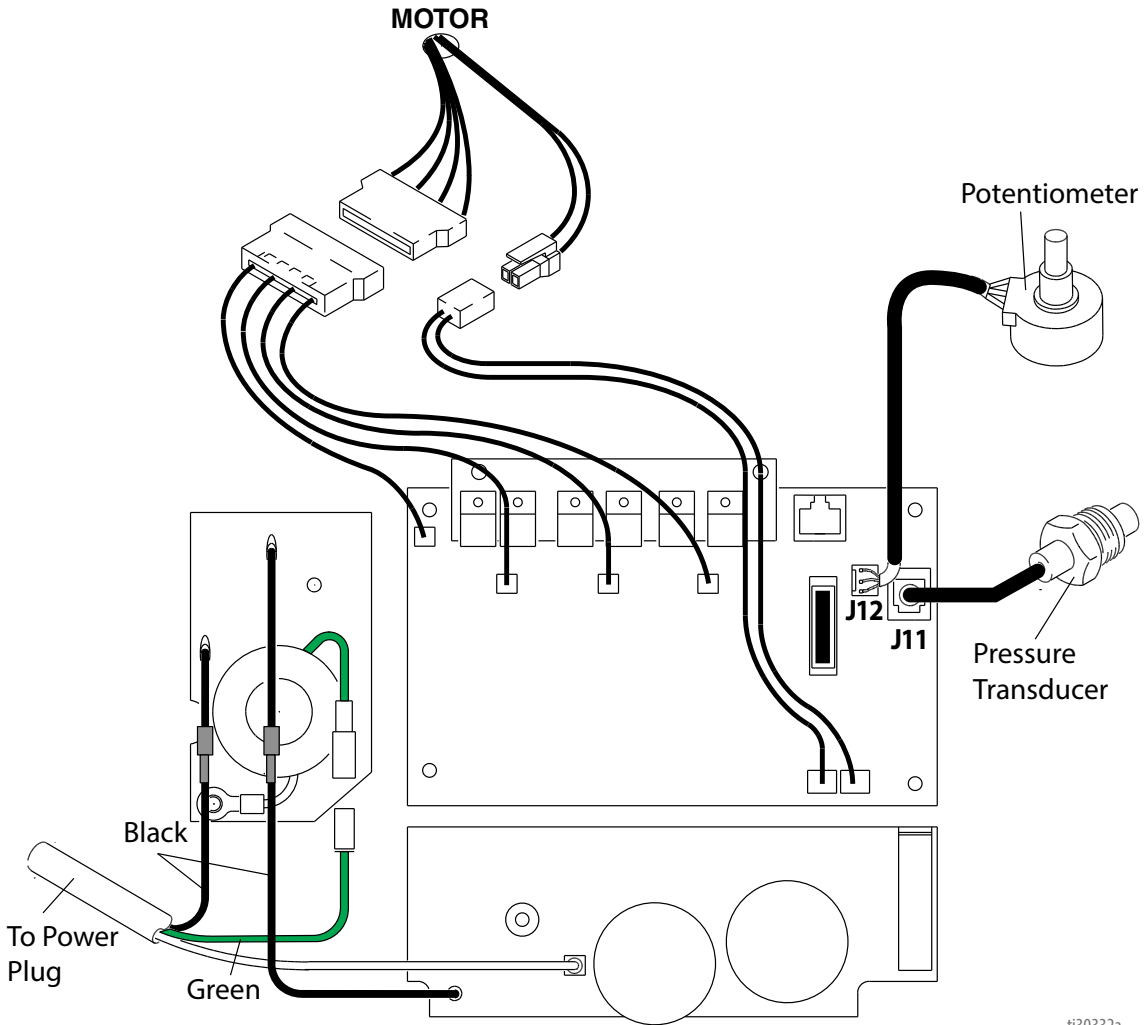

ti30332a



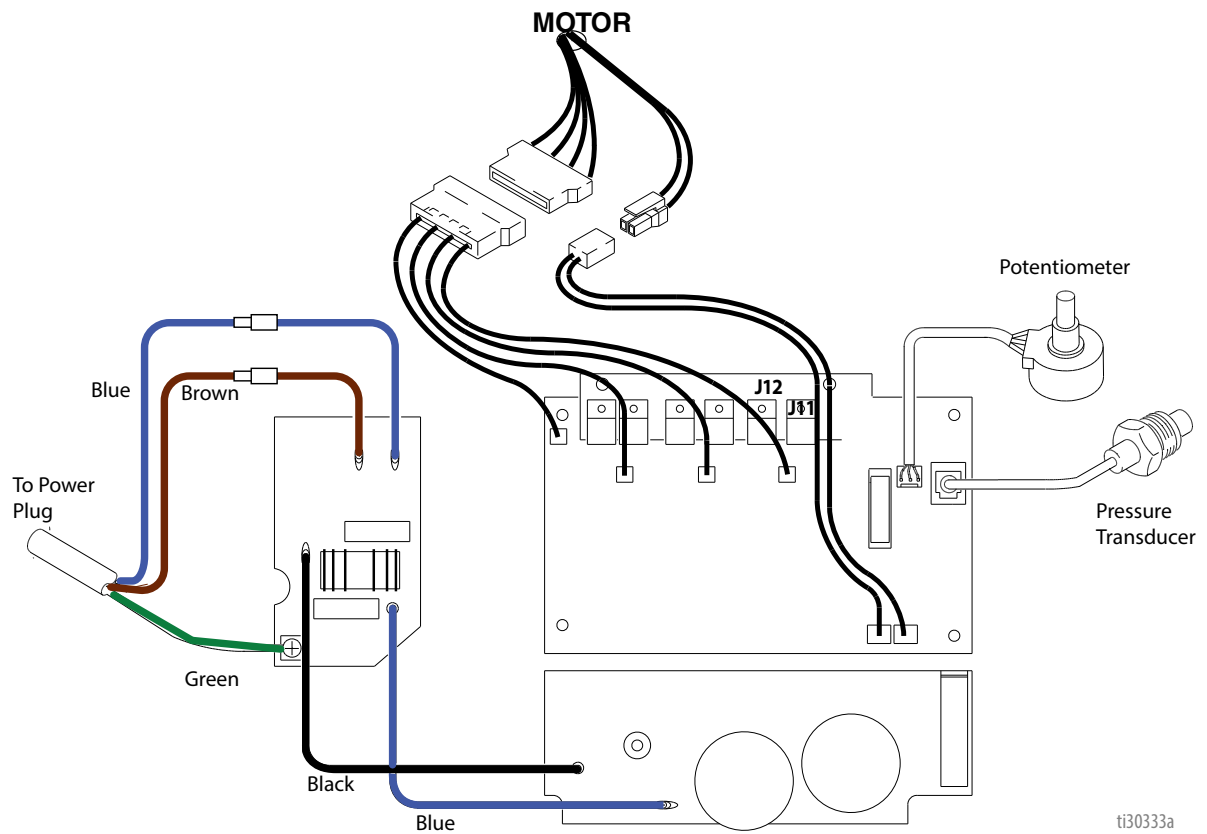

230V (ES 1000)

NOTICE

Heat from inductor coil of filter board may destroy wire insulation that comes in contact with it. Exposed wires could cause shorts and component damage. Bundle and tie loose wires so none lay in contact with inductor coil on the filter board.



Parts Drawing - ES 2000

-  Torque to 17-23 ft-lbs
(23.0-31.1 N-m)
-  Torque to 190-210 in-lbs
(21.4-23.7 N-m)
-  Torque to 18-22 in-lbs
(2.0-2.4 N-m)
-  Torque to 23-27 ft-lbs
(31.1-36.6 N-m)
-  Torque to 45-55 ft-lbs
(61.0-74.5 N-m)

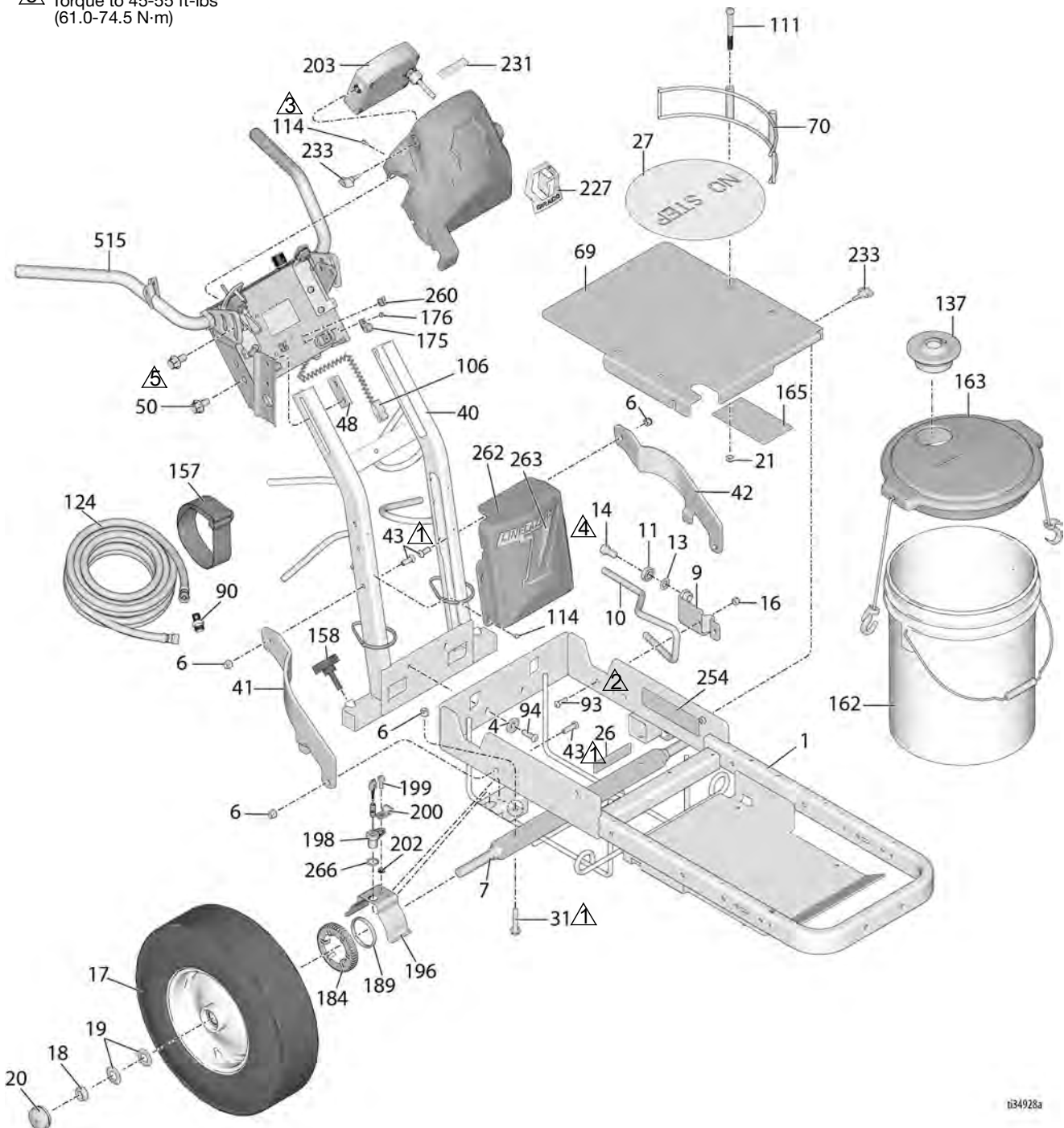







1134928a

Parts List - ES 2000

Ref.	Part	Description	Qty	Ref.	Part	Description	Qty
1	17N763	FRAME, linestriper	1	137	278723	GASKET, pail	1
4	108851	WASHER, plain	4	124	124884	HOSE, cpld, 3/8 x 22'	1
6	101566	NUT, lock	12	157	114271	STRAP, retaining	1
7	193405	AXLE	1	158	108471	KNOB, pronged	1
9	198891	BRACKET	1	162	115077	PAIL, plastic	1
10	198930	ROD, brake	1	163	24U241	KIT, pail cover	1
11	198931	BEARING	1	165	25E266	LABEL, hookup, battery	1
13	195134	SPACER, ball, guide	1	175	128856	CLAMP, cable, nylon	2
14	113961	SCREW, cap, hex hd	1	176	115483	NUT, lock	2
16	111040	NUT, lock, insert, nylock, 5/16	4	180▲	222385	LABEL, safety, medical alert (not shown)	1
17	255162	WHEEL, pneumatic (includes 184 and 189)	2	184	15J575	GEAR, signal	1
18	112405	NUT, lock	3	189	15K700	RING, sensor gear	1
19	112825	WASHER, belleville	6	196	15J088	SHIELD, distance sensor	1
20	114648	CAP, dust	2	198	15K357	SENSOR, distance	1
21	125205	NUT, lock, nylon, 3/8-16	5	199	260212	SCREW, hex washer hd	1
26	17P800	BUMPER	2	200	108868	CLAMP, wire	1
27	17P831	PAD, non-slip, no step	1	202	15K452	SPACER, round, .500 OD	1
31	114982	SCREW, cap, flng hd	6	203	25N791	KIT, repair, display	1
40	24Y665	FRAME, handle upright	1	227	17K379	LABEL, console	1
41	15F576	BRACE, right	1	229▲	17A134	LABEL, safety, medical alert (not shown)	1
42	15F577	BRACE, left	1	231	17P925	LABEL, A+ Service	1
43	128977	SCREW, cap, btn hd, 3/8 x 1	2	233	16W408	KNOB, t-handle, 1/4-20 thd stud	4
48	17J125	BRACKET, slide	2	254▲	17K396	LABEL, safety	1
50	17J136	SCREW, hex, flange head	4	260	114687	CLIP, retainer	2
69	17P305	PLATE, bucket holder	1	262	17K377	COVER, battery	1
70	17N536	HOLDER, bucket	2	263	17K378	LABEL, brand, LLV	1
90	196176	ADAPTER, nipple	1	266	155500	PACKING, o-ring	1
93	125112	SCREW, cap, btn hd, 5/16 x 1	2	515	24Y641	BAR, handle	1
94	129601	SCREW, cap, btn hd, 3/8 x 1.25	4				
106	237686	CLIP, grounding	1				
111	867517	SCREW, hex head, 3/8-16 x 3.5"	4				

▲ Replacement safety labels, tags, and cards are available at no cost.

Parts Drawing - ES 2000

-  Torque to 25-30 ft-lbs (34-41 N-m)
-  Torque to 30-35 in-lbs (3.4-4.0 N-m)
-  Hammer tight
-  Torque to 9-11 in-lbs (1.0-1.2 N-m)
-  Torque to 40-45 in-lbs (4.5-5.1 N-m)
-  Torque to 15-20 in-lbs (1.7-2.2 N-m)

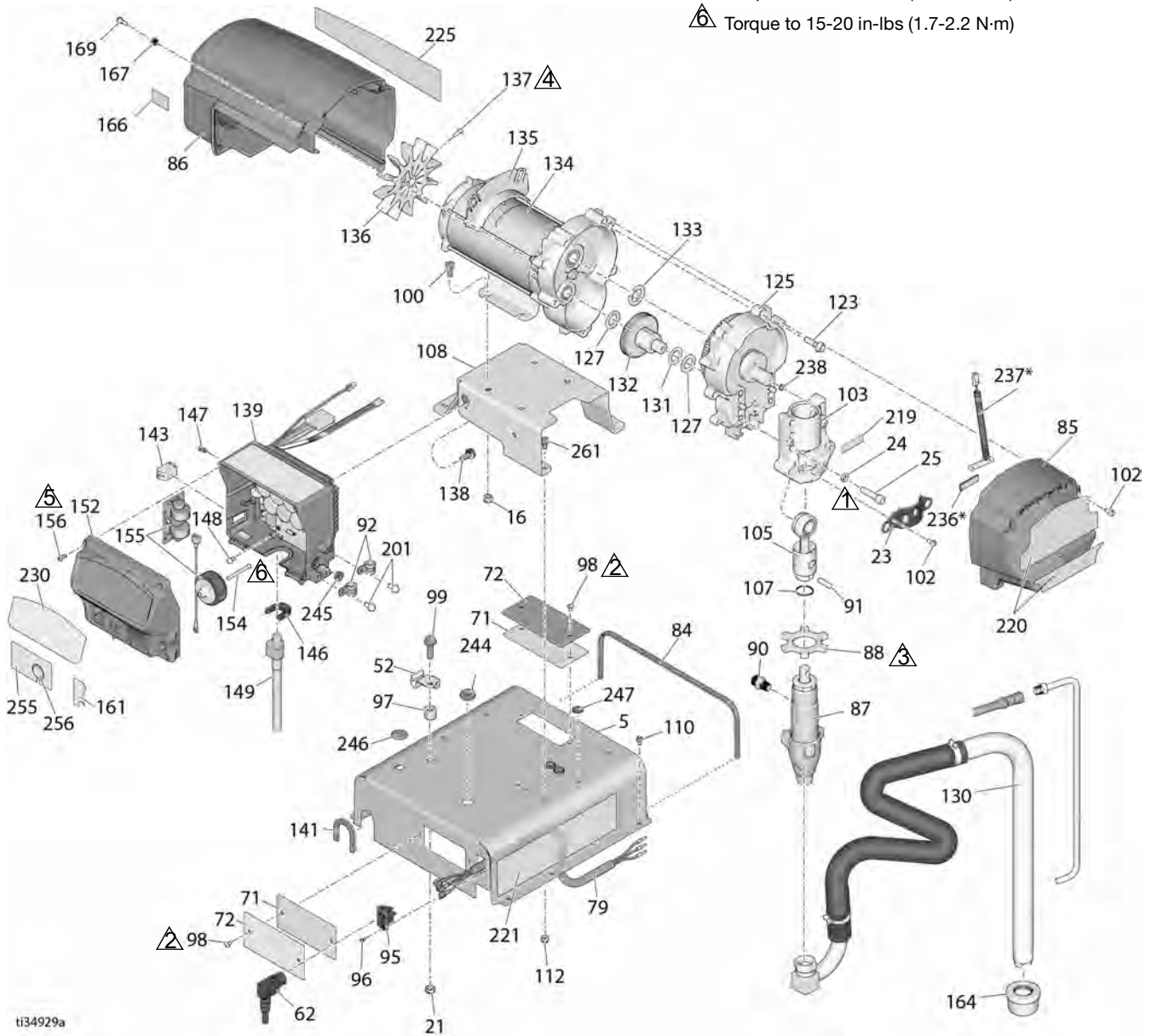

Parts List - ES 2000

Ref.	Part	Description	Qty	Ref.	Part	Description	Qty
5	17P496	COVER, inverter	1	137	115477	SCREW, mach, torx	1
16	111040	NUT, lock, 5/16	4	138	117791	SCREW, cap	2
21	125205	NUT, lock, nylon, 3/8-16	1	139		CONTROL, board (includes 143, 146, 147, 148)	1
23	16X770	SHEILD, pump rod	1		24P847	120V Models	
24	106115	WASHER, lock	4		24P848	230V Models	
25	110141	SCREW, cap, sch	4	141	17R051	TRIM, edge protection, 4.25"	1
52	278204	CLIP, drain line	1	143	16T483	PLUG, hole, switch	1
71	17P506	GASKET, access port	2	146	16T547	ADAPTER, cord	1
72	17P497	COVER, access port	2	147	16T482	RIVET, snap (120V only)	2
79	17P184	HARNESS, wire	1	148	114391	SCREW, grounding	1
84	129628	TRIM, edge, rubber foam	1	149		CORD, power	1
85	16X224	COVER, front	1		17X916	(120V only)	
86	15C775	SHIELD, motor, painted	1		17Y139	(230V only)	
87	277069	PUMP, displacement	1	152	16X161	COVER, control, ultra, std	1
88	17A257	NUT, jam, pump	1	154	16U215	SCREW, machine, flat head	1
90	196176	ADAPTER, nipple	2	155	15H063	COIL, filter (120V)	1
91	176818	PIN, pump, connecting rod	1		25B130	BOARD, filter (230V)	1
92	125220	CLAMP, cushion	2	156	16V095	SCREW, mach, pnh, torx	4
95	114064	PLUG, inlet	1	161	16Y788	LABEL, elec, std	1
96	15W998	SCREW, mach	2	164	187147	STRAINER, 3/4-16 unf	1
97	129627	SPACER, nylon	1	166	16D576	LABEL, made in USA	1
98	108795	SCREW, mach	4	167	276980	GROMMET, cover	2
99	111193	SCREW, cap	1	169	119250	SCREW, shoulder	2
100	100057	SCREW, cap, hex hd	4	201	107257	SCREW, thread forming	2
102	118444	SCREW, mach, slot hex wash hd	6	219	187437	LABEL, torque	1
103	240523	HOUSING, bearing	1	220	17Y011	LABEL, LL ES 2000, front shroud	1
105	241008	KIT, rod, connecting	1	221▲	17N658	LABEL, warning	1
107	176817	SPRING, retaining	1	225	17Y012	LABEL, LL ES 2000, side shroud	1
108	17Y020	PLATE, mount	1	230	16Y785	LABEL, brand, elec, std	1
110	113974	SCREW, mach, slotted hex wash hd	8	236	115711	TAPE, foam, 1/2" wide *(needed if replacing 237)	1
112	102040	NUT, lock, hex	9	237	17J237	SWITCH, reed *(also order 236 if replacing 237)	1
123	15C753	SCREW, mach, hex wash hd	5	238	119875	MAGNET, disc, 0.38	1
125	287284	KIT, housing, drive	1	244	130758	GROMMET, push in	1
127	114672	WASHER, thrust	2	245	130759	GROMMET, push in	1
130	24V567	HOSE, suction, set	1	246	130760	PLUG, button, 5/8 ID	1
131	114699	WASHER, thrust	1	247	131737	PLUG, sheet metal	3
132	287289	KIT, gear, combination (incldues 127 and 131)	1	255	25E264	LABEL, cover, control	1
133	116191	WASHER, thrust	1	256	25E265	LABEL, cover, round	1
134	24A701	MOTOR, electric	1	261	113161	SCREW, flange, hex hd	5
135	278075	BRACKET, wire	1				
136	15D088	FAN, motor	1				

▲ Replacement safety labels, tags, and cards are available at no cost.

Parts Drawing - ES 2000



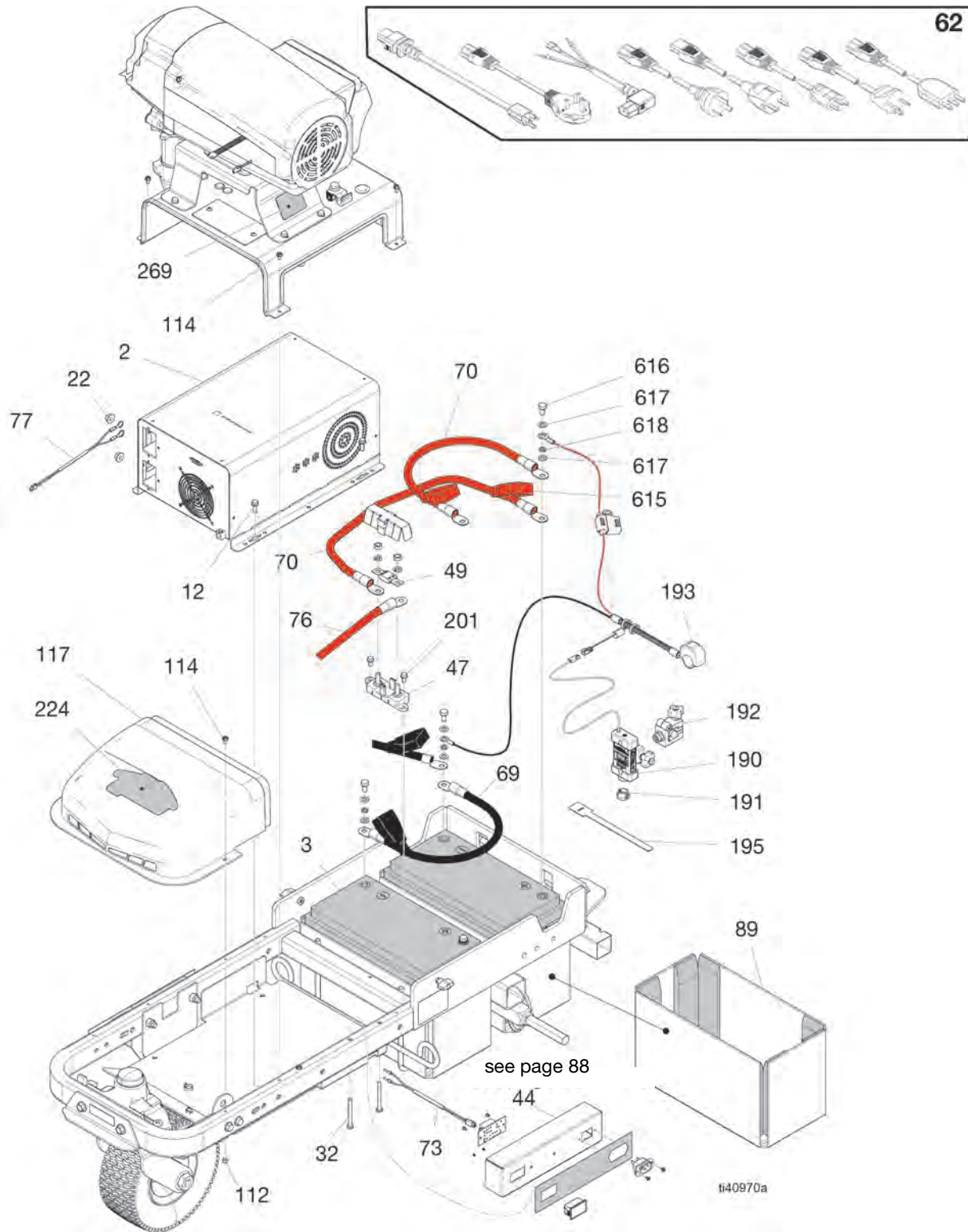

 Torque to 8-10 ft-lbs
(10.8-13.6 N·m)



Parts List - ES 2000

Ref.	Part	Description	Qty	Ref.	Part	Description	Qty
2	25N794	INVERTER, power supply, 120V	1	76	17M321	CABLE, red, dia .625 x 3 ft (includes 615)	1
	25N793	INVERTER, power supply, 230V	1	77	17N994	HARNESS, wire, volt motor power	1
3	25U601	BATTERY, 12V lithium	2	78	17M323	CABLE, black, dia .625 x 3.5 ft w/ cover (includes 614)	1
12	113796	SCREW, flanged, hex hd	4	81	17M322	CABLE, red, dia .625 x 2 ft w/ cover (includes 615)	1
22	16A390	NUT, hex, flanged	2	89	25U740	FILLER, plastic/foam	2
32	113469	SCREW, cap, hex hd	2	112	102040	NUT, lock, hex	6
44	17N921	BOX, voltage meter, 120V	1	114	128978	SCREW, mach, slot hex wash hd	2
	17N922	BOX, voltage motor, 230V	1	117	17P562	COVER, front, LL ES	1
47	17N816	HOLDER, fuse	1	190	17H714	MODULE, LazerGuide 1700	1
49	131738	FUSE, 300, amp	1	191	128917	SHIELD, paint, laser module	1
62		CORD, power	1	192	128865	BRACKET, mounting, laser	1
	17N758	US		193	17P947	SWITCH, on/off, laser	1
	17R033	AUSTRALIA		195	128854	STRAP, cable, velcro	1
	17R034	CEE 7/7		201	107257	SCREW, hhd forming	2
	17R035	SWITZERLAND		224	25U745	LABEL, LL ES, logo	1
	17R036	DENMARK		269	17Y815	LABEL, notice, water	1
	17R037	ITALY		614	129545	COVER, black	1
	17S135	CORD, IEC, UK/IRELAND		615	129546	COVER, red	1
69	17P545	CABLE, black, dia .625 x 1 ft (includes 614)	1	616	108768	SCREW	4
70	17P455	CABLE, red, dia .625 x 1 ft (includes 615)	1	617	104572	WASHER, lock	4
73	17N969	HARNESS, wire (relay to inverter)	1	618	108788	WASHER, flat	8

Parts Drawing - ES 2000

-  Torque to 35-45 ft-lbs
(47.4-61.0 N·m)
-  Torque to 190-210 in-lbs
(21.4-23.7 N·m)
-  Torque to 365-385 in-lbs
(41.2-43.4 N·m)
-  Torque to 25-30 in-lbs
(2.8-3.3 N·m)

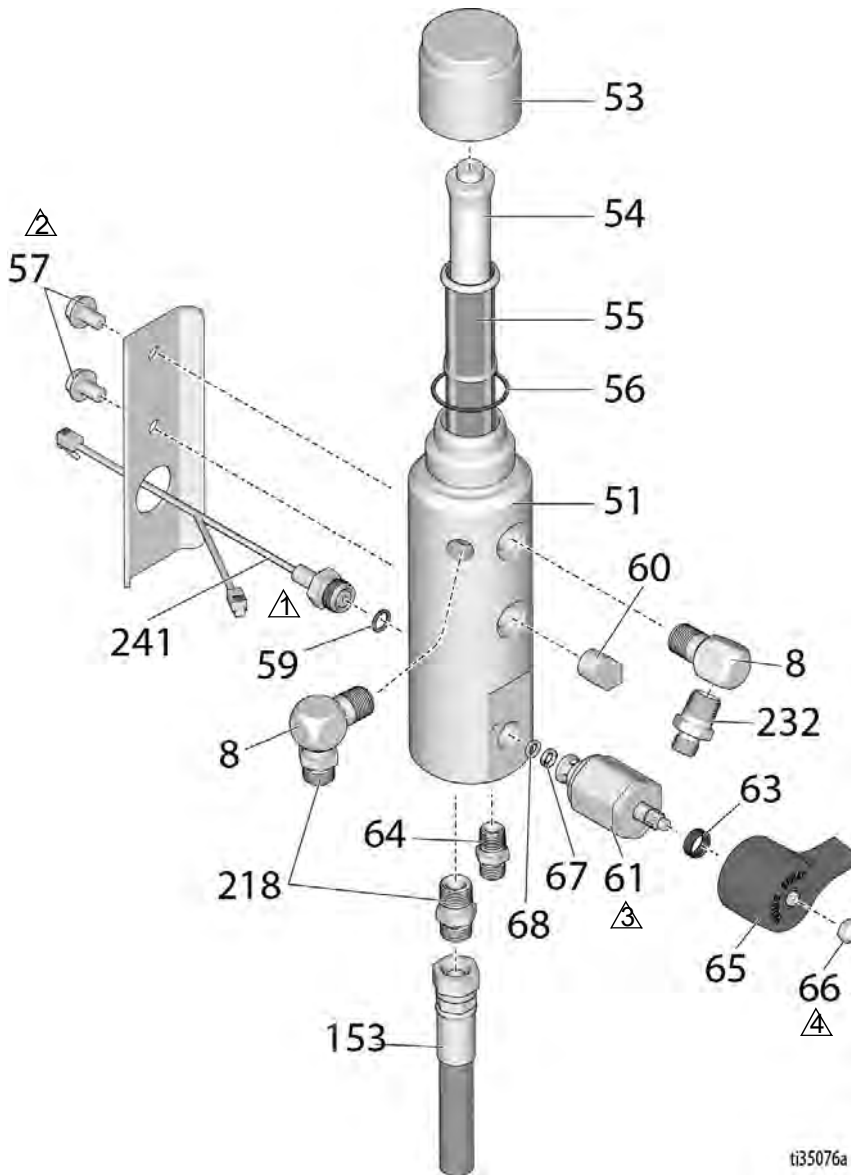





ti35076a

Parts List - ES 2000

Ref	Part	Description	Qty	Ref	Part	Description	Qty
8	196179	FITTING, elbow	2	63	114708	SPRING, compression	1
51	17K166	MANIFOLD	1	64	196181	FITTING, nipple	1
53	287285	CAP, filter (includes 54, 56)	1	65	15G563	HANDLE, valve	1
54	15C766	TUBE, diffusion	1	66	116424	NUT, cap	1
55	25A465	FILTER, fluid	1	67	193709	SEAT, valve	1
56	117285	PACKING, o-ring	1	68	193710	SEAL, seat, valve	1
57	111801	SCREW, cap, hex hd	2	153	245226	HOSE, coupled, 3/8" x 3'	1
59	111457	O-RING	1	218	196178	ADAPTER, nipple	2
60	15G331	PLUG, pipe	2	232	196177	ADAPTER, nipple	1
61	245103	VALVE, drain, assy (includes 63, 65, 66, 67, 68)	1	241	17Y099	TRANSDUCER, pressure	1

Parts Drawing - ES 2000

-  Torque to 17-23 ft-lbs
(23.0-31.1 N-m)
-  Torque to 190-210 in-lbs
(21.4-23.7 N-m)
-  Torque to 23-27 ft-lbs
(31.1-36.6 N-m)
-  Torque to 60-80 in-lbs
(6.7-9.0 N-m)
-  Torque to 17-23 ft-lbs
(23.0-31.1 N-m)

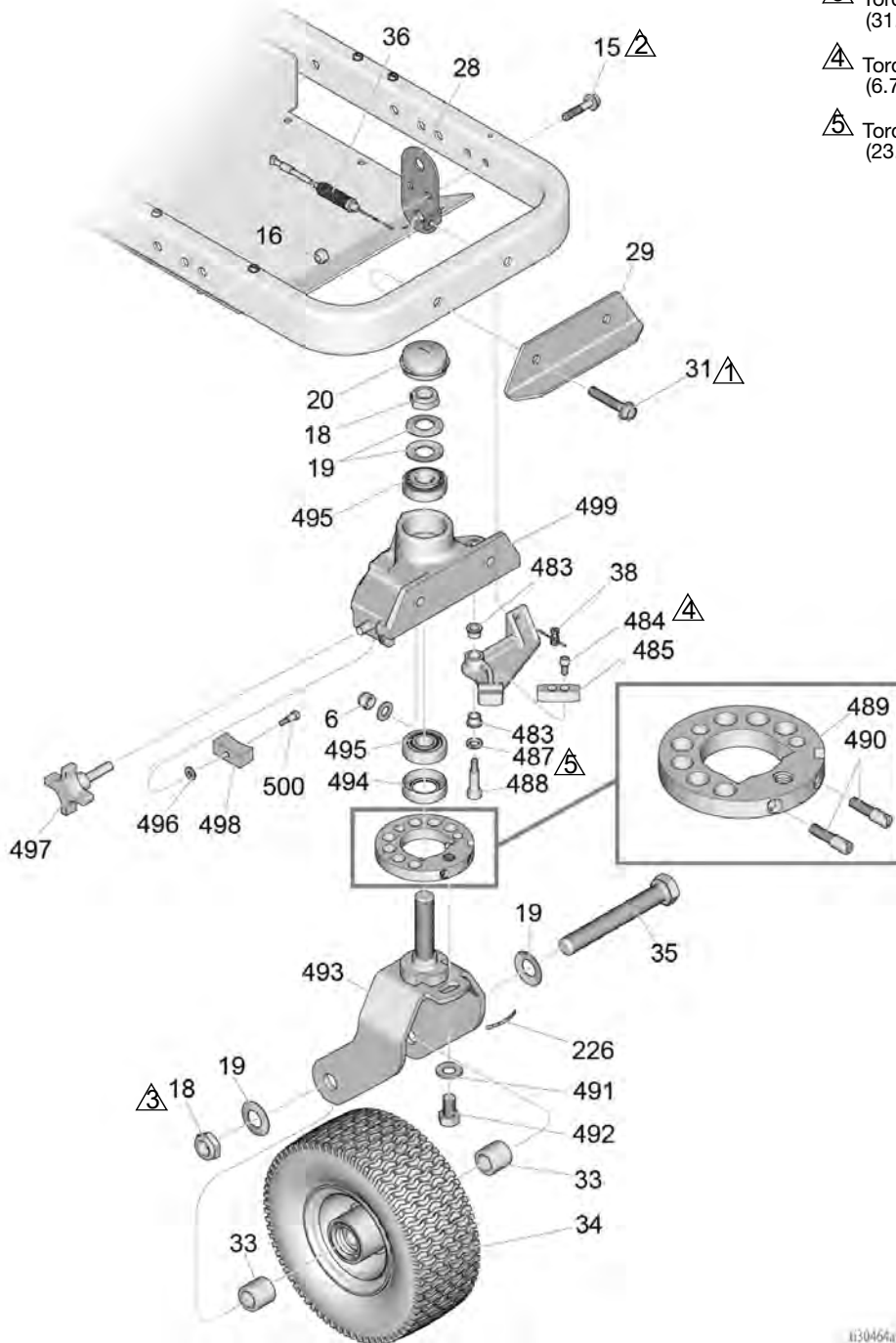

1130464

Parts List - ES 2000

Swivel Wheel Assembly

Ref.	Part	Description	Qty	Ref.	Part	Description	Qty
6*	101566	NUT, lock	2	487*‡	15J603	SPACER, round	1
15	112960	SCREW, cap, flng hd	2	488*‡	120476	BOLT, shoulder	1
16	111040	NUT, lock, insert, nylock, 5/16	2	489*‡	17H486	DISK, adjuster, assembly	1
18*‡	112405	NUT, lock	2	490*‡	17G762	SCREW, disk adjuster	2
19*‡	112825	WASHER, belleville	4	491*‡	113962	WASHER	1
20*‡	114648	CAP, dust	1	492*‡	114681	SCREW, cap, hex hd	1
28‡	15F910	BRACKET, cable	1	493*‡	17H485	FORK	1
29	240991	BRACKET, caster, front	1	494*‡	113484	SEAL, grease	1
31	114982	SCREW, cap, flng hd	2	495*‡	113485	BEARING, cup/cone	2
33*‡	193658	SPACER, seal	2	496*‡	112776	WASHER, plain	1
34*	114549	WHEEL, pneumatic	1	497*‡	181818	KNOB, pronged	1
35*	113471	SCREW, cap, hex hd	1	498*‡	193661	JAW	1
36	241105	CABLE	1	499*‡	15G952	CASTER	1
38‡	114802	STOP, wire	1	500*‡	108483	SCREW, shoulder	1
226*‡	17H489	LABEL, disk adjustment	1				
483*‡	114548	BEARING, bronze	2				
484*‡	110754	SCREW, cap, sch	2				
485*‡	193662	STOP, wedge	1				

* Included in Swivel Wheel Repair Kit 240719

‡ Included in Swivel Wheel Repair Kit 241105

Parts Drawing - ES 2000

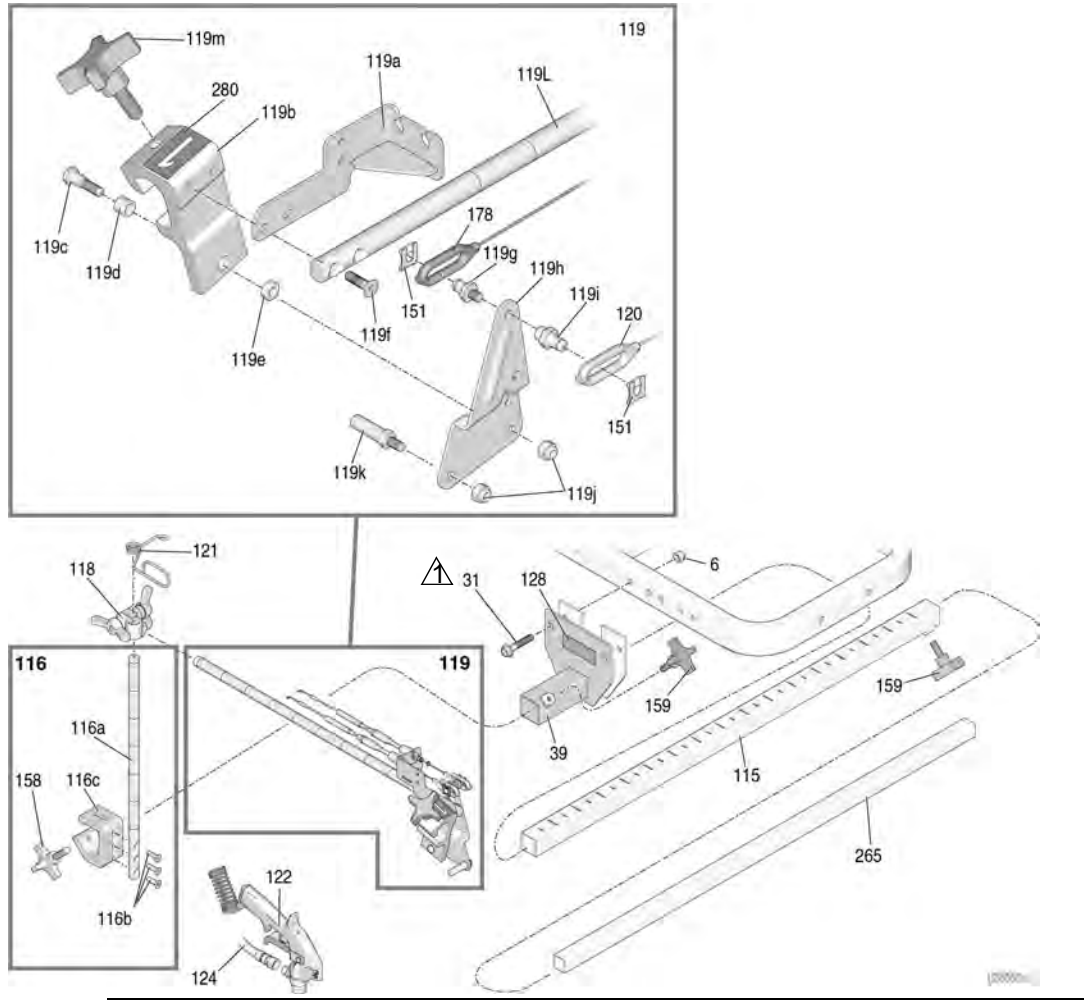

 Torque to 17-23 ft-lbs
(23.0-31.1 N·m)

 Torque to 18-22 in-lbs
(2.0-2.4 N·m)

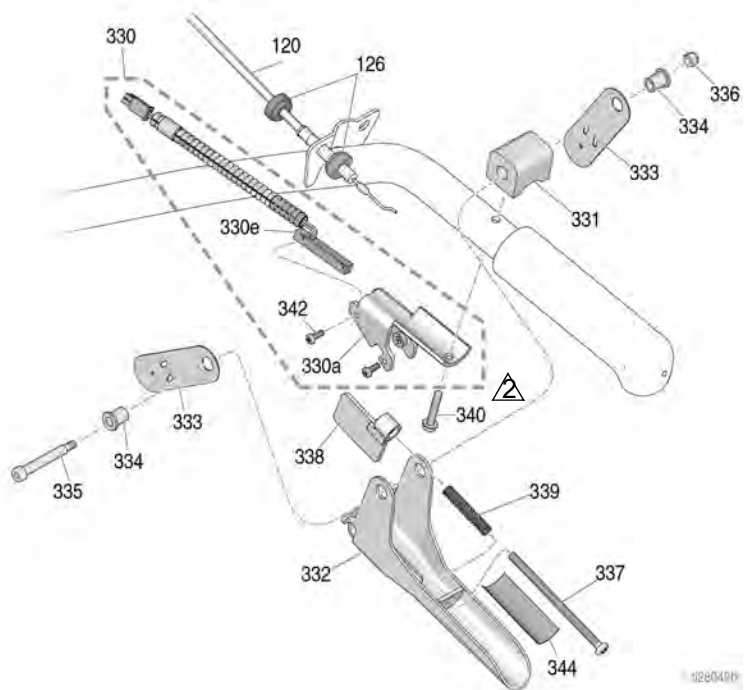

Parts List - ES 2000

Gun Holder and Arm

Ref	Part	Description	Qty
6	101566	NUT, lock	2
31	114982	SCREW, cap, flng hd	2
39	17H528	BRACKET, gun arm	1
115	17J407	ARM, extension, bar	1
116	17J424	BAR, height adjustment, assy	1
116a	17J139	BAR, gun, height, adjustment	1
116b	113428	SCREW, mach, hex, hd	3
116c	17J153	BRACKET, gun holder	1
118	24Y645	KIT, clamp, double wing nut	1
119	25A529	ARM, gun holder, linelazer (includes 151)	1
119a	24Y919	BRACKET, cable	1
119b*	15F216	HOLDER, gun	1
119c	17J575	FASTENER, special	1
119d*	119664	BEARING, sleeve	1
119e	17J576	SPACER, special	1
119f	119647	SCREW, cap, socket	2
119g	17H673	STUD, cable, gun	1
119h	15F214	LEVER, actuator	1
119i	17H674	ADAPTER, cable, gun	1
119j	102040	NUT, lock hex	2
119k	15F209	STUD, pull, trigger	1
119l	17J145	ARM, holder, gun	1
119m*	15F750	KNOB, holder, gun	1
120	25A488	CABLE, gun, manual (includes 126, 151)	1
121	188135	GUIDE, cable	1
122	248157	GUN, flex, basic	1
128▲	16P136	LABEL, safety, warning, iso	1
145	245733	KIT, repair, trigger handle (includes 132, 137, 138, 139)	1
151	126111	RETAINER, circlip, external, 8mm	2
158	108471	KNOB, pronged	1
159	111145	KNOB, pronged	2
178	25A487	CABLE, gun, automatic (includes 151, 212, 213)	1
265	17J408	ARM, extension, third gun	1
280	17C043	LABEL, number "1"	1
	17C046	LABEL, number "2"	1



* Included in Gun Holder Repair Kit 287569

▲ Replacement safety labels, tags, and cards are available at no cost.

Gun Trigger

Ref	Part	Description	Qty
120	25A488	CABLE, gun, manual (includes 126, 151)	1
124	245798	HOSE, coupled 1/4" x 7'	1
126	15F624	NUT, cable, gun (knurled)	2
330	25A636	BRACKET, trigger w switch	1
330a	276907	BRACKET, magnet	1
330e	17J237	SWITCH, reed	1
331	198896	BLOCK, mounting	1
332	245676	HANDLE	1
333	198895	PLATE, lever, pivot	2
334	111017	BEARING, flange	2
335	116941	SCREW, shoulder, skt hd	1
336	116969	NUT, lock	1
337	112381	SCREW, mach, pan head	1
338	117268	BRACKET, interrupter	1
339	117269	SPRING	1
340	128803	SCREW, thd forming, hex washer	1
342	117317	SCREW, plastine, pan head	2
344	17K587	LABEL, notice, adjustment	1

Parts Drawing - ES 2000

-  Torque to 18-22 in-lbs
(2.0-2.4 N·m)
-  Torque to 28-32 in-lbs
(3.1-3.6 N·m)
-  Torque to 45-55 ft-lbs
(61.0-74.5 N·m)

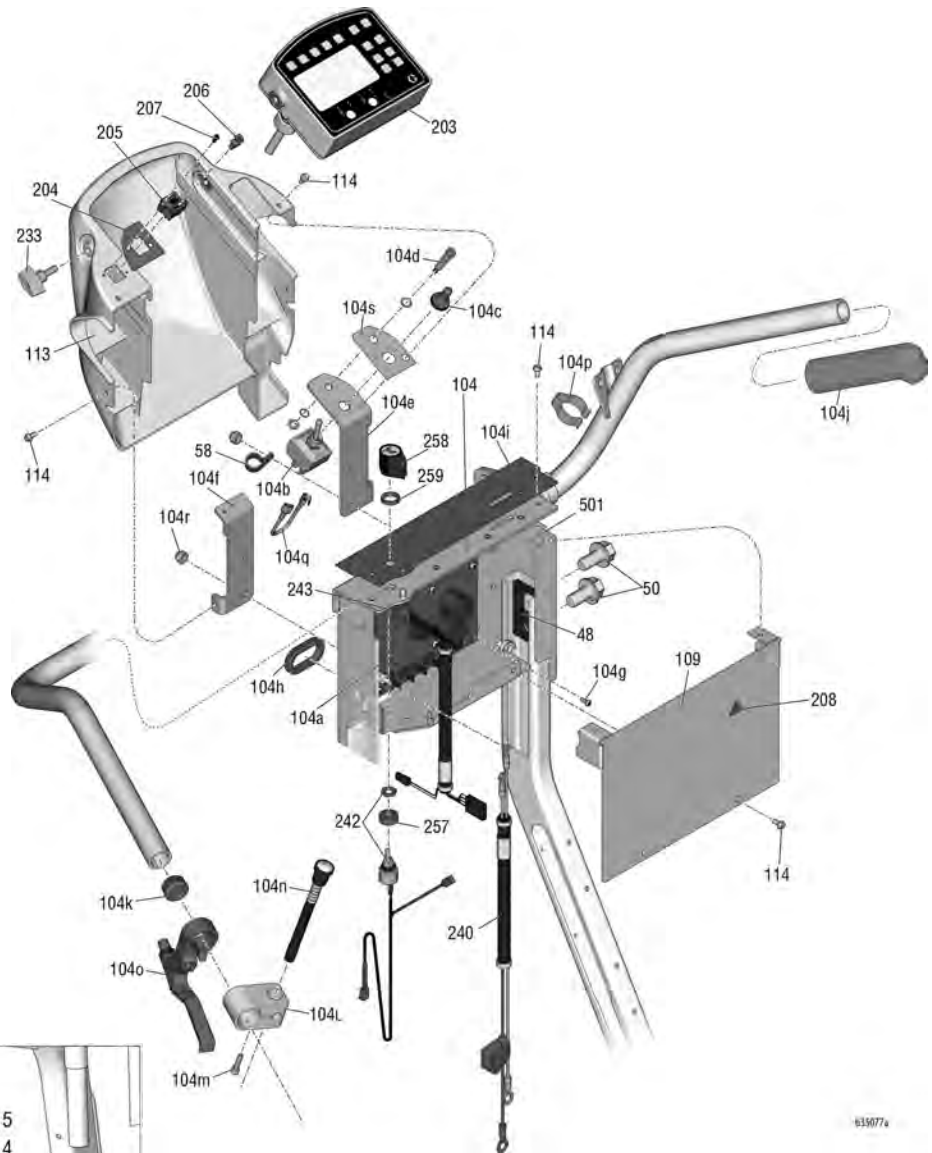

635077a

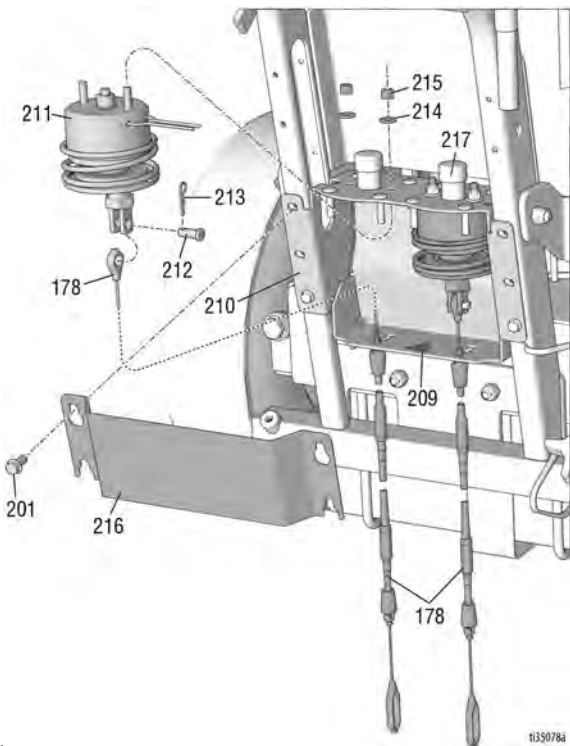

635078a

Parts List - ES 2000

Ref.	Part	Description	Qty	Ref.	Part	Description	Qty
48	17J125	BRACKET, slide	2	178	25A487	KIT, repair, gun cable, auto	2
50	17J136	SCREW, hex, flange hd	4	201	107257	SCREW, thd forming	6
58	113491	CLAMP, wire	1	203	25N791	BOX, control assy	1
104		CONTROL, auto, assembly	1	204	17V520	LABEL, USB	1
104a	25N788	KIT, repair, main board (standard)	1	205	17Z084	BOARD, assy, USB (includes 204, 206, 207)	1
	25N789	KIT, repair, main board (HP Auto)	1	206	131718	COVER, dust, USB	2
104b	131716	SWITCH, toggle, 3 PST	1	207	17V519	SCREW, pan head, #4-40 x 5/16"	2
104c	131717	BOOT, toggle	1	208	189930	LABEL, caution	1
104d	17N435	INDICATOR, LED	1	209	15H108	LABEL, safety, warning, pinch	1
104e	17N419	BRACKET, switch	1	210	24Y777	BRACKET, solenoid, weldment	1
104f	17J126	BRACKET, shroud	1	211	25A486	KIT, repair, solenoid	2
104g	120593	SCREW, mach	4	212	128711	PIN, clevis, 5/16 dia.	2
104h	17H701	GROMMET, oval	1	213	15R598	CLIP, cotter, hairpin	2
104i	25E273	LABEL, instructions	1	214	110755	WASHER, plain	4
104j	114659	GRIP, handle	2	215	121114	NUT, hex, self locking	4
104k	120151	PLUG, tube	2	216	17H650	COVER, solenoid	1
104l	15K162	BLOCK	1	217	128712	CAP, round, vinyl	2
104m	C20004	SCREW, cap	1	233	16W408	KNOB, t-handle, 1/4-20 thd stud	2
104n	17J236	SWITCH, push button	1	240	17Y064	HARNESS, wiring, battery, HP auto	1
104o	194310	LEVER, actuator	1	242	17Y142	POTENTIOMETER	1
104p	178342	CLIP, spring	4	243	17X979	HARNESS, wiring, wheel/pump	1
104q	17X957	WIRE, jumper	1	257	198650	SPACER, shaft	1
104r	102040	NUT, lock hex	4	258	116167	KNOB, potentiometer	1
104s	17N632	LABEL, switch	1	259	15C973	GASKET	1
109	17J123	PLATE, cover	1	501	24Y642	PLATE, control, Weldment	1
113	17J135	COVER, control (Standard units)	1				
	17U517	COVER, control (HP Auto units)	1				
114	128978	SCREW, mach, slot hex wash hd	8				

Distance Sensor Replacement (ES 2000)

1. Remove wheel (17) from LineLazer.
2. Remove screw (199), wire clamp (200) and distance sensor (198).
3. Roll o-ring (266) onto distance sensor (198), then install using wire clamp (200) and screw (199).
4. Install wheel (17) on LineLazer.

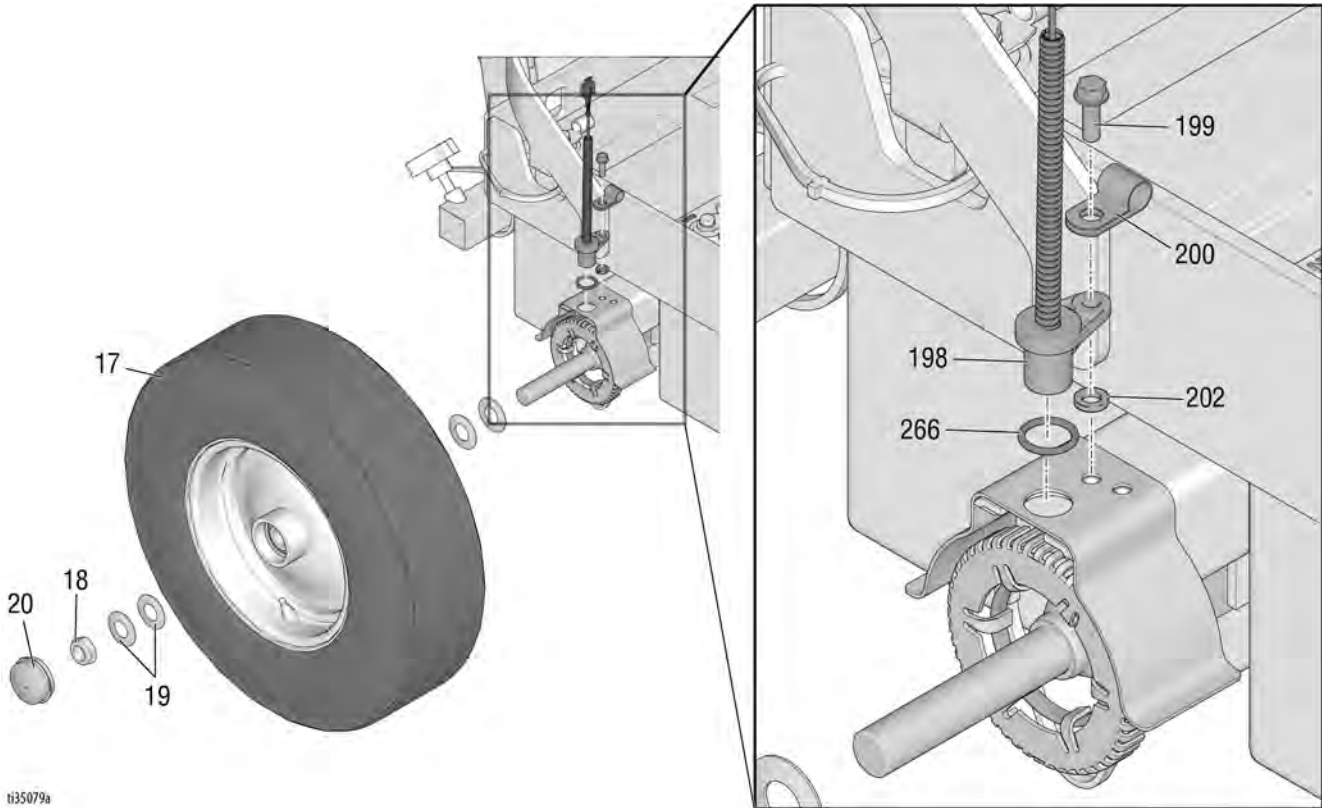

Wiring Diagram - 120V (ES 2000)

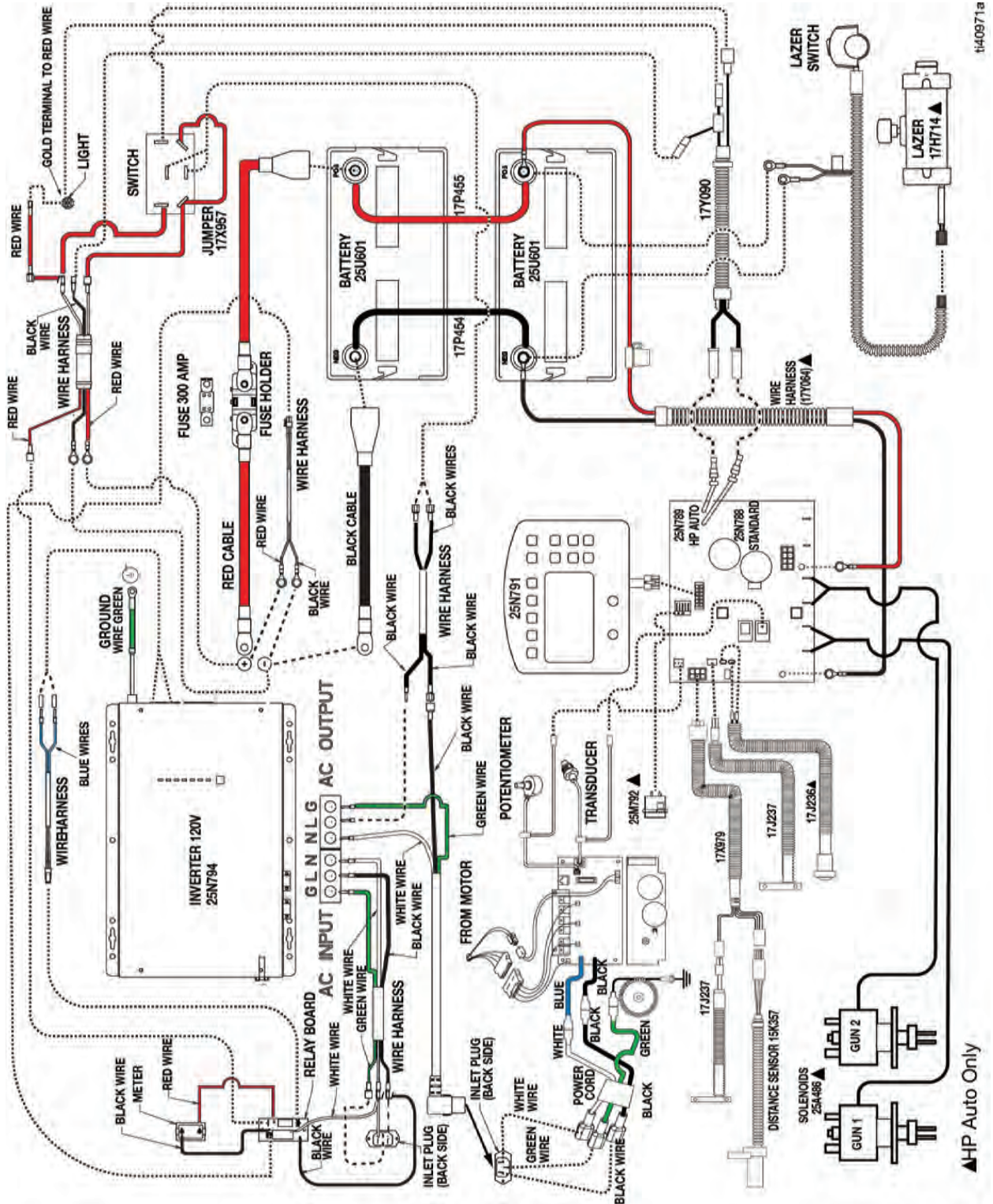

Control Board Wiring Diagram

110/120V (ES 2000)

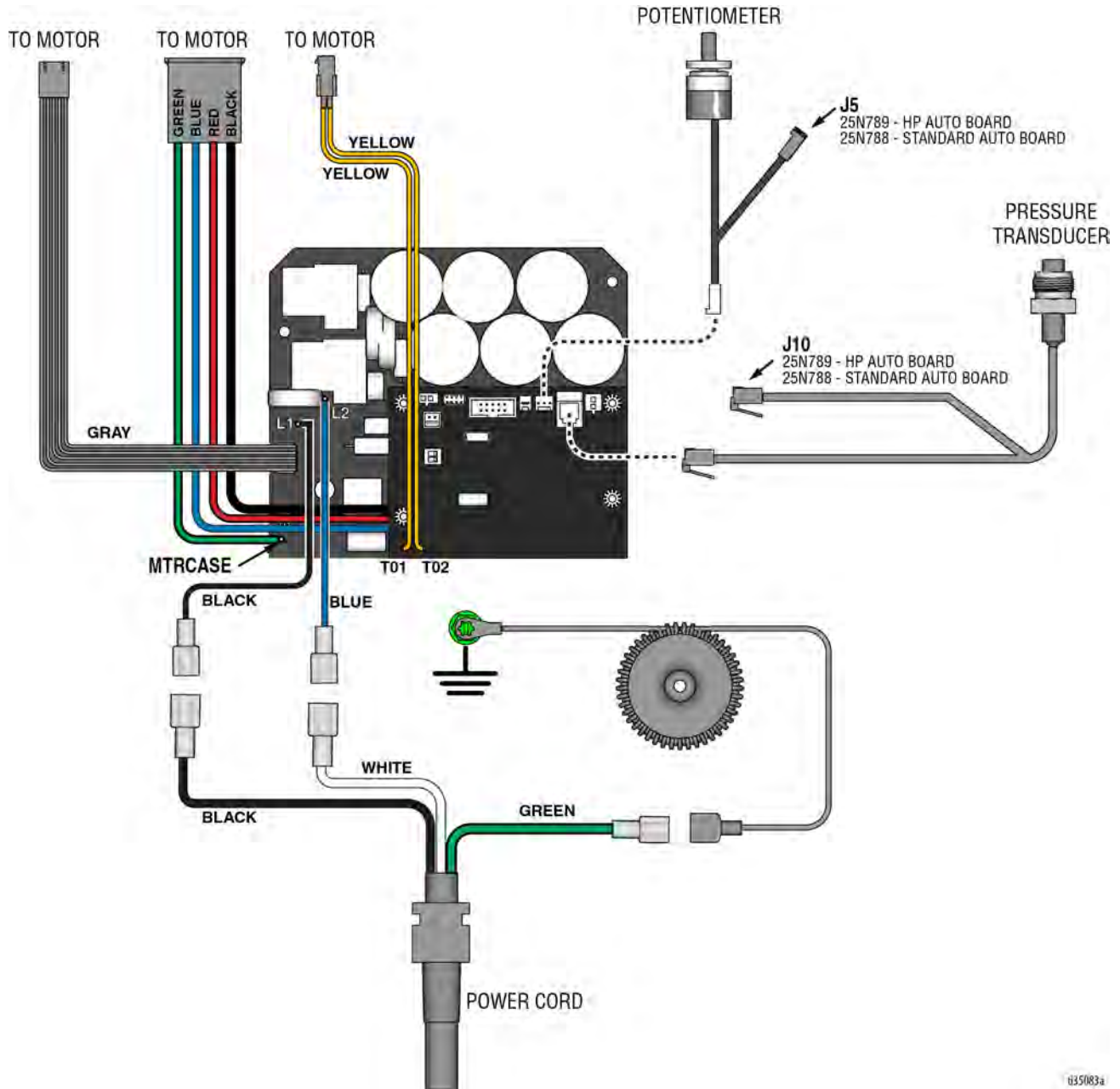

230V (ES 2000)

NOTICE

Heat from inductor coil of filter board may destroy wire insulation that comes in contact with it. Exposed wires could cause shorts and component damage. Bundle and tie loose wires so none lay in contact with inductor coil on the filter board.

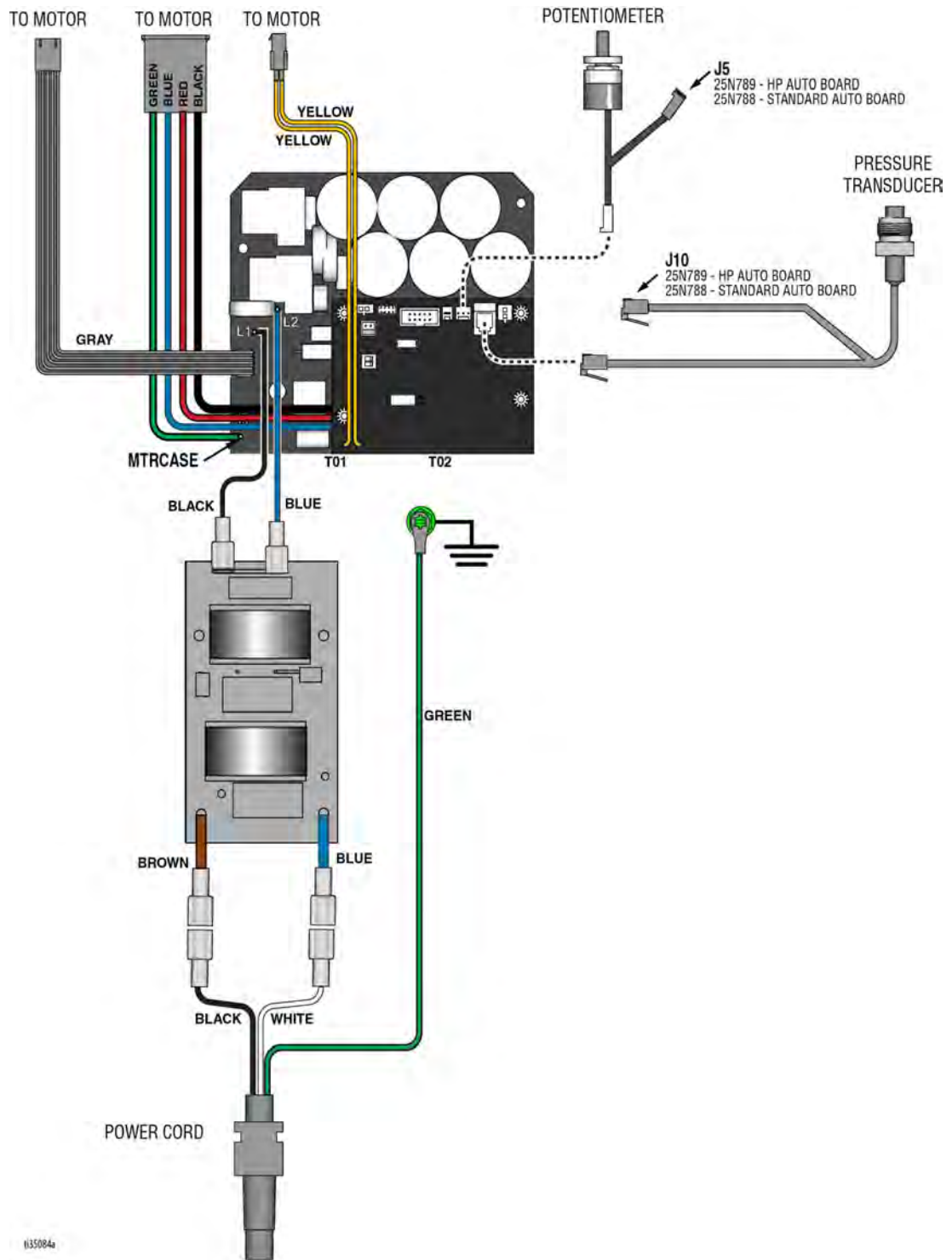

Wiring Diagram - 230V (ES 2000)

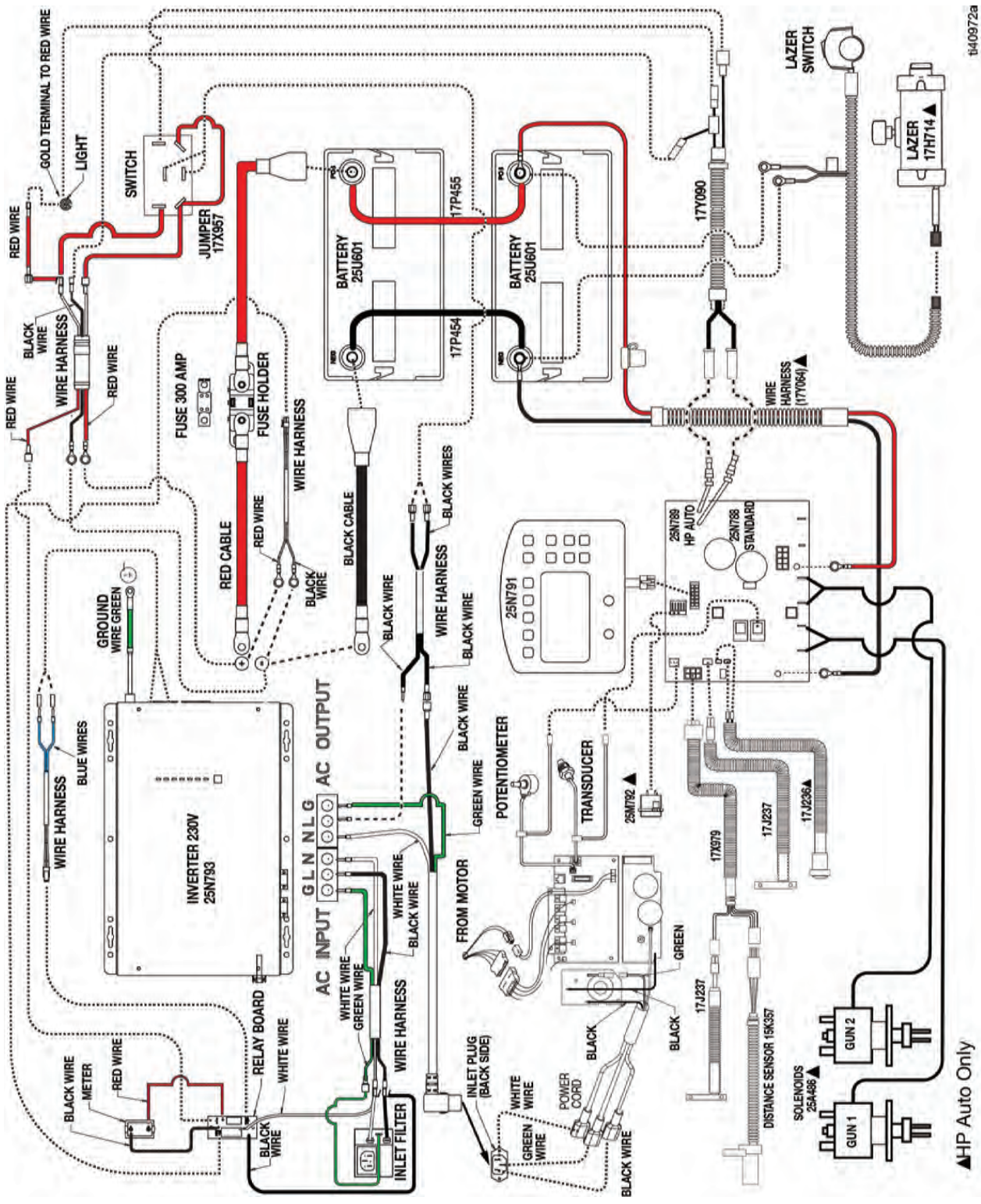

World Key Symbol

LLV GLOBAL SYMBOL KEY MENU SCREENS

STRIPING MODE	MEASURE MODE	LAYOUT MODE	SETTINGS/DATA	DATA LOGGING
<p>MANUAL, SEMI-AUTOMATIC or AUTOMATIC MODE</p> <p>PRESSURE</p> <p>GALLONS/LITERS</p> <p>LINE THICKNESS</p> <p>PAINT LENGTH</p> <p>SPACE LENGTH</p> <p>LINE WIDTH</p> <p>EXIT</p> <p>YELLOW</p> <p>WHITE</p> <p>BLACK</p> <p>BLUE</p> <p>GREEN</p> <p>RED</p> <p>BATTERY LOW</p> <p>BATTERY CHARGING</p>	<p>1 2 3 4 5 6 7 8 9 10</p> <p>PRESS TO START/STOP</p> <p>HOLD TO SPRAY A DOT</p>	<p>STALL CALCULATOR</p> <p>ANGLE CALCULATOR</p> <p>STALL WIDTH</p> <p>DOT SIZE SELECTOR</p>	<p>CALIBRATE</p> <p>SETTINGS</p> <p>UNITS</p> <p>INFORMATION & LIFE DATA</p> <p>MARKER LAYOUT MODE</p> <p>GUN SETTINGS</p> <p>SPECIFIC GRAVITY</p> <p>ENGINE HOURS</p> <p>TOTAL DISTANCE</p> <p>TOTAL GALLONS</p> <p>SOFTWARE REV</p> <p>ERROR CODES</p> <p>CONTRAST</p> <p>DIAGNOSTICS</p> <p>TIME AND DATE</p> <p>LOW SPEED SHUTOFF</p>	<p>START RECORDING NEW JOB</p> <p>JOBS</p> <p>TIME STAMP</p> <p>SCROLL</p> <p>DELETE</p> <p>DISTANCE PAINTED</p> <p>GALLONS OF LINE PAINTED</p> <p>GALLONS OF STENCIL PAINTED</p> <p>TIME AND DATE</p> <p>TOTALGALLONS/LITERS</p>

1128025a

Technical Specifications

LineLazer ES 1000 Lithium		
	U.S.	Metric
Dimensions		
Height (with handle bar down)	Unpackaged - 44.5 in. Packaged - 53.0 in.	Unpackaged - 113.03 cm Packaged - 134.62 cm
Width	Unpackaged - 34.25 in. Packaged - 39.0 in.	Unpackaged - 86.99 cm Packaged - 99.06 cm
Length	Unpackaged - 68.75 in. Packaged - 75.0 in.	Unpackaged - 174.63 cm Packaged - 190.5 cm
Weight (dry - no paint)	Unpackaged - 340 lbs Packaged - 437lbs	Unpackaged - 154 kg Packaged - 198 kg
Noise (dBA) Vibration (m/s²) (8 hours daily exposure)		
Sound Power per ISO 3741:	89.8 dBA	
Sound Pressure per ISO 3741:	85.3 dBA	
Vibration (m/s²) (8 hours daily exposure)		
Right-hand (per ISO 5349)	1.85	
Left-hand (per ISO 5349)	0.90	
Maximum Delivery	0.6 gpm	2.3 lpm
Maximum Tip Size 1 gun	.025	
Inlet paint strainer	16 mesh	1190 micron
Outlet paint strainer	60 mesh	297 micron
Pump inlet size	1 in. NSPM (m)	
Pump outlet size	1/4 NPT (f)	
Maximum working pressure	3300 psi	228 bar, 22.8 MPa
Materials of Construction		
Wetted materials on all models	PTFE, Nylon, polyurethane, V-Max, UHMWPE, fluoroelastomer, acetal, leather, tungsten carbide, stainless steel, chrome plating, nickel-plated carbon steel, ceramic	

LineLazer ES 2000 Lithium		
	U.S.	Metric
Dimensions		
Height (with handle bar down)	Unpackaged - 44.5 in. Packaged - 53.0 in.	Unpackaged - 113.03 cm Packaged - 134.62 cm
Width	Unpackaged - 34.25 in. Packaged - 39.0 in.	Unpackaged - 86.99 cm Packaged - 99.06 cm
Length	Unpackaged - 68.75 in. Packaged - 75.0 in.	Unpackaged - 174.63 cm Packaged - 190.5 cm
Weight (dry - no paint)	Unpackaged - 481 lbs Packaged - 578 lbs	Unpackaged - 218 kg Packaged - 262 kg
Noise (dBa)		
Sound Power per ISO 3744 (@ 3.1 ft):	91.0 dBA	
Sound Pressure per ISO 3744 (@ 3.1 ft):	82.0 dBA	
Vibration (m/s²) (8 hours daily exposure)		
Right-hand (per ISO 5349)	0.631	
Left-hand (per ISO 5349)	0.781	
Maximum Delivery	1.1 gpm	4.2 lpm
Maximum Tip Size 1 gun	.033	
Inlet paint strainer	16 mesh	1190 micron
Outlet paint strainer	50 mesh	297 micron
Pump inlet size	1 in. NSPM (m)	
Pump outlet size	3/8 NPT (f)	
Maximum working pressure	3300 psi	228 bar, 22.8 MPa
Materials of Construction		
Wetted materials on all models	PTFE, Nylon, polyurethane, V-Max, UHMWPE, fluoroelastomer, acetal, leather, tungsten carbide, stainless steel, chrome plating, nickel-plated carbon steel, ceramic	

LineLazer ES 1000 Lithium & ES 2000 Lithium (All Models)		
DC Input		
Nominal Input Voltage	12.0Vdc	
Minimum Start Voltage	10.0Vdc	
Low Battery Alarm	11.0Vdc	
Low Battery Trip	10.5Vdc	
High Voltage Alarm & Fault	16.0Vdc	
High DC Input Recovery	15.5Vdc	
Low Battery Voltage Recovery	13.0Vdc	
Idle Consumption-Search Mode	60W	
Charge		
Input Voltage Range	100~135VAC / 194~243 VAC;	
Input Frequency Range	50/60Hz	
Output Voltage	Depends on battery type (see chart below)	
Charger Breaker Rating (230Vac)	10A	
Charger Breaker Rating (120Vac)	20A	
Max Charger Rate	30 amps	
Over Charge Protection	15.7V for 12Vdc	
Battery Type	Fast Vdc	Float Vdc
Gel U.S.A.	14.0	13.7
Power Sonic Lithium (Graco Supplied)	14.1	13.4
A.G.M 2	14.6	13.7
Sealed Lead Acid	14.4	13.6
Gel Euro	14.4	13.8
Open Lead Acid	14.8	13.3
LiFePO4	14.4	14.4
De-sulphation	15.5 (4 hrs then OFF)	
Bypass & Protection		
Nominal Voltage	120Vac	230Vac
Low Voltage Trip	90V±4%	184V±4%
Low Voltage re engage	100V±4%	194V±4%
High Voltage Trip	140V±4%	253V±4%
High Voltage re engage	135V±4%	243V±4%
Max Input AC Voltage	150VAC	270VAC
Nominal Input Frequency	50Hz or 60Hz (Auto detect)	
Low Freq Trip	Wide: 40±0.3Hz for 50Hz/60Hz	
Low Freq re engage	Wide: 45±0.3Hz for 50Hz/60Hz	
High Freq Trip	Wide: No up limit for 50Hz/60Hz	
High Freq re engage	Wide: No up limit for 50Hz/60Hz	
Output Short circuit protection	Circuit Breaker	
Bypass Breaker Rating (230Vac)	20A	
Bypass Breaker Rating (120Vac)	30A	

LineLazer ES 1000 Lithium & ES 2000 Lithium (All Models)		
Batteries		
Nominal Battery Pack Voltage	12 VDC	
Quantity	ES 1000: 1 or 2	ES 2000: 2
Type	Lithium (LiPO4)	
Voltage (Nominal)	12 VDC	
Dimensions	12.99" x 6.73" x 8.46"	330 mm x 171 mm x 220 mm
Capacity (Nominal, 20hr rate)	50 Amp-hour / battery	
Charging Current	27.1 ADC	
Battery Temperature		
Operating	14-140°F	-10-60°C
Charging	32-113°F	0-45°C
Storing	32-113°F	0-45°C
All trademarks or registered trademarks are the property of their respective owners.		

California Proposition 65

CALIFORNIA RESIDENTS

 **WARNING:** Cancer and reproductive harm – www.P65warnings.ca.gov.

Graco Standard Warranty

Graco warrants all equipment referenced in this document which is manufactured by Graco and bearing its name to be free from defects in material and workmanship on the date of sale to the original purchaser for use. With the exception of any special, extended, or limited warranty published by Graco, Graco will, for a period of twelve months from the date of sale, repair or replace any part of the equipment determined by Graco to be defective. This warranty applies only when the equipment is installed, operated and maintained in accordance with Graco's written recommendations.

This warranty does not cover, and Graco shall not be liable for general wear and tear, or any malfunction, damage or wear caused by faulty installation, misapplication, abrasion, corrosion, inadequate or improper maintenance, negligence, accident, tampering, or substitution of non-Graco component parts. Nor shall Graco be liable for malfunction, damage or wear caused by the incompatibility of Graco equipment with structures, accessories, equipment or materials not supplied by Graco, or the improper design, manufacture, installation, operation or maintenance of structures, accessories, equipment or materials not supplied by Graco.

This warranty is conditioned upon the prepaid return of the equipment claimed to be defective to an authorized Graco distributor for verification of the claimed defect. If the claimed defect is verified, Graco will repair or replace free of charge any defective parts. The equipment will be returned to the original purchaser transportation prepaid. If inspection of the equipment does not disclose any defect in material or workmanship, repairs will be made at a reasonable charge, which charges may include the costs of parts, labor, and transportation.

THIS WARRANTY IS EXCLUSIVE, AND IS IN LIEU OF ANY OTHER WARRANTIES, EXPRESS OR IMPLIED, INCLUDING BUT NOT LIMITED TO WARRANTY OF MERCHANTABILITY OR WARRANTY OF FITNESS FOR A PARTICULAR PURPOSE.

Graco's sole obligation and buyer's sole remedy for any breach of warranty shall be as set forth above. The buyer agrees that no other remedy (including, but not limited to, incidental or consequential damages for lost profits, lost sales, injury to person or property, or any other incidental or consequential loss) shall be available. Any action for breach of warranty must be brought within two (2) years of the date of sale.

GRACO MAKES NO WARRANTY, AND DISCLAIMS ALL IMPLIED WARRANTIES OF MERCHANTABILITY AND FITNESS FOR A PARTICULAR PURPOSE, IN CONNECTION WITH ACCESSORIES, EQUIPMENT, MATERIALS OR COMPONENTS SOLD BUT NOT MANUFACTURED BY GRACO. These items sold, but not manufactured by Graco (such as electric motors, switches, hose, etc.), are subject to the warranty, if any, of their manufacturer. Graco will provide purchaser with reasonable assistance in making any claim for breach of these warranties.

In no event will Graco be liable for indirect, incidental, special or consequential damages resulting from Graco supplying equipment hereunder, or the furnishing, performance, or use of any products or other goods sold hereto, whether due to a breach of contract, breach of warranty, the negligence of Graco, or otherwise.

Graco Information

For the latest information about Graco products, visit www.graco.com.

For patent information, see www.graco.com/patents.

TO PLACE AN ORDER, contact your Graco distributor or call 1-800-690-2894 to identify the nearest distributor.

*All written and visual data contained in this document reflects the latest product information available at the time of publication.
Graco reserves the right to make changes at any time without notice.*

Original instructions. This manual contains English. MM 3A9033

Graco Headquarters: Minneapolis

International Offices: Belgium, China, Japan, Korea

GRACO INC. AND SUBSIDIARIES • P.O. BOX 1441 • MINNEAPOLIS MN 55440-1441 • USA
Copyright 2021, Graco Inc. All Graco manufacturing locations are registered to ISO 9001.

www.graco.com
Revision A, January 2022