

Operator's Manual

Utility Track Loader

SM100



This Operator's Manual includes
the AEM Safety Manual



Machine Type
Material Number
Version
Date
Language

UTL
5100064108 / 3300031444
04
08/2022
[en-US]



Imprint

Publisher and copyright holder:

Wacker Neuson America Corporation
N92W15000 Anthony Ave
Menomonee Falls, WI 53051, USA

www.wackerneuson.us

Original operator's manual

All rights reserved, in particular the copyright, the right of reproduction and the right of distribution applicable worldwide.

This document may be used by the recipient only for the designated purpose. It may in no way be duplicated or translated in any other language, in whole or in part, without prior permission in writing from the manufacturer.

Reproduction or translation of this publication, in whole or part, is not permitted without the written consent of Wacker Neuson America Corporation.

Violations of legal regulations, in particular of the copyright protection, will be subject to civil and criminal prosecution.

Wacker Neuson America Corporation reserves the right to change its products and their technical specifications for further technical development at any time without any claim to changes to machines already delivered. The information in the technical documentation supplied with the product applies in each case.

The machine on the cover is for illustration purposes only and may therefore have special equipment (options).

Wacker Neuson America Corporation, responsibility for errors or omissions not accepted, printed in USA
Copyright © 2022

California Proposition 65 Warning



⚠ WARNING

The engine exhaust from this product contains chemicals known to the State of California to cause cancer, birth defects, or other reproductive harm.



⚠ WARNING

Diesel engine exhaust and some of its constituents are known to the State of California to cause cancer, birth defects, and other reproductive harm.



⚠ WARNING

Cancer and Reproductive Harm
www.P65Warnings.ca.gov



⚠ WARNING

Batteries, battery posts, terminals and related accessories contain lead and lead compounds, and other chemicals known to the State of California to cause cancer and birth defects or other reproductive harm. WASH HANDS AFTER HANDLING.



This page is intentionally left blank.

Table of Contents

1	Foreword	
1.1	Information on This Operator's Manual.....	8
1.2	Machine Reference Information.....	8
1.3	Machine Documentation.....	9
1.4	Expectations for Information in This Manual.....	9
1.5	Manufacturer's Approval.....	9
1.6	Abbreviations.....	11
1.7	Maintenance Items.....	11
2	Usage	
2.1	Intended Use.....	12
2.2	Unintended Use.....	12
2.3	Residual Risks.....	13
3	Safety	
3.1	Signal Words Used in This Manual.....	14
3.2	Safety Guidelines for Operating the Machine.....	14
3.3	Safety Guidelines for Attachments.....	18
3.4	Safety Guidelines for Maintenance.....	19
3.5	Safety Guidelines for the Engine Control Unit (ECU).....	20
3.6	Special Hazards.....	20
3.7	Safety Guidelines when Using Internal Combustion Engines.....	21
3.8	Disposal.....	21
4	Vehicle Description	
4.1	Machine Description.....	22
4.2	Machine Overview.....	23
4.3	Labels Overview.....	24
4.4	Safety Labels.....	26
4.5	Information Labels.....	29
5	Transportation	
5.1	Preparing the Machine for Transportation.....	32
5.2	Loading and Unloading the Machine.....	32
5.3	Towing the Machine.....	33
6	Operation	
6.1	Risk of Injury or Death.....	35
6.2	Inspecting the Work Area.....	36
6.3	Break-In Period.....	36
6.4	Operation Checklists.....	37
6.5	Machine Controls.....	38

6.6	Control Interlock System	39
6.7	Starting and Stopping the Engine	40
6.8	Operating the Machine in Extreme Weather Temperatures	42
6.9	Instrument Display	44
6.10	Instrument Display Symbols and Functions	46
6.11	Instrument Display Subpages Menus	48
6.12	Machine Status Screens	49
6.13	Machine Options	50
6.14	Machine Vitals	50
6.15	Instrument Display Settings	51
6.16	Auxiliary Override	52
6.17	Adjusting the Operator Platform	52
6.18	Ground Drive and Loader Controls	53
6.19	Operating on Slopes	56
6.20	Using the Manual Coupler	57
6.21	Auxiliary Hydraulic Connections	60
6.22	Manual Auxiliary Controls	61
6.23	Filling and Dumping the Bucket	61
6.24	Recommended Fuels—Diesel and Biodiesel	62
6.25	Refueling the Machine	63
6.26	Lift Arm Manual Override	64
6.27	Lift Arm Support Device	65
6.28	Parking the Machine	66
7	Maintenance	
7.1	Maintenance	67
7.2	Maintenance Label	68
7.3	General Daily Checks	71
7.4	Operating the Hood	71
7.5	Lubrication Plan	72
7.6	Engine Oil Viscosity	74
7.7	Checking and Adding Engine Coolant	75
7.8	Checking the Hydraulic Oil Level	76
7.9	Testing the Control Interlock System	77
7.10	Checking for Leaks	78
7.11	Checking the Engine Oil	79
7.12	Draining and Cleaning the Water Separator	81
7.13	Checking the Exhaust System	82
7.14	Checking the Continuous Flow Shutoff System	83
7.15	Cleaning the Machine	84
7.16	Changing the Engine Oil and Filter	85

7.17	Checking and Adjusting the Drive Belts	87
7.18	Checking the Undercarriage	89
7.19	Inspecting Hoses and Hard Lines	89
7.20	Servicing the Air Cleaner	90
7.21	Checking and Cleaning the Radiator Fins	91
7.22	Checking and Adjusting Track Tension	92
7.23	Replacing the Fuel Filter	94
7.24	Replacing the Hydraulic Tank Filler Cap	96
7.25	Replacing the Hydraulic Fluid and Filter	96
7.26	Maintaining the Battery	98
7.27	Engine—Jump-starting	99
8	Troubleshooting	
8.1	Engine and Engine Oil Warning Lights	103
8.2	Diagnostic Trouble Codes	103
9	Shutdown	
9.1	Long-Term Storage	107
9.2	Machine Disposal and Decommissioning	108
10	Technical Data	
10.1	Engine	109
10.2	Machine Speeds	109
10.3	Fluids	110
10.4	Electrical System	111
10.5	Hydraulic System	111
10.6	Drive System	111
10.7	Controls	111
10.8	Forces	112
10.9	Weights and Ground Pressure	112
10.10	Tightening Torques	113
10.11	Dimensions	114
11	Emission Control Systems Information and Warranty—Diesel	
11.1	Emission Control System Background Information	115
11.2	Limited Defect Warranty for Exhaust Emission Control System	116
11.3	Limited Defect Warranty for Wacker Neuson Emission Control Systems	116
11.4	Yanmar Limited Warranty	118
11.5	Yanmar Power Technology Co., Ltd. Emission Control System Warranty—USA Only	120
12	Compact Tool Carrier AEM Safety Manual	
	Index	148

1 Foreword

1.1 Information on This Operator's Manual

The canister for storing the operator's manual is located on the underside of the hood.

1.2 Machine Reference Information

The following machines and variants/options are described:

Machine	Item Number
SM100	1000423340, 1000494879

Machine identification

A nameplate listing the model number, item number, and serial number is attached to this machine. The location of the nameplate is shown below.

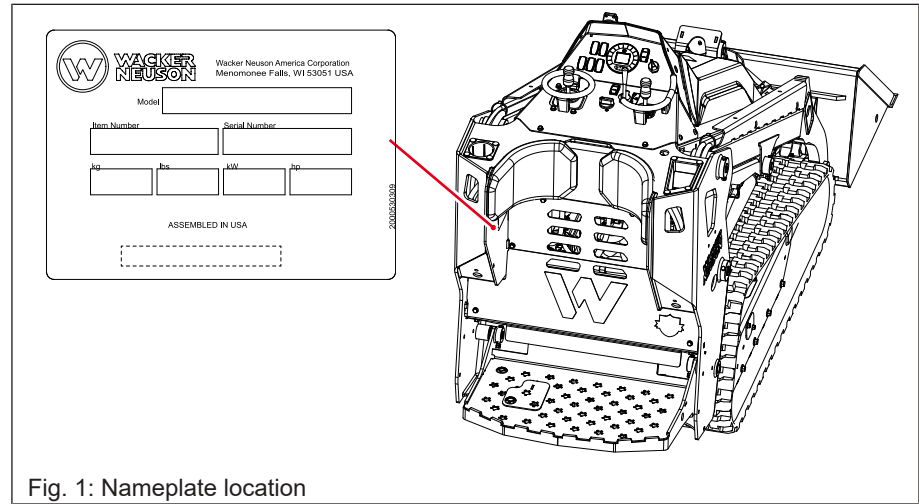

Fig. 1: Nameplate location

Engine nameplate

The engine nameplate identifies the model, displacement, and engine number. The location of the engine nameplate is shown below.

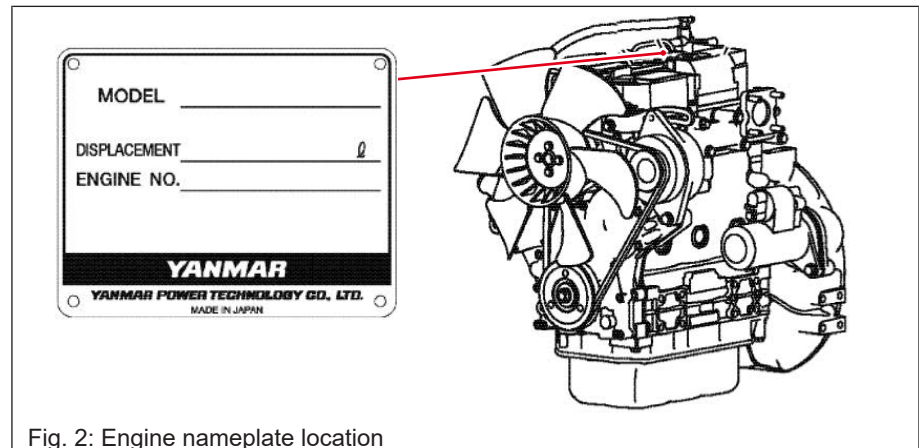

Fig. 2: Engine nameplate location

Write the machine information for your machine on this page. Provide these numbers to your dealer when you need service parts or information about your machine.

Machine model	
Machine item number	
Machine serial number	
Engine serial number	
Wacker Neuson dealer	
Address	
Phone number	

1.3 Machine Documentation

Keep a copy of the operator’s manual with the machine at all times.

From this point forward in this documentation, Wacker Neuson America Corporation will be referred to as Wacker Neuson or the manufacturer.

For spare parts information, please see your Wacker Neuson dealer, or visit the Wacker Neuson website at <http://www.wackerneuson.com/>.

When ordering parts or requesting service information, be prepared to provide the machine model number, item number, and serial number.

1.4 Expectations for Information in This Manual

This manual provides information and procedures to safely operate and maintain this machine. For your own safety and to reduce the risk of injury, carefully read, understand, and observe all instructions described in this manual.

The manufacturer expressly reserves the right to make technical modifications, even without notice, which improve the performance or safety standards of its machines.

The information contained in this manual is based on machines manufactured up until the time of publication. The manufacturer reserves the right to change any portion of this information without notice.

The illustrations, parts, and procedures in this manual refer to the manufacturer’s factory-installed components. Your machine may vary depending on the requirements of your specific region.

This operator’s manual does not include information on attachments.

Please contact your dealer if you require more information on the machine or the operator’s manual.

1.5 Manufacturer's Approval

This manual contains references to approved parts, attachments, and modifications. The following definitions apply:

- Approved parts or attachments are those either manufactured or provided by the manufacturer.
- Approved modifications are those performed by an authorized service center according to written instructions published by the manufacturer.
- Unapproved parts, attachments, and modifications are those that do not meet the approved criteria.

Unapproved parts, attachments, or modifications may have the following consequences:

- Serious injury hazards to the operator and persons in the work area
- Permanent damage to the machine which will not be covered under warranty

Contact your dealer immediately if you have questions about approved or unapproved parts, attachments, or modifications.

1.6 Abbreviations

Term	Definition
AUX	Auxiliary
DTC	Diagnostic trouble code
ECU	Engine control unit
EGR	Exhaust gas recirculation
FMI	Failure Mode Identifier
PEL	Permissible exposure limits
PPE	Personal protective equipment
ROC	Rated operating capacity
SMV	Slow moving vehicle
SPN	Suspect parameter number
STD	Standard (hydraulics)
ULSD	Ultra low sulfur diesel

1.7 Maintenance Items

Item	Part Number	Item	Part Number
Oil Filter	1000003052	Drive Belt	1000470869
Air Filter, Primary	1000467407	Fan Belt	1000466932
Air Filter, Secondary	1000467408	Battery	5000177257
Fuel Filter	1000466939	Coolant	5000157214
Fuel Water Separator	1000466934	Radiator Cap	1000431928
Hydraulic Oil Filter	1000463685	Fuel Cap	1000340135
Hydraulic Oil	5000164672	Hydraulic Tank Cap	1000340157
Tracks, Wide	1000421187	Hydraulic Tank Screen	1000340159
Grease	1000367563	—	—

2 Usage

2.1 Intended Use

In accordance with this designated use, the machine may only be used for moving earth, gravel, coarse gravel or ballast, and rubble. It may also be operated with approved attachments for additional applications.

No other applications are designated for the use of the machine. Wacker Neuson will not be liable for damage resulting from use other than mentioned above. The operator alone will bear the risk.

Designated use includes following the instructions set forth in the operator's manual and following the maintenance schedule.

Machine safety can be negatively affected by performing machine modifications without proper authority and by using spare parts, equipment, attachments, and optional equipment which have not been approved by Wacker Neuson. Wacker Neuson will not be liable for damage resulting from unapproved parts or unauthorized modifications.

Wacker Neuson shall not be liable for personal injury and/or damage to property caused by failure to follow the safety instructions on labels and in this operator's manual, or by not exercising due care when:

- Transporting the machine
- Operating the machine
- Servicing the machine and performing maintenance work
- Repairing the machine

2.2 Unintended Use

The machine shall not be used for transport jobs on public roads unless it is in compliance with applicable regulations.

Using this machine for any other purpose than described above could permanently damage the machine or seriously injure the operator or other persons in the area. Machine damage caused by misuse is not covered under warranty.

The following are some examples of misuse:

- Using the machine as a ladder, support, or work surface
- Using the machine to carry or transport passengers or equipment
- Using the machine to tow other machines
- Operating the machine outside of factory specifications
- Operating the machine in a manner inconsistent with all warnings found on the machine and in the operator's manual

2.3 Residual Risks



⚠ WARNING

Serious injury or death hazard

Improper operation of the machine can result in serious injury or death. Before operating this machine, make sure to:

- ▶ Read and understand the operator's manual.
- ▶ Read and understand all labels on the machine.
- ▶ Have training in the safe and proper use of the machine.
- ▶ Follow all applicable laws and regulations that pertain to this machine.

This machine has been designed and built in accordance with the latest global safety standards. It has been carefully engineered to eliminate hazards as far as practicable and to increase operator safety through protective guards and labeling. However, some risks may remain even after protective measures have been taken. They are called residual risks.

On this machine, residual risks can include exposure to:

- Heat, noise, exhaust, and carbon monoxide from the engine
- Burns from hot hydraulic oil or hot surfaces
- Fire hazards from improper refueling techniques
- Fuel and its fumes
- Personal injury from improper lifting techniques
- Crushing hazards from improper operation (feet, legs, or arms extending outside of the operator work station) and for other persons in the work zone

3 Safety

3.1 Signal Words Used in This Manual

This manual contains DANGER, WARNING, CAUTION, *NOTICE*, and NOTE signal words which must be followed to reduce the possibility of personal injury, damage to the equipment, or improper service.



⚠ DANGER

DANGER indicates a hazardous situation which, if not avoided, will result in death or serious injury.

- ▶ To avoid death or serious injury from this type of hazard, obey all safety messages that follow this signal word.



⚠ WARNING

WARNING indicates a hazardous situation which, if not avoided, could result in death or serious injury.

- ▶ To avoid possible death or serious injury from this type of hazard, obey all safety messages that follow this signal word.



⚠ CAUTION

CAUTION indicates a hazardous situation which, if not avoided, could result in minor or moderate injury.

- ▶ To avoid possible minor or moderate injury from this type of hazard, obey all safety messages that follow this signal word.



NOTICE

NOTICE identifies a situation that causes damage if it is not observed.

- ▶ To avoid possible damage from this type of hazard, obey all safety messages that follow this signal word.

Note: A Note contains additional information important to a procedure.

3.2 Safety Guidelines for Operating the Machine

Operator and service training, knowledge, and qualifications

Before operating, maintaining, or servicing the machine:

- Familiarize yourself with the location and proper use of all controls and safety devices.
- Know the rules for the jobsite.
- Contact Wacker Neuson for additional training if necessary.

When operating this machine:

- Do not allow improperly trained people to operate the machine.
- Do not operate the engine while wearing a headset to listen to music or radio because it will be difficult to hear the alert signals.
- People operating the machine must be familiar with the potential risks and hazards associated with it.
- Follow legal and other mandatory regulations relevant to accident prevention and environmental protection. These may include handling hazardous substances, issuing and/or wearing PPE, or obeying traffic regulations.

The machine must not be accessed or operated by:

- Children
- People impaired by alcohol, drugs, or prescription drugs
- People who are feeling ill

Jobsite



⚠ WARNING

Electric shock hazard

Electric shock can cause severe injury or death.

- ▶ Maintain a safe distance from overhead energized electric lines.

The operator and any people in the jobsite are at risk if the machine is not operated correctly. Know the rules for the jobsite, which include but are not limited to the following:

- Remain aware of changing positions and the movement of other equipment and personnel in the jobsite.
- Use extra care when operating over uneven ground, on hills, or over soft or coarse material. The machine could shift or slide unexpectedly.
- Use caution when operating the machine near the edges of pits, trenches, or platforms. Ensure the ground surface is stable enough to support the weight of the machine with operator and there is no danger of the machine sliding, falling or tipping.
- Do not operate the machine in areas that contain flammable objects, fuels, or products that produce flammable vapors.
- Do not place diesel fuel or other flammable material such as oil, hay, or dried grass close to the engine during engine operation or shortly after shutdown.
- Keep the area around the muffler free of debris such as leaves, paper, cartons, etc. A hot muffler could ignite the debris and start a fire.
- When operating the machine in contaminated areas, take appropriate measures to protect the operator and the machine.
- Familiarize yourself with the jobsite before beginning work, especially when operating in buildings or enclosed areas. Be aware of:
 - Obstacles in the operating and traveling area

- Any necessary barriers separating the jobsite from public roads
- Height of the ceiling/clearances
- Width of entrances
- Maximum load of ceilings and floors
- Sufficient room ventilation to reduce the risk of carbon monoxide poisoning
- Observe the risk zone.
- Be aware of overhead electric lines. If the machine touches an energized electric line:
 - Do not leave the machine until the energized electric line has either been de-energized or removed from the machine.
 - While the machine is touching the energized electric lines, warn others against approaching and touching the machine.
 - Move the machine away from the energized electric lines.
 - Have the energized electric lines de-energized.

Environmental conditions for operation

- Avoid operating in extremely dusty conditions.
- Avoid operating in the presence of chemical gases or fumes.
- Avoid operating in a corrosive atmosphere such as salt water spray.
- Do not expose the engine to the rain.
- When the engine is operated in dusty conditions, inspect the air cleaner element more frequently.
- Contact your authorized YANMAR industrial engine dealer or distributor if the engine will be operated at an altitude of 1,676 m (5,500 ft) or higher. High altitude reduces engine power, de-stabilizes operation and generates exhaust gas that exceeds the specification amount in design.

Dust precaution

- Work in a well ventilated area.
- Use a dust control system.
- Wear an approved dust/particle respirator.

Demolition or excavation work

- When working on roofs or similar structures, check the resistance and the structure itself before starting work. The building can collapse, causing serious injury, death, and damage.
- Do not place the machine directly under the workplace during demolition. Debris can fall onto the machine or the building can collapse, causing serious injury, death, and damage.
- Look out for hazards such as high-voltage lines, underground cables, buried utility lines (electrical, gas, water, communication, sewer), etc., during excavation work.

Before any digging begins:

- Contact the person responsible for jobsite utilities. Follow their recommendations for support and securing of utility lines.

Risk zone awareness

- The risk zone is the area in which persons are at risk due to the movements of the machine, work equipment, additional equipment, or material.
- Stop work immediately if persons do not leave the risk zone in spite of warnings.
- The risk zone also includes areas affected by falling material, equipment, or construction debris. For further information, [see Risk of Injury or Death on page 35](#).

Before machine operation

The machine, including all components, safety devices, labels, and attachments must be in good condition before use.

- If the machine is functioning unpredictably or in event of malfunctions, turn off the machine immediately, remove the key, and report the malfunction to a qualified technician or supervisor. Safety-relevant damage or malfunctions of the machine must be repaired immediately.

Machine operation

- When stepping on or off the operator platform, face the machine and use three points of contact.
- Keep the attachments or work equipment close to the ground. Keep the load low when moving on slopes—up, down, and across.
- Do not get on or off a moving machine, and do not jump off the machine.
- Remain aware of the machine's moving parts. Keep hands, feet, and loose clothing away from the machine's moving parts.
- Know the machine's lifting capacity. Do not exceed the ROC for the machine. For further information, [see Forces on page 112](#).
- Do not use a mobile device while operating this machine.
- Do not allow anyone underneath a raised load.
- Do not leave the machine running unattended.
- Do not operate the machine before it has reached its operating temperature.
- Do not consume the operating fluids used in this machine.
- Do not use the machine as a crane. These loaders are not approved for craning applications. These craning applications include raising, transporting, and lowering point loads with the help of slings and load-securing devices (for example, ropes and chains). This applies, for example, to lifting and lowering pipes, shaft rings or containers.

PPE

Wear the following PPE while operating this machine:

- Close-fitting work clothes that do not hinder movement
- Eye protection
- Hearing protection
- Safety-toed footwear

Tie back long hair and remove all jewelry (including rings).

Operator presence system

- This machine is equipped with an operator presence system that locks out machine operation when the operator has not engaged the operator presence pedal.
- Do not operate the machine when the operator presence system or any safety device is malfunctioning. Contact a Wacker Neuson dealer.
- Start and operate the machine from the operator platform only.

Traveling

- Before moving the machine, check whether the attachments have been safely attached.
- Adjust your travel speed to the road/ground conditions, machine handling, and to the visibility conditions.
- Look to the rear before moving the machine in reverse.
- In certain situations, use another person to direct movement of the machine on the jobsite safety.

3.3 Safety Guidelines for Attachments

Information regarding attachments

- Do not lift, lower, or transport people on the machine or in/on an attachment.
- Use approved attachments only. See your local Wacker Neuson dealer.
- Attachments and counterweights affect handling and the machine's steering capability.
- Lower the attachment to the ground before exiting the machine.

Installation and removal of attachments

- Follow attachment mounting instructions in this operator's manual.
- Before uncoupling or coupling an attachment with the hydraulic coupler:
 - Ensure the attachment is lowered to the ground and level.
 - Release the pressure in the auxiliary hydraulic system. For further information, [see Auxiliary Hydraulic Connections on page 60](#).
- Ensure the attachment is securely attached and that it functions correctly.
- Connect all hydraulic and electrical devices for the attachment and check their function before operating the machine.

- Secure the attachments against unintentional movement.
- Keep others away from the machine when installing or removing an attachment.

3.4 Safety Guidelines for Maintenance

General maintenance notes

- Follow all instructions in the Maintenance chapter of this operator's manual. For instructions on adjustment, maintenance, and inspection activities and intervals, [see Maintenance on page 67](#).
- Wacker Neuson requires the machine owner to have maintenance performed under all circumstances. Otherwise, the warranty shall not be given in full.
- For inspection and maintenance work, ensure all tools and service center equipment are capable of performing the tasks prescribed. Do not use malfunctioning or broken tools. Use certified measuring devices that are routinely calibrated for accuracy (for example torque wrench, pressure gauge, ammeter).
- Retighten any screws, electrical connections, or hose connections that may have been loosened during maintenance and repair.
- Recycle scrapped parts and drained fluids according to environmental and hazardous material requirements. To avoid fire and health hazards, dispose of soiled shop towels by approved methods.
- If any lockout/support devices are removed for setup, maintenance, or repair purposes, they must be refitted and checked immediately upon completion of the maintenance/repair work.

Service training

Before servicing or maintaining the machine, [see Safety Guidelines for Operating the Machine on page 14](#).

Replacing parts and labels

- Spare parts must comply with the technical requirements specified by Wacker Neuson. Contact your Wacker Neuson dealer for assistance.
- Replace worn or damaged components.
- Replace all missing and hard-to-read labels.
- When replacing electrical components, use components that are identical in rating and performance to the original components.
- When replacement parts are required for this machine, use only Wacker Neuson replacement parts or those parts equivalent to the original in all types of specifications, such as physical dimensions, type, strength, and material.

Cleaning and servicing

- Keep machine clean and free of debris such as leaves, paper, cartons, etc.
- Keep labels legible. When pressure washing decals, direct the stream at a 90 degree angle to the surface with the spray nozzle at least 12 inches away.
- Do not clean the machine while it is running.
- Never use gasoline or other types of fuels or flammable solvents to clean the machine. Fumes from fuels and solvents can become explosive.

3.5 Safety Guidelines for the Engine Control Unit (ECU)

- Never use the ECU for purposes that are not intended by YANMAR; such as using unauthorized ECU, writing unauthorized data to ECU, leaving it broken, or removing sensors and actuators. Doing so could result in the violation of emission control regulations and will void the product warranty.
- Be sure to use the ECU in conjunction with the engines whose models or serial numbers are specified by YANMAR. Other ECU/engine combinations than specified will void the engine warranty.
- Replacing the fuel injection pump involves rewriting the fuel injection data in the ECU. Be sure to contact your local YANMAR dealer before replacing the fuel injection pump. Failure to rewrite the fuel injection data before replacing the fuel injection pump will void the engine warranty.
- Replacing the ECU involves migrating the fuel injection data to the existing ECU to the new unit. Be sure to contact your local YANMAR dealer before replacing the ECU. Failure to migrate the fuel injection data before replacing the ECU will void the engine warranty.
- Improper use or misuse of the ECU may result in death or serious injury due to an abrupt and unexpected increase in engine speed.

3.6 Special Hazards

Electrical energy

- Use only fuses with the specified current rating.
- Stop the machine immediately if an electrical system malfunction occurs. Disconnect the battery and contact a trained technician to perform troubleshooting procedures.
- Regularly inspect the machine's electrical components. Immediately repair any defects such as loose connections, damaged or corroded connectors, or cracked or scorched cables.
- Attachments with electrical connections must be compatible with the machine's voltage specifications (12 volts).
- For specific safety precautions when working with batteries, [see Maintaining the Battery on page 98](#).

Hydraulics

The machine's hydraulic system can still be pressurized even when the engine is not running.

- Be careful operating the machine when the hydraulic oil is very cold. Proceed with caution even after the cold system restriction warning turns off. Cold hydraulic oil can still be present in certain circuits.
- Do not touch hydraulic components while the machine is operating. Wait until the machine is cool.
- Hydraulic oil is flammable. Stop the engine immediately if a hydraulic leak is detected.

3

3.7 Safety Guidelines when Using Internal Combustion Engines

Running the engine

- Check the fuel lines for leaks and cracks before starting the engine.
- Do not run the machine if fuel leaks are present or the fuel lines are loose.
- Engine exhaust can kill you in minutes. Engine exhaust contains carbon monoxide. Never run the machine indoors or in an enclosed area such as a deep trench unless there is adequate ventilation.
- Do not run the engine near open flames or in potentially explosive areas.
- Do not touch the engine or exhaust when the engine is running or immediately after it has been turned off.
- Do not operate a machine when its fuel cap is loose or missing.
- Do not remove the radiator cap when engine is running or hot. The radiator fluid is hot and under pressure, and can cause severe burns.

3.8 Disposal



Environment

The operating fluids in this machine, including fuel, engine oil, and grease, may be considered hazardous waste in many areas. Responsible disposal prevents toxic chemicals and materials from harming the environment. Follow the product-related safety regulations SDS (Safety Data Sheet – MSDS).

All fluids, lubricants, materials, etc., used on the machine are subject to specific regulations regarding collection and disposal. Dispose of different materials and consumables separately and responsibly in accordance with environmental protection legislation.

If the machine is no longer used according to its designated use, ensure it is decommissioned or put out of operation and disposed of according to applicable regulations.

- Follow all applicable safety regulations during machine disposal.
- Machine disposal must be performed in accordance with state-of-the-art standards that apply at the time of disposal.

4 Vehicle Description

4.1 Machine Description

The Wacker Neuson Utility Track Loaders are self-propelled work machines. These machines are versatile and powerful helpers for moving earth, gravel, and debris on construction sites and elsewhere. A wide range of attachments allow for numerous different applications of the machines in various environments. When using these attachments, observe the legal regulations of your country and equip the machine with all the safety equipment required.

4.2 Machine Overview

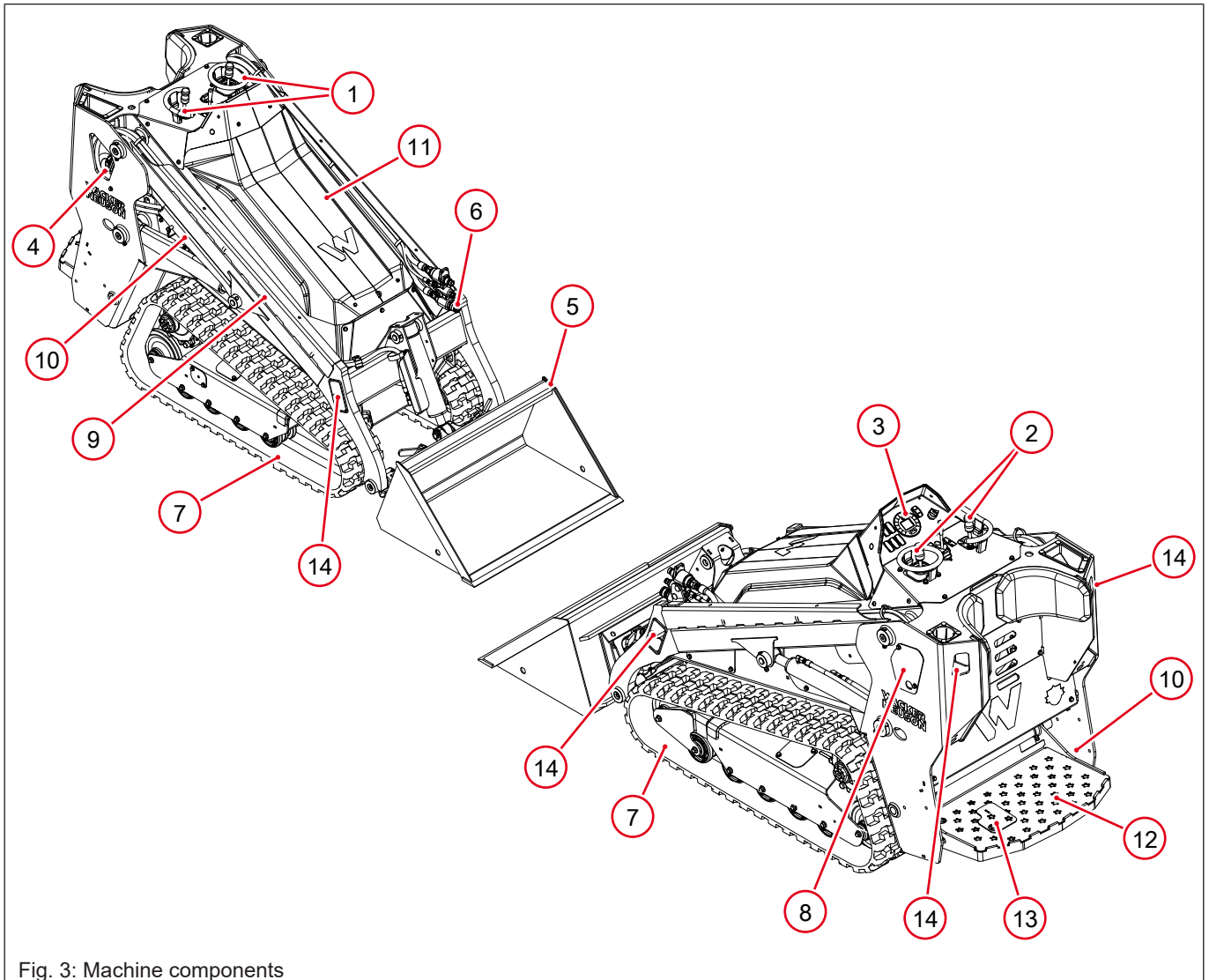
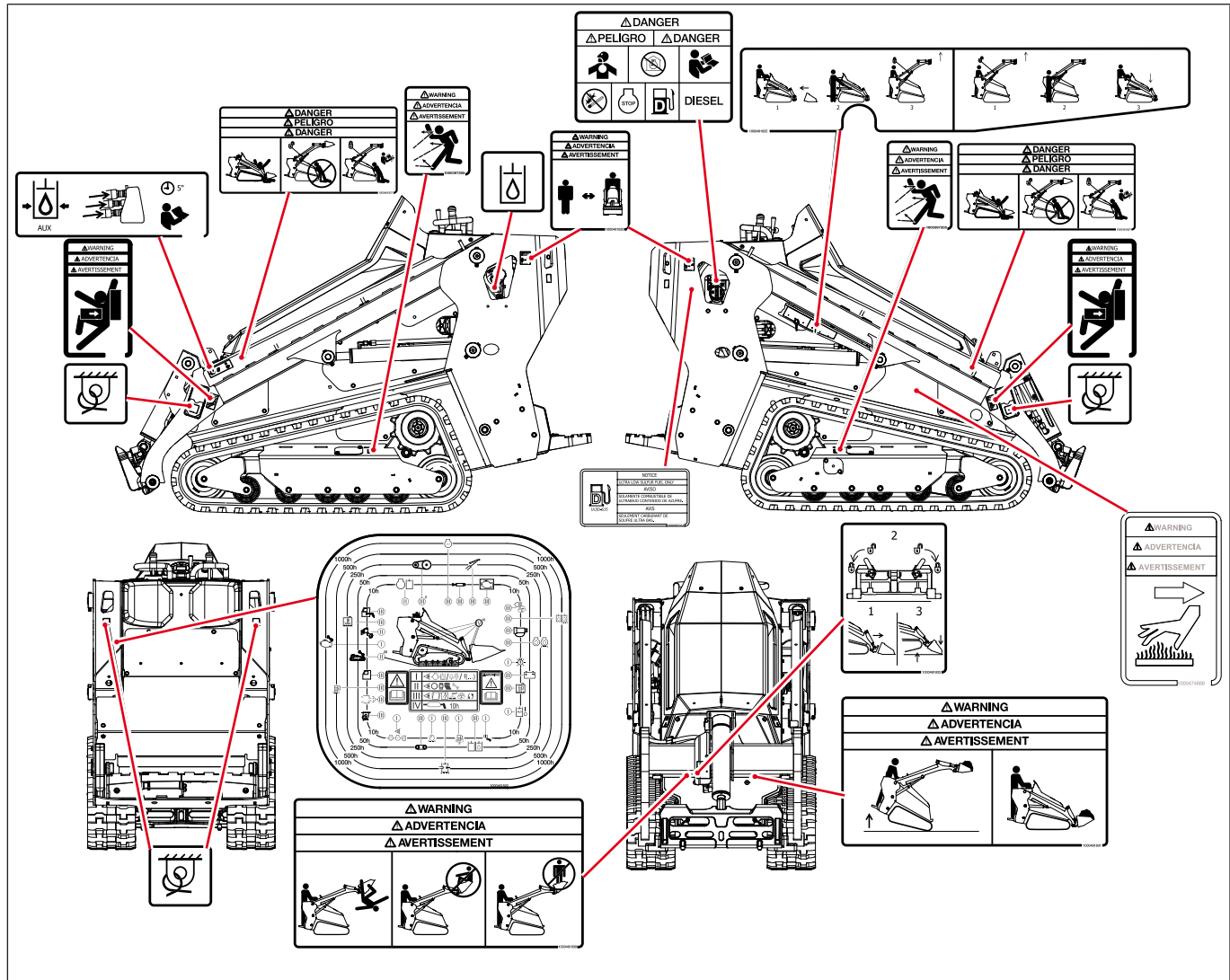

Fig. 3: Machine components

Ref.	Component	Ref.	Component
1	Handrails	2	Controls
3	Display	4	Diesel fuel fill
5	Attachment (options available)	6	Auxiliary hydraulic couplers
7	Tracks	8	Hydraulic oil fill
9	Lift arm	10	Lift arm support device
11	Hood	12	Operator platform
13	Operator presence pedal	14	Tie-down points

4.3 Labels Overview



4.4 Safety Labels



DANGER

Asphyxiation hazard

- Engines emit carbon monoxide.
- Do not run the machine indoors or in an enclosed area unless adequate ventilation, through such items as exhaust fans or hoses, is provided.
- Read the Operator's Manual.
- No sparks, flames, or burning objects near the machine.
- Stop the engine before refueling.
- Use only clean, filtered diesel fuel

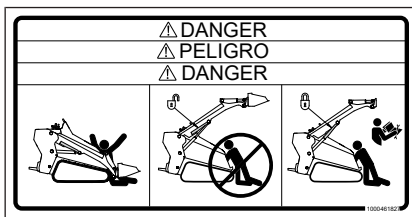

DANGER

Crushing hazard

Ensure lift arm support device is in place before working on raised lift arm. Do not work under a raised lift arm without securing the lift arm support device.



DANGER

Asphyxiation hazard

- Engines emit carbon monoxide.
- Do not run the machine indoors or in an enclosed area unless adequate ventilation, through such items as exhaust fans or hoses, is provided.
- Read and understand the supplied operator's manual before operating the machine. Failure to do so increases the risk of injury to yourself or others.



WARNING

Do not step off platform with load raised.

Keep heavy end uphill.

Travel up and down slopes not across them.

Never drive over obstructions.

Slow down on rough and uneven terrain.

Avoid abrupt starts and stops.

Operate only from operator's position.

Check for utility lines before digging.

Keep loads level when raising lift arms.

Look behind while backing up.

Check risk zone before turning.



WARNING

Injury hazard

Do not stand within 2 m (6.6 ft) of the machine.



WARNING

Keep door closed except for service.

Keep engine clean of flammable material.

Keep body, loose objects, and clothing away from electrical contacts, moving parts, hot parts, and exhaust.

Leaking fluids under pressure can enter skin and cause serious injury.

For jump start, connect negative cable to loader engine last (never at the battery). After jump start, remove negative connection at the engine first.



WARNING

Hot surface and explosion hazards

Dangerous heat and contents under pressure.



WARNING

Entanglement hazard

Avoid all moving parts while the engine is running.





WARNING

Entanglement hazard

Avoid all belts while the engine is running.

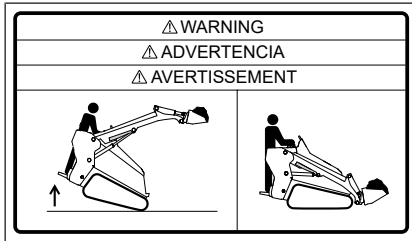

WARNING

Tipping hazard

Carry load low while traveling.



WARNING

Injury hazard

- Do not carry passengers anywhere on the machine.
- Do not use the machine as a person lift.



WARNING

Crushing hazard

- Do not work under a raised lift arm without securing the lift arm support device.
- A disconnected hydraulic line can result in the lift arm dropping.



WARNING

California Proposition 65 Warning

Cancer and Reproductive Harm

www.P65Warnings.ca.gov



Hot surface hazard to the right

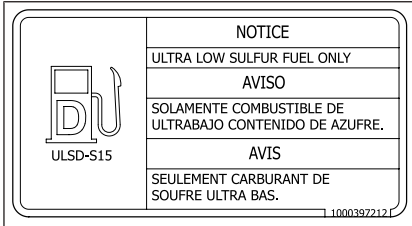

NOTICE

Ultra low sulfur fuel only



4.5 Information Labels

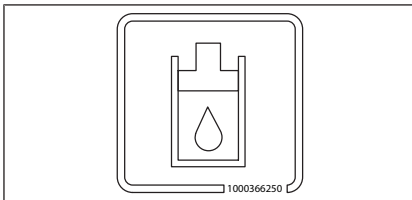

Hydraulic oil fill

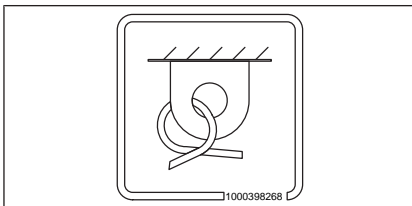

Tie-down point

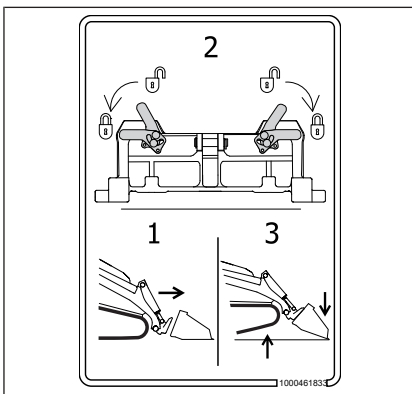

Attachment coupler operation

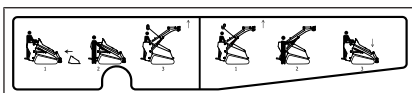

Instructions for using the lift arm support device. For further information, [see Lift Arm Support Device on page 65.](#)

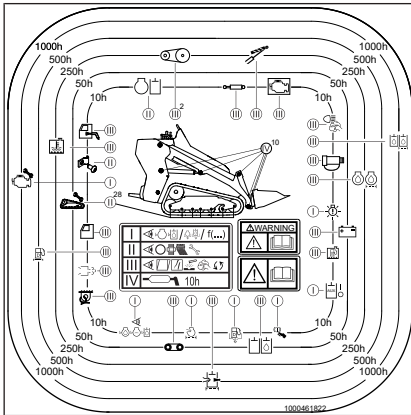

Maintenance schedule

For further information, see [Maintenance on page 67](#).

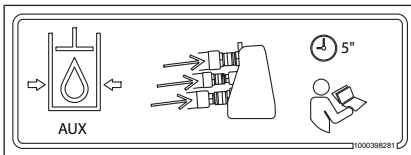

Push in the auxiliary hydraulic connector for 5 seconds to release the pressure in the auxiliary hydraulic circuit.

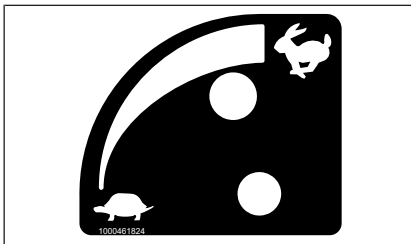

Engine throttle

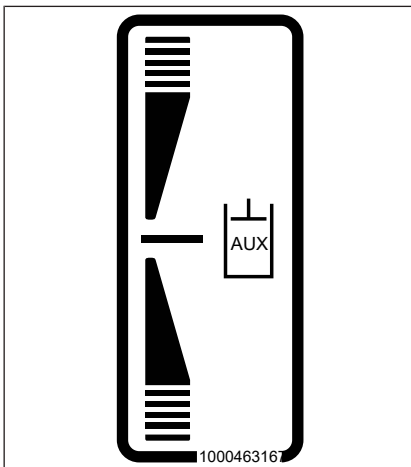

Manual auxiliary control

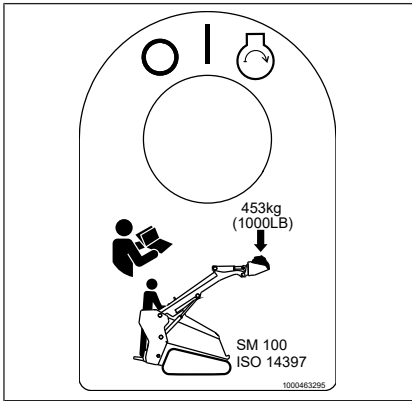

Ignition and rated operating capacity

5 Transportation

5.1 Preparing the Machine for Transportation



⚠ WARNING

Personal injury hazard

Improper loading can result in serious injury or death.

- ▶ Keep others away from the loading area.
- ▶ Drive the machine off the transport vehicle with the help of a guide.

Preparing transport vehicles for loading and unloading

1. Ensure the transport vehicle (trailer, truck) is capable of supporting the machine's weight. For the machine's operating weight, [see Technical Data on page 109](#).
2. Secure the transport vehicle with chocks to prevent it from rolling.
3. If the trailer requires ramps, position the ramps at the smallest possible angle.
4. Use access ramps with an antiskid surface only.
5. Ensure the loading area is clear and that access to it is not obstructed.

5.2 Loading and Unloading the Machine



NOTICE

Machine damage can occur if the machine is not loaded properly.

- ▶ Drive the machine onto the trailer with the heaviest end of the machine going up the ramp first.



NOTICE

Ensure the transport vehicle driver knows the overall height, width, and weight of the transport vehicle (including the machine to be transported) before starting machine travel, and the legal transport regulations of the countries where transport is taking place.

Loading the machine

1. Raise the lift arm so that the attachment (if equipped) does not contact the ramp or the ground.
2. Carefully back the machine onto the middle of the transport vehicle.
3. Lower the lift arm.

4. Stop the engine.
5. Remove the key.

Tying down the machine

- Secure the machine to the transport deck using the specified tie-down points (1) on the machine with certified straps, chains, or cables (2).

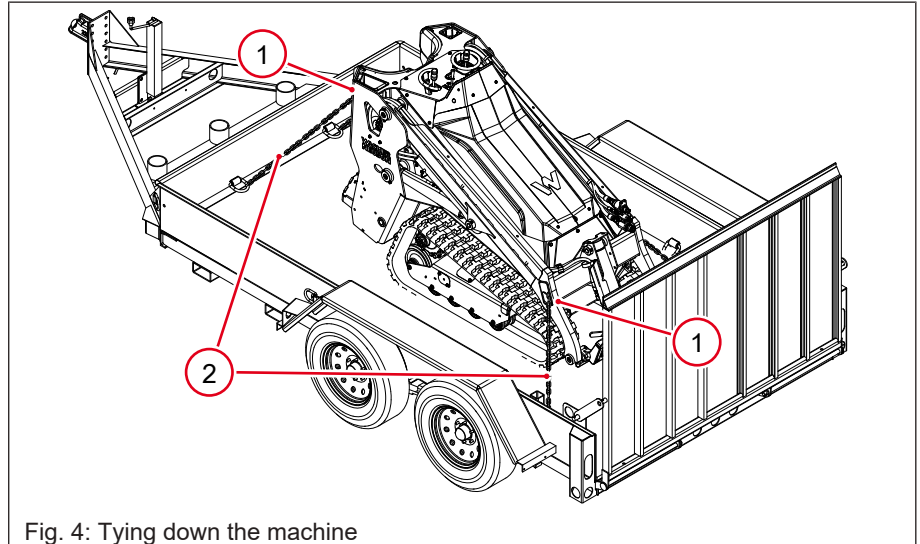

Fig. 4: Tying down the machine

Unloading the machine

1. Ensure the area behind the access ramp is clear and that access to it is not obstructed.
2. Drive slowly down the ramp. Raise the lift arm slightly so that the attachment does not touch the ramp or ground.

5.3 Towing the Machine



NOTICE

Machine damage can occur during towing.

- ▶ The machine may only be towed out of the immediate risk zone. Then, load it on a truck or trailer.
- ▶ Towing the machine can cause excessive, uneven wear.
- ▶ The manufacturer's warranty shall not apply to accidents or damage caused by towing.

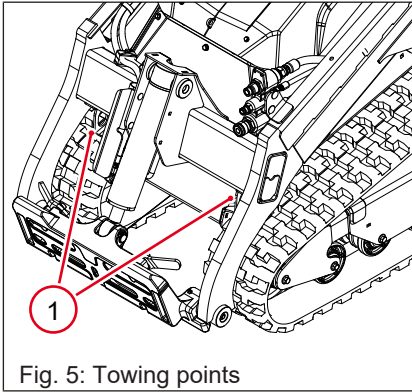

Fig. 5: Towing points

Do not tow this machine, except out of an immediate risk zone or to load onto a transport vehicle. Do not tow another machine with this machine. Only use the points on the frame **(1)** designated for towing.

If towing a short distance is unavoidable, use a towing chain or cable rated at 1.5 times the weight of the machine.

6 Operation

6.1 Risk of Injury or Death

Before putting the machine into operation, ensure no one is at risk of injury or death. The risk zones are the areas in which persons can be seriously injured or killed if struck by, or caught by, the movements of the machine, attachment, load, or moving parts of the machine.

- The risk zone also includes the area that can be affected by falling material, equipment, or by parts that are thrown out.
- The risk zone on a slope is different from the one on a level surface (secure the load). Stop machine operation immediately as soon as someone enters the risk zone. For further information, see [Operating on Slopes on page 56](#).
- Seal off the risk zone if it is not possible to keep a sufficiently safe distance.
- Extend the risk zone sufficiently in the immediate vicinity of buildings, scaffolds, or other elements of construction.

Avoid the following risks:

- Risk of cave-in—do not drive up to the edge of an unsecured pit or trench.
- Risk of collapse—do not undermine the foundations of walls.
- Risk of falling stones, earth, and debris—do not load under projecting earth.
- Risk of tipping over—keep the attachments or work equipment close to the ground.
- Risk of tipping over—keep the load low when moving on slopes—up, down, and across. For further information, see [Operating on Slopes on page 56](#).

Demolition or excavation work

- Do not use the impact force of the attachment to perform demolition work. This can cause serious injury, death, and damage.
- The machine can lose its balance and tip over if heavy attachments (demolition hammers, for example) are used. Proceed as follows when performing such work:
 - Do not lower, turn, or set down the attachment abruptly.
 - Do not extend or retract the lift arm cylinder abruptly. Otherwise, the machine can tip over.

Risk regarding hydraulic system

The machine's hydraulic system is still pressurized even when the engine is not running.

Before starting setup or repair work (for example, installing or removing a hydraulic attachment), release the pressure in the sections of the system and pressure lines that are to be opened.

Avoid risk of injury or death

Before operating the machine, instruct all personnel in the area to stay away from the machine while it is being operated.

While operating the machine, remain aware of people moving in the work area. Be ready to react to these movements if necessary.

Lock the lift arm before servicing the machine. For further information, [see Lift Arm Support Device on page 65](#).

Do not allow someone to approach the machine while the machine is running or with the lift arm raised.

Starting and stopping

- Perform starting and stopping procedures according to this operator's manual.
- Observe all indicator lights.
- Do not use starting fluid (for example, ether). Failure to comply can result in an explosion, which can cause serious injury or death.
- Ensure that the machine is parked on level ground when stopping.
- Set the parking brake to avoid unintentional operation.
- Lower the attachments to the ground before exiting the machine.

After use

- Turn the engine off when the machine is not being operated.
- Ensure that the machine is parked on level ground when not being operated.
- Store the machine properly when it is not being used. The machine should be stored in a clean location out of the reach of children.

6.2 Inspecting the Work Area

Before operating this machine, inspect the work area for unsafe conditions.

Be aware of any sharp drop-offs or rough terrain.

Remove objects or other construction material that could damage the machine or cause personal injury.

Always check for the following ground conditions before operating the machine:

- Inspect for signs of instability such as cracks or settlement.
- Be aware of weather conditions that can affect ground stability.
- Check for adequate traction if working on a slope.

6.3 Break-In Period

New machines require a break-in period to ensure maximum efficiency. During the break-in period, the machine's moving parts stabilize.

This machine has a 6-hour break-in period.

Operating during the break-in period

Follow the recommendations below while operating the machine during the break-in period:

- During the first hour of operation, vary the engine speed and the load on the engine. Short periods of maximum engine speed and load are desirable. Avoid prolonged operation at minimum or maximum engine speeds and loads for the next four to five hours.
- Make sure that the engine oil pressure and engine coolant temperature lights do not illuminate.
- Check the engine oil and coolant levels frequently.
- Warm up the engine and hydraulic system by running the engine at lower speeds and operating the machine at low loads.
- Do not run a cold engine up to high idle or change engine speeds suddenly. For further information, see [Operating the Machine in Extreme Weather Temperatures on page 42](#).
- Avoid sudden machine acceleration, braking, and changing of travel directions.
- Avoid using the machine under heavy loads or at high speeds.
- Follow the machine maintenance schedule.

6.4 Operation Checklists

The checklists below are intended to assist you in checking and monitoring the machine before, during, and after operation. Additional details are found in this manual.

Start-up checklist

The following items should be checked daily before putting the machine into operation:

- Check cooler cores for debris. Clean if necessary.
- Check the fluid levels for fuel, engine oil, hydraulic oil, and engine coolant.
- Keep the machine clean. This reduces the risk of fire hazards, such as combustible material around the engine, and reduces the risk of injury or operational accidents that can be caused by dirt build-up on the operator platform.
- Make sure the attachment is securely locked in place. For further information, Testing the Attachment System.
- Ensure others are clear of the machine before starting the engine.
- Check the control interlock system for proper operation. The ground drive system and the loader control system should not operate without:
 - An operator standing on the platform
 - The operator presence pedal engaged
- Check the parking brake for proper operation.

Operation checklist

The following items should be checked after the engine is started:

- Check that the indicator lights for engine oil pressure and alternator charge functions switch off within a few seconds after the engine is started.
- Check all other indicator lights for any malfunctions.
- Check that the ground drive and loader controls are working properly.

Parking checklist

- Park on a level surface.
- Lower the attachment to the ground. If the lift arm is raised, ensure the lift arm support device is engaged.
- Stop the engine and remove the key if the machine is being left unattended.

6.5 Machine Controls

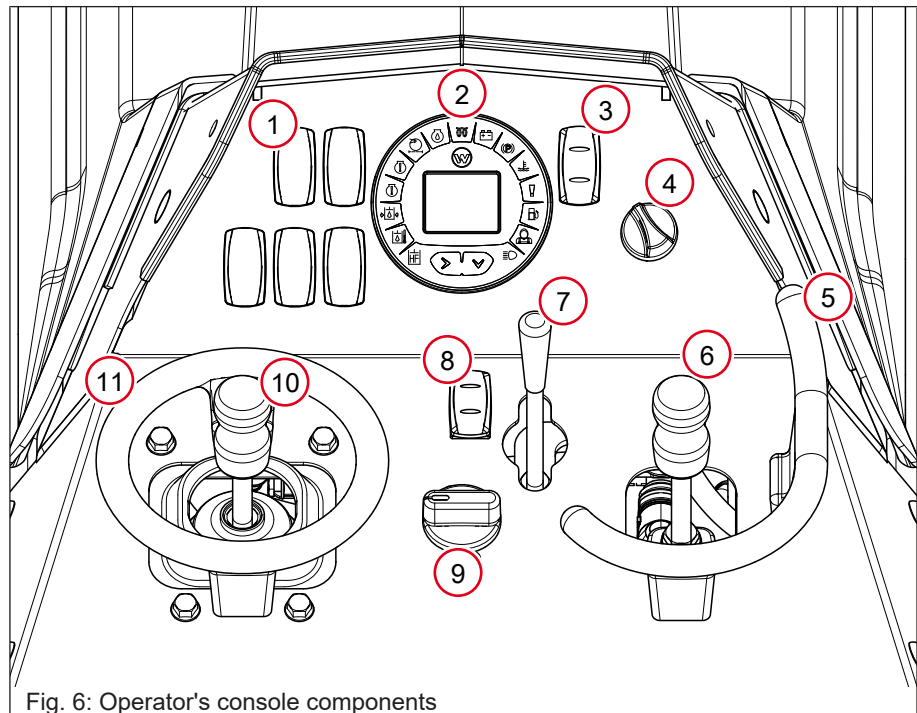

Fig. 6: Operator's console components

Ref	Description	Ref	Description
1	Spaces for optional features	2	Instrument display
3	Parking brake	4	Key switch
5	Right handrail	6	Workgroup joystick control
7	Auxiliary hydraulic control lever	8	Continuous flow switch
9	Hand throttle	10	Ground drive joystick control
11	Left handrail	—	—

6.6 Control Interlock System

The intent of the machine's control interlock system is to ensure the operator is standing on the operator platform and ready to operate the machine before the controls are activated.

If any of these interlocks do not function properly, contact your Wacker Neuson dealer for service. Do not modify the system.

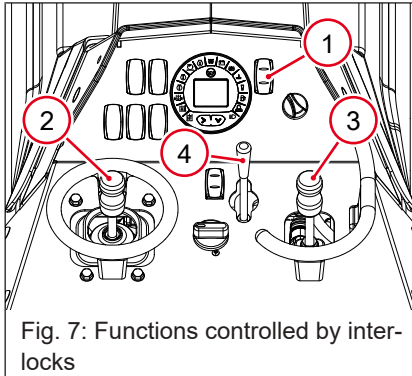

Parking brake switch

The parking brake (indicated by an icon on the display (P) and an illuminated LED on the parking brake switch (1)) defaults to ON when the engine is not running. When the engine starts, press the parking brake switch to release the parking brake.

The parking brake activates when any of the following occur:

- The operator steps off the operator presence pedal.
- The ignition key is turned to Position 0.
- The engine stops.
- The parking brake switch is pressed.

The ground drive, lift arm control, and auxiliary hydraulic functions are not activated until the operator is standing on the platform with the operator presence pedal engaged and the parking brake released.

On the initial start-up of the machine, the operator presence pedal and parking brake switch disengage interlocks. After initial start-up, the operator presence pedal locks all interlocks.

Drive controls

After the initial release of the parking brake switch, to engage the drive control interlock, press the parking brake switch again. The parking brake switch then locks out only the drive system. To disengage the interlock and operate the drive joystick (2), operator must be present while pressing the parking brake switch.

Lift arm controls

During normal machine operation (when the engine is running), the lift arm interlock is dependent on the operator presence pedal. To disengage the interlock, engage the operator presence pedal before operating the loader joystick (3).

If the engine is off, you can lower the lift arm by turning the ignition key to the ON position and holding the park brake switch. For further information, [see Lift Arm Manual Override on page 64](#).

Auxiliary controls

The intent of the auxiliary controls interlock is to prevent unintentional hydraulic flow to attachments. If the operator does not have the operator presence pedal engaged, and the operator shifts the auxiliary control lever out of neutral, the engine will shut down. To disengage the interlock, engage the operator presence pedal before operating the auxiliary control lever (4). For further information on continuous flow operation, [see Auxiliary Override on page 52](#).

6.7 Starting and Stopping the Engine



⚠ WARNING

Personal injury and machine damage hazard

Sudden movement of the engine and/or machine can cause death or serious personal injury. Engaging the starter while the engine is still rotating will result in damage to the starter and flywheel.

- ▶ Check before starting the engine that any tools or shop rags used during maintenance have been removed from the area.



⚠ WARNING

Personal injury hazard

Personal injury can occur if certain conditions are not met. Before starting the engine, the operator must:

- ▶ Remain aware of bystanders.
- ▶ Ensure there is sufficient ventilation before operating the machine in enclosed areas.
- ▶ Start the machine from the operator platform only.
- ▶ Review the starting and stopping procedures in this operator's manual.



NOTICE

Long cranking cycles can damage the starter.

- ▶ Do not crank the starter for more than 15 seconds.
- ▶ Wait 30 seconds before trying to crank the starter again so the battery can recover and the starter does not become overheated.

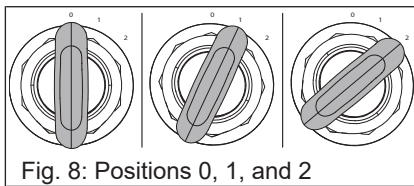

Fig. 8: Positions 0, 1, and 2

Starting the engine

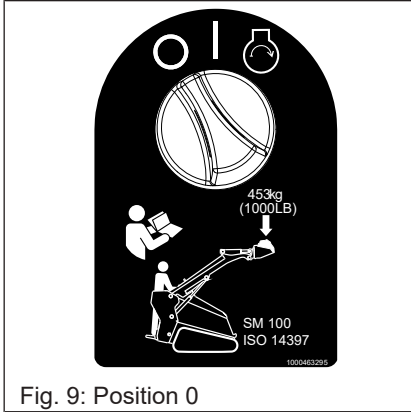

Fig. 9: Position 0

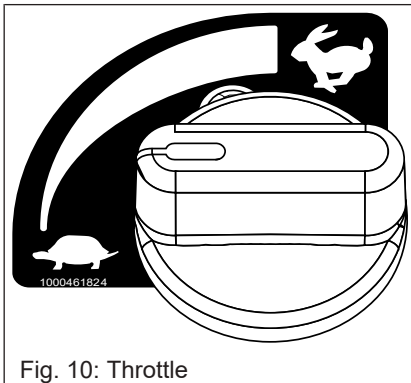

Fig. 10: Throttle

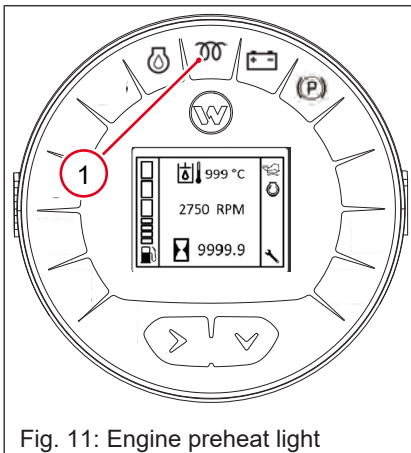

Fig. 11: Engine preheat light

Position	Symbol	Function	
0		Stop position	Insert or remove the key
1		Preheats the engine	Preheater active; all electric functions are enabled
2		Starts the engine	Starter is actuated

- Stand on the operator platform and engage the operator presence pedal.
- Set the throttle to the low idle position.
- Turn the ignition key to position 1.
 - ⇒ The parking brake switch illuminates, and the display turns on. If any indicator fails to illuminate when the key switch is in position 1, contact an authorized Wacker Neuson dealer or service center for assistance before operating the engine.
- Wait until the engine preheat light **(1)** goes off.
- Turn and hold the ignition key to position 2 to crank the engine. When the engine starts, release the ignition key.
 - ⇒ The oil pressure and battery charge status lights turn off. The parking brake light continues to stay illuminated until the parking brake switch is pressed to disengage the brake.

Warm-up phase

- Warm up the engine and hydraulic system by running the engine at half throttle before operating the machine.
- The cold system restriction limits ground speed until a certain temperature is reached. For further information, Cold System Restriction.
- During the warm-up phase, check for unusual noise, exhaust color, leaks, malfunctions, or damage.
- In the case of any malfunctions or damage, do not operate the machine. Contact a Wacker Neuson dealer immediately for assistance.



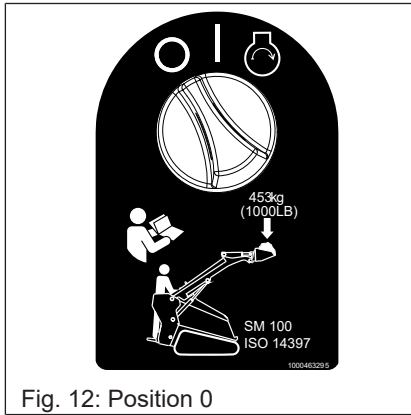

Fig. 12: Position 0

Stopping the engine

1. Unfasten the seat belt in order to avoid unintentional operation.
2. Allow the engine to cool down at low idle for 5 minutes without any load.
3. Turn the key to position 0.
4. Remove the key before leaving the operator platform.

Note: If it is necessary to disconnect the battery after stopping the engine, wait 2 minutes in order to avoid damage to the control electronics.

6.8 Operating the Machine in Extreme Weather Temperatures



⚠ WARNING

Accident hazard

Cold hydraulic oil can lead to unpredictable machine movement and a possible loss of machine control.

- ▶ Operate the machine with extreme care.



⚠ WARNING

Explosion hazard

Evaporative starting fluids can cause unexpected explosions.

- ▶ Do not use evaporative starting fluids, such as ether, on this engine.



NOTICE

Operating the machine without warming it up first can render the machine ineffective and equipment damage can occur.

- ▶ Warm up the machine according to the information below.

Do not use the machine in ambient temperatures above 45°C (113°F) or below -20°C (-4°F).

Carefully observe the recommendations in the following sections when operating the machine in extreme temperatures.

Cold temperatures

Cold temperatures affect the engine's starting capability, and the hydraulic systems will be sluggish until the system temperatures increase to the normal operating range. The following are actions that help minimize cold start effects.

Engine/electrical

- Use proper diesel fuel for the ambient temperature.
- Use engine oil with the proper viscosity. For further information, [see Engine Oil Viscosity on page 74](#).
- Check the engine coolant mixture for proper antifreeze mix.
- Make sure the battery is fully charged.
- Check to see if the battery connections and the connections to the starter and engine block are clean.
- Start the engine. For further information, [see Starting and Stopping the Engine on page 40](#).

Hydraulic system

- Use proper hydraulic oil.
- Prevent damage to the hydraulic system by operating the machine at low loads. Follow the warm-up procedures before using the machine at full load.

Hot temperatures

Hot temperatures affect the engine and the hydraulic cooling systems.

The following are actions that help minimize issues with overheating of the machine.

Engine/cooling

- Check the engine coolant mixture for proper antifreeze mix.
- Check the engine coolant level.
- Check the radiator cap for damage. Replace the cap if it is damaged.
- Keep the radiator core clean by removing dirt and debris.
- Use engine oil with the proper viscosity.

Hydraulic system

- Use proper hydraulic oil.
- Keep the oil cooler core clean by removing dirt and debris.
- Operate the machine at a lower load.
- When operating an attachment, avoid the following; otherwise, the hydraulic system will run over a relief valve, resulting in excessive heat build-up in the hydraulic oil:
 - Holding the right hand lever or joystick in place when the attachment has been fully extended or retracted
 - Holding the auxiliary lever in place when an attachment stops moving
- Avoid driving for excessive amounts of time.

6.9 Instrument Display

The instrument display informs the operator of the operating states, required maintenance, or possible machine malfunctions.

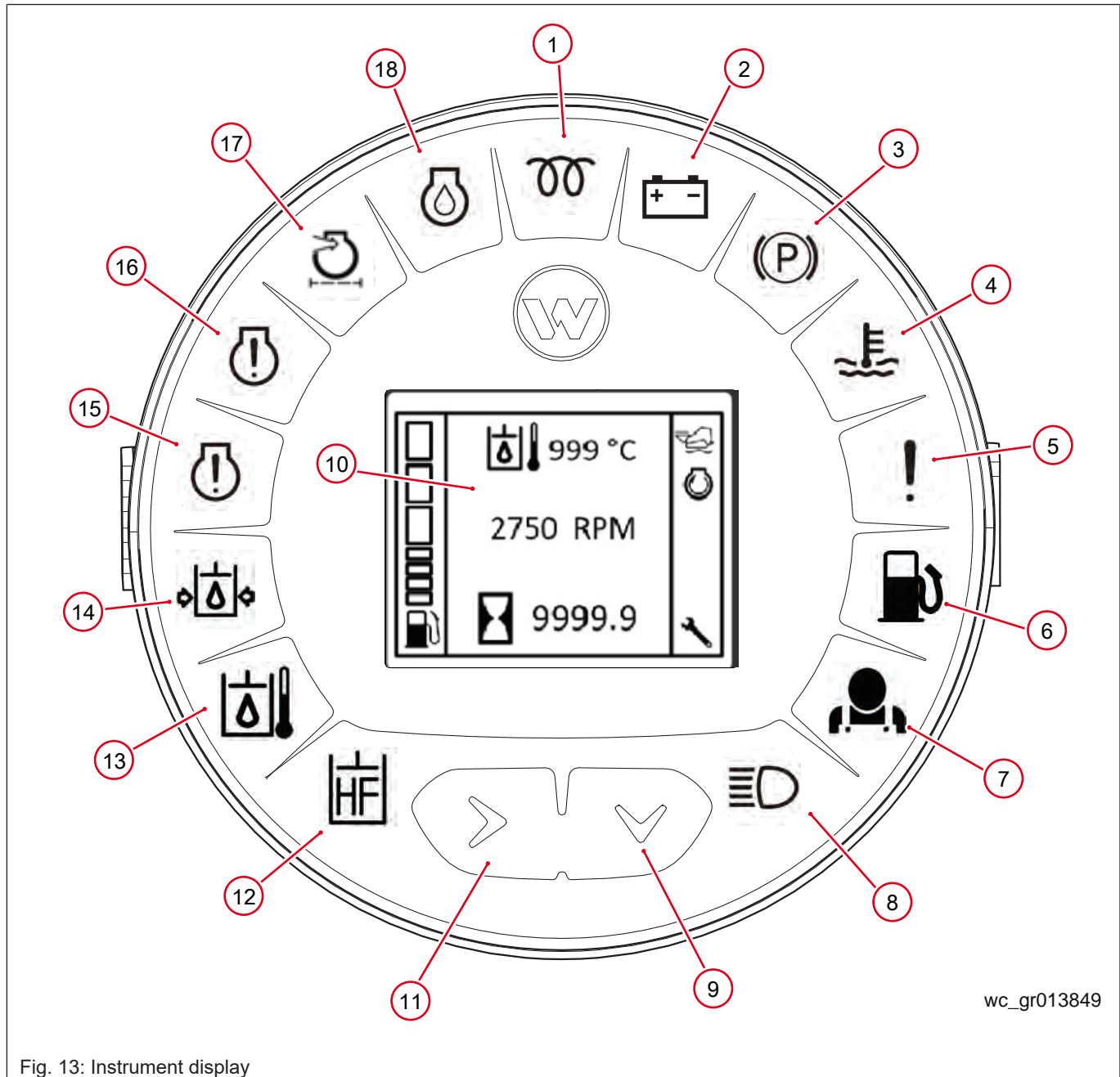









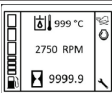









Fig. 13: Instrument display









Instrument display indicator lights







Ref	Symbol	Color	Function
1		Yellow	Engine preheating
2		Red	Battery charge indicator light
3		Red	Parking brake
4		Red	Engine coolant temperature
5		Red	General malfunction
6		Yellow	Low fuel
7		Red	Operator presence
8		Blue	Work lights
9		—	Selector button (instrument display)
10		—	Instrument display (for further information, see the next section.)
11		—	To next menu page/set (instrument display)
12		Green	High flow (not used on this model)
13		Red	Hydraulic oil temperature
14		Red	Hydraulic oil pressure
15		Red	Engine stop
16		Yellow	Engine warning

6.10 Instrument Display Symbols and Functions

Ref	Symbol	Color	Function
17		Red	Air filter restriction
18		Red	Engine oil pressure

6.10 Instrument Display Symbols and Functions

Symbol	Function
	Auto idle
	Service wrench
	Cold system restriction warning
	Hydraulic oil filter clogged
	Auxiliary continuous flow active
	Hydraulic oil temperature
	Engine speed
	Elapsed operating hours meter
	Fuel level

Symbol	Function
	Unable to disengage parking brake—auxiliary
	Unable to disengage parking brake—operator not present
	Unable to disengage parking brake—engine off
	Unable to disengage parking brake—hydraulic oil temperature too low
	Operating hours to next maintenance
	Operator unsafe shutdown warning

6.11 Instrument Display Subpages Menus

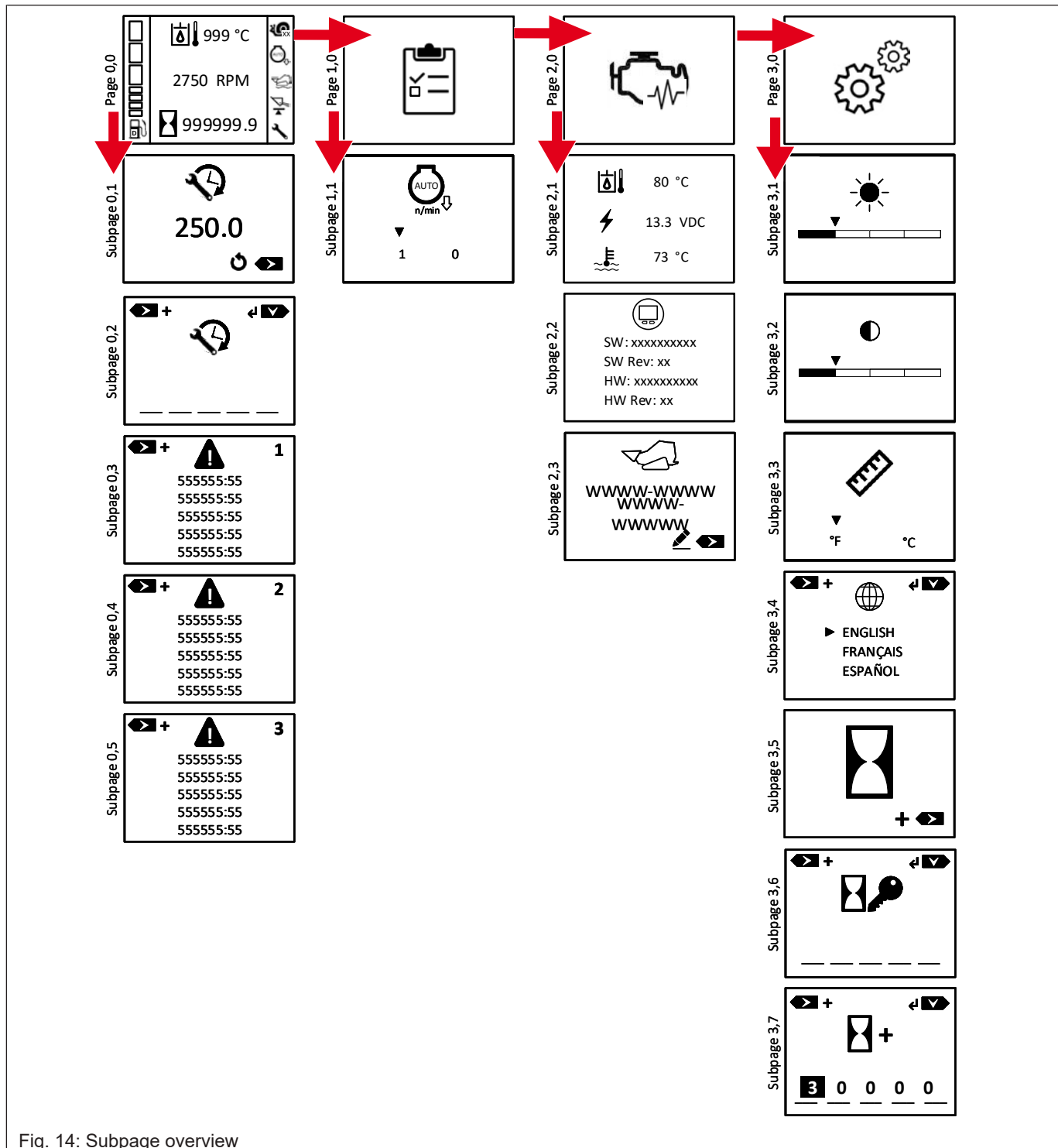

Fig. 14: Subpage overview

6.12 Machine Status Screens

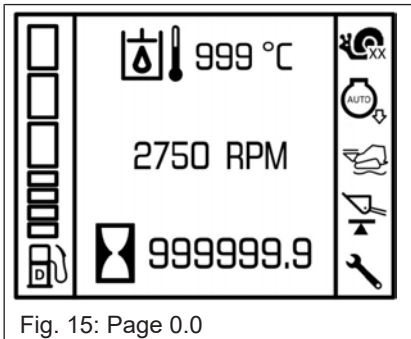

Fig. 15: Page 0.0

Page 0.0—Main display screen

For descriptions of each of the icons displayed on this screen, see [Instrument Display Symbols and Functions on page 46](#).

The following machine statuses are accessible through this screen:

- Service meter
- Diagnostic trouble codes

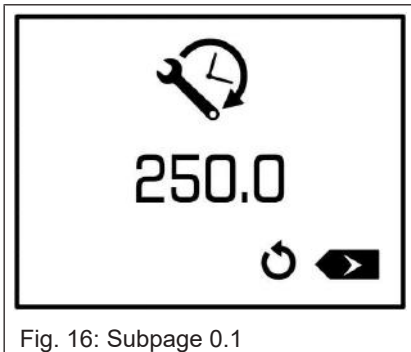

Fig. 16: Subpage 0.1

Subpage 0.1—Service meter

This page displays the remaining hours until service is due. The service interval is a set 250 hours. After the meter reaches 0, a negative number displays until the meter is reset.

To reset the service meter, press the next menu/set button (right arrow) (2) to access Subpage 0.2—Service meter reset.

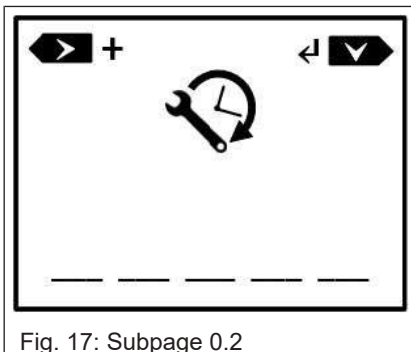

Fig. 17: Subpage 0.2

Subpage 0.2—Service meter reset

Enter the passcode on this page to reset the maintenance hours. Press the next menu/set button (right arrow) (2) to change the number. Press the selector button (down arrow) (1) to move to the next number.

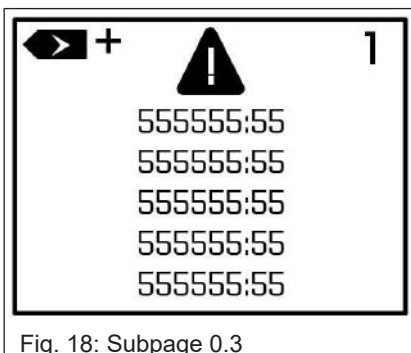

Fig. 18: Subpage 0.3

Subpages 0.3 through 0.5—Diagnostic trouble codes

Engine control unit and display error codes are shown on these screens. For further information, see [Diagnostic Trouble Codes on page 103](#).

6.13 Machine Options

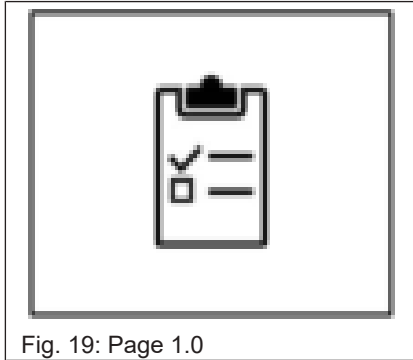

Fig. 19: Page 1.0

Page 1.0—Machine Options

Auto-idle is accessible through the Machine Options screen.

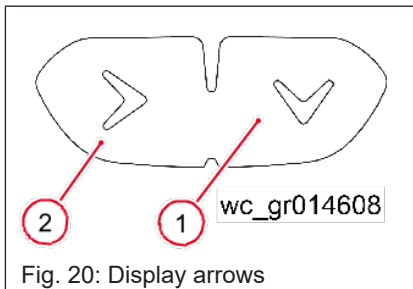

Fig. 20: Display arrows

Subpage 1.1—Auto-Idle

Auto-idle returns the engine RPMs to low idle after a set of criteria have been satisfied. When criteria are no longer met, the engine RPMs return to the throttle commanded value. These criteria are as follows:

- Engine coolant temperature above 25°C (77°F)
- Hydraulic oil temperature above 25°C (77°F)
- Not connected to WANDA
- Auto-idle delay time exceeded
- Throttle is moved more than 5%
- Operator is off the operator's platform

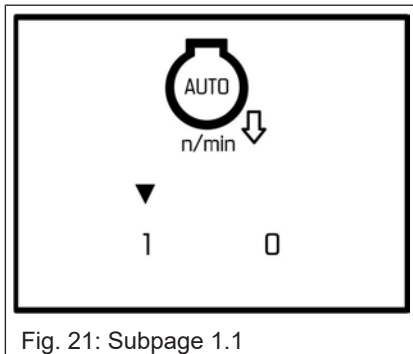

Fig. 21: Subpage 1.1

The Auto-idle ON-OFF status is saved to memory, and is resumed after turning the engine off and back on.

Use the selector button (1) and the next menu button (2) at the bottom of the instrument display to scroll through the screens to get the screen shown to turn the auto-idle on or off.

6.14 Machine Vitals

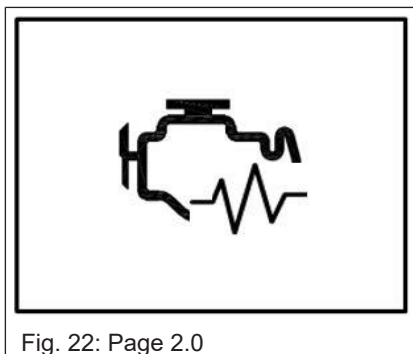
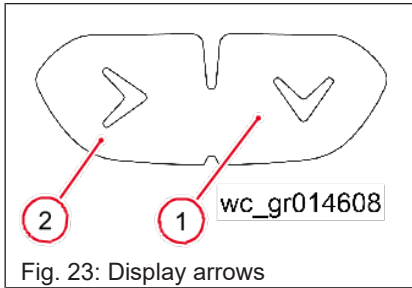

Fig. 22: Page 2.0

Page 2.0—Machine Vitals

The following machine vitals are accessible through this screen:

- Machine sensors
- Display data
- Machine serial number



Subpages 2.1 through 2.3—Machine Vitals

Use the selector button (1) and the next menu button (2) at the bottom of the instrument display to scroll through the screens to get the screen shown to view the hydraulic oil temperature, system voltage, and engine coolant temperature; view the software and hardware material number and version; and view and reset the serial number.

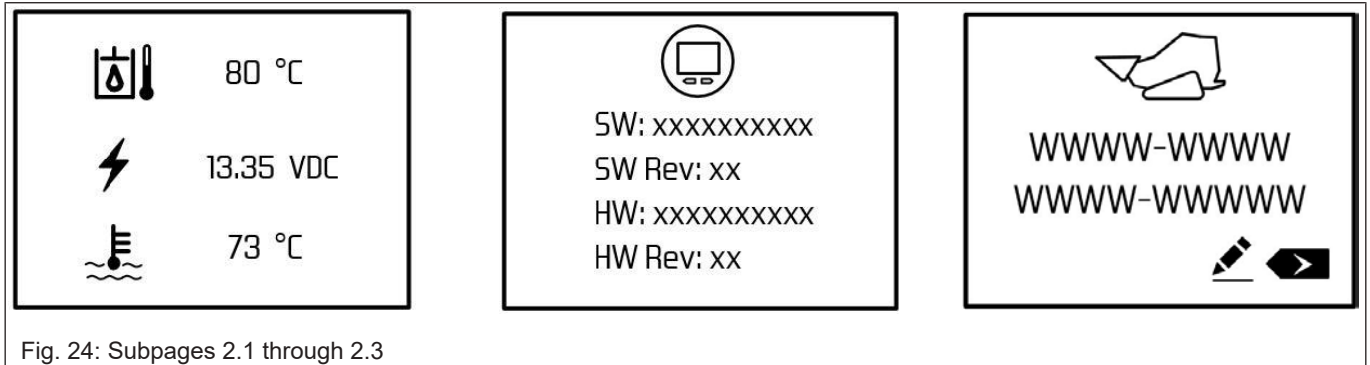

6.15 Instrument Display Settings

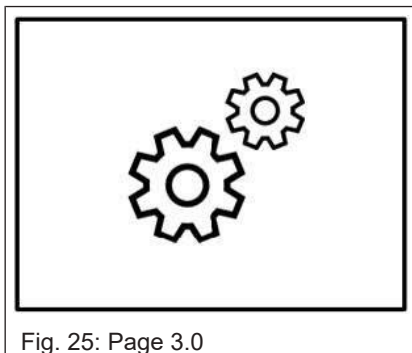

Page 3.0—Display Settings

The following display settings are accessible through this screen:

- Brightness
- Contrast
- Display units, °F or °C
- Language
- Machine hours

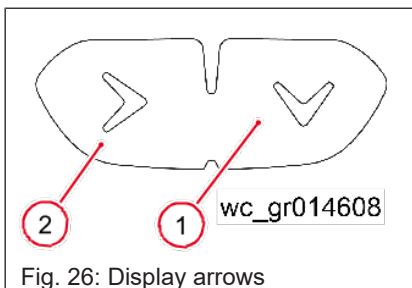

Use the selector button (1) and the next menu button (2) at the bottom of the instrument display to scroll through the screens to get the screen shown to adjust the brightness, adjust the contrast, change between Fahrenheit and Celsius, change the language, or increment the machine hours.

6.16 Auxiliary Override

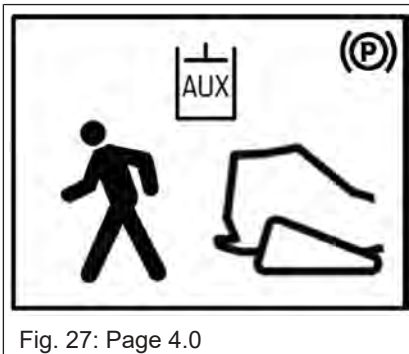

Fig. 27: Page 4.0

Page 4.0—Auxiliary Override

This page appears when auxiliary override mode is activated. Use auxiliary override mode to operate auxiliary functions while standing off the operator platform.

To engage auxiliary override mode, the following criteria must be met:

- Operator present
- Engine running
- Auxiliary control out of NEUTRAL
- Continuous flow switch pressed for at least 3 seconds
- After the initial release of the parking brake, you can activate auxiliary override mode when the parking brake is set.

While in auxiliary override mode, the parking brake is engaged, and the hydraulic oil flow for an attachment is continuous.

To deactivate auxiliary override:

- Press the parking brake switch.
- Press the continuous flow switch.
- Move the auxiliary control lever to NEUTRAL.
- Turn off the engine.

The main display screen appears.

6.17 Adjusting the Operator Platform

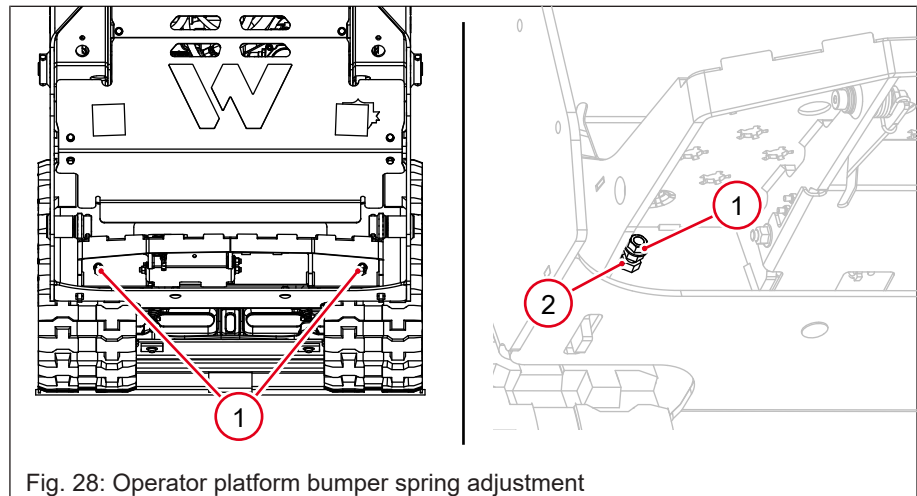

Fig. 28: Operator platform bumper spring adjustment

Tightening the operator platform

1. Locate the flange nut (1) around the bumper spring under the operator platform.
2. Loosen the nut (2) against the operator platform weldment.
3. Tighten the flange nut to push the bumper spring against the chassis weldment.

4. When you have finished the adjustments, tighten the nut against the operator platform weldment to hold the bumper spring in place.
5. Repeat on the other side.

Loosening the operator platform

1. Loosen the nut **(2)** against the operator platform weldment.
2. Loosen the flange nut **(1)** to pull the bumper spring away from the chassis weldment.
3. When you have finished the adjustments, tighten the nut against the operator platform weldment to hold the bumper spring in place.
4. Repeat on the other side.

6.18 Ground Drive and Loader Controls

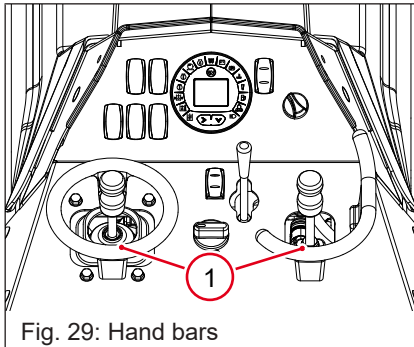

Fig. 29: Hand bars

To have good control of the machine, move the levers smoothly, using the handrail **(1)** while operating.

For maximum power to the tracks, move the controls most of the way off neutral.

For maximum ground speed, move the controls to full stroke position.

All ground drive and loader controls are spring centered to neutral. This means when you let go of the controls, they will return to neutral.

Hydraulic pilot ISO controls

The left joystick controls all of the ground drive functions (tracks), and the right joystick controls all of the loader functions (lift arm and attachment tilt).

Note: Use the handrail when operating the controls.

- Move the right joystick back to raise the lift arm.

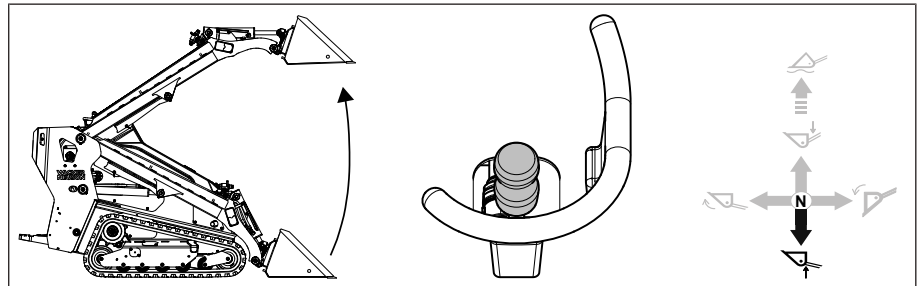

- Move the right joystick forward to lower the lift arm.

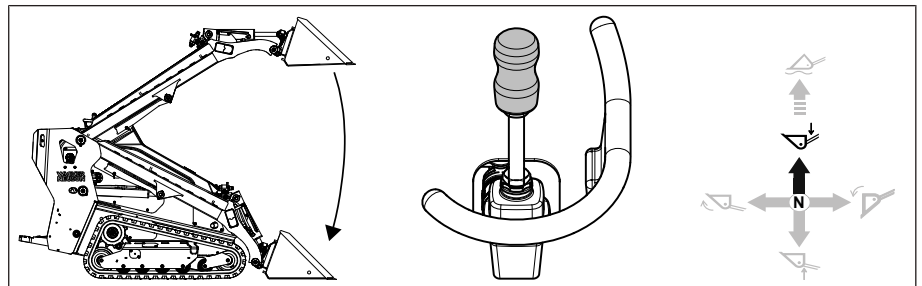

- Move the right joystick to the left to roll the attachment inward.

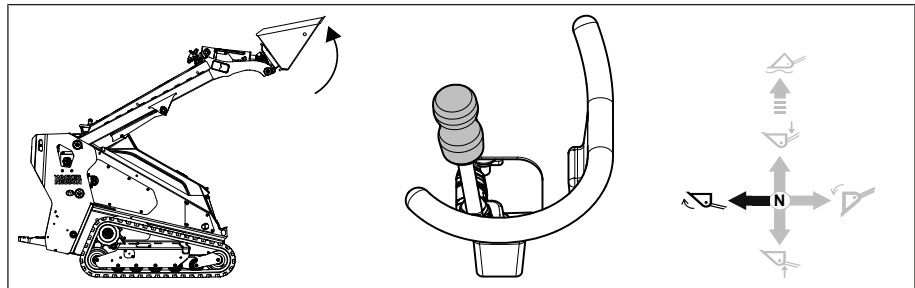

- Move the right joystick to the right to roll the attachment outward.

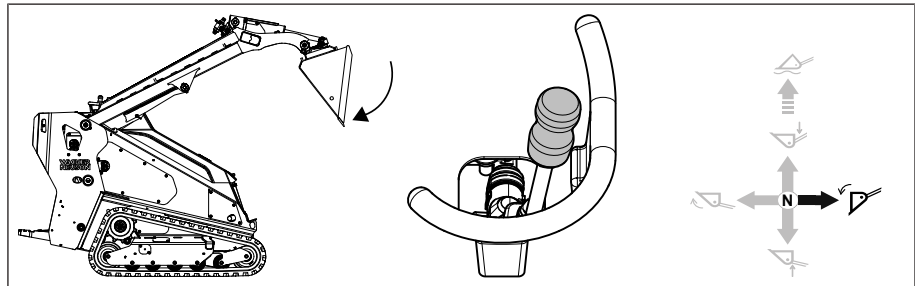

Ground drive control joystick functions

The left joystick controls all of the ground drive functions.

Note: Use the handrail when operating the controls.

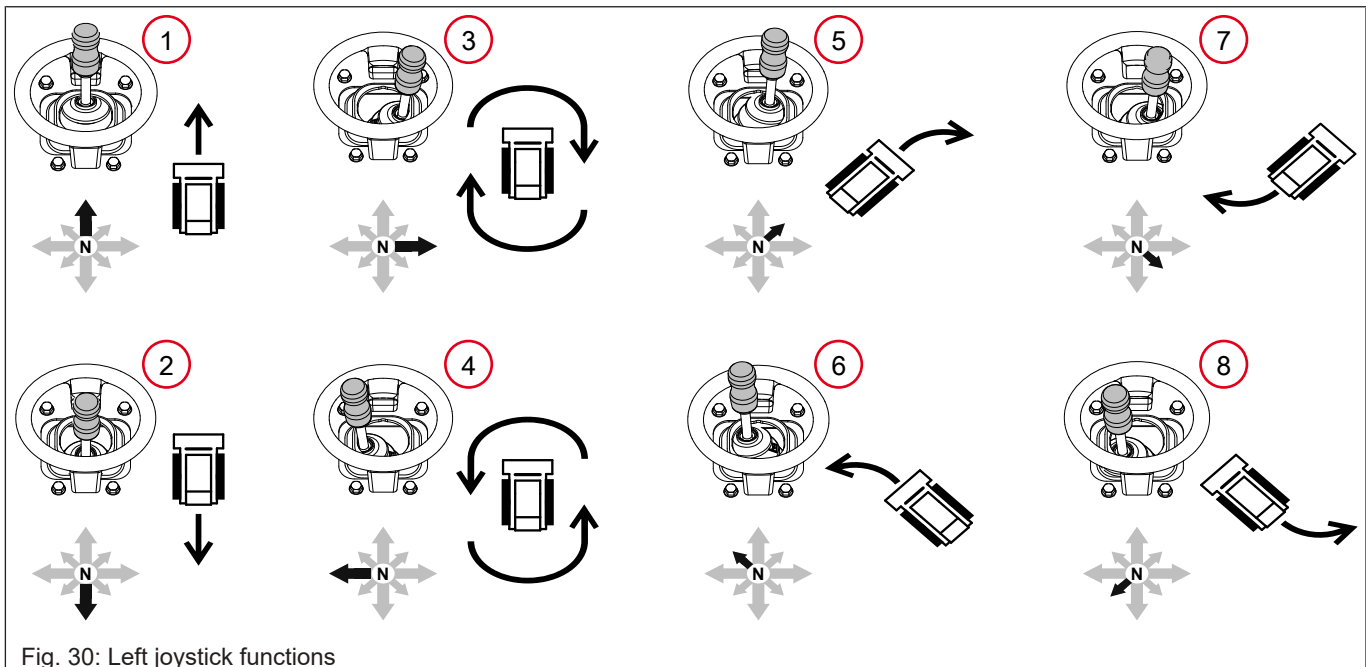

Fig. 30: Left joystick functions

Refer to the illustration for the necessary joystick motions to move the machine as desired. Use the left joystick to move and turn the machine.

- | | |
|----------------|----------------------|
| 1—Forward | 5—Forward right turn |
| 2—Reverse | 6—Forward left turn |
| 3—Rotate right | 7—Reverse right turn |
| 4—Rotate left | 8—Reverse left turn |
| | N = Neutral |

6.18.1 Float Position



⚠ WARNING

Crushing hazard

When float is activated with the lift arm in the raised position, the lift arm will lower to the ground.

- ▶ Keep others clear of the area.

The float position for the lift arm is usually used to level loose material by allowing the bucket, or attachment, to follow the contour of the ground.

Engage the float function by pressing the right joystick forward into a de-tented position (beyond the maximum lift arm down position) The tilt function can be used while the float function is active. To disengage float, move the lift arm control to raise the lift arm.

6.18.2 Leveling the Ground Using the Float Function

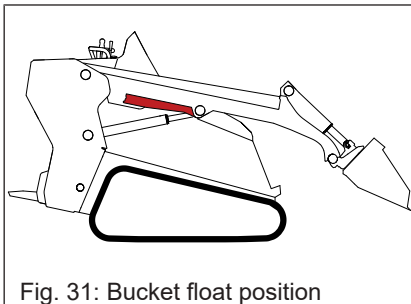

Fig. 31: Bucket float position

1. Raise the lift arm.
2. Tilt the bucket to a horizontal position or beyond.
3. Move the lift arm control past the lowering position into the float position to activate the float function.
4. Adjust the bucket angle.
5. Look to the rear before operating the machine in reverse.
6. To disengage float, move the lift arm control to raise the lift arm.

6.18.3 Using the Brakes

Overview

This machine uses a hydrostatic transmission. Track movement is controlled by the movement of the left joystick.

The joystick is spring-loaded back to the neutral position. If you remove your hand from the joystick, the machine will stop.

6.19 Operating on Slopes



⚠ WARNING

Crushing hazard

Do not operate the machine sideways on slopes. The machine can tip or roll over, even on stable ground.

- ▶ Operate the machine straight up and down slopes with the heavy end of the machine uphill.
- ▶ Do not turn with the machine on a slope.
- ▶ Keep the lift arm low to the ground.
- ▶ Maintain control of the machine by adjusting the travel and movements speeds for the operating conditions.

Overview

When operating on slopes or hills, special care must be taken to reduce the risk of personal injury or damage to the machine. The maximum operating angle rating is 17.5°.

The risk zone on a slope is different from the one on a level surface. Stop machine operation immediately as soon as someone enters the risk zone. For further information, [see Safety Guidelines for Operating the Machine on page 14](#).

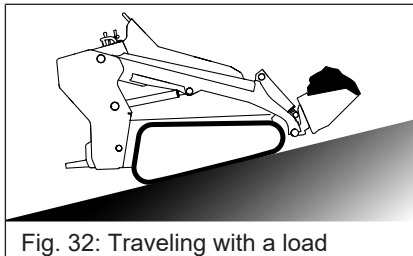

Fig. 32: Traveling with a load

Traveling with a load

- When loaded, point the load uphill on slopes.
- To avoid tipping, carry loads close to the ground, yet high enough to clear obstacles.
- Drive up and down slopes slowly.
- Do not drive diagonally across slopes.
- Do not make sharp turns on slopes, or the machine may roll over.

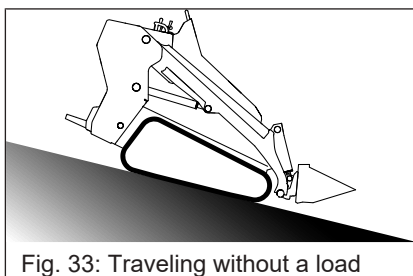

Fig. 33: Traveling without a load

Traveling without a load

- When unloaded, point the back of the machine uphill on slopes.
- Keep the lift arm low to the ground, yet high enough to clear obstacles.
- Drive up and down slopes slowly.
- Do not drive diagonally across slopes.
- Do not make sharp turns on slopes, or the machine may roll over.

Surface conditions

- Pay attention to changing surface conditions while operating the machine. Adjust speed and travel direction as necessary to maintain safe operation.
- Machine stability and traction can be severely reduced when operating on uneven or rough terrain, rocky soils, or wet or loosely packed surface materials.

- The machine can suddenly tip, sink, or fall when moved onto surfaces that have newly filled earth.
- Drive slowly when operating on rough terrain.

Operating over curbs

- The machine tips quickly forward or backward as it travels over a curb. Keep feet and body inside the operator's station and away from the tracks at all times.
- Do not drive the machine in reverse over a curb with no load or the lift arm raised.
- If repeatedly driving over a curb is necessary, build a dirt ramp to make the ascent more gradual.

6.20 Using the Manual Coupler

A coupler is a device for mounting and removing attachments without the aid of tools.



⚠ WARNING

Crushing hazard

- ▶ Keep others clear of the area while mounting or removing attachments.
- ▶ Keep hands clear of the area while mounting or removing attachments.
- ▶ After the attachment has been mounted, check the coupler lower pin engagement to make sure the attachment is secured. This will prevent the attachment from falling off during machine operation.
- ▶ Set the attachment on level ground when removing it to ensure stability.

Notes

- Use only attachments that are approved by Wacker Neuson.
- Read and understand the instructions for use and operation of any attachment used on this machine.
- Make sure the mounting pad on the attachment is clear of any debris to allow to proper mounting of the attachment.

Mounting an attachment

1. Set the lock levers **(1)** to the unlocked (up) position.
Note: The attachment should be in a stable position on level ground.
2. Stand on the operator platform and engage the operator presence pedal.
3. Start the engine and disengage the parking brake.
4. Tilt the coupler forward.
5. Ensure the lift arm is completely lowered.

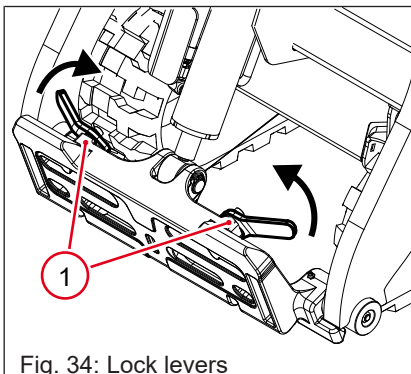
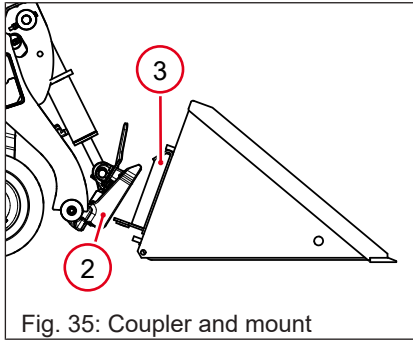
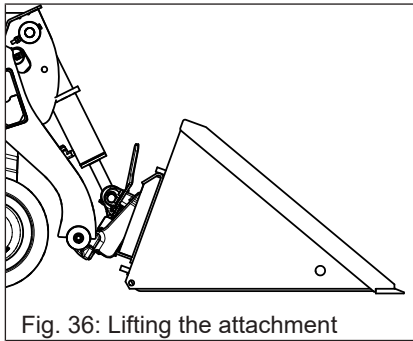

Fig. 34: Lock levers



6. Move the machine forward until the coupler (2) is under the attachment's upper mount (3).



7. Raise the lift arm until the coupler begins to lift the attachment.

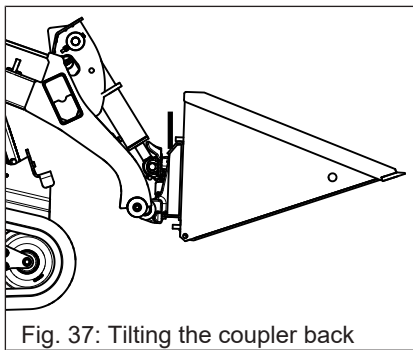

8. Tilt the coupler back until the attachment mount is against the coupler frame.
9. Lower the lift arm completely with the attachment slightly rolled back.
10. Stop the engine.

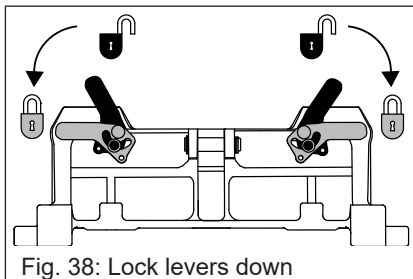

11. Set the lock levers down to the locked position.
12. Check the coupler to ensure the attachment is secure.

Testing the Attachment System

For buckets, lower the lift arm fully and tilt the bucket down until the front of the machine lifts off of the ground.

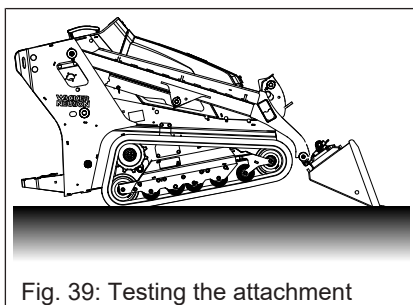

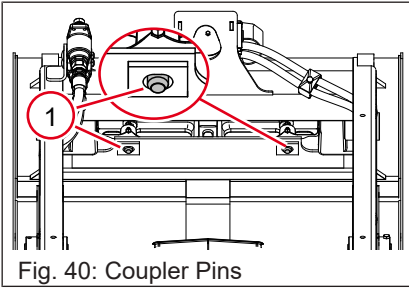

With any attachment, ensure the lower coupler pins **(1)** protrude through the attachment's lower mounting plate.

Removing an attachment

1. Lower the lift arm completely. Then, tilt the attachment back slightly so that it is not touching the ground.
2. Stop the engine.
3. Set the lock levers **(1)** in the unlocked (up) position.
4. Start the engine and press the parking brake switch to disengage the parking brake.
5. Tilt the coupler forward until the upper guide **(2)** clears the attachment's upper mount **(3)**.
6. Move the machine in reverse away from the attachment.

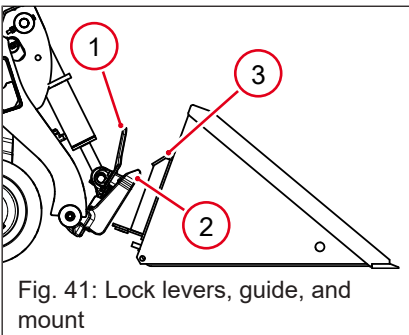

Note: Tilting the attachment back reduces the force to set the lock levers in the locked and unlocked positions.

6.21 Auxiliary Hydraulic Connections



⚠ WARNING

Severe injury hazard

Hydraulic oil, tubes, and hoses are under high pressure and become very hot during operation.

- ▶ Relieve the hydraulic system pressure before connecting or disconnecting any hydraulic components.
- ▶ Do not disconnect hydraulic system lines until components have cooled.

Overview

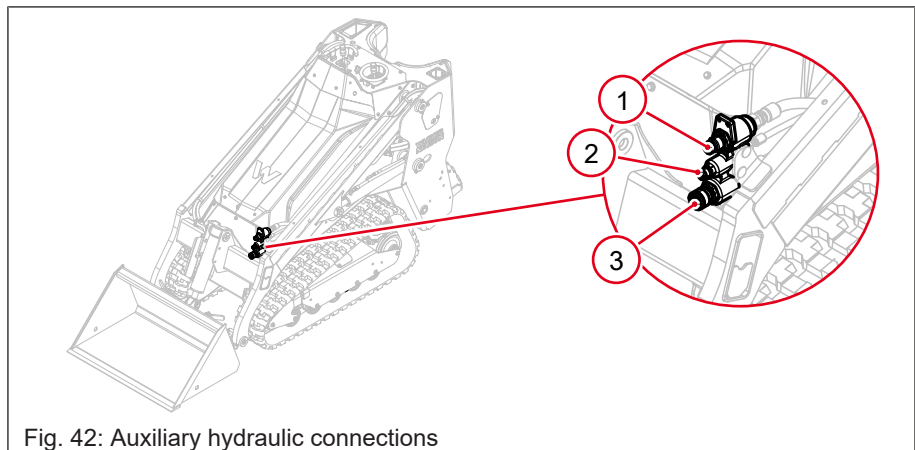

Fig. 42: Auxiliary hydraulic connections

Ref	Function
1	Male auxiliary hydraulic connector (supply)
2	Case drain line
3	Female auxiliary hydraulic connector (return)

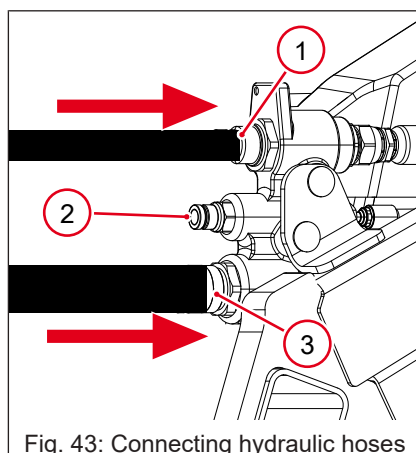
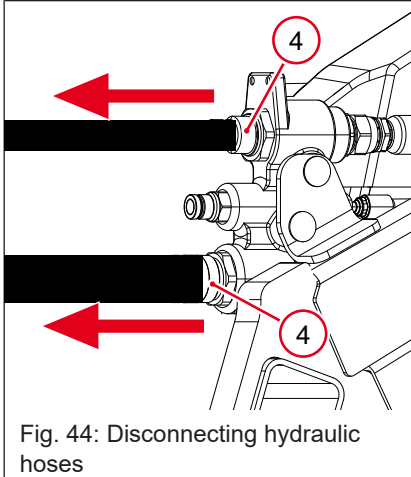

Fig. 43: Connecting hydraulic hoses

Connecting hydraulic hoses

1. Lower the lift arm.
2. Stop the engine.
3. Clean the couplers with a clean cloth.
4. Push in the top and bottom couplers (deluxe only) or move the auxiliary hydraulic control lever back and forth to relieve pressure in that auxiliary hydraulic hose circuit.
5. Push the male connector attachment to the female auxiliary hydraulic connector (bottom) (1).
6. Push the female connector attachment to the male auxiliary hydraulic connector (top) (2).
7. Push the case drain connector attachment (if present) onto the case drain line (middle) (3) connector (deluxe only).



Disconnecting hydraulic hoses

1. Lower the lift arm.
2. Stop the engine.
3. Push in the top and bottom couplers (deluxe only) or move the auxiliary hydraulic control lever back and forth to relieve pressure in that auxiliary hydraulic hose circuit.
4. Pull the rings (4) on the female couplers to release the hoses from the machine.

6.22 Manual Auxiliary Controls

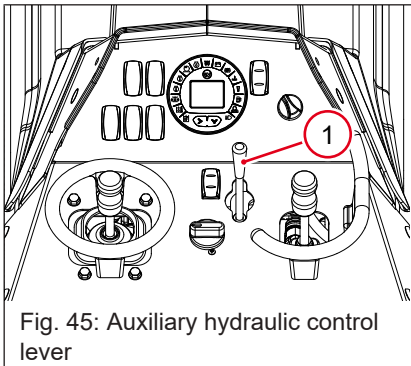

Push the auxiliary hydraulic control lever (1) forward for auxiliary hydraulic oil flow to the front male coupler. Hydraulic oil flow increases to the coupler as the lever is pushed forward.

Pull the auxiliary hydraulic control lever backward for auxiliary hydraulic oil flow to the front female coupler. Hydraulic oil flow increases to the coupler as the lever is pulled backward.

6.23 Filling and Dumping the Bucket



▲ WARNING

Accident hazard

Operate the machine with extreme care to avoid possible loss of machine control.

- ▶ Know the machine's lifting capacity. Do not exceed the ROC for the machine. For further information, [see Forces on page 112](#).
- ▶ Dump the load with the machine on a level surface.

Filling the bucket

1. Lower the lift arm.
2. Tilt the bucket so it is flat on the ground.
3. While driving the machine slowly forward into the pile, tilt the bucket back and raise the lift arm at the same time to fill the bucket.
4. Reverse away from the pile, turn the machine around on level ground, then travel to the dumping location with the bucket low to the ground.

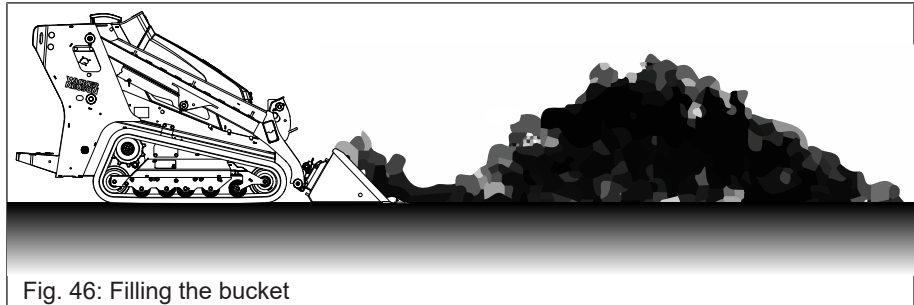

Dumping the bucket

1. Raise the lift arm while keeping the top edge of the bucket level to prevent spilling the load.
2. Dump the load.

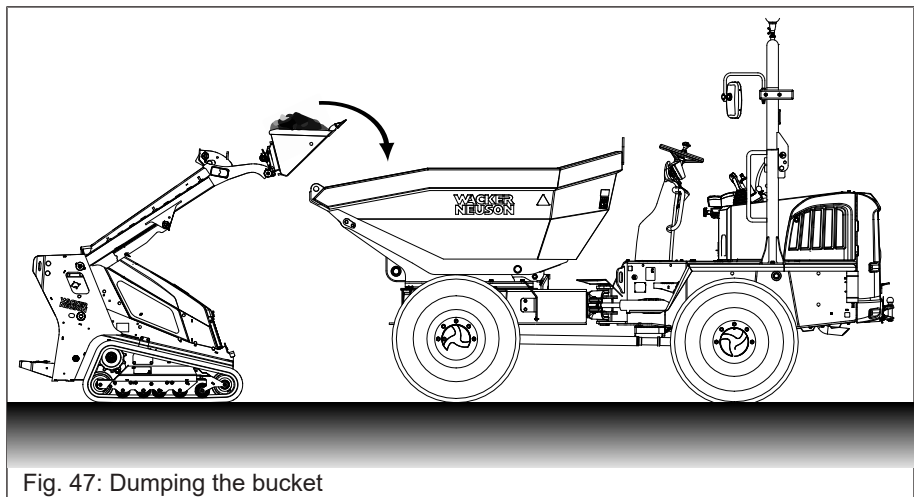

6.24 Recommended Fuels—Diesel and Biodiesel



⚠ WARNING

Fire hazard

Do not use gasoline, kerosene, kerosene mixes, crankcase oil, or any oil containing gasoline as fuel for this machine.



NOTICE

Poor quality fuel can reduce engine performance and cause damage. Only use the recommended diesel fuels for the best engine performance. The recommended fuel complies with the U.S. EPA and ARB protection guidelines.

Use the same diesel fuel that is used in cars.

Fuel requirements

- Fuel must meet the ASTM D975, EN590:96, ISO 8217 DMX, BS 2869-A1 or A2, JIS K2204 Grade No. 2, KSM-2610, or GB252 standard.
- Biodiesel fuel for blending must meet the EN14214 or ASTM D-6751 and D7467, or JIS K2390 standard. (Blend ratios up to B20 are acceptable.)
- Fuel sulfur content must not exceed 0.5% by volume. Less than 0.05% is preferred. In the U.S. and Canada, it is illegal to use greater than 0.0015% sulfur.
- Do not use kerosene or mix kerosene with fuel.
- Do not use fuel stored for an extended time.

Diesel fuel

Low temperatures cause diesel fuel to gel. Use the proper fuel for the conditions. Follow the guidelines in the table below.

Lowest Expected Temperature °C (°F)	Recommended Fuel
Above 0 (32)	#2 diesel plus additives (ULSD only ¹⁾)
Above -20.5 (-5)	#1 diesel plus additives (ULSD only ¹⁾)

1) In the U.S. and Canada, use only ULSF. Otherwise, high sulfur fuel less than 5,000 ppm is acceptable. However, a sulfur fuel with lower PPMs is recommended.

Biodiesel fuel

Use the following recommended biodiesel fuels.

Biodiesel Fuel	Maximum % in Fuel
EN14214	20%
ASTM D 6751-09a	—

6.25 Refueling the Machine



⚠ WARNING

Fire and explosion hazard

Fuel and its vapors are extremely flammable and can be explosive. Burning fuel can cause severe burns.

- ▶ Keep all sources of ignition away from the machine while refueling.
- ▶ Store fuel containers in a well-ventilated area, away from any combustible materials or sources of ignition.
- ▶ Refuel only when the machine is outdoors.
- ▶ Clean up spilled fuel immediately.
- ▶ Do not smoke while refueling.
- ▶ To prevent static electricity buildup when transferring the fuel from the pump to the container, place the fuel container on the ground. Hold the hose nozzle firmly against the side of the container while filling it.



CAUTION

Fire and health hazard

Fuel expands when heated. Expanding fuel in an over-filled tank can lead to spills and leaks.

- ▶ Do not fill the fuel tank completely.



NOTICE

Keep the fuel tank and fuel-handling equipment clean at all times. Be careful not to let any contaminants or even dust from the outside into the filler port when supplying fuel.

Do not remove the primary strainer (if equipped) from the fuel tank filler port. If removed, dirt and debris could get into the fuel system causing it to clog.

Requirements

- Machine and fuel tank supply level with the ground
- Fresh, clean fuel supply

Procedure

1. Stop the engine.
2. Remove the fuel cap (1).
3. Fill the fuel tank.
4. Install the fuel cap.
Note: Replace the fuel cap if it is malfunctioning.

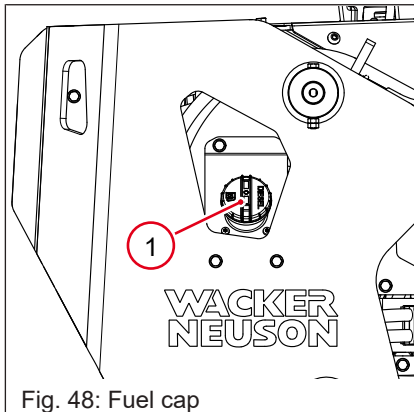

Fig. 48: Fuel cap

6.26 Lift Arm Manual Override



WARNING

Crushing hazard

The lift arm can drop if a sudden pressure loss occurs.

- ▶ Keep others clear of the area when lowering the lift arm.

The lift arm manual override can be used if the machine loses engine power with the lift arm in the raised position.

Procedure

1. Stand on the operator platform and engage the operator presence pedal.

2. Turn the ignition key to Position 1.
3. Press and hold the parking brake switch.
4. Push the right joystick forward to lower the lift arm.

6.27 Lift Arm Support Device



⚠ WARNING

Crushing hazard

A disconnected hydraulic line can result in the lift arm dropping, resulting in serious injury or death.

- ▶ Secure the lift arm support device before working under a raised lift arm.

Maintaining the lift arm support device

Every 250 hours, check the lift arm support device for damage, such as cracking, bending, or excessive rust.

Installing the lift arm support device

1. Lower the lift arm to the ground and remove the attachment.
2. Stop the engine and step off the operator platform.
3. Remove the pin (1) from the lift arm support device (2) and lower the lift arm support device onto the lift cylinder (3).
4. Step onto the platform and start the engine.
5. Raise the lift arm until the lift arm support device drops down over the lift cylinder.
6. Lower the lift arm onto the lift arm support device.
7. Stop the engine and step off the platform.
8. Install the pin to prevent the lift arm support device from moving upward.

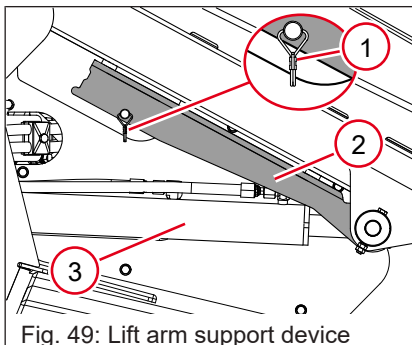

Fig. 49: Lift arm support device

Removing the lift arm support device

1. Start the engine and raise the lift arm to the maximum height.
2. Stop the engine and step off the operator platform.
3. Remove the pin (1) from the lift arm support device (2).
4. Raise the lift arm support device to its storage position and insert the pin.
5. Step onto the platform and start the engine.
6. Slowly lower the lift arm to the ground.
7. Stop the engine and step off the platform.

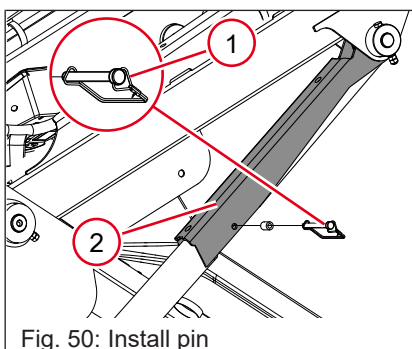

Fig. 50: Install pin

6.28 Parking the Machine

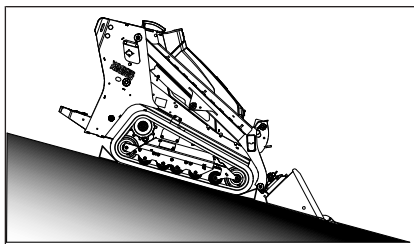

Fig. 51: Parking the machine

1. Park the machine on a level surface with the lift arm completely lowered.
2. If the machine is parked on a slope, position the front of the machine downhill. If possible, tilt the attachment (such as a bucket) down so that it digs into the ground.
3. Engage the parking brake.
4. Allow the engine to cool down at low idle for 5 minutes without any load.
5. Turn the ignition key to the OFF position to stop the engine.
6. Step off the operator platform.
7. Chock the .
8. Make sure the parking brake pins are engaged (at least one).

7 Maintenance

7.1 Maintenance



⚠ WARNING

Personal injury and machine damage hazard

A poorly maintained machine can malfunction, causing injuries or permanent damage to the machine.

- ▶ Keep the machine in safe operating condition by performing periodic maintenance and making repairs as needed.
- ▶ Do not make unauthorized modifications to the machines. This includes structural, hydraulic, engine, and electrical systems.
- ▶ Before returning the machine to service, ensure all covers and parts are installed, check for any fluid leaks, check all fluid levels, operate all controls, and test the loader interlock system functionality.

Unless otherwise specified, the operator can perform the maintenance items listed in this manual. A qualified technician should perform other maintenance and repairs. Repairs can be hazardous if not performed correctly.

Preparing for maintenance work

- Remove all attachments from the machine when service procedures require raising the lift arm. Always secure the lift arm with the lift arm support device.
- Prior to performing maintenance work on the machine, make sure that all interlock devices are engaged to prevent unintended movement on the machine.

Performing maintenance

- If any operating fluid, such as fuel or hydraulic oil, is spraying or leaking, avoid skin contact. High-pressure fuel can penetrate your skin and result in serious injury. If you are exposed to high-pressure fluid spray, seek prompt medical treatment.
- Disassembling or repairing the fuel system must be done by professionals such as the authorized YANMAR distributor or dealer.
- The engine block and exhaust system become very hot during operation and require cool-down time after the machine is shut off. Avoid contact with hot parts.
- After cleaning, examine all fuel, lubricant and hydraulic oil lines for leaks, chafe marks, and damage.
- Do not use the attachment or work equipment as lifting platforms for persons.

7.2 Maintenance Label

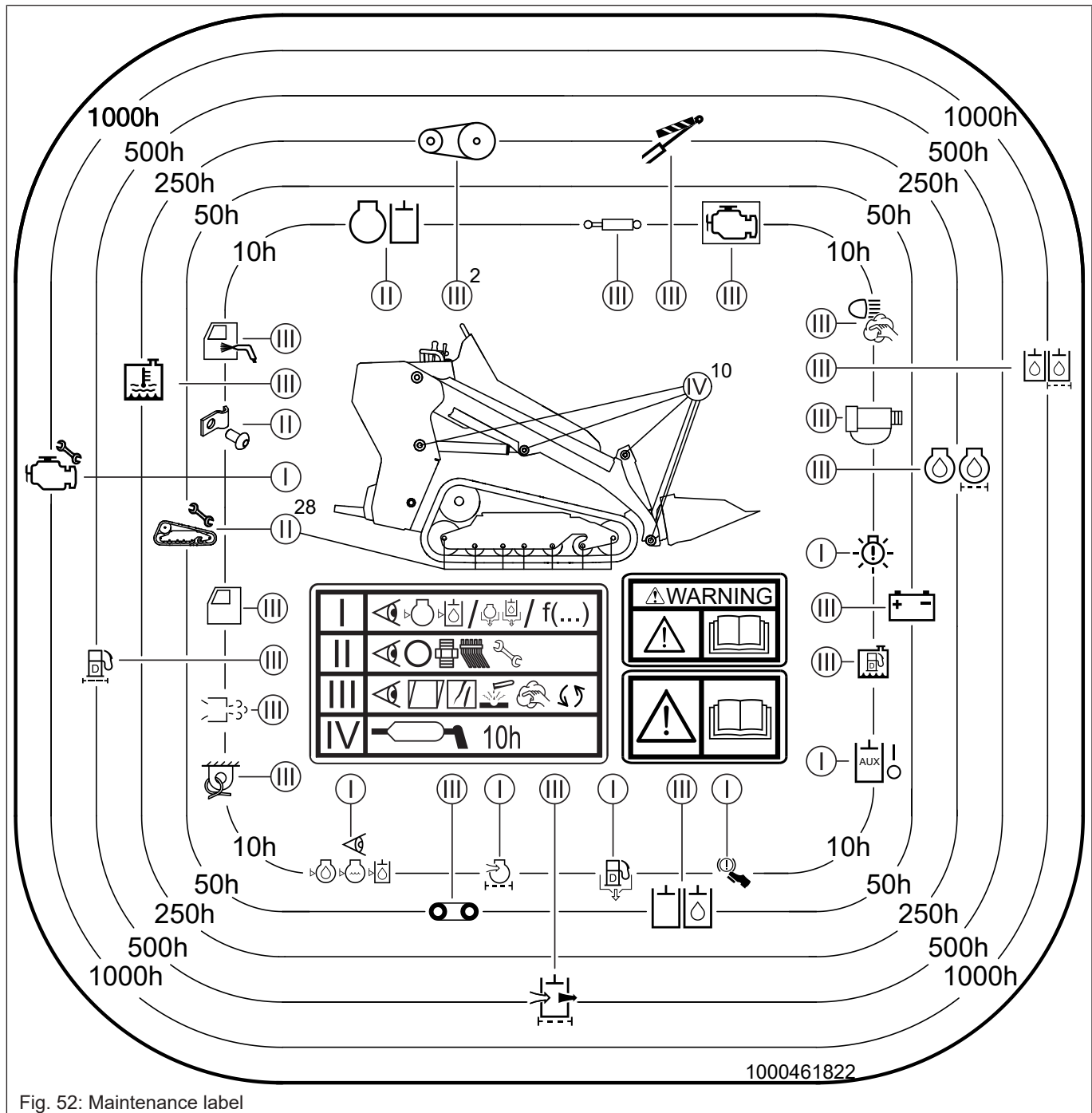
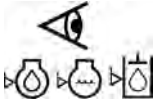

































Fig. 52: Maintenance label

- I Check the functions and fluid levels, filling up and draining.
- II Check parts for wear, seals, hoses, and threaded fittings.
- III Check for damage, corrosion, or dirt. Replace if necessary.
- IV Lubricate daily after operation.

Symbol	Task	Reference
Every 10 Operating Hours (Daily)		
	Check the fluids and lubricants (engine oil, engine coolant, hydraulic oil).	▶ 79 ▶ 75 ▶ 76
	Check the engine air filter condition indicator for leaks and damaged components.	▶ 71
	Check the water separator.	▶ 81
	Lubricate the machine according to the lubrication plan.	▶ 72
	Check the exhaust system for damage.	▶ 82
	Check the service and parking brake function.	▶ 71
	Check the continuous flow shutoff system for proper function.	▶ 83
	Check access panels for dirt.	▶ 71
	Check the piston rods of the cylinders for damage.	▶ 71
	Check the line fixtures.	▶ 71
	Check the indicator lights and acoustic warning devices.	▶ 71
	Check the engine compartment for damage.	▶ 71
	Check the hydraulic couplings for dirt.	▶ 71
	Clean the lights/light system and signaling systems.	▶ 71
	Check the engine and hydraulic system.	▶ 71
	Check the fuel tank level and fill as needed.	▶ 63
	Check the tie-down points for damage.	▶ 71
	Check and clean the operator platform.	▶ 71
—	Check the interlocks for proper function.	▶ 77
—	Check for damaged safety labels. Replace damaged labels.	▶ 71
Only Once after the First 50 Operating Hours		
	Replace engine oil and filter.	▶ 85
	Check condition of all drive belts. Adjust or replace as needed.	▶ 87
Every 50 Operating Hours		
	Check the hydraulic fluid, hoses, and tubelines for damage and leaks. Repair or replace as needed.	▶ 89
	Check the tracks (damage, tension, profile).	▶ 92
	Check the undercarriage for loose bolts and nuts.	▶ 89
—	Drain the water separator.	▶ 81
	Check battery for damage and recharge. Check cables, connections, and electrolyte level.	▶ 98
Every 250 Operating Hours		

Symbol	Task	Reference
	Replace engine oil and filter.	▶ 85
	Check lift arm support device for damage.	▶ 65
	Check condition of all drive belts. Adjust or replace as needed.	▶ 87
	Check and clean radiator fins.	▶ 91
Every 500 Operating Hours (Once a Year)		
	Replace the fuel filter.	▶ 94
—	Clean the water separator.	▶ 81
Every 1000 Operating Hours		
	Replace the hydraulic tank filler cap.	▶ 96
	Replace the hydraulic fluid and filter.	▶ 96
	Check and adjust the engine intake and exhaust valve clearance. ¹⁾	—
Every 2000 Operating Hours		
—	Change coolant. Check and replace coolant hoses. ²⁾	—
—	Check fuel hoses and tubelines for damages and leaks. Repair or replace as needed. ²⁾	—

1) This maintenance task should be performed by a qualified technician. Contact an authorized YANMAR industrial engine dealer or distributor for assistance.

2) This maintenance task should be performed by a qualified technician. Contact an authorized Wacker Neuson dealer or service center for assistance.

7.3 General Daily Checks

- Perform an overall visual check of the machine:
 - Clean dirt and debris from the operator platform.
 - Check for loose and broken parts, instrument operation, and oil leaks.
- Visually inspect the engine compartment, including the engine itself. If you find any problems during the visual check, take the necessary corrective action before operating the engine.
- Visually inspect all hydraulic system components. Check the hydraulic fluid level and check for leaks. For further information, [see Checking the Hydraulic Oil Level on page 76](#) and [see Checking for Leaks on page 78](#).
- With the key switch in Position 1, check the following:
 - Indicator lights—If any indicator fails to illuminate when the key switch is in Position 1, contact an authorized Wacker Neuson dealer or service center for assistance before operating the engine.
 - All other lights, such as work lights
- Check the parking brake for proper function.
- Check the lift arm piston rods for any signs of damage or leakage.
- Check the hydraulic couplings for dirt or debris that may prevent the lines from seating properly.
- Check the attachment coupler for damage. Make sure the pins engage and the lock levers move.
- Check all line fixtures, such as clamps, cable ties, brackets, or other components that secure lines and hoses.
- Check the tie-down points for any damage such as cracks in the weldment.
- Check for damaged safety labels. Replace any damaged safety labels.

7.4 Operating the Hood

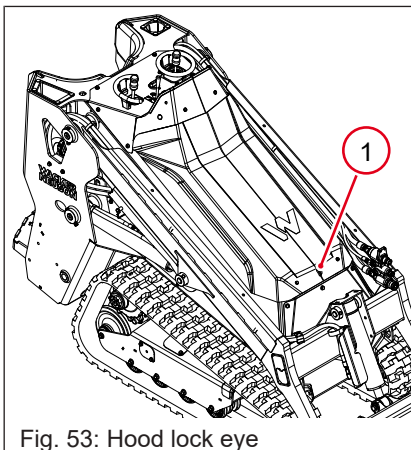

Fig. 53: Hood lock eye

Opening and Closing

1. Remove the lock (if applicable).
2. Pull up to open. (The hood is “locked” in place using rubber door latches.) The hood remains open by itself with a gas strut at the left hood hinge.
3. Lower the hood slowly to make sure the lock eye (**1**) goes through the hole in the hood and the door latches engage properly.
4. Push down firmly to engage the door latches.
5. Install the lock (if applicable).

Adjusting

There are two adjustment points for the hood—one at the right hood hinge **(2)**, and the other at the front bracket **(3)**. The bolt holes are slotted to provide a minimal amount of adjustment. Adjustments at both points are obtained in a similar fashion, as follows:

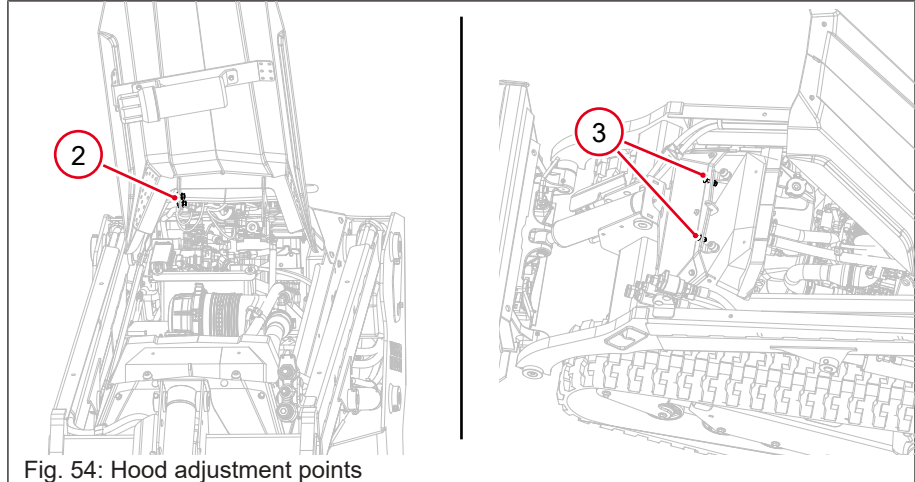

Fig. 54: Hood adjustment points

1. Loosen the carriage bolts that secure the bracket.
2. Adjust the bracket in the desired direction.
3. Tighten the bolts enough to hold the bracket in place and slowly lower the hood to check for proper adjustment.
4. Repeat the previous steps until the correct adjustment is obtained.
5. Tighten the bolts. For standard torque specifications, see [Tightening Torques on page 113](#).

7.5 Lubrication Plan

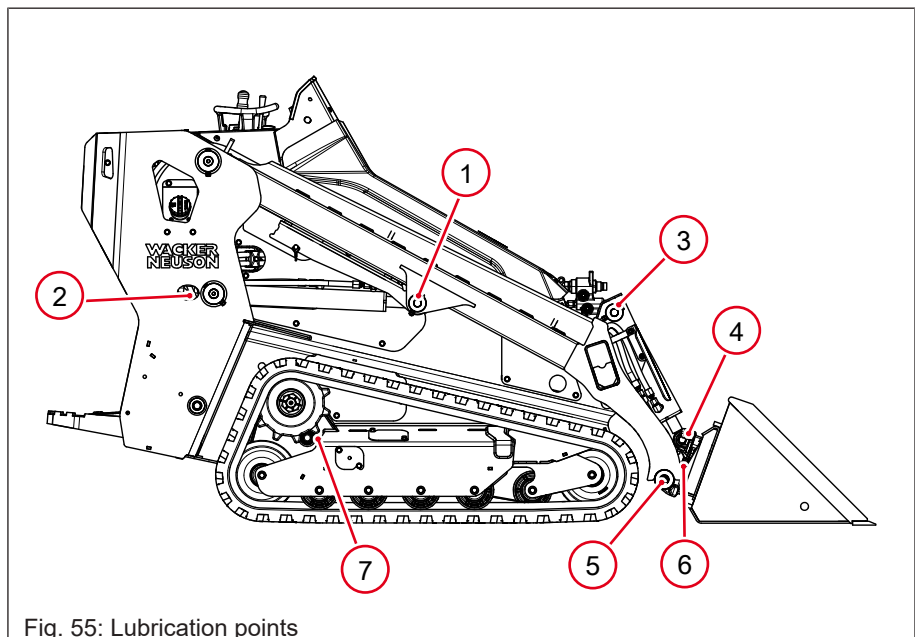
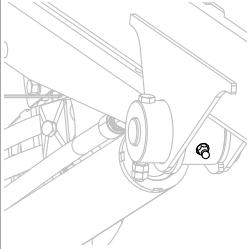

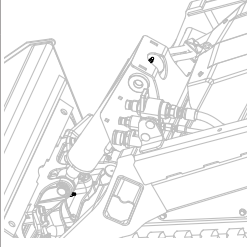
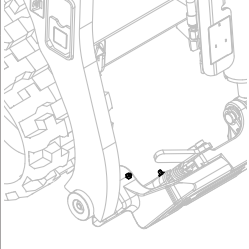
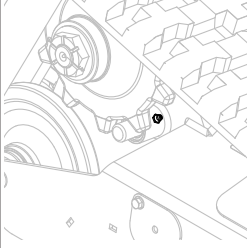

Fig. 55: Lubrication points

Lubricate the specified lubrication points once a day. For the recommended grease to order, see [Maintenance Items on page 11](#).

Position	Location	Lubrication Point	Quantity
1		Lift cylinder (front)	2
2		Lift cylinder (back)	
3		Upper tilt cylinder	1
4		Lower tilt cylinder	
5		Coupler B-pin	2
6		Attachment coupler pin	
7		Brake pin	



7.6 Engine Oil Viscosity



⚠ WARNING

Health hazard

Most used liquids from this machine contain small amounts of materials that can cause cancer and other health problems if inhaled, ingested, or left in contact with skin for prolonged periods of time.

- ▶ Take steps to avoid inhaling or ingesting used liquids.
- ▶ Wash skin thoroughly after exposure to used liquids.

The viscosity of the engine oil is an important factor when determining the correct engine oil to use in your machine. Use an engine oil of appropriate viscosity based on the expected outside air temperature. See the table below.

Oil capacity: 3.4 L (3.6 qt)

The engine oil must meet the API CD, CF, CF-4, CI-4, ACEA E-3, E-E, E-5, or JASO DH-1 standard.

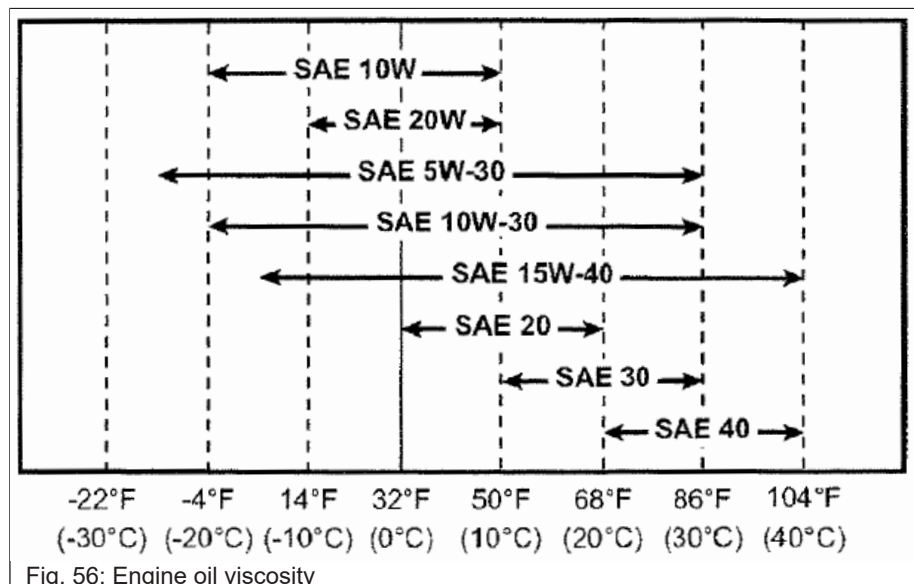

In particularly hot environments where ambient temperatures stay near and over 38°C (100°F), use SAE 15W-40 engine oil.

7.7 Checking and Adding Engine Coolant



⚠ WARNING

Burn hazard

Engine coolant is hot and under pressure at operating temperature. It can cause severe personal injury.

- ▶ Check the engine coolant level only after the engine has been shut down and is cool.
- ▶ Do not add engine coolant directly to the radiator when hot.
- ▶ If you must drain the engine coolant while it is still hot, stay clear of the hot engine coolant to avoid being burned.
- ▶ Check the coolant level at the reserve tank and add coolant as needed.
- ▶ Wear eye protection when handling the engine coolant.
- ▶ Tighten the radiator cap securely after checking the radiator. Steam can escape during engine operation if the cap is loose.



⚠ WARNING

Burn hazard

Engine coolant can contain alkali.

- ▶ Avoid engine coolant contact with skin and eyes.

When

Every 10 hours or daily

Requirements

- Machine parked on a level surface
- Machine shut down and cool to the touch
- If needed, an equal mix (50/50) of distilled water and ethylene glycol organic acid technology (OAT) long life coolant concentrate

Overview

The engine coolant recovery reserve tank is located on the ride side of the engine compartment.

Procedure

1. Check that the engine coolant level is between the min and max lines (1).

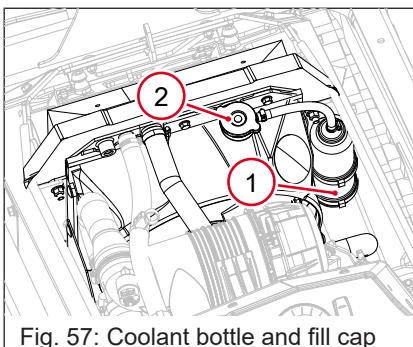

Fig. 57: Coolant bottle and fill cap

2. If the engine coolant level is below the min line or above the max line, remove the recovery reserve tank cap **(2)**.
 - ⇒ If the engine coolant level is below the min line, fill the tank with coolant until the engine coolant level is between the min and max lines.
 - ⇒ If the engine coolant level is above the max line, use a siphon to remove coolant from the recovery reserve tank until the level is just at or below the max line.
3. Install the recovery reserve tank cap.
4. Close the rear door.

7.8 Checking the Hydraulic Oil Level



Environment

Use a suitable container to collect, store, and dispose of drained fluids and lubricants in accordance with current environmental protection regulations.

When

Every 10 hours or daily

Requirements

- Machine parked on a level surface
- Machine shut down
- Lift arm down
- New hydraulic oil as needed

Overview

The hydraulic oil filler cap and sight glass are located on the left side of the machine.

Procedure

1. Observe the hydraulic oil level through the sight glass **(1)**. The hydraulic oil level should be half full in the sight glass.
2. If the oil level is low, remove the hydraulic fill access plate by removing the retaining bolt **(2)** and loosening the pivot bolt **(3)**.
3. Rotate the access plate out of the way.

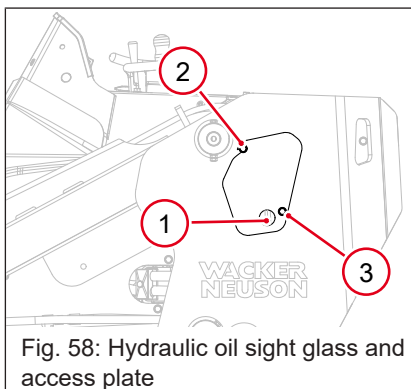

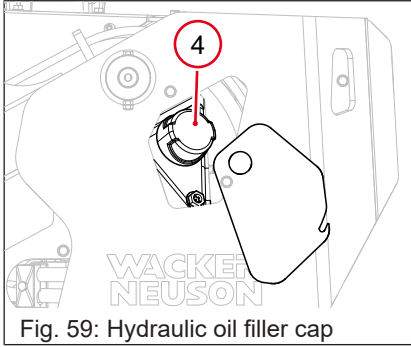

4. Clean the area around the hydraulic tank filler cap (4).
5. Remove the hydraulic tank filler cap and fill the hydraulic oil to a level half full in the sight glass.
6. Rotate the access plate into place and tighten the bolts.

7.9 Testing the Control Interlock System

When

Every 10 hours or daily

Procedure

To enable the ground drive, loader lift and tilt, and auxiliary hydraulics, the operator must complete all of the following actions:

1. Stand on the operator platform and engage the operator presence pedal.
2. Start the engine.
3. Disengage the parking brake.

To test the control interlock system, perform the following functions individually with the engine running and the controls enabled. A successful test means that the machine will not move after each of the following tests are performed:

- Disengage the operator presence pedal, wait 5 seconds, and move the ground drive controls, lift arm controls, and auxiliary hydraulic controls.
- With operator presence pedal engaged, disengage the parking brake and move the ground drive control only.

Note: After all controls are enabled, pressing the brake switch will only engage the parking brake and limit the ground drive controls to hold the machine stationary. This allows the machine to operate the lift arm controls or auxiliary controls while preventing the machine from moving—for example, drilling a post hole while working on a slope.

Testing the lift arm controls interlock

1. Stand on the operator platform with the operator presence pedal engaged and start the engine.
2. Raise the lift arm slightly off the ground.
3. Shut down the machine and wait for the engine to stop completely.
4. Make sure the area around the machine is clear.
5. Move the right joystick forward to lower the lift arm.
 - ⇒ The lift arm should not lower.

6. Move the right joystick to the right to tilt the bucket or attachment forward.
⇒ The bucket or attachment should not tilt forward.

Testing the auxiliary controls interlock

1. Shut down the machine.
2. Make sure the area around the machine is clear.
3. Set the throttle to the low idle position.
4. Push the auxiliary hydraulic control lever forward and hold it in place.
5. Turn the key switch to Position 2 to start the engine.
⇒ The starter should not engage.
6. Repeat 5 and 6 with the auxiliary hydraulic control lever pulled backward.

7.10 Checking for Leaks



⚠ WARNING

Fire hazard

Flammable liquids and residue can easily ignite when exposed to flame.

- ▶ Never use an open flame to inspect for leaks.



⚠ WARNING

Risk of injury due to pressure!

A fine jet of hydraulic oil under high pressure can penetrate through the skin. This can cause serious injury.

- ▶ Wear protective gloves and safety glasses.
- ▶ Never search for leaks with your bare hands.
- ▶ Search for leaks using a piece of cardboard or paper on which the escaping oil can be seen.
- ▶ Seek medical attention immediately if hydraulic oil penetrates the skin or eyes.

When

Every 50 hours

Requirements

- Flashlight or shielded light (never use an open flame)
- Protective gloves
- A piece of cardboard, wood, or a mirror

Overview

Regular checks for leaks are essential for keeping the machine in serviceable condition. It is important to identify and repair leaks as soon as possible to maintain proper machine operation and prevent slip and fall hazards, fire danger, and environmental contamination.

Procedure

When checking for leaks, use a flashlight or other shielded light.

1. Thoroughly inspect for damage:
 - ⇒ Check for cracks, dents, bends, or deformation of plates and welds.
 - ⇒ Check for broken, loose, or missing parts, such as nuts, bolts, and brackets.
 - ⇒ Inspect all hydraulic hoses for signs of wear or cracks and replace if needed.
 - ⇒ **Note:** Hardware should be replaced with OEM parts and should be tightened to the manufacturer's recommendations.
2. Check for fuel, engine oil, hydraulic oil, and other leaks.
 - ⇒ To locate a leak, pass a piece of cardboard, wood, or a mirror over the area of the suspected leak.
3. Fix the leak before operating the machine.
4. Secure all caps and filler plugs for all systems to prevent leaks from these areas.

7.11 Checking the Engine Oil



⚠ WARNING

Health hazard

Most used liquids from this machine contain small amounts of materials that can cause cancer and other health problems if inhaled, ingested, or left in contact with skin for prolonged periods of time.

- ▶ Take steps to avoid inhaling or ingesting used liquids.
- ▶ Wash skin thoroughly after exposure to used liquids.



NOTICE

Engine damage can occur if the oil level is too high or if the incorrect oil is used.

- ▶ Oil must be removed from the engine if the oil level is above the max line.
- ▶ Use only the recommended oil.



NOTICE

Prevent dirt and debris from contaminating the engine oil. Carefully clean the oil cap, dipstick, and the surrounding area before removing the cap.

Do not mix different types of engine oil. This can adversely affect the lubricating properties of the engine oil.



Environment

Use a suitable container to collect, store, and dispose of drained fluids and lubricants in accordance with current environmental protection regulations.

When

Every 10 hours or daily

Requirements

- Machine parked on a level surface
- Machine shut down and cool to the touch
- Recommended oil (for oil specifications, [see Engine Oil Viscosity on page 74](#) and [see Fluids on page 110](#))
- A clean, soft cloth

Overview

Maintaining the appropriate engine oil prevents excessive engine wear.

Procedure

1. Open the engine door and protect yourself from engine heat.
2. Carefully remove the dipstick **(1)** and wipe it clean.
3. Fully insert the dipstick into the dipstick tube **(2)** and remove it again to check the engine oil level.
4. If the engine oil level is between the min **(3)** and max **(4)** marks, the level is acceptable. Do not add engine oil.
5. If the oil level is below **(5)** the min mark, remove the engine oil cap **(6)** and add enough oil to raise the level within the min-max range.
 - ⇒ Repeat steps 1, 2, and 3 to check engine oil level.
 - ⇒ Install engine oil cap when engine oil level is sufficient.
6. Install the dipstick and close the engine door.

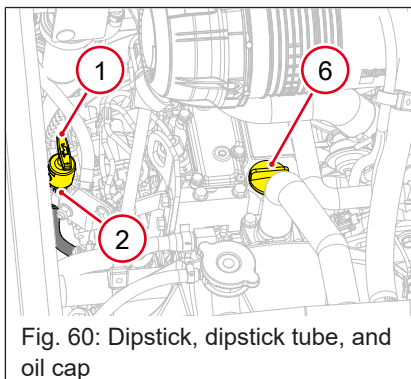

Fig. 60: Dipstick, dipstick tube, and oil cap

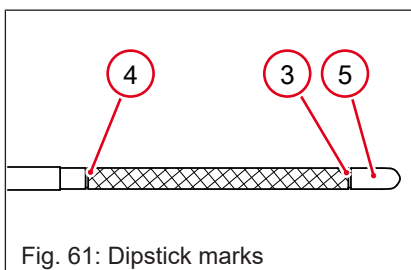

Fig. 61: Dipstick marks

7.12 Draining and Cleaning the Water Separator



Environment

Use a suitable container to collect, store, and dispose of drained fluids and lubricants in accordance with current environmental protection regulations.

When

- Every 10 hours or daily—check
- Every 50 hours—drain
- Every 500 hours—clean

Requirements

- Machine shut down
- Container of sufficient volume to collect drained fluid
- Filter wrench

Removing the water separator

The water separator (1) is located in the engine compartment.

1. Raise the lift arm and secure the lift arm support device. For further information, see [Lift Arm Support Device on page 65](#).

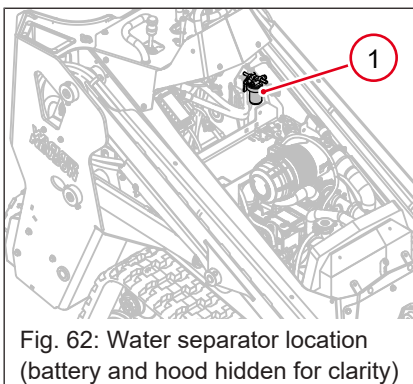

Fig. 62: Water separator location (battery and hood hidden for clarity)

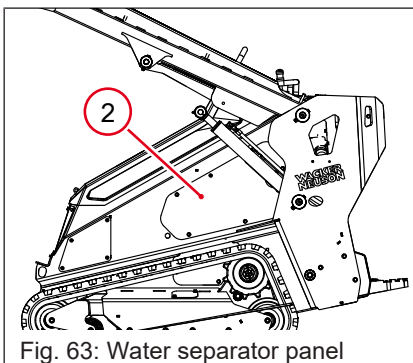

Fig. 63: Water separator panel

2. Remove the side panel (2) next to the water separator.
3. Place a container beneath the water separator.
4. Clean the area of the filter cartridge and housing.



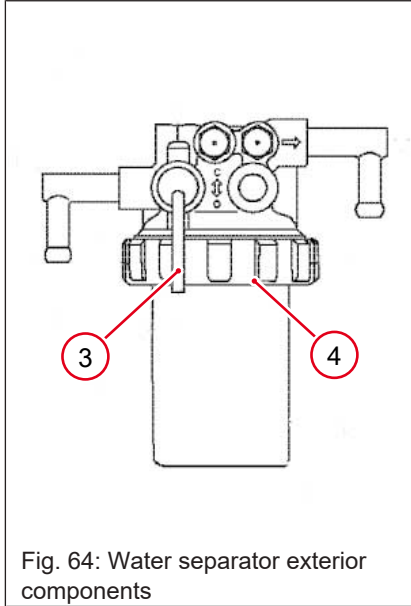

Fig. 64: Water separator exterior components

5. Interrupt the fuel supply by turning the fuel valve (3) 180° to the CLOSED (up) position.
6. Unscrew the threaded fitting (4) using an appropriate filter wrench, if necessary.
7. Carefully remove the cartridge. Clean up any spills immediately.

Draining the water separator

1. Pour the fuel and water mixture into an approved container and dispose of waste properly.
2. Wait until the indicator ring returns to the bottom of the water separator.
3. Reinstall the cartridge and hand-tighten the threaded fitting.

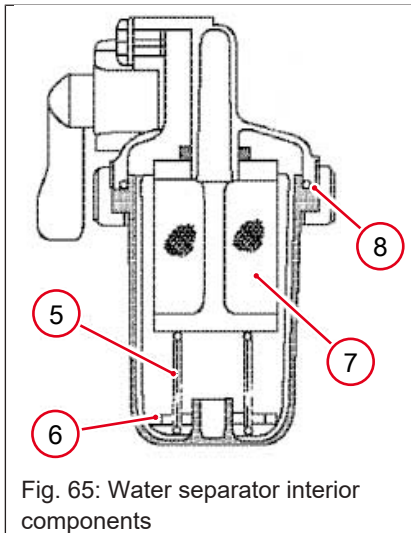

Fig. 65: Water separator interior components

Cleaning the water separator

1. Remove the retaining spring (5) and indicator ring (6) from the cartridge.
2. Pour the fuel and water mixture into an approved container and dispose of waste properly.
3. Clean the inside of the cartridge.
4. Check the filter (7) for debris. Clean the filter mesh if necessary.
5. Check the O-ring (8) for damage. Replace the O-ring if necessary.
6. Place the indicator ring and retaining spring back inside the cartridge.
7. Reinstall the cartridge and hand-tighten the threaded fitting.
8. Open the fuel supply by turning the fuel valve to the OPEN (down) position.
9. Prime the fuel system by turning the key switch to the ON position (Position 1) for 10 to 15 seconds.
10. Check for any fuel leaks.

7.13 Checking the Exhaust System

When

Every 10 hours or daily

Requirements

- Machine shut down
- Exhaust pipes and muffler cool to the touch

Overview

A leaky exhaust system adversely affects machine operation. Symptoms include increased noise and visible soot deposits. Leaking exhaust can also ignite surrounding materials and pipe insulation, causing a fire.

Procedure

1. Open the hood.
2. Inspect the exhaust pipes **(1)** and muffler **(2)**, looking for:
 - ⇒ Cracks or holes
 - ⇒ Loose or missing clamps
 - ⇒ Black soot deposits, especially around welds and joints
3. Start the engine. Listen carefully for:
 - ⇒ Excessive noise. Some noise is normal when the engine starts or shuts down as the engine mount contacts with stop blocks.
 - ⇒ Rumbling
 - ⇒ High-pitched whine
 - ⇒ Rattling
4. Repair or replace faulty components before putting the machine back into service.

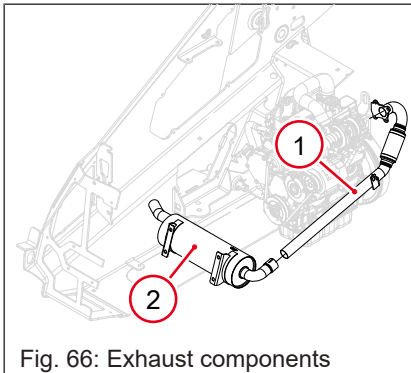

7.14 Checking the Continuous Flow Shutoff System

When

Every 10 hours or daily

Requirements

- Machine shut down
- Area clear of bystanders

Procedure

1. Set the throttle **(1)** to the low idle position.
2. Turn the ignition key **(2)** to Position 1.
3. Press the continuous flow switch **(3)**. The switch illuminates when it is engaged.
4. Push the auxiliary hydraulic control lever **(4)** fully forward.
5. Press the continuous flow switch again.
 - ⇒ The auxiliary hydraulic control lever should return to the NEUTRAL position.
6. Repeat steps 3–5 with the auxiliary hydraulic control lever pulled fully backward.

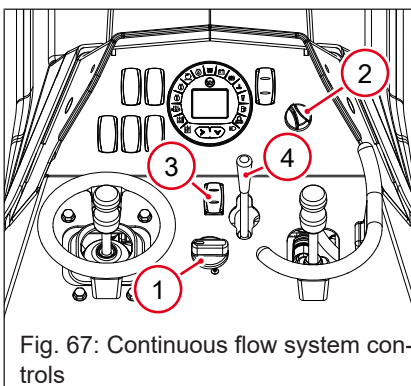

If the continuous flow system does not function properly, contact an authorized Wacker Neuson dealer or service center for assistance.

7.15 Cleaning the Machine



⚠ CAUTION

Personal injury hazard

Using compressed air or high-pressure water may cause eye injuries due to flying debris, dust, and steam.

- ▶ Wear eye protection when using compressed air or high-pressure water.



NOTICE

A pressure washer can damage the electrical system, damage seals, and disable the controls.

- ▶ Do not clean the inside of the machine using a pressure washer.



NOTICE

Direct, high water pressure at close range will damage certain components on the machine. The following components should be wiped clean by hand using a damp, clean cloth. Do not apply high pressure spray to these components:

- ▶ Oil cooler, fan, and connecting hoses
- ▶ Hydraulic manifold
- ▶ Fuse boxes
- ▶ Electronic parts (controller, connectors, etc.)
- ▶ Alternator
- ▶ Radiator core
- ▶ Labels

When

- Daily after each use—entire machine
- Every 250 hours—radiator fins ([see Checking and Cleaning the Radiator Fins on page 91](#))

Requirements

- Machine shut down and cool to the touch
- Clean water supply
- Pressure washer or water hose
- Clean, soft cloths

Overview

Regular cleaning is essential for keeping the machine in serviceable condition. It is important to remove dust and dirt from the machine as soon as possible after work has been completed.

Procedure

1. Use a pressure washer or water hose to remove dirt and debris from the machine's exterior.
 - ⇒ To pressure wash areas with labels, direct the water stream at a 90° angle to the machine surface with the spray nozzle at least 1/3 m (1 ft) away.
2. Keeping a minimum distance of 1 m (3 ft) away, use the pressure washer to rinse the machine.
3. Clean interior and electronic machine components using a damp, clean cloth.

7.16 Changing the Engine Oil and Filter



▲ WARNING

Health hazard

Most used liquids from this machine contain small amounts of materials that can cause cancer and other health problems if inhaled, ingested, or left in contact with skin for prolonged periods of time.

- ▶ Take steps to avoid inhaling or ingesting used liquids.
- ▶ Wash skin thoroughly after exposure to used liquids.



NOTICE

Engine damage can occur if the oil level is too high or if the incorrect oil is used.

- ▶ Oil must be removed from the engine if the oil level is above the max line.
- ▶ Use only the recommended oil.



NOTICE

Prevent dirt and debris from contaminating the engine oil. Carefully clean the oil cap, dipstick, and the surrounding area before removing the cap.

Do not mix different types of engine oil. This can adversely affect the lubricating properties of the engine oil.



Environment

Use a suitable container to collect, store, and dispose of drained fluids and lubricants in accordance with current environmental protection regulations.

When

- After the first 50 hours
- Every 250 hours

Requirements

- Machine parked on a flat, level surface
- Machine shut down
- Replacement genuine YANMAR oil filter
- Container of sufficient volume to collect drained fluid
- Recommended oil (for oil specifications, [see Engine Oil Viscosity on page 74](#) and [see Fluids on page 110](#))
- Filter wrench

Procedure

1. Loosen the two bolts **(1)** securing the access cover **(2)** on the right side of the machine.
2. Swivel the access cover out of the way and tighten the top left bolt if necessary to hold it in place.

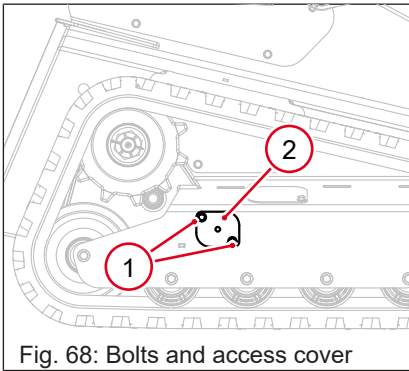

3. Pull the oil drain hose **(3)** out from the access hole.
4. Drain the oil into a suitable container by removing the cap from the oil drain hose.

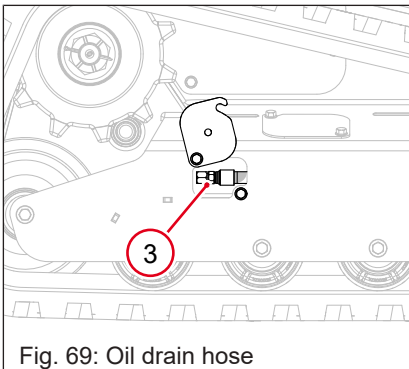

5. Remove the three bolts **(4)** securing the cover plate **(5)**.
6. Place a suitable container under the oil filter to catch used oil.

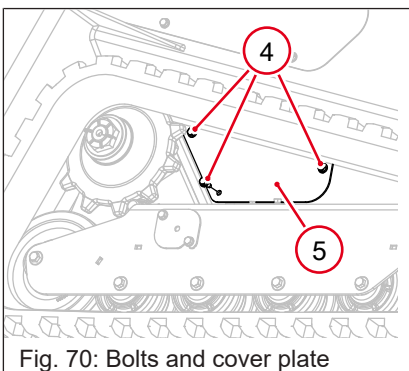

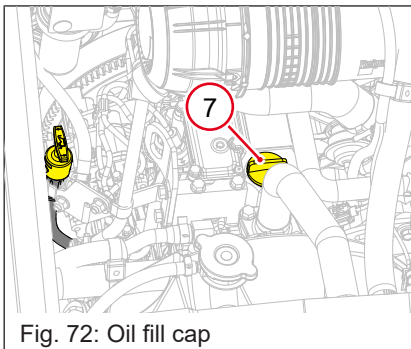
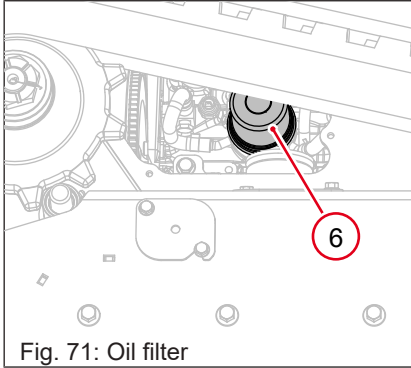

7. Remove the oil filter **(6)**.
8. Install a new oil filter.
9. Install the cap on the oil drain hose.
10. Open the hood.
11. Remove the oil fill cap **(7)** from the engine.
12. Fill the engine with the required amount of oil.
13. Install the oil fill cap.
14. Start the engine and check for leaks.
15. Stop the engine.
16. Install the cover plate **(5)**.
17. Push the oil drain hose **(3)** in the back into the access hole.
18. Place the access cover **(2)** in its closed position and tighten the bolts **(1)**.

7.17 Checking and Adjusting the Drive Belts



⚠ WARNING

Personal injury hazard

Checking the belt tension while the engine is running may cause personal injury.

- ▶ Shut off the engine before carrying out work in the engine compartment.
- ▶ Shut off the power supply.
- ▶ Let the engine cool down.

When

- After the first 50 hours
- Every 250 hours

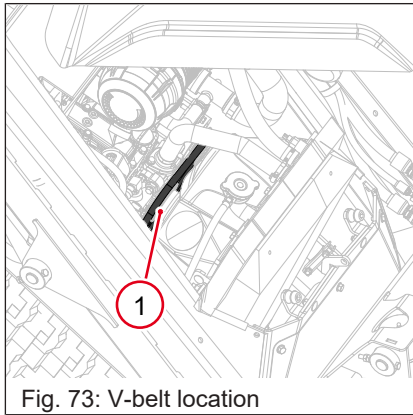

Fig. 73: V-belt location

Checking the cooling fan V-belt

1. Open the hood.
2. Check the belt (1) tension using a belt tension gauge or by pressing the belt down with your thumb. Check the tension in whichever position (A, B, or C) is most accessible.

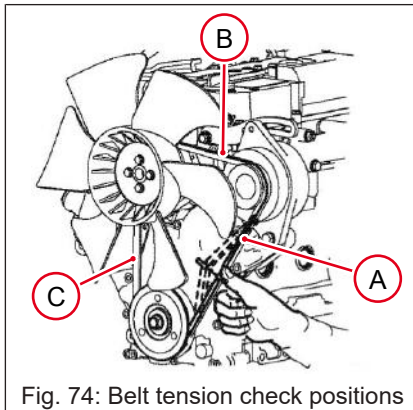

Fig. 74: Belt tension check positions

3. Check the tension values in the applicable table below.
Note: A “used” V-belt is a belt that has been used on a running engine for five minutes or more.
4. Check the belt condition.
5. Adjust the tension or replace the belt as needed.

New V-belt Tension		
A	B	C
8–12 mm (5/16–7/16 in.)	5–8 mm (3/16–5/16 in.)	7–11 mm (1/4–7/16 in.)

Used V-belt Tension		
A	B	C
10–14 mm (3/8–1/2 in.)	7–10 mm (1/4–3/8 in.)	9–13 mm (5/16–1/2 in.)

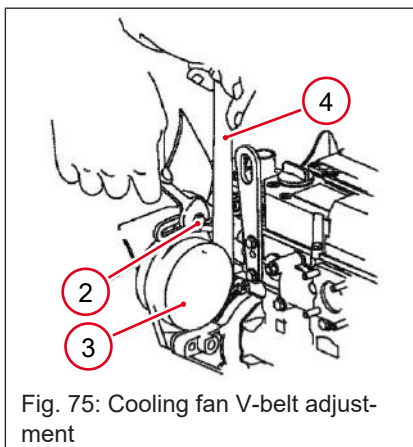

Fig. 75: Cooling fan V-belt adjustment

Adjusting the cooling fan V-belt

1. Loosen the alternator adjusting bolt (2) and any other related fasteners.
2. Adjust the belt tension by pivoting the alternator (3) in or out using a pry bar (4).
3. Tighten the alternator adjusting bolt and related fasteners and check the belt tension.

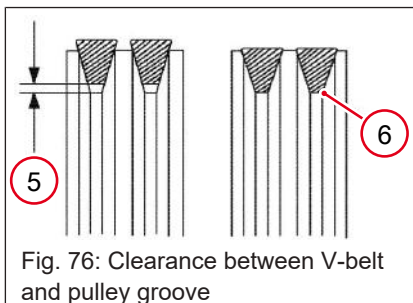

Fig. 76: Clearance between V-belt and pulley groove

4. Repeat these steps until you achieve the desired belt tension.
⇒ There must be clearance (5) between the V-belt and the bottom of the pulley groove. If there is no clearance (6) between the V-belt and the bottom of the pulley groove, replace the V-belt.
5. After adjusting the tension, run the engine for at least 5 minutes. Check the tension again using the specifications for a used V-belt.

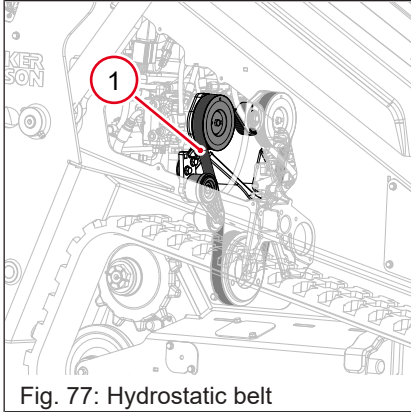

Fig. 77: Hydrostatic belt

Checking the hydrostatic drive belt

Over the life of the machine, the hydrostatic drive belt **(1)** will stretch in length and need to be adjusted. The hydrostatic drive belt may also slip during high hydraulic load events.

In these cases, follow the procedure below to add tension to the belt:

1. Raise the lift arm and install the lift arm support device. For further information, [see Lift Arm Support Device on page 65](#).
2. Remove the right side panel.
3. Loosen but do not remove the two screws **(2)** securing the tensioner.
4. Using a standard 3/8 in. socket driver, rotate the adjustable tensioner spacer **(3)** counterclockwise until the end of travel is reached.
5. While holding the tensioner spacer in place, retighten the screws.

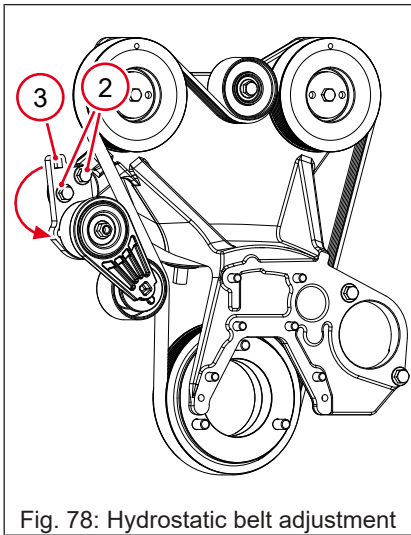

Fig. 78: Hydrostatic belt adjustment

7.18 Checking the Undercarriage

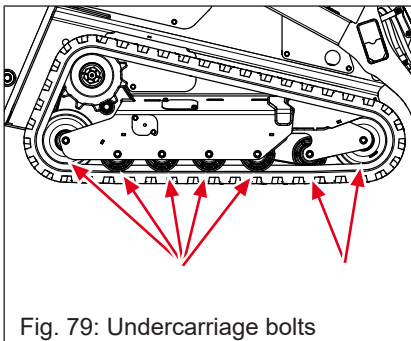

Fig. 79: Undercarriage bolts

When

Every 50 hours

Procedure

- Check for loose bolts and nuts as shown. For standard torque specifications, [see Tightening Torques on page 113](#).
- Check the condition of the cotter pin on the sprocket castle nut.

7.19 Inspecting Hoses and Hard Lines

When

Every 50 hours

Procedure

Inspect hoses and lines periodically (at least weekly) for signs of wear. Observe the following:

- Look for leakage or seepage along the entire length of the hose/line, especially at the ends.
- Check hose clamps for damage.
- Look for rust on metal lines.
- Hoses should be firm and springy. Hoses that are cracked, soft, covered in oil, or otherwise obviously damaged should be replaced.

7.20 Servicing the Air Cleaner



⚠ WARNING

Fire hazard

Flammable liquids pose a fire hazard when cleaning.

- ▶ Do not use gasoline or other types of low flash point solvents to clean the air cleaner.



NOTICE

Foreign material entering the engine may damage it.

- ▶ Do not operate the engine with the air cleaner elements removed.



NOTICE

Compressed air can damage air filter elements.

- ▶ Do not use compressed air to clean the air filter elements.

When

Every 10 hours or daily, check the air filter restriction indicator  on the display. Replace the air filter when the indicator is illuminated.

Requirements

- Machine parked on a level surface
- Machine shut down and cool to the touch
- Damp cloth

Overview

The air cleaner is located in the engine compartment.

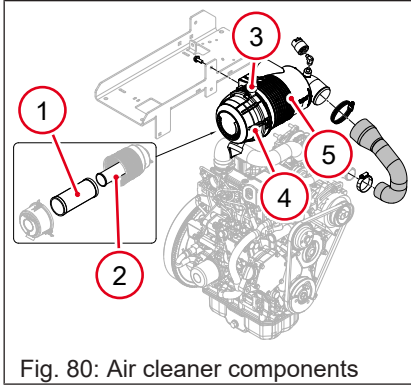

Fig. 80: Air cleaner components

Procedure

If the outer air filter element (1) is excessively dirty, replace it. Replace the inner air filter element (2) every third time the outer air filter element is replaced. Check for any signs of leaks or damaged components throughout this process.

1. Release the latch (3) and remove the cover (4) from the air cleaner housing (5).
2. Remove the outer air filter element from the air cleaner housing. If necessary, also remove the inner air filter element.
3. Clean the inside of the air cleaner housing components with a damp cloth.
4. Install the air filter elements and the cap.
5. Install the cover and fasten the latch.

7.21 Checking and Cleaning the Radiator Fins



CAUTION

Personal injury hazard

Using compressed air or high-pressure water may cause eye injuries due to flying debris, dust, and steam.

- ▶ Wear eye protection when using compressed air or high-pressure water.



NOTICE

Cleaning the radiator improperly will damage the radiator fins.

- ▶ Do not use high-pressure water or compressed air at a pressure greater than 28 psi (193 kPa).
- ▶ Do not use a wire brush.

When

Every 250 hours

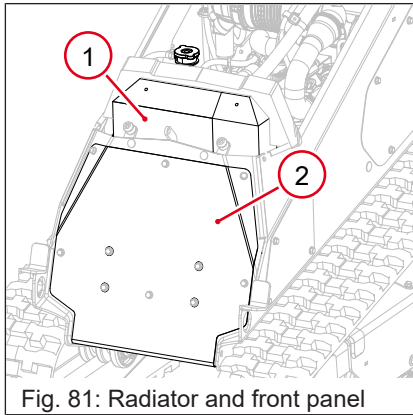

Checking and cleaning the radiator fins

1. Stop the engine.
2. Open the hood.
3. Use compressed air to clean loose dirt and debris from the radiator (1).
Note: The front panel (2) can be removed for easier and better access to the radiator. Before removing the panel, raise the lift arm and install the lift arm support device. For more information, see [Lift Arm Support Device](#) on page 65.
4. Use a low pressure water stream to clean dirt from the surface of the radiator.

7.22 Checking and Adjusting Track Tension



⚠ WARNING

Personal injury hazard

Grease escaping under pressure can penetrate the skin and cause serious injury or death.

- ▶ Open the lubricating valve very carefully.
- ▶ Wear protective gloves and safety glasses.
- ▶ Release grease only as described below.
- ▶ Contact a Wacker Neuson service center if this does not reduce track tension.



Environment

Use a suitable container to collect, store, and dispose of drained fluids and lubricants in accordance with current environmental protection regulations.

When

Every 50 hours

Requirements

- Machine parked on a level surface
- Machine shut down
- Plastic sheet to protect work surface
- Floor jack and jack stands
- Wrench
- Grease gun

Overview

Track wear can vary depending on the type of work and ground conditions.

Checking track tension

1. Raise the machine using a floor jack and jack stands.
 ⇒ Be careful not to position the jack stands over the belly pan cover.
2. Adjust the track tension if the track sag distance between the bottoms of the two middle rollers and the track is between 15 and 18 mm (0.56 and 0.71 in.).

Increasing track tension

1. On the side of the machine that needs its track adjusted, loosen the screws (1) securing the grease valve cover and swing the cover (2) down.

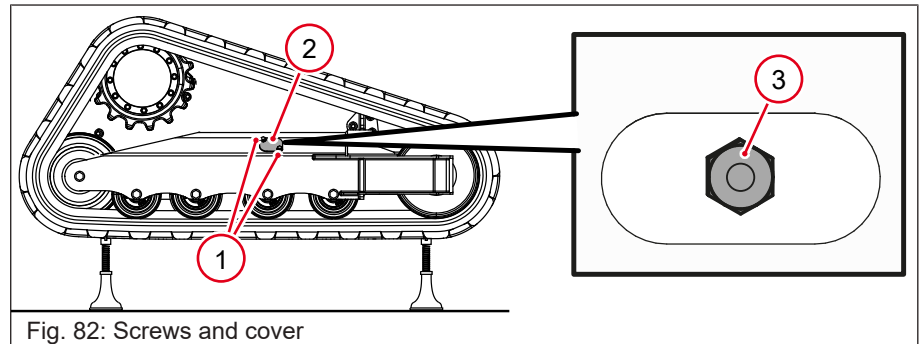

2. Apply grease into the valve (3) with a grease gun.
3. Check the track tension again. The track sag distance between the bottoms of the two middle rollers and the track should be between 15 and 18 mm (0.56 and 0.71 in.). If the track tension is still out of specification, apply more grease into the valve.
4. If the track still does not have enough tension after applying grease again, do not put the machine into operation. Contact a Wacker Neuson dealer.
5. Lower the machine to the ground.
6. Install the cover.

Reducing track tension

1. On the side of the machine that needs its track adjusted, loosen the screws securing the grease valve cover and swing the cover down.
2. Slowly turn the valve counterclockwise to release the grease into a suitable container.
 ⇒ The grease flows out of the groove of the valve.
3. Tighten the valve until it is snug.
4. Check the track tension again. The track sag distance between the bottoms of the two middle rollers and the track should be between 15 and 18 mm (0.56 and 0.71 in.). If the track tension is still out of specification, repeat the procedure for increasing or reducing track tension as needed.

5. If the track still does not have enough tension after applying grease again, do not put the machine into operation. Contact a Wacker Neuson dealer.
6. Lower the machine to the ground.
7. Install the cover.

7.23 Replacing the Fuel Filter



⚠ WARNING

Explosion and fire hazard when handling fuel!

Can cause serious burns or death.

- ▶ Bleed the fuel system only if the engine is cold.
- ▶ Wear protective equipment.
- ▶ Never perform work on the fuel system near open flames or sparks.
- ▶ Do not smoke.
- ▶ Keep the maintenance area clean.



Environment

Use a suitable container to collect, store, and dispose of drained fluids and lubricants in accordance with current environmental protection regulations.

When

Every 500 hours

Requirements

- Replacement genuine YANMAR fuel filter
- Container of sufficient volume to collect drained fluid

Procedure

1. Raise the lift arm and install the lift arm support device. For more information, [see Lift Arm Support Device on page 65](#).
2. Shut down the machine.
3. Allow the machine to cool for at least 5 minutes.
4. Lift the hood.
5. Interrupt the fuel supply by turning the fuel valve **(1)** 180° to the CLOSED (up) position on the water separator **(2)**.

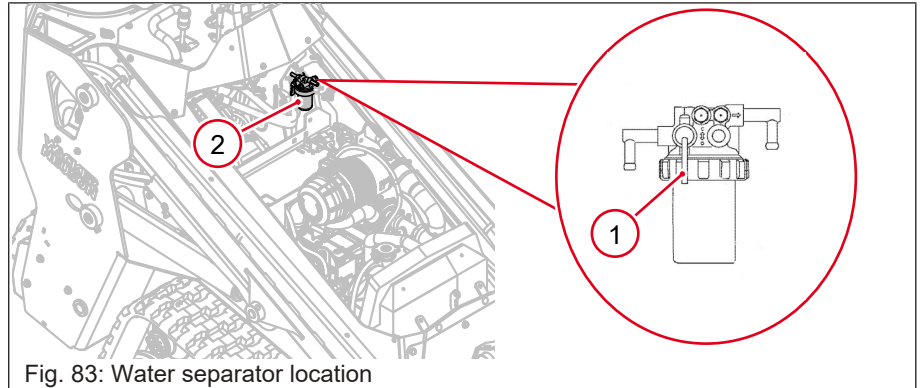

Fig. 83: Water separator location

6. Remove the side panel next to the fuel filter.
7. On the fuel filter (3), unscrew the threaded fitting (4) using an appropriate filter wrench, if necessary.

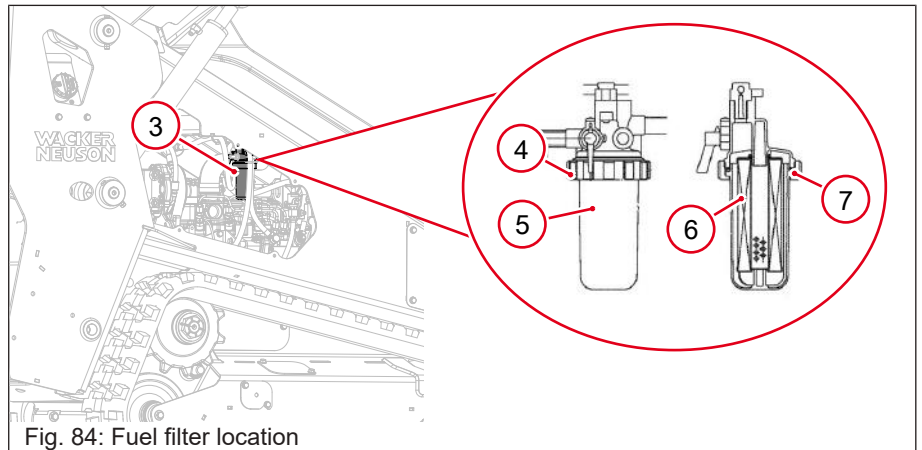

Fig. 84: Fuel filter location

8. Carefully remove the cartridge (5). Clean up any spills immediately.
9. Pour the fuel into an approved container and dispose of waste properly.
10. Remove the fuel filter element (6).
11. Install the new fuel filter element.
Note: Do not fill the new fuel filter with fuel.
12. Clean the inside of the cartridge.
13. Check the O-ring (7) for damage. Replace the O-ring if necessary.
14. Reinstall the cartridge and hand-tighten the threaded fitting.
15. Open the fuel supply fuel by turning the fuel valve to the OPEN (down) position on the water separator.
16. Prime the fuel system by turning the key switch to the ON position (Position 1) for 10 to 15 seconds.
17. Check for any fuel leaks.

7.24 Replacing the Hydraulic Tank Filler Cap

When

Every 1000 hours

Requirements

- Machine parked on a flat, level surface
- Machine shut down

Procedure

1. Remove the hydraulic fill access plate **(1)** by removing the retaining bolt **(2)** and loosening the pivot bolt **(3)**.
2. Rotate the access plate out of the way.
3. Remove the old hydraulic tank filler cap **(4)**.
4. Install the new hydraulic tank filler cap.
5. Rotate the access plate back into place.
6. Install the retaining bolt.
7. Tighten the pivot bolt.

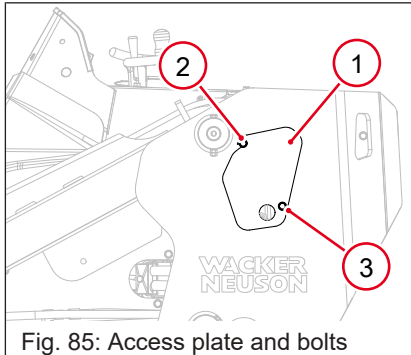

Fig. 85: Access plate and bolts

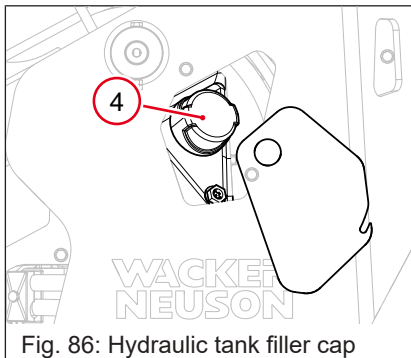

Fig. 86: Hydraulic tank filler cap

7.25 Replacing the Hydraulic Fluid and Filter

When

Every 1000 hours, or as indicated by the display

Requirements

- Machine parked on a flat, level surface
- Machine shut down
- Replacement fluid
- Replacement filter

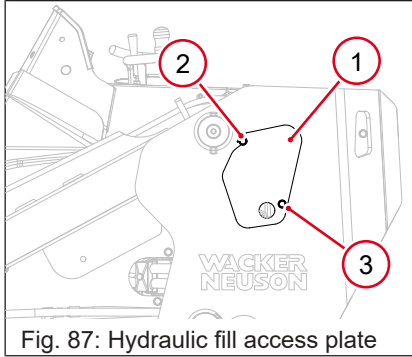

Replacing the hydraulic oil

1. Remove the hydraulic fill access plate (1) by removing the retaining bolt (2) and loosening the pivot bolt (3).
2. Rotate the access plate out of the way

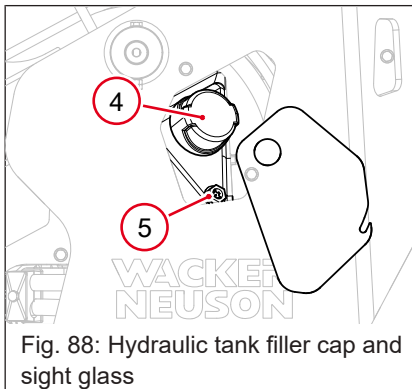

3. Remove the hydraulic tank filler cap (4).
4. Insert a suction hose into the fill tube to remove the hydraulic fluid.
5. Add the replacement hydraulic fluid to the reservoir until the fluid level is half full in the reservoir sight glass (5).
6. Install the hydraulic tank filler cap.
7. Start the engine and operate the hydraulic controls.
8. Stop the engine and check for leaks.
9. Observe the hydraulic oil level through the sight glass and add fluid as needed.

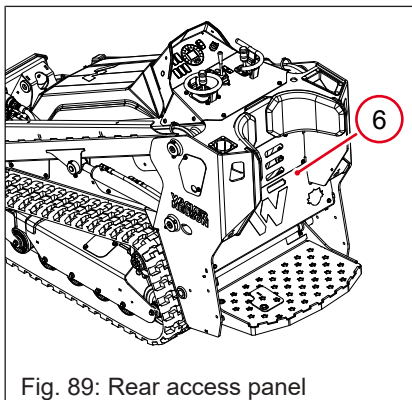

Replacing the hydraulic filter

1. Remove the rear access panel (6).
2. Place a suitable container under the filter to catch any fluid.

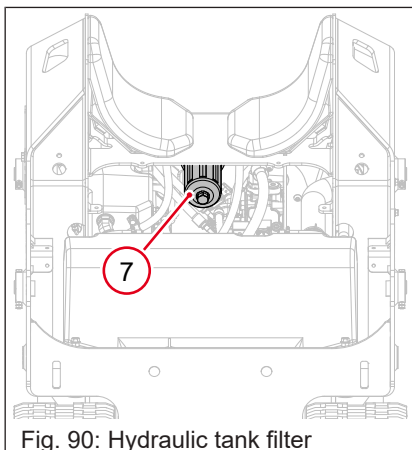

3. Remove the hydraulic filter (7).
4. Clean the surface of the filter housing where the seal contacts the housing.
5. Put clean oil on the seal of the new hydraulic filter.
6. Install and hand-tighten the hydraulic filter.
7. Start the engine and operate the hydraulic controls.
8. Stop the engine and check for leaks.
9. Observe the hydraulic oil level through the sight glass and add fluid as necessary.
10. Install the rear access panel.

7.26 Maintaining the Battery



⚠ DANGER

Explosion hazard

Batteries can emit explosive hydrogen gas.

- ▶ Keep all sparks, flames, and other ignition sources away from the battery.
- ▶ Do not short circuit battery posts.
- ▶ If the electrolyte is frozen, slowly warm the battery before recharging.



⚠ WARNING

Health hazard

Battery fluid is poisonous and corrosive.

- ▶ In the event of ingestion or contact with skin or eyes, wash skin or eyes with water and seek medical attention immediately.

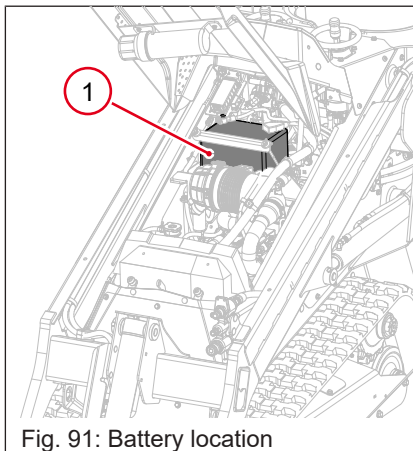

Fig. 91: Battery location

Precautions

To prevent serious damage to the electrical system:

- Do not disconnect the battery **(1)** while the machine is running.
- Do not reverse the positive (+) and negative (-) ends of the battery cable.
- Do not attempt to run the machine without a battery.
- Wear gloves and eye protection when working with batteries.
- When handling the battery, follow the battery manufacturer's safety instructions. Batteries contain caustic acids.
- A potentially combustible oxygen-hydrogen mixture forms in batteries during normal operation and especially when charging. Keep flames and sparks away from the battery.
- In the event that the machine has a discharged battery, either replace the battery with a fully charged battery or charge the battery using an appropriate battery charger.
- Dispose of discharged batteries in accordance with local environmental regulations.
- Agricultural or other chemicals, especially those with a high sulfur content, can adhere to the IC regulator. This will corrode the conductor and result in battery over-charging (boiling) and charging malfunctions. Consult YANMAR before using the equipment in such an environment or the warranty is voided.

When

- Every 50 hours—check the battery for damage; check cables and connections, and recharge

Maintaining

- Keep battery terminals clean and connections tight.
- When necessary, tighten the cables and grease the cable clamps with battery terminal grease or petroleum jelly.
- Maintain the battery at full charge to improve cold weather starting.

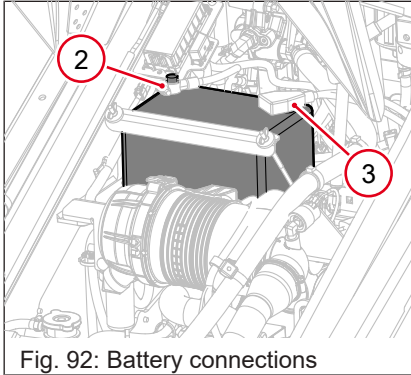

Fig. 92: Battery connections

Disconnecting

1. Stop the machine and shut down the engine.
2. Place all electrical switches in the OFF position.
3. Disconnect the negative battery cable (2) from the battery.
4. Disconnect the positive battery cable (3) from the battery.

Connecting

1. Connect the positive battery cable to the battery.
2. Connect the negative battery cable to the battery.

7.27 Engine—Jump-starting



⚠ WARNING

Personal injury hazard

Jump-starting a battery incorrectly can cause the battery to explode, resulting in severe personal injury or death.

- ▶ Keep all arcs, sparks, flames, and lighted tobacco away from the battery.
- ▶ Do not jump-start a frozen battery.
- ▶ Do not short circuit battery posts. Do not touch the frame or the negative terminal when working on the positive terminal.
- ▶ Wear safety glasses and gloves while using cables.



⚠ WARNING

Health hazard

Battery fluid is poisonous and corrosive.

- ▶ In the event of ingestion or contact with skin or eyes, wash skin or eyes with water and seek medical attention immediately.



⚠ CAUTION

Personal injury hazard

Electrical arcing can cause severe personal injury.

- ▶ Do not allow positive and negative cable ends to touch.

**NOTICE**

Observe the following precautions to prevent serious damage to the electrical system.

- ▶ Jump-starting a shorted or defective battery will cause the voltage regulator to supply higher than normal voltage. This can severely damage the digital electronics that control machine operation. If there is any doubt as to the battery's condition, a replacement battery should be used or an attempt should be made to charge the battery before starting the machine.
- ▶ Do not connect the negative clamp to a carburetor, fuel lines, or sheet metal body parts.
- ▶ Do not attempt to operate the machine without a battery.
- ▶ Dispose of waste batteries in accordance with local environmental regulations.

**NOTICE**

Extreme cold can cause the electrolytes inside the battery to freeze. Attempting to jump-start a frozen battery can cause it to rupture.

- ▶ When possible, do not allow the battery to sit in extreme cold.
- ▶ Slowly warm a frozen battery before trying to jump-start it.

**NOTICE**

Long cranking cycles can damage the starter.

- ▶ Do not crank the starter for more than 15 seconds.
- ▶ Wait 30 seconds before trying to crank the starter again so the battery can recover and the starter does not become overheated.

Overview

Jump-starting may occasionally be required if a battery is discharged. If jump-starting is needed, the following procedure is recommended to prevent starter damage, battery damage, and personal injuries.

Procedure

There are two procedures listed below. The first is for jump-starting a machine using another machine. The second is for jump-starting a machine with a jump pack.

Jump-starting the battery with another machine

1. In very cold weather, check the condition of the electrolytes. If it seems slushy or frozen, do not try jump-starting until it thaws.
2. Ensure all controls are in neutral and that the key switch is off.



3. Use a machine with a battery of the same voltage as is used with your engine system.
4. Attach one of the positive cable clamps (red) to the positive (+) terminal of the discharged battery. Attach the other positive cable clamp to the positive terminal of the donor battery.
5. Attach one of the negative cable clamps (black) to the negative (-) terminal of the donor battery. Attach the other negative cable clamp to a solid chassis ground on your engine or unpainted portion of the machine frame away from the discharged battery.
6. Start the engine on the machine with the donor battery.
7. Wait a minimum of 2 minutes while the discharged battery charges.
8. Turn the ignition key and hold it until the engine starts.
9. Immediately after the engine starts, disconnect the negative cable clamp first from the discharged battery and then the negative cable clamp from the donor battery.
10. Disconnect the positive cable clamp from the donor battery and then the positive cable clamp from the discharged battery.

Jump-starting the battery with a jump pack

1. In very cold weather, check the condition of the electrolytes. If it seems slushy or frozen, do not try jump-starting until it thaws.
2. Ensure all controls are in neutral and that the key switch is off.
3. Use a jump pack rated to start the machine.
4. Attach the positive cable clamp (red) to the positive (+) terminal of the discharged battery.
5. Attach the negative cable clamp (black) to a solid chassis ground on the engine or unpainted portion of the machine frame away from the battery.
6. If required, turn the power switch to ON on the jump pack.
7. Wait a minimum of 2 minutes while the discharged battery charges.
8. Turn the ignition key switch and hold it until the engine starts.
9. Immediately after the engine starts, disconnect the negative cable clamp.
10. Disconnect the positive cable clamp.
11. When using light or high amperage draw accessories, idle the engine for a period of 20 minutes to bring the battery to charge state.

8 Troubleshooting

8.1 Engine and Engine Oil Warning Lights

Engine Warning	Engine Stop	Oil Pressure	Description
Yellow	Red	Red	
			—
On	On	On	All warning and indicator lights illuminate for a few seconds if the key is turned to Position 1. If the engine stop or oil pressure light does illuminate, stop machine operation immediately and contact a Wacker Neuson service center.
Off	Off	Off	No malfunction.
On	On	On	Low oil pressure (if the oil pressure indicator light illuminates during operation). Check the oil level and add oil if necessary. If the indicator light still indicates the malfunction, stop the engine and contact a Wacker Neuson service center.

8.2 Diagnostic Trouble Codes

SPN	FMI	Description
517006	26	Hydraulic Oil Temperature Sensor Out of Range
517000	26	Fuel Level Sensor Out of Range
519014	24	Park Brake Push Button Logic Error

DTC (J1939 Format)				Description	J1939 Lamp Status			
Remark	SPN (Hex)	SPN (DEC)	FMI		MIL	RSL	AWL	PL
	4BA	1210	4	Engine Fuel Rack Position Sensor : Shorted to low source			X	
			3	Engine Fuel Rack Position Sensor : Shorted to high source		X (Engine drive)	X (E-ECU start)	
	5B	91	4	Accelerator Pedal Position Sensor "A" : Shorted to low source			X	
			3	Accelerator Pedal Position Sensor "A" : Shorted to high source			X	
			2	Accelerator Pedal Position Sensor "A" : Intermittent fault				
			1	Accelerator Pedal Position Sensor "A" : Below normal operational range (SAE J1843)			X	
			0	Accelerator Pedal Position Sensor "A" : Above normal operational range (SAE J1843)			X	
			15	Accelerator Pedal Position Sensor "A" : Not available (SAE J1843)			X	

DTC (J1939 Format)				Description	J1939 Lamp Status			
Remark	SPN (Hex)	SPN (DEC)	FMI		MIL	RSL	AWL	PL
	1D	29	4	Accelerator Pedal Position Sensor "B" : Shorted to low source			X	
			3	Accelerator Pedal Position Sensor "B" : Shorted to high source			X	
			2	Accelerator Pedal Position Sensor "B" : Intermittent fault				
			1	Accelerator Pedal Position Sensor "B" : Below normal operational range (SAE J1843)			X	
			0	Accelerator Pedal Position Sensor "B" : Above normal operational range (SAE J1843)			X	
			8	Accelerator Pedal Position Sensor "B" : Communication fault			X	
			15	Accelerator Pedal Position Sensor "B" : Not available (SAE J1843)			X	
	6C	108	4	Barometric Pressure Sensor : Shorted to low source	X			
			3	Barometric Pressure Sensor : Shorted to high source	X			
			2	Barometric Pressure Sensor : Intermittent fault				
	470	1136	4	E-ECU Internal Temperature Sensor: Shorted to low source			X	
			3	E-ECU Internal Temperature Sensor : Shorted to high source			X	
			2	E-ECU Internal Temperature Sensor : Intermittent fault				
			0	E-ECU Internal Temperature : Too High				X
	6E	110	4	Engine Coolant Temperature Sensor: Shorted to low source			X	
			3	Engine Coolant Temperature Sensor: Shorted to high source			X	
			2	Engine Coolant Temperature Sensor : Intermittent fault				
			0	Engine Coolant Temperature : Too High				X
	437	1079	4	Sensor 5V : Shorted to low source			X	
			3	Sensor 5V : Shorted to high source			X	
			2	Sensor 5V : Intermittent fault				
	9E	158	1	System Voltage : Too Low				X
			0	System Voltage : Too High				X
	436	1078	4	Engine Fuel Injection Pump Speed Sensor : Shorted to low source		X (Both)	X (Either)	

DTC (J1939 Format)				Description	J1939 Lamp Status			
Remark	SPN (Hex)	SPN (DEC)	FMI		MIL	RSL	AWL	PL
1)	7F8A2	522402	4	Auxiliary Speed Sensor : Shorted to low source				
1)	7F801	522241	4	Engine Fuel Rack Actuator Relay : Circuit fault A		X		
			3	Engine Fuel Rack Actuator Relay : Circuit fault B		X		
			7	(Reserved)				
			2	Engine Fuel Rack Actuator Relay: Intermittent fault				
1)	7F803	522243	4	Air Heater Relay : Circuit fault A	X			
			3	Air Heater Relay : Circuit fault B	X			
			2	Air Heater Relay : Intermittent fault				
1)	7F802	522242	4	Cold Start Device : Circuit fault A	X			
			3	Cold Start Device : Circuit fault B	X			
			2	Cold Start Device : Intermittent fault				
	64	100	4	Oil Pressure Switch : Shorted to low source			X	
			1	Oil Pressure : Too Low				X
	A7	167	4	Battery Charge Switch : Shorted to low source			X	
			1	Charge warning				X
1)	7F84A	522314	0	Engine Coolant Temperature : Abnormal temperature				X
	BE	190	0	Engine speed : Over speed Condition		X		
	27E	638	4	Engine Fuel Rack Actuator : Shorted to low source		X		
			3	Engine Fuel Rack Actuator : Shorted to high source		X		
			7	Engine Fuel Rack Actuator : Mechanical Malfunction		X		
			2	Engine : Malfunction		X		
	27F	639	12	High Speed CAN Communication : Communication fault			X	
	276	630	2	E-ECU internal fault : EEPROM Check Sum Error (Data Set 2)		X		
			12	E-ECU internal fault : EEPROM ReadWrite fault			X	
	274	628	12	E-ECU internal fault : FlashROM Check Sum Error (Main Software)		X		
			2	E-ECU internal fault : FlashROM Check Sum Error (Data Set 1)		X		
			2	E-ECU internal fault : FlashROM Check Sum Error (Data Set 2)		X		

DTC (J1939 Format)				Description	J1939 Lamp Status			
Remark	SPN (Hex)	SPN (DEC)	FMI		MIL	RSL	AWL	PL
	5CD	1485	4	E-ECU Main Relay : Shorted to low source			X	
1)	7F9E7	522727	12	E-ECU internal fault : Sub-CPU Error A			X	
			12	E-ECU internal fault : Sub-CPU Error B			X	
			12	E-ECU internal fault : Sub-CPU Error C			X	
1)	7F9E8	522728	12	E-ECU internal fault : Engine Map Data Version Error		X		
1)	7F9EA	522730	12	Immobilizer : CAN Communication fault			X	
			8	Immobilizer : Pulse Communication fault			X	
	4B2	1202	2	Immobilizer: System fault			X	

1) Yanmar original DTC

9 Shutdown

9.1 Long-Term Storage



NOTICE

Allowing the battery to freeze or completely discharge is likely to cause permanent damage.

- ▶ Periodically charge the battery while the machine is not in use.
- ▶ In cold climates, store and charge the battery indoors or in a warm location.

Introduction

Extended storage of equipment requires preventive maintenance. Performing these steps helps to preserve machine components and ensures the machine will be ready for future use. While not all of these steps necessarily apply to this machine, the basic procedures remain the same.

When

Prepare your machine for extended storage if it will not be operated for 30 days or more.

Preparing for storage

- Complete any needed repairs.
- Replenish or change oils (engine, hydraulic) per the intervals specified in the periodic maintenance schedule table.
- Grease all fittings.
- Inspect engine coolant. Replace coolant if it appears cloudy, is more than two seasons old, or does not meet the average lowest temperature for your area.
- Consult the engine owner's manual for instructions on preparing the engine for storage.

Stabilizing the fuel

After completing the procedures listed above, fill the fuel tank completely and add a high-quality stabilizer to the fuel.

- Choose a stabilizer that includes cleaning agents and additives designed to coat/protect the cylinder walls.
- Ensure the stabilizer you use is compatible with the fuel in your area, fuel type, grade, and temperature range.
- Use a stabilizer with a biocide to restrict or prevent bacteria and fungus growth.
- Add the correct amount of stabilizer per the manufacturer's recommendations.

Storing the machine

- Wash the machine and allow it to dry.
- Move the machine to a clean, dry, secure storage location. Block or chock the to prevent machine movement.
- Use touch-up paint as needed to protect exposed metal against rust.
- If the machine has a battery, either remove or disconnect it.
- Cover the machine. To protect and other exposed rubber items from the weather, either cover them or use a readily available protectant.

9.2 Machine Disposal and Decommissioning

This machine must be properly decommissioned at the end of its service life. Responsible disposal of recyclable components, such as plastic and metal, ensures these materials can be reused, conserving landfill space and valuable natural resources.

Responsible disposal also prevents toxic chemicals and materials from harming the environment. The operating fluids in this machine, including fuel, engine oil, and grease, may be considered hazardous waste in many areas. Before decommissioning this machine, read and follow local safety and environmental regulations pertaining to the disposal of construction equipment.

Preparation

- Move the machine to a protected location where it will not pose any safety hazards and cannot be accessed by unauthorized individuals.
- Ensure the machine cannot be operated from the time of final shutdown to disposal.
- Drain all fluids, including fuel, engine oil, and coolant.
- Seal any fluid leaks.

Disposal

- Disassemble the machine and separate all parts by material type.
- Dispose of recyclable parts as specified by local regulations.
- Dispose of all non-hazardous components that cannot be recycled.
- Dispose of waste fuel, oil, and grease in accordance with local environmental protection regulations.

10 Technical Data

10.1 Engine

Item	Units	SM100
Engine make	—	Yanmar
Engine model	—	3TNV80FT
Emissions	—	Tier IV final
Number of cylinders	—	3
Displacement	L	1.266
Nominal bore and stroke	mm (in.)	Bore—80 (3.1) stroke—84 (3.3)
Output	kw (hp)	18.4 (24.7)
Gross torque	Nm (ft. lbs.)	85 (62.7)
Maximum engine speed without load	rpm	2,600
Idling speed	rpm	1,200
Fuel injection system	—	Mechanical indirect injection

10.2 Machine Speeds

Item	Units	SM100
Forward travel speed	km/h (mph)	8.4 (5.2)
Reverse travel speed	km/h (mph)	8.4 (5.2)

10.3 Fluids

Item	Units	SM100
Engine		
Oil capacity	L (qt)	3.4 (3.6)
Coolant type	—	ATSM D6210, D4985
Coolant capacity	L (qt)	6.38 (6.75)
Hydraulics		
Hydraulic oil type	—	10W-30
Hydraulic oil capacity	L (qt)	13.2 (14qt)
Aux hydraulic flow - standard	L/min (gal/min)	49.3 (13.0)
Aux hydraulic relief pressure	bar (psi)	210 (3,045psi)
Fuel		
Tank capacity	L (gal)	64.0 (14.1)

10.4 Electrical System

Item	Units	SM100
Alternator	A	55A
Starter	kW	1.1 kW
Battery	CCA	12V 650 CCA

10.5 Hydraulic System

Item	Units	SM100
Pump type	—	Gear
Auxiliary flow rate	l/min (gpm)	49.3 (13.0)
Auxiliary relief pressure	bar (psi)	210 (3,045)
Lift and tilt port relief pressure	bar (psi)	230 (3,356)
Charge/pilot pump flow rate	l/min (gpm)	14.5 (3.83)
Charge/pilot pressure	bar (psi)	20 (290)
Hydraulic function time:	seconds	
Raise lift arms		3.08
Lower lift arms		2.03
Bucket dump		1.59
Bucket rollback		1.31

10.6 Drive System

Item	Units	SM100
Drive type	—	Hydrostatic
Relief pressure	bar (psi)	300 (4,351)

10.7 Controls

Item	SM100
Type	Hydraulic pilot
Pattern	ISO
Workgroup type	ISO manual lever
Engine speed	Electronic dial
Service brake	Hydrostatic trans
Parking brake	Spring applied pressure release (SAPR)
Parking brake control	Automatic/switchable

10.8 Forces

Item	Units	SM100
Rated operating capacity (ROC) at 50% of tip load	kg (lb)	647 (1,428)
Rated operating capacity (ROC) at 35% of tip load	kg (lb)	453 (1,000)
Tip load	kg (lb)	1,295 (2,857)
Breakout force—tilt	kN (lb)	1,410 (3,110)
Breakout force—lift	kN (lb)	1,410 (3,110)
Max tractive effort	N (lbf)	2,2850 (5,137)

10.9 Weights and Ground Pressure

Item	Units	SM100
Operating weight	kg (lb)	1,497 (3,300)
Ground pressure	kPA (psi)	28.8 (4.1)

Note: Add the weight of all subsequently installed equipment to the machine weight, which must be read off the label. Weight can vary by +/- 2%.

10.10 Tightening Torques

Property Class	8.8	10.9	12.9	8.8	10.9
Screw Dimensions	Screws According to DIN 912, DIN 933, etc.			Screws According to DIN 7984	
	Nm (ft. lbs.)	Nm (ft. lbs.)	Nm (ft. lbs.)	Nm (ft. lbs.)	Nm (ft. lbs.)
M5	5.5 (4)	8 (6)	10 (7)	5 (4)	7 (5)
M6	10 (7)	14 (10)	17 (13)	8.5 (6)	12 (9)
M8	25 (18)	35 (26)	42 (31)	20 (15)	30 (22)
M10	45 (33)	65 (48)	80 (59)	40 (30)	59 (44)
M12	87 (64)	110 (81)	147 (108)	69 (51)	100 (74)
M14	135 (100)	180 (133)	230 (170)	110 (81)	160 (118)
M16	210 (155)	275 (203)	350 (258)	170 (125)	250 (184)
M18	280 (207)	410 (302)	480 (354)	245 (181)	345 (254)
M20	410 (302)	570 (420)	690 (509)	340 (251)	490 (361)
M22	550 (406)	780 (575)	930 (686)	460 (339)	660 (487)
M24	710 (524)	1,000 (738)	1,190 (878)	590 (435)	840 (620)
M27	1,040 (767)	1,480 (1,092)	1,770 (1,305)	870 (642)	1,250 (922)
M30	1,420 (1,047)	2,010 (1,482)	2,400 (1,770)	1,200 (885)	1,700 (1,254)
Fine-pitched Thread					
M8 x 1.0	25 (18)	37 (28)	43 (32)	22 (16)	32 (24)
M10 x 1.0	50 (37)	75 (55)	88 (65)	43 (32)	65 (48)
M10 x 1.25	49 (36)	71 (52)	83 (61)	42 (31)	62 (46)
M12 x 1.25	87 (64)	130 (96)	150 (111)	75 (55)	110 (81)
M12 x 1.5	83 (61)	125 (92)	145 (107)	72 (53)	105 (77)
M14 x 1.5	135 (100)	200 (148)	235 (173)	120 (89)	175 (129)
M16 x 1.5	210 (155)	310 (229)	360 (266)	180 (133)	265 (195)
M18 x 1.5	315 (232)	450 (332)	530 (391)	270 (199)	385 (284)
M20 x 1.5	440 (325)	630 (465)	730 (538)	375 (277)	530 (391)
M22 x 1.5	590 (435)	840 (620)	980 (723)	500 (369)	710 (524)
M24 x 2.0	740 (546)	1,070 (789)	1,250 (922)	630 (465)	900 (664)
M27 x 2.0	1,100 (811)	1,550 (1,143)	1,800 (1,328)	920 (679)	1,300 (959)
M30 x 2.0	1,500 (1,106)	2,150 (1,586)	2,500 (1,844)	1,300 (959)	1,850 (1,364)

YANMAR engine standard torque chart

The tightening torque in the following table should be applied only to the bolts with a "7" head (JIS strength classification: 7T). Torque values shown are for clean, non-lubricated fasteners unless otherwise specified.

- For 4T bolts and locknuts, apply 60% of the torque listed in the table.
- If aluminum alloy is contained in the parts to be tightened, apply 80 % of the torque listed in the table.

Thread Size x Pitch	mm	M6 x 1.0	M8 x 1.25	M10 x 1.5	M12 x 1.75	M14 x 1.5	M16 x 1.5
Tightening torque	in. lbs.	96.0 ± 9.0	—	—	—	—	—
	ft. lbs.	—	19.0±2.0	36.0±4.0	65.0±7.0	101.0±7.0	167.0±7.0
	Nm	10.8 ± 1.0	25.5 ± 2.9	49.0 ± 4.9	88.3 ± 9.8	137.0 ± 9.8	226.0 ± 9.8
	kgf m	1.1 ± 0.1	2.6 ± 0.3	5.0 ± 0.5	9.0 ± 1.0	14.0 ± 1.5	23.0 ± 2.0

10.11 Dimensions

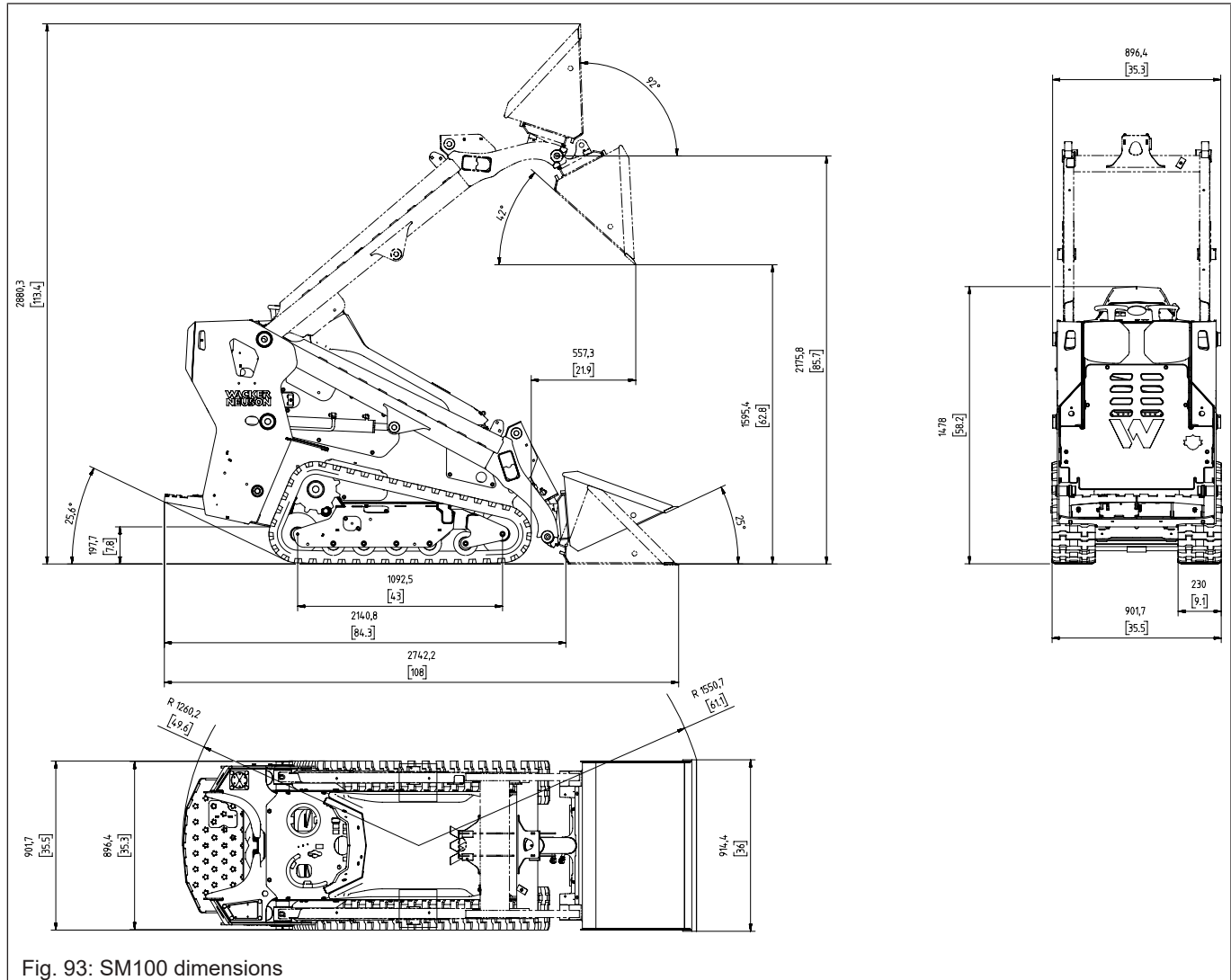

11 Emission Control Systems Information and Warranty— Diesel

The Emission Control Warranty and associated information is valid only for the U.S.A., its territories, and Canada.

11.1 Emission Control System Background Information

Introduction

Wacker Neuson engines/equipment must conform with applicable Environmental Protection Agency (EPA) and California Air Resource Board (CARB) emissions regulations. These regulations require that manufacturers warrant the emission control systems for defects in materials and workmanship.

Furthermore, EPA and CARB regulations require all manufacturers to furnish written instructions describing how to operate and maintain the engines/equipment including the emission control systems. This information is provided with all Wacker Neuson engines/equipment at the time of purchase.

Exhaust emissions

The combustion process produces carbon monoxide, oxides of nitrogen, and hydrocarbons. Control of hydrocarbons and oxides of nitrogen is very important because, under certain conditions, they react to form photochemical smog when subjected to sunlight. Carbon monoxide does not react in the same way, but it is toxic.

Problems that may affect emissions

If any of the following symptoms arise, have the engine/equipment inspected and repaired by a Wacker Neuson dealer/service center.

- Hard starting or stalling after starting
- Rough idling
- Misfiring or backfiring under load
- Afterburning (backfiring)
- Presence of black exhaust smoke during operation
- High fuel consumption

Tampering and altering

Tampering with or altering the emission control system may increase emissions beyond the legal limit. If evidence of tampering is found, Wacker Neuson may deny a warranty claim. Among those acts that constitute tampering are:

- Removing or altering of any part of the air intake, fuel, or exhaust systems.
- Altering or defeating the speed-adjusting mechanism causing the engine to operate outside its design parameters.

11.2 Limited Defect Warranty for Exhaust Emission Control System

See the supplied engine owner's manual for the applicable emission warranty statement.

11.3 Limited Defect Warranty for Wacker Neuson Emission Control Systems

The Emission Control Warranty is valid only for the U.S.A., its territories, and Canada.

Wacker Neuson America Corporation, N92 W15000 Anthony Avenue, Menomonee Falls, WI 53051, (hereinafter "Wacker Neuson") warrants to the initial retail purchaser and each subsequent owner, that this engine/equipment, including all parts of its emission control system, have been designed, built, and equipped to conform at the time of initial sale to all applicable evaporative emission regulations of the U.S. Environmental Protection Agency (EPA), and that the engine/equipment is free of defects in materials and workmanship which would cause this engine/equipment to fail to conform to EPA regulations during its warranty period.

Wacker Neuson is also liable for damages to other engine/equipment components caused by a failure of any warranted parts during the warranty period.

What is covered

Wacker Neuson recommends the use of genuine Wacker Neuson parts, or the equivalent, whenever maintenance is performed. The use of replacement parts not equivalent to the original parts may impair the effectiveness of the engine/equipment emission controls systems. If such a replacement part is used in the repair or maintenance of the engine/equipment, assure yourself that such part is warranted by its manufacturer to be equivalent to the parts offered by Wacker Neuson in performance and durability. Furthermore, if such a replacement part is used in the repair or maintenance of the engine/equipment, and an authorized Wacker Neuson dealer/service center determines it is defective or causes a failure of a warranted part, the claim for repair of the engine/equipment may be denied. If the part in question is not related to the reason the engine/equipment requires repair, the claim will not be denied.

For the components listed in the following table, an authorized Wacker Neuson dealer/service center will, at no cost to you, make the necessary diagnosis, repair, or replacement necessary to ensure the engine/equipment complies with the applicable EPA regulations. All defective parts replaced under this warranty become property of Wacker Neuson.

System Covered	Components
Exhaust system	Flex section of the exhaust pipe
	Tail pipe

What is not covered

- Failures other than those resulting from defects in material or workmanship.
- Any systems or parts which are affected or damaged by owner abuse, tampering, neglect, improper maintenance, misuse, improper fueling, improper storage, accident and/or collision; the incorporation of, or any use of, add-on or modified parts, or unsuitable attachments, or the alteration of any part.
- Replacement of expendable maintenance items made in connection with required maintenance services after the item's first scheduled replacement as listed in the maintenance section of the engine/equipment operator's manual, such as spark plugs and filters.
- Incidental or consequential damages such as loss of time or the use of the engine/equipment, or any commercial loss due to the failure of the engine/equipment.
- Diagnosis and inspection charges that do not result in warranty-eligible service being performed.
- Any non-authorized replacement part, or malfunction of authorized parts due to use of non-authorized parts.

Owner's warranty responsibility

The engine/equipment owner, is responsible for the performance of the required maintenance listed in the Wacker Neuson engine/equipment operator's manual. Wacker Neuson recommends that all receipts covering maintenance on the engine/equipment be retained, but Wacker Neuson cannot deny warranty coverage solely for the lack of receipts or for the failure to ensure the performance of all scheduled maintenance.

Normal maintenance, replacement, or repair of emission control devices and systems may be performed by any repair establishment or individual; however, warranty repairs must be performed by an authorized Wacker Neuson dealer/service center.

The engine/equipment must be presented to an authorized Wacker Neuson dealer/service center as soon as a problem exists. Contact Wacker Neuson Product Support Department (1-800-770-0957) or visit wackerneuson.com to find a dealer/service center in your area, or to answer questions regarding warranty rights and responsibilities.

How to make a claim

In the event that any emission-related part is found to be defective during the warranty period, you shall notify Wacker Neuson Product Support Department (1-800-770-0957, or technical.support@wackerneuson.com, or wackerneuson.com), and you will be advised of the appropriate dealer/service center where warranty repair can be performed. All repairs qualifying under this limited warranty must be performed by an authorized Wacker Neuson dealer/service center.

You must take your Wacker Neuson engine/equipment along with proof of original purchase date, at your expense, to the authorized Wacker Neuson dealer/service center during their normal business hours.

For owners located more than 100 miles from an authorized dealer/service center (excluding the states with high-altitude areas as identified in 40 CFR Part 1068, Appendix III), Wacker Neuson will pay for preapproved shipping costs to and from an authorized Wacker Neuson dealer/service center.

Claims for repair or adjustment found to be caused solely by defects in material or workmanship will not be denied because the engine/equipment was not properly maintained and used.

The warranty repairs should be completed in a reasonable amount of time, not to exceed 30 days.

Limited defect warranty period for Wacker Neuson emission control systems

The warranty period for this engine/equipment begins on the date of sale to the initial purchaser and continues for a period of 4 years or 4,000 hours of operation (whichever comes first). For the warranty terms for your specific engine/equipment, visit wackerneuson.com.

Any implied warranties are limited to the duration of this written warranty.

11.4 Yanmar Limited Warranty

What is covered by this warranty?

YANMAR warrants to the original retail purchaser that a new YANMAR TNV series industrial engine will be free from defects in material and/or workmanship for the duration of the warranty period.

Note: YANMAR engines may be equipped with external components including, but not limited to: wiring harnesses, electrical devices, control panels, radiators, air filters, fuel filters, and/or exhaust systems that are supplied and/or installed by manufacturers other than YANMAR. For warranty information on such external components, please contact the machine or component manufacturer directly or see your authorized YANMAR dealer or distributor.

This warranty is provided in lieu of all other warranties, express or implied. YANMAR specifically disclaims any implied warranties of merchantability or fitness for a particular purpose, except where such disclaimer is prohibited by law. If such disclaimer is prohibited by law, then implied warranties shall be limited in duration to the life of the express warranty.

How long is the warranty period?

The YANMAR standard limited warranty period runs for a period of **twenty-four (24) months or two-thousand (2000) engine operation hours**, whichever occurs first. An extended limited warranty of thirty-six (36) months or three thousand (3000) engine operating hours, whichever occurs first, is provided for these specific parts only: the cylinder block, cylinder head, crankshaft forging, connecting rods, flywheel, flywheel housing, camshaft, timing gear, and gear case. The warranty period for both the standard limited warranty and the extended limited warranty (by duration or operation hours) begins on the date of delivery to the original retail purchaser and is valid only until the applicable warranted duration has passed or the operation hours are exceeded, whichever comes first.

What the engine owner must do

If you believe your YANMAR engine has experienced a failure due to a defect in material and/or workmanship, you must contact an authorized YANMAR industrial engine dealer or distributor within thirty (30) days of discovering the failure. You must provide proof of ownership of the engine, proof of the date of the engine purchase and delivery, and documentation of the engine operation hours. Acceptable forms of proof of delivery date include, but are not limited to: the original warranty registration or sales receipts or other documents maintained in the ordinary course of business by YANMAR dealers and/or distributors, indicating the date of delivery of the YANMAR product to the original retail purchaser. This information is necessary to establish whether the YANMAR product is still within the warranty period. Thus, YANMAR strongly recommends you register your engine as soon as possible after purchase in order to facilitate any future warranty matters.

You are responsible for the transportation of the engine to and from the repair location as designated by YANMAR.

To locate an authorized YANMAR industrial engine dealer or distributor

You can locate your nearest authorized YANMAR industrial engine dealer or distributor by visiting the YANMAR website at:

<https://www.yanmar.com/global/> (The English language page will be displayed.)

- "Click" on "Dealer Locator" in the website heading to view the "Dealer Locator" menu.
- Choose the Country from the pull down menu.
- Choose the Product Category from the pull down menu.
- "Click" on "Search" to browse YANMAR dealer or distributor.

You may also contact YANMAR by clicking on "Contact" icon in the website heading and typing in your question or comment.

What YANMAR will do

YANMAR warrants to the original retail purchaser of a new YANMAR engine that YANMAR will make such repairs and/or replacements at YANMAR's option, of any part(s) of the YANMAR product covered by this warranty found to be defective in material and/or workmanship. Such repairs and/or replacements will be made at a location designated by YANMAR at no cost to the purchaser for parts or labor.

What is not covered by this warranty?

This warranty does not cover parts affected by or damaged by any reason other than defective materials or workmanship, including, but not limited to, accident, misuse, abuse, "Acts of God," neglect, improper installation, improper maintenance, improper storage, the use of unsuitable attachments or parts, the use of contaminated fuels, the use of fuels, oils, lubricants, or fluids other than those recommended in your YANMAR Operation Manual, unauthorized alterations or modifications, ordinary wear and tear, and rust or

corrosion. This warranty does not cover the cost of parts and/or labor required to perform normal/scheduled maintenance on your YANMAR engine. This warranty does not cover consumable parts such as, but not limited to, filters, belts, hoses, fuel injector nozzles, lubricants and cleaning fluids. This warranty does not cover the cost of shipping the product to or from the warranty repair facility.

Warranty limitations

The foregoing is YANMAR's only obligation to you and your exclusive remedy for breach of warranty. Failure to follow the requirements for submitting a claim under this warranty may result in a waiver of all claims for damages and other relief. **In no event shall YANMAR or any authorized industrial engine dealer or distributor be liable for incidental, special or consequential damages.** Such consequential damages may include, but not be limited to, loss of revenue, loan payments, cost of rental of substitute equipment, insurance coverage, storage, lodging, transportation, fuel, mileage, and telephone costs. The limitations in this warranty apply regardless of whether your claims are based on breach of contract, tort (including negligence and strict liability) or any other theory. Any action arising hereunder must be brought within one (1) year after the cause of action accrues or it shall be barred. Some states and countries do not allow certain limitations on warranties or for breach of warranties. **This warranty gives you specific legal rights, and you may also have other rights which vary from state to state and country to country.** Limitations set forth in this paragraph shall not apply to the extent that they are prohibited by law.

Warranty modifications

Except as modified in writing and signed by the parties, this warranty is and shall remain the complete and exclusive agreement between the parties with respect to warranties, superseding all prior agreements, written and oral, and all other communications between the parties relating to warranties. **No person or entity is authorized to give any other warranty or to assume any other obligation on behalf of YANMAR, either orally or in writing.**

Questions

If you have any questions or concerns regarding this warranty, please call or write to the nearest authorized YANMAR industrial engine dealer or distributor or other authorized facility.

11.5 Yanmar Power Technology Co., Ltd. Emission Control System Warranty—USA Only

Your warranty rights and obligations

The California Air Resources Board (CARB), the United State Environmental Protection Agency (EPA) and YANMAR POWER TECHNOLOGY CO., LTD. hereafter referred to as YANMAR, are pleased to explain the **emission control system warranty** on your 2020, 2021, or 2022 model year industrial compression-ignition engine. California-certified, new off-road compression-ignition engines must be designed, built and equipped to meet the State's

stringent anti-smog standards. In the remaining forty nine (49) states, new non-road compression-ignition engines must be designed, built and equipped to meet the United States EPA emissions standards. YANMAR must warrant the emission control system on your engine for the periods of time listed below provided there has been no abuse, neglect or improper maintenance of your engine.

Your emission control system may include parts such as the fuel injection system, the air induction system, the electronic control system, and the EGR (Exhaust Gas Recirculation) system. Also included may be hoses, belts, connectors and other emission-related assemblies.

Where a warrantable condition exists, YANMAR will repair your off-road compression-ignition engine at no charge to you including diagnosis, parts and labor.

Manufacturer's warranty period

2020, 2021, or 2022 model year off-road compression-ignition engines are warranted for the periods listed below. If any emission-related part on your engine is found to be defective during the applicable warranty period, the part will be repaired or replaced by YANMAR.

If your engine is certified as	And its maximum power is	And its rated speed is	Then its warranty period is
Variable speed or constant speed	kW < 19	Any speed	2,000 hours or two (2) years whichever comes first. In the absence of a device to measure the hours of use, the engine has a warranty period of two (2) years.
Constant speed	19 > kW < 37	3,000 rpm or higher	2,000 hours or two (2) years whichever comes first. In the absence of a device to measure the hours of use, the engine has a warranty period of two (2) years.
Constant speed	19 > kW < 37	Less than 3,000 rpm	3,000 hours or five (5) years whichever comes first. In the absence of a device to measure the hours of use, the engine has a warranty period of five (5) years.
Variable speed	19 > kW < 37	Any speed	3,000 hours or five (5) years whichever comes first. In the absence of a device to measure the hours of use, the engine has a warranty period of five (5) years.
Variable speed or constant speed	kW~37	Any speed	3,000 hours or five (5) years whichever comes first. In the absence of a device to measure the hours of use, the engine has a warranty period of five (5) years.

Warranty coverage

This warranty is transferable to each subsequent purchaser for the duration of the warranty period. YANMAR recommends that repair or replacement of any warranted part will be performed at an authorized YANMAR dealer.

Warranted parts not scheduled for replacement as required maintenance in the owner's manual shall be warranted for the warranty period. Warranted parts scheduled for replacement as required maintenance in the owner's manual are warranted for the period of time prior to the first scheduled replacement. Any warranted parts scheduled for replacement as required maintenance that are repaired or replaced under warranty shall be warranted for the remaining period of time prior to the first scheduled replacement. Any part not scheduled for replacement that is repaired or replaced under warranty shall be warranted for the remaining warranty period.

During the warranty period, YANMAR is liable for damages to other engine components caused by the failure of any warranted part during the warranty period.

Any replacement part which is functionally identical to the original equipment part in all respects may be used in the maintenance or repair of your engine, and shall not reduce YANMAR's warranty obligations. Add-on or modified parts that are not exempted may not be used. The use of any non-exempted add-on or modified parts shall be grounds for disallowing a warranty.

Warranted parts

This warranty covers engine components that are a part of the emission control system of the engine as delivered by YANMAR to the original retail purchaser. Such components may include the following:

- Fuel injection system (including Altitude compensation system)
- Cold start enrichment system
- Intake manifold and Air intake throttle valve
- Turbocharger systems
- Exhaust manifold and exhaust throttle valve
- Positive crankcase ventilation system
- Charge Air Cooling systems
- Exhaust Gas Recirculation (EGR) systems
- Exhaust gas after treatment (diesel particulate filter system, urea SCR system)
- Electronic Control units, sensors, solenoids and wiring harnesses used in above systems
- Hoses, belts, connectors and assemblies used in above systems
- Emission Control Information Labels

Since emissions related parts may vary slightly between models, certain models may not contain all of these parts and other models may contain the functional equivalents.

Exclusions

Failures other than those arising from defects in material or workmanship are not covered by this warranty. The warranty does not extend to the following: malfunctions caused by abuse, misuse, improper adjustment, modification, alteration, tampering, disconnection, improper or inadequate maintenance, or use of non-recommended fuels and lubricating oils; accident-caused damage and replacement of expendable items made in connection with scheduled maintenance. YANMAR disclaims any responsibility for incidental or consequential such as loss of time, inconvenience, loss of use of equipment/engine or commercial loss.

Owner's warranty responsibilities

As the off-road compression-ignition engine owner, you are responsible for the performance of the required maintenance listed in your owner's manual. YANMAR recommends that you retain all documentation, including receipts, covering maintenance on your off-road compression-ignition engine, but YANMAR cannot deny warranty solely for the lack of receipts, or for your failure to ensure the performance of all scheduled maintenance.

YANMAR may deny your warranty coverage if your off-road compression-ignition engine or a part has failed due to abuse, neglect, improper maintenance or unapproved modifications.

Your engine is designed to operate on diesel fuel only. Use of any other fuel may result in your engine no longer operating in compliance with CARB and EPA emissions requirements.

You are responsible for initiating the warranty process. You are responsible for presenting your engine to an authorized YANMAR dealer or distributor as soon as a problem exists. The warranty repairs should be completed by the dealer as expeditiously as possible. If you have any questions regarding your warranty rights and responsibilities, or would like information on the nearest YANMAR dealer or authorized service center, you should contact YANMAR America Corporation.

Website: <https://www.yanmar.com>

E-mail: CS_support@yanmar.com

Toll free telephone number: 1-800-872-2867, 1-855-416-7091

What the emergency stationary type engine owner must do

The engines for emergency stationary type generators certified by Federal Law (40 CFR Part60) are limited to emergency use only, and the operation for maintenance checks and verification test for functions is required. The total operating hours for maintenance and verification test for functions should not exceed 100 hours per year. However, there is no limitation on the operating hours for emergency use. Keep a log of the number of hours the engine is operated for both emergency use and non-emergency use. Also, note the reason for the operation.



SAFETY MANUAL

FOR OPERATING AND MAINTENANCE PERSONNEL



Contents

Acknowledgment	2
Foreword	3
Safety Alerts	4
A Word to the User/Operator	5
The Compact Tool Carrier	6
One-Call First	7
Follow a Safety Program	8
Prepare for Safe Operation	13
Start Safely	19
Operate Safely	22
Shut Down Safely	32
Load and Unload Your Machine	33
Perform Maintenance Safely	34
Final Word to the User	47

Acknowledgment

We wish to acknowledge the contributions of the members of AEM's Compact Loader/Compact Excavator Council to the preparation of this Safety Manual.

NOTICE OF COPYRIGHT PROTECTION

Copyright, 2008, by the Association of Equipment Manufacturers. All rights reserved. This work may not be reproduced or disseminated in whole or in part by any means without the prior written permission of the Association of Equipment Manufacturers.

Foreword

This safety manual is intended to point out some of the basic safety situations that may be encountered during the normal operation and maintenance of your machine and to suggest possible ways of dealing with these conditions. This manual is **NOT** a substitute for the compact tool carrier manufacturer's operator's manual(s).

Additional precautions may be necessary, or some instructions may not apply, depending on equipment, attachments and conditions at the worksite or in the service area. The manufacturer has no direct control over equipment application, operation, inspection or maintenance. Therefore, it is **YOUR** responsibility to use good safety practices in these areas.

The information provided in this manual supplements the specific information about your machine that is contained in the manufacturer's manual(s). Other information that may affect the safe operation of your machine may be contained on safety signs or in insurance requirements, employer's safety and training programs, safety codes, local, state/provincial and federal laws, rules and regulations.



Read and Understand Manuals Before Operating



IMPORTANT! Before you operate the compact tool carrier, make sure you have the manufacturer's manual(s) for this machine and all attachments. If the manufacturer's manuals are missing, obtain replacement manuals from your employer, equipment dealer or directly from the manufacturer. Keep this safety manual and the manufacturer's manuals with the machine at all times. Read and understand all manuals.

Safety videos are available from some manufacturers. Operators are encouraged to periodically review the safety video.

Safety Alerts

Symbol

This Safety Alert Symbol means: **"ATTENTION! STAY ALERT! YOUR SAFETY IS INVOLVED!"**

The Safety Alert Symbol identifies important safety messages on equipment, safety signs, in manuals or elsewhere. When you see this symbol, be alert to the possibility of death or personal injury. Follow instructions in the safety message.



Three Reasons Safety is Important to You:

1. Accidents disable and kill.
2. Accidents cost.
3. Accidents can be avoided.

Signal Words

Signal words are distinctive words that will typically be found on safety signs on the compact tool carrier and other worksite equipment. These words may also be found in this manual and the manufacturer's manuals. These words are intended to alert the operator to a hazard and the degree of severity of the hazard.



DANGER indicates a hazardous situation which, if not avoided, will result in death or serious injury.



WARNING indicates a hazardous situation which, if not avoided, could result in death or serious injury.



CAUTION indicates a hazardous situation which, if not avoided, could result in minor or moderate injury.



NOTICE indicates a property damage message.

A Word to the User/Operator

It is **YOUR** responsibility to read and understand the safety manual and the manufacturer's manuals before operating this machine. This safety manual takes you step by step through your working day.

Graphics have been provided to help you understand the text.



Remember that **YOU** are the key to safety. Good safety practices not only protect you but also protect the people around you. Study this manual and the manufacturer's manuals for your specific machine. Make them a working part of your safety program. Keep in mind that this safety manual is written only for compact tool carriers.

Contact the manufacturer of your equipment to answer any questions about safe operation that remain after studying the manufacturer's manual(s) and this safety manual.

Practice all other usual and customary safe working precautions and above all:
REMEMBER — SAFETY IS UP TO YOU!
YOU CAN PREVENT SERIOUS INJURY OR DEATH CAUSED BY UNSAFE WORK PRACTICES!

5

The Compact Tool Carrier

This safety manual covers safe operating practices for compact tool carriers. Compact tool carriers can be equipped with either tracks or tires.

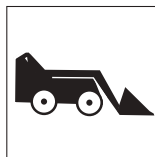

Wheeled Type

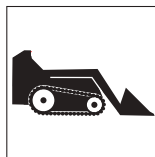

Track Type



IMPORTANT! This manual covers safe practices for compact tool carriers equipped with a bucket, pallet forks or simple attachments. If your compact tool carrier is equipped with complex attachments such as a snow blower or backhoe, read the manufacturer's operating and safety manuals for those attachments before using them.

The compact tool carrier is not intended to be used as an all-terrain vehicle.

6

One-Call First



Call Before You Dig
Dial 811 (USA only)



888-258-0808
(USA & Canada)

Call

Before starting any digging project, contact your local One-Call service by dialing 811 (USA only) to have underground utilities located. A One-Call referral number, **1-888-258-0808**, is also available for both USA and Canada.

One-Call will notify participating utility companies that you intend to dig. You must also call any utility companies which do not participate in the One-Call

service. Always inspect the jobsite for evidence of unmarked utilities and contact others if necessary.

Plan Your Work

Be aware of the lead time for marking in your area. This time may vary from state to state and county to county. If you don't locate utilities, you may have an accident or suffer injuries, cause service interruptions, damage the environment or experience job delays.

Dig

Most utilities mark their underground facilities using American Public Works Association (APWA) underground color codes. Verify marks before digging.

In the United States, OSHA Standard 29 CFR 1926.651 requires that the estimated location of underground utilities be determined before beginning an excavation. When actual excavation approaches an estimated utility location, the exact location of the underground installation must be determined by a safe, acceptable and dependable method. Other OSHA regulations may also apply to your jobsite.

7

Follow a Safety Program

Protect Yourself

Wear personal protective clothing and Personal Protective Equipment (PPE) issued to you or called for by job conditions.

You may need:

- Hard hat
- Safety shoes
- Safety glasses, goggles or face shield
- Heavy gloves
- Hearing protection
- Reflective clothing
- Wet weather gear
- Respirator or filter mask

Wear whatever is needed—don't take chances.



Avoid Entanglement

WARNING! Prevent death or serious injury from entanglement. **Do not wear loose clothing or accessories. Stay away from all rotating components when the engine is running.** Contact, wrapping or entanglement with rotating or moving parts could result in death or serious injury.

Follow a Safety Program

Be Alert!

Know where to get assistance. Know how to use a first aid kit and fire extinguisher/fire suppression system.

Be Aware!

Take advantage of training programs offered.

Be Careful

Human error is caused by many factors: carelessness, fatigue, overload, preoccupation, unfamiliarity of operator with the machine, drugs, and alcohol to name a few. Damage to the loader can be fixed in a short period of time, but injury, or death, has a lasting effect.

For your safety and the safety of others, encourage your fellow workers to act safely.



Never Use Drugs
or Alcohol While
Operating

For Safe Operation

You must be a qualified and authorized operator for safe operation of your machine. You must clearly understand the written instructions supplied by the manufacturer, be trained—including actual operation of the compact tool carrier—and know the safety rules and regulations for the worksite. It is a good safety practice to point out and explain safety signs and practices and ensure the crew understands the importance of following these instructions.

WARNING! Drugs and alcohol affect an operator's alertness and coordination and the operator's ability to safely operate the equipment. **Never use drugs or alcohol while operating the compact tool carrier. Never knowingly allow anyone to operate this compact tool carrier when their alertness or coordination is impaired.** An operator taking prescription or over-the-counter medication must consult a medical professional regarding any side effects of the medication that would hinder their ability to safely operate this equipment.

Follow a Safety Program

Know the Rules

Most employers have rules governing operation and maintenance of equipment. Before you start work at a new location, check with your supervisor or the safety coordinator. Ask about the rules you will be expected to obey.

The Occupational Safety and Health Administration (OSHA) enforces federal laws within the United States that apply to safe operation, application and maintenance of equipment on a worksite. It is the employer's responsibility to comply with these laws. An OSHA representative may periodically inspect a worksite to see that these laws are being followed.

There may also be local or state/provincial laws or international regulations that apply to this equipment and its use, along with specific worksite or employer rules. It is important that you know and comply with all applicable laws and rules, including those requiring operator training and certification.



Know and
Understand
Rules of
Operation

Follow a Safety Program

Some Rules You Must Work By

- Know the capacity and operating characteristics of your compact tool carrier. Do not overload it.
- Never modify or remove any part of the equipment (except for service—then make sure it is replaced).
- Keep bystanders away from the work area.
- Know the worksite before you use the compact tool carrier. Be aware of possible terrain hazards that you may encounter.
- Only use attachments that are approved by the compact tool carrier manufacturer.
- Carry the load as low as possible.
- **Never** operate the compact tool carrier on public roads.
- **Do not** allow riders.
- Make sure all attachments are lowered, set the parking brake, shut off the engine, cycle the control levers including the auxiliary hydraulic control. Remove the key before leaving the compact tool carrier.
- When transporting the compact tool carrier on a trailer, follow the manufacturer's detailed instructions for loading, tying down and unloading the compact tool carrier.

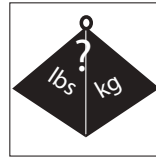

Know
Weight of
Load

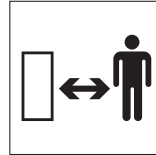

Keep
Bystanders
Away



No
Riders

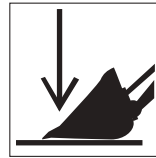

Lower
Attachments
to the Ground

11

Follow a Safety Program

Know the Equipment

Read and understand the DANGER, WARNING, CAUTION and NOTICE safety signs and other informational signs on the compact tool carrier and in the manufacturer's operator's manual. Ask your supervisor to explain any information you do not understand. Failure to obey safety instructions could result in death or serious injury.

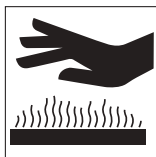
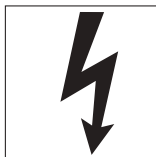

Read and
Understand All
Safety Signs

Make sure all the manufacturer's protective structures, guards, shields, screens and panels are in good repair, in place and securely fastened. Damaged, missing or weakened safety components can create a hazardous situation for you as the operator. **Never** remove or modify any safety components on your compact tool carrier.

Know the following about your compact tool carrier:

- How to operate all controls
- The functions of all gauges, lights, dials, switches
- How to operate the compact tool carrier on slopes and inclines
- Braking and steering characteristics
- Turning radius and clearances



Read and
Understand
Manuals Before
Operating

12

Prepare for Safe Operation

Check the Machine

Before you begin your workday inspect your compact tool carrier and have all systems in good operational condition.

Do not operate the machine until all problems are corrected.

- Perform daily and periodic service procedures as instructed by the equipment manufacturer.
- Check and use all available protective and safety devices, such as parking brake, safety tread and grab handles.
- Check for broken, missing or damaged guards and shields. Make any necessary repairs.
- Check tires for cuts, bulges and correct inflation, or check tracks for cuts and proper tension.
- Check all safety signs for clarity. Consult the manufacturer for replacement or clarification.
- Check all fluid levels. Fill to the required level with the proper fluid as needed.
- Keep engine compartment clean and free of debris.

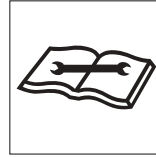

Maintain Machine



Maintain Proper Tire Pressure



Check the Radiator and Engine

13

Prepare for Safe Operation

Check the Machine (continued)

- Inspect all hoses and hose connections for wear, damage and leaks. Make all necessary repairs.
- Check the hydraulic system for leaks and damage. Repair or adjust as needed.

WARNING! Diesel fuel or hydraulic fluid under pressure can penetrate the skin or eyes and cause serious injury, blindness or death. Fluid leaks under pressure may not be visible. **Use a piece of cardboard or wood to find leaks, not your hand. Wear a face shield or safety goggles for eye protection.** If fluid is injected into the skin, it must be removed within a few hours by medical personnel familiar with this type of injury. (See page 39, **Hydraulic System Hazards.**)

- Keep the operator platform surface, if equipped, clean and free of grease, oil, dirt, snow or ice.
- Ensure all doors, safety devices, guards and covers are in place and secured properly.
- Ensure work lights are kept clean (if equipped). Check that all lights work properly.
- Ensure all tools or loose objects are removed or securely fastened while operating the compact tool carrier.



Inspect Hoses



High Pressure Fluid Can Inject into the Body

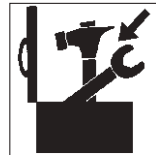

Put Away Tools

14

Prepare for Safe Operation

Know the Work Area

Before you operate the compact tool carrier, learn as much as possible about the work area. Walk around the worksite and inspect the surfaces you will travel on when using the compact tool carrier.

Locate and avoid:

- | | |
|------------------|--|
| – Holes | – Slippery surfaces |
| – Drop-offs | – Oil spills |
| – Obstacles | – Power lines and apparatus |
| – Excavations | – Gas lines or apparatus |
| – Standing water | – Other utilities |
| – Deep mud | – Any conditions which could cause collision, loss of control or tipover |
| – Wet spots | – Steep slopes |
| – Soft soil | |
| – Rough spots | |

Correct unsafe conditions. Avoid operating in problem areas that cannot be corrected.

Check for weak spots when operating on docks, ramps or floors. Clear away trash and debris. Pick up anything that could puncture a tire.

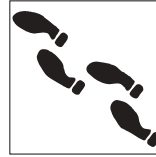

Walk
Around the
Worksite



Know
Weight Limits

WARNING! Avoid possible injury. The weight of your machine may cause the ground, dock, ramp or floor to give way causing loss of control, fall or tipover. **Know weight limits and stay clear of the edges of excavations or drop-offs.** Failure to know and observe weight limits and use caution could result in death or serious injury.

15

Prepare for Safe Operation

Know the Work Area (continued)

Plan travel routes for inside work in order to see and protect bystanders.

Plan your work. Make sure you know where you will make your pickups, lifts and turns. Before you raise a loaded bucket, know where you will dump it and always carry the load low.

Check for overhead obstructions. Check the clearances of doorways, canopies and overheads. Know exactly how much clearance you have under power and telephone cables.

Maintain minimum safe distance from power lines. If possible, have power to lines disconnected. If this is not possible, request a signal person to guide you while you work around power lines.

When working near power lines, always assume conductors are energized.

DANGER! Avoid electrocution or serious injury. **Do not allow load or any part of machine to approach or contact energized power lines or apparatus.** Death or serious injury will result from contact or inadequate clearance to energized power lines or apparatus.

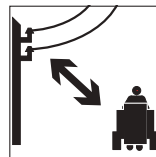

Do Not
Approach
Energized
Power Lines



811 or
1-888-258-0808

One-Call
First

WARNING! Avoid possible injury from contact with buried utilities. **Always contact your local One-Call center and any utility companies that do not subscribe to One-Call before digging.** Failure to locate existing utilities could result in death or serious injury. (See page 7, **One-Call First.**)

When excavating near underground services, expose the service by hand-digging or by using soft excavation, such as vacuum excavation when permitted by local utilities.

16

Prepare for Safe Operation

Plan Your Work

Before you operate, plan how and where you will travel, turn and pick up, lift and place loads.

Choose a smooth level route to prevent possible tipover or loss of load. If possible, avoid crossing:

- Ruts
- Ditches
- Curbs
- Exposed Railroad Tracks

Watch Out for Obstacles

Watch for obstacles. Go around rocks and stumps. Avoid crossing ditches, curbs and other exposed raised obstacles. If obstacles are unavoidable, reduce speed, raise attachment for clearance. Check for hidden or buried obstacles that could cause a collision.

Never back off a curb or step with no load or with lift arms raised. Be careful of sudden machine movement when the loader climbs or is driven off a curb or step. Use caution when traveling on difficult terrain. Keep the load as low as possible and reduce speed.



Avoid Ruts and Ditches

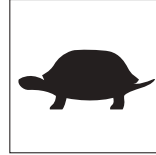

Travel Slowly

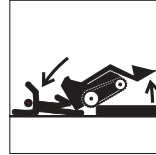

Do Not Back Off Curbs with No Load

17

Prepare for Safe Operation

Watch Out for Obstacles (continued)

Know where there are blind corner conditions on the worksite. Before turning a blind corner, stop until your presence has been acknowledged by those in your path or the path is clear.

Always maintain a safe distance between your compact tool carrier and other equipment and obstacles at the worksite.

Know the weights of all loads you may be expected to transport before attempting to lift them. Secure loose loads. Check that loads are properly banded or strapped together.

If you are placing a load in an area where visibility is a problem, use a signal person near the point where the load will be landed.

Remember:

- **Be Alert**—Know that conditions can change.
- **Use Common Sense**—Show that you are a responsible operator.
- **Be a Defensive Operator**—Prevent accidents before they happen.

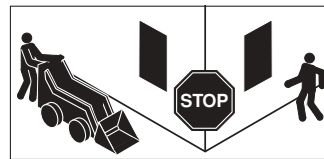

Avoid Blind Corners

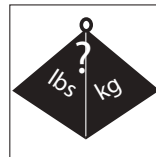

Know Weight of Load



Use a Signal Person

Start Safely

Start the Machine

Before starting the compact tool carrier and operating the machine, walk completely around the compact tool carrier and check that it is clear of personnel.

- Clean your footwear and wipe your hands before using the compact tool carrier.
- Use the handrails or handholds to mount the compact tool carrier if it is equipped with an operator platform. Never grab steering or control levers when mounting.
- Position yourself in the manufacturer’s recommended operating position. The compact tool carrier must be operated only from the operating position.

Start the compact tool carrier following the specific procedures in the manufacturer’s operator’s manual. These procedures will normally include:

- Position all controls in NEUTRAL including the auxiliary hydraulic control.
- Be sure all brakes are set.
- Familiarize yourself with the warning devices, gauges and controls.
- Warn all others in the area that you are going to start the compact tool carrier.

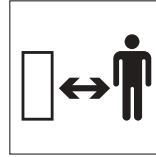

Keep Bystanders Away



Three Point Contact Entry Process



Set Brake

Start Safely

Run an Operating Check

WARNING! Avoid possible injury from loss of control. **Know and understand the control pattern and control modes before operating the compact tool carrier. Do not modify manufacturer’s control pattern.** Death or serious injury could result from loss of machine control.

WARNING! Avoid possible injury from fall, run over, entanglement, exposure to pinch points or tipover. **Never allow riders. This compact tool carrier is designed for ONE-PERSON operation only.** Death or serious injury could result from allowing riders on this machine.

Check before operating:

- All instruments, gauges and indicator lights
- Horn and backup alarms (if equipped)
- All control levers for proper operation
- Brakes for proper operation

If there is any indication that an abnormal condition exists or the controls do not respond correctly, shut down safely and correct the condition before operating.

Be sure you can control both the speed and direction before moving. Start, stop, travel and brake smoothly. Slow down for turns. Slow down for rough, slippery or soft terrain.



No Riders

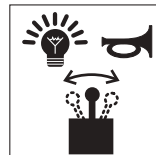

Check Instruments and Controls

Start Safely

Check Attachment and Coupler Installation

When changing buckets or installing attachments follow the manufacturer's instructions for proper maintenance and coupling. Make sure all connectors are securely fastened. Tighten all bolts, nuts and screws to torques recommended.

Check the attachment coupler and the attachment for wear and hydraulic leaks before coupling the attachment to the machine.

Check to be sure that the coupler pins or wedges are fully engaged into the attachment and that the coupler is securely engaged to the attachment both mechanically and hydraulically before operating.

WARNING! Avoid possible crushing injury. **Failure to properly secure the attachment to the machine coupler can allow the attachment to come off and could result in death or serious injury.**

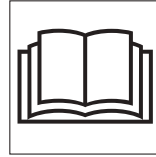

Read and Understand Manuals



Read and Understand Machine Signs



Never Lift or Swing a Load or Attachment Over Anyone

Operate Safely

Remember These Rules:



Read and Understand Manuals Before Operating



Read and Understand Machine Signs

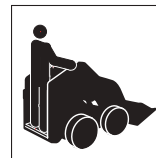

Operate Only from Operator's Position

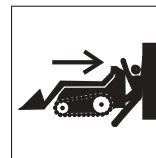

Always Look in the Direction of Travel

- Always read and understand manufacturer's manual and machine safety signs before operating.
- Always know where to get assistance in case of an emergency.
- Always check for utilities before digging.
- Always avoid distractions such as cell phones, headphones and horseplay.
- Always ensure the attachment is properly installed.

- Always operate the compact tool carrier from the operator's position. Keep your feet on the platform, if equipped, and your hands on handholds or controls. Stay away from tracks.
- Always look in the direction of travel, even when traveling in reverse.
- Always keep away from lift arms when raised. Lift arms left in the raised position **must be supported** by the approved lift arm support device(s).

Operate Safely

Remember These Rules: (continued)

- Always make sure the work area is clear of other machines and personnel. Warn others in area before starting. **Never** lift, swing or move a load or attachment over anyone.
- Always stay in control of your machine and load. Do not jerk controls. Travel and turn slowly and smoothly. Travel and turn with lift arms down. Carry load low. Keep load level while lifting. Keep heavy end uphill. Never drive over drop-offs.
- **Never permit riders.** Never use a bucket, forks or attachment as an elevated work platform.
- Never modify your equipment. Use only attachments approved by the manufacturer.
- Never exceed the rated operating capacity of your machine. Be aware of changed weight distribution when operating with heavy attachments.
- Never operate your compact tool carrier in an atmosphere with explosive dust, explosive gas or where exhaust can contact flammable material.

- Never leave the compact tool carrier unattended without lowering the lift arms, placing the attachment flat on the ground and safely shutting down the machine and attachment. (See page 32, **Safe Shut Down.**)



Do Not Lift or Swing a Load or Attachment Over Anyone

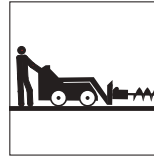

Carry Load Low

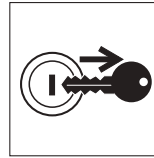

Shut Down Unattended Equipment

Operate Safely

Lift the Load Safely

Know the rated operating capacity of your compact tool carrier. Refer to the compact tool carrier capacity chart (if provided) to determine the operating range for safe lifting, transporting and placing of the load.

You, as the operator, should know, or be able to estimate, the weight and load center of the load you will be lifting. If you are unsure of the weight and load center of the load, check with your supervisor or with the material supplier.

Before picking up a load:

- Note the condition of the terrain. Adjust the travel speed and reduce the amount of the load if the conditions suggest an unstable path.
- Avoid lifting double-stacked loads—they are difficult to control. Separate the load into two or more loads.
- Make sure the load is clear of obstructions especially when handling long, tall or wide loads.
- Be sure the load center of gravity is in the center of the attachment. Approach the load slowly and squarely.

- Adjust spacing of forks to engage the pallet or load at maximum width. **Never use just one fork to lift a load.**

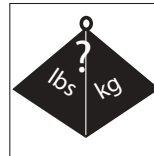

Know Weight of Load

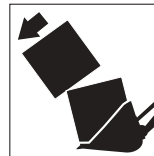

Avoid Double-Stacked Loads

Operate Safely

Transporting Loads

After engaging the load, tilt the load back to position it for travel. Keep the load level when lifting.

Lift the load only high enough to clear obstacles that may be in the path of the compact tool carrier. Carry the load as close to the machine as possible to:

- Provide better stability of the compact tool carrier.
- Reduce the chance of spilling the load while traveling over rough terrain.
- Allow for better visibility over the load.
- Help to maintain control of steering.
- Prevent pitching the load when traveling over a bump or curb with a tracked machine. Excessive speed may cause the machine to become unstable.

WARNING! Avoid possible injury from loss of control or tipover. **Do not travel or turn with the lift arms raised.** Loss of control or tipover could cause death or serious injury.



Carry Load Low



Travel Slowly Over Rough Terrain



Do Not Travel with Lift Arms Raised

Operate Safely

Transporting Loads (continued)

Remember that smooth, controlled actions on your part are important for safe transport. To avoid tipover or toppling a load, apply these actions at all times:

- Keep the load as low as possible.
- Do not lift load while traveling.
- Do not jerk the lift or travel controls.
- Accelerate and decelerate slowly.
- Avoid sudden starts and stops.
- Travel with **caution** and at the **slowest** possible speed.
- Come to a gradual, complete stop before reversing direction. Avoid obstacles and rough terrain.
- Travel up and down slopes, never across them.
- Avoid steep slopes.
- Avoid sharp turns.

Ensure there is adequate clearance in all directions when turning with a load to avoid injury to personnel or damage to nearby objects.



Operate Controls Smoothly

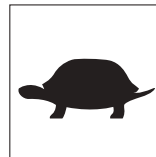

Travel Slowly

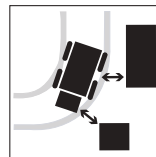

Check Clearances Before Travel

Operate Safely

Traveling on Slopes and Inclines

You must exercise additional care if operating on slopes or inclines. Driving on slopes and inclines can be dangerous and result in a tipover or loss of load.

WARNING! Do not travel on slopes or inclines with lift arms elevated. Loss of load or tipover could cause death or serious injury.

To avoid injury or damage follow these rules:

- Avoid steep slopes and unstable surfaces. If you must drive on a slope, keep the load low and proceed with extreme caution. **Do not drive across** excessively steep slopes under any circumstances. Travel straight up and down the slope.
- Avoid turning on inclines and slopes.
- Ascend or descend inclines and slopes with the “heavy end” of the compact tool carrier on the **uphill** side of the slope.

Normally, when **not carrying a load**, the **rear** of the compact tool carrier is the “heavy end.” Normally, **when carrying a load**, the **front** of the compact tool carrier becomes the “heavy end.”



Do Not Travel with Lift Arms Raised



Traveling with No Load, Attachment Downhill



Traveling with a Load, Attachment Uphill

27

Operate Safely

Lifting and Placing/Emptying the Load

When the load has been transported to the location where it is to be placed, remember:

- The chosen landing location should be level, both front to back and side to side.
- While lifting and lowering the load, always make sure the path of the load is clear of obstacles.
- Approach the landing location slowly with the load as low as possible.
- Drive as close as possible to the landing location.
- Avoid a sudden stop.
- Place the compact tool carrier in NEUTRAL.
- Lift the load slowly and smoothly.
- After raising the load drive forward slowly to position where the load will be placed or emptied.
- Place or empty the load.
- Drive backwards slowly to clear the placed or emptied load.
- Lower the lift arms.

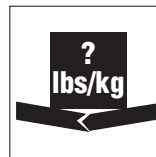

Know Weight Limits

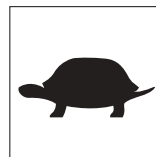

Travel Slowly

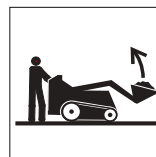

Lift Loads Slowly and Smoothly

28

Operate Safely

- Follow these important practices when lifting loads:
- The load must be centered when lifting. The likelihood for the compact tool carrier to tip is greatly increased if the load is not centered before lifting.
 - Use extreme care when lifting items with an attachment. Keep the load level when raising the lift arms. Excessive tilt-back can cause the load to fall out of the bucket and back toward the operator.
 - Raise load slowly at an even rate and be ready to lower the load quickly if the machine gets in an unstable situation.



Operate Controls Smoothly

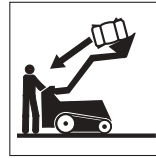

High Loads May Shift

Operate Safely

Loose or Irregular Loads

Use extra care when carrying drums, cylinders, reels or other round objects. These and other loose, irregular-shaped loads are more likely to fall if not handled properly.

- Keep the attachment tilted back to hold the load.
- Secure loose loads to the attachment.

Watch clearances carefully when handling loads that are long, tall or wide. Load end-swing can be deceiving and could cause injury to personnel or damage to objects nearby.

Where the load will obstruct your vision, it is recommended that the compact tool carrier be operated in reverse. Look rearward in the direction of travel. Travel at a slower speed and have someone direct you.

Traveling with Heavy Attachments

Be aware that heavy attachments such as augers, trenchers, breakers, snowblowers, etc. change the weight distribution of your machine. Use extra care when loading/unloading, traveling and turning.

Some attachments require that lift arms and therefore the mass of the attachment be raised during operation. Return the attachment to the travel position, keeping the lift arms lowered and the mass of the attachment low while traveling.



Secure Loose Loads

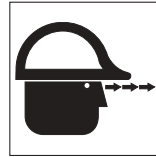

Look Where You Are Traveling

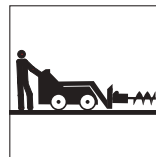

Travel with Attachment Low

Operate Safely

Watch Out For Hazardous Working Conditions

Be alert for hazards. Know where you are at all times. Watch for branches, cables and doorways. Watch for unstable soil.

Use caution when working along docks, runways, banks and slopes. Keep away from the edge of drop-offs or gullies.

Use caution when working beneath an overhang or next to a high bank. Be careful not to undercut a high bank or overhang causing material to fall on your machine or a collapse of the bank.

WARNING! Extreme caution should be used when working along the top of banks or slopes. Watch for loose areas or overhangs. Keep away from the edge. The edges could collapse or a slide could occur causing serious injury or death.

Stay alert! Cave-ins are hazardous.

Use caution in backfilling or other activities near an excavation. Do not get too close to the wall. The combined weight of your machine and the load could cause the wall to collapse.

If necessary when working under hazardous conditions, use a second person to warn of dangers. Make certain they do not get too close to the loader.



Never Undercut a High Bank

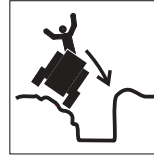

Use Care Near Excavations



Use a Signal Person

31

Shut Down Safely

Safe Shut Down

Properly shutting down a compact tool carrier can help prevent accidents from occurring when the compact tool carrier is left unattended. Shut down the compact tool carrier following the specific procedures in the manufacturer's operator's manual. These procedures will normally include:

- Come to a full stop on a level surface.
- Set the parking brake.
- Lower the lift arms and place the attachment flat on the ground.
- Place the controls in NEUTRAL (or PARK) including the auxiliary hydraulic control.
- Reduce engine speed.
- Shut off the engine.
- Cycle all hydraulic controls to relieve trapped pressure in the system.
- Remove the ignition key.

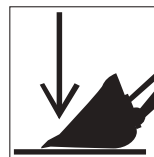

Lower Attachments Before Leaving the Machine

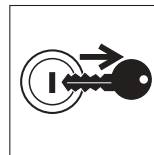

Shut Engine Off, Remove Key

32

Load and Unload Your Machine

Loading and Unloading the Compact Tool Carrier

When transporting the compact tool carrier, follow the manufacturer's recommendations for loading and unloading.

Precautions

- Keep bystanders out of the loading and unloading area.
- Load and unload on a level surface.
- Block transport vehicle so it does not move.
- Use ramps of adequate size and strength, low angle and proper height.
- Block or support the rear of trailer.
- Keep trailer bed and ramps free of clay, oil, ice, snow and other materials that can become slippery.
- Keep heavy end uphill. (A heavy attachment may result in the need to travel up ramps in forward position.)
- Chain and block the compact tool carrier securely for transport. Use tie-down points as marked on the compact tool carrier by the manufacturer. Follow the manufacturer's instructions in the operator's manual for tie-down procedures.

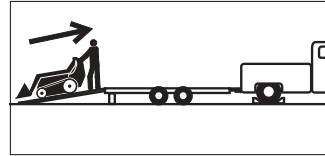

Load and Unload Safely

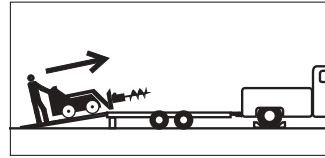

Keep Heavy End Uphill

33

Perform Maintenance Safely

Maintain Your Equipment



Maintain Equipment

Be sure to maintain your equipment according to manufacturer's instructions. Regularly check the operation of the protective and safety devices.

Do not perform any work on a compact tool carrier unless you are authorized and qualified to do so.

If you have been authorized to do maintenance, **read the operator's and service manuals.** Study the instructions; check the lubrication charts; examine all the instruction messages on the compact tool carrier. Maintenance can be dangerous unless performed properly. Be sure you have the necessary skill, information, correct tools and equipment to do the job correctly.



IMPORTANT! Do not modify equipment or add components not approved by the manufacturer. Use parts, lubricants and service techniques recommended by the manufacturer.

Prepare Yourself

Wear personal protective clothing and Personal Protective Equipment (PPE) issued to you or called for by job conditions.

You may need:

- Hard hat
- Safety shoes
- Safety glasses, goggles or face shield
- Apron and gloves
- Hearing protection
- Welding helmet or goggles
- Respirator or filter mask

Wear whatever is needed—don't take chances.

Keep hands—and clothing—away from all moving parts. Don't tempt fate with dangling ties, loose sleeves, rings, watches, or long hair.

34

Perform Maintenance Safely

WARNING! Prevent death or serious injury from entanglement. **Do not wear loose clothing or accessories. Stay away from all rotating components when the engine is running.** Contact, wrapping or entanglement with rotating or moving parts could result in death or serious injury.

Wear a rubber apron and rubber gloves when working with corrosives. Wear gloves and safety shoes when handling wooden blocks or sharp-edged metal.

Always use safety glasses, goggles or a face shield. They provide eye protection from fluids under pressure, while grinding and servicing batteries. Protection is also needed from flying debris, liquids and loose material produced by equipment, tools and pressurized air/water.

Wear a face shield when you disassemble spring-loaded components or work with battery acids. Wear a welding helmet or goggles with a shaded filter when you weld or cut with a torch.

Do not sand, grind, flame-cut, braze or weld without a NIOSH-approved respirator or appropriate ventilation. If welding is required on this machine, refer to the

manufacturer's manuals or consult your equipment dealer for proper procedures.

Keep pockets free of all objects that could fall out—and drop into machinery.

Handle tools and heavy parts sensibly—with regard for yourself and other persons. Lower items—don't drop them.

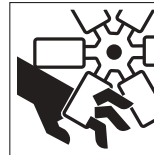

Avoid Rotating Parts



Avoid Pinch Points

35

Perform Maintenance Safely

Prepare the Work Area

- Position the compact tool carrier in a level area out of the way of other working equipment.
- Make sure there is adequate light, ventilation and clearance.
- Remove oil, grease or water to eliminate any slippery surfaces.
- Clean around the area to be serviced to minimize contamination.

Prepare the Machine

- Attach a “DO NOT OPERATE” warning tag to the control levers and remove the ignition key if the compact tool carrier should not be started.
- Install the approved lift arm support device(s) when working under or near raised lift arms. Remove attachment before raising lift arms and before installing support device(s).

WARNING! Disconnecting or loosening any hydraulic tubeline, hose, fitting, component or a part failure can cause unsupported lift arms to drop. **Do not go under lift arms when raised unless supported by an approved lift arm support device(s).** Death or serious crushing injury could result from falling lift arms.

- Remove only guards or covers that provide access to the area being serviced. Replace all guards and covers when work is complete.



Clean Slippery Surfaces

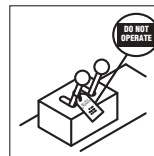

Use Warning Tags

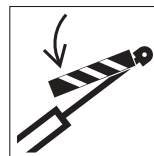

Use Approved Lift Arm Support Device

36

Perform Maintenance Safely

Use Proper Ventilation

If it is necessary to run an engine in an enclosed area, remove the exhaust fumes from the area with an exhaust pipe extension. If you do not have an exhaust pipe extension, make sure you open the doors and get outside air into the area.

WARNING! Prevent possible injury. **Never work on machinery with the engine running unless instructed by the manufacturer's manuals for specific service.**

WARNING! **Never operate any type of engine without proper ventilation—EXHAUST FUMES CAN KILL.**

Use Jacks and Hoists Carefully

If you must work beneath raised equipment, always use wood (**not concrete**) blocks, jack-stands or other rigid and stable supports. When using jacks or hoists always be sure they are adequately supported.

WARNING! Prevent possible crushing injury. **Never use concrete blocks for supports.** They can collapse under even light loads.

Make sure the hoists or jacks you use are in good repair. Never use jacks with cracked, bent, or twisted parts. Never use frayed, twisted or pinched cables. Never use bent or distorted hooks.

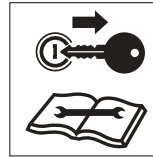

Remove
Key and Read
Maintenance
Manual

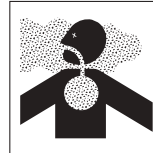

Ventilate
Work Area



Use Proper
Support for Raised
Equipment

37

Perform Maintenance Safely

Common Maintenance Safety Practices

Fuel Hazards



IMPORTANT! Always use approved fuel containers and/or dispensing equipment.

Fuels are flammable, so observe these practices to reduce the possibility of a serious accident.

- Shut off engine and ignition during refueling.
- Always ground the fuel nozzle against the filler neck to avoid sparks.
- Keep sparks and open flames away from fuel.
- Do not smoke while refueling or when handling fuel containers.
- Do not cut or weld on or near fuel lines, tanks or containers.
- Do not overfill the tank or spill fuel. Clean up spilled fuel immediately.

Engine Coolant Hazards

Liquid cooling systems build up pressure as the engine gets hot, so **use extreme caution before** removing the radiator cap.

Be sure to:

- Stop the engine and wait for the system to cool.
- Wear protective clothing and safety glasses.
- Turn the radiator cap slowly to the first stop to allow the pressure to escape before removing the cap completely.



No Smoking
and No Open
Flames



Remove
Radiator Cap
Slowly

Perform Maintenance Safely

Hydraulic System Hazards

The hydraulic system is under pressure whenever the engine is running and may hold pressure even after the engine is shut off. Cycle all hydraulic controls including the auxiliary hydraulic control after the engine is shut down. Relieve trapped pressure in the lines after the attachments are shut down and resting on the ground.

During inspection of the hydraulic system:

- Wait for fluid to cool before disconnecting the lines. Hot hydraulic fluid can cause SEVERE BURNS.
- **Do not** use your hand to check for leaks. Instead, use a piece of cardboard or paper to search for leaks.
- Wear appropriate eye protection. Hydraulic fluid can cause permanent eye injury.

WARNING! Diesel fuel or hydraulic fluid under pressure can penetrate the skin or eyes and cause serious injury, blindness or death. Fluid leaks under pressure may not be visible. **Use a piece of cardboard or wood to find leaks, not your hand. Wear a face shield or safety goggles for eye protection.** If fluid is injected into the skin, it must be removed within a few hours by medical personnel familiar with this type of injury.

When venting or filling the hydraulic system, loosen the filler cap slowly and remove it gradually.

Never reset any relief valve in the hydraulic system to a pressure higher than recommended by the manufacturer.

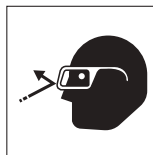

Wear
Eye Protection



High Pressure
Fluid Can Inject
Into the Body

39

Perform Maintenance Safely

Electrical System Hazards

Before working on the electrical system, disconnect the battery cable(s).

- Remove the battery negative (-) cable(s) first.
- When reconnecting the battery, connect the battery negative (-) cable(s) last.

The liquid in batteries is called “electrolyte.” Electrolyte contains sulfuric acid, which is a POISON and can cause SEVERE CHEMICAL BURNS.

Avoid Injury

- Wear a face shield to prevent contact with your eyes.
- Wear chemical-resistant gloves and clothing to keep this electrolyte off your skin and regular clothing.

WARNING! Electrolyte will damage eyes or skin on contact. **Always wear a face shield to avoid electrolyte in eyes.** If electrolyte contacts eyes, flush immediately with clean water and get medical attention. **Wear rubber gloves and protective clothing to keep electrolyte off skin.** If electrolyte contacts exposed skin or clothing, wash off immediately with clean water.

If electrolyte is ingested, seek MEDICAL ATTENTION IMMEDIATELY. NEVER give fluids that would induce vomiting.

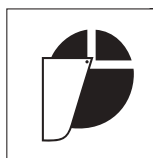

Wear
Face Protection

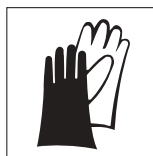

Wear
Protective
Clothing

Perform Maintenance Safely

Avoid Explosion

WARNING! Avoid possible serious injury from explosion. Lead-acid batteries produce extremely explosive gases especially when being charged. **Keep arcs, sparks, flames and lighted tobacco away.**

- Do not smoke near batteries.
- Keep arcs, sparks and open flames away from batteries.
- Provide adequate ventilation.

Never check the battery by placing a metal object across the battery posts — the resulting spark could cause an explosion.

WARNING! Avoid possible serious injury from battery explosion. **Do not charge a battery or boost start the engine if the battery is frozen.** Warm to 60°F (15.5°C) or the battery may explode and could cause serious injury.

Safety rules during battery boost starting:

- Follow the instructions for proper “battery boost starting” as specified in the manufacturer’s manual.
- Be sure the vehicles are not touching.

- Observe the polarity of the batteries and connections.
- Make the final cable connection to the engine or the furthest ground point away from the battery. Never make the final connection at the starter or dead battery—sparks may ignite the explosive gases present at the battery.
- When disconnecting cables after jump starting, remove the cables in reverse order of connection (e.g., final connection first).

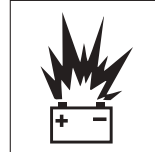

**Avoid Sparks
and Open Flames
Near Batteries**

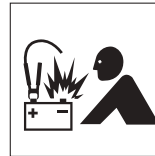

**For
Boost Starting
Observe Polarity
and Make Final
Connection at
Ground Point**

41

Perform Maintenance Safely

Tire, Wheel and Track Maintenance

Check your tires and wheels or tracks daily because the stability of the compact tool carrier can be dramatically affected by tire pressure or damage to tires, wheels or tracks.

Check tires for:

- Correct pressure.
- Cuts and bulges.
- Nails or other punctures.
- Uneven or excessive wear.
- Condition of valve stems and caps.

Check wheels for:

- Damage to the rims.
- Missing or loose lug nuts or bolts.
- Misalignment.

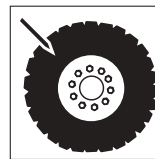

**Check Tires
and Wheels for
Damage**



**Maintain
Proper Tire
Pressure**

42

Perform Maintenance Safely

WARNING! Explosive separation of a tire and/or rim parts can cause serious injury or death. **Always follow the manufacturer's recommendations or see your tire supplier.**

Do not inflate the tires above the recommended pressure. Be sure to replace tire ballast if equipped. See manufacturer's specifications for ballast requirements.

Keep wheel lug nuts tightened to manufacturer's recommendations.

A rise in tire pressure during operation is normal, and should NOT be reduced.

When adding air to a tire, do so from a distance. Use a long hose with self-attaching chuck. Always stand behind tread when adjusting tire pressure.

Do not inflate tires with flammable gases or from systems using an alcohol injector.

Never cut or weld on a wheel with an inflated tire mounted on it. This could cause explosive decompression.

WARNING! Explosive separation of a tire and/or rim parts can cause serious injury or death. **Always use a safety cage or cable restraints when inflating a repaired tire.** Inflate the tire from a distance, using a long hose with self-attaching chuck. Stand behind the tread; keep the area to the side of the tire clear of other people.

All tire service should be performed by a qualified tire service center or by an authorized service person who has been properly trained in the procedures and use of safety equipment designed for tire servicing.

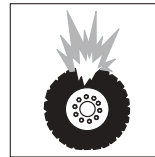

43

Perform Maintenance Safely

Tire, Wheel and Track Maintenance (continued)

WARNING! The types of rims and tires usually found on this equipment require special care when servicing to prevent death or serious injury.

Important factors to remember:

- **Never** overinflate a tire—it could explode.
- Punctures that could have allowed the ballast in a tire to leak out must be repaired and the tire refilled with ballast (if required) before the compact tool carrier is put back into operation.
- **Never** reinflate a tire that has been run flat or seriously underinflated without removing the tire from the wheel. Have the tire and rim closely inspected for damage before remounting.
- Clean the area around all wheel lug nuts or bolts and periodically check the torque per the manufacturer's specifications until the torque value stabilizes, then check at regularly scheduled intervals.
- **Never** weld on a wheel or rim.
- Check that the tire size and rim are correctly matched.

- When replacing the tires, ensure the tires are of the appropriate rating specified by the manufacturer.

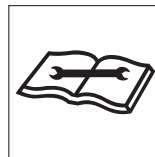

Perform Maintenance Safely

Check tracks, rollers and idlers for:

- Damaged or worn tracks.
- Correct tension according to manufacturer's instructions.
- Proper lubrication – track rollers and idlers. Refer to the manufacturer's manuals.

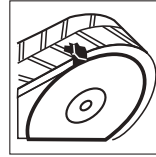

Check for
Track Damage

Track Adjustment

Track tension is important for good performance, reducing excessive track wear and preventing the tracks from coming off. Track and roller wear varies with the working conditions and soil conditions. Special tools and procedures may be needed to check or adjust track tension. Removing and installing tracks also requires following proper servicing procedures.

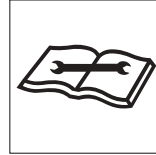

Follow
Maintenance
Instructions

WARNING! Track tensioning systems have compressed springs or pressurized fluid (oil or grease). Improperly releasing track tension forces can cause serious injury or death. **Always follow the manufacturer's warnings and instructions for track adjustment and other maintenance and servicing procedures.**

45

Perform Maintenance Safely

Complete Service and Repairs Before Machine is Released

Tighten all bolts, fittings, and connections to torques specified by the manufacturer.

Install all guards, covers, and shields after servicing. Replace or repair any damaged ones. Refill and recharge pressure systems only with manufacturer approved or recommended fluids.

Start the engine and check for leaks. (See page 39, **Hydraulic System Hazards.**) Operate all controls to make sure the loader is functioning properly. Test the loader if necessary. After testing, shut down and check the work you performed. Are there any missing cotter pins, washers, locknuts, etc.? Recheck all fluid levels before releasing the loader for operation.

All parts should be inspected during repair and replaced if worn, cracked or damaged. Excessively worn or damaged parts can fail and cause injury or death.

Replace any damaged or illegible machine signs.



Verify
Service Work
When
Completed

46

Final Word to the User

You have just finished reading the AEM Compact Tool Carrier Safety Manual. It is impossible for this manual to cover every safety situation that you may encounter on a daily basis. Your knowledge of these safety precautions and your application to the basic rules

of safety will help to build good judgment in all situations. Our objective is to help you develop, establish and maintain good safety habits to make operating a Compact Tool Carrier easier and safer for you.



e-mail safetymaterials@aem.org
www.aem.org

This manual is one in a series on the safe operation of machinery, published by AEM.



To order AEM safety materials
visit www.safetymaterials.org.



Index

A	
Abbreviations	11
Air cleaner	
servicing	90
Attachments	
information.....	18
installation	18, 57
removal.....	18, 59
safety guidelines.....	18
testing the system	59
B	
Battery	111
charge indicator light	45
maintaining	98
safety.....	98
Brakes	
hydraulic brake	55
using.....	55
Break-in period	36
Bucket	
attachment system test	59
dumping.....	62
filling	61
float.....	55
C	
Checking for leaks	78
Checklist	
operation	38
parking.....	38
start-up	37
Cleaning	20
air cleaner.....	90
machine.....	84
Cold weather	
operation in.....	42
Connecting hydraulic hoses	60
Control interlock system	
testing.....	77
D	
Demolition	16, 35
Dust precaution	16
E	
Electrical safety	20
Emission control system	
background information	115
information and warranty—diesel	115
limited defect warranty.....	116
Engine	
break-in.....	36
checking and adding coolant.....	75
checking the oil.....	80
jump-starting.....	100
oil pressure warning light.....	46
oil viscosity	74
safety	21
serial number.....	9
starting.....	40
stopping	42
warning lights (Tier IV).....	103
Excavation	16, 35
F	
Float controls	55
Fuel	
biodiesel	63
diesel	63
recommended.....	62
refueling the machine	64
H	
Hot temperatures, operation in	43
Hydraulic coupler	
attachment installation and removal	18
Hydraulics	
auxiliary connections	60
checking the oil level	76
connecting hoses.....	60
disconnecting hoses	61
overview	60
safety	21, 35
I	
Instrument display	
indicator lights (Tier IV).....	45
symbols and functions	47
J	
Jobsite	15
Jump-starting.....	100

L

Labels
 replacing 19
 Leveling the ground using the bucket float 55
 Lift arm
 float function 55
 manual override 64
 using 53
 Long-term storage 107
 Lubrication plan 73

M

Machine
 before operation 17
 break-in 36
 cleaning 20, 84
 disposal and decommissioning 108
 loading 32
 Number 8
 operation in extreme temperatures 42
 operation on slopes 56
 overview 23
 parking 66
 reference information 9
 serial number 9
 towing 34
 transportation 32
 tying down 33
 unloading 33
 Maintenance 67
 adjusting track tension 93
 battery 98
 checking track tension 93
 general notes 19
 Manual coupler
 mounting an attachment 57
 removing an attachment 59
 testing the attachment system 58
 using 57
 Material disposal 21

O

Operation checklists 37
 Operator
 presence system 18
 training 14
 Overhead electric lines 16

P

Parts
 replacing 19

Performing maintenance and repairs 67
 PPE 17
 Preparing for maintenance work 67
 Preparing transport vehicles 32

R

Risk zone 17, 35
 Running the engine 21

S

Safety
 after use 36
 at the jobsite 15
 battery 98
 before machine operation 17
 dust precaution 16
 electrical energy 20
 hydraulics 21, 35
 machine operation 17
 operating the machine 14
 operator training 14
 overhead electric lines 16
 PPE 17
 residual risks 13
 service 19
 service safety 19
 service training 19
 signal words and symbols 14
 starting and stopping 36
 when using engines 21
 Safety guidelines
 for attachments 18
 when using internal combustion engines 21
 Serial number
 engine 9
 machine 9
 Special hazards 20
 Specifications
 engine coolant 75
 fuel 62
 tightening torques 113
 track tension 93
 Starting and stopping 36
 Storage 36

T

Testing
 attachment system 59
 control interlock system 39
 Instrument display 44
 Tightening torques 113

Towing the machine	34
Tracks	
checking and adjusting tension	92
Transportation	32
Traveling	
surface conditions	56
with a load	56
without a load	56

U

Usage	
intended use	12
unintended use	12

W

Warm-up phase	41
---------------------	----

Wacker Neuson America Corporation
N92W15000 Anthony Ave
USA-53051 Menomonee Falls, WI

Tel.: +01 262 255-0500
EMail: info@wackerneuson.com
www.wackerneuson.us

Material Number: 5100064108
Language: [en-US]